

Workshop manual

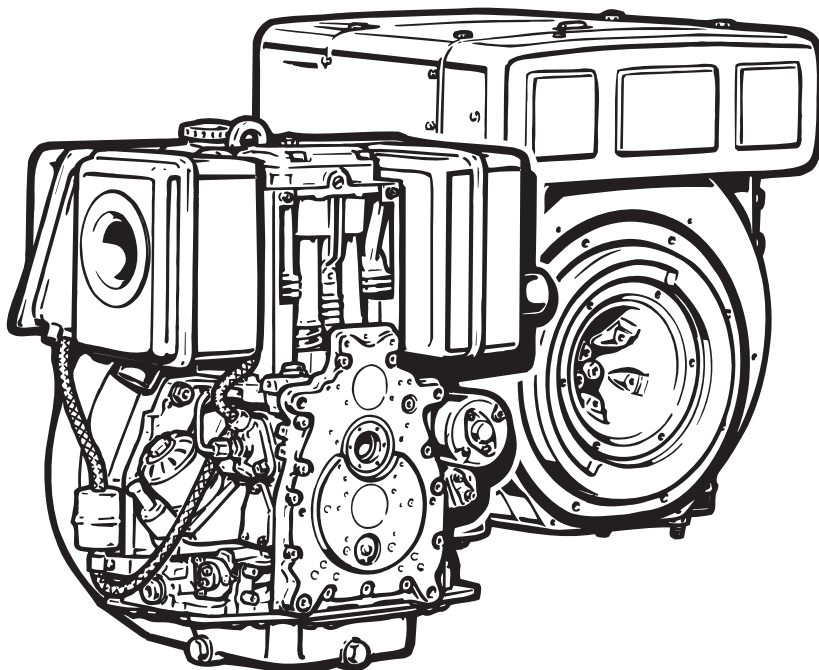

1 D . .

438 202 01 - Printed in Germany

Contents

Foreword

1. General

Engine illustrations
Technical data
Type plate data
Lubrication oil circuit
Special tools and
workshop equipments
Jointing material / Sealing and
bonding agents

2. Additional equipments

A 01.00 Fuel
A 01.10 Fuel tank
A 01.40 Fuel feed pumps
A 02:00 Combustion air
A 02.10 Oil bath air filters
A 02.11 Dry type air filters
A 02.13 Service indicators;
vacuum gauges
A 02.20 Pre-cleaners; cyclons
A 03.00 Exhausts
A 03.12 Exhaust-silencers,
Protection guard
A 04.00 Start mechanical
A 04.10 Starting handles
without supports
A 04.11 Starting handle supports
A 04.12 Cranking claws
A 04.30 Rope starts
A 05.00 Start electrical
A 05.20 Starter motors
A 05.40 Alternator / Magnet segments
A 05.41 Alternator / Coils
A 05.80 Ring gears
A 07.00 Lubrication oil
A 07.20 Lub.-oil filters, strainers
A 07.30 Oil sumps
A 09.00 Speed controls
A 09.60 Low idle speed stabilization
A 11.00 Remote engine controls
A 11.10 Stop devices
A 11.30 Auto. Shut-off device
**A 15.00 Housings, flanges,
adaptors**
A 15.20 Adaptor housings

Contents

3. Basic engine

M–Disassembly cross reference scheme

M 01.00 Crankcase

M 01.10 Crankcase, nozzle
and bearings

M 01.11 Plugs

M 01.20 Crankshaft-thrustplate
and cam followers

M 01.30 Oil sump and suction sieve

M 01.31 Oil sump 1 D 50

M 01.40 Base plate and
oil pressure relief valve

M 01.50 Cyl.-head screw sealants

M 02.00 Crankshaft

M 02.10 Wear and grinding dimensions

M 02.20 Crankshaft gearwheel and
stubshafts

M 02.30 Crankshaft / Wear sleeve

M 03.00 Bearing flange

M 03.10 Bearing flange 1D 90 V/W

M 04.00 Camshaft and balancer unit

M 05.00 Piston with connecting rod

M 05.10 Piston and piston rings

M 05.20 Connecting rod

M 06.00 Cylinder

M 07.00 Cylinder head

M 07.10 Rockers and decompression
device

M 07.20 Bumping clearance

M 07.30 Cyl.-head and oil supply pipe

M 07.40 Valves, valve guides and
valve seats

M 08.00 Cover for cylinder head

M 09.00 Pushrods / Protection tubes

M 10.00 Oil pump / Governor

M 11.00 Timing cover

M 12.00 Extra fuel device

M 14.00 Fuel-injection equipment

M 14.10 Fuel pressure pipe

M 14.20 Injector

M 14.30 Injection pump

M 14.40 Roller tappet

M 17.00 Flywheel

M 26.00 Cowling / Air duct

M 31.00 Breather system

M 32.00 Speed control

M 35.00 Capsule

4. Data sheets

Injection equipment adjustment data

Governor equipment

General adjustment and testing data

Screw tightening torques

Designations in circuit diagrams

HATZ wiring designations

Electrical circuit diagrams

Circuit diagram for measuring
currents and voltages

Generator output characteristic

Troubleshooting – electrical system

Foreword

This Workshop Manual covers the latest technical developments according to month/year indicated on each page. It has been written in such a way, that it contains all dismantling and assembly instructions in accordance with the table of contents, including all required data etc., so as to permit a trained mechanic to carry out correct and professional repairs.

We have not included information such as cleaning parts, replacing of "O" Rings, gaskets, oil seals etc. since it is assumed, of course, that the mechanic will be aware of the necessity of carrying out such work.

Use only the tools prescribed or absolutely identical tools when carrying out work of whatever nature.

It has been assumed that a standard set of workshop tools is available.

Please refer to the instruction book for maintenance work, operating materials and trouble shooting information.

Use only GENUINE HATZ PARTS for repairs!
Only these parts guarantee perfect dimensional accuracy and quality.

For the rest, please observe the general legal regulations and the regulations of the responsible professional associations.

Discrepancies may occur between the described features and actual features owing to special equipment, and it has not been possible to allow for such discrepancies either in the Workshop Manual or in the spare parts list.

Should you have any difficulties, please contact your nearest HATZ-Service agent.



1. General

Engine illustrations

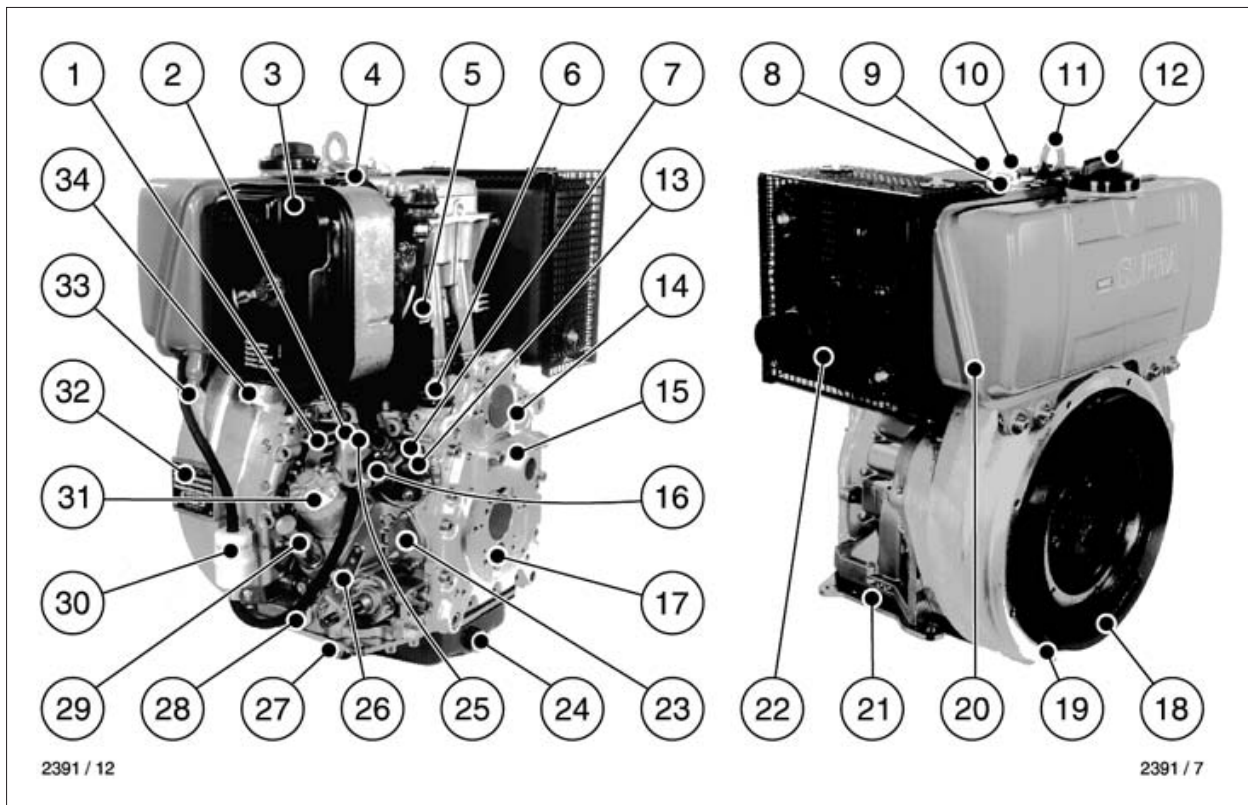

Engine 1D30, 1D31, 1D40, 1D41, 1D50, 1D60, 1D80, 1D81, 1D90 S/Z/T/U

- | | |
|------------------------------------------|-----------------------------------|
| 1 Cooling air inlet | 18 Flywheel |
| 2 Oil pressure switch | 19 Engine flange |
| 3 Dry type air cleaner | 20 Fuel tank |
| 4 Decompression lever | 21 Engine base plate |
| 5 Cooling air outlet | 22 Exhaust silencer |
| 6 Extra fuel device | 23 Fuel feed pump (mounting pos.) |
| 7 Injection pump | 24 Oil drain plug, governor side |
| 8 Injector | 25 Injection pump bleeder valve |
| 9 Cylinder head cover | 26 Speed control lever |
| 10 Cold start-oil priming device | 27 Oil drain plug, control side |
| 11 Lifting bracket, max. 120 kg / 265 lb | 28 Oil pressure relief valve |
| 12 Fuel filler cap | 29 Oil filling hole and dipstick |
| 13 Stop lever | 30 Fuel filter |
| 14 Timing cover | 31 Oil filter (optional) |
| 15 Guiding shell for starting handle | 32 Type plate |
| 16 Fuel pressure pipe | 33 Fuel tank drain plug |
| 17 Governor | 34 Combustion air intake |

Engine illustrations

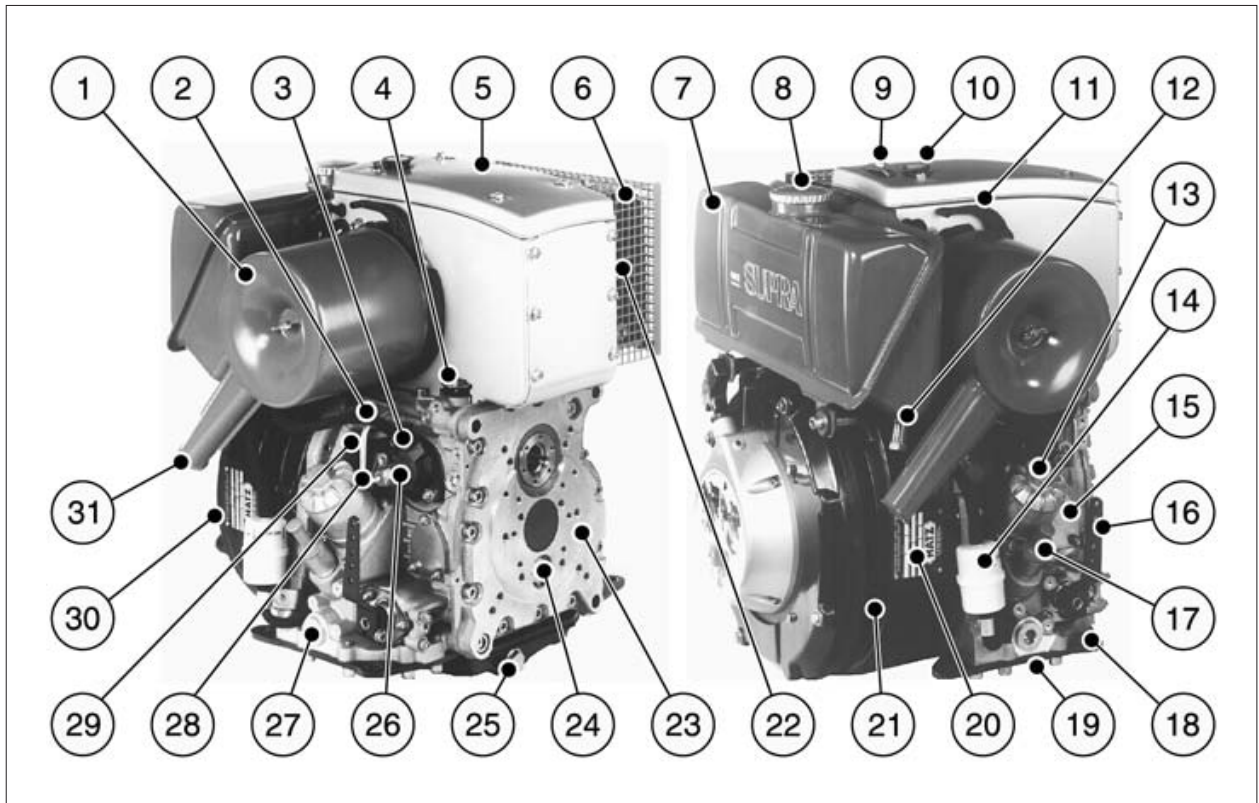

Noise-optimized version
Engine A1D35, A1D40, A1D41 S/Z/T/U

- | | |
|-----------------------------------------|----------------------------------|
| 1 Air filter | 16 Speed control lever |
| 2 Oil pressure switch | 17 Oil filling hole and dipstick |
| 3 Injection pump bleeder valve | 18 Engine base plate |
| 4 Extra fuel device | 19 Oil drain plug, control side |
| 5 Air cowling cover | 20 Type plate |
| 6 Exhaust silencer | 21 Engine flange |
| 7 Fuel tank | 22 Cooling air outlet |
| 8 Fuel filler cap | 23 Timing cover |
| 9 Lifting bracket, max. 120 kg / 265 lb | 24 Governor |
| 10 Cold start-oil priming device | 25 Oil drain plug, governor side |
| 11 Decompression lever | 26 Injection pump |
| 12 Fuel tank drain plug | 27 Oil pressure relief valve |
| 13 Oil filter (optional) | 28 Fuel pressure pipe |
| 14 Fuel filter | 29 Cooling air inlet |
| 15 Fuel feed pump (mounting pos.) | 30 Flywheel |
| | 31 Combustion air intake |

Engine illustrations

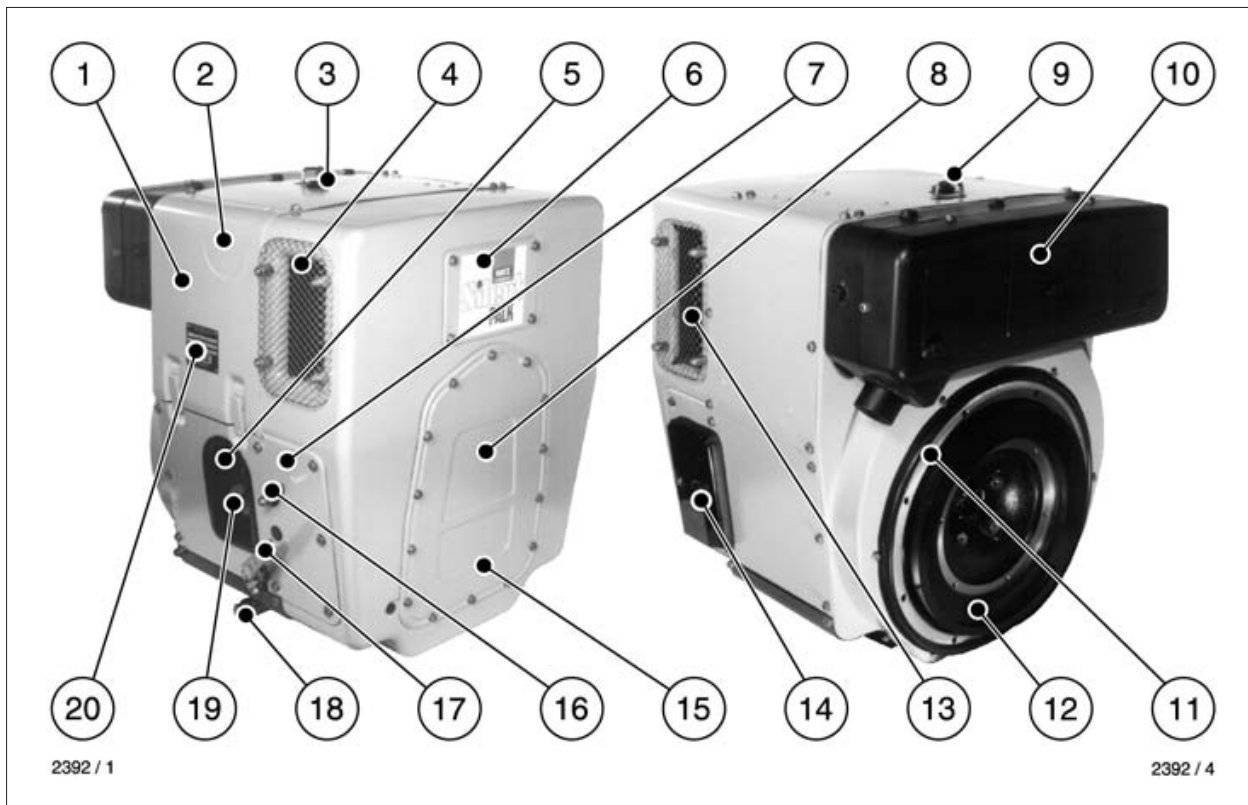

Fully encapsulated version

Engine 1D30C, 1D31C, 1D40C, 1D41C, 1D60C, 1D80C, 1D81C

- | | |
|-----------------------------------------|------------------------------------------------------------------|
| 1 Capsule | 12 Flywheel |
| 2 Decompression lever | 13 Cooling air outlet |
| 3 Cold start-oil priming device | 14 Battery connections and central plug
for electrical system |
| 4 Combustion and cooling air intake | 15 Access to timing cover |
| 5 Oil filter | 16 Stop lever |
| 6 Cleaning opening | 17 Speed control lever |
| 7 Side panels | 18 Oil drain plug |
| 8 Access for starting handle | 19 Oil filling hole and dipstick |
| 9 Lifting bracket, max. 120 kg / 265 lb | 20 Type plate |
| 10 Exhaust silencer, enclosed | |
| 11 Engine flange | |

Engine illustrations

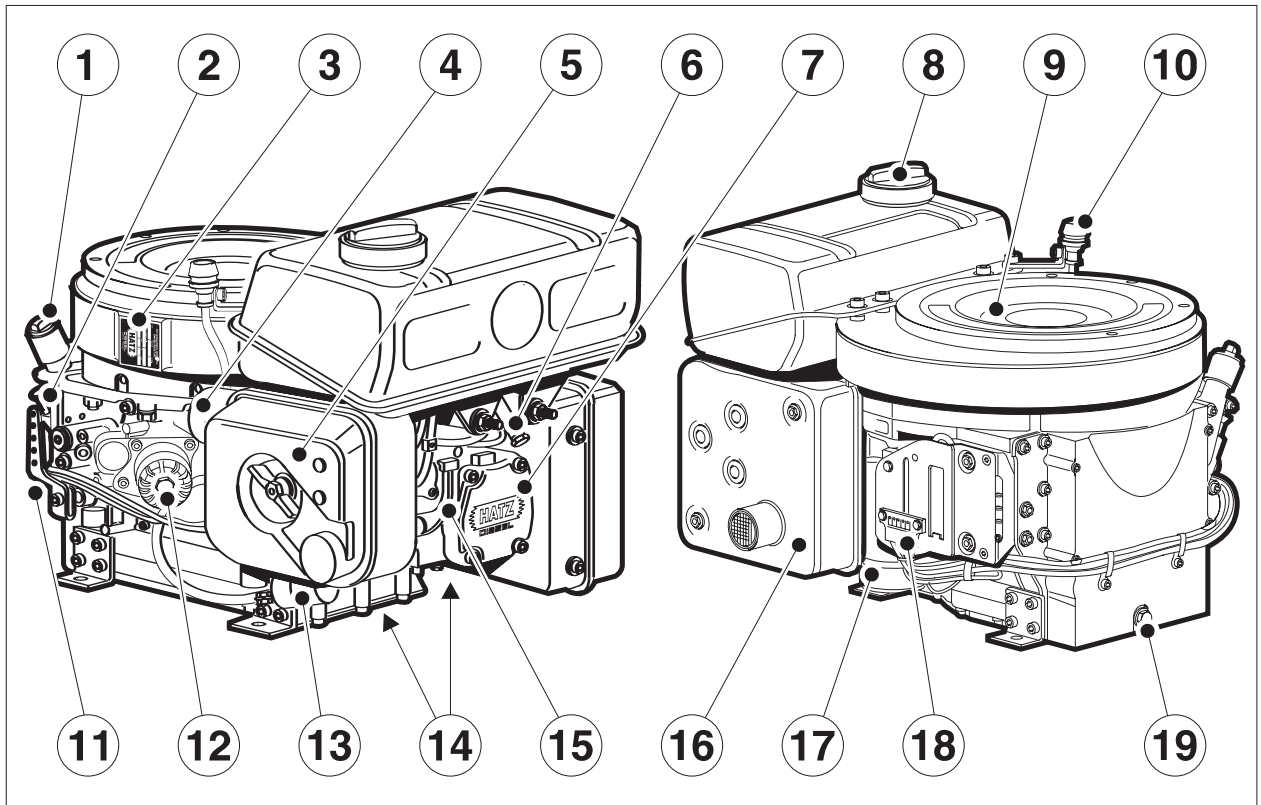

Engine 1D90 V/W

- | | |
|-------------------------------------|-----------------------------------------|
| 1 oil filler cap | 11 speed control lever |
| 2 dipstick | 12 oil filter |
| 3 type plate | 13 fuel filter |
| 4 combustion air intake | 14 cooling air outlet |
| 5 dry type airfilter | 15 decompression lever |
| 6 fuel tank drain plug | 16 exhaust silencer |
| 7 cylinder head cover | 17 electric starter |
| 8 fuel filler cap | 18 central plug f. electrical equipment |
| 9 cooling air inlet | 19 oil drain plug |
| 10 mechanical maintenance indicator | |

Technical data

Type		1D30.. 1D31..	1D40..	A1D35.. A1D40..
Engine models		S, Z, T, U, C	S, Z, T, U,	S, Z, T, U
Mode of operation		Air-cooled four-stroke diesel engine		
Combustion method		Direct-injection		
Number of cylinders		1	1	1
Bore / stroke	mm	86/65	86/65	86/65
Cubic capacity	cm ³	377	377	377
Compression ratio		1D30: 20.5:1 1D31: 21.0:1	20.5:1 22.0:1*	20.5:1
Direction of rotation looking at the flywheel		1D . . S / Z / C 1D . . T / U	counter-clockwise clockwise	
Cooling air required at 3000 min ⁻¹	m ³ /min	6.0	6.0	6.0
Combustion air required at 3000 min ⁻¹	m ³ /min	0.56	0.56	0.56
Oil capacity without oil filter	approx.	1.1	1.1	1.1
with oil filter	ltr.	1.2	1.2	1.2
Difference between „max“ and „min“ markings	approx. ltr.	0.4	0.4	0.4
Oil consumption		Approx. 1% of fuel combustion at full load		
Max. permissible inclination in each direction during operation		approx. 30°	approx. 30°	approx. 30°
Net weight				
Engine models S, Z, T, U	approx.	68	68	74
Engine models C	kg	89	89	–

Model **S**: non-encapsulated, normal system of balancing, counter-clockwise rotation
Z: non-encapsulated, add. system of balancing, counter-clockwise rotation
T: non-encapsulated, normal system of balancing, clockwise rotation
U: non-encapsulated, add. system of balancing, clockwise rotation
C: SILENT PACK, add. system of balancing, counter-clockwise rotation

*Engines in connection with compaction units

Technical data

Type		1D41.. A1D41..	1D50..	1D60..
Engine models		S, Z, T, U, C	S, Z	S, Z, T, U, C
Mode of operation		Air-cooled four-stroke diesel engine		
Combustion method		Direct-injection		
Number of cylinders		1	1	1
Bore / stroke	mm	90/65	97/70	88/85
Cubic capacity	cm ³	413	517	517
Compression ratio		20.0:1	20.0:1	20.5:1
Direction of rotation looking at the flywheel		1D . . S / Z / C 1D . . T / U	counter-clockwise clockwise	
Cooling air required at 3000 min-1	m ³ /min	6.0	6.0	10.5
Combustion air required at 3000 min-1	m ³ /min	0.62	0.78	0.78
Oil capacity without oil filter	approx.	1.1	1.4	1.8
with oil filter	ltr.	1.2	1.5	1.9
Difference between „max“ and „min“ markings	approx. ltr.	0.4	0.5	0.9
Oil consumption		Approx. 1% of fuel combustion at full load		
Max. permissible inclination in each direction during operation		approx. 30°	approx. 30°	approx. 30°
Net weight				
Engine models S, Z, T, U	approx.	68*	76	91
Engine models C	kg	89	–	114

Model **S**: non-encapsulated, normal system of balancing, counter-clockwise rotation
Z: non-encapsulated, add. system of balancing, counter-clockwise rotation
T: non-encapsulated, normal system of balancing, clockwise rotation
U: non-encapsulated, add. system of balancing, clockwise rotation
C: SILENT PACK, add. system of balancing, counter-clockwise rotation

*A1D41: 74 kg

Technical data

Type		1D80.. 1D81..	1D90.
Engine models		S, Z, T, U, C	S, Z, V, W
Mode of operation		Air-cooled four-stroke diesel engine	
Combustion method		Direct-injection	
Number of cylinders		1	1
Bore / stroke	mm	100/85	104/85
Cubic capacity	cm ³	667	722
Compression ratio		20.5:1	20.5:1
Direction of rotation looking at the flywheel		1D . . S / Z / C / V / W 1D . . T / U	counter-clockwise clockwise
Cooling air required at 3000 min ⁻¹	m ³ /min	10.5	10.5
Combustion air required at 3000 min ⁻¹	m ³ /min	1.0	1.1
Oil capacity without oil filter	approx.	1.8	1.8
with oil filter	ltr.	1.9	1.9
Difference between „max“ and „min“ markings	approx. ltr.	0.9	0.9
Oil consumption		Approx. 1% of fuel combustion at full load	
Max. permissible inclination in each direction during operation		approx. 30°	approx. 30°
Net weight			
Engine models S/Z/T/U/V/W	approx.	91	92
Engine models C		121	–

Model S: non-encapsulated, normal system of balancing, counter-clockwise rotation
Z: non-encapsulated, add. system of balancing, counter-clockwise rotation
T: non-encapsulated, normal system of balancing, clockwise rotation
U: non-encapsulated, add. system of balancing, clockwise rotation
C: SILENT PACK, add. system of balancing, counter-clockwise rotation
V: vertical crankshaft, non-encapsulated, normal system of balancing, counter-clockwise rotation
W: vertical crankshaft, non-encapsulated, add. system of balancing, counter-clockwise rotation

Type plate data

Type designation
e.g. _____ | 1 D 80 Z | 36

Engine type _____

Variation _____

Engine No.

Type No. 090 | 16 | 93 | 016883

Engine serial No.:
The serial no. begins with 10 and changes continuously (11, 12) if any major changes are carried out.

Year of production _____

Fabrication No. (continuous) _____

Customer spec. list no. 1)
Customer specification _____

Output in kW 2) _____

Execution code 2) _____

Displacement in cm³ _____

Engine speed
e.g. _____ | 3000 / 60

Nominal speed _____

Speed increase under no-load condition _____

Max no-load speed
3000 + 60 = 3060 min⁻¹

Adjustment instruction 1)
Special adjustm. regarding engine speed, power output etc. _____

Injection pump delivery lift in mm to obtain the required engine output _____

1) If required

2) In special cases only; e.g. engines acc. to Federal Authority for Automobilism

EPA / Carb type plate data

Engine family

4 HZX L.667 V 83

4	HZX	L.667	V	83
---	-----	-------	---	----

Type code
 V = variable speed application
 C = constant speed application
 A = V + C as well

Displacement (in cm³ or liters)
 Diesel engine (Benzin/gasoline = S)
 Manufacturer HZX = HATZ
 Manuf. year (X = 1999, Y = 2000, 1 = 2001,...)

Type / Spec./ FDT

1D81 Z 216B 13.0

1D81	Z	216B	13.0
------	---	------	------

Static timing (begin of fuel delivery)
 Customer specification (only for special equipment)
 Variation
 Engine type

Engine number

073 23 04 083019

073	23	04	083019
-----	----	----	--------

Fabrication No.
 Year of production

Engine serial No.:
 The serial No. begins with 10 and changes continuously if any major changes are carried out

Type No.

Engine speed

2950 290

2950	290
------	-----

Speed increase under no-load condition
 Nominal speed

0.98 10.4

0.98	10.4
------	------

Rated power in kW
 Injection pump delivery lift in mm to obtain the required power output

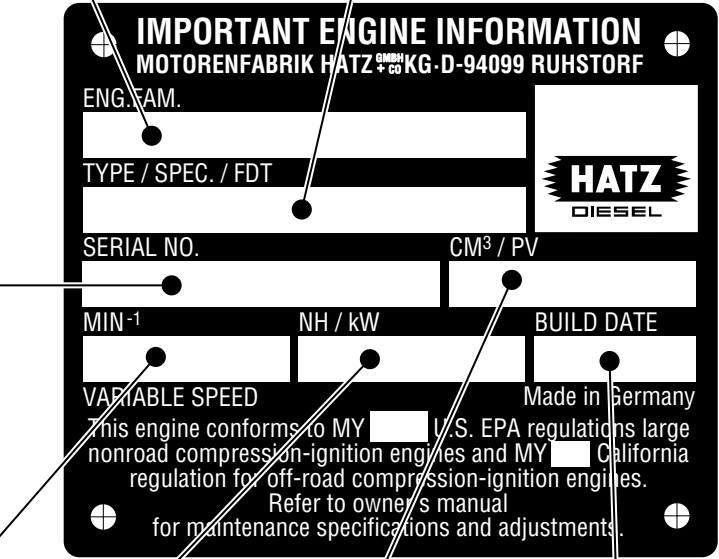

0667 189A

0667	189A
------	------

Special adjustment instruction
 Displacement in cm³

Manuf. year

0504

05	04
----	----

Year
 Month

Lubrication oil circuit

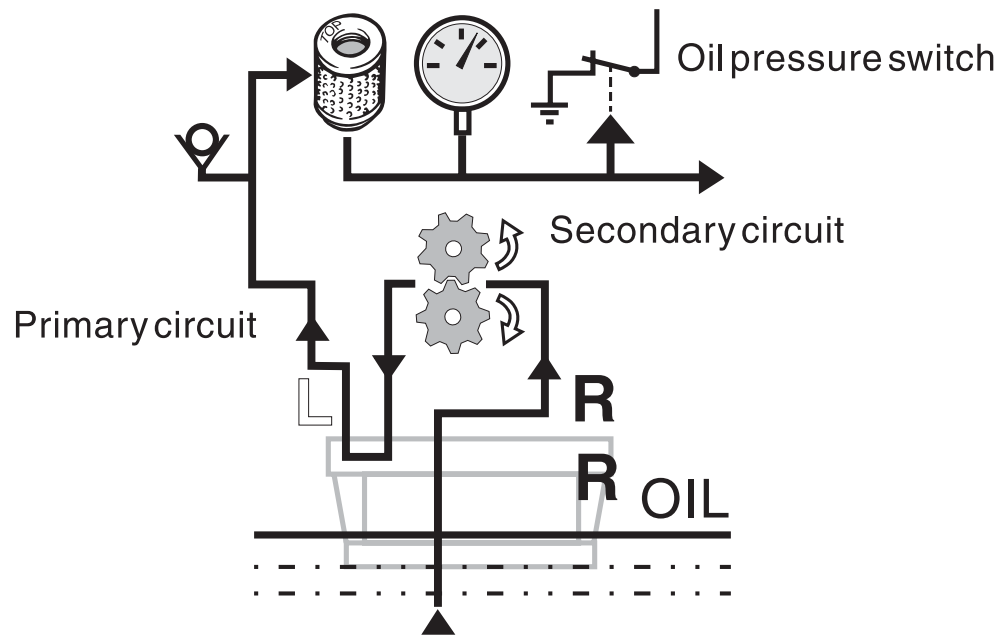
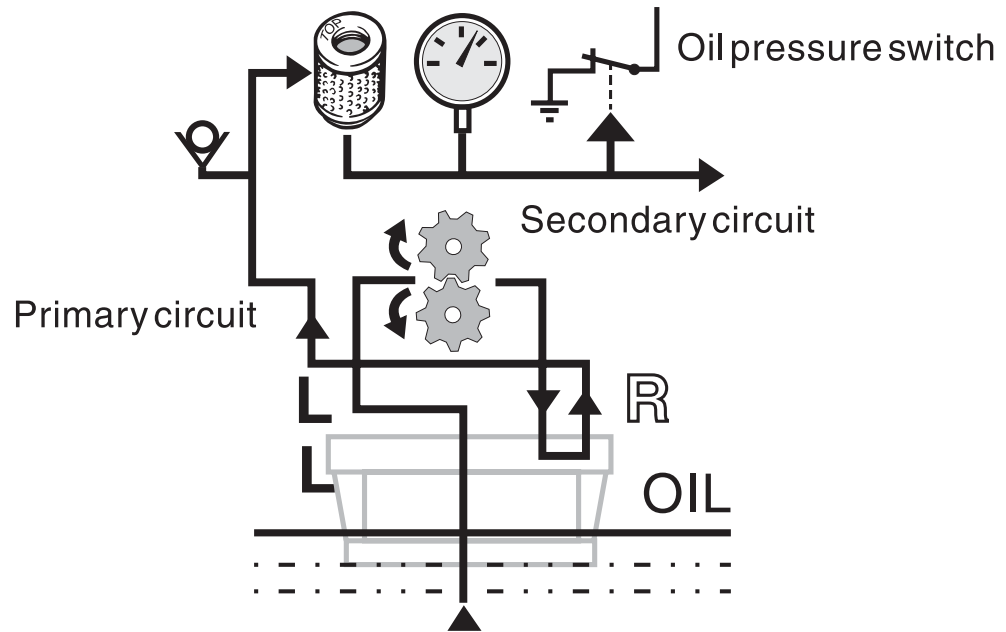

Special tools and workshop equipments



Engine series 1 D . . (SUPRA)

Nr.	Ident-Nr.	Bezeichnung	Verwendung bei Typen	
			30-50	60-90
1	644 345 90	Clip tool for lead plugs	x	x
2	630 815 00	Allen socket 6 mm lg 1/2"	x	x
3	629 301 00	Clamp for pushrod tube	x	—
3	629 102 00	Clamp for pushrod tube	—	x
4	627 501 00	Retainer for governor spring	x	x
5	632 579 00	Adjustment wrench	x	x
6	629 223 01	Valve lifter	x	x
7	631 392 00	Mandrel for valve stem seal cap	x	x
8	603 823 91	Multi-purpose extractor	x	x
9	629 016 02	Punch for main bearing gov.-side	—	x
9	629 298 02	Punch for main bearing gov.-side	x	—
10	627 496 02	Punch for outer camshaft bushing	x	x
11	627 398 02	Punch for main bearing flywheel side	—	x
11	629 299 02	Punch for main bearing flywheel side	x	—
12	629 284 00	Heating insert for gear/stubshaft	x	x
13	627 494 00	Drift punch for camshaft bushing	x	x
14	634 147 00	Comb. extractor f. gear + stubshaft	x	x
15	627 495 02	Assembly device for oil pump shaft	x	x
16	627 500 00	Torx-socket TX 30 – 1/2"	x	x
17	631 133 01	Ring spanner 18 x 19 for starter	x	x
18	665 030 91	Spill device for injection pump M18x1.5	x	x
18	625 401 90	Spill device for injection pump M20x1.5	x	x
19	612 087 00	Dial gauge – 1/100 mm	x	x
20	612 090 01	Piston ring pliers	x	x
21	626 383 00	Piston ring clamp.device Ø 70-100 mm	x	x
22	639 477 00	Measuring device for injection pump	x	x
23	636 421 00	Pliers for EPA - radial (tamper-resistant)	x	x
24	640 564 00	Pliers for EPA - axial (tamper-resistant)	x	x
25	626 753 91	Impact hammer with fittings	x	x

Special tools and workshop equipments

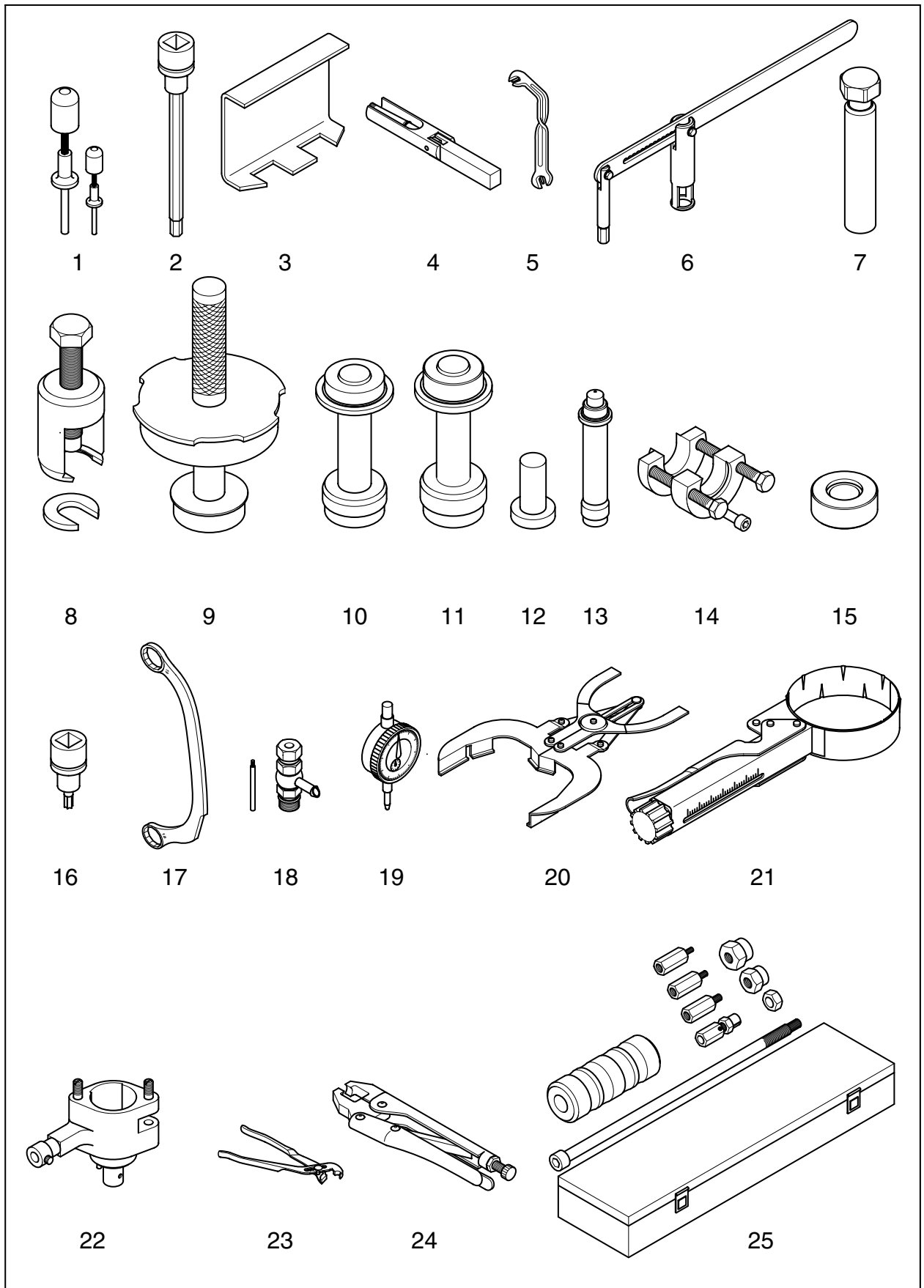

Special tools and workshop equipments



Engine series 1 D . . (SUPRA)

Nr.	Ident-Nr.	Bezeichnung	Verwendung bei Typen	
			30-50	60-90
26	633 013 00	Forcing screw for centrif.-clutch	x	x
27	620 926 92	Oil pressure gauge 0... 6 bar	x	x
28	630 094 90	Test nozzle 400 bar / 5800 psi	x	x
29	634 142 00	Honing tool	x	x
30	624 838 92	Rev.-counter for fuel press.-pipe	x	x
31	641 610 90	Testbox for instrument box	x	x
32	633 178 00	Components testbox	x	x
33	632 913 00	High-pressure supply pump	x	x
34	624 863 02	Hydraulic lift trolley	x	x
35	625 682 01	Revolvable fixing - basic part	x	x
36	625 751 90	Console for revolvable fixing	x	x
37	631 300 00	Revolvable fixing - adaptor engine side	x	x
38	644 991 01	Socket wrench for lock nut	x	x
39	645 020 00	Punch for tab washer	x	x

Special tools and workshop equipments

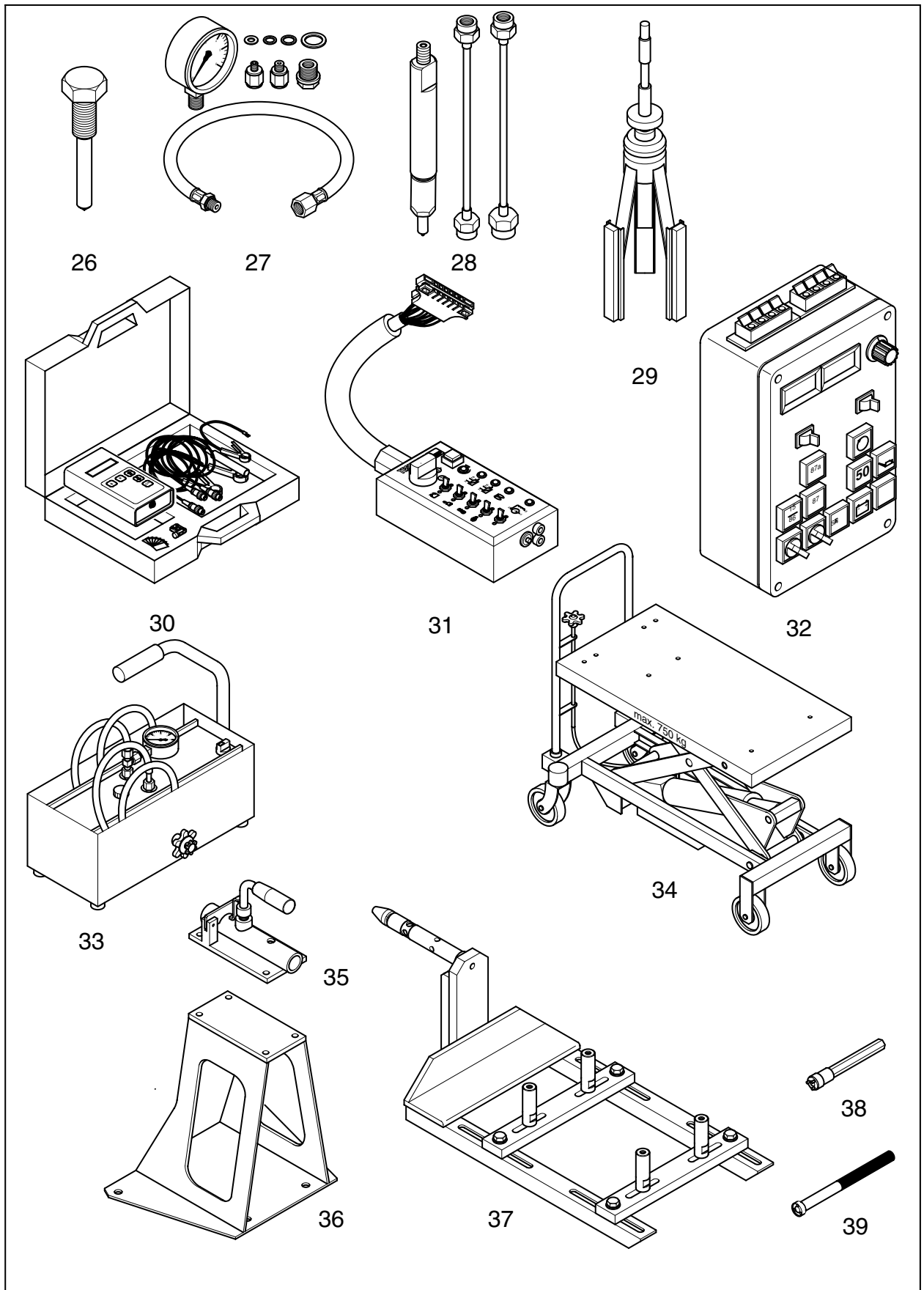

Jointing material / Sealing and bonding agents

Sealing and bonding agents are available from HATZ for use in maintenance and/or repair works.

All items listed below may be ordered as individual spare parts.

Refer to appropriate spare parts list for ordering.

Application of sealing and bonding agents:

The letter coding in the drawings indicates which agents should be applied when fitting the part referred to.

See the following list for decoding the material; this list is the same as already being used with all other service literature including spare parts list.

A =	502 230 01	Loctite Activator	500 ml
B =	502 231 00	Loctite 573	50 ml
C =	502 232 00	Loctite 601	50 ml
D =	502 233 00	Loctite 221	50 ml
E =	502 234 00	Loctite 648	10 ml
F =	502 238 00	Technicoll 8058	750 g
	+ 502 239 00	Technicoll 8367	750 g
G =	502 565 01	Loctite IS 407	20 g
H =	502 825 01	Silicon sealer	30 ml
J =	502 830 02	Anti-Seize compound	1000 g
K =	503 426 00	High-temp. lub.-grease	100 g
L =	502 566 00	Silicon sealer	100 g
M =	504 851 00	Polishing paste K 240	80 ml

2. Additional equipment

A 01.00 Fuel

A 01.10 Fuel tank



Preparations: –

Dismantling:

- Loosen drain plug **1** and drain off fuel or close off fuel supply pipe **2**.
- Remove (pull off) fuel hoses **2...3** from fuel filter and fuel tank.
- Unscrew respectively remove all retaining components in question, including fuel tank **4**.
- Remove fuel filter **5** with retaining components if necessary.

Inspection / repair:

- Visual inspection.
 - Check fuel tank for cracks and/or any other damage.
 - Check all rubber parts for ageing etc.
- Maintenance according to instruction book!

Assembly:

- Re-assemble and re-connect fuel tank **4** and fuel filter **5** as well as fuel hoses **2...3**. Tighten all retaining items uniformly to obtain a stress free assembly of the fuel tank.
- Remove clamp tool and/or tighten drain plug **1**.

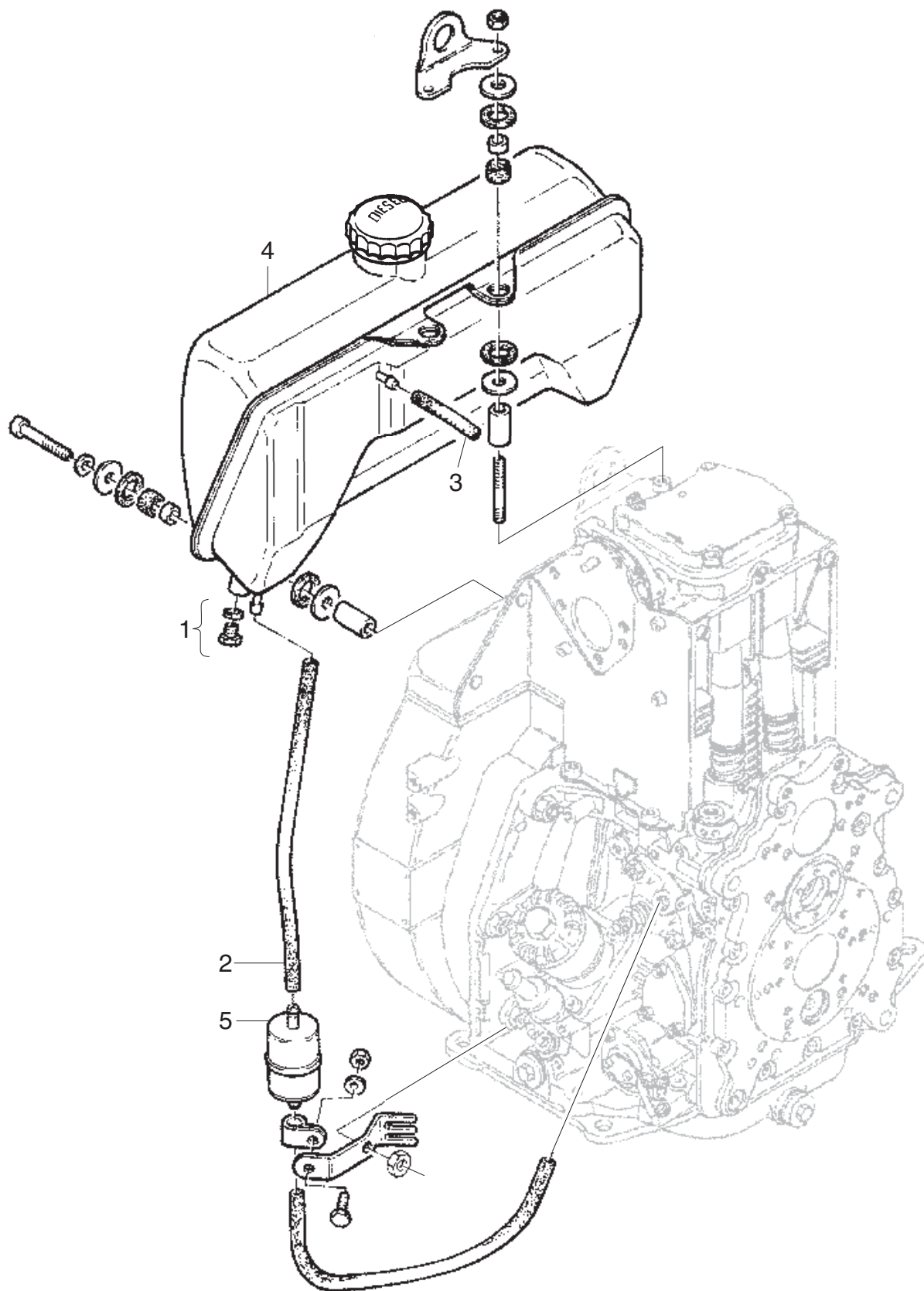

A 01.00 Fuel

A 01.40 Fuel feed pumps

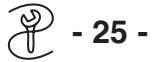

I. Fuel feed pump

General:

When connecting the fuel feed pump take care for arrangement of suction and supply hose.

Preparations:

- Disconnect fuel supply from fuel feed and injection pump.

Dismantling:

- Remove in numerical sequence **1 ... 3**.

NOTE:

When removing the upper nut, make sure that the stud **4** does not turn in the crankcase as it serves as the anchor pin for the governor lever retainer spring. If turning of the stud cannot be avoided, remove the spring from the pin. The front cover must be removed to remove the spring.

Ref.: Chapt. M 11.00

Inspection / repair:

- Visual inspection.

For further repair proceed as follows:

- Remove in numerical sequence **5 ... 14**.

Required only if irregularities such as poor suction / pumping action i.e. contaminated strainer or leaks have been noted.

- Check and replace all parts in question.

Assembly:

- Pre-assemble in reverse sequence **14...5**.
- Assemble in reverse sequence **3 ... 1**.
- Ensure actuating lever **16** is in bottom position and „O“-Ring **3** remains in its groove when assembling.
- After installation and a short test run, check the fuel system for leaks.

II. Fuel feed pump drive

General:

Models Z/U/C

Bushing **15** is replaced by the actuating lever **16**.

Models S/T

Plug **17** is replaced by the plug **18** with ring groove.

Preparations:

- Remove fuel feed pump.
 - Remove timing cover.
- Ref.: Chapt. M 11.00

Dismantling:

- Remove part **20/21** and lever **16**.
 - Remove shaft **19**.
- For removal use tool - **25** -
Plug **18** remains in crankcase.

Inspection / repair:

- Visual inspection.
- Check parts for wear and/or any other damage.

Assembly:

- Assemble in reverse sequence .
 - Press in shaft **19** to a protrusion of $52 \pm 0,5$ mm.
Extractor thread must face front!Models Z/U/C
- Ensure all gear timing marks match!
- Finish assembling.

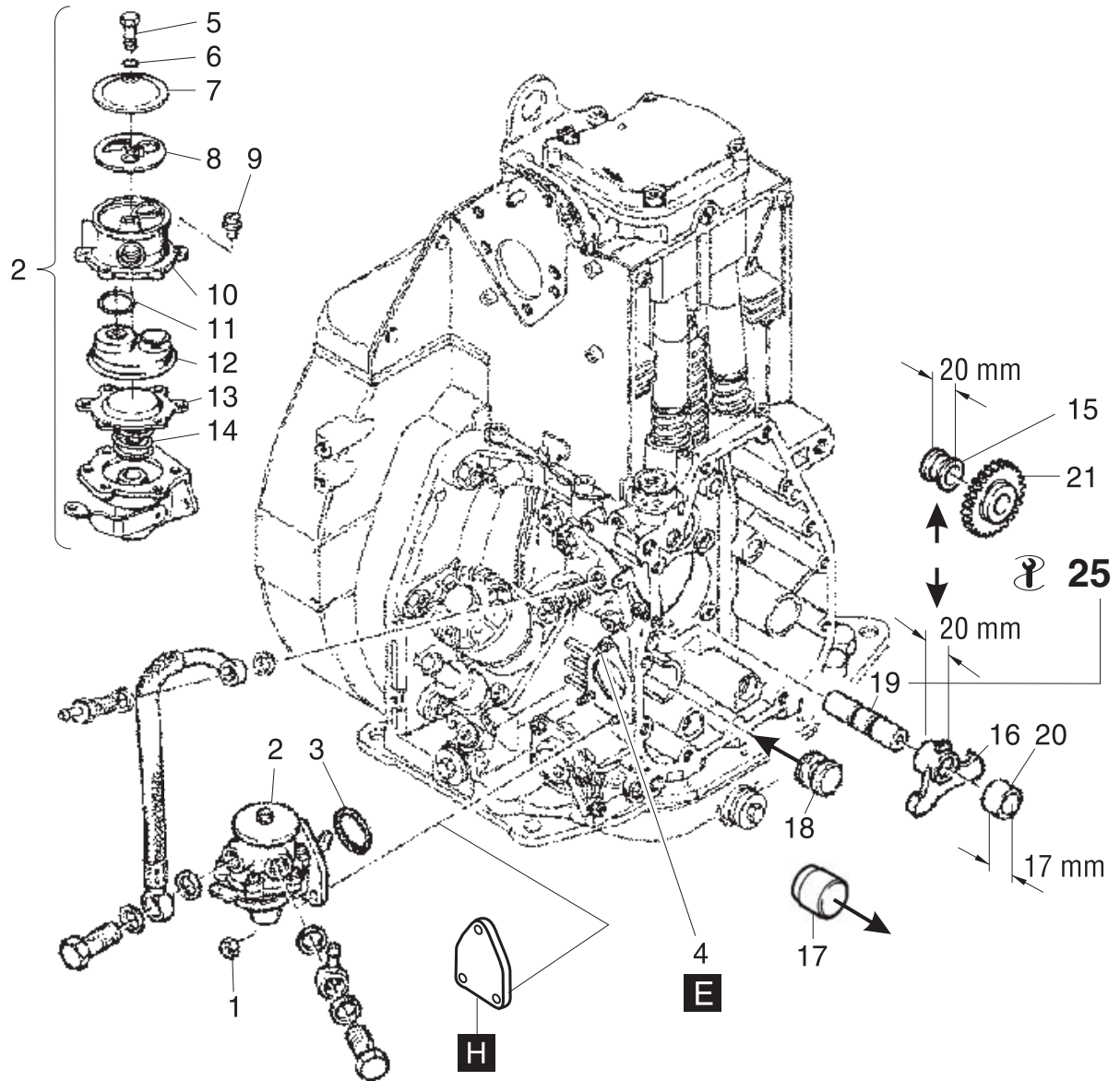

A 02.00 Combustion air

A 02.10 Oil bath air filters



General:

The oil bath air filter is fitted by means of an intermediate flange which adapts from the triangle-type flange at cylinder head to the twin-screw flange of oil bath air filter. This flange also holds the glow plug in case a pre-heating system is fitted.

Preparations: –

Dismantling:

- Disconnect cable connection from glow plug if fitted.
- Remove in numerical sequence **1...9**. Studs and Hex.-head screw plug or glow plug may remain.
Don't tip oil bath air filter !

Inspection / repair:

- Visual inspection.
- Check air filter body for cracks and/or any other damage.

Maintenance according to instruction book!

NOTE:

Never „repair“ an oil bath air filter by welding/soldering etc.

It causes total damage to the part and may lead to engine failure!

Assembly:

- Assemble in reverse sequence **9...1**. Ensure the correct amount of gaskets are used and parts seal properly to avoid infiltrated air.
When fixing the oil bath air filter take care for correct position of kidney-shaped washers **3**, convex side faces retaining nuts **1**.
- Reconnect cable connection to glow plug if so fitted.

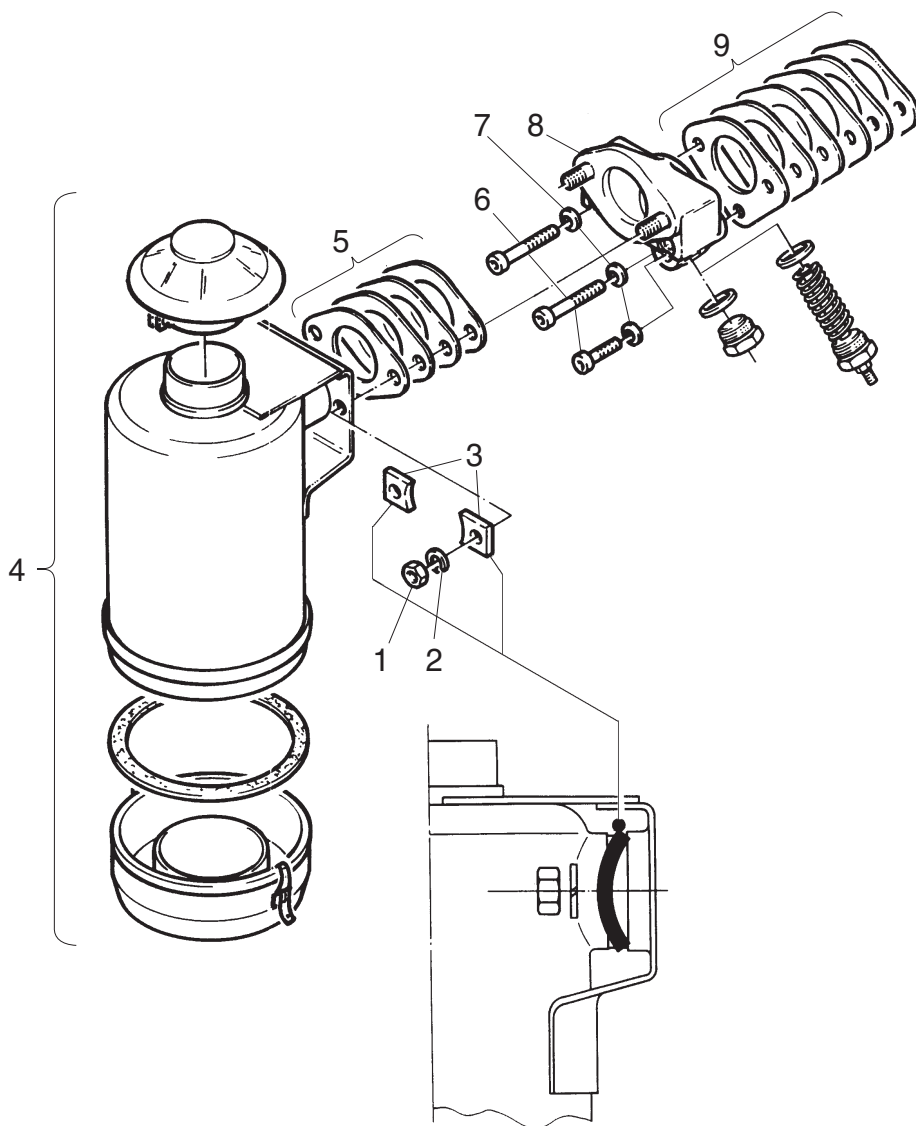

A 02.00 Combustion air

A 02.11 Dry type air filters



Version A 02.11.1

Fixation of filter element and cover by flat washers and Hex.-nuts.

Preparations: –

Dismantling:

- Remove in numerical sequence **1...10**.

Inspection/repair:

- Visual inspection.
- Check filter element **6** and sealing strip around cover **3**.

Maintenance according to instruction book!

Assembly:

- Assemble in reverse sequence **10...1**.
Torque to specification!

NOTE:

Mind total length of bushing **4** and washer **5** respectively length of bushing **4** without washer.

Take care for correct position of insulating flange in between, correct amount of gaskets and proper sealing of all parts to avoid infiltrated air.

Conversion:

Possible to current standard in case all parts in question become replaced.

Version A 02.11.2

Fixation of filter element separately by retaining plate, flat washers and Hex.-nuts.

Preparations: –

Dismantling:

- Disconnect cable connection from heater flange if so fitted.
- Remove in numerical sequence **1...12**.
- If necessary dismantle cover retaining screw to replace sealing sleeve (rubber) between screw cap and cover.

Inspection / repair:

- Visual inspection.
- Check filter element **6** and sealing strip around cover **1**.

Maintenance according to instruction book!

Assembly:

- Assemble in reverse sequence **12...1**.
Torque to specification!

NOTE:

Take care for correct position of insulating flange in between, correct amount of gaskets and proper sealing of all parts to avoid infiltrated air.

- Reconnect cable connection to heater flange if so fitted.

Conversion:

Possible to current standard in case all parts in question become replaced.

A 02.11.1

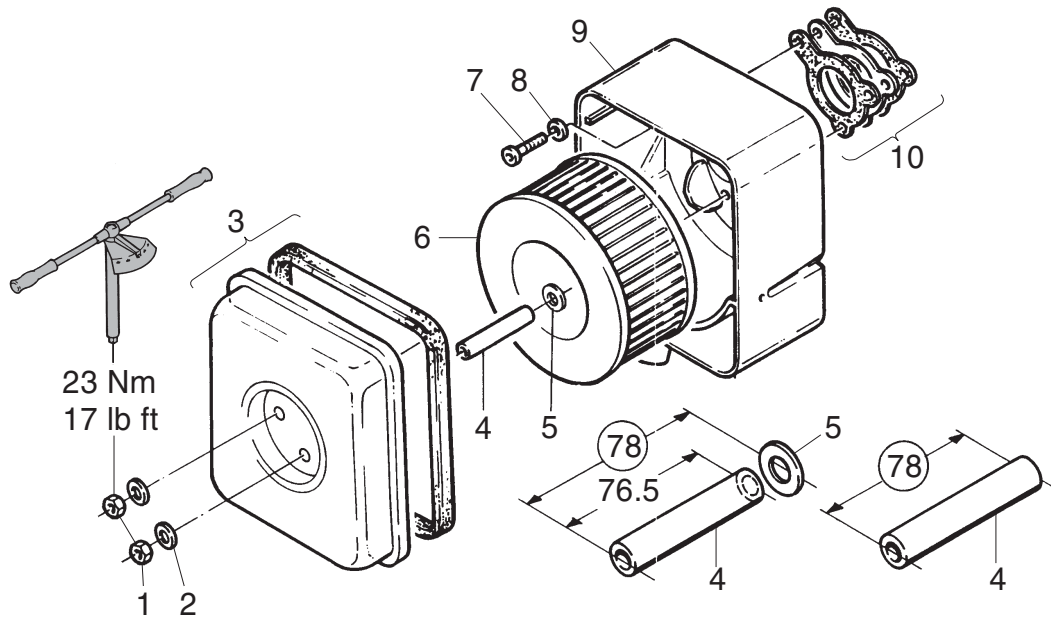

A 02.11.2

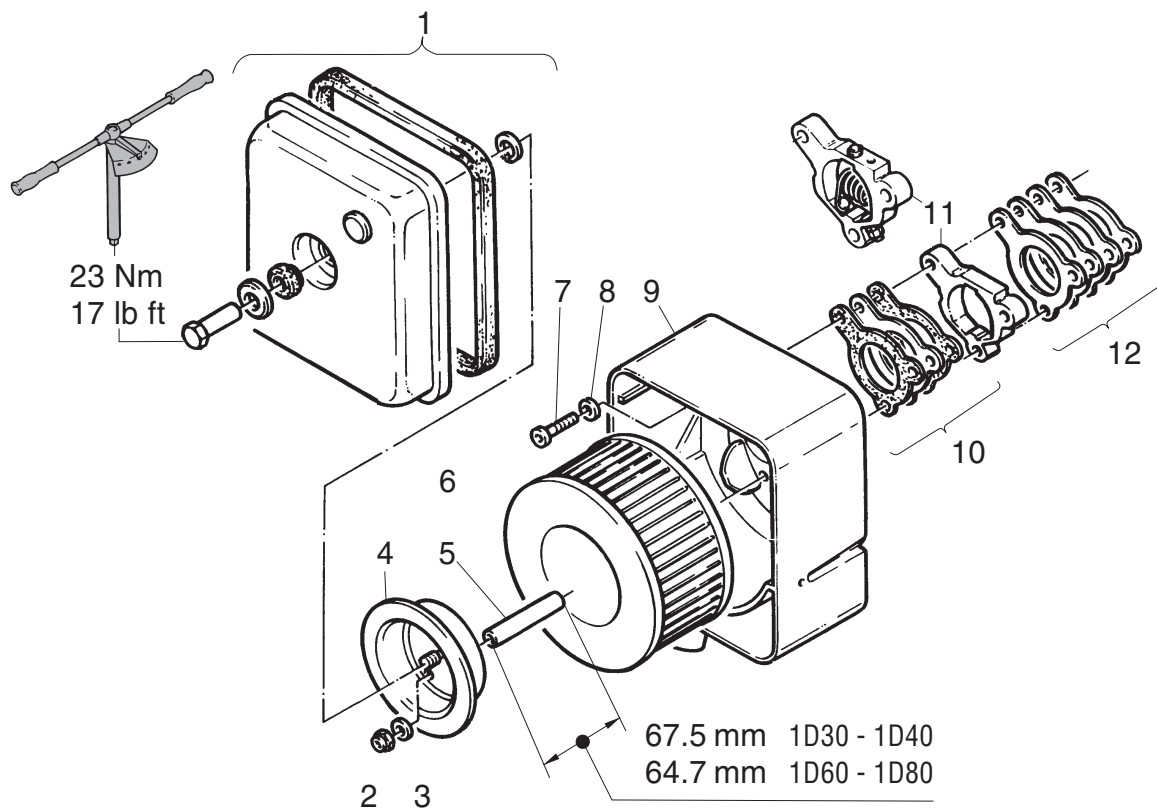

A 02.00 Combustion air

A 02.11 Dry type air filters



Version A 02.11.3

Fixation of filter element by front cover assembly.

Preparations: –

Dismantling:

- Disconnect cable connection from heater flange if so fitted.
- Remove in numerical sequence **1...11**.
- If necessary dismantle cover retaining assembly to replace sealing sleeve (rubber) between centering and front cover.

Inspection / repair:

- Visual inspection.
- Check filter element **2** and sealing strip around cover **1**.

Maintenance according to instruction book!

Assembly:

- Assemble in reverse sequence **11...1**.
Take care for correct position of insulating flange in between, correct amount of gaskets and proper sealing of all parts to avoid infiltrated air.
- Reconnect cable connection to heater flange if so fitted.

Version A 02.11.4 (A 1 D...)

Fixation of filter element separately by retaining plate, flat washers and Hex.-nuts.

Preparations: –

Dismantling

- Disconnect cable connection from heater flange if so fitted.
- Remove in numerical sequence **1...15**.

Inspection / repair:

- Visual inspection.
- Check filter element **8**, „O“-Ring around retaining cover **11** and insulation plate **12**.
Maintenance according to instruction book!

Assembly:

- Assemble in reverse sequence **15...1**.
Take care for correct position of insulating flanges in between, correct amount of gaskets and proper sealing of all parts to avoid infiltrated air.
- Reconnect cable connection to heater flange if so fitted.

A 02.11.3

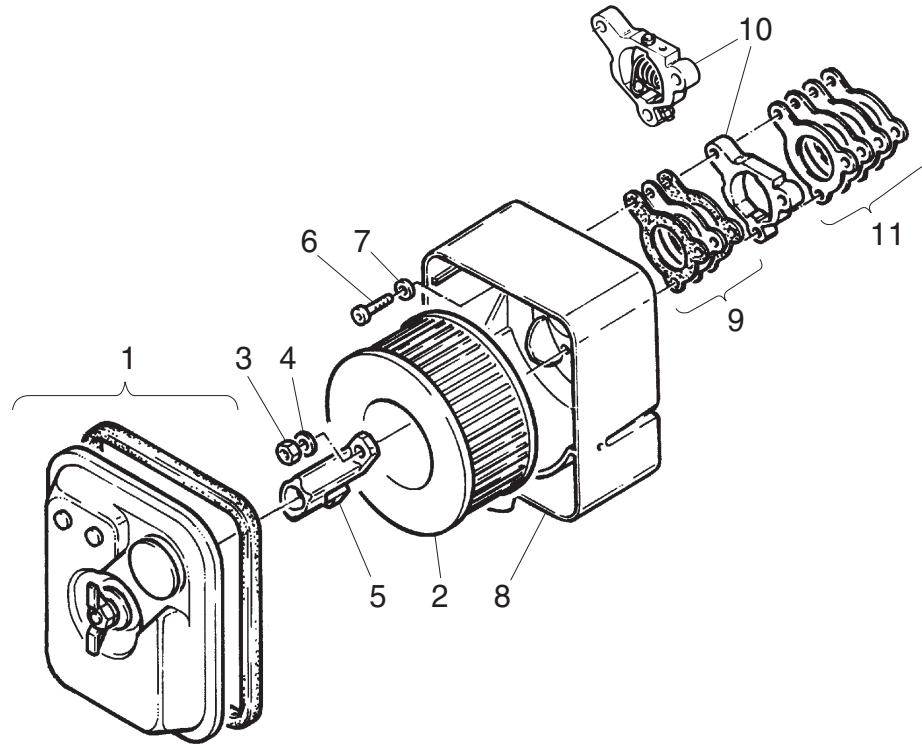

A 02.11.4

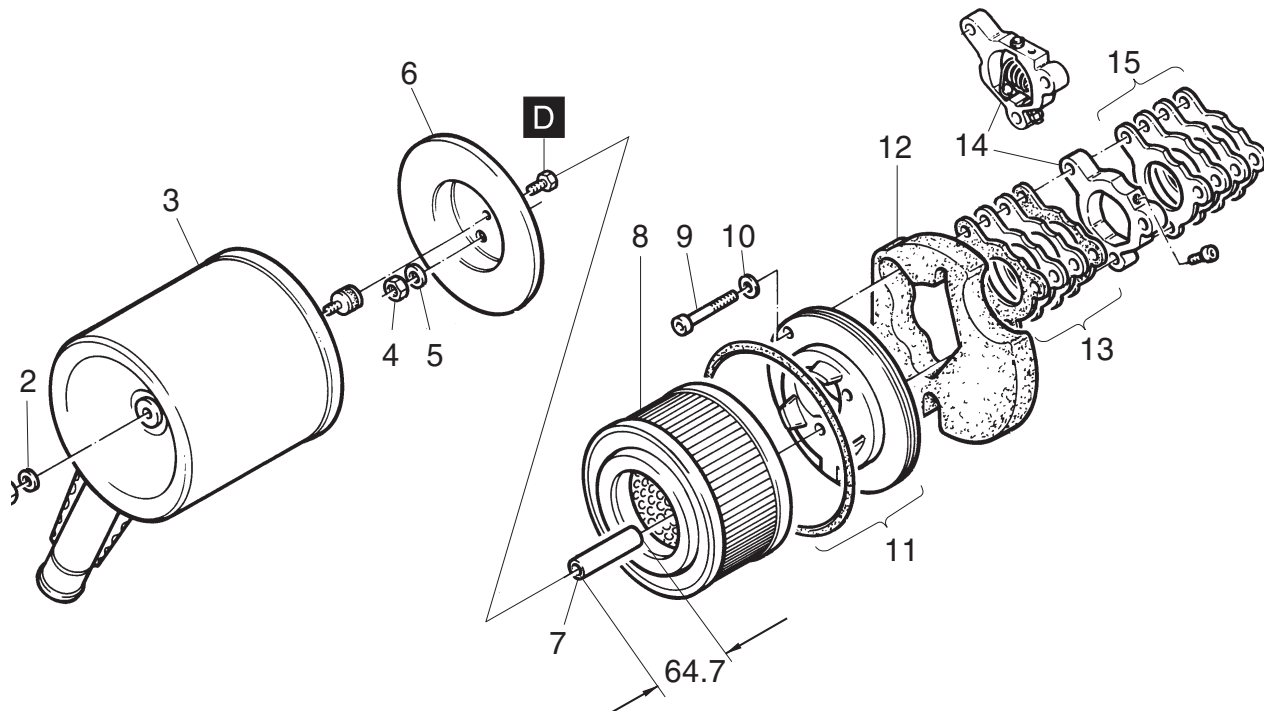

A 02.00 Combustion air

A 02.13 Service indicators; vacuum gauges



Preparations: –

Dismantling:

- Remove in numerical sequence **1...2**.
- Remove in numerical sequence **3...6**.
Ensure not to lose flap valve **6**!
- Remove in numerical sequence **7...10**.
Hose pulled off from banjo hose nipple during removal.
Hose nipple connection **16** may remain.
1 D 60 - 80 - 81 only:
- Snip cable strap **11**.
- Remove in numerical sequence **10/12...15**.
Parts may remain as a unit.

Inspection / repair:

- Visual inspection.
 - Check maintenance indicator by sucking and releasing at the end of hose or adapter for indication.
Sucking = indicator „CLOSED“
(green section ring not visible)
Release = indicator „OPEN“
(green section ring visible).
 - Check all rubber parts for material ageing etc.
 - Check all parts in question for proper fit.
- Maintenance according to instruction book!

Assembly:

- Assemble in reverse sequence **15...10**.
1 D 60 - 80 - 81 only!
 - Cable strap remains loose.
 - Connect hose **10** to hose nipple connection and assemble parts **9...7**.
 - Put flap valve **6** onto pin location of retaining bracket **5**.
 - Assemble in reverse sequence **5...3**.
Ensure flap valve remains in position during assembly!
 - Check function of flap valve in connection with maintenance indicator as follows:
 - Press indicator cap.
Cap has to remain for a short term in „CLOSED“ position.
Green section ring not visible!
- NOTE:
A minimum time of 3 s between „CLOSED“ and „OPEN“ has to be obtained.
- Lift flap valve.
Cap has to come to „OPEN“ position.
Green section ring visible!
Ensure the indicator reacts as described.
If not, check seating position in housing or replace flap valve.
 - Assemble in reverse sequence **2...1**.
1 D 60 - 80 - 81 only:
 - Tighten cable strap.

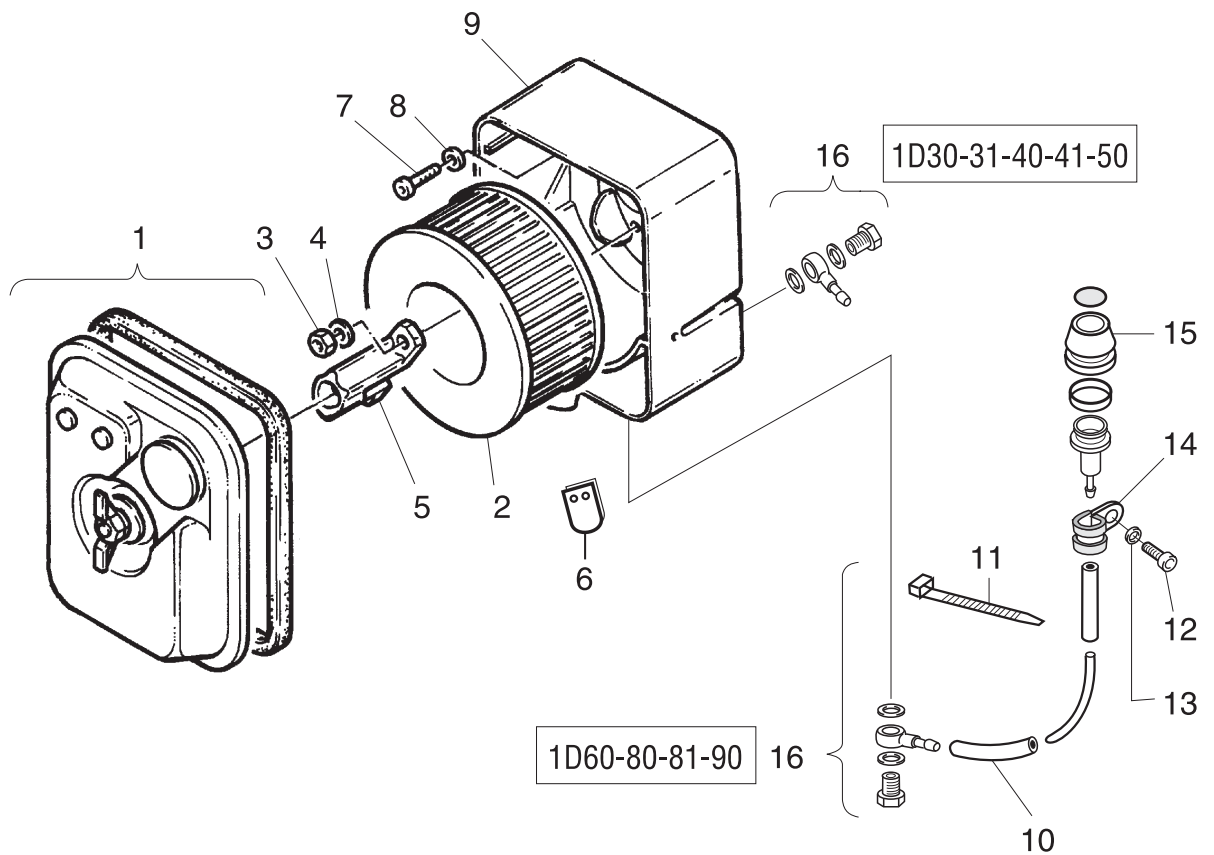

A 02.00 Combustion air

A 02.20 Pre-cleaners; cyclons



Version A 02.20.1

Cyclon fitted at bottom side inlet port.
Front inlet port and through holes plugged.

Preparations: –

Dismantling:

- Loosen hose clip and remove cyclon **1**.

Inspection / repair:

- Visual inspection.
 - Check closing plugs for tightness.
- Maintenance according to instruction book!
Don't use oily cleansers.

Assembly:

Place cyclon **1** and tighten hose clip.

Version A 02.20.2

Cyclon fitted to front side inlet port.
Bottom inlet port closed.

Preparations: –

Dismantling:

- Remove front cover **1** including cyclon system. Closing cap at bottom side remains.
- Remove in numerical sequence **2...5**.

Inspection / repair:

- Visual inspection.
- Check rubber elbow for material ageing, replace if necessary.

Maintenance according to instruction book!
Don't use oily cleansers.

Assembly:

- Assemble in reverse sequence **5...1**.

A 02.20.1

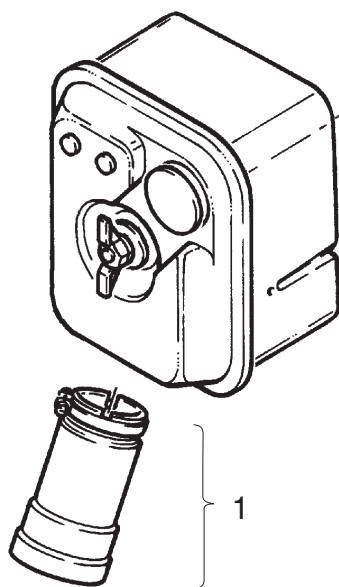

A 02.20.2

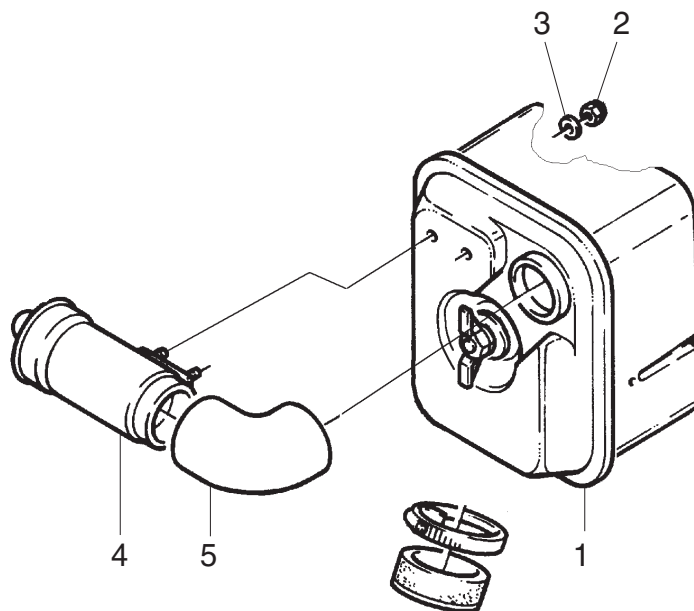

A 03.00 Exhausts

A 03.12. Exhaust-silencers, high performance / Protection guard

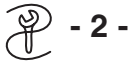

Version A 03.12.1

Exhaust silencer fitted in connection with studs, flat washers and hex.-nuts.

Version A 03.12.2

Fixation by Allen screws.

Preparations:

- Remove protection guard if so fitted.

Dismantling:

Version A 03.12.1

- Remove in numerical sequence **1...5**.
Bushings **4** are fitted only in connection with an exhaust silencer with recessed bores to prevent the silencer getting loose.

Version A 03.12.2

- Remove in numerical sequence **1...3**.
For removal use tool - 2 -

Inspection / repair:

- Visual inspection.
- Check exhaust silencer for possible cracks and/or any other damage.

Assembly:

- Assemble in reverse sequence.
Apply lubricant as specified!
Torque to specification!
- Ensure gasket-kit is fitted in correct sequence i.e. the creased gaskets face towards exhaust silencer.
- Assemble protection guard if so fitted.

Conversion:

Possible to current standard.

Protection guard

General:

The fixation of the guard has been modified to avoid breaks around the fixation due to excessive vibrations.

Preparations:–

Dismantling:

- Remove in numerical sequence **1...3/4**.

Inspection / repair:

- Visual inspection.
- Check guard around fixation for breakage.

Assembly:

- Assemble in reverse sequence **4/3...1**.
Use anti-seize compound as specified.
Ensure the concave side of the curved washers **4** face towards guard **3**.

A 03.12.1

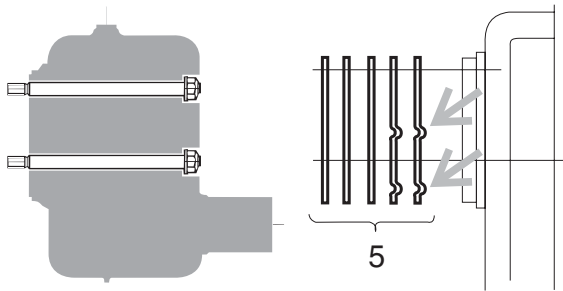

A 03.12.2

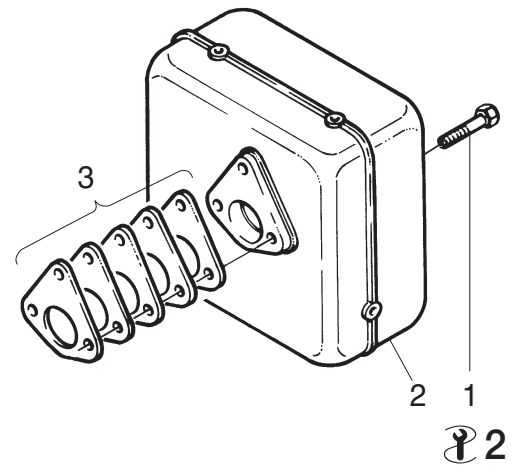
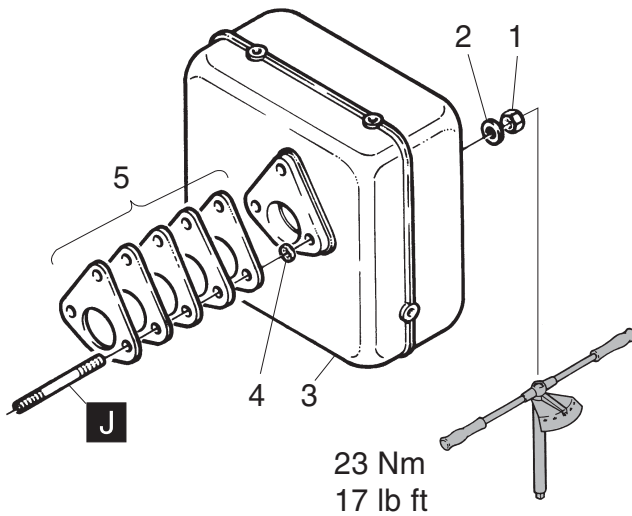
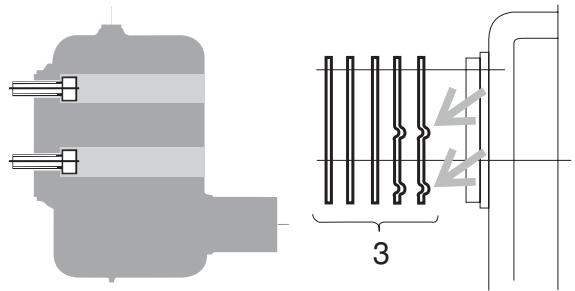

A 12.30.1

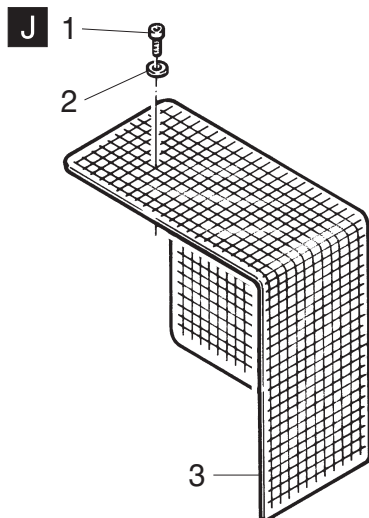

A 12.30.2

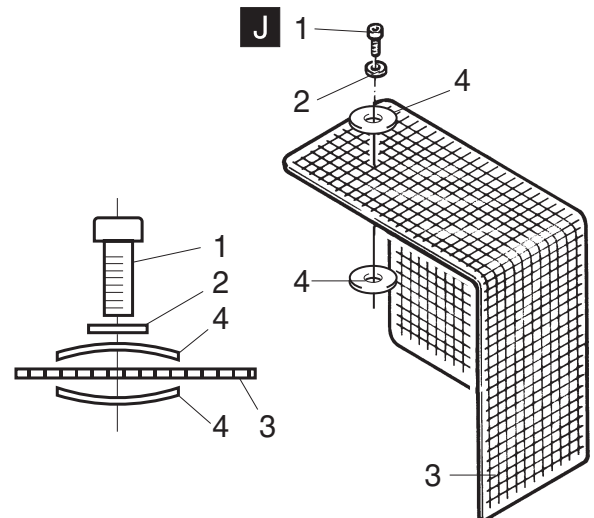

A 04.00 Start mechanical / pneumatic

A 04.10 Starting handles without supports



Version A 04.10.1

Standard starting handle:

Replaceable at any time by a safety starting handle if required or specified.

ATTENTION !

Take care, a worn shaft or broken handle can cause serious injuries.

Preparations: –

Dismantling: –

Inspection / repair:

- Visual inspection.
 - Check shaft **1** and handle **2** for wear and/or any other damage. Handle **2** can be replaced by removing and replacing snap ring **3**.
- In case shaft **1** is worn replace complete starting handle.

A 04.10.1

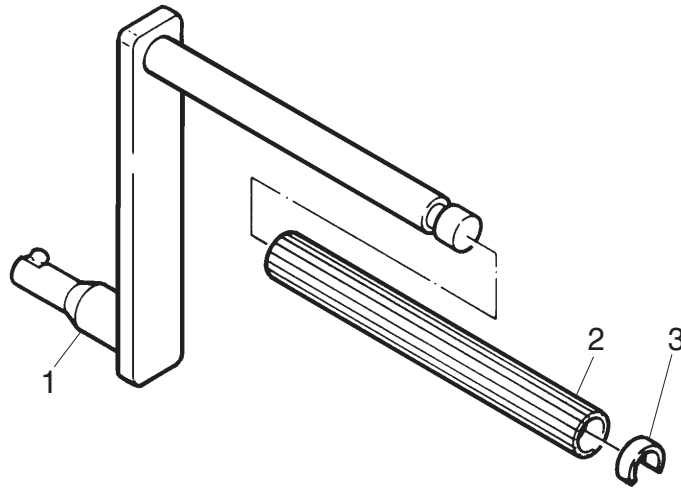

A 04.10.2

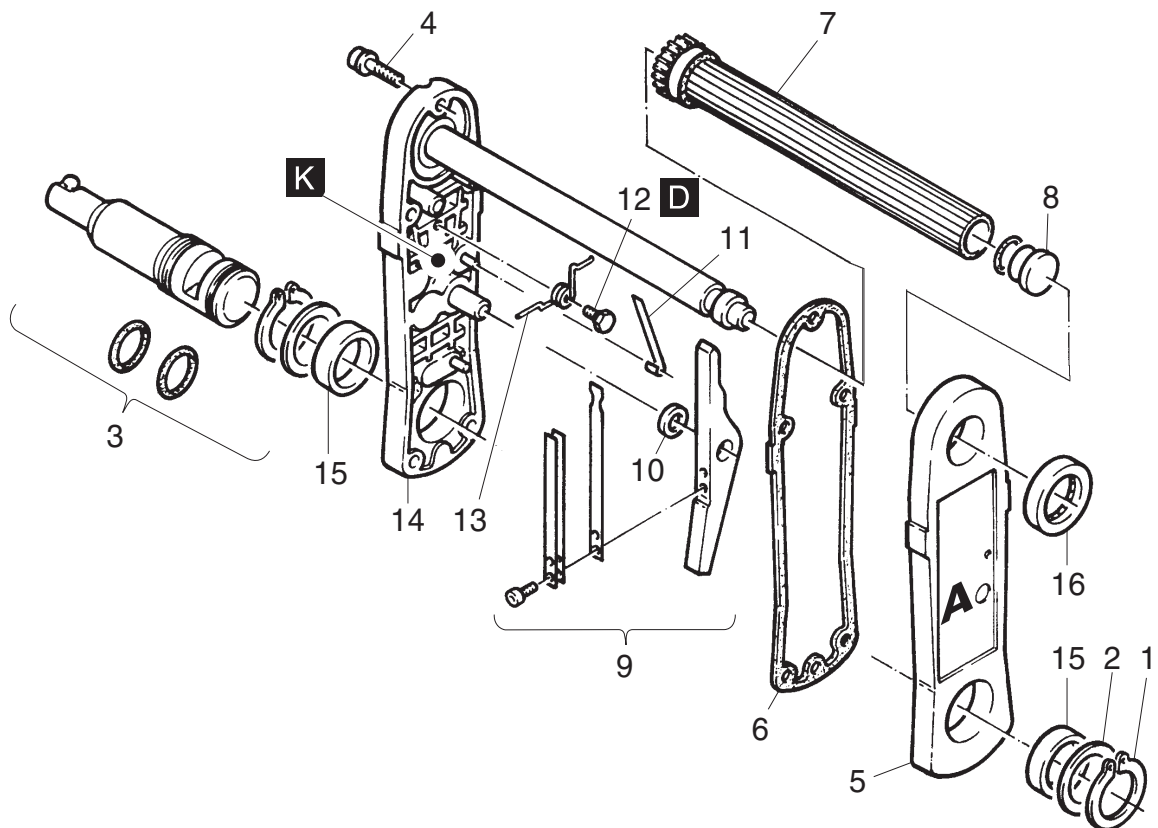

A 04.00 Start mechanical / pneumatic

A 04.10 Starting handles without supports



Version A 04.10.2

Anti-kick-back starting handle, specified as type **A** for **1 D.. S/Z/C** engines.

ATTENTION !

Take care, a worn shaft or broken handle can cause serious injuries.

Preparations: –

Dismantling:

- Remove in numerical sequence **1...3**.
- Remove Allen screws **4** and cover **5**.
Remove cover carefully to avoid plate spring **11** jumping out.
Risk of injury !
- Remove in numerical sequence **6...10**.
- Hold leg spring **13** firmly down to avoid release of spring tension.
- Pull plate spring **11** off its pin location and out of the hook shaped part of the leg spring **13**.
- Release spring tension of leg spring using a screw driver or similar tool.
Risk of injury!
- Remove in numerical sequence **12...13**.
Housing **14** remains with all fixed parts.

Inspection / repair:

- Visual inspection.
If cover **5** and housing **14** are worn or damaged, use a new starting handle.
Bearing bushings **15** and oil seal **16** can be replaced.
- Check handle **7** for wear and/or damage concerning teeth and/or handle.
Take care not to damage teeth when a new end plug **8** becomes fitted.
End plug has to be existent !
- Check conditions of bushing and plate spring on lever **9**.

- Check condition of plate spring **11** and leg spring **13**.
- Check starting handle shaft **3** for wear and/or any other damage.
Replace worn shaft and hardware if necessary.

Assembly:

- Assemble in reverse sequence **13...12**.
Apply locking agent as specified!
Ensure leg spring is not squeezed, straight end catches groove in location pin.
- Force leg spring **13** against spring tension until hook shaped part catches end position at inside of through hole eye.
- Hold leg spring **13** firmly down to avoid release of spring tension.
- Place plate spring **11** into hook shaped part of leg spring **13** respectively onto location pin.
Rolled end of plate spring faces centre of housing.
- Put lever **9** onto location bolt.
- Place handle **7 / 8** onto handle shaft.
Check handle-teeth, lever and plate springs for free moving.
- Apply approx. 50g/1.8 oz. of grease as specified into cavity of housing **14** respectively over all mechanical parts.
- Place gasket **6** and cover **5** carefully over handle **7** onto housing **14**.
- Place and tighten Allen screws **4** cross-wise and uniformly.
- Assemble in reverse sequence **3...1**.
- Check complete unit for proper function.

A 04.10.1

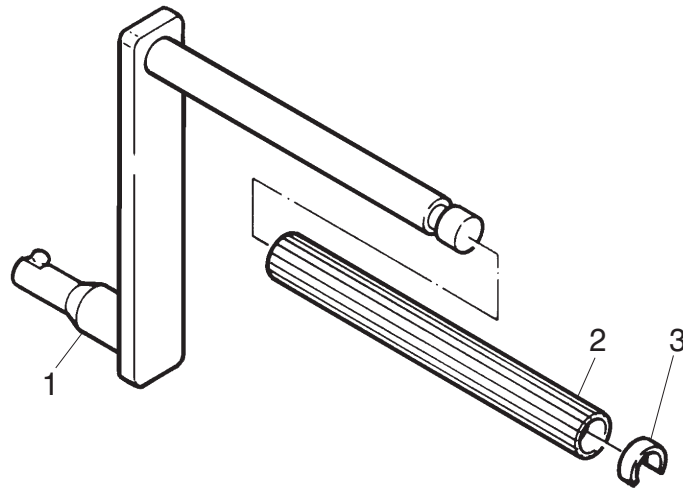

A 04.10.2

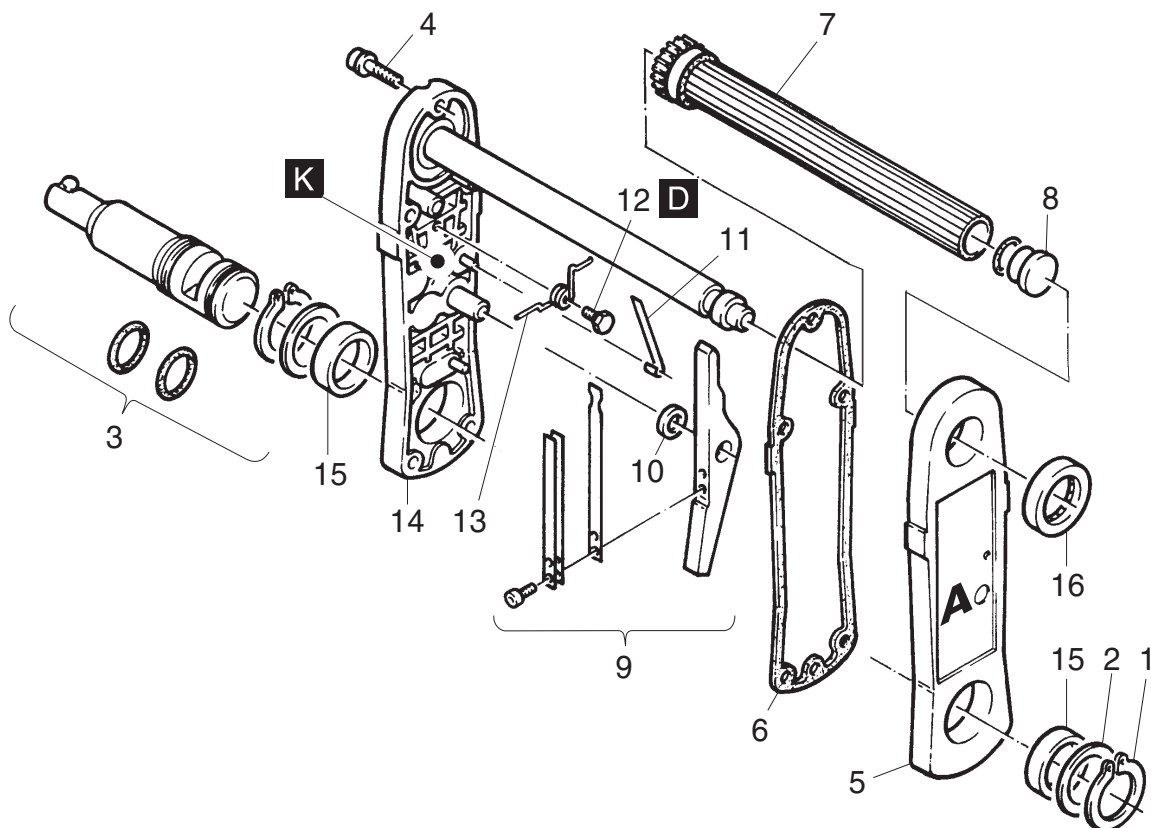

A 04.00 Start mechanical / pneumatic

A 04.11 Starting handle supports



General:

Version A 04.11.1

Part without replaceable bushing.

Version A 04.11.2

Part with replaceable bushing.

ATTENTION !

Take care, a worn guiding shell can cause serious injuries.

Preparations: –

Dismantling:

– Remove in numerical sequence 1...3/4.

NOTE:

Engines working under extremely dusty conditions should be equipped with a protection plate 4 which avoids access of dust to the contact area of camshaft seal ring.

Inspection / repair:

- Visual inspection.
- Check bore for wear and/or any other damage.

Version A 04.11.1

– In case bore is worn (oval) replace guiding shell.

Version A 04.11.2

– In case bore/bushing is worn (oval) replace guiding bushing 5.

Assembly:

- Assemble in reverse sequence 4/3...1.
Apply locking agent as specified!
Use starting handle to align guiding shell before tightening Allen screws.

A 04.12 Cranking claws

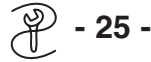

General:

Version A 04.12.1

Part is bonded into camshaft.

Version A 04.12.2

Parts fitted loose in camshaft.

ATTENTION !

Take care, a worn or damaged cranking claw can cause serious injuries.

Preparations:

– Remove guiding support if so fitted.

Dismantling:

Version A 04.12.1

– Weld (spots and arc-welding only) M8 nut onto crank jaw.

For removal of crank jaw use tool - 25 -
Protect area around camshaft to avoid any damage.

Version A 04.12.2

– Remove parts (pull) by hand in numerical sequence 1...3.

Inspection / repair:

- Visual inspection.
Replace crank jaw in case of wear.

Assembly:

Version A 04.12.1

– Apply high strength locking agent around location pin and insert (push) crank claw firmly in.

Version A 04.12.2

- Bring location groove in camshaft to TOP-position.
- Put location pin 3 onto crank jaw 2.
- Insert parts together into bore
- Place and tighten Allen screw 1.
Apply locking agent as specified!
- Assemble guiding support if so fitted.

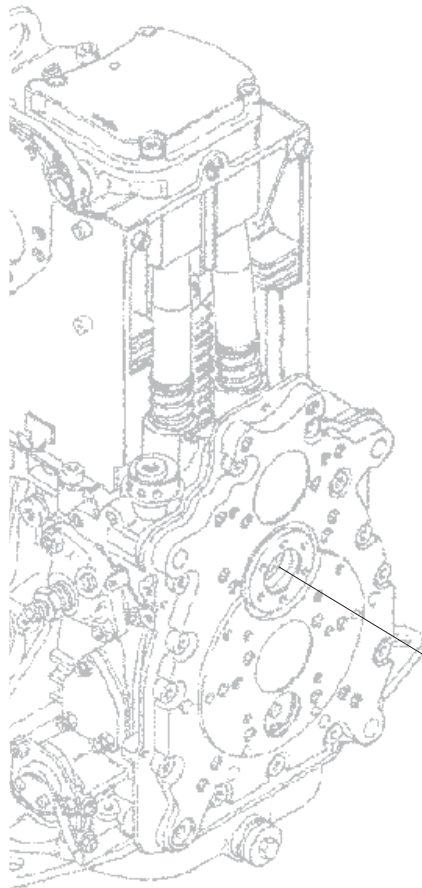

A 04.11.1

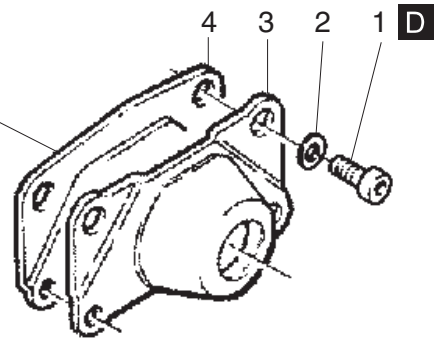

A 04.11.2

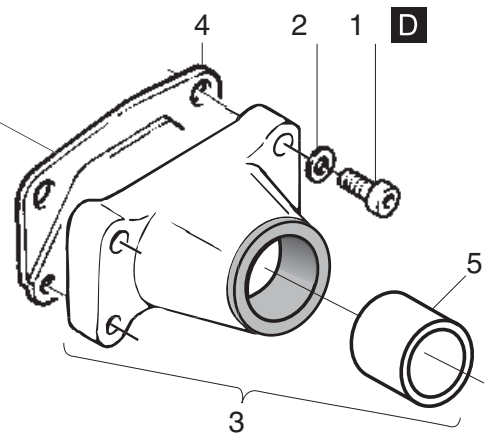

A 04.12.1

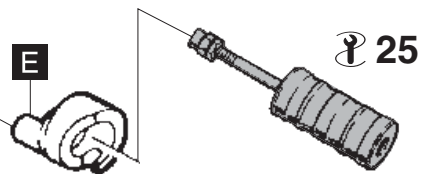

A 04.12.2

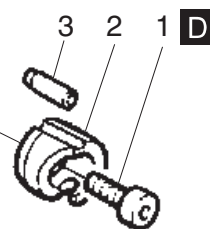

A 04.00 Start mechanical / pneumatic

A 04.30 Rope starts



General:

Recoil starters available respectively fitted as additional equipment in connections with engines as follows:

Engine types 1 D 30 - 31 - 35 - 40 - 41			
models	position	direction of rotation	execution of housing
S / Z	Flywheel side	counter clockwise	closed
T / U		clockwise	open

Preparations: –

Dismantling:

- Remove in numerical sequence **1...2** from respective engine flange.
- Pull knot / rope **3** with snipe nosed pliers from handle **4** and untie.
- Allow rope pulley **5** to retract slowly until recoil spring **6** is unwound.
Rope guide **13** and closing screw **14** may remain.
- Remove in numerical sequence **7...12**.
Brake spring **10** may remain.
- Remove rope pulley **5** carefully from recoil spring **6** respectively housing.

NOTE:

To prevent the recoil spring from uncoiling, rotate rope pulley back and forth to disengage inner spring eye and carefully lift out of housing.

Recoil spring needs not to be removed from housing, unless it is broken.

To remove recoil spring **6** take housing in both hands, open side down and hit housing on work bench or other flat surface.

Spring will drop out.

- Remove rope **3** from rope pulley **5**.

Inspection / repair:

- Visual inspection.
- Check all parts in question, inclusive driving elements **15** for wear and / or any other damage.

Assembly:

It is of utmost importance to follow the details as specified to obtain the correct assembly as far as engine models in connection with direction of rotation is concerned.

With unwound recoil spring out of housing:

- Wind recoil spring **6** into housing.

With new recoil spring - prewound:

- Place recoil spring in housing and push down into housing. Remove retaining wire.

NOTE:

The outer spring eye must be properly hooked around the retaining tab.

The clearance required between inner spring eye and rope pulley shaft has to be obtained as specified.

If necessary, rebend spring eye.

Apply high-temp. lub.-grease as specified over all mechanical parts during assembly.

- Slide rope **3** through hole in rope pulley **5** and wind rope around pulley according to engine model.

- Fit rope pulley together with rope **3** and carefully rotate it back and forth until it engages in the inner spring eye of the recoil spring **6**.

- Fit long end of torsion spring **12** into hole of rope pulley **5** as specified according to engine model, pushing it over pawl guide.

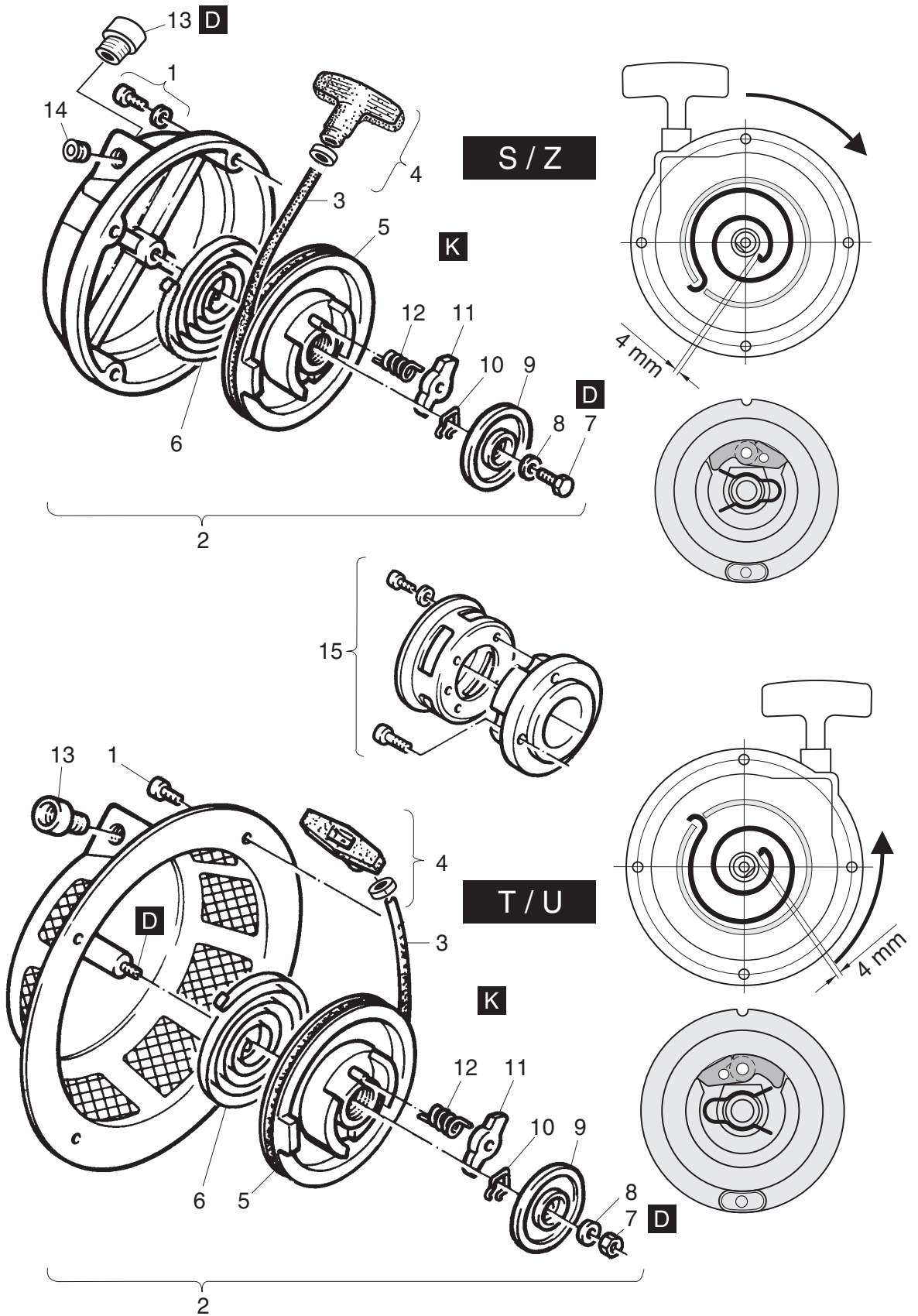

A 04.00 Start mechanical / pneumatic

A 04.30 Rope starts

- Slip pawl **11** according to engine model over pawl guide.
Short end of torsion spring **11** must fit into groove of pawl.
- Push down brake disk **9** with brake spring **10** as specified according to engine model onto rope pulley shaft.
- Place and tighten retaining items **8...7**.
Apply locking agent as specified !
- Rotate rope pulley **5** as specified 3 - 4 turns against the recoil spring tension and hold firm.
- Slide rope **3** through the rope guide **13** in the housing respectively through handle **4** and tie knot.
Slowly return handle.
- Check recoil starter for proper function.
If the recoil starter has been properly assembled, the pawl must move outward when rope is pulled.

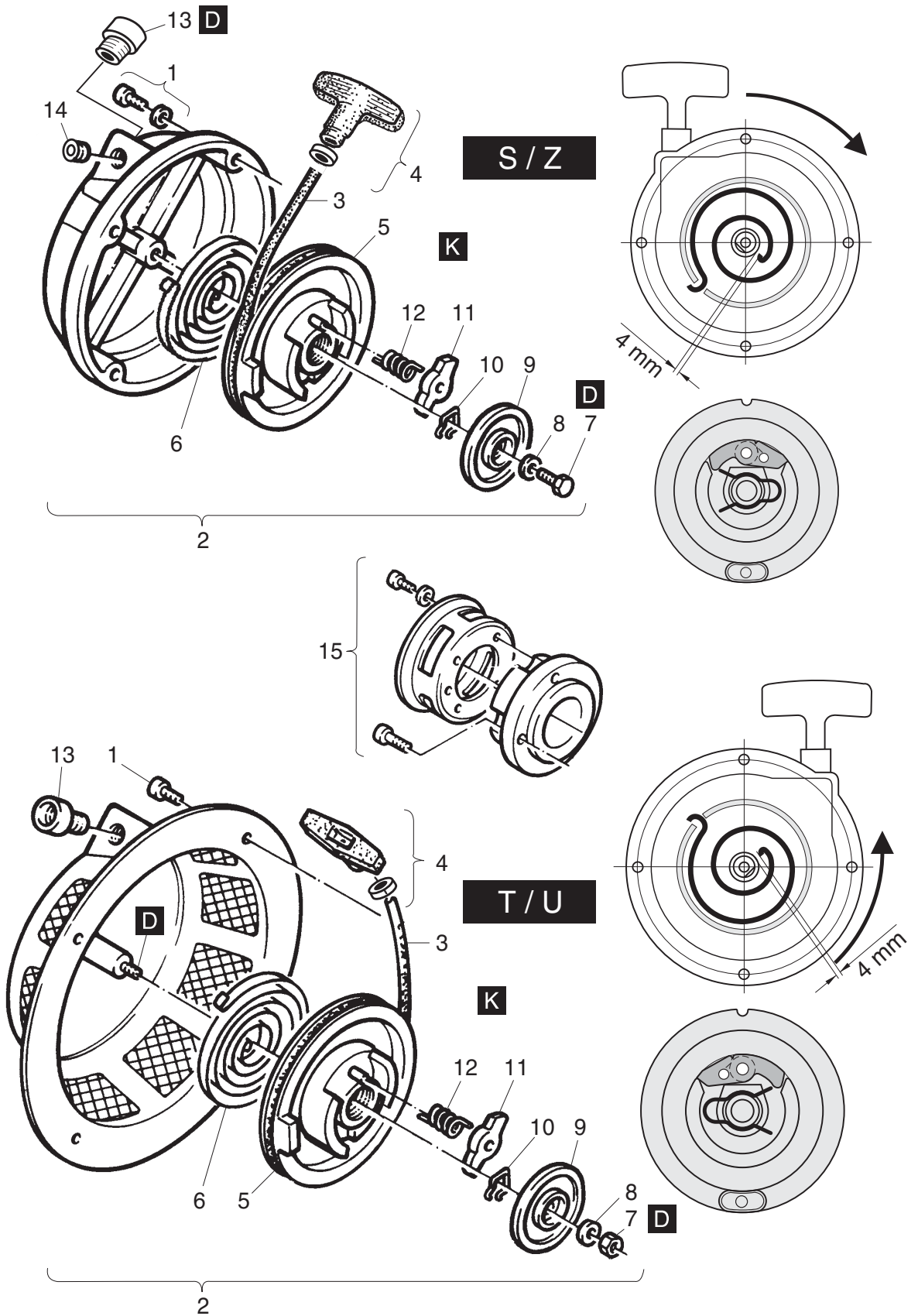

A 05.00 Start electrical

General:

The execution of electrical equipment depends on voltage (12 V or 24 V) as well as the direction of rotation.

Different ring gears, starter motors, coils and magnet segments are applied.

A 05.00 Start electrical

A 05.20 Starter motors

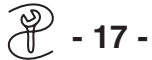

General:

Starter motors are different in construction as well as voltage and direction of rotation is concerned.

It is of utmost importance not to combine parts from different construction or version.

Preparations:

- Disconnect battery in sequence - / +
- Disconnect cable connections as necessary, respectively remove retaining plate with voltage regulator depending on kind of equipment.

Dismantling:

- Remove in numerical sequence **1...6**.
Studs **7** may remain.
For removal use tool - **17** -

Inspection / repairs:

- Visual inspection.
- Check bushing and pinion for wear and/or any other damage.
- Check pinion for free movement on shaft.

NOTE:

Repairs or adjustments in connection with the starter motor should be carried out by a HATZ-Distributor or any other authorized workshop.

Assembly:

- Assemble in reverse sequence **6...1**.
- Reassemble respectively reconnect electrical system as dismantled before.
- Reconnect battery in sequence **+/-**
- Check (start) electrical system for proper function.

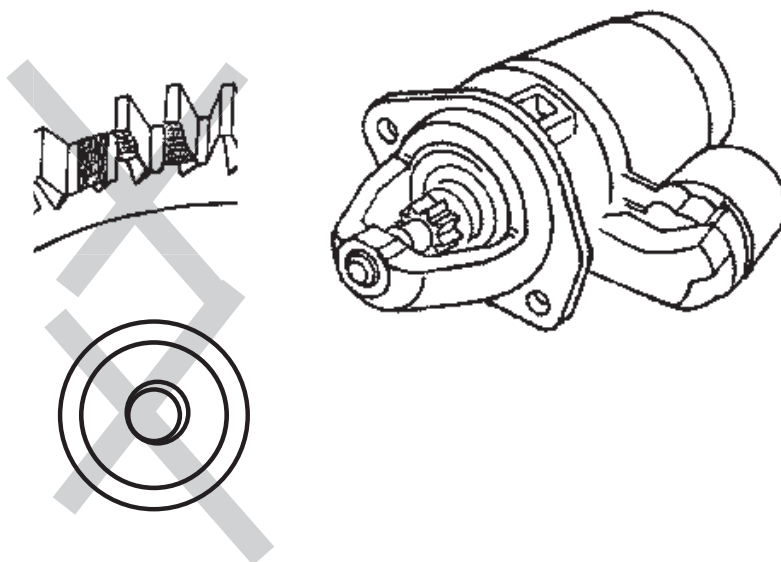
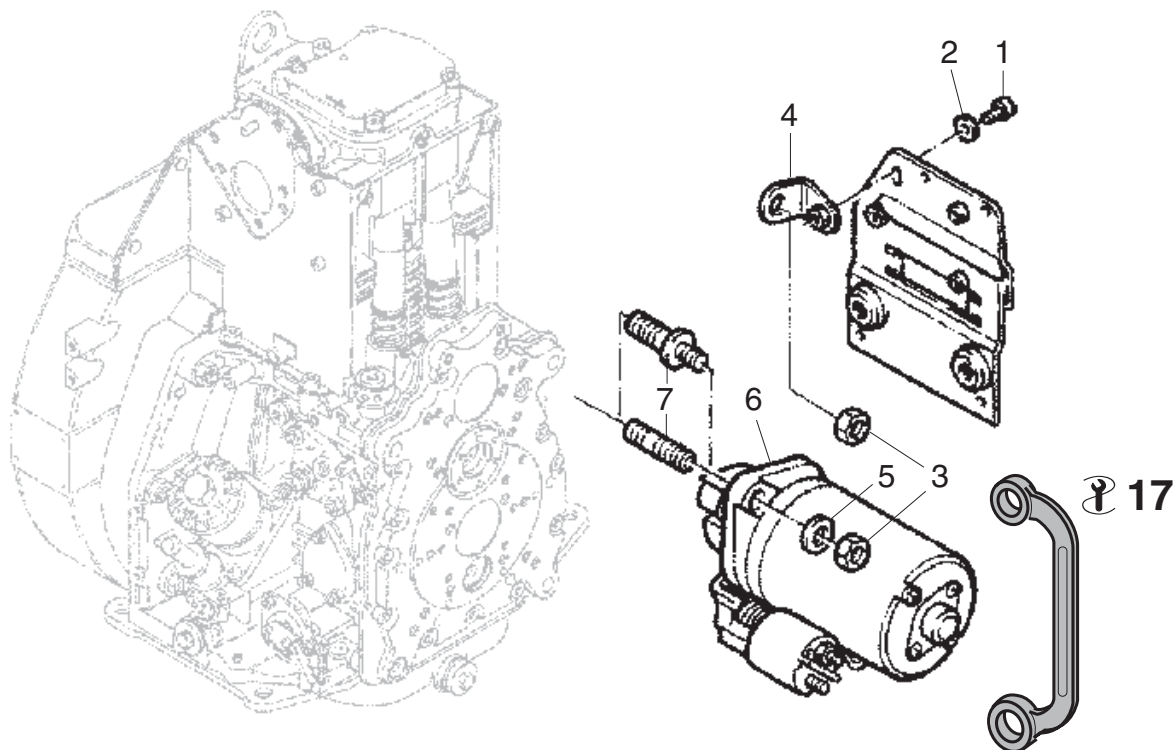

A 05.00 Start electrical

A 05.40 Alternator / Magnet segments



General:

It is recommended to always check the alternator for degree of function before any disassembly.

Ref.: Section 4

Preparations:

– Remove flywheel (M 17.00).

Version A 05.40.1

The magnet segments are located on the flywheel by means of centering/roll pins.

Version A 05.40.2

The magnet segments are located on the flywheel by means of a machined location ring groove.

Version A 05.40.3

The magnet segments are substituted by a magnet ring.

Dismantling:

– Remove in numerical sequence

Inspection / repair:

– Check magnet segments for wear or any other damage.

Assembly:

– Assemble in reverse sequence
Torque to specification!

A 05.40.1

A 05.40.2

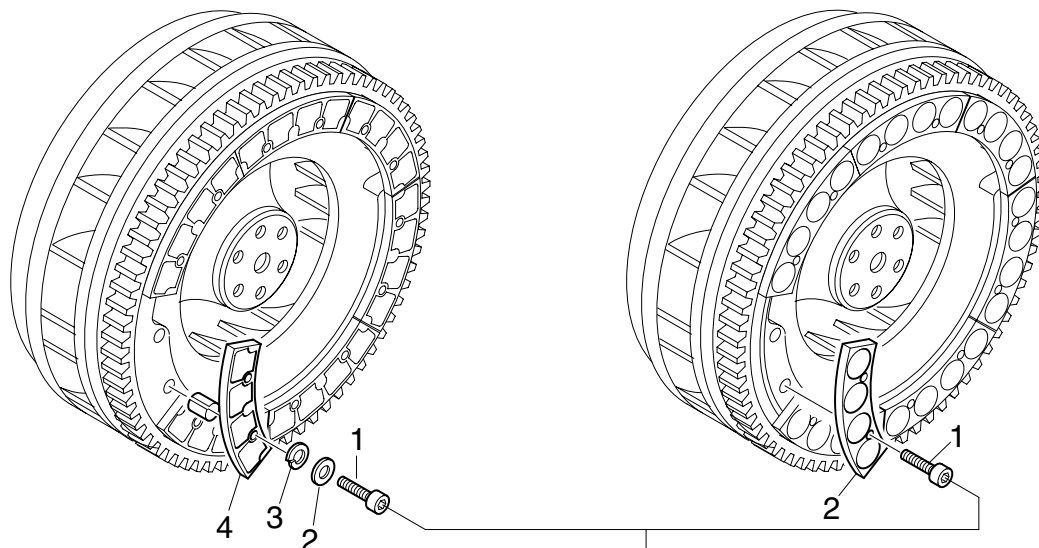

2.8 Nm
2.1 lb ft

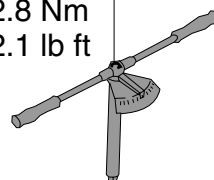

A 05.40.3

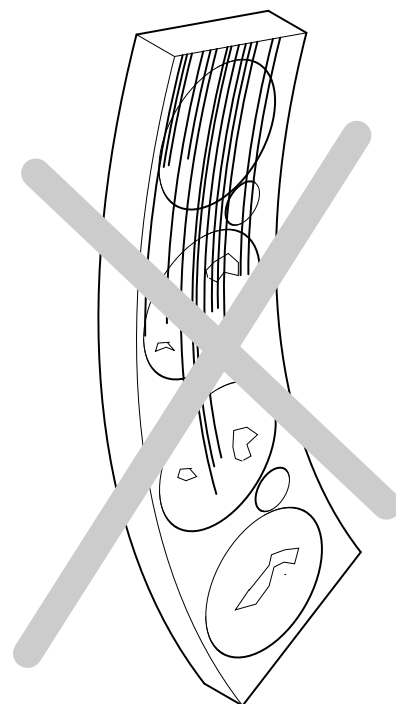
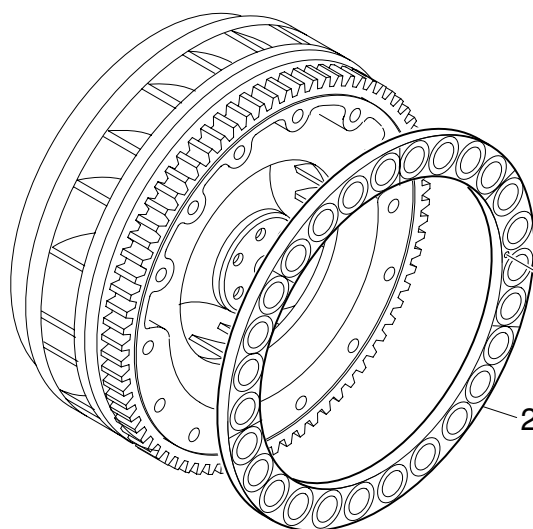

A 05.00 Start electrical

A 05.41 Alternator / Coils



Version A 05.41.1

Open coils fixed to the crankcase.
Fixation and adjustment of air gap is done by spacers.

Preparations:

- Remove flywheel and housing.

Dismantling:

- Disconnect electrical system.
- Remove in numerical sequence **1...5**.

Inspection / repair:

- Visual inspection.
- Check coils for wear and/or any other damage.

Assembly:

- Assemble in reverse sequence **4...1**.
Without spacers **5** and retaining nuts **1** loose.

Adjustment:

- Assemble flywheel.

NOTE:

- Flywheel tight, not torqued.
- Push flywheel towards governor side or even better put engine onto flywheel to eliminate the end float.
 - Measure gap between coils and magnet segments.
Use feeler gauge.
 - Keep spacers as required next to the corresponding coil to obtain air gap as specified.
 - Remove flywheel.
 - Place spacers as required between crankcase and corresponding coils.
 - Tighten Hex.-nuts uniformly.
 - Finish assembling.

A 05.41.1

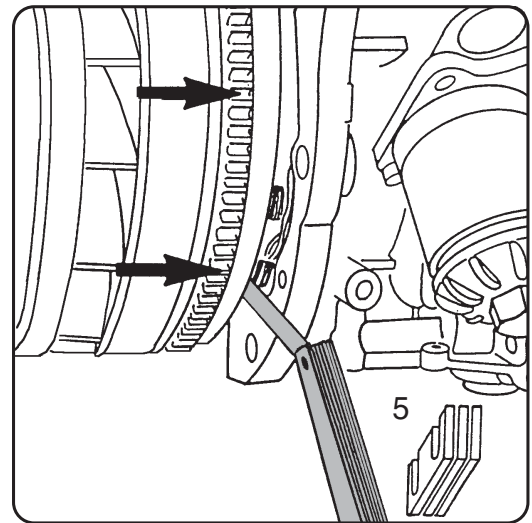
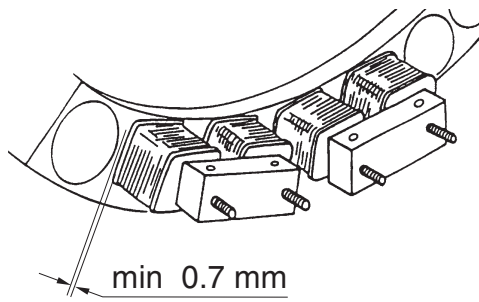
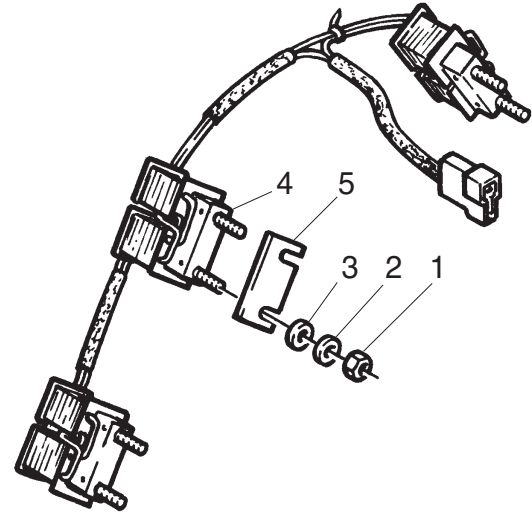
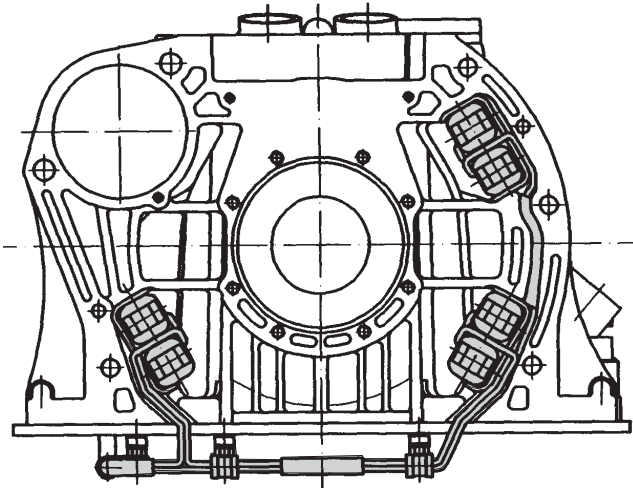

A 05.00 Start electrical

A 05.41 Alternator / Coils



Version A 05.41.2 (1D 60-80)

Coils fitted to support and fixed on bottom side of crankcase.

Fixation and adjustment of air gap by moving the complete unit in longitudinal slots.

Preparations:

- Remove flywheel and housing.

Dismantling:

- Disconnect electrical system.
- Remove in numerical sequence **1...4**.
If necessary separate coils and support.

Inspection / repair:

- Visual inspection.
- Check coils for wear and/or any other damage.

Assembly:

- Assemble in reverse sequence **4...1**.

NOTE:

Push unit **3** as far as possible in direction to crankcase and tighten Hex.-nuts **1** temporarily.

Adjustment:

- Assemble flywheel.
- Put engine onto flywheel to eliminate the end float.
- Place feeler gauges between coils and flywheel-magnet segments to obtain air gap as specified.
- Release retaining nuts **1**.
Allow complete unit **3** to drop down onto feeler gauges.
- Tighten Hex.-nuts uniformly.
- Finish assembling.

A 05.41.2

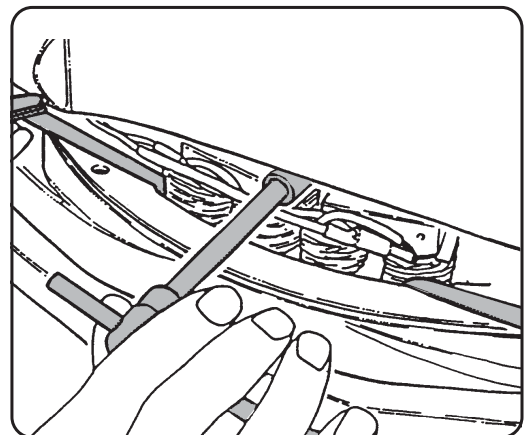
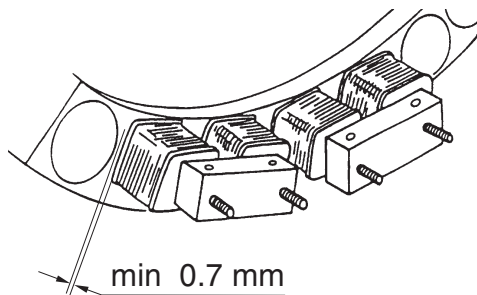
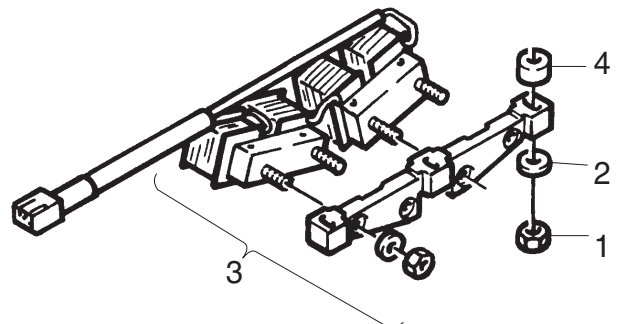
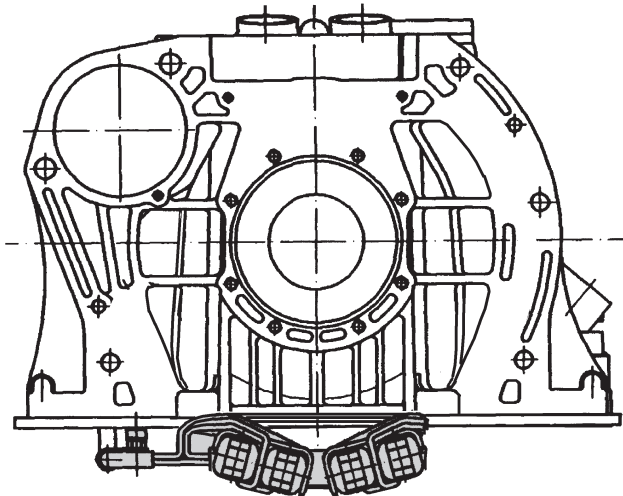

A 05.00 Start electrical

A 05.41 Alternator / Coils



Version A 05.41.3

Coil encapsulated and fitted to crankcase. Fixation and adjustment of air gap by moving the coil in longitudinal slots.

Preparations:

- Remove flywheel.
1 D 30 - 31 - 35 - 40 - 41 - 50 only !
- Remove protection guard **1**.

Dismantling:

- Disconnect electrical system.
- Remove in numerical sequence **2...4**.

Inspection / repair:

- Visual inspection.
- Check coil for wear and/or any other damage.

Assembly:

- Assemble in reverse sequence **4...2**.
- Push coil **4** as far as possible in direction to crankcase and tighten Allen screws temporarily.

Adjustment:

- Assemble flywheel.
1 D 30 - 31 - 35 - 40 - 41 - 50 only !
- Push flywheel towards crankcase.
Ensure flywheel remains in position !
- Remove grub screw or plug **5**.
- Place feeler gauge between coil and flywheel-magnet segments to obtain air gap as specified.
- Release Allen screws **2**.

- Push coil towards flywheel against feeler gauge.
Ensure flywheel remains in position !
- Tighten Allen screws uniformly.
- Reassemble protection guard **1** and grub screw or plug **5**.
- Reconnect electrical system.

Alternator 12 V “high output” 350 W (1D60 ... 90):

On this alternator the gap between the coil and the magnet ring must be adjusted to **1.2 mm** . Otherwise the max current of 25 A will be exceeded and the voltage regulator switch could be damaged.

A 05.41.3

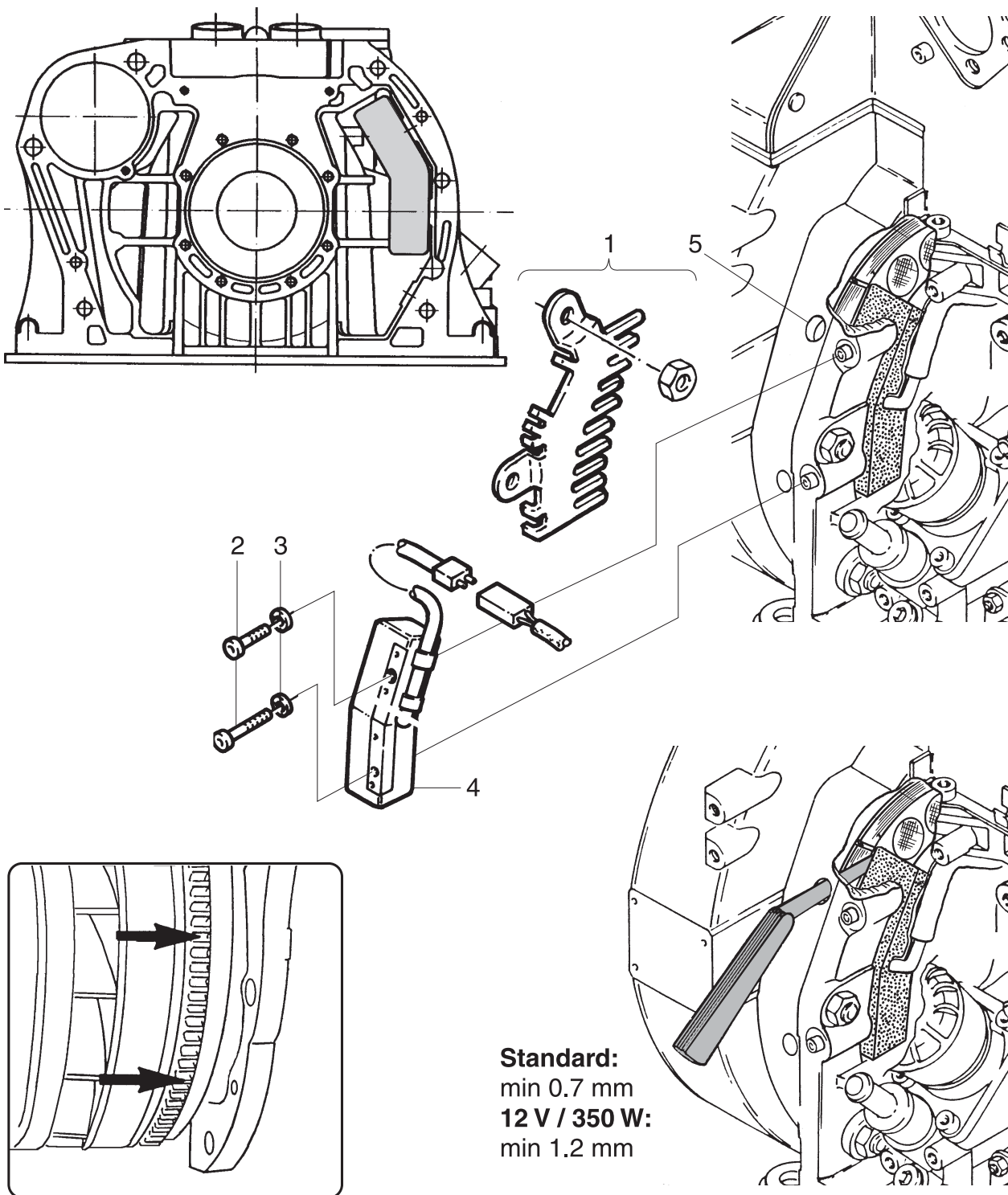

Standard:
min 0.7 mm
12 V / 350 W:
min 1.2 mm

A 05.00 Start electrical

A 05.80 Ring gears



General:

Ring gears are different in pitch as well as direction of rotation is concerned.

It is of utmost importance not to combine parts with incorrect pitch or rotation.

Preparations:

- Remove flywheel (M 17.00).

Inspection / repair:

- Check part for broken teeth and/or other damage.
Burr's can be filed down to a certain extent.

Dismantling:

- Check condition of ring gear before removal.
In case ring gear has to be removed proceed as follows:
 - Heat starter ring gear rapidly (gas torch) and detach ring from flywheel.
Another way is to drill and chisel the ring gear open.

Assembly:

- Heat ring gear properly around its diameter and shrink fit ring gear onto flywheel.

NOTE:

Take care for correct position of chamfered side facing towards starter motor and proper seat on flywheel.

- Finish assembling.

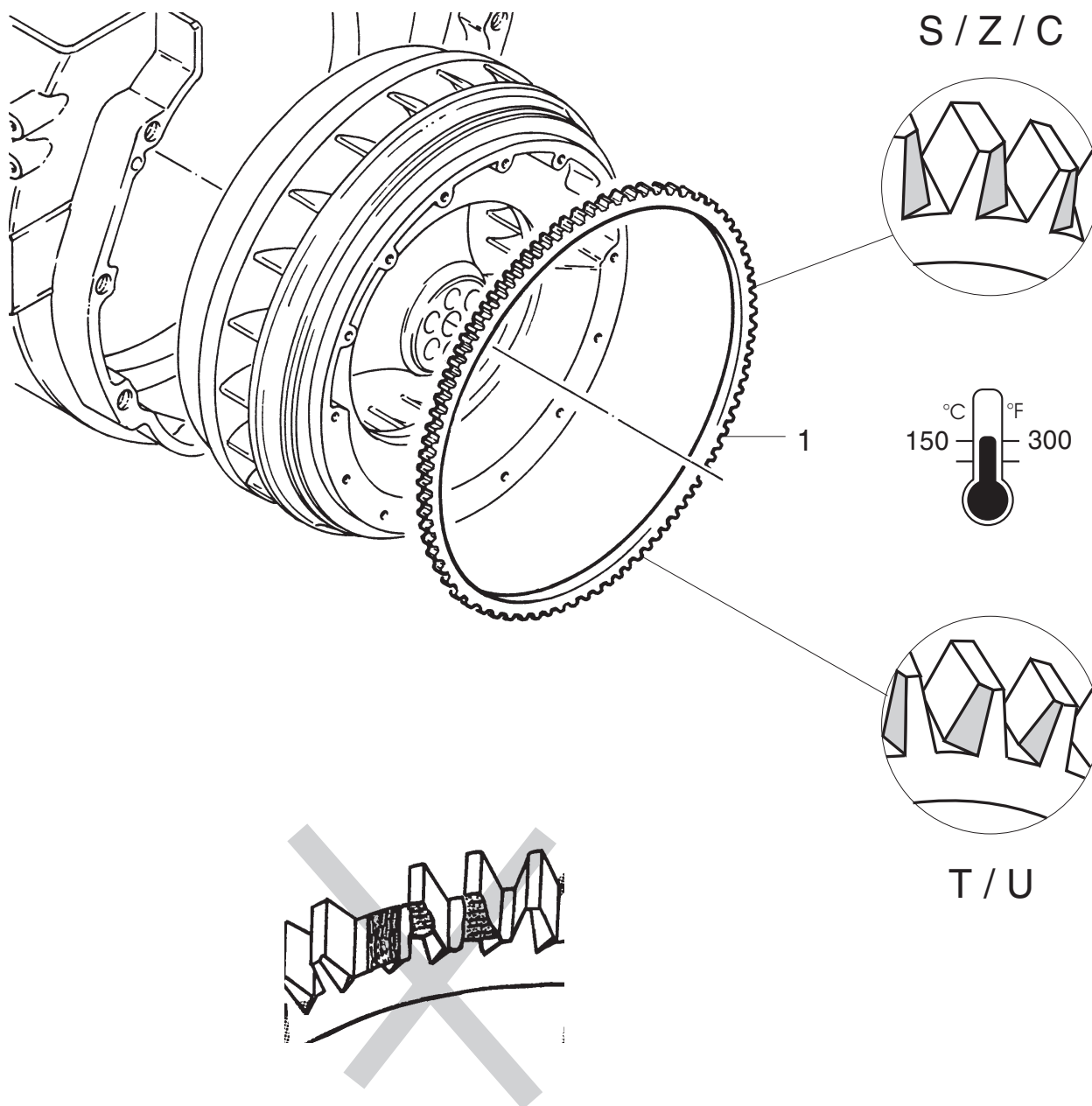

A 07.00 Lubrication oil

A 07.20 Lub.-oil filters, strainers



General:

Retro-fit of lub.-oil filter is possible at any time and requires removing of closing cover only.

Version A 07.20.1

Version A 07.20.2

Preparations: –

Dismantling:

– Remove in numerical sequence **1...6**.

Version A 07.20.2:

Spring in filter housing **5** remains.

Inspection / repair:

- Visual inspection.
- Check oil filter element **2** and rectangular rings **6**.

Maintenance according to instruction book.

Assembly:

- Assemble in reverse sequence **6...1**.
Apply High-temp. lub. -grease as specified!
- Ensure rectangular ring **6** at bottom side remains in position during assembly.
- Place and tighten Allen screws crosswise and uniformly.

A 07.20.1

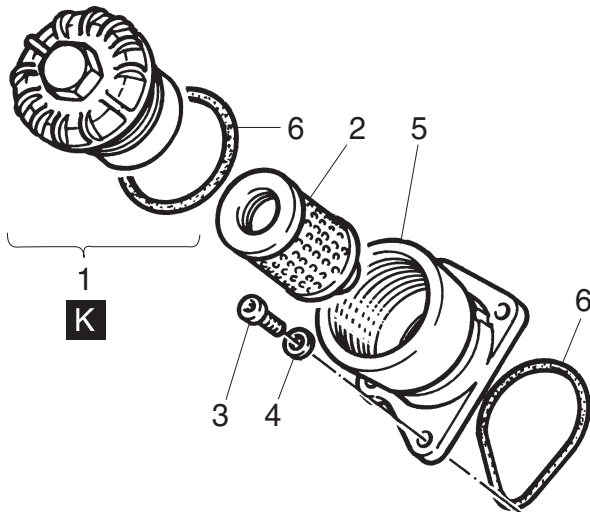

A 07.20.2

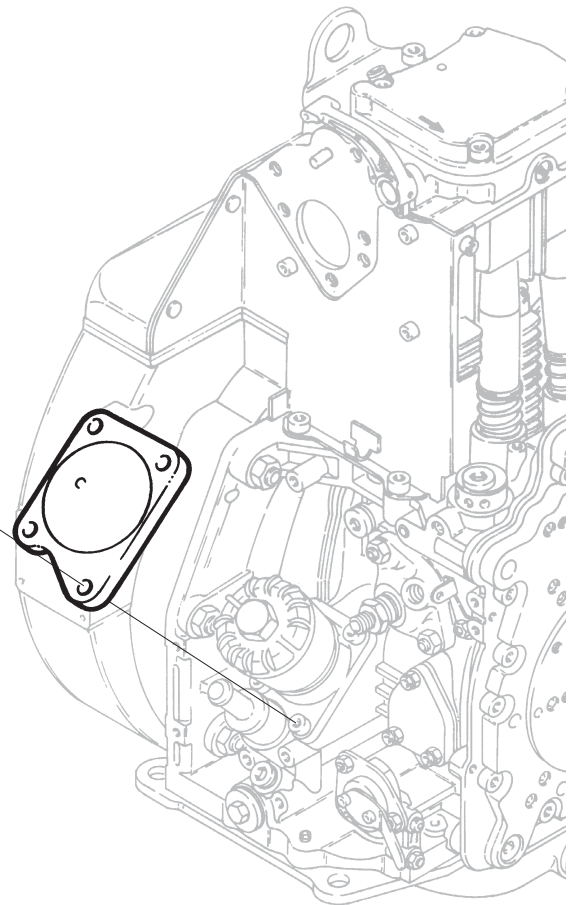
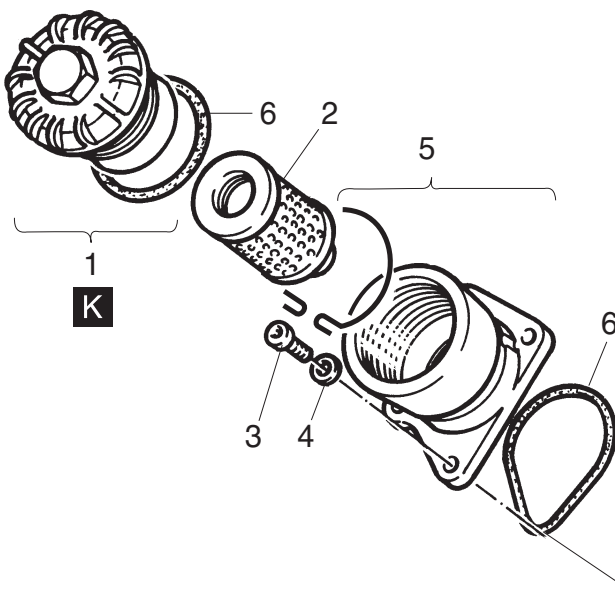

A 07.00 Lubrication oil

A 07.30 Oil sumps



General:

Additional oil sump may be used to obtain higher oil change intervals.

Depending on the oil quantity as required

- different oil pans
- suction strainers and adaptors
- spacer rings for the oil pan
- dipsticks of different length may be fitted.

Take care not to interchange these components by mistake during a repair and / or conversion job.

Assembly:

Ref.: Chapt. M 01.30

In addition two of spring washers and elastic washers are fitted between suction sieve and oil intake tube.

Apply sealing agent as specified !

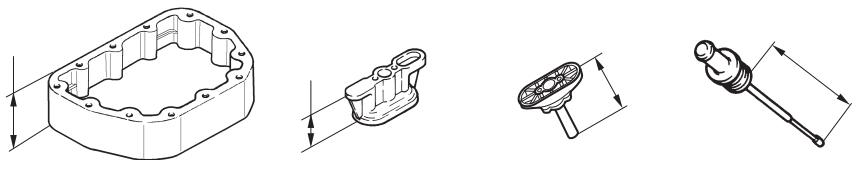
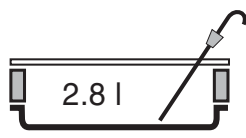
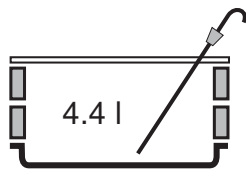
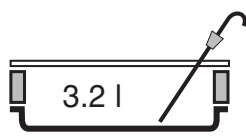
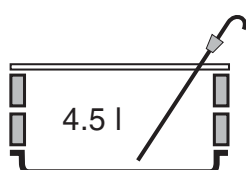
				
1D30-31-35-40-41	mm	mm	mm	mm
	60	25	58	204
	60 + 60	25	118	285
1D60-80-81	mm	mm	mm	mm
	40	25	58	204
	40 + 40	25	98	225

A 09.00 Speed controls

A 09.60 Low idle speed stabilization

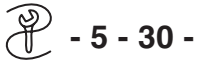

General:

Several engine applications require a very precise speed governing also in the range of low idle, for example engines with hydraulic pumps in cold condition.

For this case the low idle speed stabilization is available.

Function:

- The main governor spring is approx. 1 mm shorter than the standard one so that it is deactivated at engine speeds below 1000 rpm.
- Governor lever **1** is working over the full speed range.
- The retainer spring **2** is connected to an adjustable lever **3** and works as governor spring at the speed range below 1000 rpm.
- The stabilization spring **4** is fitted to stabilize the overreaction of the governor lever when the speed control lever is turned back into „low“ position.
It can be adjusted by the eccentric disk **5**.
- The standard stop screw **6** is turned back a few threads to ensure it is out of function.

Basic adjustment:

- Turn screw **II** so that eccentric disc **5** is facing towards timing cover.
Flat surface at outer end of screw **II** is now parallel with timing cover.
- Turn screw **III** into a position that the stabilization spring **4** is slightly touching the eccentric disc **5**.
This is the final position.
Lock screw **III** by tightening the counter nut.
- Turn screw **II** approx. 180° counter clockwise (Stabilization spring **4** now is forced as far as possible towards crankcase).

- Turn screw **I** so that lever **3** is facing vertical downwards (pin **7** is also in a vertical position).

Fine tuning:

(with engine running)

- Connect rev. counter - **30** -
- Set low idle speed to approx. 600 rpm.
If engine speed drops too far and engine stops, than turn screw **I** in direction „+“ (counter clockwise).
If such low speed can not be obtained turn screw **I** in direction „-“ (clockwise) or turn screw **6** back for some threads.
- Turn screw **I** slightly in counter clockwise direction until the aspired speed is reached and lock screw with counter nut.
- Turn screw **II** clockwise (use tool - **5** -) until the stabilizing spring is just touching the governor lever. This is indicated by an additional rise of the engine speed (max. 5 rpm).
Lock screw by tightening the counter nut.
- Finally seal all adjustment screws with sealing wax.

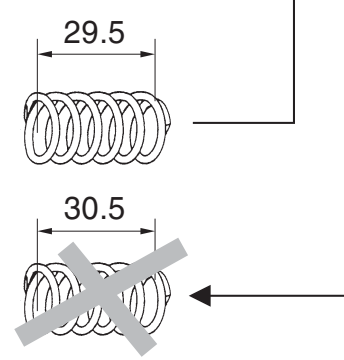
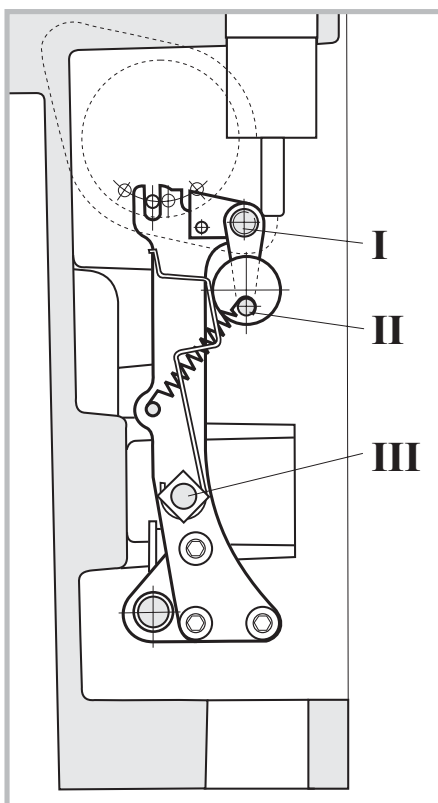
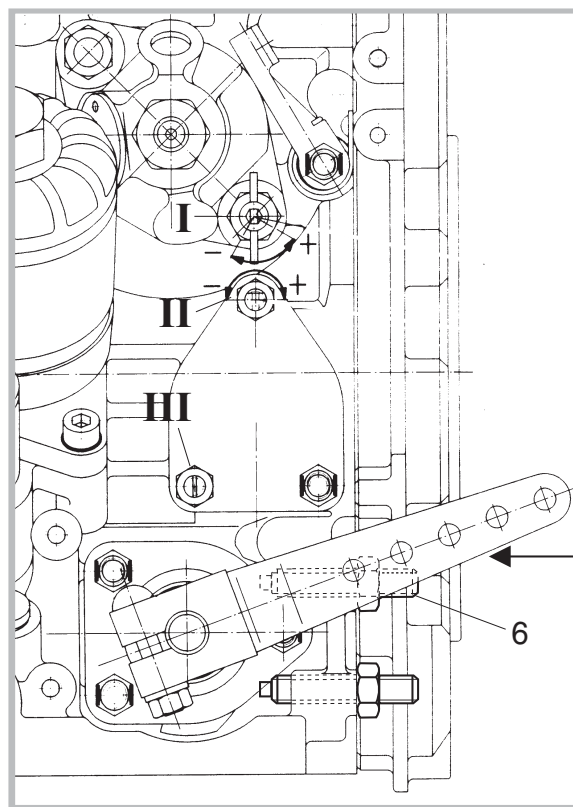
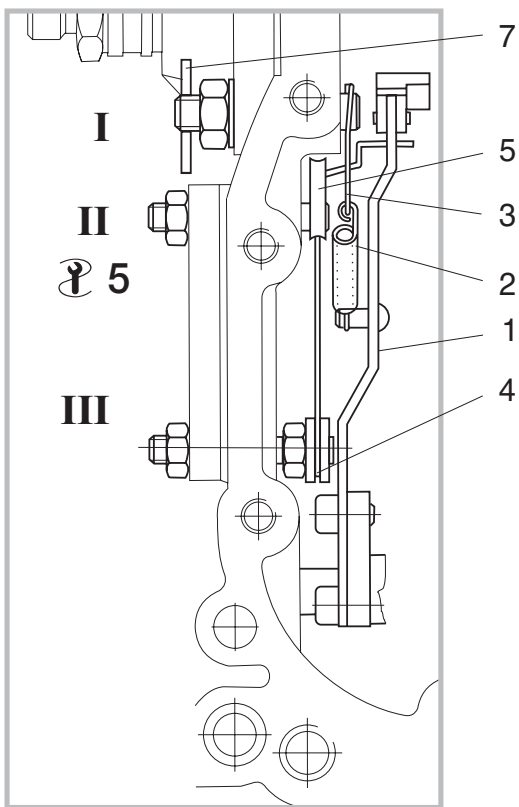

A 11.00 Remote engine controls

A 11.10 Stop devices



Version A 11.10.1

Stop lever **S/Z/T/U**

Preparations: –

Dismantling:

- Remove in numerical sequence **1...4**.
- Remove timing cover (M 11.00).
- Remove lever **5**.

Bushing **6** may remain

Inspection / repair:

- Check lever **5** and bushing **6** for wear or any other damage.

Assembly:

- Press bushing **6** firmly in (if necessary).
Apply high strength locking agent as specified !
- Bring bushing **6** to a position to have the lever **5** just in the centre of the respective contact face of the governor lever.
- Assemble in reverse sequence **5...1**.

NOTE:

Hold stop lever **3** against tightening force of Hex.-nut **1** to avoid excessive stress on governor lever.

- Finish assembling.

Version A 11.10.2

Stop lever **C**.

Preparations: –

Dismantling:

- Remove in numerical sequence **1...10**.
For further repair remove capsule parts as required to have access to standard engine respectively to bush **11** and lever **12**.

Inspection / Repair:

- Check lever **5** and bushing **6** for wear or any other damage.

Assembly:

- Assemble in reverse sequence.

NOTE:

Hold lever **9** against tightening force of shaft **8** to avoid excessive stress on governor lever.

Hold lever **3** against tightening force of Hex.-nut **1** to avoid excessive stress on linkage and/or governor lever.

A 11.10.1

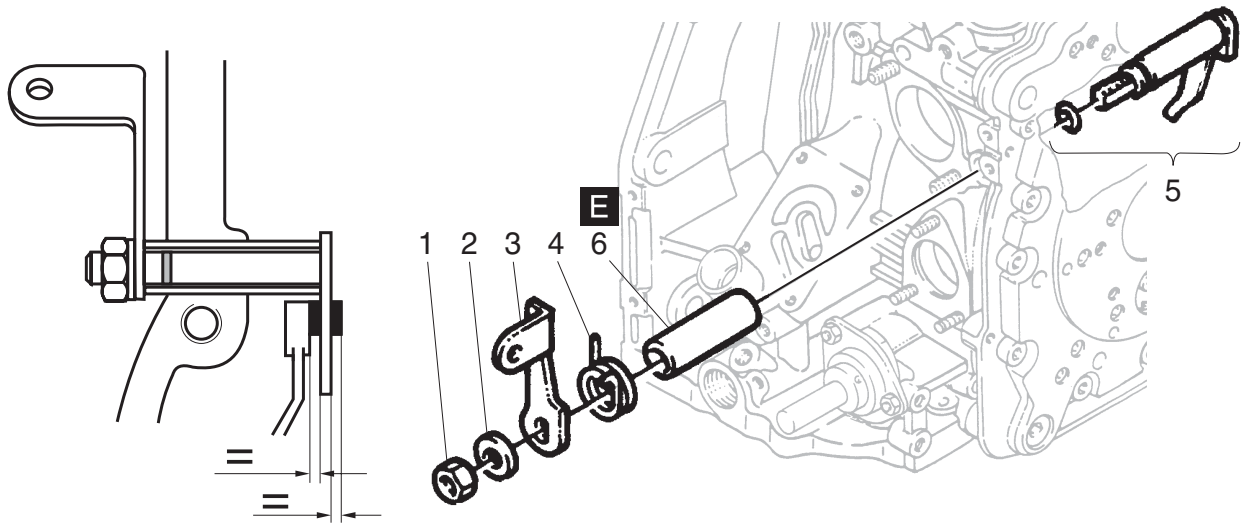

A 11.10.2

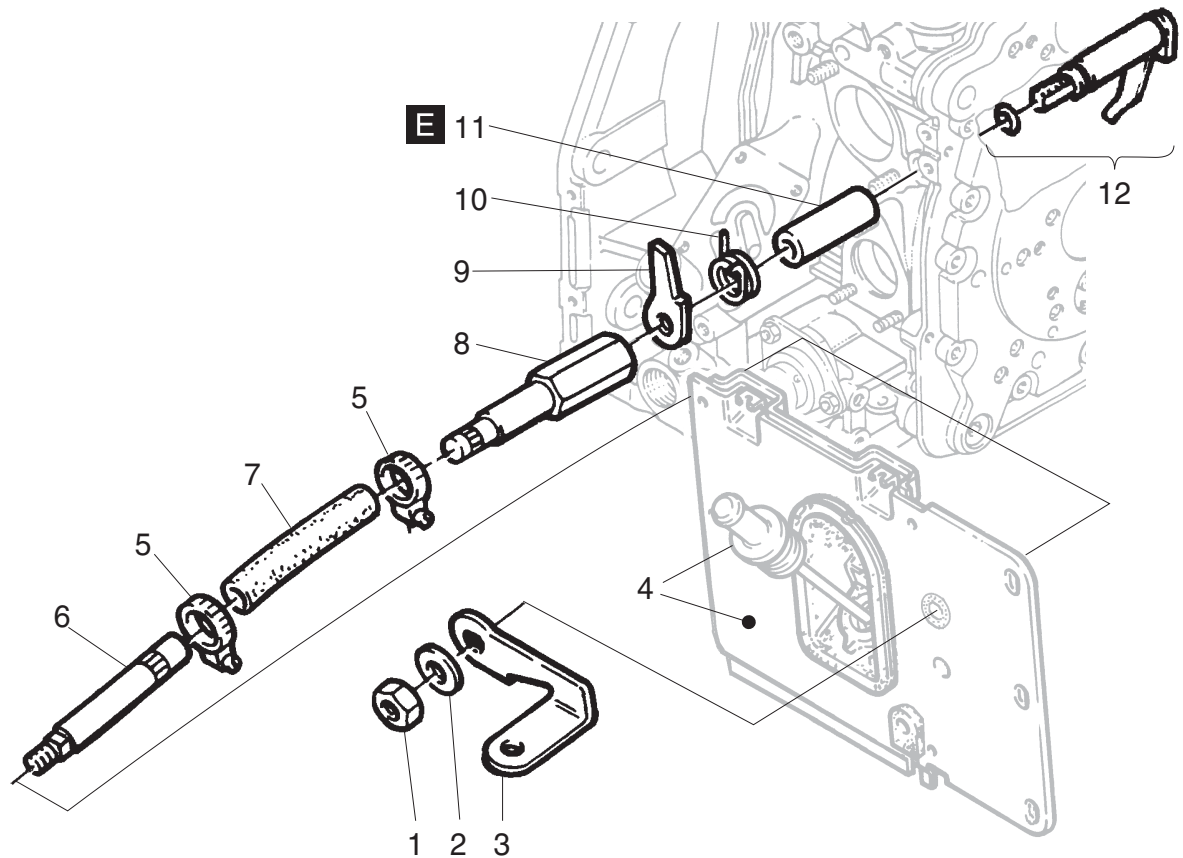

A 11.00 Remote engine controls

A 11.30 Auto. Shut-off device



General:

In order to avoid serious engine damage due to insufficient lubrication (e.g. excess tilting of engine), the mechanical shut-off device was developed.

Function:

If the oil-pressure is too low, the fuel feed and fuel return is shut off by a valve.

- Opening pressure on cold engine 0.4 bar
- Shut-off reaction pressure approximately 1.0 bar at 3000 rpm
- Idle speed of 800 rpm admissible up to oil level "min".
- Once fuel system has run totally dry, relief lever must be activated for approx. 15 seconds for bleeding after tank filling.

In case of (repair) work at the shut-off device, the correct connection of fuel pipes (flow direction) must be assured.

- 1 = inlet from fuel filter (tank)
- 2 = inlet to injection pump
- 3 = return from injection pump
- 4 = return to tank

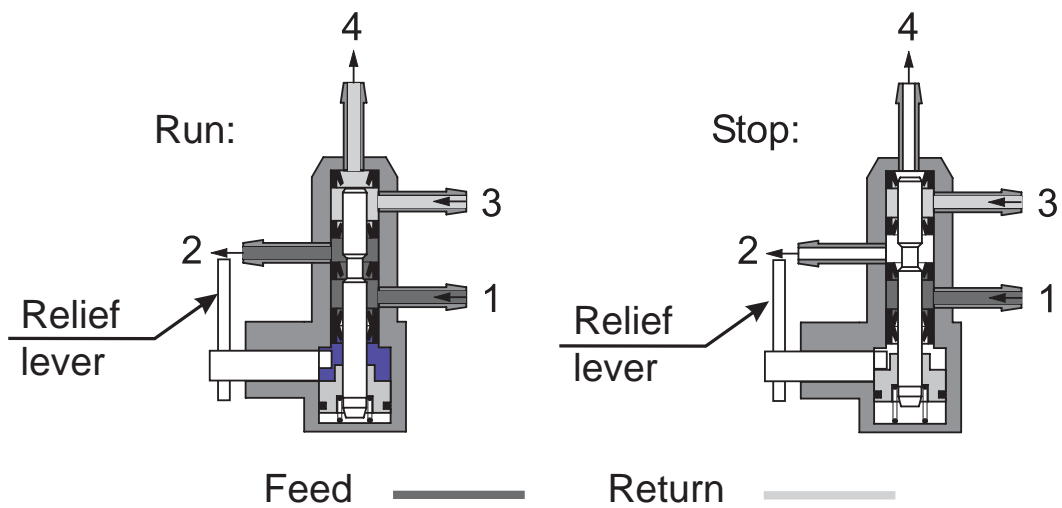
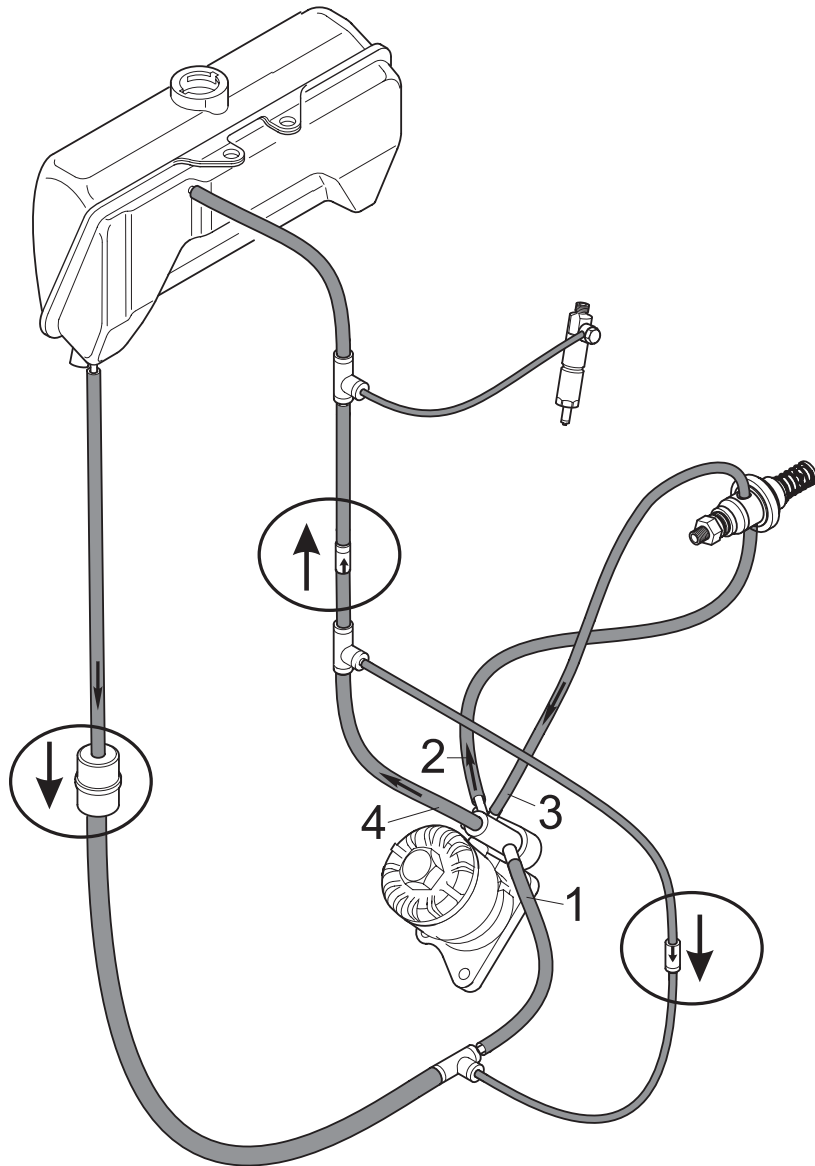

A 15.00 Housings - flanges - adaptors

A 15.20 Adaptor housings



Preparations:

- Remove starter motor if so fitted.

Dismantling:

- Remove in numerical sequence **1...7** depending on kind of application.
Parting sheet **9** may remain.

NOTE:

Removal of parting sheet requires dismantling of flywheel **8**.

Inspection / repair:

- Visual inspection.
- Check housing for cracks or any other damage.

Assembly:

- Assemble in reverse sequence **9...1**.
- Assemble starter motor if so fitted.

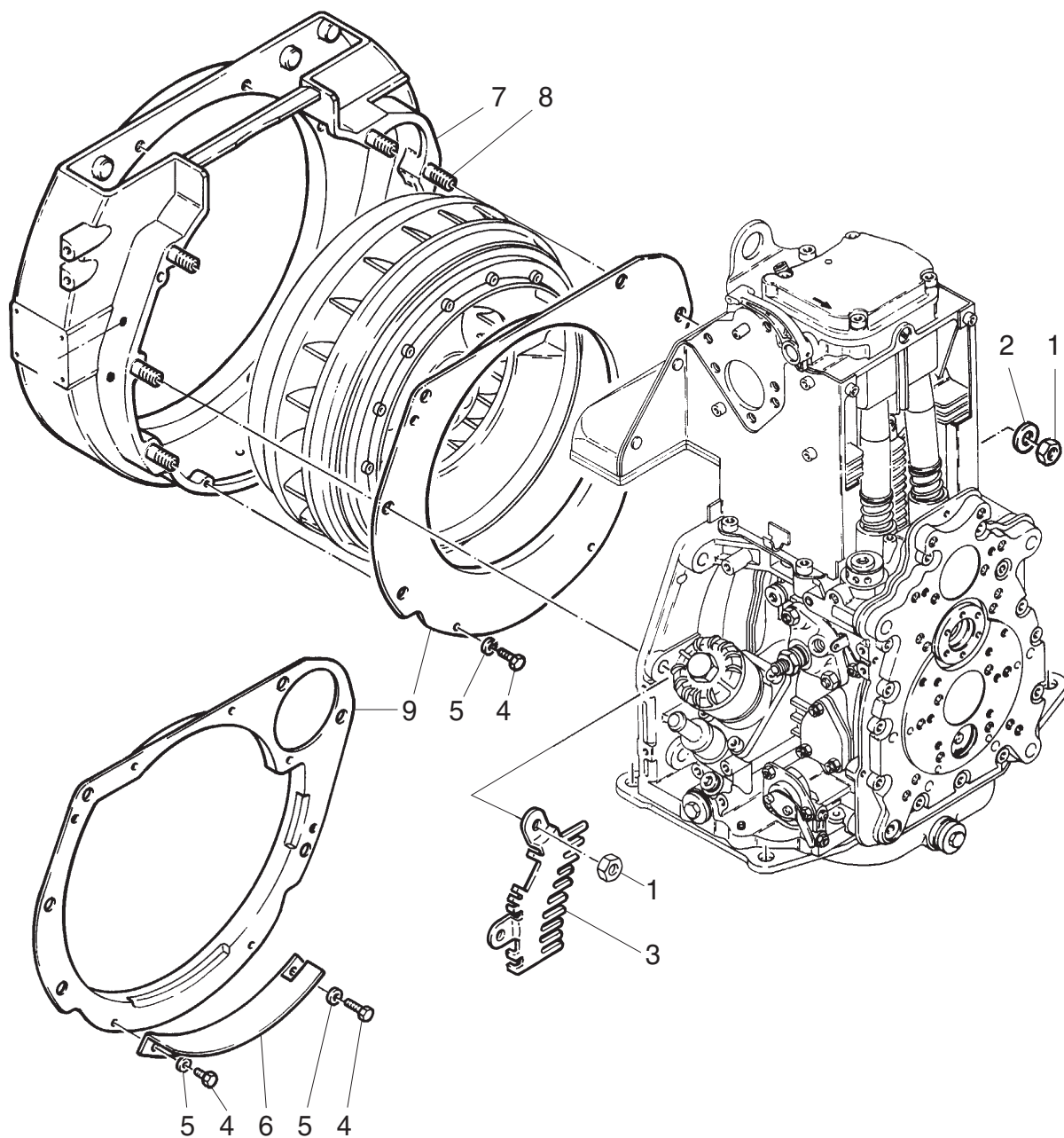

3. Basic engine

M - Basic engine

M-Disassembly cross reference scheme

When dismantling . . . ○	Preparations to be made X																													
	Capsule	Timing cover	Oil sump	Speed control	Breather system	Flywheel	Fuel pressure pipe	Cowling / air duct	Injection pump	Injector	Extra fuel device	Governor	Oil pump	Cover for cylinder head	Pushrod and protection tubes	Cylinder head	Cylinder	Piston	Conrod	Camshaft	Roller tappet	Cam followers	Bearing flange	Crankshaft gearwheel	Crankshaft-thrust plate	Crankshaft	Balancer unit	Base plate	Crankcase	
Capsule	○																													
Timing cover	X	○																												
Oil sump	X		○																											
Speed control	X	X		○																										
Breather system	X				○																									
Flywheel	X					○																								
Fuel pressure pipe	X						X	○																						
Cowling / air duct	X				X	X	X	○																						
Injection pump	X						X		○																					
Injector	X						X			○																				
Extra fuel device	X				X		X	X			○																			
Governor	X	X										○																		
Oil pump	X	X										X	○																	
Cover for cylinder head	X													○																
Pushrod and protection tubes	X													X	○															
Cylinder head	X				X		X	X						X		○														
Cylinder	X				X		X	X						X	X	X	○													
Piston	X				X		X	X						X	X	X	X	○												
Conrod	X		X		X		X	X						X	X	X	X	X	○											
Camshaft	X	X					X	X						X	X							○								
Roller tappet	X	X					X	X						X	X							X	○							
Cam followers	X	X					X	X						X	X							X		○						
Bearing flange	X					X								X		X								○						
Crankshaft gearwheel	X	X				X	X							X	X							X			○					
Crankshaft-thrust plate	X	X				X	X							X	X							X			X	○				
Crankshaft	X	X	X		X	X	X	X	X					X	X	X	X	X	X	X	X	X	X		X	X		○		
Balancer unit	X	X	X		X	X	X	X	X					X	X	X	X	X	X	X	X			X	X		X	○		
Base plate	X		X																											○
Crankcase	X	X	X	X	X	X	X	X	X		X			X	X	X	X	X	X	X	X	X	X	X	X	X	X	X	X	○

M 01.00 Crankcase

M 01.10 Crankcase, nozzle and bearings



Preparations:

Ref.: M-Disassembly cross reference scheme.

Oil spray nozzle

– Install and screw nozzle **3** firmly in place so oil spray will be directed down directly on the camshaft.

Apply high strength locking agent **E**.
Clock-wise engines (version T/U) are equipped with an additional oil spray nozzle in the timing cover. It points to the middle of the camshaft bearing bore (view to inside of timing cover).

Main bearing

Dismantling:

- Check main bearing before removal.
- Remove main bearing **1** by pushing it inward toward crankcase.
For removal use tool - **9** -

Inspection / repair:

- Visual inspection.
Inspection should be carried out before removal !

All dimensions measured in fitted condition at 20±10° C / 68±18° F.

Assembly:

- Apply locking agent **E** to bearing **1** and press firmly in place. For assembly use tool - **9** -

Ensure lubrication passages align.
Position in crankcase as specified !

1 D 60 - 80 - 81 - 90:

Slotted lubrication passage has to align with the main gallery at the bottom side of crankcase. Check the small lubrication bore on top for free passage.

Camshaft bearing

Dismantling:

- Check condition of bearing bushing before removal.
- Remove bearing bushing **2** by pushing it inward toward crankcase.
For removal use tool - **13** -

1 D 60 - 80 - 81 - 90:

- Push bearing approximately half way into the crankcase.
Be careful not to damage bore or crankcase.
- Destroy bearing bushing to remove.

Assembly:

- Install and press bearing bushing **2** firmly in place.
For assembly use tool - **13** -
Make sure lubrication passages align.
Position in crankcase as specified !

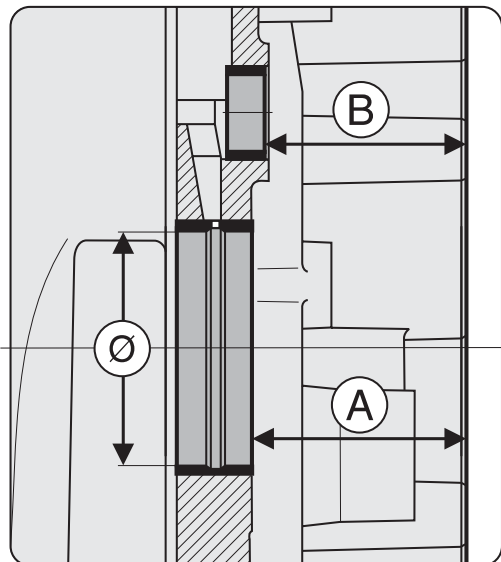
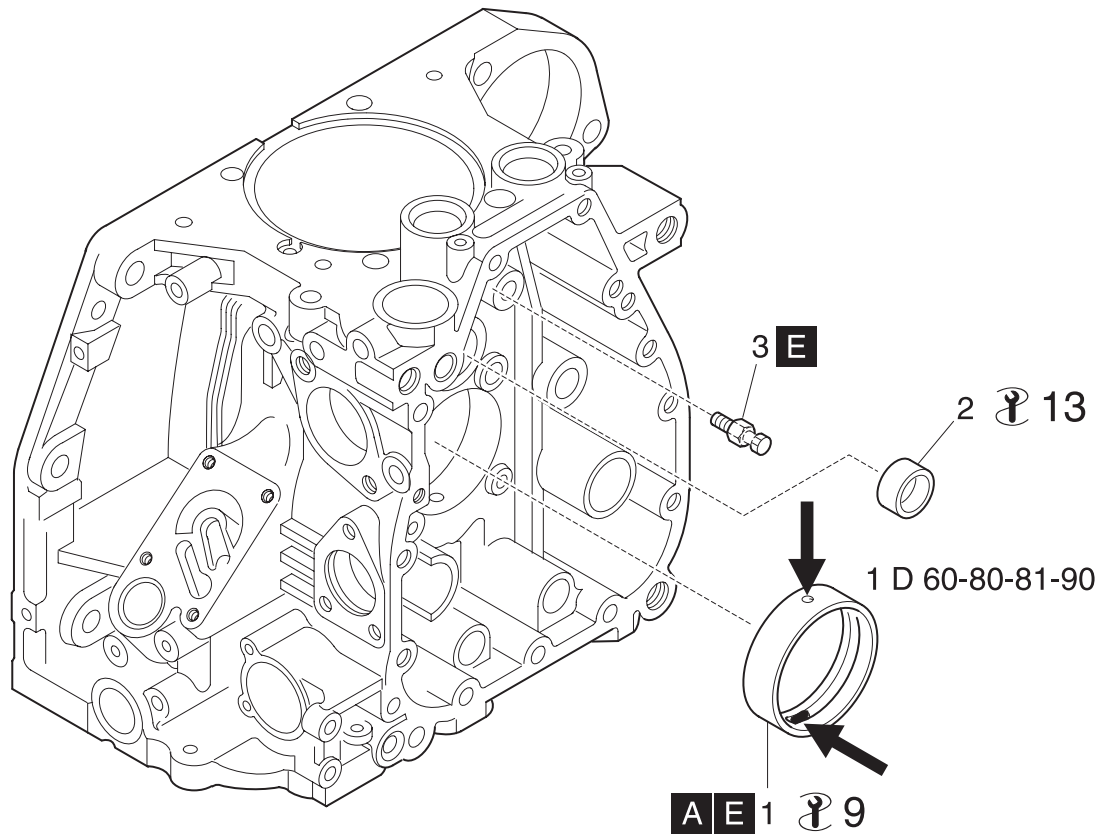

	1D30-31-35-40-41-50	1D60-80-81-90
A (mm)	62.8	59.0
B (mm)	56.5	56.5

	nom.Ø (mm)	max.Ø (mm)	Ø -0.5 (mm)	Ø -0.5 max. (mm)
1D30-31-35-40-41-50	55.01 - 55.05	55.15	54.51 - 54.55	54.65
1D60-80-81-90	65.02 - 65.06	65.15	64.52 - 64.56	64.60

M 01.00 Crankcase

M 01.11 Plugs

For versions without add. counter balance the bores for the balancer shafts are closed with plugs to obtain full oil pressure.

Variant I

up to series no.:

1 D 30.15	A 1 D 35.13
1 D 31.13	A 1 D 40.12
1 D 40.16	A 1 D 41.11
1 D 41.13	
1 D 60.22	1 D 81.15
1 D 80.21	1 D 90.10

In case no fuel feed pump is fitted plug **1** **without** ring groove has to be fitted on both sides. In case a fuel feed pump is fitted plug **2** **with** ring groove has to be used on the operator side instead of plug **1** to guarantee lubrication of rocker arm.

Assembly:

– Push in plugs (chamfer 2 x 45° timing cover direction) firmly until flush with crankcase inside wall

Variant II

from series no. on:

1 D 30.16	1 D 40.17
1 D 31.14	1 D 41.14
1 D 60.23	1 D 81.16
1 D 80.22	1 D 90.11
1 D 90 V/W.10	

(modified lubrication oil duct)

In case no fuel feed pump is fitted plug **2** **with** ring groove has to be fitted on exhaust side. Plug **1** **without** ring groove has to be fitted on operation side.

In case fuel feed pump is fitted plug **2** has to be used on both sides with ring groove.

1 D 90 V:

On both sides, plug **2** **with** ring groove has to be fitted.

In addition, the axle with nozzle **4** and bushes **5** and **6** are mounted.

Axle **4** is fitted in such a way that the spray nozzle points to the middle of the camshaft bearing bore.

Additionally, in both cases plug **3** (with extractor thread towards timing cover) has to be fitted in the bore for intermediate axle.

Variante I

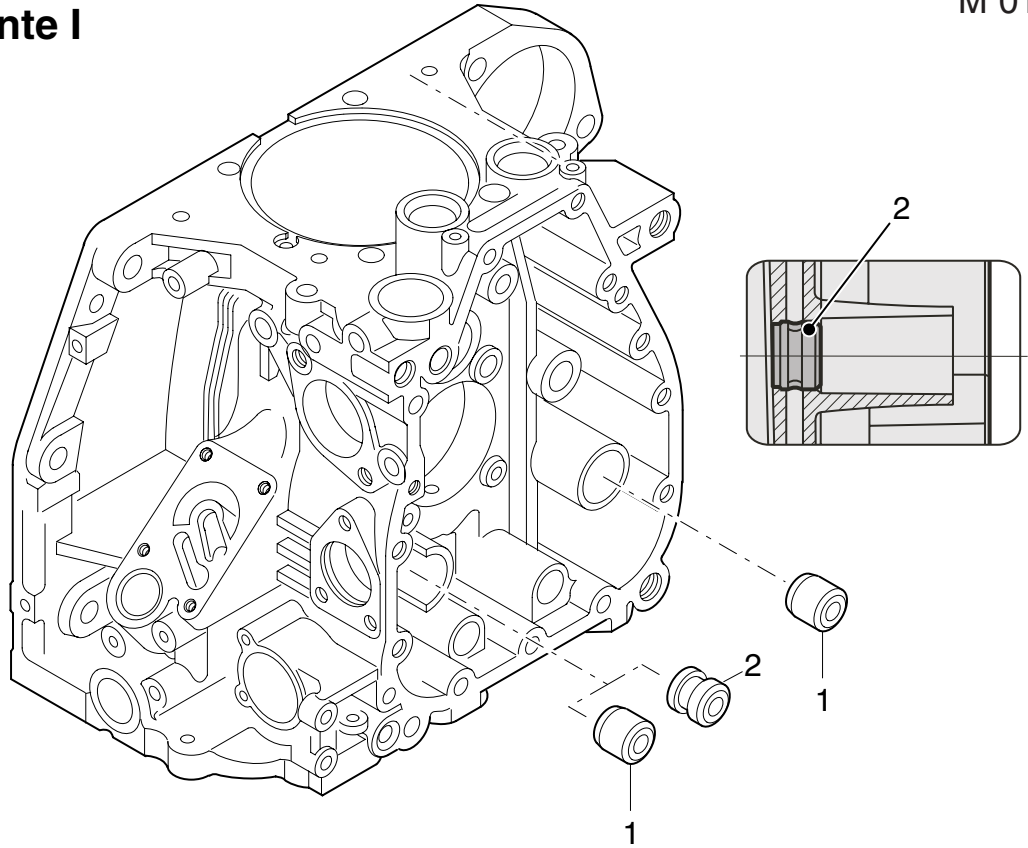

Variante II

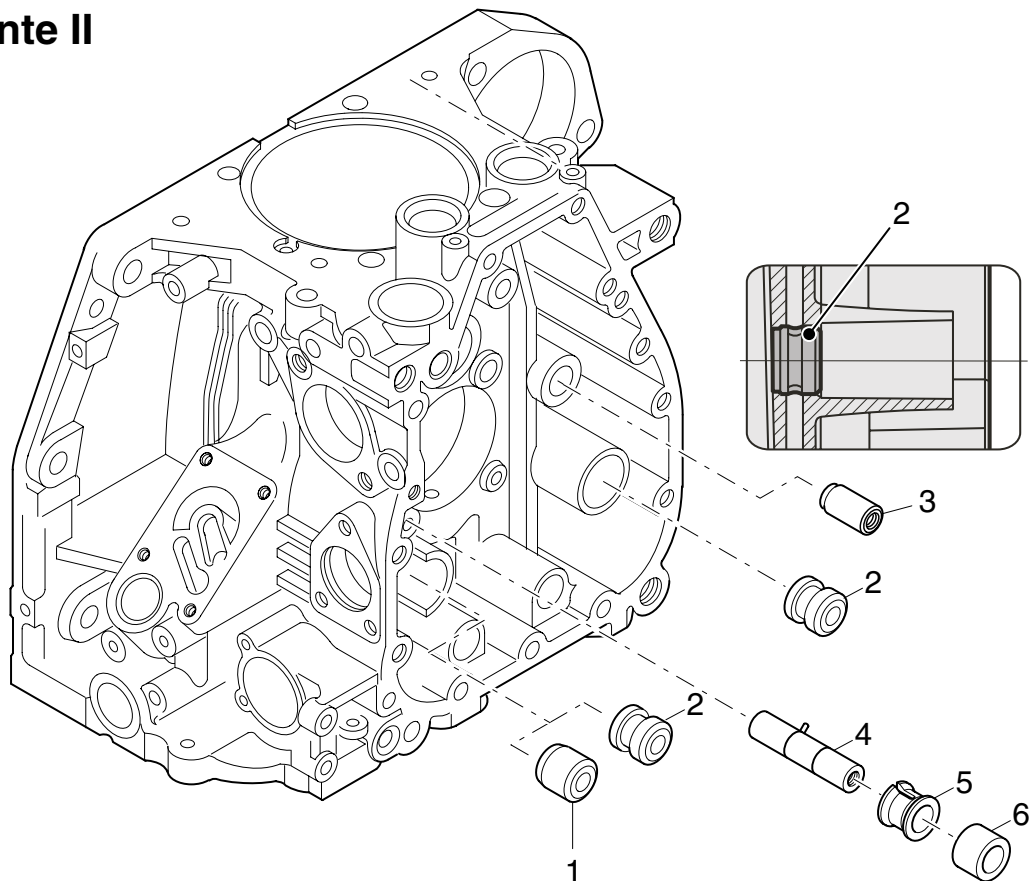

M 01.00 Crankcase

M 01.20 Crankshaft-thrustplate and cam followers

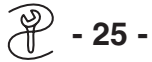

Cam followers

General:

Models S/Z/C = anti-clockwise rotation

Cam followers symmetrically arranged.

Models T/U = clockwise rotation

Cam followers asymmetrically arranged.

Besides the normal cam follower **3** for the inlet valve a separate cam follower **5** for the exhaust valve is fitted onto the cam follower bracket **6**.

The cam follower bracket as well as the thrust plate are fitted together to the crankcase by Allen screws.

1 D 30 - 31 - 35 - 40 - 41 only !

A spacer plate **7** is fitted in addition between the cam follower bracket **6** and the thrust plate **9**.

Preparations:

Ref.: M-Disassembly cross reference scheme.

Dismantling:

- Remove in numerical sequence **1...4/5**.
For removal of part **2** use tool - **25** -

Inspection / repair:

- Check all parts in question for wear and/or any other damage.

Assembly:

- Assemble in reverse sequence **5/4...1**.
Apply locking agent as specified !
Torque to specification !

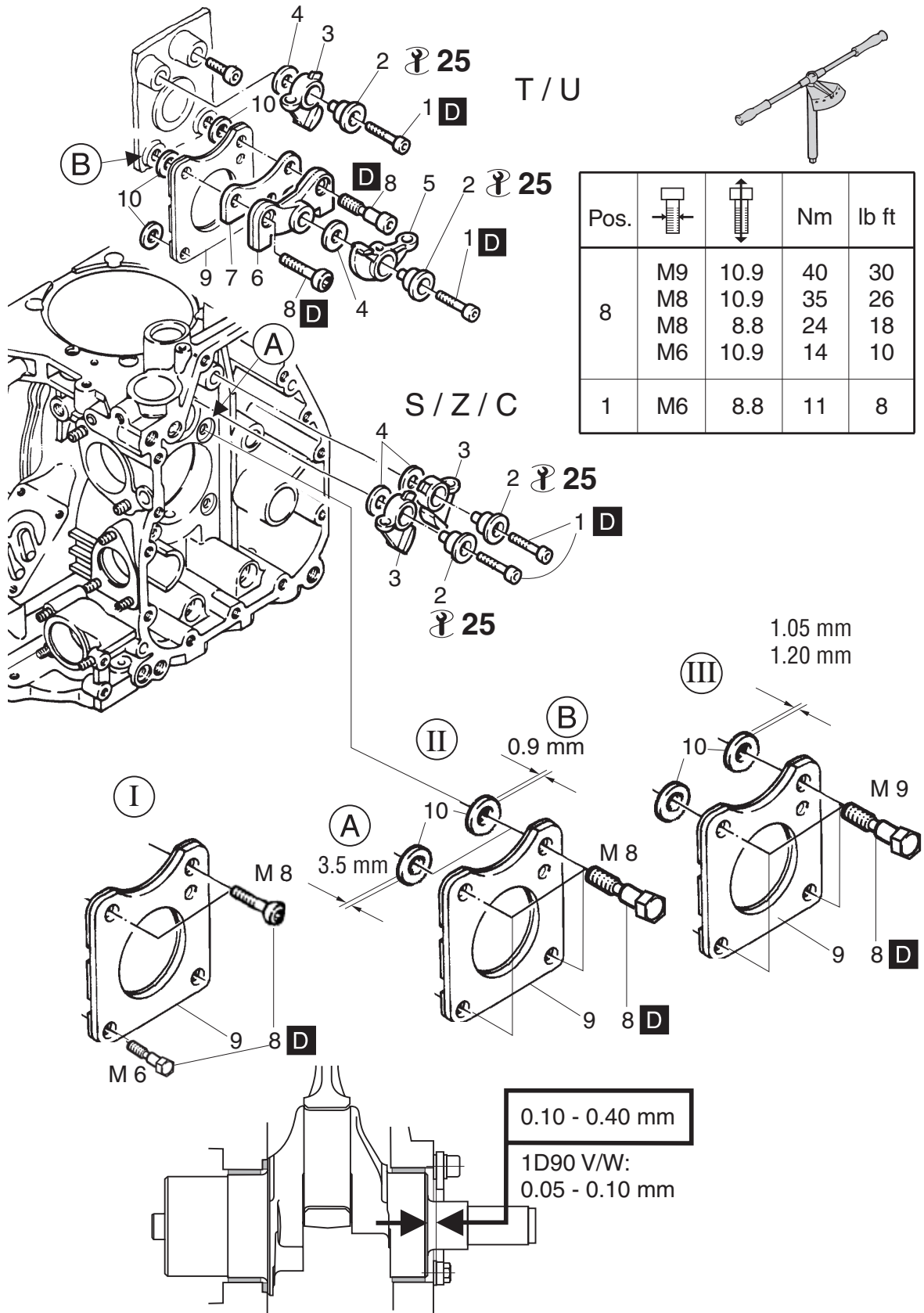

M 01.00 Crankcase

M 01.20 Crankshaft-thrustplate and cam followers

 - 25 -

Crankshaft thrustplate

General:

It is of utmost importance to observe the specified torque settings in connection with the different type tensile strength of the respective retaining screws.

Version I

Fixation by two each retaining screws
M 6 - M 8 without spacer shims.

Version II

Fixation by retaining screws M 8.

A = Point of support recessed in crankcase, spacer shims **10** = 3.5 mm.

B = Point of support bossed in crankcase, spacer shims **10** = 0.9 mm.

Version III as from 1992 onwards

Fixation by retaining screws M 9.

Spacer shims **10** = 1.05 mm and 1.20 mm to obtain correct crankshaft end float.

1D 90 V/W:

These engines have been mounted without governor sided thrust plate. The crankshaft end float is adjusted at the bearing flange. See M 03.10.

Preparations:

Ref.: M-Disassembly cross reference scheme.

Dismantling:

Models S/Z/C

– Remove in numerical sequence **8...10**.

Models T/U

– Remove in numerical sequence **1...10**.

Inspection / repair:

– Check parts for wear, deformation and/or any other damage.

Assembly:

– Assemble in reverse sequence.

Lub. oil pockets on thrust plate face toward crankshaft.

Apply locking agent as specified !

Torque to specification !

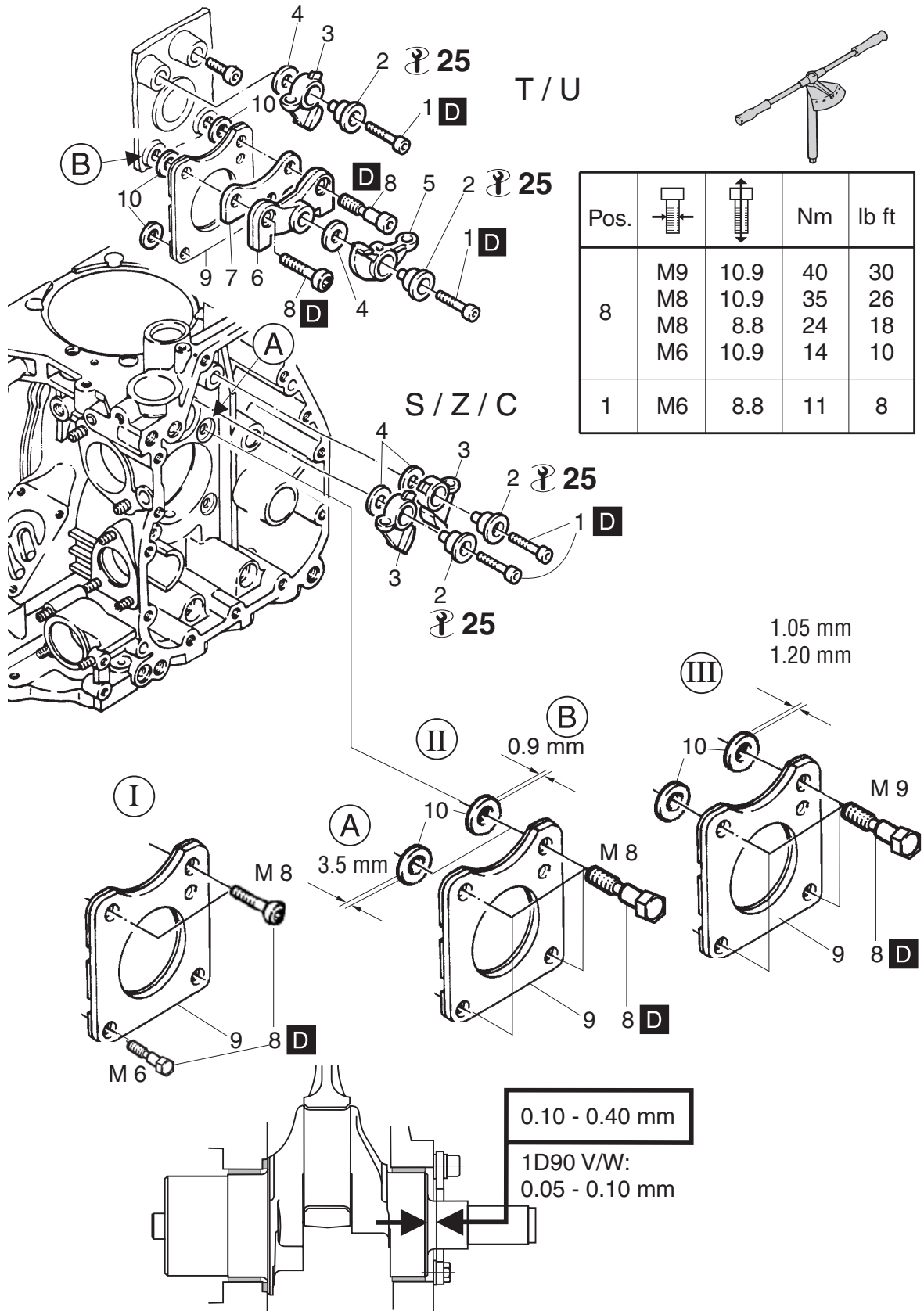

M 01.00 Crankcase

M 01.30 Oil sump and suction sieve



Preparations:

Ref.: M-Disassembly cross reference scheme.

Oil sump

Dismantling:

- Remove in numerical sequence **1...2**.
- Remove oil sump **3** using a plastic hammer.

Inspection / repair:

- Check oil sump for possible cracks, deformations, flatness of sealing surface and any other damage.

Assembly:

- Assemble in reverse sequence **3...1**.
Apply sealant and locking agent as specified.

1 D 30 - 31 - 35 - 40 - 41 only!

Always use flat washers in addition to the lock washers for the retaining screws in pos. **A** to avoid the retaining screw from interfering with the crankcase which will force the base plate from its position.

Suction sieve:

The strainer housing **6** can be used both for anti-clockwise and clockwise engines. Only the assembly position is different.

- At anti-clockwise engines, the stamped **L** on the base plate and molded **L** on strainer housing have to be placed together.

- This is also applicable for clockwise engines (letter **R** accordingly).

The strainer housings of types **1D 30-31-35-40-41-50** and types **1D 60-80-81-90** differ in their height **b** (see chart).

Apply loctite **D** for mounting screws **4**.

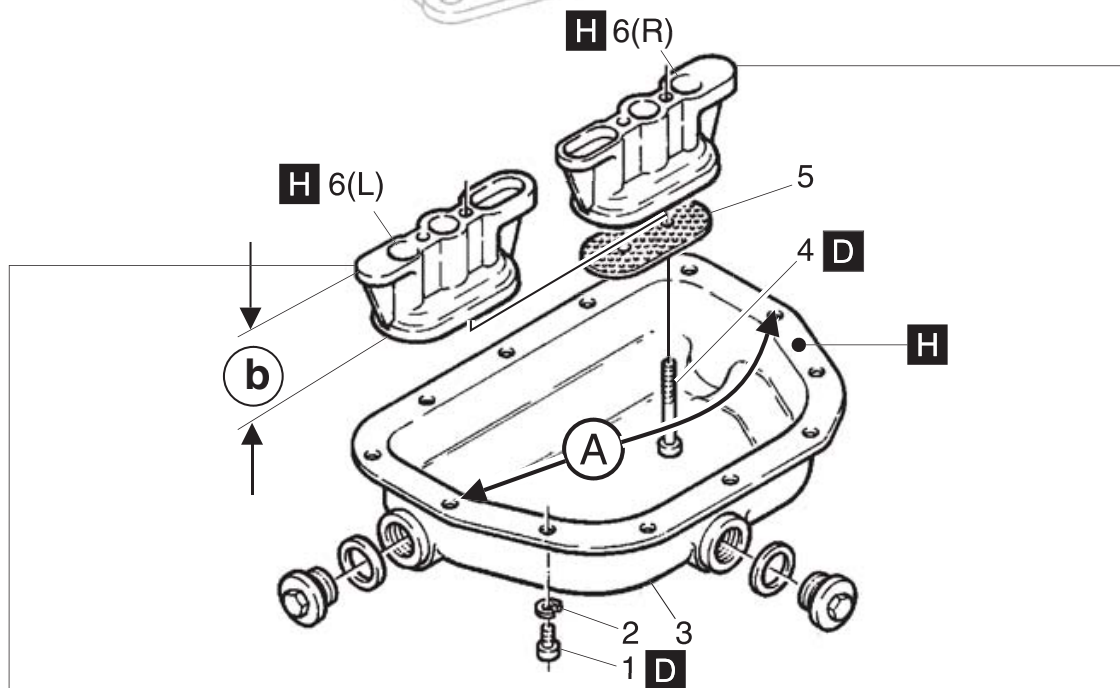
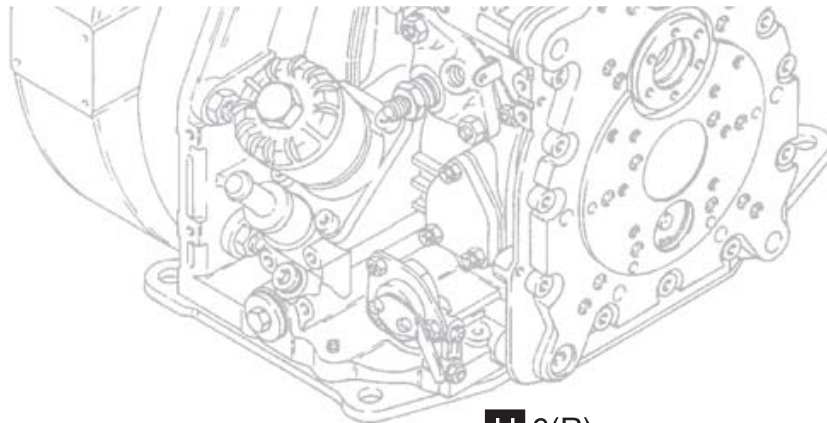

	1D30-31-35-40-41-50	1D60-80-81-90
b (mm)	25	45

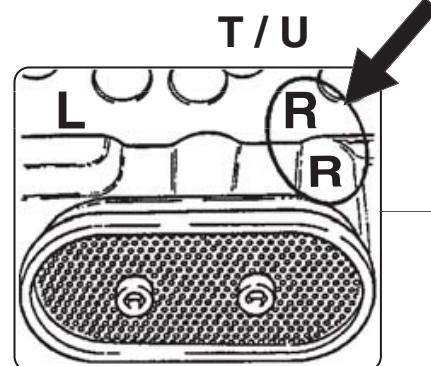
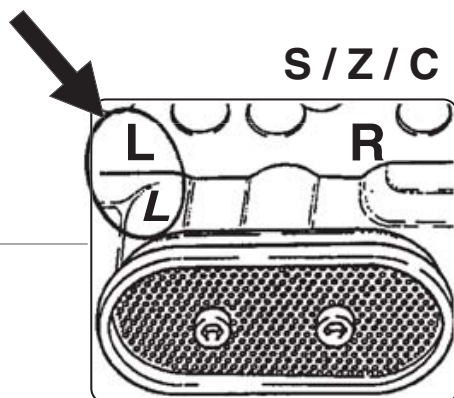

M 01.00 Crankcase

M 01.31 Oil sump 1D 50



General:

An aluminium oil sump with add. cowling is fitted into engines 1D50.

Furthermore, a folding plate **3** is mounted to the bottom plate.

Assembly:

- Seal oil sump **1** with sealing medium **H**.
- Pay attention to correct positioning of fastening screws!

Note:

A = M 8 x 40

shim ring 8 x 14 x 1

B = M 8 x 30

shim ring 8 x 14 x 1

C = M 8 x 30 Z3

D = M 6 x 25

flat washer 6,4

E = M 6 x 16

flat washer 6,4

- Fit screws with screw retention **D** in position **D** and **E**.
- Fixation of cowling **2** with screws **3**.

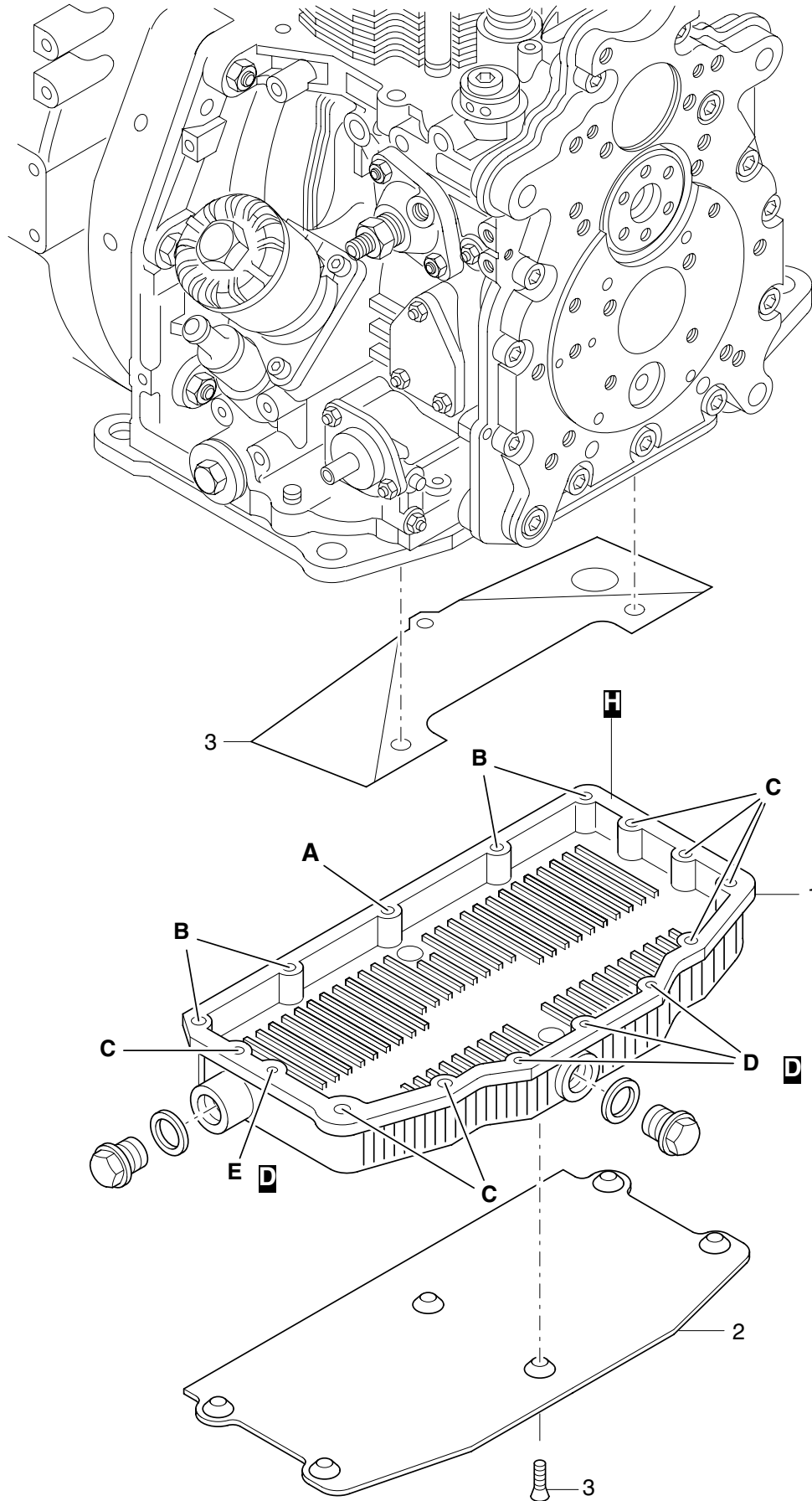

M 01.00 Crankcase

M 01.40 Base plate and oil pressure relief valve



Preparations:

Ref.: M-Disassembly cross reference scheme.

Base plate

Inspection / repair:

- Check base plate for flatness, cracks or any other damage.

Assembly:

- Apply sealing agent **B** onto crank case (see drawing)
- Assemble in reverse sequence **5...1**. Ensure both seal rings remain in position during assembly.
- Install and tighten Allen screws cross-wise and uniformly.
Torque to specification !

1 D 90 V:

Instead of bottom plate **3** a rear panel **9** is installed

- Pay attention to correct positioning of fastening screws!

Note:

a = M 8 x 25 Z4

b = M 8 x 45
spring washer A 8

c = M 8 x 40
spring washer A 8

d = M 8 x 25
joint washer A 8 x 14

- Fit screws with screw retention **D** in position **d**.

Oil pressure relief valve

Dismantling:

- Remove in numerical sequence **6...8**.

Inspection / repair:

- Check relief valve for contamination and/or any other damage.

NOTE:

The relief valve must be replaced as a complete unit.

No repairs are possible !

Assembly:

- Assemble in reverse sequence **8...6**.
Torque to specification !

Crankcase - Sandcasting Sealing surface machined	70 Nm 52 lb ft
Crankcase - Press.- diecasting Sealing surface unmachined	100 Nm 74 lb ft

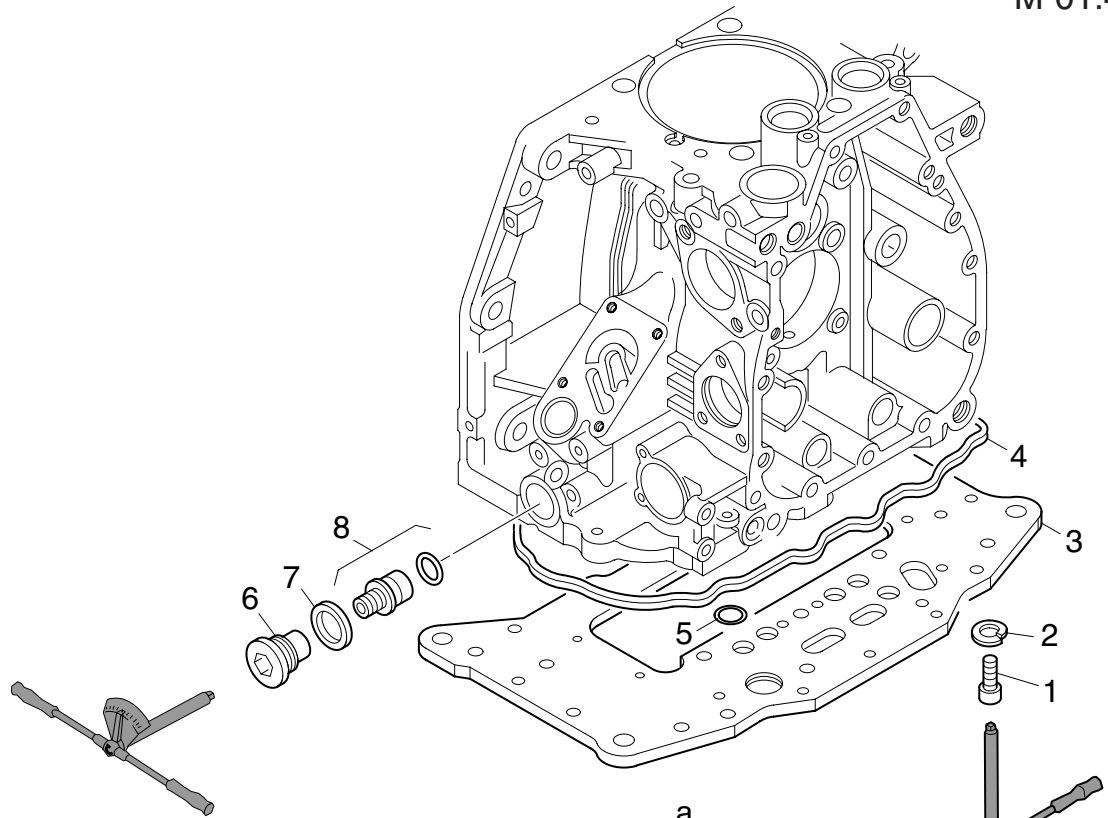

23 Nm
17 lb ft

1D90V/W:

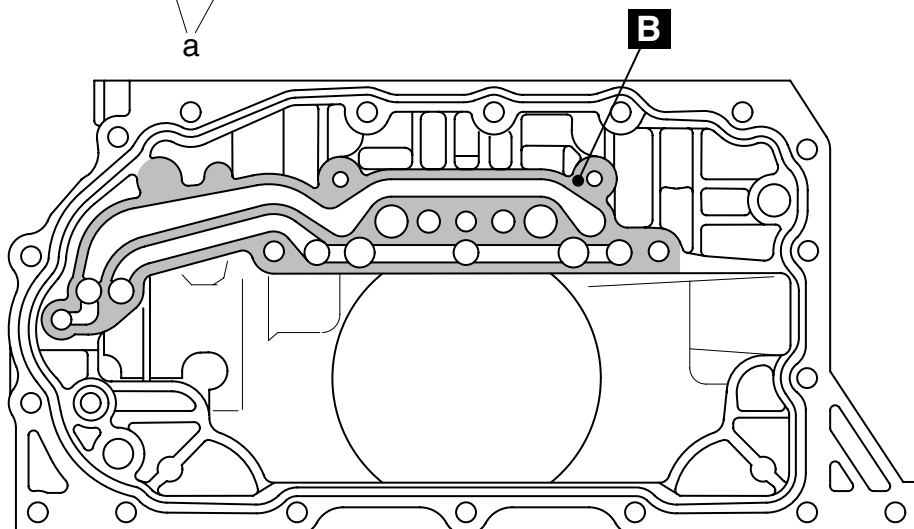
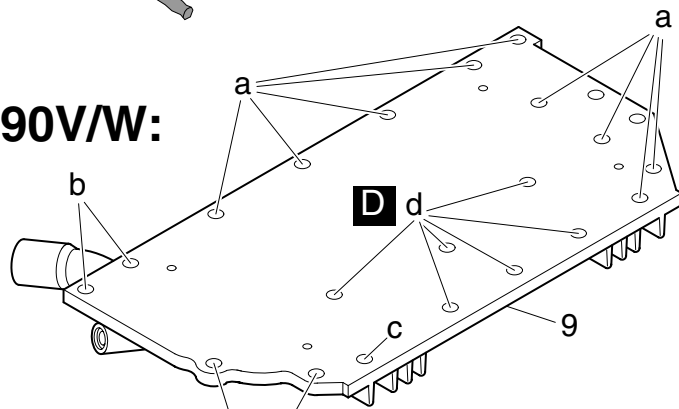

M 01.00 Crankcase

M 01.50 Cyl.-head screw sealants



General:

Sealing caps are used between the crankcase and cyl.-head screws to prevent water and contaminants from entering and causing corrosion.

Replace seal caps whenever head bolts are removed.

NOTE:

Determine the correct position and seal type for the specific engine type.

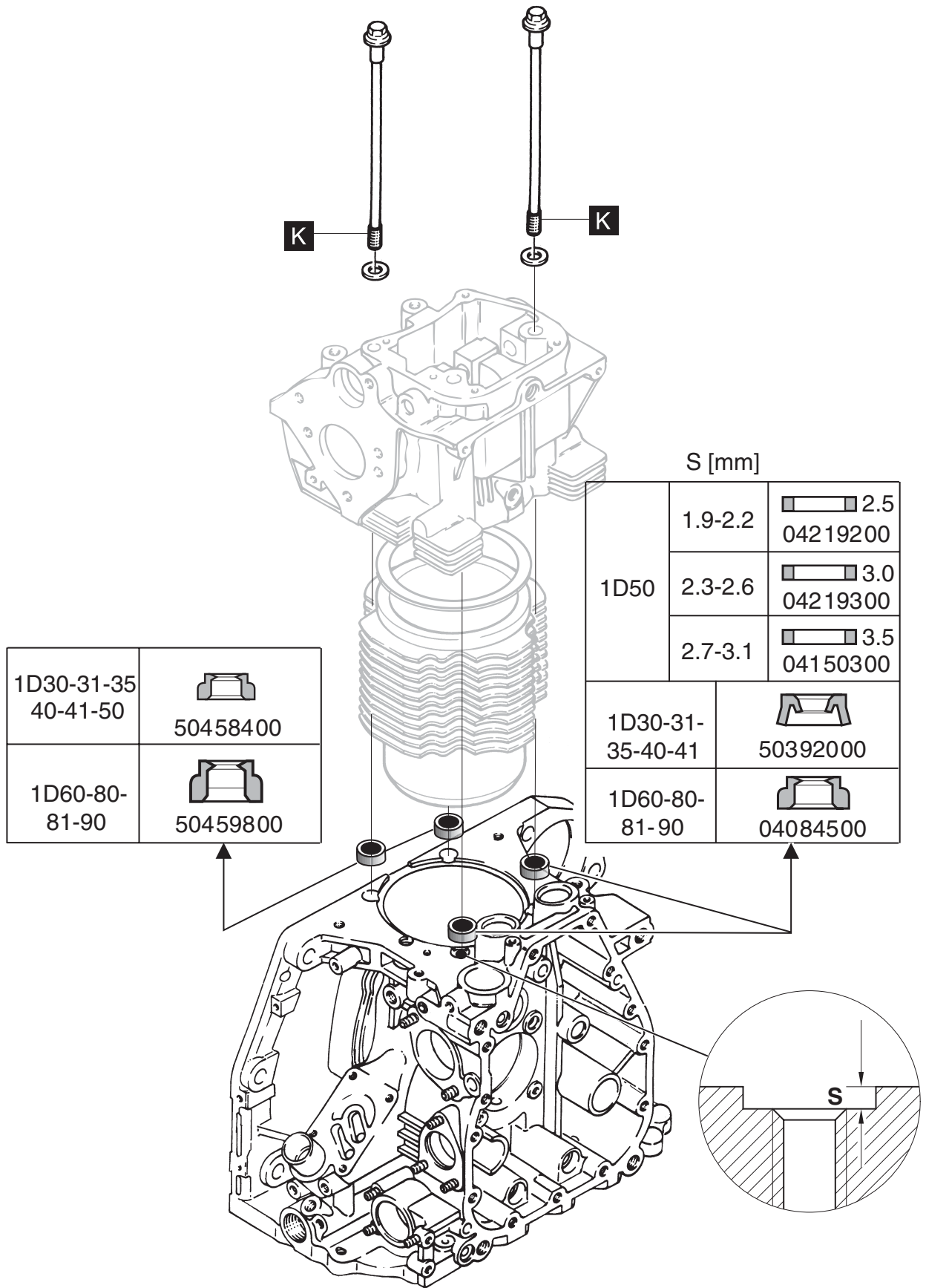

M 02.00

M 02.10

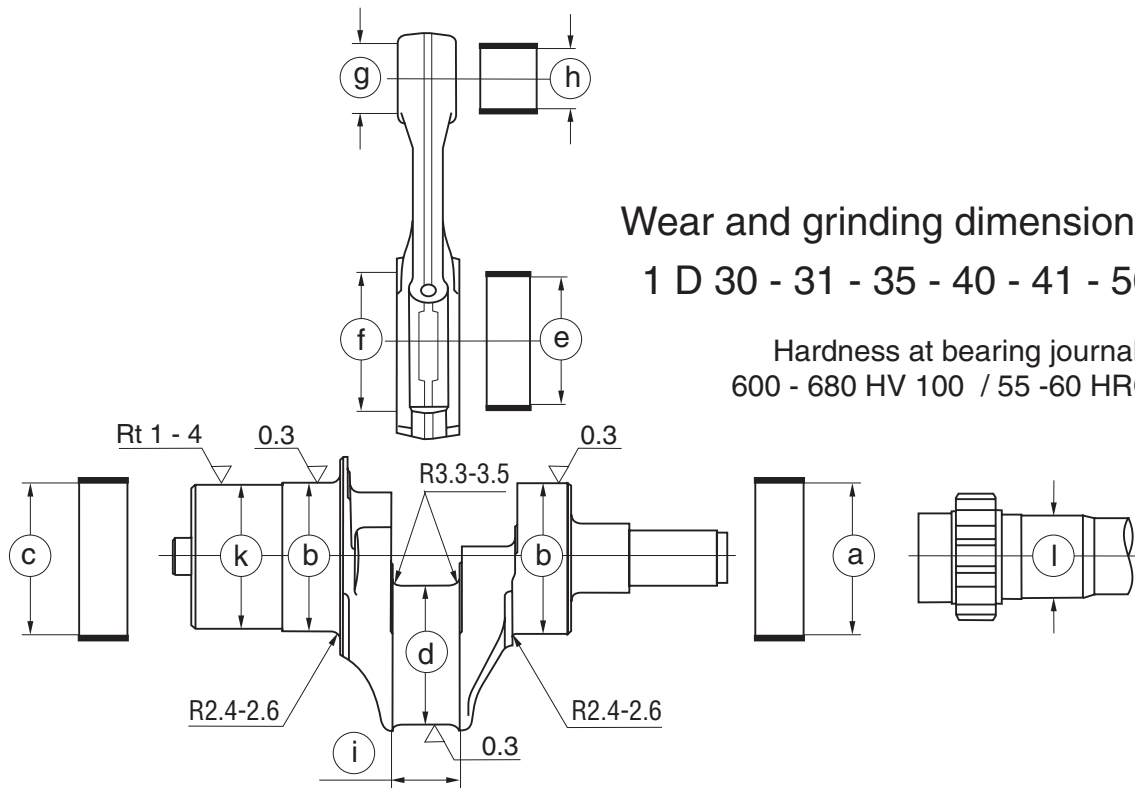

	Nom. value (mm)	Wear tolerance (mm)	Grinding dimensions - 0.5 (mm)	Wear tolerance - 0.5 (mm)
a* Ø	55.01 - 55.05	55.15	54.51 - 54.55	54.65
b Ø	54.97 - 54.99	54.90	54.47 - 54.49	54.40
a - b	0.02 - 0.08	0.25	0.02 - 0.08	0.25
c* Ø	55.05 - 55.09	55.20	54.55 - 54.59	54.70
c - b	0.06 - 0.12	0.30	0.06 - 0.12	0.30
d Ø	51.97 - 51.99	51.90	51.47 - 51.49	51.40
e* Ø	52.02 - 52.06	52.15	51.52 - 51.56	51.65
e - d	0.03 - 0.09	0.25	0.03 - 0.09	0.25
f Ø	55.00 - 55.02	55.05	—	—
g Ø	28.00 - 28.01	28.03	—	—
h* Ø	25.03 - 25.04	25.10	—	—
l	25.00 - 25.05	25.20	—	—
k Ø	51.98 - 52.00	51.80	—	—
l Ø	31.98 - 32.00	31.95 (31.85 on oil seal running surface)		

* Bearings in fitted condition
All dimensions at 20 ±10°C / 68 ± 18°F

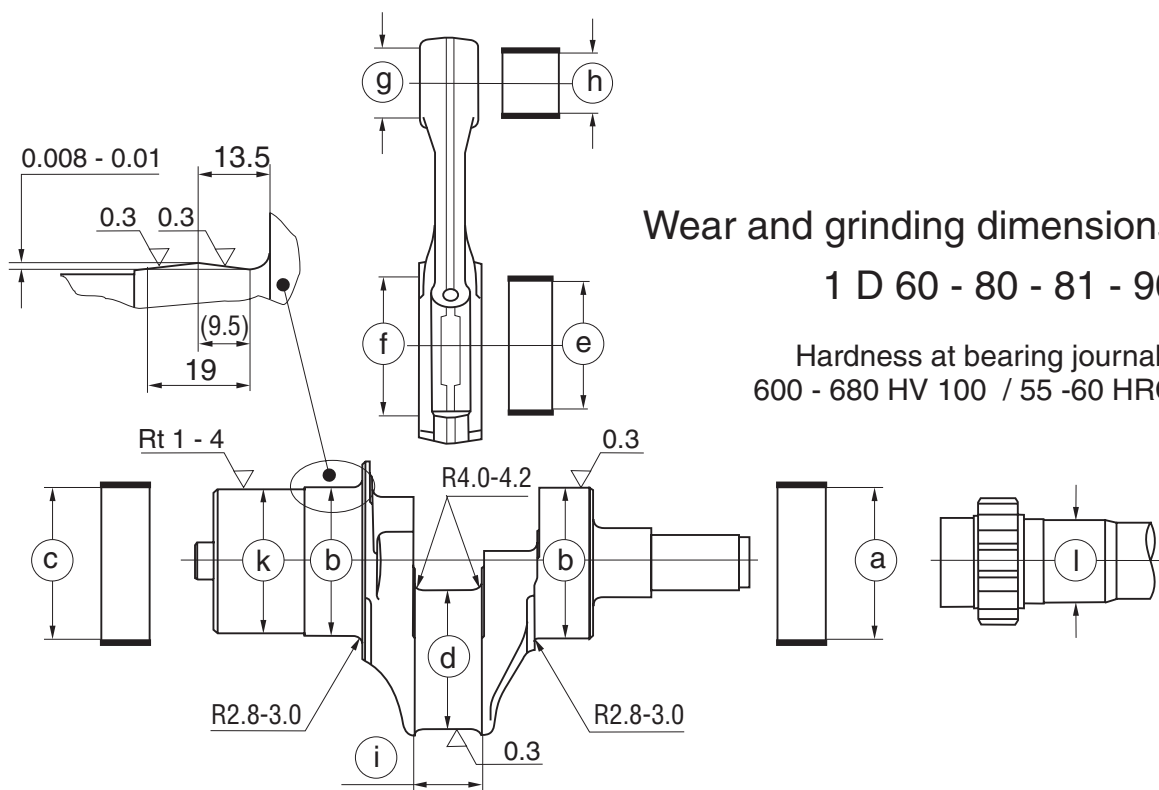

Wear and grinding dimensions

1 D 60 - 80 - 81 - 90

Hardness at bearing journals
600 - 680 HV 100 / 55 - 60 HRC

	Nom. value (mm)	Wear tolerance (mm)	Grinding dimensions - 0.5 (mm)	Wear tolerance - 0.5 (mm)
a* Ø	65.02 - 65.06	65.15	64.52 - 64.56	64.65
b Ø	64.97 - 64.99	64.90	64.47 - 64.49	64.40
a - b	0.03 - 0.09	0.25	0.03 - 0.09	0.25
c* Ø	65.06 - 65.09	65.20	64.56 - 64.59	64.70
c - b	0.06 - 0.12	0.30	0.06 - 0.12	0.30
d Ø	59.97 - 59.99	59.90	59.47 - 59.49	59.40
e* Ø	60.02 - 60.06	60.15	59.52 - 59.56	59.65
e - d	0.03 - 0.09	0.25	0.03 - 0.09	0.25
f Ø	63.00 - 63.02	63.05	-	-
g Ø	33.00 - 33.02	33.03	-	-
h* Ø	30.03 - 30.04	30.12	-	-
l	29.00 - 29.05	29.20	-	-
k Ø	61.98 - 62.00	61.80 (62.60 with fitted wear sleeve)		
l Ø	31.98 - 32.00	31.95 (31.85 on oil seal running surface)		

* Bearings in fitted condition
All dimensions at 20 ± 10°C / 68 ± 18°F

M 02.00 Crankshaft

M 02.20 Crankshaft gearwheel and stubshafts

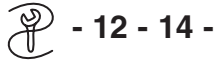

General:

Crankshaft gearwheel respectively stubshaft are shrink fitted.

Preparations:

Ref.: M-Disassembly cross reference scheme.

Dismantling:

- Remove gearwheel **1** respectively stubshaft **2**.
For removal use tool - **14** -

Inspection / repair:

- Check gearwheel or stubshaft for wear or any other damage.

Assembly:

- Put engine onto flywheel side (flywheel fitted) to avoid damaging of flywheel side thrust plate.
- Heat crankshaft gearwheel respectively stubshaft.
In case heating is done on a heater plate put parts onto special heating insert - **12** - to obtain proper distribution of heat over the whole part.
- Strike crankshaft gearwheel respectively stubshaft onto crankshaft until final position using a plastic tip hammer.

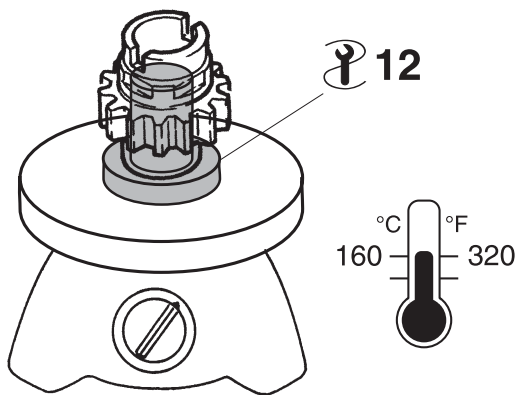
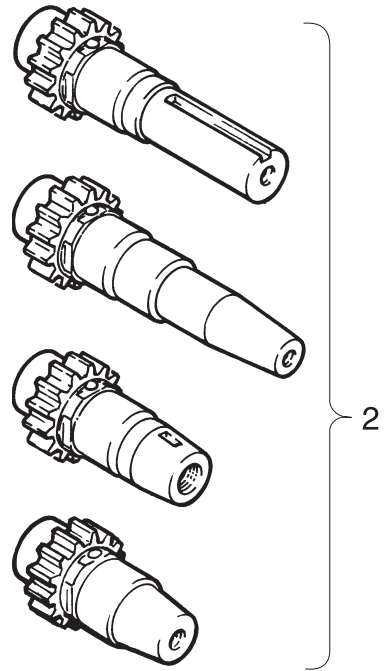
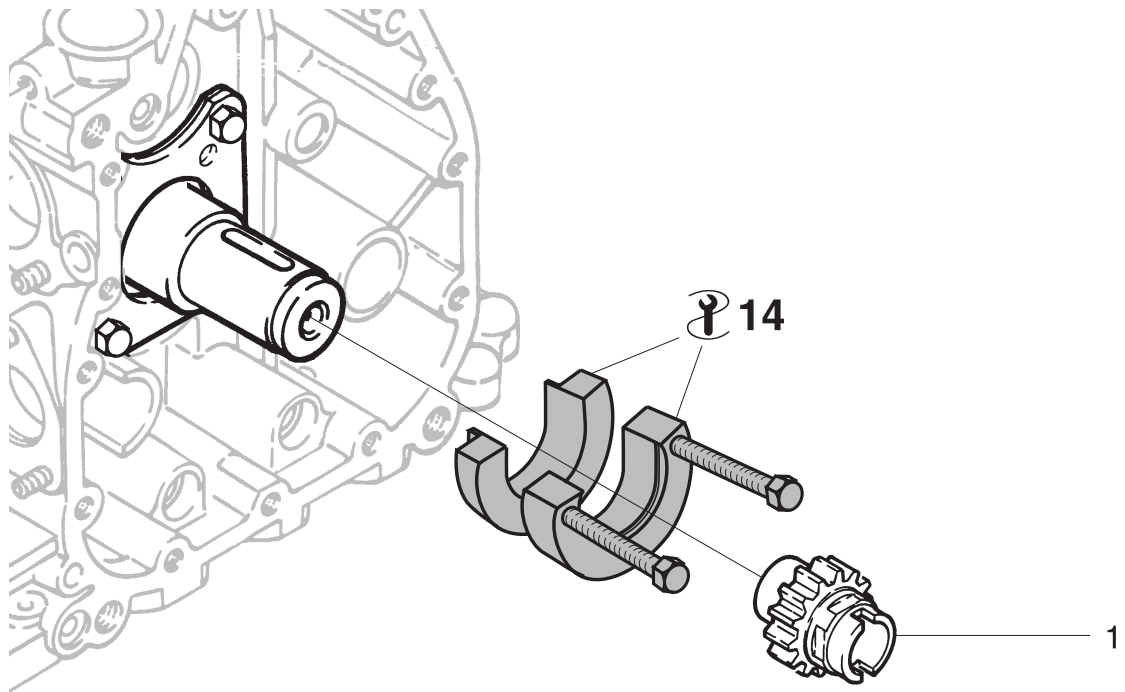

M 02.00 Crankshaft

M 02.30 Crankshaft / Wear sleeve



Preparations:

Ref.: M-Disassembly cross reference scheme.

Dismantling:

- Remove in numerical sequence **1...3**.
Remove counter weight through cylinder bore.

Inspection / repair:

- Visual inspection.
- Check crankshaft for wear and hardness in connection with wear specifications.
Ref.: Chapt. M 02.10

NOTE:

After regrinding or if ever necessary remove crank journal closing cover **4** for cleaning purposes.

For correct replacement proceed as follows:

- Drill and use drill bit or knock closing cover out of its position.
- Remove peened edges carefully to avoid damage of closing cover during assembly.
- Clean whole area in bore as well as oil galleries.
- Place and drive closing cover **4** firmly into corresponding bore in crank journal until flush with straight bore.
Apply high strength locking agent as specified !
Replace closing cover each time to obtain proper sealing.
- Lock closing cover by peening edges around chamfered part above straight bore (closing cover) using a punch or similar tool.

Assembly:

- Assemble in reverse sequence **3...1**.
Torque to specification !

Shaft Repair Sleeve

1 D 60 - 80 - 81 - 90 only!

In case the running surface position of the oil seal ring shows excessive wear a repair sleeve can be used.

Assembly:

- Degrease wear sleeve area on crankshaft.
- Place and fit repair sleeve **5** firmly onto shaft position.
Apply high strength locking agent as specified !
For mounting follow suppliers installation instructions as supplied with each Shaft Repair Sleeve.

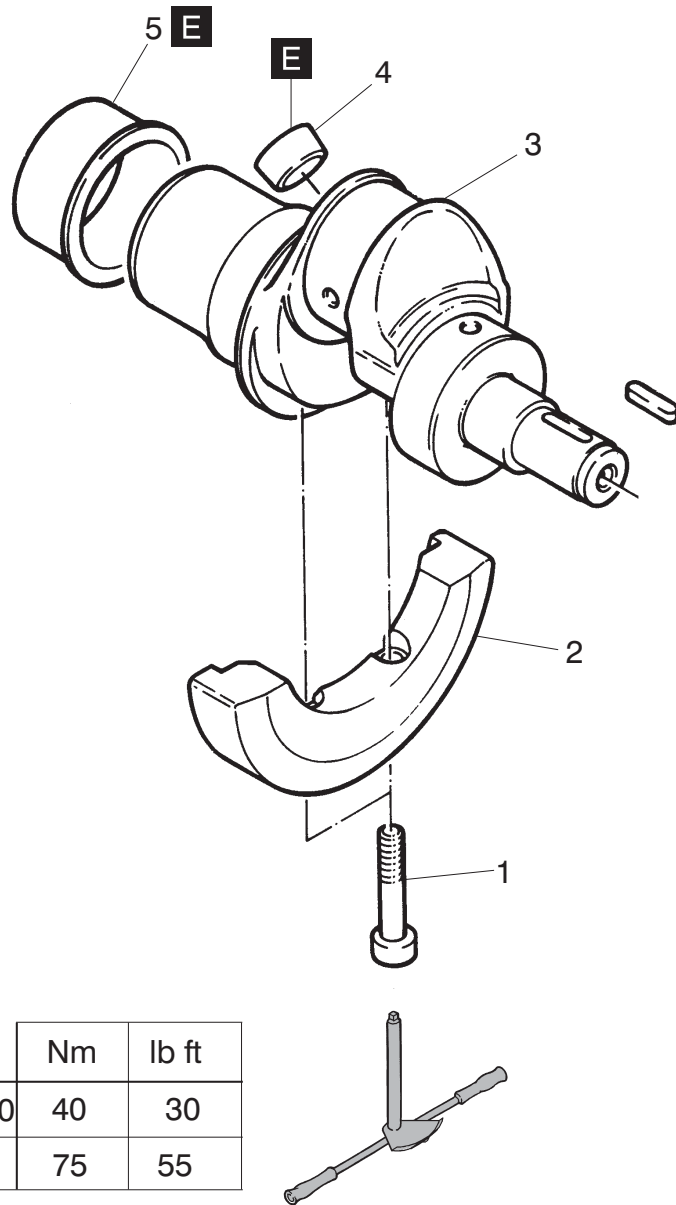

	Nm	lb ft
1D30-31-35-40-41-50	40	30
1D60-80-81-90	75	55

M 03.00 Bearing flange

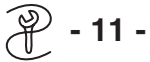

General:

At the very early stages of serial production certain engines have been equipped with a reverse-run safety device fitted into the bearing flange.

This device was later replaced by the anti-kick-back starting handle.

In case of any failure respectively repair and/or replacement contact your nearest HATZ-Distributor.

Preparations:

Ref.: M-Disassembly cross reference scheme.

Dismantling:

It is of utmost importance to remove the two cyl.-head screws **1** flywheel side before disassembling the bearing flange.

- Remove in numerical sequence **2...3**.
- Remove bearing flange **4** using Hex.- or Allen screws M 8 as jacking screws.
- Remove thrust ring **5** from either bearing flange or crankshaft.
- Remove „O“-Ring **6** and oil seal **7**.
- Check condition of main bearing before removal.
- Remove main bearing **8** toward direction of oil seal.

For removal use tool - **11** -

Inspection / repair:

- Visual inspection.
Inspection of main bearing should be carried out before removal!

NOTE:

- Dimensions measured in fitted condition.
- Check thrust ring **5** for wear and / or any other damage.
- Install bearing **8** firmly in place.
For assembly use tool - **11** -.
Make sure lube oil groove faces TOP i.e. towards cyl.-head screws.
A setback of 1 mm against bushing flush has to be obtained.
- Install oil seal **7** firmly in place.
A setback of 1.5 mm against sealing flush has to be obtained.
- Put „O“-Ring **6** onto bearing flange.
- Apply some grease to bearing flange and place thrust ring **5** firmly into its position.

NOTE:

Lube oil pockets on thrust ring facing front!

Assembly:

- Warm crankcase (at least around the bore) up to approximately 80 °C / 175 °F.
- Apply sealing agent **B** onto bearing flange (see drawing).
- Install bearing flange firmly in place.
Ensure thrust ring **5** remains in position during assembly.
- Assemble in reverse sequence **3...2**.

NOTE:

Pay attention to flat washers and Hex.-nuts.
Washers hardened !

Hex.-nuts property class - 10 !

- Tighten Hex.-nuts crosswise and uniformly.

Torque to specification !

- Assemble cyl.-head screws **1**.

	Nm	lb ft
1D30 - 31 - 35 - 40 - 41 - 50	50	37
1D60 - 80 - 81 - 90	80	59

Ø	60-80-81-90	30-31-35-40-41-50
nom.	65.06-65.12	55.05-55.11
max.	65.20	55.20
-0.5mm	64.56-64.59	54.55-54.59
-0.5max.	64.70	54.70

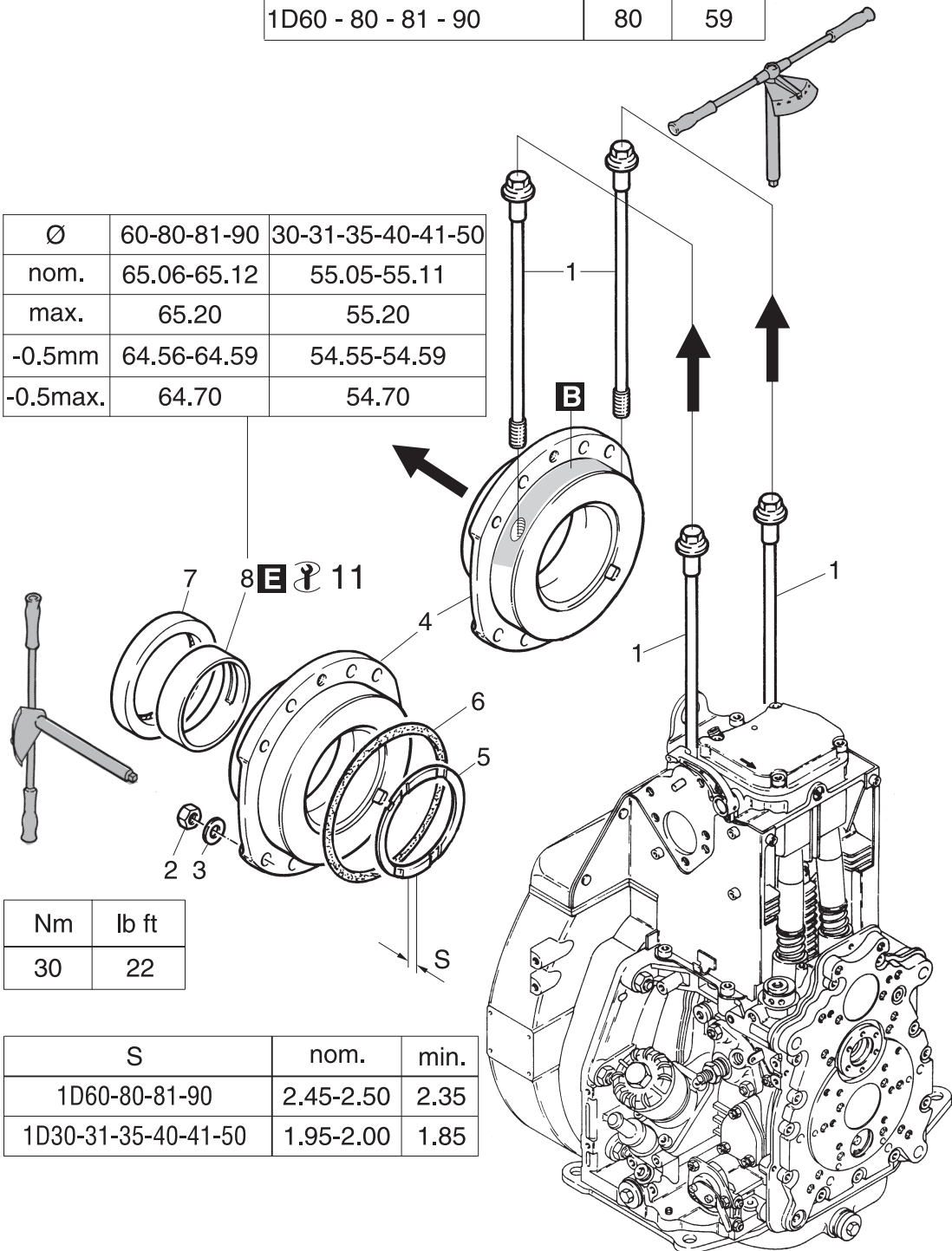

Nm	lb ft
30	22

S	nom.	min.
1D60-80-81-90	2.45-2.50	2.35
1D30-31-35-40-41-50	1.95-2.00	1.85

M 03.00 Bearing flange

M 03.10 Bearing flange 1D90V / W

Dismantling / Wear measurements:

- see M 03.00

General:

The crankshaft axial clearance of engines 1 D 90 V/W is limited at the bearing flange **1** in both directions.

Additionally, to the thrust ring **2** a second thrust ring **3**, collar bush **4** and between flywheel and crankshaft a washer have been fitted.

In order to prevent the thrust ring **3** from rotating two spring pins **6** have been pressed into the bearing flange **1** in an excess length of 2 mm.

Spring pins **7** have been pressed in crankshaft until bottom and serve as tappet for collar brush **4**.

The oil seal **8** always have to be renewed, as it has to be removed for mantling and dismantling of collar brush **4**.

Crankshaft axial clearance:

The axial clearance of crankshaft is being adjusted with a shim ring **9** between bearing flange **1** and thrust ring **2**.

- Mount bearing flange with thrust ring and collar bush to the dismantled crankshaft and determine axial clearance.
- Adjust mentioned axial clearance by inserting the resp. shim rings.

Assembly:

- Warm-up crankcase to approx. 80°C/175°F.
- Fixation of thrust ring **2** and shim ring **9** into bearing flange with grease (oil groove faces towards crankshaft)
- Insert shim ring **3** in bearing flange (oil groove faces towards flywheel).
- Install bearing flange in crankcase.
- Mount **8** nuts with washers and tighten acc. torque (33 Nm).
- Mount collar bush with O-ring **10** onto crankshaft (spring pins **7** must be in a laying position in the groove of collar bush)
- Insert new oil seals **8**.

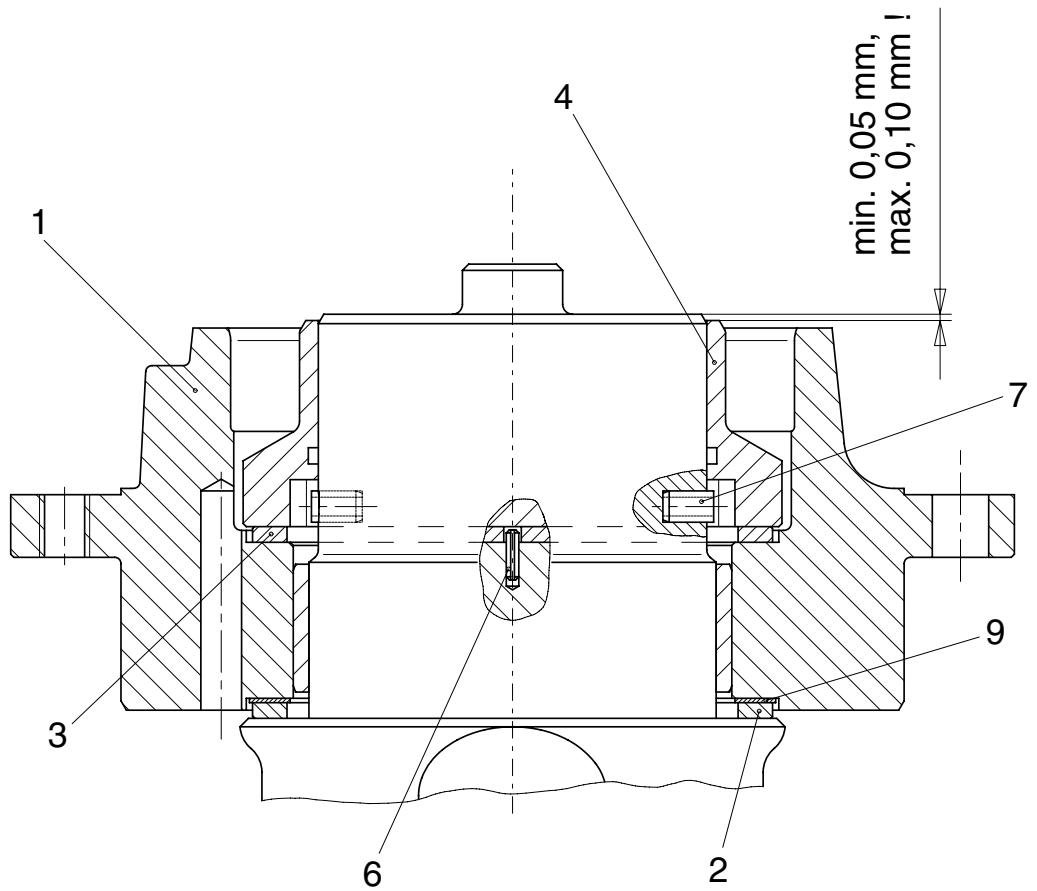
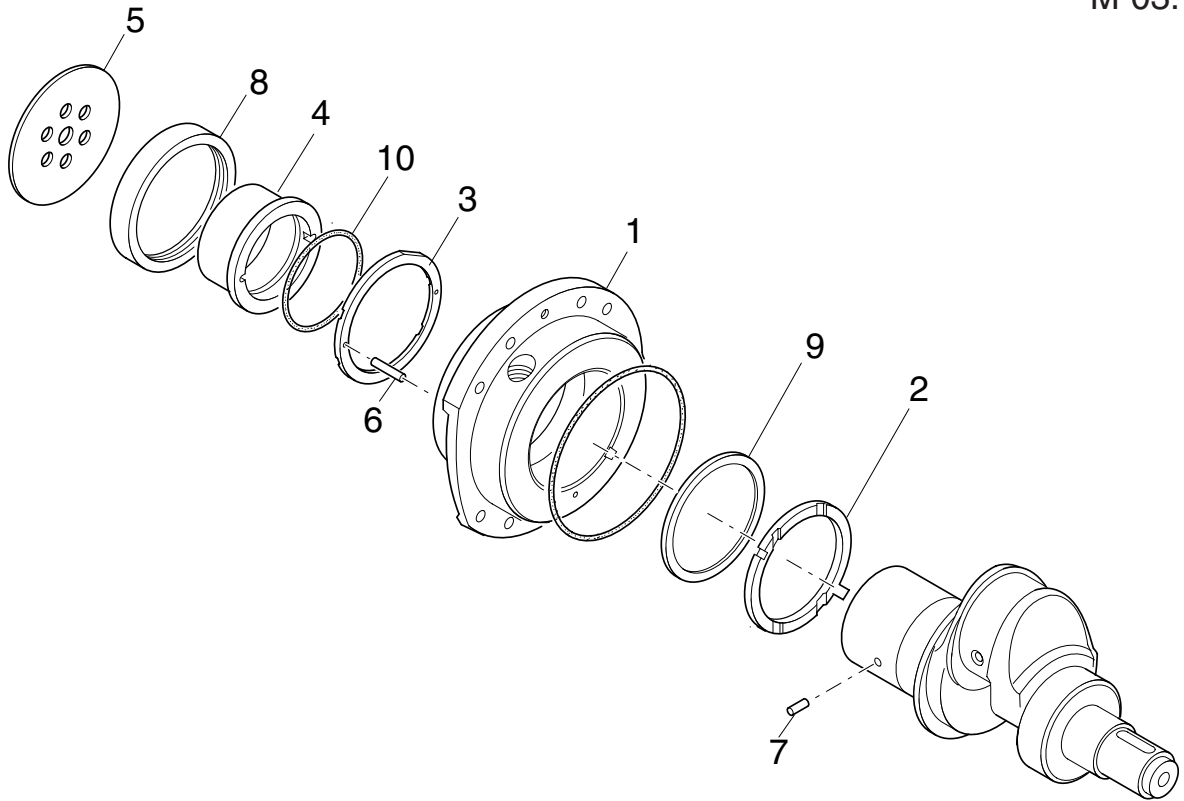

M 04.00 Camshaft and balancer unit

M 04.00 Camshaft and balancer unit

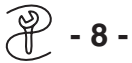

Preparations:

Ref.: M-Disassembly cross reference scheme.

Camshaft

Dismantling:

- Lift cam followers away from camshaft. If possible put engine onto flywheel.
- Remove (pull) camshaft **1**.

Inspection / repair:

- Check running surfaces as well as oil seal position and gear teeth for wear

Assembly:

Install camshaft **1** firmly into bore position. Ensure gear timing marks match!

Balancer unit

Dismantling:

- Remove (pull) idler gears **2** from shafts.
 - Remove drive gears **3** and balancer shafts **4**.
- For removal use tool - **8** -

Inspection / repair:

- Check running surfaces and gear teeth for wear

Assembly:

- Install balancer shafts **4** firmly into crankcase. Take care for correct positioning of balancers ! Long end of weights to inside.
- Lock balancers inside the crankcase to obtain fixed position during assembling of drive gears **3**. Use screw-unit combination of corresponding length.
- Heat drive gears **3**.
- Place and strike drive gears **3** onto balancer shafts until final position, markings visible.
- Remove fixation and check balancers **4** for free movement.
- Assemble camshaft **1** and idler gears **2**. Ensure gear timing marks match!

1D30-31-35-40-41-50 ~ 50mm
1D60-80-81-90 ~ 60mm

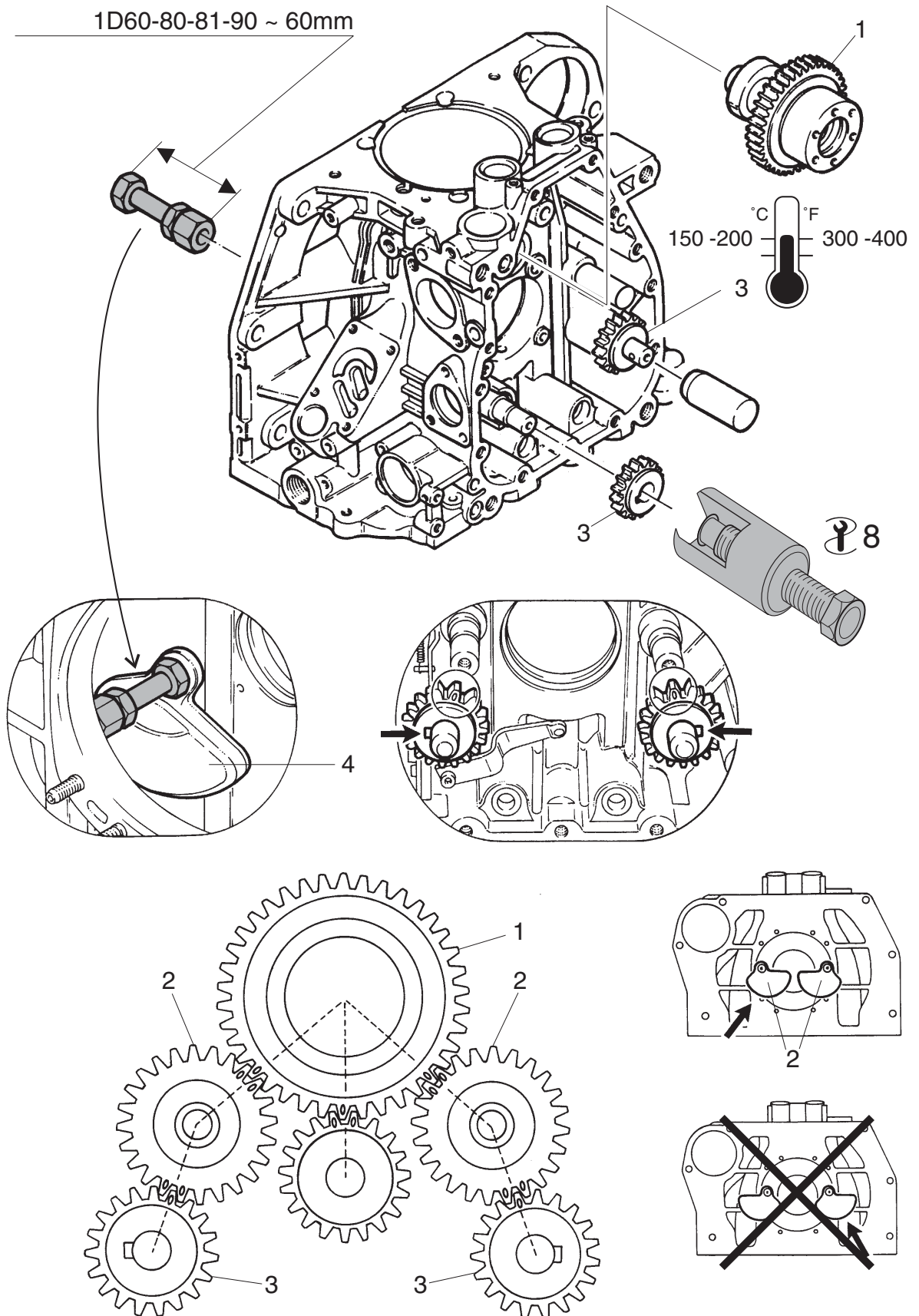

M 05.00 Piston with connecting rod

M 05.10 Piston and piston rings

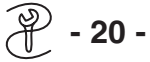

General:

1 D 80 - 81 only!

Pistons are different in their combustion bowl cavity.

1 D 40 only!

Pistons available for two different compression ratios.

Preparations:

Ref.: M-Disassembly cross reference scheme.

Dismantling:

- Remove circlips **1**.
- Remove (push) gudgeon pin **2** and lift off piston **3**.
- Remove piston rings.
For removal use tool - **20** -

Inspection / repair:

- Check piston rings for wear or any other damage.
- Check piston rings for axial clearance in piston ring grooves.
- Clean piston ring grooves and piston rings if necessary.
- Check piston rings for wear in connection with wear specifications.

Ref.: Chapt. M 06.00

Assembly:

- Place piston rings into their corresponding grooves.
Observe TOP marks on piston rings !
- Offset the piston ring gaps by approximately 120° to one each other.
- Place piston **3** onto conrod and insert gudgeon pin **2** (ensure that the combustion cavity in the piston crown faces towards flywheel side / injector position).
- Ensure circlips are correctly seated !

1 D 40		
ε	20.5	22.0
h (mm)	12.0	10.9

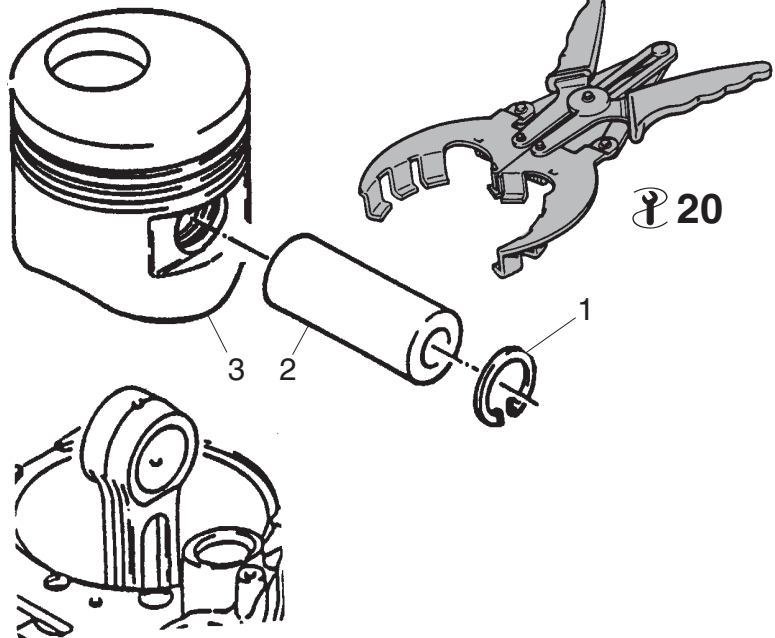
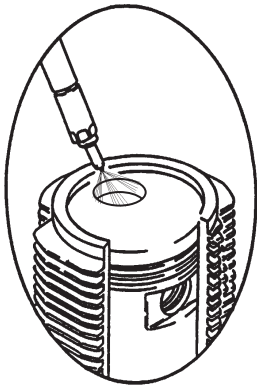
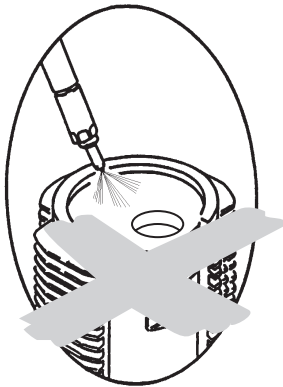
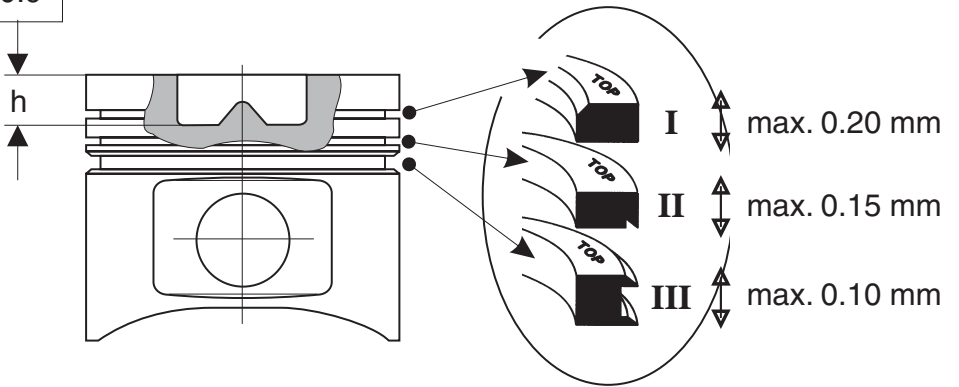

1D80

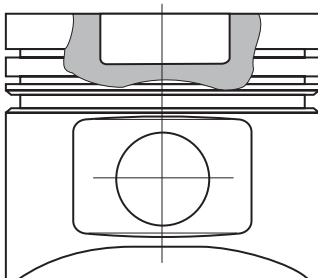

1D81

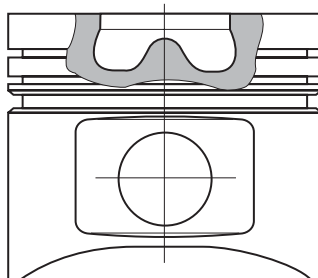

M 05.00 Piston with connecting rod

M 05.20 Connecting rod



General:

Connecting rods can be fitted either way as far as matching-No. and engine speed is concerned.

The broaching cut as well as an additional pin location are the basis for the location top to bottom.

Don't interchange parts i.e. matching-Nos. have to correspond !

As of series stand: 1D30.17, 1D31.15, 1D40.18, 1D41.15, 1D50.10, 1D60.20, 1D80.20, 1D81.13, 1D90.10, 1D90V/W.10: Introduction of connecting rods with even mating face and fitting bolts.

Pay attention that during assembly all matching numbers are on top of each other.

Preparations:

Ref.: M-Disassembly cross reference scheme.

Dismantling:

- Unscrew connecting rod bolts **1**.
- Remove connecting rod **2/3** separately from top and bottom.
- Remove big end bearing **4**.

Inspection / repair:

- Check big end bearing as well as basic bore in connecting rod and small end bushing for wear or any other damage.

NOTE:

All dimensions measured in fitted condition at $20 \pm 10^{\circ}\text{C}$ / $68 \pm 18^{\circ}\text{F}$.

Connecting rod bolted, bolts set to tightening torque !

- Check connecting rod for possible skewness.

Don't realign !

- Remove (press) small end bush **5** if necessary.

Assembly:

- Press small end bushing **5** centrally into small end. Ensure lubrication bores align !
- Place big end bearing **4** into connecting rod.
- Moisten big end bearing and crankshaft work pin with engine oil (don't use molykote grease!)
- Install connecting rod **2/3** onto crank journal. Ensure matching-Nos. match !
- Install and tighten bolts **1** uniformly. Torque to specification !
- Check connecting rod with bearing in assembled condition for free movement on crankshaft journal only after bolts are torqued to specification.
- Turn engine loose before first start (appr. 10 times)

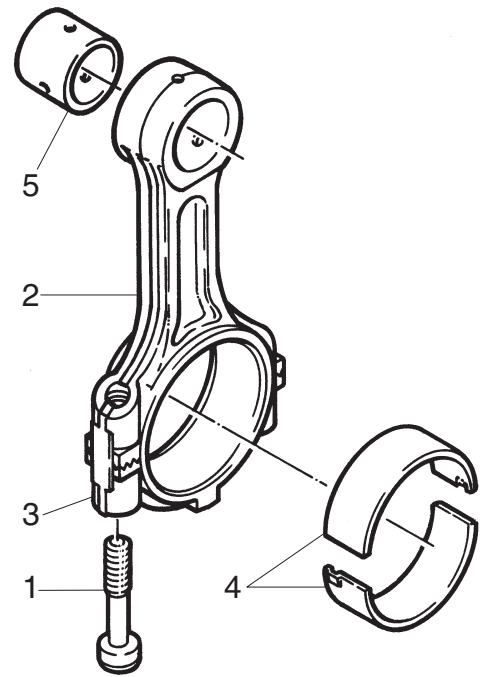
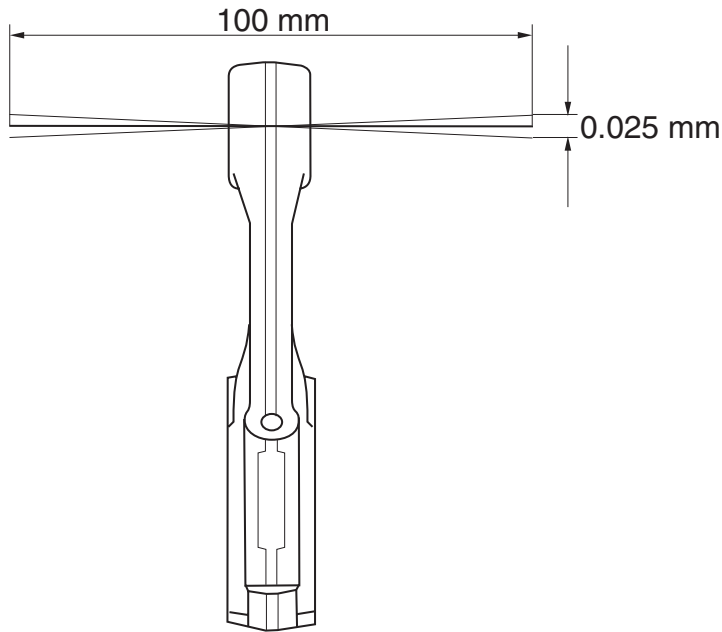

	Nm	lb ft
1D30-31-35-40-41-50	40	30
1D60-80-81-90	85	63

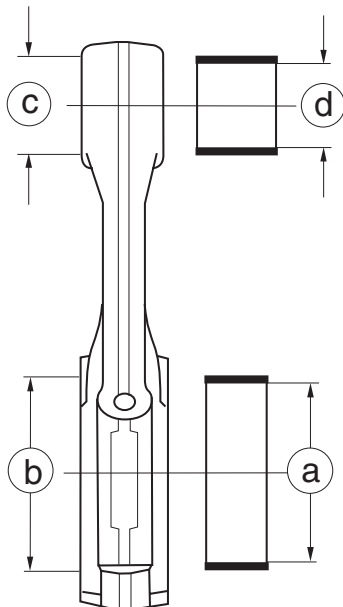
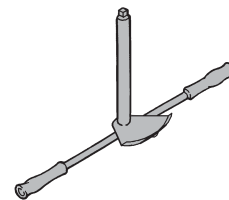

1D30-31-35-40-41-50	nom. (mm)	max. (mm)
a Ø	52.02 - 52.06	52.15
b Ø	55.00 - 55.02	55.05
c Ø	28.00 - 28.01	28.03
d Ø	25.03 - 25.04	25.10

1D60-80-81-90	nom. (mm)	max. (mm)
a Ø	60.02 - 60.06	60.15
b Ø	63.00 - 63.02	63.05
c Ø	33.00 - 33.02	33.03
d Ø	30.03 - 30.04	30.12

M 06.00 Cylinder



Preparations:

Ref.: M-Disassembly cross reference scheme.

Dismantling:

- Remove (pull) cylinder carefully from piston.

Inspection / repair:

- Check cylinder for broken cooling fins, wear, score marks or any other damage.

Index of piston ring wear

To be measured at the very bottom end of the cylinder where normally no wear at all occurs during operation.

- Insert respective piston ring which should be checked into the cylinder. Take care for right-angled position !
- Measure dimension **a** with feeler gauge and compare with figures as indicated in Tab. **A**.
These data refer to oversize as well. Piston rings exceeding figures as indicated have to be replaced!

Index of cylinder wear

To be measured at the upper end of contact area of piston rings i.e. in the area where usually the highest amount of wear occurs.

- Insert new piston ring. Take care for right-angled position !
- Measure dimension **b** with feeler gauge and compare with figures as indicated in Tab. **A**.
These data refer to oversize as well. If the max. figure is exceeded the cylinder is worn out and has to be replaced or used for re-conditioning to oversize as indicated in Tab. **B**.

Assembly:

- Offset the piston ring gaps by approximately 120° to each other to avoid excessive blow-by. Piston rings and cylinder have to be properly oiled !
- Set the scale of the piston ring clamping device - **21** - dependant upon diameter of piston.
- Carefully slide the collar over the piston rings and clamp the tightener.
- Carefully fit the cylinder !
As soon as the cylinder has been slid over the piston rings, release the tightening strap and remove the clamping device.

Honing

General:

If an already run-in but not worn cylinder is dismantled and re-used the cylinder has to be re-honed.

The same procedure is applicable for engines, which due to low load have not broken-in and therefore show excessive oil consumption due to cylinder glazing. In this case the glazed smooth cylinder wall must also be honed.

After re-honing measure piston ring gaps again. The honing process as such needs certain experience and should be carried out by a HATZ-Distributor or any other authorized workshop.

For honing use tool - **29** -

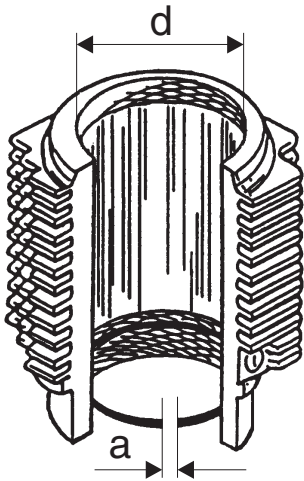

Tab. A

dim.(max.) mm	1D30-31 1D35-40	1D41-50-60	1D80	1D81-90	
a	0.45	0.45	0.55	0.60	
b	0.8	1.0	1.2	1.2	
a	0.45	0.45	0.55	0.60	
b	1.4	1.6	1.8	1.8	
a	0.40	0.40	0.40	0.45	
b	1.2	1.4	1.6	1.6	

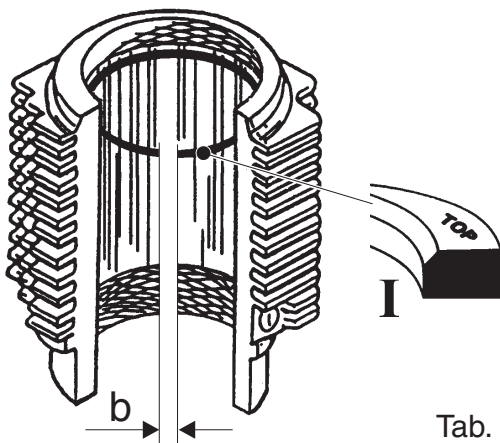

Tab. B

dim. d	1D30-31-35-40	1D41	1D60	1D80-81	1D90	1D50
nom.	86.00 - .01	90.00 - .01	88.00 - .01	100.00 - .01	104.00 - .01	97.00 - .015
+ 0.5	86.50 - .51	90.50 - .51	88.50 - .51	100.50 - .51	104.50 - .01	—
+ 1.0	87.00 - .01	91.00 - .01	89.00 - .01	101.00 - .01	—	—
max.	+ 0.12 mm			+ 0.15 mm		+ 0.12 mm
Ra (μ)	0.9 - 1.3					0.5 - 0.9

M 06.00 Cylinder

Cylinder 1D50:

For 1D50 engines, a press-fit-sleeve is assembled to aluminium cooling jacket, hence in case of wear a sleeve replacement is possible.

Sealing between sleeve and jacket is made by an O-ring at top and by a glued on gasket for bottom.

During assembly of sleeve to jacket, apply grease **K** in the lower region in order to avoid damages to the O-ring.

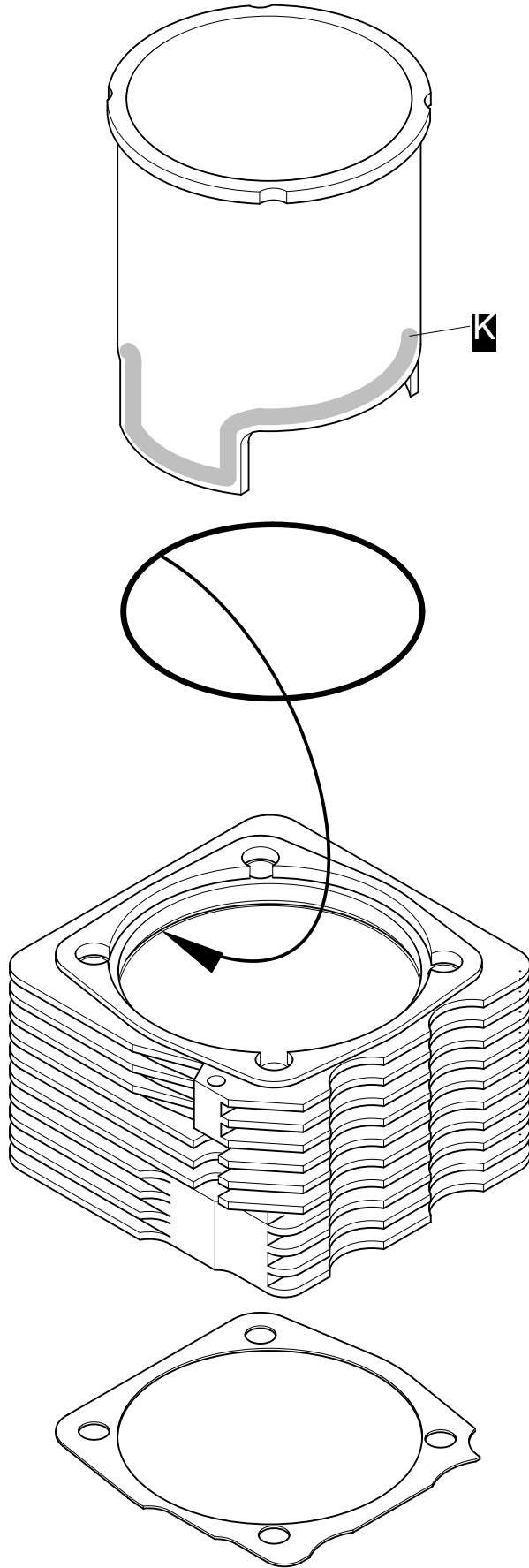

M 07.00 Cylinder head

M 07.10 Rockers and decompression device



General:

The decompression device works due to the fact that the rocker for the exhaust valve is eccentrically supported on the rocker shaft.

The axial fixation of the rocker shaft is executed as follows:

1 D 60 - 80 - 81

by a spring loaded pin (A)

1 D 30 - 31 - 35 - 40 - 41 - 50

by washers and circlips (B).

The radial fixation of the rocker shaft is executed due to an adjustable spring loaded ball stop.

Dismantling:

- Set the engine to T.D.C. firing stroke i.e. both valves closed.
- Unscrew set-screw 1 approx. 3 turns. Remove complete unit 1 only if necessary.
- Remove 2 (A) or 3 (B) (washers during dismantling of rocker shaft) dependant upon type of engine.
- Remove in numerical sequence 4...5.
- Dismantle rocker arm 5 in numerical sequence 6...10.
- Pin 11 remains as part of rocker arm.

Inspection / repair:

- Check all parts, especially the ratchet system, for function, wear or any other damage. Ensure proper function of snap in and releasing of catch 7 and holding spring 9.

Assembly:

- Pre-assemble rocker arm 5 in reverse sequence 10...6.
- Place rocker arms 5.
- Insert rocker shaft 4

- Place 2 (A) or 3 (B) (washers during assembling of rocker shaft) dependant upon type of engine.
- Screw set-screw 1 firmly in until locked. Ensure correct positioning of ball lock in rocker shaft
- Unscrew set-screw 1 180° and check the system for free, but not loose movement.
- Adjust tappet clearance and check decompression device for function.

NOTE:

The ratchet wheels 8 are different and are fitted as follows:

8 ratchet wheel - standard engine as from the start of production.

5 ratchet wheel - since middle of 1992,

1 ratchet wheel - engines equipped with recoil or rope start.

1D31 / 41 from Serial 13, 1D50,

1D60 from Serial 21,

1D81 from Serial 14 und 1D90:

The rocker shaft and cylinder head were modified. The new rocker shafts (with one O-ring only) do not fit in the old versions and vice versa.

1D60 / 81 / 90: axial fixation was modified from former spring-loaded-pin to a hollow pin acting as an oil pressure throttle same time.

Tappet clearance:

Type	Inlet	Outlet
	(mm)	(mm)
1D30 - 81	0.1+0.05	0.2+0.05
1D41	0.2+0.05	0.2+0.05
1D90	0.3+0.05	0.3+0.05

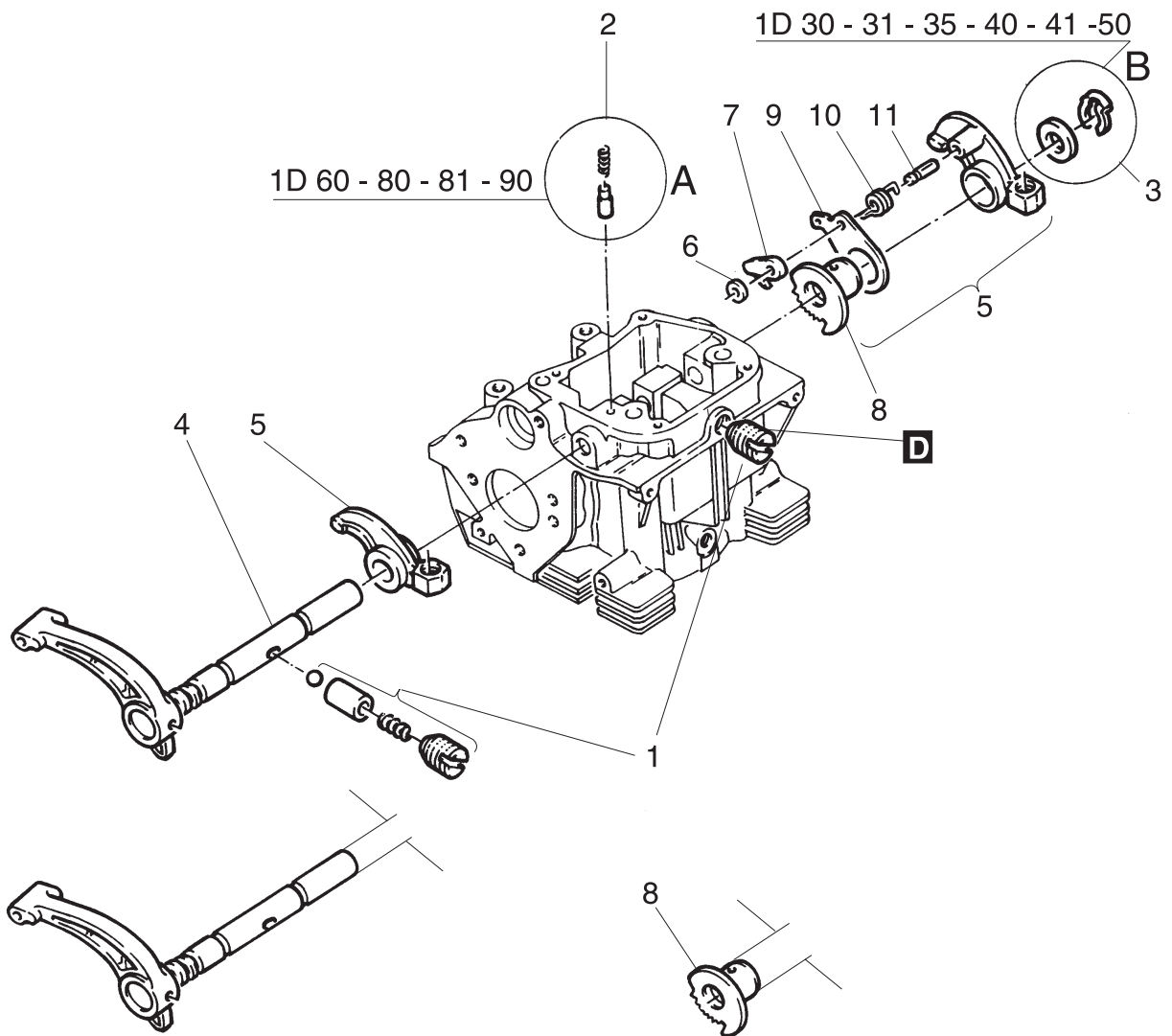

nom. \varnothing 12 $\begin{matrix} -0.006 \\ -0.017 \end{matrix}$
 min. \varnothing 11.93

nom. \varnothing 17 $\begin{matrix} -0.006 \\ -0.024 \end{matrix}$
 min. \varnothing 16.93

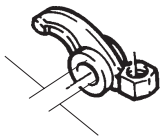

nom. \varnothing 12 $\begin{matrix} +0.034 \\ +0.016 \end{matrix}$
 max. \varnothing 12.13

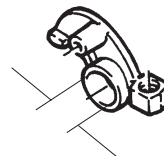

nom. \varnothing 17 $\begin{matrix} +0.018 \\ 0.0 \end{matrix}$
 max. \varnothing 17.5

M 07.00 Cylinder head

M 07.20 Bumping clearance



General:

The bumping clearance has to be checked and re-set after any replacement of a cylinder, piston, conrod, crankshaft or crankcase and with the engine cold.

Bumping clearance to small:

Damage to piston, cylinder head and valves.

Bumping clearance to big:

Engine loses power and starting ability.

Preparations:

Ref.: M-Disassembly cross reference scheme.

Settings:

- Put any of the gaskets and a depth gauge on top of the cylinder and hold cylinder firmly down.
When measuring put the depth gauge as close as possible to the centre of the piston or at least to the centre of the gudgeon pin to avoid any incorrect readings due to tilting of the piston.
- Crank engine until piston has passed T.D.C. position.
- Read correct bumping clearance, by using the correct thickness of gasket to obtain the correct measurement **S** as specified.
Use one gasket only !

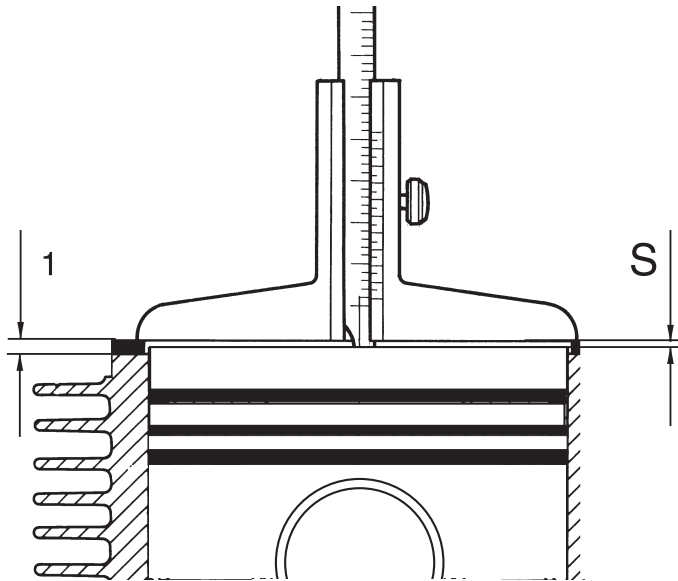

Type	S (mm)
1D30 - 80	0.65 - 0.75
1D41 / 50	0.60 - 0.65
1D81	0.75 - 0.80
1D90	0.80 - 0.85

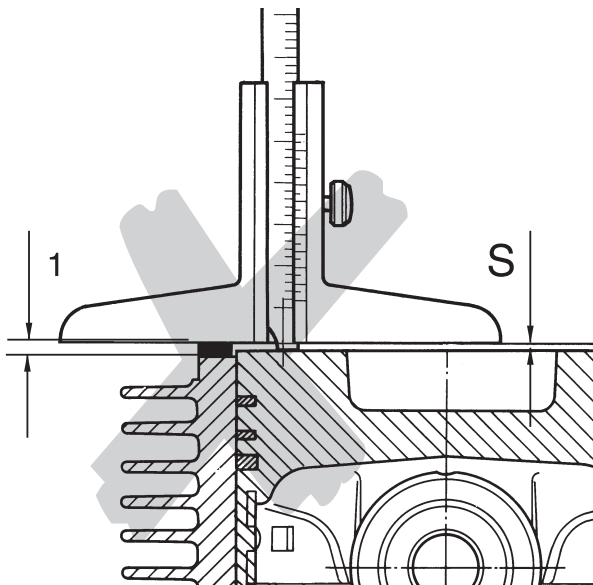

M 07.00 Cylinder head

M 07.30 Cyl.-head and oil supply pipe

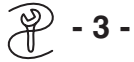

General:

1 D 60 - 80 only !

Due to variations in the depth of the steel anchors in the crankcase in connection with thread reach certain engines have thinner washers fitted to the crankcase front side.

It is of utmost importance to have the correct type washers fitted in the same position as fitted ex-factory !

Preparations:

Ref.: M-Disassembly cross reference scheme.

Dismantling:

- Remove rocker shaft and rockers.
1 D 30 - 31 - 35 - 40 - 41 - 50 only !
- Release and move circlips on protection tubes for approx. 30 mm towards cyl.-head.
- Unscrew cyl.-head screws **1** crosswise and uniformly.
- Remove cyl.-head **3** together with oil pressure pipe **4**.
Be careful that the cyl.head screw seals are not lost or become misplaced.

Inspection / repair:

- Check cyl.-head for broken cooling fins, cracks or any other damage.
- Check valves for possible leakage.
- Check oil press.-pipe for free oil passage.

Assembly:

- Replace cyl.-head screw seals (M 01.50)
- Retain cyl.-head gasket into cyl.-head, using some grease.
Use one gasket only !
- Place pre-assembled oil pressure pipe **4** (spring side) into corresponding bore in cyl.-head.
- Put cyl.-head together with oil pressure pipe carefully onto cylinder, respectively into bore in crankcase.
Ensure oil pressure pipe is properly seated in the bore in crankcase !
- Place cyl.-head screws **1** with washers **2** as specified respectively fitted ex-factory. Apply high-temp. lub.-grease as specified!
- Pre-tighten cyl.-head screws **1** crosswise and uniformly.
- Line cyl.-head up to the best possible vertical line up in connection with the cylinder.
- Tighten cyl.-head crosswise and uniformly step by step.
Torque to specification !
- Finish assembly of protection tubes.
- Finish assembly of rockers and rocker shaft.
- Adjust tappet clearance and check de-compression device for function.

	Nm	lb ft
1D30-31-35-40-41-50	50	37
1D60-80-81-90	80	59

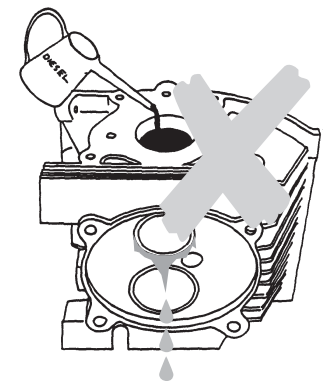
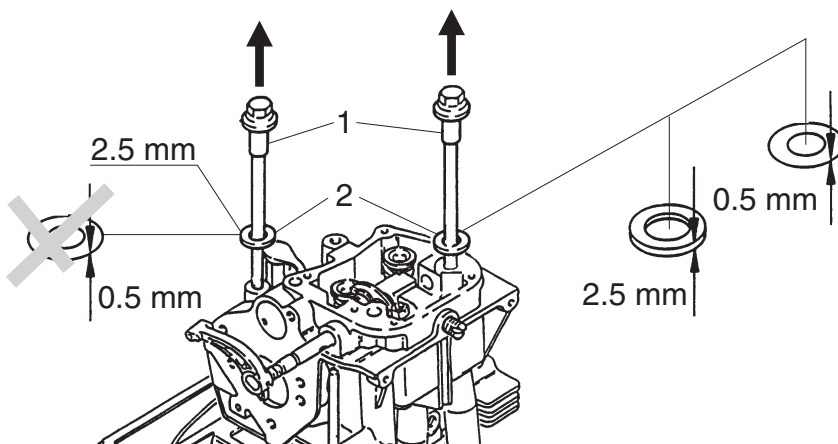
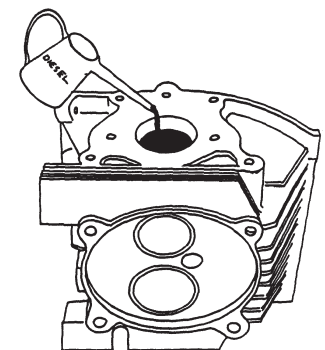
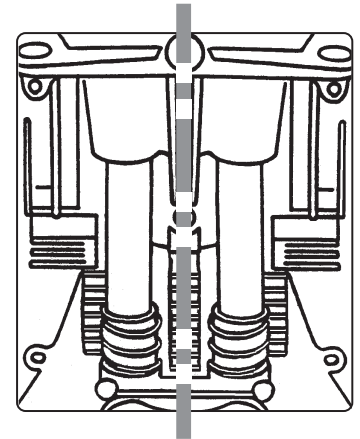
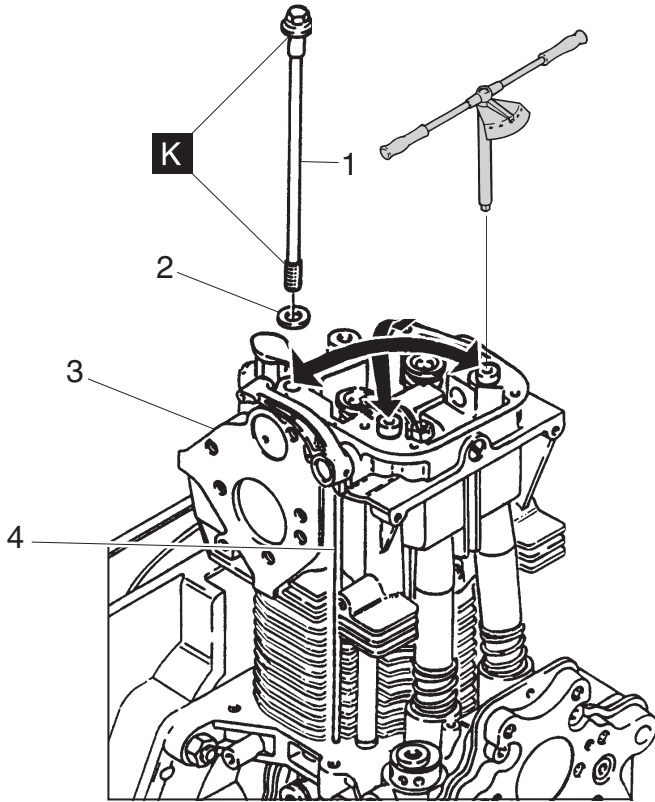
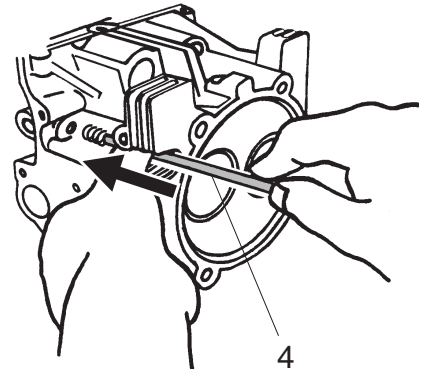

M 07.00 Cylinder head

M 07.40 Valves, valve guides and valve seats

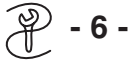

Dismantling:

- Remove valve collets, spring cup, valve spring, spring retainer and valve stem seal cap if fitted.

For removal use tool - 6 -

Inspection / repair:

- Check all parts in question for wear or any other damage like cyl.-head cracks etc. especially for the following conditions:

Valve recession

- After re-installing the valves check the valve recession as specified.
Whenever the recession is close, or slightly above the limits, the bumping clearance should be adjusted to the minimum tolerance to at least partly compensate for the loss of compression ratio.

Radial play of valves

- Lift valves approximately 10 mm off its seat.
- Measure and compare dimensions with dimensions „k“ as specified.
If these figures are exceeded, the valves as well as the valve guides have to be checked separately and/or replaced in case the dimensions „h“ as specified are exceeded.

Valve guide replacement

If possible warm cyl.-head up to approximately 80°C / 175°F.

- Remove (press out) worn valve guides.
- Fit new valve guides.
Ensure correct protrusion „h“ as specified !
- Finish - ream valve guide bore.

Assembly:

- Assemble in reverse sequence valve stem seal cap, spring retainer, valve spring, spring cup and valve collets.
For assembly use tools - 6 -
Ensure proper seating of valve collets !

NOTE:

Valve guides with collar require automatically valve stem seal caps.

Valve recession

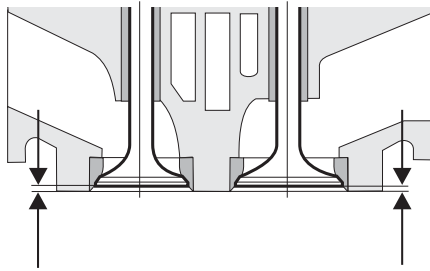

Type	nom. (mm)	max (mm)
1D30-35-40 60-80	0.90 -1.45	1.80
1D31/41	0.60±0.1	1.00
1D50	1.00±0.1	1.40
1D81/90	0±0.1	0.40
D41/50 EPA II	-0.60±0.1	-0.20

Radial play of valves

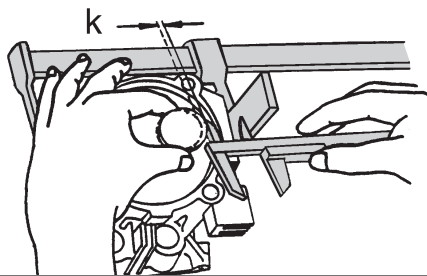

		k nom.	k max.
1D30-31-35-40-41-50	mm	0.08 - 0.12	0.3
1D60-80-81-90	mm	0.10 - 0.15	0.4

Wear of valve guide

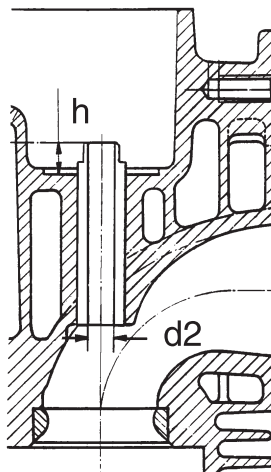

Valve guides **without recess** for the valve stem seal cap

		1D30-31-35-40-41-50	1D60-80-81-90
h	mm	7.7 - 8.0	13.2 - 13.5

Valve guides **with recess** for the valve stem seal cap

h	mm	3.2 - 3.5	8.2 - 8.5
---	----	-----------	-----------

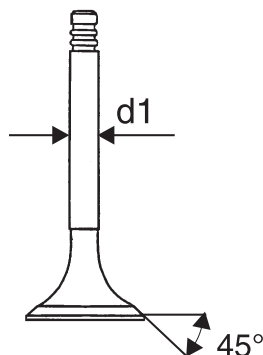

		1D30-31-35-40-41-50 mm	1D60-80-81-90 mm
In.	d1 nom.	6.95 - 6.96	7.95 - 7.96
	d1 min.	6.94	7.94
Ex.	d1 nom.	6.96 - 6.97	7.96 - 7.97
	d1 min.	6.95	7.95
	d2 nom.	7.00 - 7.01	8.00 - 8.01
	d2 min.	7.03	8.04

M 08.00 Cover for cylinder head



General:

There are engines with different breather systems in the field which are entirely different from one another.

It is of utmost importance not to change the system as fitted ex-factory to avoid either blue smoke, high oil consumption or instability of engine speed.

Version I

Breather orifice as indicated, breather system internal.

Version II

Breather orifice as indicated, breather system internal.

Version III

Breather orifice as indicated, breather system external.

Dismantling:

– Remove in numerical sequence **1...4**.

Inspection / repair:

– Check sealing surface for any damage.

Assembly:

– Assemble in reverse sequence **4...1**.

Tighten Allen screws crosswise and uniformly.

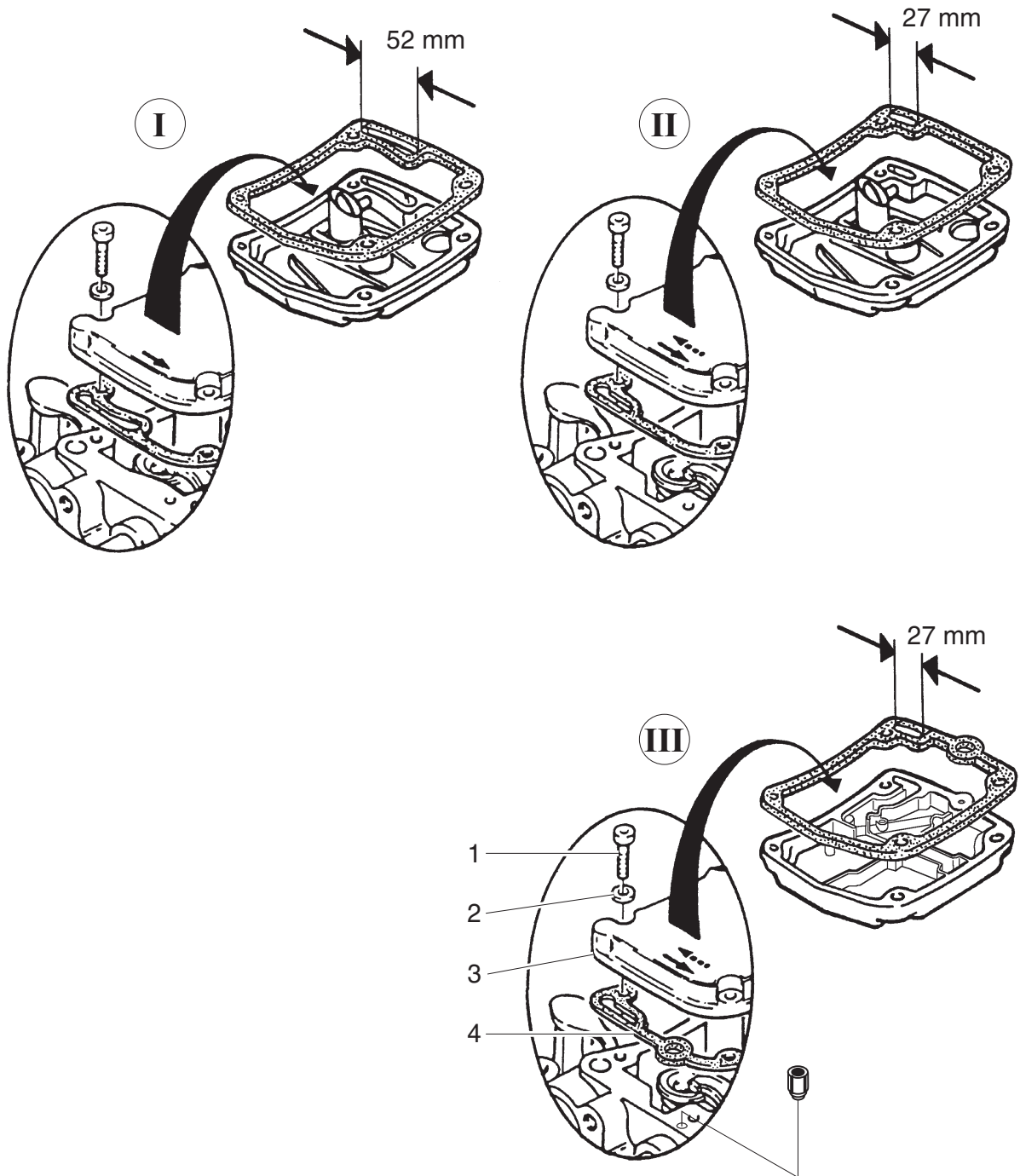

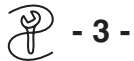

General:

Pushrod tubes can be removed to replace the „O“-Rings in case of any oil leaks without removing the cylinder head.

Dismantling:

- Remove rocker shaft and rockers.
- Remove pushrods **1**.
- Release and move circlip **6** approx. 30 mm toward cyl.-head.
- Press pushrod tube unit **2** firmly down and remove (tilt) complete unit out of its seat position in cyl.-head.

The complete unit **2** may remain pre-assembled, respectively dismantled if necessary.

Inspection / repair:

- Check circlips for possible overstretching.
- Check pushrod caps for wear, seating or any other damage.

Assembly:

- Prepare pre-assembled protection tube **2**
Retaining ring **4** slightly V-shaped, convex side facing cyl.-head.
- Slide pre-assembled protection tubes firmly back into position, starting first at crankcase bore.
- Locate and fix protection tubes in the upper position in the cyl.-head.
For assembly use tool - **3** -
- Force i.e. press circlip **6** against spring load firmly down into final position in ring groove.
For assembly use open end wrench.
- Re-insert pushrods **1**.
Ensure proper position of pushrods in cam followers !
- Finish assembly.

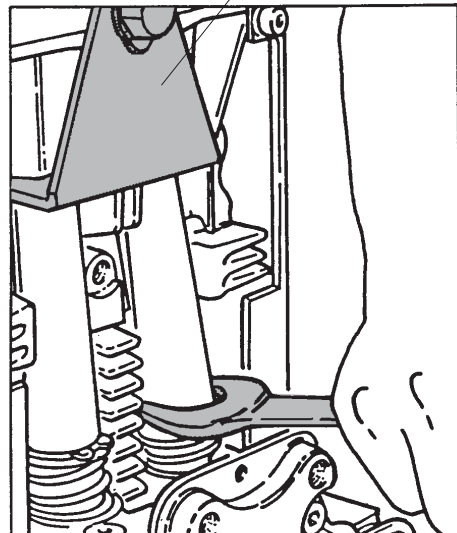
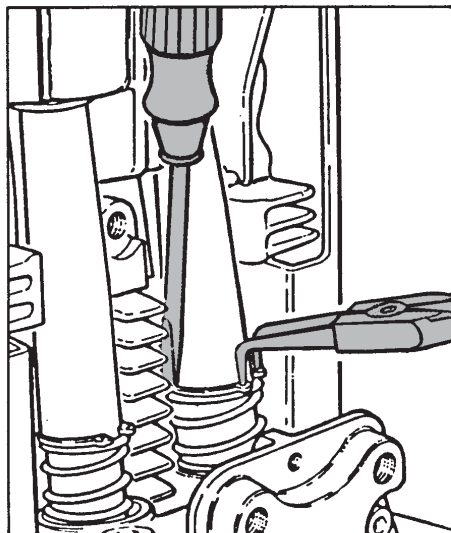
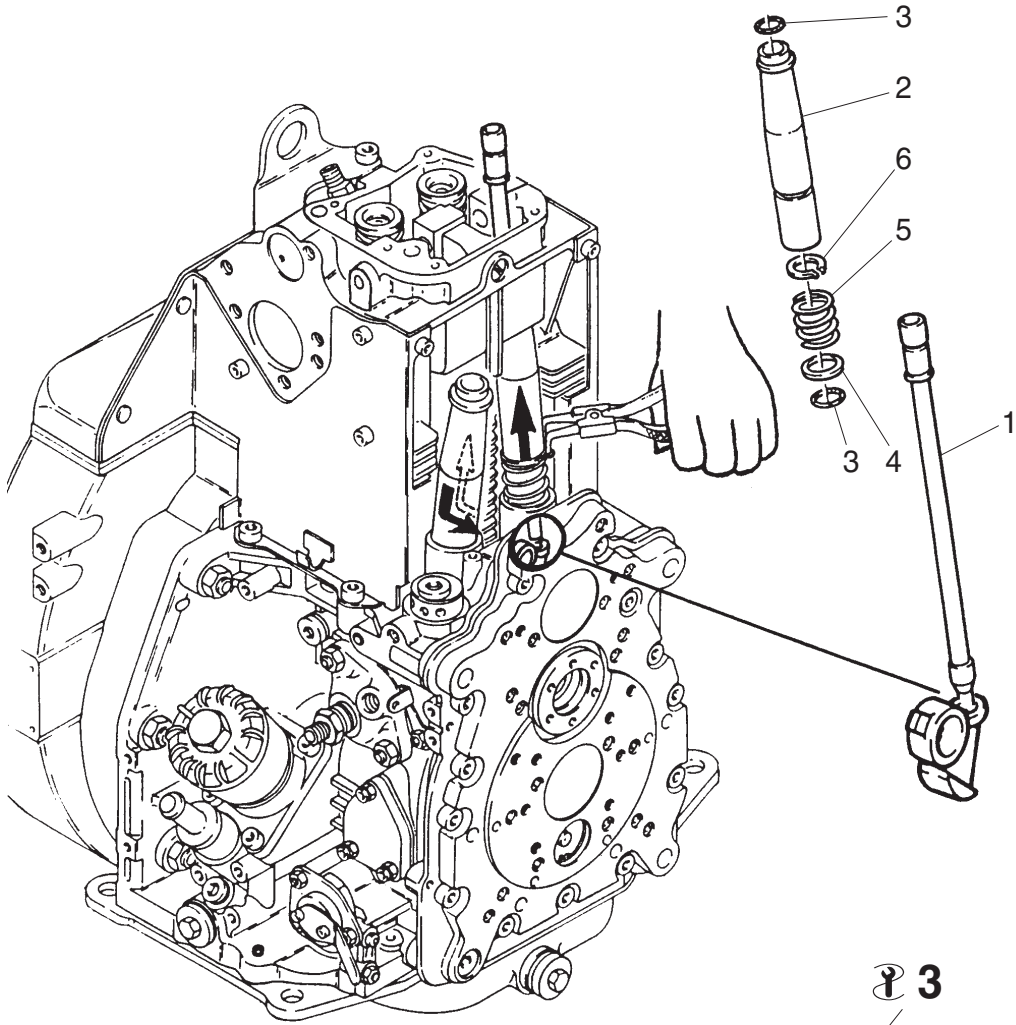

3

M 10.00 Oil pump / Governor

 - 4 - 15 - 16 -

General:

The oil pump-governor assembly is built as a unit and fitted inside the timing cover. Governor springs can be replaced without removal of timing cover. For replacement remove front closing cover only.

Dismantling:

- Remove in numerical sequence **1...3**. For removal use tool - **16** -
- Remove complete oil pump-governor unit **4** and drive gear **17** from timing cover.
- Prestress governor springs **8**. Use tool - **4** -
- Remove in numerical sequence **5...6**. Shims **6** if so fitted.
- Remove tool - **4** -
- Remove in numerical sequence **7...11**.
- Remove (press) oil pump gearwheel **12** from spring housing **13**. Use suitable tool.
- Remove (press) governor weight carrier **14** from spring housing **13** if necessary.

Inspection / repair:

- Check all parts, including timing cover, for wear or any other damage. It is of utmost importance to replace all parts showing burrs or axial and radial surface wear in connection with either oil pump or governor system.

Assembly:

- Pre-assemble (press) in reverse sequence **13...12** to position as specified. For assembly use tool - **15** -
- Place oil pump gearwheel unit **13/12** through the cover **16** and housing **15** onto governor weight carrier **14**. Ensure correct position (90° offset) be-

tween marks on spring housing **13** and weight carrier **14** as specified.

- Press weight carrier **14** firmly onto gearwheel unit **13/12** (flush) as specified.
- Install (hook) governor weights **11** into corresponding roll pin location inside the weight carrier **14**.
- Assemble in reverse sequence **10...9**. Ensure free movement of pin **9** !
- Assemble in reverse sequence **8...7**.
- Prestress governor springs **8** to assemble circlip **5**. Use tool - **4** -
- Check and adjust if necessary by using shims **6** the clearance „S“ (ref. Chapter 4)
- Place and position drive gear **17** into timing cover.
- Turn weight carrier **14** to horizontal position.
- Assemble complete unit **4** carefully onto timing cover. Ensure correct positioning of gears before assembly !

from Serial:

1D30.15, 1D31.12, 1D40.16, 1D41.12, 1D50.10, 1D60.22, 1D80.21, 1D81.15 1D90.10 und 1D90V.10

The oil pump was improved (gear height on **12** and **17** was changed from 7.5 mm to 9.5 mm)

The following components are affected by this modification: crank shaft gear, oil pressure relief valve and bearing bush in timing cover.

Attention!

The mentioned parts are not interchangeable with former ones!

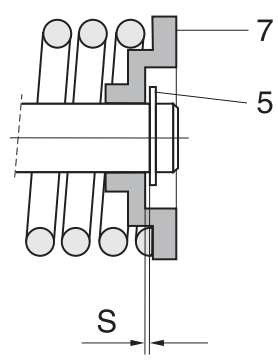
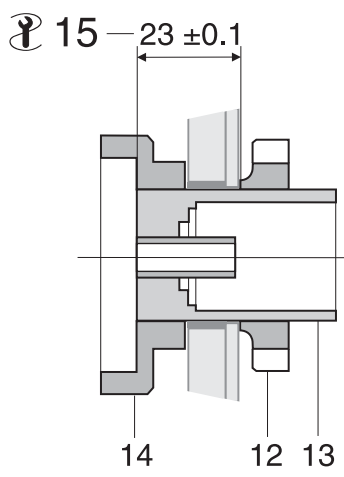
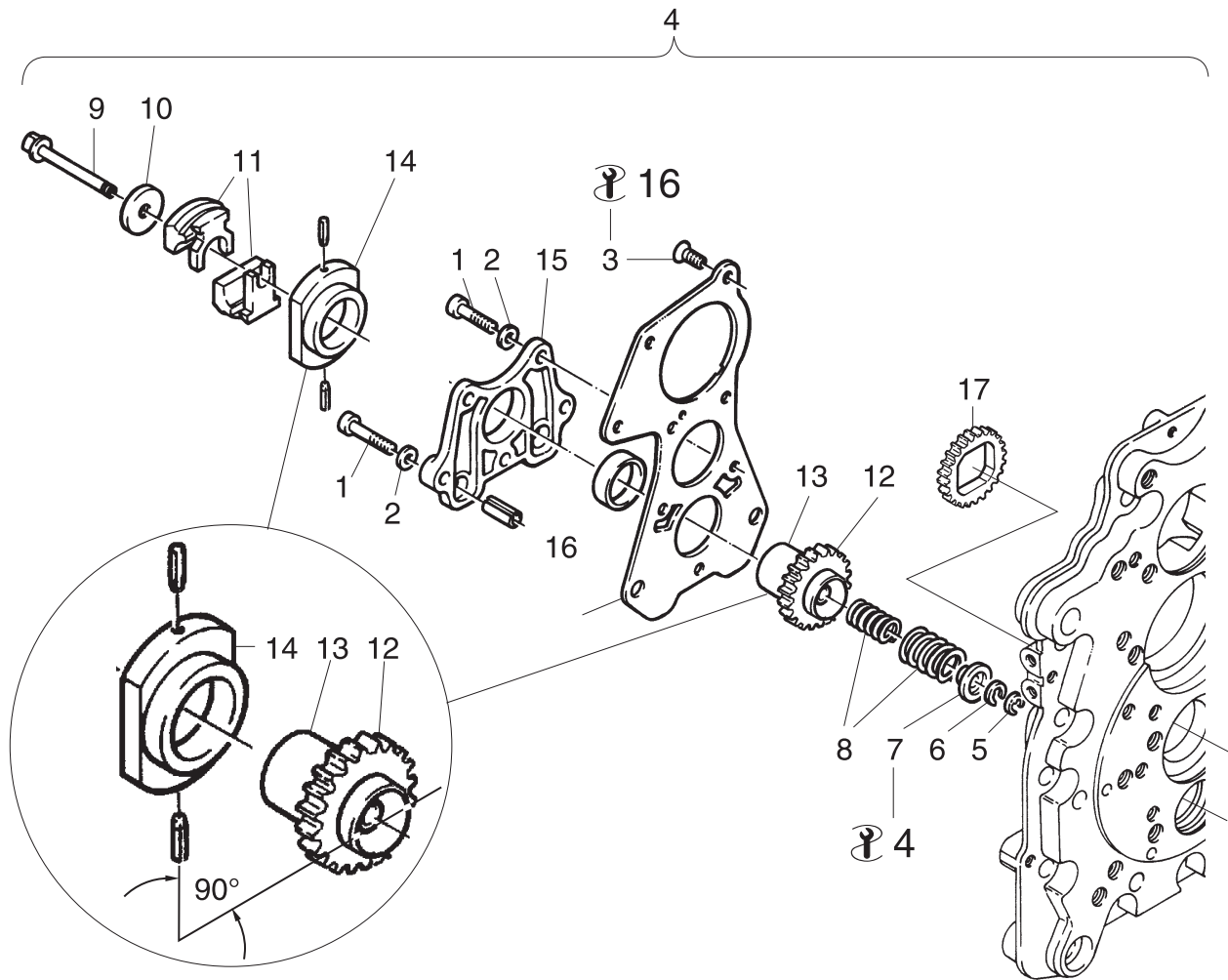

M 11.00 Timing cover

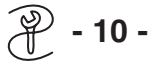

General:

Timing covers in connection with oil galleries have been modified during production.

Version I

The oil gallery, i.e. the oil supply to the camshaft bearing, is fully cast-in.

Version II

The oil galleries, i.e. the oil supply to the camshaft bearing, are milled as open channels and therefore covered by a new constructed oil pump cover.

Note:

Clock-wise engines (version T/U) are equipped with an additional oil spray nozzle in the timing cover. It points to the middle of the camshaft bearing bore (view to inside of timing cover).

Dismantling:

- Remove in numerical sequence **1...4**.
- Turn engine until the visible marks on the spring housing inside the closing cover **4** are in a vertical direction to obtain the best possible position for dismantling.
- Remove complete timing cover **5**.
If necessary remove oil pump-governor unit. (ref. M 10.00)

Inspection / repair:

- Check all parts in question for wear or any other damage.
- If necessary remove and replace bearing bushing **6**.
- For removal and assembly use tool - **10** - .
Make sure lubrication passages align.
- If necessary remove and replace remaining bearing bushings too.
A setback of 0.1 - 0.2 mm against bushing flush has to be obtained.

Assembly:

- Pre-assemble timing cover/oil pump-governor unit **5**. (ref. M 10.00)

It is of utmost importance to observe the width of the cover for the oil pump in accordance to the Versions as specified.

Oil pump cover **Version I: A** ≈ 56 mm

Remains in connection with timing cover Version I (cast-in oil galleries) only.

Oil pump cover **Version II: A** ≈ 68 mm

Replacement for cover Version I i.e. fully interchangeable.

NOTE:

Under no circumstances may a cover Version I be used for Version II as this results in no oil supply at all!

- Turn engine until the crankshaft gear-wheel is in position as specified.
- Bring governor weight carrier and drive gear into position as specified to obtain the best possible position for assembly.
- Assemble in reverse sequence **5...1**.
Apply sealant and locking agent as specified !
Tighten Allen screws crosswise and uniformly.

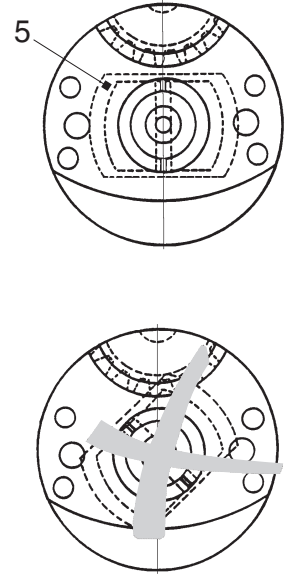
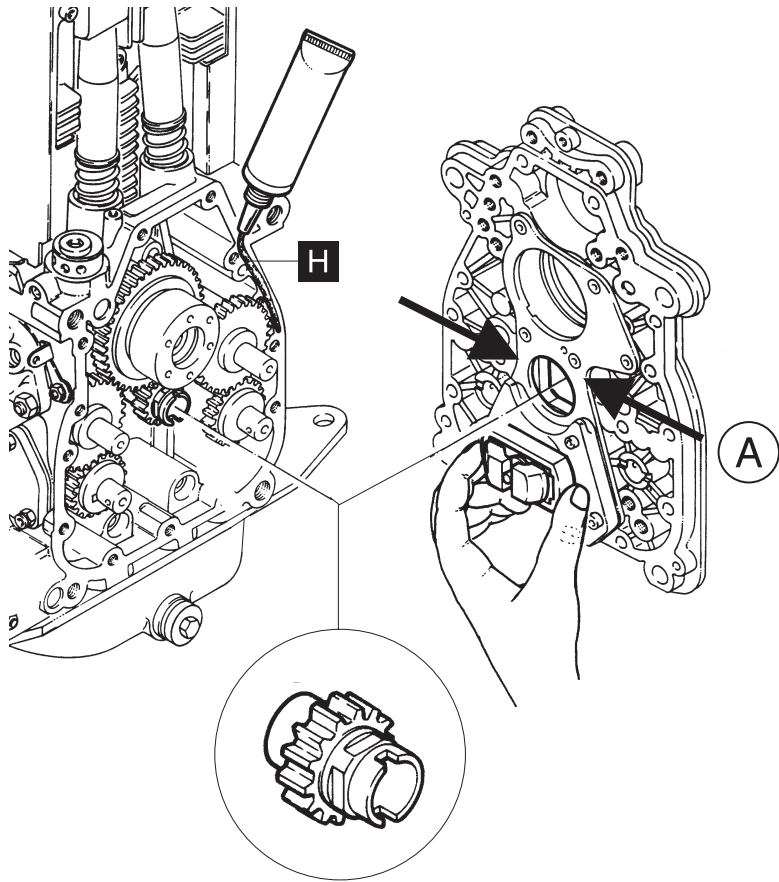
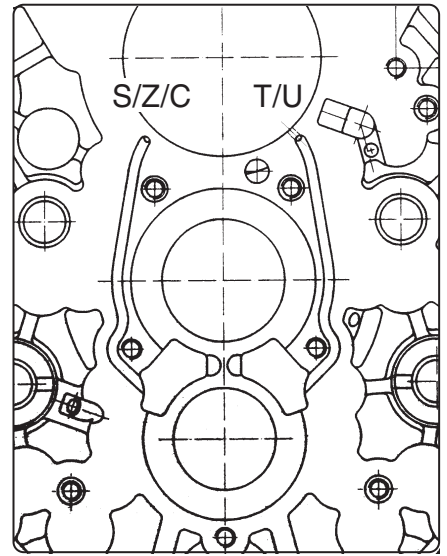
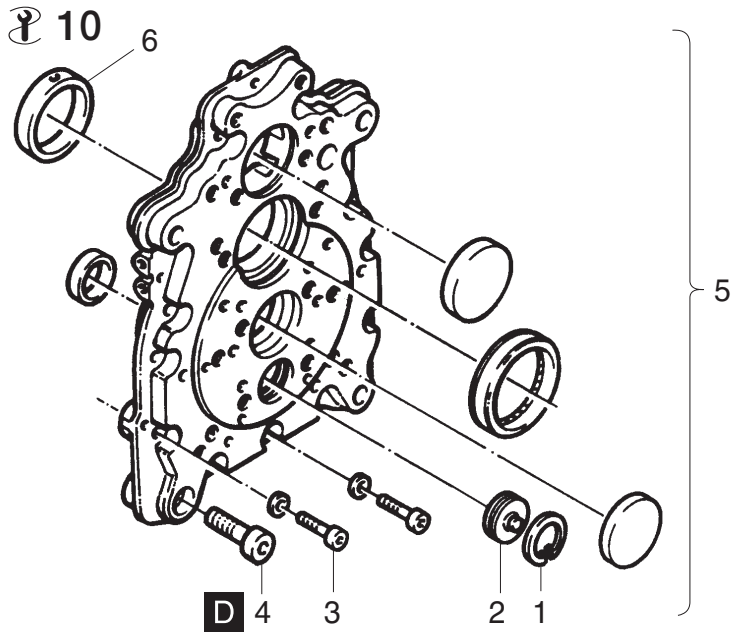



General:

The adjustment of fuel quantity injected in accordance with power output is done by turning the body part **7**.

Therefore remove complete extra fuel device only in case of a major overhaul i.e. the device **2**, at least the body **7**, should remain if possible.

NOTE:

Removal of complete extra fuel device requires re-adjustment of fuel setting.

I. Standard extra fuel device

Function

Engine at stand-still (no oil pressure) means the fuel limit stop pin is in open position i.e. extra fuel position **(A)**.

Engine in operation (oil pressure) means the fuel limit stop pin is in position to limit the quantity of fuel injected in accordance with power output etc. **(B)**.

Preparations:

Ref.:M-Disassembly cross reference scheme.

Dismantling:

- Mark position of extra fuel device on crankcase for positioning in case body part **7** moves during disassembly.
- Remove in numerical sequence **3...6**. Hold body part **7** tight to avoid any movement during removal of closing screw **3**. Grub screw **1** remains tight. Screw **3** has Loctite applied. Slight heating of screw **3** softens Loctite for easier removal.

Inspection / repair:

- Check parts for wear or any other damage.

Assembly:

- Reverse in numerical sequence **6...3**. Apply locking agent as specified!
- Hold body part **7** tight to avoid any movement during assembly of closing screw **3**. For pre-adjustment place extra fuel device in such a way that the grub screw and the middle position of the four bores for adjustment line up.

II. Thermally activated extra fuel device Function

Identified by „T“ stamped on body **7**.

A temperature controlled pin is fitted instead of the standard pin **5**.

Engine at stand-still (no oil pressure) means the fuel limit stop pin is in open position i.e. excess fuel position **(A)**.

Engine in operation, oil pressure moves pin downwards.

Oil temperature below 45°C/113°F:

A bimetal spring limits travel of pin **5** and the governor lever is still in a position to inject more fuel than in the full-load position **(B)**.

Oil temperature above 45°C/113°F:

Bimetal spring retracts and pin drops down to normal full-load position **(C)**.

Dismantling / Assembly:

Ref.: Standard version.

Inspection / repair:

- Check parts for wear or any other damage.
- Measure distance between top edge of body part and pin as specified. For any further advice contact your nearest HATZ-Distributor.

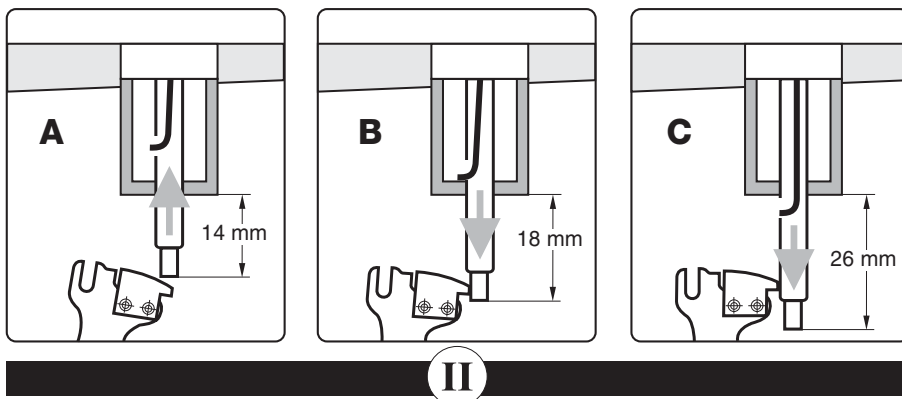
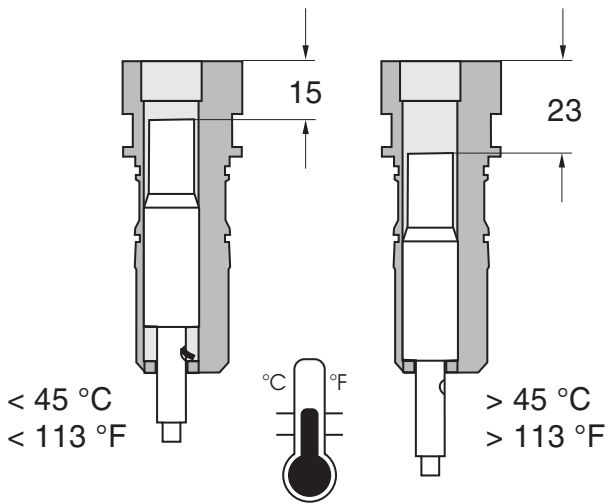
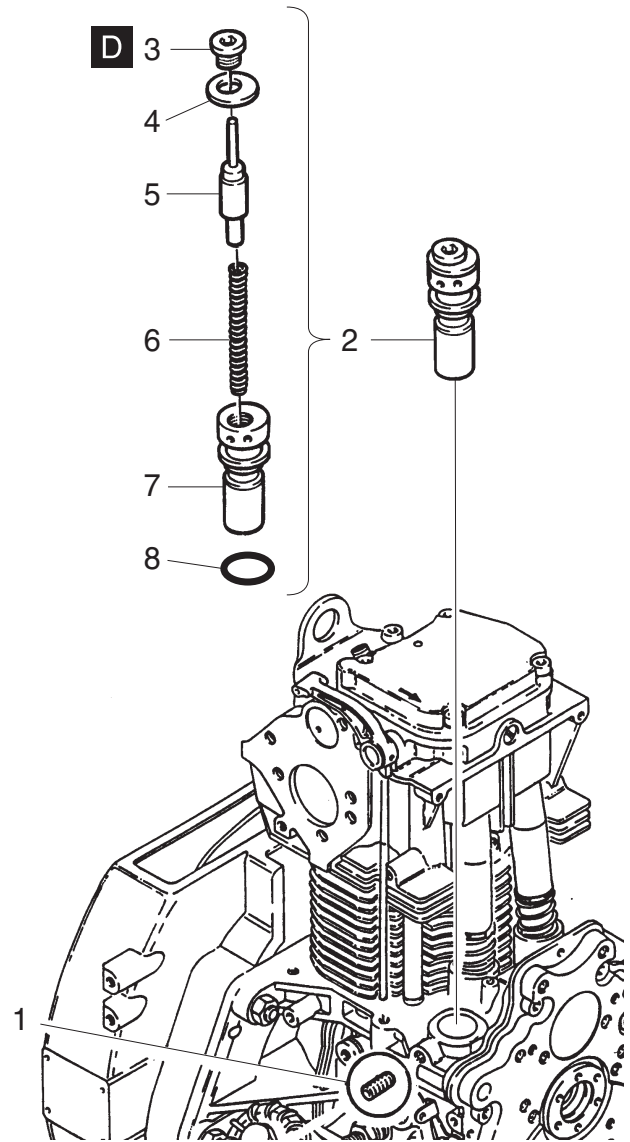
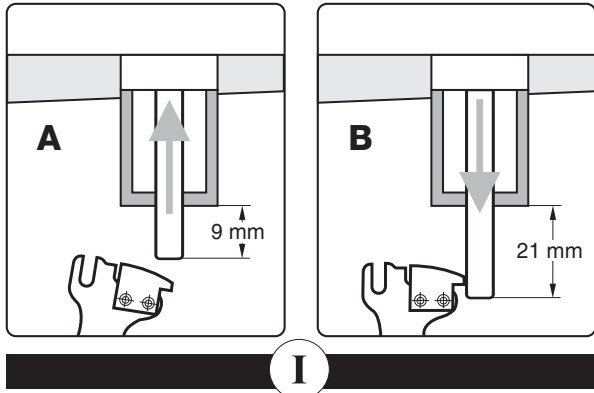

M 14.00 Fuel-injection equipment

M 14.10 Fuel pressure pipe



Preparations:

Ref.: M-Disassembly cross reference scheme.

Dismantling:

–Unscrew union nuts **1** and remove fuel pressure pipe with rubber bushing **3**.

NOTE:

Ensure connector **2** remains tight during removal of fuel pressure pipe.

Always use a wrench to hold connector **2** tight during disassembly of fuel pressure pipe !

Inspection / repair:

- Check for fractures or chafing.
- Check conditions of sealing surfaces.
Replace if any evidence of damage!

Assembly:

- Place and pre-tighten (fingertight) fuel pressure pipe without strain.
Ensure rubber bushing **3** is in position of the clip **4**.
- Tighten union nuts **1**.
Hold connector **2** with wrench.
Torque to specification!

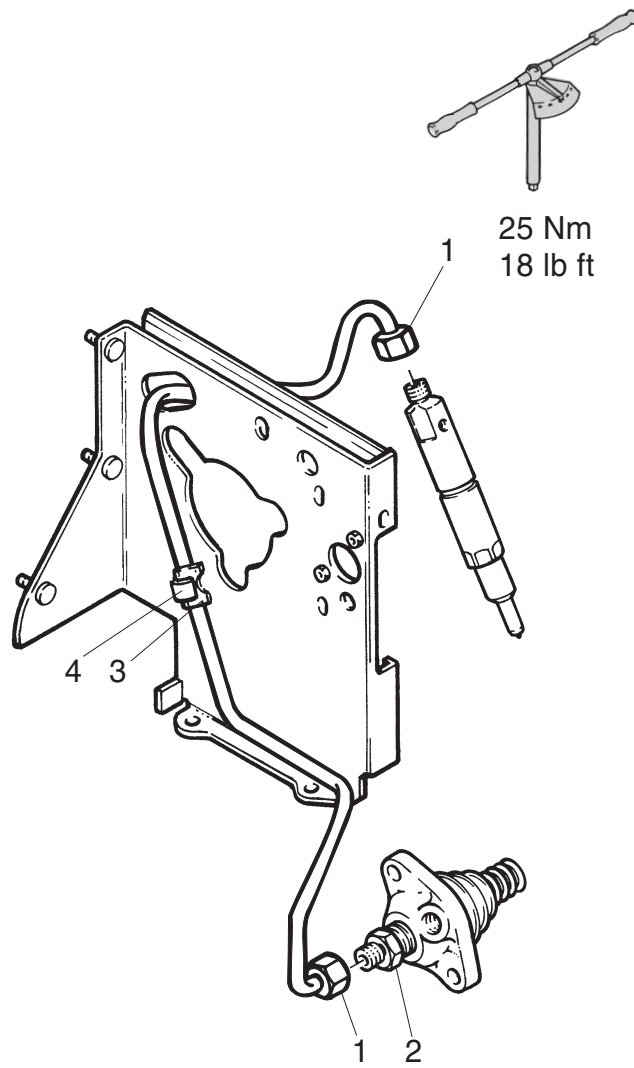

M 14.00 Fuel-injection equipment

M 14.20 Injector

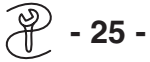

Preparations:

Ref.: M-Disassembly cross reference scheme.

Dismantling:

- Remove in numerical sequence **1...5**.
- Loosen and remove injector **6** by turning or pulling.
For removal use tool - **25** -
- Remove seal ring **7** either from injector or cyl.-head.

Inspection / repair:

- Check nozzle body for overheating or plugged spray holes.
If possible test injector using a nozzle tester or contact your nearest HATZ-Distributor or any other authorized workshop.
- Check injector pressure according to figure as stamped into nozzle-holder body.
- Check spray pattern for proper atomizing.

ATTENTION !

Keep your hands away from the nozzle spray. The jet of a spraying nozzle can cause blood poisoning.

For further repair proceed as follows:

- Dismantle injector **6** in numerical sequence **8...14**.
- Check nozzle **9...9/1** for plugged spray holes, worn nozzle needle (scoring, overheating) and/or any other damage.
Nozzle body and nozzle needle must not be interchanged !

- Clean all parts carefully but do not use hard objects, brushes etc.
Nozzle needle has to slide free by its own weight !
- Assemble in reverse sequence **14...8**.
Torque to specification !
- Check and adjust injection pressure by changing shim **13** if necessary.

Assembly:

- Clean bore in cyl.-head carefully.
- Put seal ring **7** onto injector using some grease.
Always use a new seal ring !
1 D 60 / 1 D 80 only:
The soft, graphite-coated sealing surface must point towards the injector.
- Place injector **6** with seal ring **7** carefully into cyl.-head.
Ensure seal ring **7** remains in position during assembly.
- Assemble in reverse sequence **5...1**.

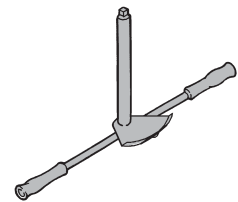
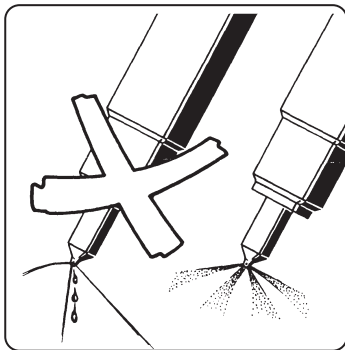
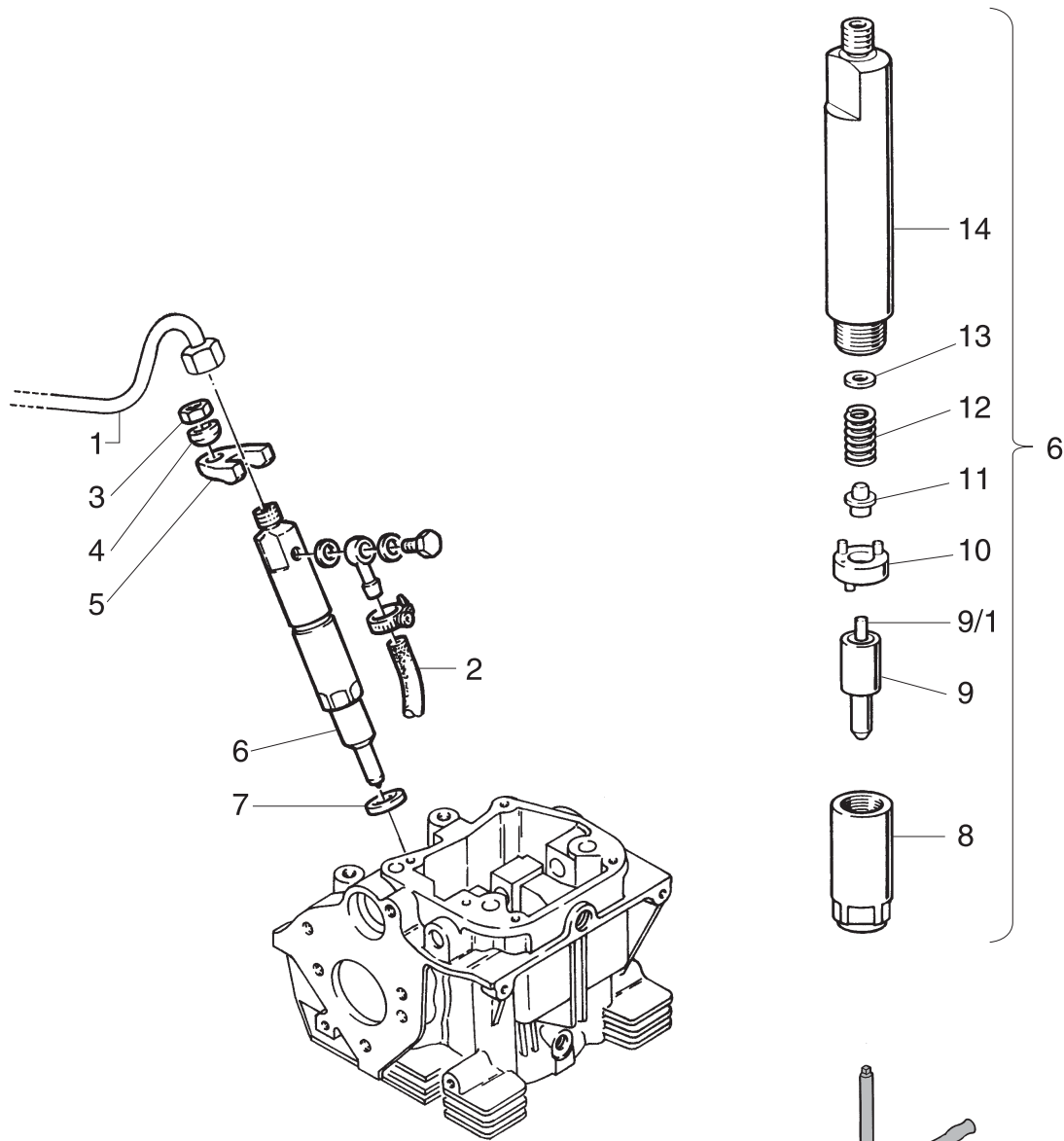

	Nm	lb ft
1D30-31-35-40-41-50-81-90	40 - 50	30 - 37
1D60-80	50 - 70	37 - 52

M 14.00 Fuel-injection equipment

M 14.30 Injection pump



- 28 - 33 -

General:

The replacement of crankcase and / or camshaft requires a mandatory adjustment for timing and fuel quantity.

For any field repair work i.e. replacement of injection pump only, a standard replacement of the injection pump would be within the ex-factory adjusted values as long as no changes in timing (shims) and / or fuel setting (extra fuel device) have been done. Final adjustments require special adjustments in connection with timing and fuel quantity (power setting).

The injection pump shims change the timing. 0.1 mm change in shim thickness changes the timing by approx. 1°.

Shim.-pack (mm)	Gaskets/Paper mm	Shim/Steel (mm)
0.1	0.1	—
0.2	0.2	—
0.3	0.3	—
0.4	0.2 + 0.2	—
0.5	0.3 + 0.2	—
0.6	0.3 + 0.3	—
0.7	0.2 + 0.2	0.3
0.8	0.3 + 0.2	0.3
0.9	0.3 + 0.3	0.3
1.0	0.2 + 0.2	0.6
1.1	0.3 + 0.2	0.6
1.2	0.3 + 0.3	0.6
1.3	0.2 + 0.2	0.9
1.4	0.3 + 0.2	0.9
1.5	0.3 + 0.3	0.9
1.6	0.2 + 0.2	1.2
1.7	0.3 + 0.2	1.2
1.8	0.3 + 0.3	1.2

Preparations:

Ref.: M-Disassembly cross reference scheme.

Functional check:

Before dismantling the injection pump a functional test should be carried out to check the condition in general as follows:

- Remove pressure spring inside of extra fuel device allowing the fuel stop pin to drop into position of normal operation. Ref.: Chapt. M 12.00
- Bring speed control lever to FULL-position.
- Place test nozzle - **28** - onto injection pump.
- Crank engine and check spray pattern for proper atomizing i.e. it is proven that the injection pump (pump element and delivery valve) is in good condition.

ATTENTION:

Keep your hands away from the nozzle spray. The jet of a spraying nozzle can cause blood poisoning.

- After testing remove test nozzle.
- Check timing, use tool - **33** -
- Reassemble extra fuel device.

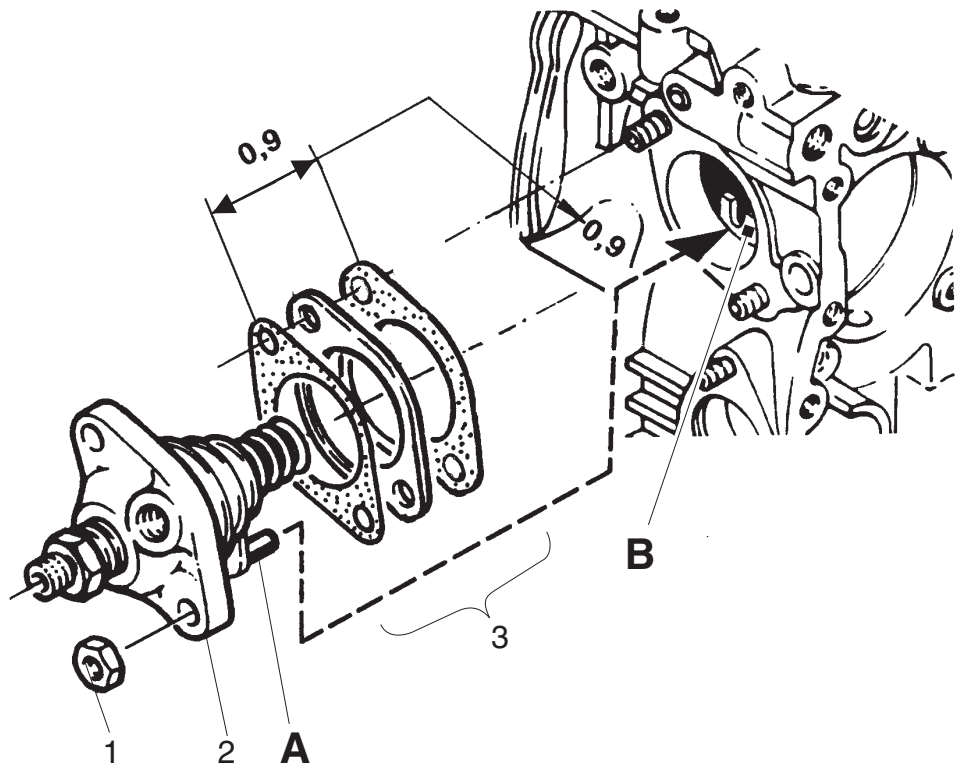
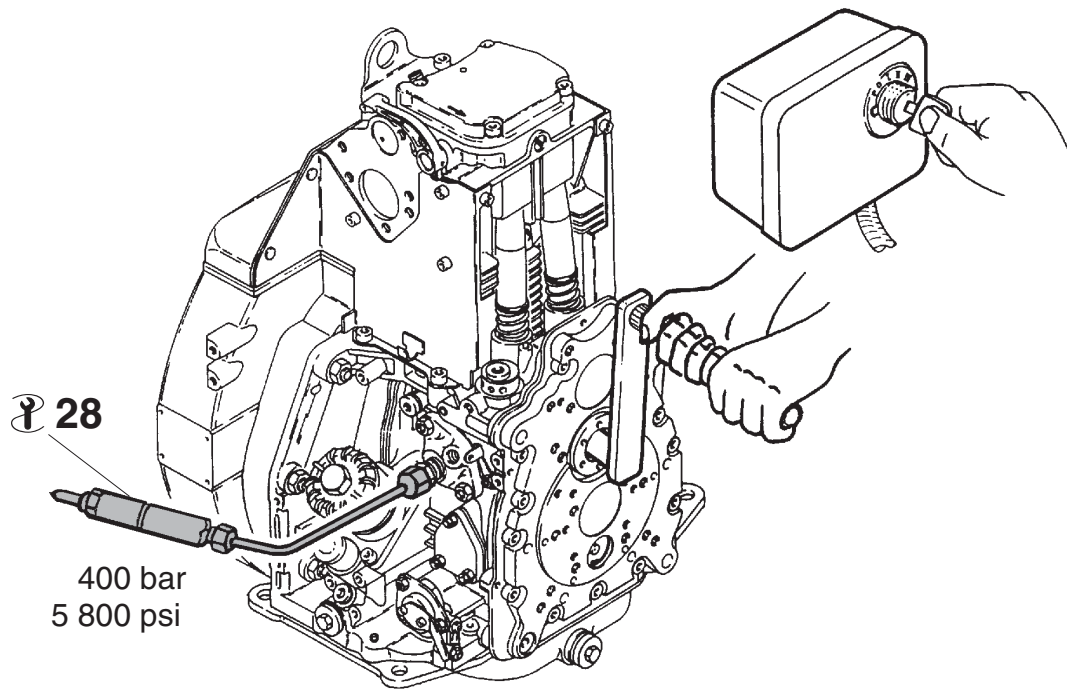

M 14.00 Fuel-injection equipment

M 14.30 Injection pump



Dismantling:

- Remove fuel supply.
- Remove in numerical sequence **1...3**.

Inspection / repair:

- Check control sleeve **A** for free movement.

NOTE:

Repairs in connection with the injection pump should be carried out by a HATZ-Distributor or any other authorized workshop.

Assembly:

- Turn engine until roller tappet reaches the lowest cam position (B.D.C.).
- Bring speed control lever to such a position that the guidance slot of the governor lever **B** is in a center position of the roller tappet bore.
- Use the shim-gasket pack as specified to obtain the value corresponding with the figure stamped into the crankcase.
- Place shim-gasket pack **3** onto crankcase.

No further sealing essential !

- Move control sleeve pin **A** to center position in the recess of the injection pump housing in order to line-up with the governor lever guidance slot **B**.
- Insert injection pump carefully, not moving the control sleeve during assembly. The pump must be inserted to approx. 3 - 4 mm before touching the crankcase without any resistance being felt. At this point the spring is in contact and resistance will be felt. A slight pressure by hand will bring the pump into final position.

NOTE:

It is of utmost importance not to force the injection pump against the governor lever !

Hint: A small amount of „white out“ placed on the pump control sleeve pin **A** will assist you in lining up the pump with the governor lever.

- Hold injection pump tight in its position and install Hex.-nuts.
- Tighten Hex.-nuts **1** uniformly.

Delivery lift and power setting:

Adjustment of delivery lift is done by turning the extra fuel device:

clockwise = lower delivery lift
counter clockwise = higher delivery lift.

Adjustment in connection with a dial gauge and the spill device is possible.

Only qualified diesel technicians should attempt these adjustments because wrong settings may damage the engine.

To undergo a full engine test, operate engine on a dynamometer under actual load conditions measuring exhaust gas temperature as well as speed and power setting while measuring fuel quantity.

Typically only a HATZ-Distributor would have the correct type of equipment to accomplish this.

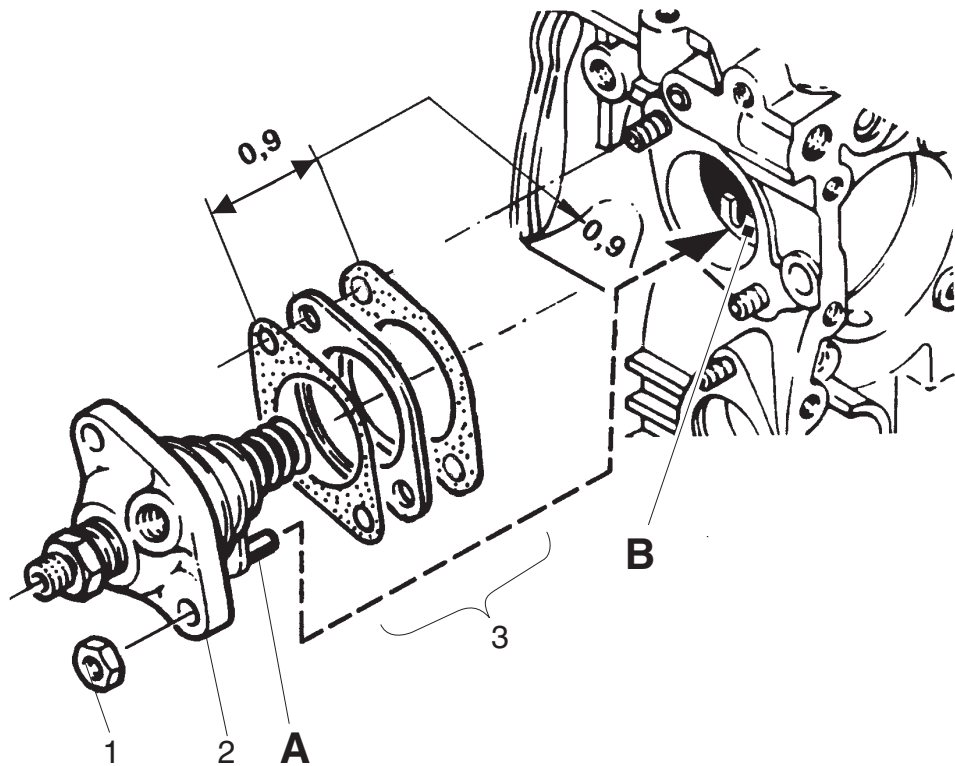
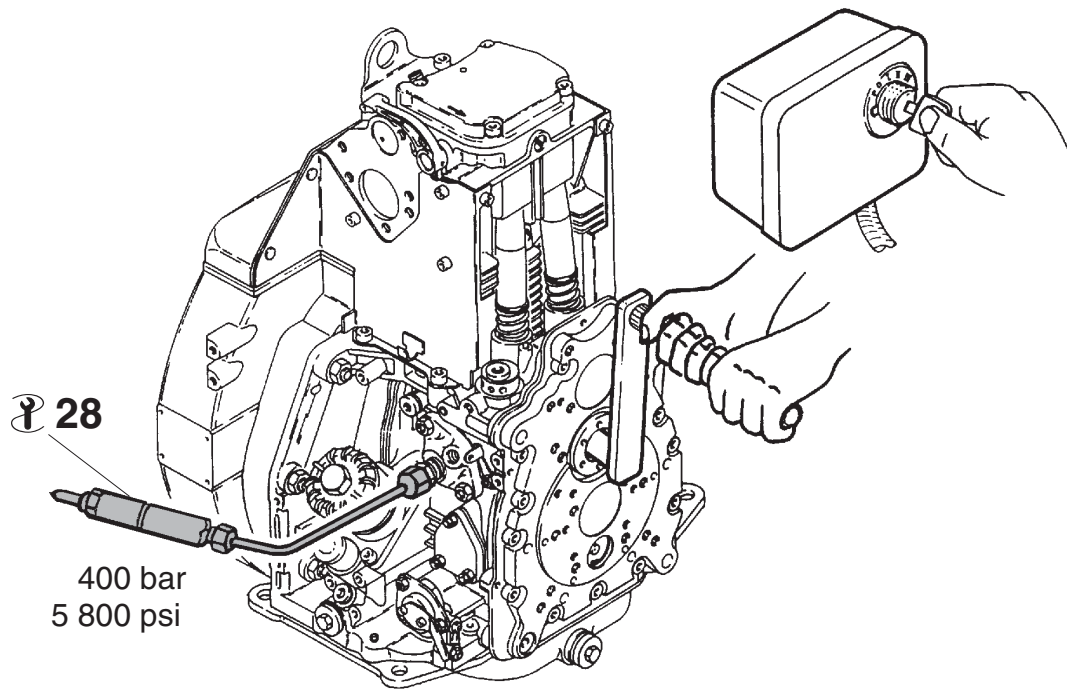

M 14.00 Fuel-injection equipment

M 14.30 Injection pump



- 28 - 33 - 38 - 39 -

“Monoblock” injection pump (EPA II):

From Serial No.:

1D41.21, 1D50.16, 1D81.24, 1D90S/Z.18,
1D90V/W.15

- Add numerical value at the crankcase (in mm, e.g. 1.6) and at the injection pump (in 1/10 mm, e. g. 4)
- Assemble washer package consisting of one steelspacer and respective number of gaskets
- Place package between crankcase and injection pump, pay attention to the correct radial adjustment of the pump (marking on injection pump and on crank case to match)
- The injection pump of EPA II engines is fixed with special nuts and sealed by tamper proof caps.

Please use special tools - **38 - 39** - for this purpose.

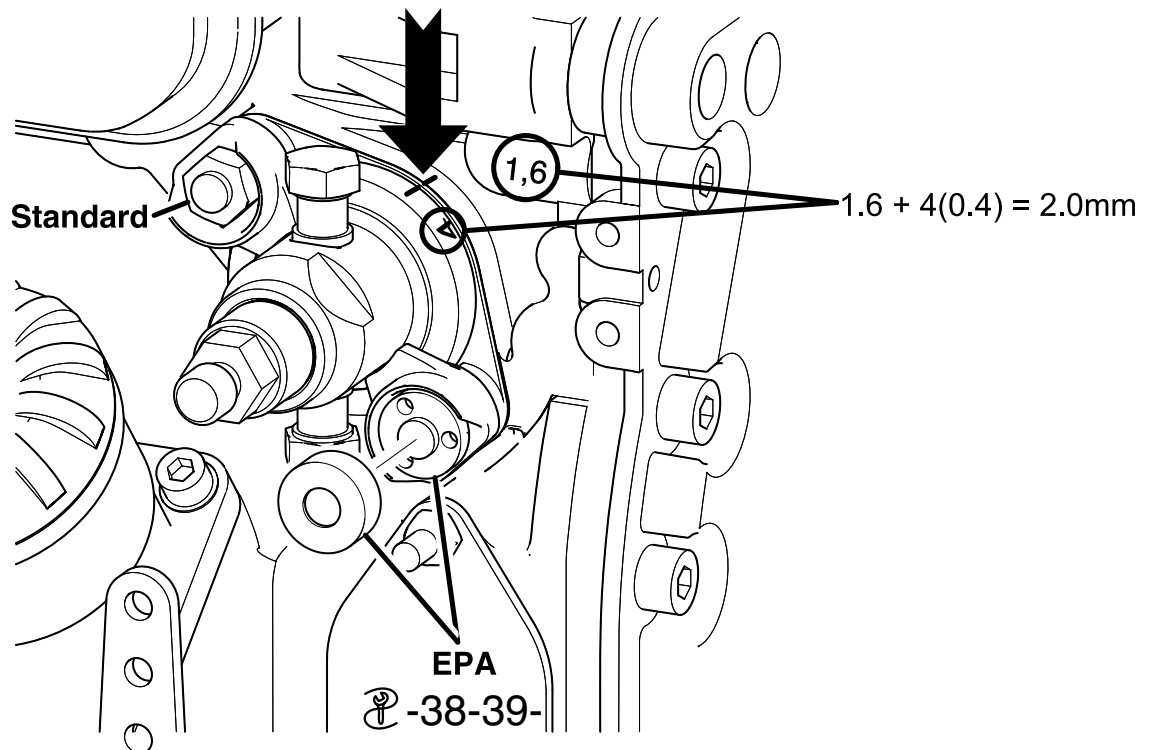
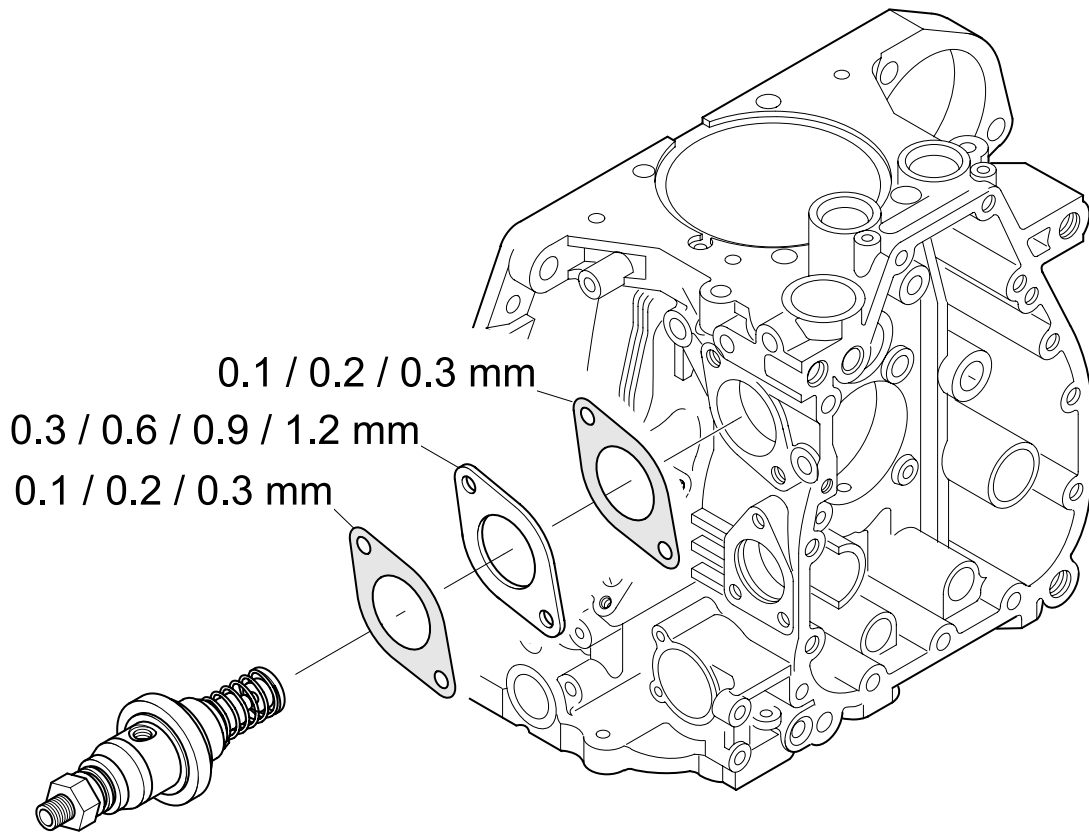

M 14.00 Fuel-injection equipment

M 14.40 Roller tappet



Preparations:

Ref.: M-Disassembly cross reference scheme.

Dismantling:

- Remove in numerical sequence **1...3**.
- Remove pressure plate **4** with „O“-Ring **5**.

Inspection / repair:

- Check guide plate **2** and pressure plate **4** as well as roller tappet **6** for wear or any other damage.
- Check surface condition of roller in connection with camshaft.

NOTE:

The roller tappet **6** must be replaced as a complete unit.

Pressure plate **4** available as spare part.

Assembly:

- Assemble in reverse sequence **6...3**.

NOTE:

Pay attention to position of pressure plate **4** in roller tappet.

Flat side towards injection pump !

- Place and push complete roller tappet **3** firmly in.

Guiding slot on TOP!

- Assemble in reverse sequence **2...1**.

Apply locking agent as specified !

- Check roller tappet for free movement in bore and guiding plate.

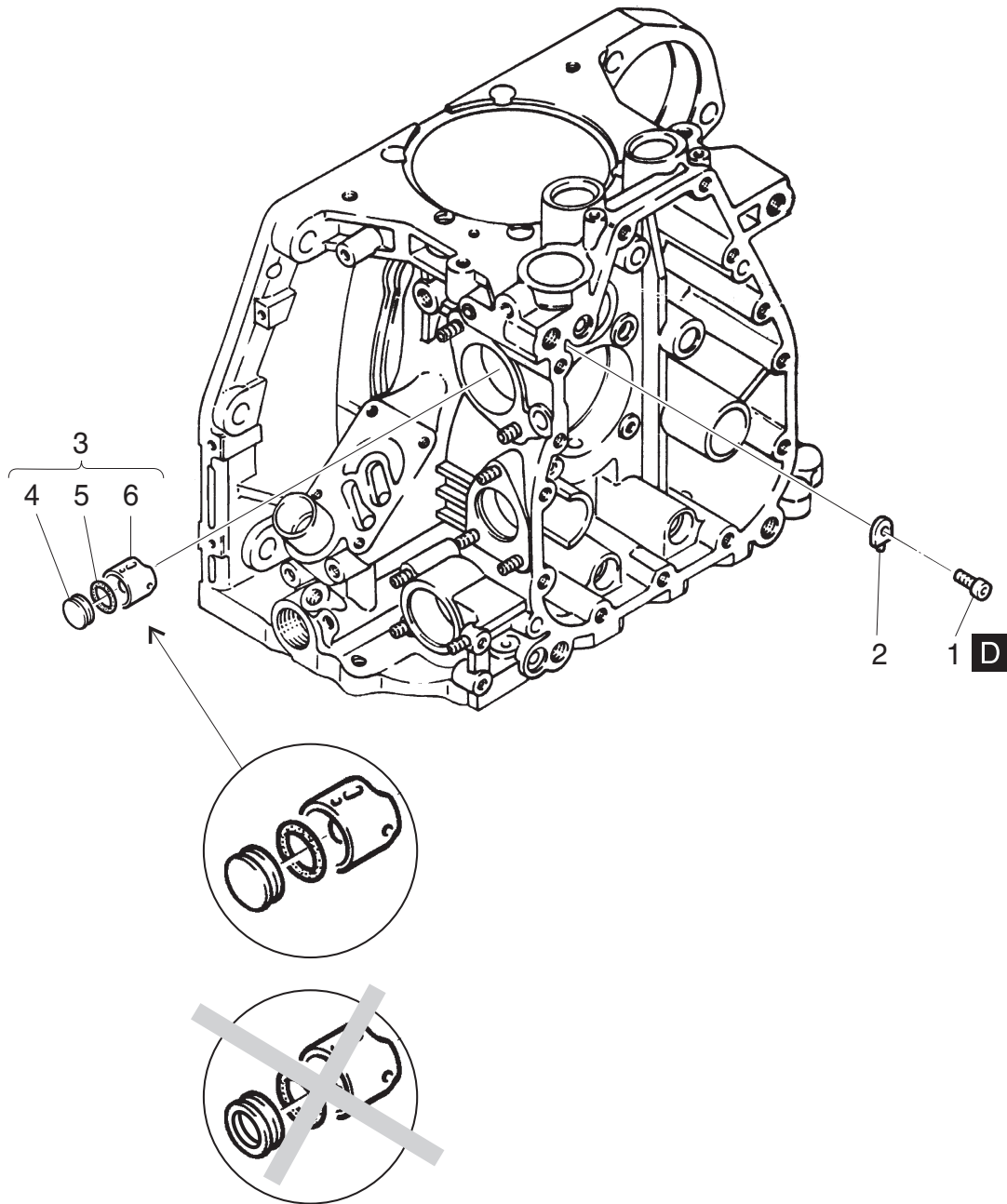

M 17.00 Flywheel



General:

1 D 30 - 31 - 35 - 40 - 41 - 50 only!

Fixation by Allen screws M 10.

1 D 60 - 80 - 81 - 90 only!

Fixation by Allen screws M 12.

Preparations:

Ref.: M-Disassembly cross reference scheme.

Dismantling:

- Remove in numerical sequence **1...3/4**.
For removal always use two studs (≈ 220 mm) to prevent the flywheel from falling.
Ensure not to lose centering bushing !

Inspection / repair:

- Check and clean cooling fan if necessary.

Assembly:

- Place centering bushing **4** into corresponding bore in crankshaft.
- Slide flywheel **3** over studs onto crankshaft.
Ensure centering bushing **4** remains in position !
- Assemble in reverse sequence **2...1**.
Torque to specification !

Flywheel markings:

OT = TDC / marks in degree

Version I - 1 D 80 only!

Counter mark in top position of adaptor housing.

The flywheel is marked with three lines from which the center one is the reference line.

Degrees before OT / TDC have to be calculated and measured from the reference line in direction of rotation. $1^\circ = 2,7$ mm

Version II

Counter mark on adaptor housing same as Version I.

OT / TDC-mark and degree numbers stamped into flywheel.

Version III

Adaptor housing with a control opening and cast-in counter mark.

Flywheel stamped with OT / TDC and degree marks at the corresponding sector.

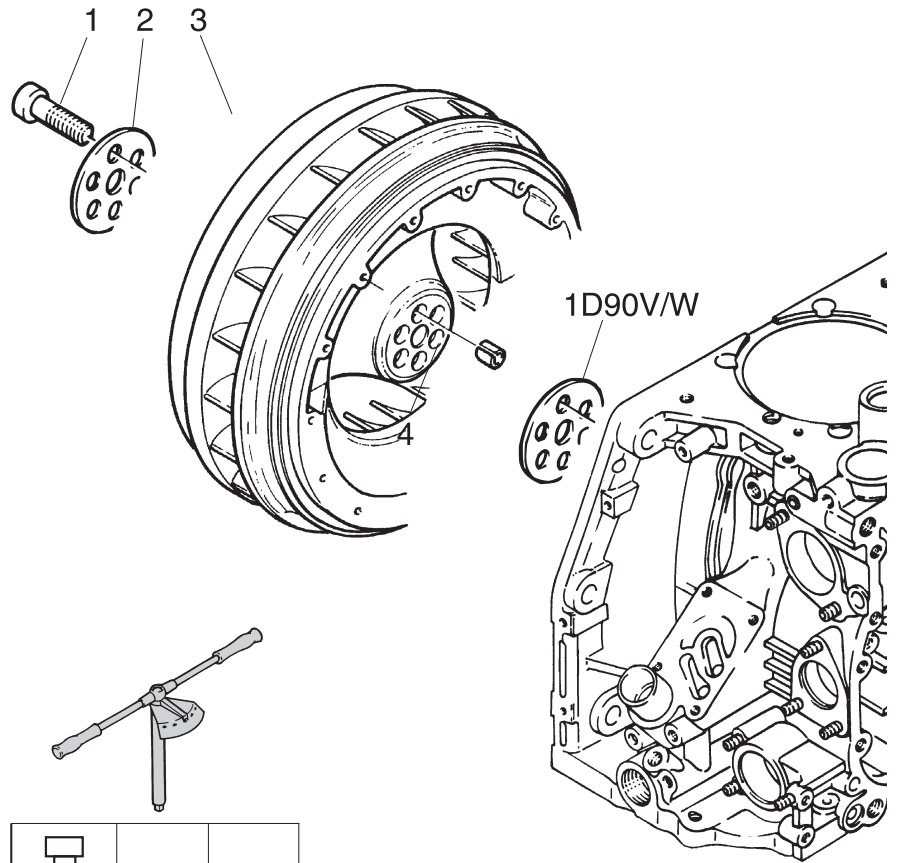

		Nm	lb ft
1D30-31-35-40-41-50	M10	68	50
1D60-80-81-90	M12	115	85

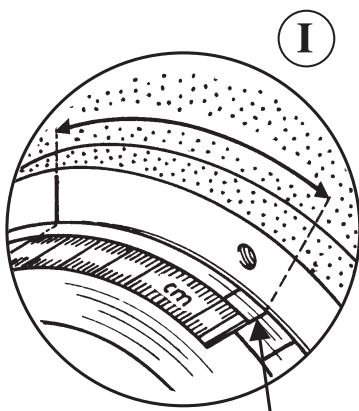

OT / TDC

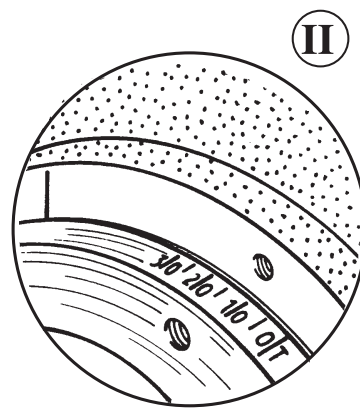

OT / TDC

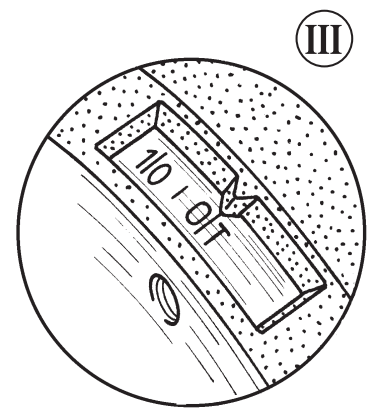

OT / TDC

M 26.00 Cowling / Air duct



Preparations:

Ref.: M-Disassembly cross reference scheme.

Dismantling:

- Due to the different variants in connection with electric start, handstart, anti- or clockwise direction of rotation etc. take care which parts like adaptor housing or any other parts in connection with the cowling system are fitted to avoid any mix up.

Inspection / repair:

- Check sealing strips as well as all other rubber parts for ageing etc.

Assembly:

- All corresponding parts according to the respective variants are identified and listed in the appropriate spare parts list and have to be fitted accordingly.

NOTE:

Never operate an engine with an incomplete cowling system.

A loss of cooling air may cause engine failure !

A 1 D ..

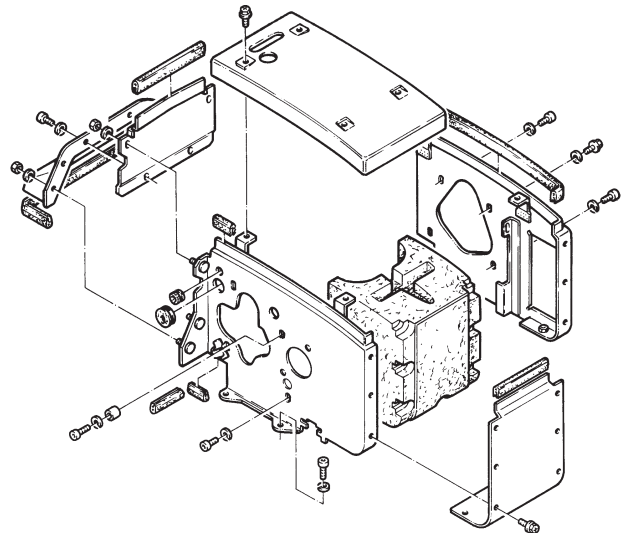

S / Z / T / U

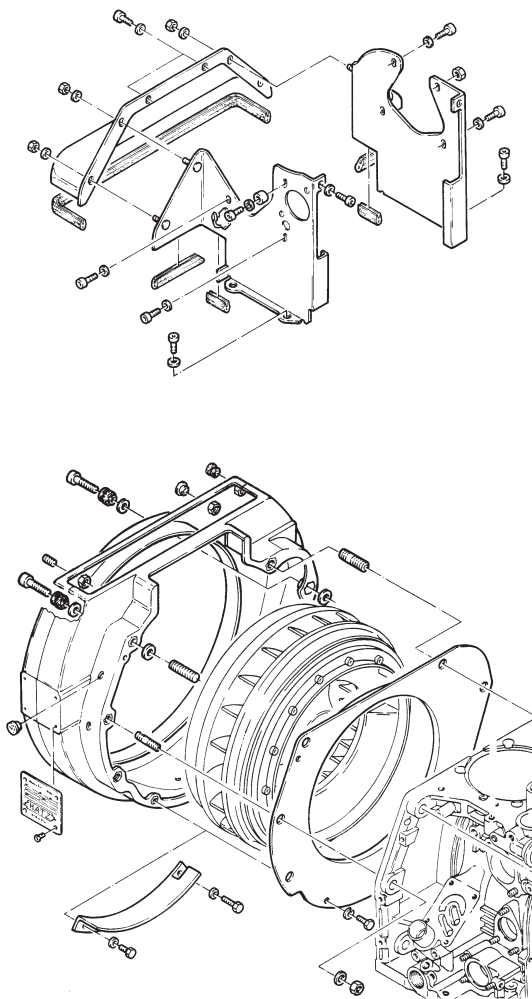

C

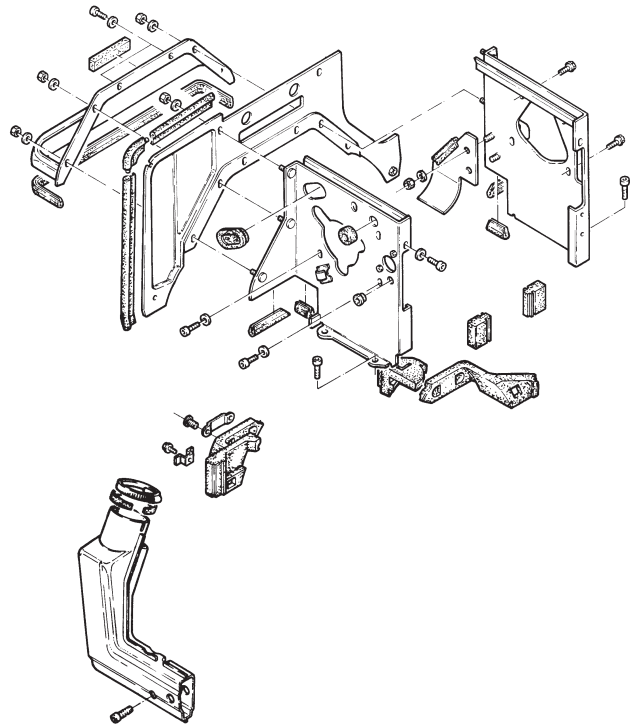

M 31.00 Breather system



General:

Crankcase breathing is done via a rubber type diaphragm into the air intake port. Whenever an engine is repaired, or indicates high lube oil consumption with blue exhaust smoke, the condition of the diaphragm should be checked.

Preparations:

Ref.: M-Disassembly cross reference scheme.

Version I

Diaphragm fitted into cyl.-head.

Dismantling:

- Carefully remove aluminium cover **1**.
- Remove diaphragm **2**.

Inspection / repair:

- Check diaphragm for fractures and/or material ageing.

Assembly:

- Place diaphragm **2** firmly into position.
- Place cover **1** with the convex side facing front into corresponding recess and lock cover by slightly beating down using a socket or similar tool.

Version II

(as from middle of 1992 onwards)

Diaphragm separate in plastic housing.

Dismantling:

- Remove in numerical sequence **3...5**.
 - Remove complete breather unit.
 - Remove cover **6** from housing **7** to remove diaphragm **8**.
- The breather hoses may remain.

Inspection / repair:

- Check all parts in question for fractures and/or material ageing.

Assembly:

- Complete breather unit **8...6**.
- Put breather unit onto corresponding connections.
- Assemble in reverse sequence **5...3**.

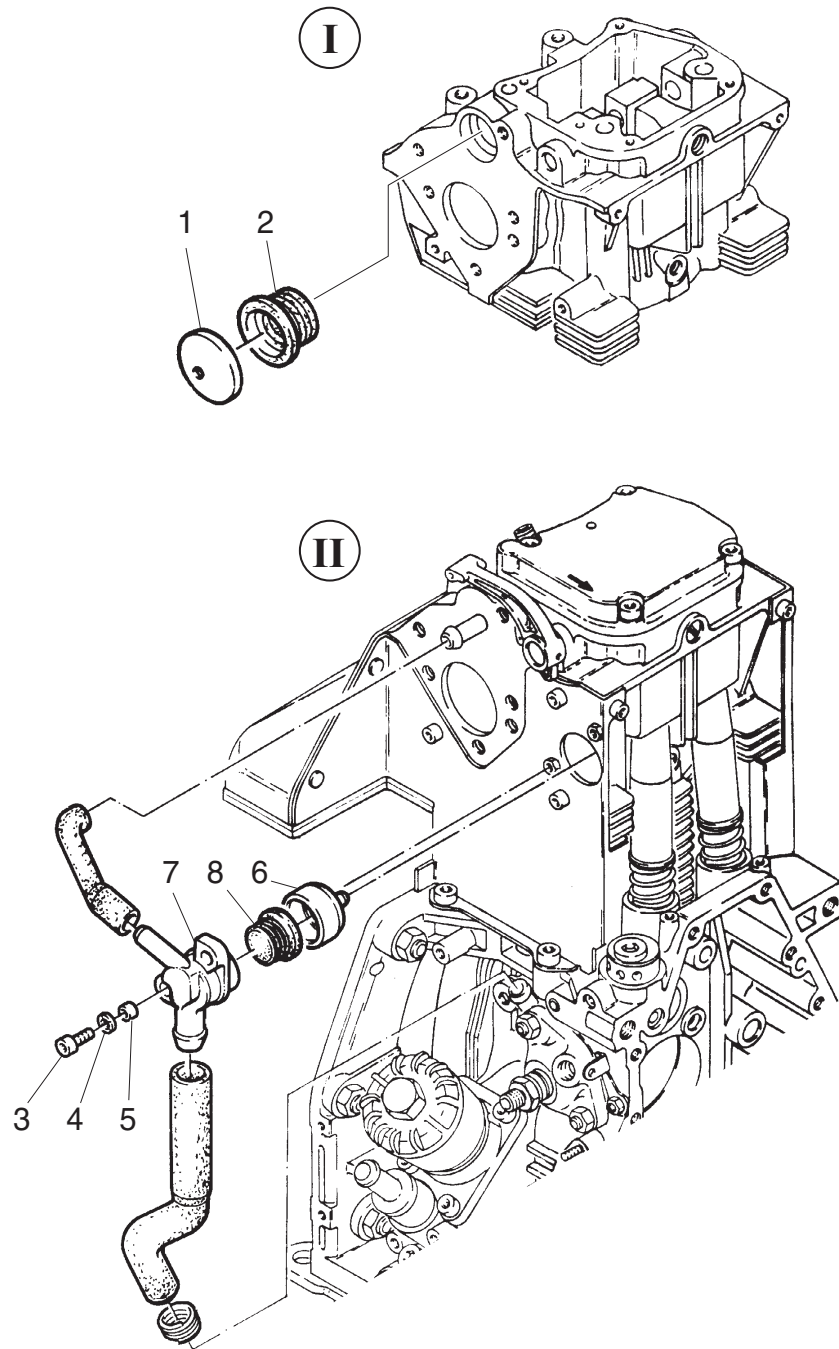

M 32.00 Speed control



General:

Speed control systems are different in construction as far as their use in connection with bowden or solenoid control is concerned.

Preparations:

Ref.: M-Disassembly cross reference scheme.

Version I

Early serial production.

Unsuitable in connection with bowden or solenoid control due to no frictionless movement of the speed control.

Version II

Early serial production.

Suitable in connection with bowden or solenoid control.

A conversion from Version I to Version II is possible by fitting the shaft assembly according to Version II.

Dismantling:

- Remove in numerical sequence **1...13**.
Governor lever **12** may remain as a unit, except for repair purposes.

Inspection / repair:

- Check all parts for wear or any other damage.

Assembly:

- Assemble in reverse sequence **13...1**.
Apply locking agent as specified !

Version III / IV as from middle of 1991

Suitable in connection with bowden or solenoid control.

Dismantling:

- Remove grub screw **14**.
- Remove in numerical sequence **7...11**.
- Remove complete unit **18/12**.
Governor lever **12** may remain as a unit except for repair purposes.
- Dismantle shaft assembly **18** in numerical sequence **19...25**.

Inspection / repair:

- Check all parts for wear or any other damage.

Assembly:

- Pre-assemble shaft assembly **18** in reverse sequence **25...19**.
- Assemble in reverse sequence **12/18...7, 17...15**.
Apply locking agent as specified !

Conversion:

Version I / II

Replaceable by Version III in case all parts in question become replaced.

Version III / IV

Identical in construction but different in the dimensions of the speed control stop **25** and fitted as follows:

Version III = crankcase in sand casting

Version IV = crankcase in diecasting

Version IV

Not interchangeable by Version III.

The possibility of the injection pump control sleeve sliding out of the governor lever guidance slot could occur i.e. the engine would not start.

The speed control stop **25** can be different too (with or without pin) but remains interchangeable within Version IV.

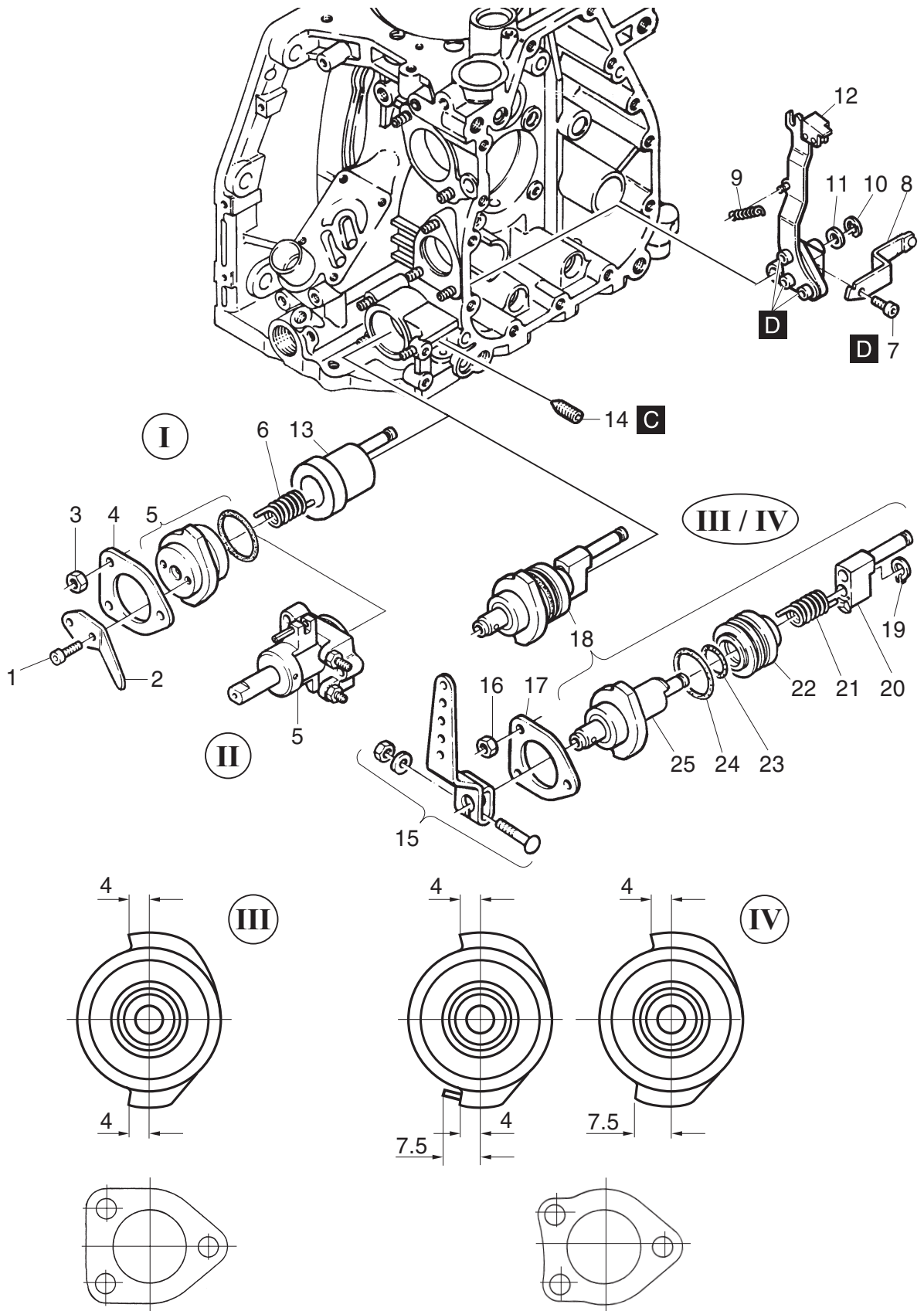

M 35.00 Capsule



Preparations:–

Dismantling:

- Remove all parts in question to get either access to the base engine as required or remove complete capsule in case a major overhaul has to be carried out.
- In case the external capsule parts are removed, the internal air ducting has to be removed too.

Inspection / repair:

- Check sealing strips as well as all other rubber parts for ageing etc.

Assembly:

- All corresponding parts are identified and listed in the appropriate spare parts list and have to be fitted accordingly.

NOTE:

Never operate an engine with an incomplete cowling system.

A loss of cooling air may cause engine failure !

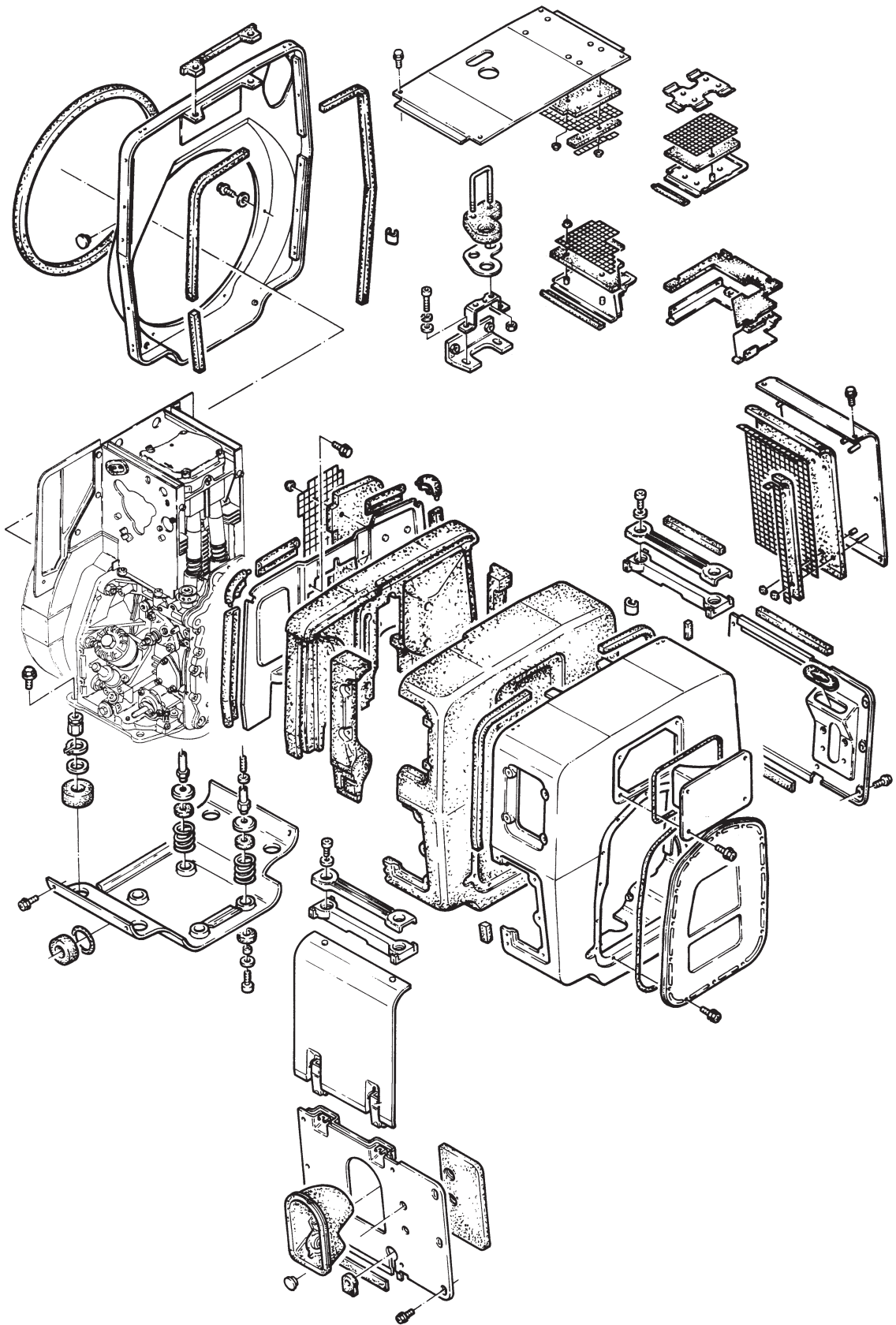

4. Tables

Injection equipment adjustment data

Injection pump timing and injection pressure

Models	refers to	engine speed	begin of delivery	injection pressure	
				[bar]	[psi]
(A) 1 D ...	Serial No.	[min ⁻¹]	° b TDC		
30S,Z,T,U,C 31S,Z,T,U,C 40S,Z,T,U,C 41S,Z,T,U,C	10 – 18 10 – 17 10 – 19 10 – 17	n > 3000 n ≤ 3000	23.0 + 1 20.0 + 1	200+8	2900+110
35S,Z	10 – 16	n ≤ 3000	16.0 + 1	200+8	2900+110
41S,Z,T,U,C	18 – 20	1500 ≤ n ≤ 1900 1900 < n ≤ 2400 2400 < n ≤ 3000 n > 3000 C: n > 3000	10.0 + 1 12.5 + 1 14.0 + 1 17.5 + 1 15.0 + 1	225+12	3250+160
41S,Z,C EPA II	21	2000 ≤ n ≤ 2250 2250 < n ≤ 2550 2550 < n ≤ 2900 2900 < n ≤ 3300	7.0 ± 0.5 8.5 ± 0.5 10.0 ± 0.5 12.5 ± 0.5	225+12	3250+160
41S,Z,C NON EPA	21	1500 ≤ n ≤ 2300 2300 < n ≤ 3000 3000 < n ≤ 3600	10.0 ± 0.5 12.0 ± 0.5 14.0 ± 0.5	225+12	3250+160
50S,Z,T,U	10 – 15	1500 ≤ n ≤ 1700 1700 < n ≤ 2300 2300 < n ≤ 3000 n > 3000	10.0 + 1 12.5 + 1 15.0 + 1 17.5 + 1	225+12	3250+160
50S,Z EPA II	16	2000 ≤ n ≤ 2300 2300 < n ≤ 2600 2600 < n ≤ 3300	6.0 ± 0.5 8.0 ± 0.5 10.0 ± 0.5	225+12	3250+160
50S,Z NON EPA	16	1500 ≤ n ≤ 2300 2300 < n ≤ 3000 3000 < n ≤ 3600	10.0 ± 0.5 12.0 ± 0.5 14.0 ± 0.5	225+12	3250+160
60S,Z,T,U 80S,Z,T,U	10 – 15 10 – 15	n ≤ 3000	19.0 + 1	250+8	3600+110
60C 80C	10 – 15 10 – 15	n ≤ 3000	21.0 + 1	250+8	3600+110
60S,Z,T,U,C 80S,Z,T,U	16 – 26 16 – 24	n ≤ 3000 n > 3000	21.5 + 1 24.5 + 1	250+8	3600+110
80C	16 – 24	n ≤ 3000 n > 3000	24.0 + 1 25.0 + 1	250+8	3600+110

Injection equipment adjustment data

Injection pump timing and injection pressure

Models	refers to	engine speed	begin of delivery	injection pressure	
				[bar]	[psi]
(A) 1 D ...	Serial No.	[min ⁻¹]	° b TDC		
81S,Z,T,U,C	10 – 19	n ≤ 3000	20.0 + 1	235+8	3400+110
90S,Z	10 – 14	n > 3000	23.0 + 1		
90 V,W	10				
81S,Z,C	20 – 23	1500 ≤ n ≤ 1800	8.0 + 1	270+12	3870+160
		1800 < n ≤ 2700	10.0 + 1		
		2700 < n ≤ 3000	13.0 + 1		
		3000 < n ≤ 3600	15.0 + 1		
81S,Z,C EPA II	24	1500 ≤ n < 2200	8.0 + 1	250+8	3600+110
		2200 ≤ n < 2300	9.0 + 1		
		2300 ≤ n < 2500	10.0 + 1		
		2500 ≤ n < 2600	11.0 + 1		
		2600 ≤ n < 2800	12.0 + 1		
		2800 ≤ n < 2900	13.0 + 1		
		2900 ≤ n ≤ 3000	14.0 + 1		
81S,Z NON EPA	24	1500 ≤ n ≤ 2000	13.0 ± 0.5	250+8	3600+110
		2000 < n ≤ 3000	15.0 ± 0.5		
		3000 < n ≤ 3600	16.0 ± 0.5		
81C NON EPA	24	1500 ≤ n ≤ 2000	13.0 ± 0.5	250+8	3600+110
		2000 < n ≤ 3000	15.0 ± 0.5		
90S,Z 90V,W	15 – 17 11 – 14	1500 ≤ n ≤ 1800	8.0 + 1	270+12	3870+160
		1800 < n ≤ 2700	10.0 + 1		
		2700 < n ≤ 3000	13.0 + 1		
90S,Z 90V,W EPA II	18 15	2000 ≤ n ≤ 2100	8.0 + 1	250+8	3600+110
		2100 < n < 2300	9.0 + 1		
		2300 ≤ n ≤ 2400	10.0 + 1		
		2400 < n < 2600	11.0 + 1		
		2600 ≤ n ≤ 2700	12.0 + 1		
		2700 < n < 2900	13.0 + 1		
		2900 ≤ n ≤ 3000	14.0 + 1		
90S,Z 90V,W NON EPA	18 15	1500 ≤ n ≤ 2000	13.0 ± 0.5	250+8	3600+110
		2000 < n ≤ 3000	15.0 ± 0.5		

Governor equipment

General

Type	min ⁻¹					Ident. - No.	mm			
		1500	1800	2300	2500		3000	3600	d	D
D 30 - 90	■	■	■	■	040 528 00	1.6	12.6	30.5	0-0.4
D 30 - 90	■	■	■	■	040 529 00	1.7	12.6	30.5	0-0.4
D 30 - 90	■	■	■	■	040 088 01	1.9	13.0	30.5	0-0.4
D 30 - 90	■	■	■	■	040 708 00	2.6	20.3	30.5	0-0.4
D 30-35-40	■	■	■	■	040 089 02	3.0	20.2	30.4	0-0.4
D 31-41-50 60-80-81-90	■	■	■	■	040 634 00	2.9	20.2	30.4	0-0.4
D 30-35-40	■	■	■	■	040 089 02	3.0	20.2	30.4	0-0.4
						040 088 01	1.9	13.0	30.5	
D 31-41-50 60-80-81-90	■	■	■	■	040 634 00	2.9	20.2	30.4	0-0.4
						040 088 01	1.9	13.0	30.5	

Compactors with low-idle speed stbilsation

Type	min ⁻¹					Ident. - No.				
		2500	3000	3600	d		D	I	S	
D 30 - 90	■	■	■	050 397 00	3.0	20.3	29.5	1.2	
D 30 - 90	■	■	■	050 397 00	3.0	20.3	29.5	0.7	
					052 014 00	1.6	12.6	29.5		

Engine generator sets: PV 78 - PV 171

Type	min ⁻¹					Ident. - No.				
		3000	3600	d	D		I	S		
D 30-35-40-60	■	■	040 634 00	2.9	20.2	30.4	0-0.4		
D 31-41-50 80-81-90	■	■	040 896 00	2.9	19.8	30.4	0-0.4		
D 30-35-40-60	■	■	040 634 00	2.9	20.2	30.4	0-0.4		
				040 088 01	1.9	13.0	30.5			
D 31-41-50 80-81-90	■	■	040 896 00	2.9	19.8	30.4	-0.5 ... -0.1		
				040 088 01	1.9	13.0	30.5			

..... = variabel ■ = konstant

Governor equipment

3000 min⁻¹

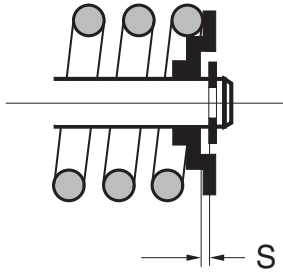
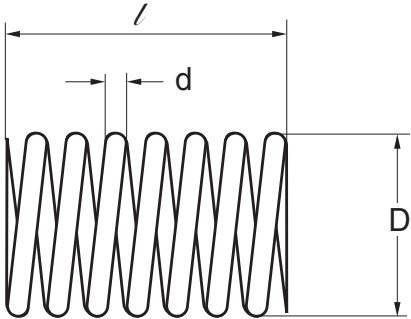

3600 min⁻¹

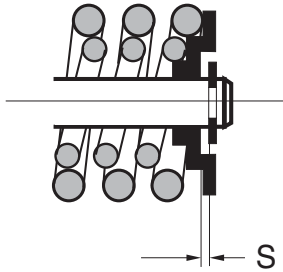
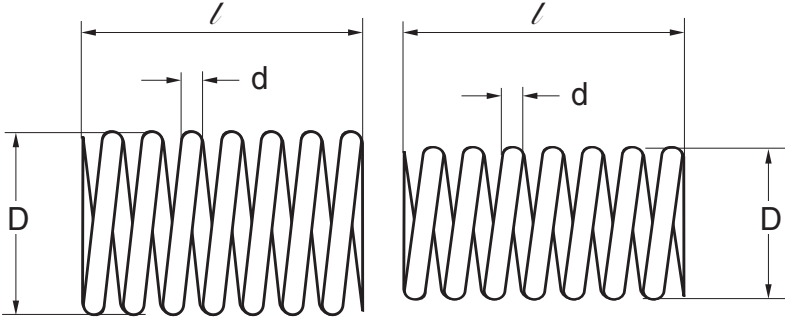

General adjustment and testing data

Bumping clearance

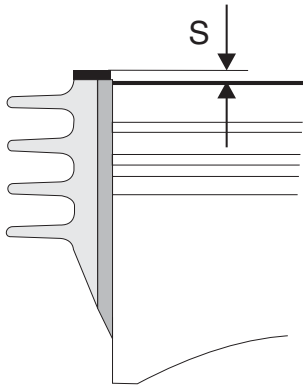

Type	S(mm)
1D30 - 80	0.65 - 0.75
1D41 / 50	0.60 - 0.65
1D81	0.75 - 0.80
1D90	0.80 - 0.85

Valve recession

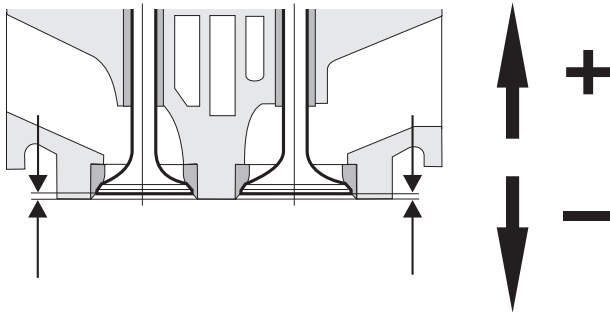

Type	nom. (mm)	max (mm)
1D30-35-40 60-80	0.90 -1.45	1.80
1D31/41	0.60±0.1	1.00
1D50	1.00±0.1	1.40
1D81/90	0±0.1	0.40
D41/50 EPA II	-0.60±0.1	-0.20

Tappet clearance (cold)

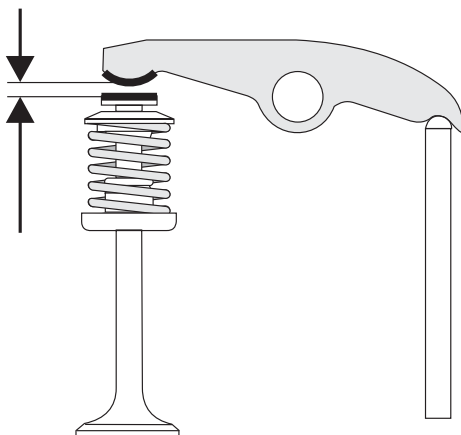

Type	In (mm)	Out (mm)
1D30 - 81	0.1+0.05	0.2+0.05
1D41	0.2+0.05	0.2+0.05
1D90	0.3+0.05	0.3+0.05

General adjustment and testing data

End-float of crankshaft

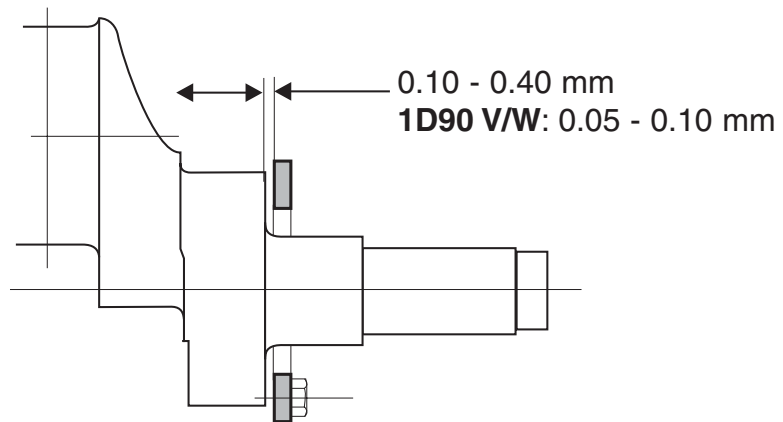

Alternator air gap

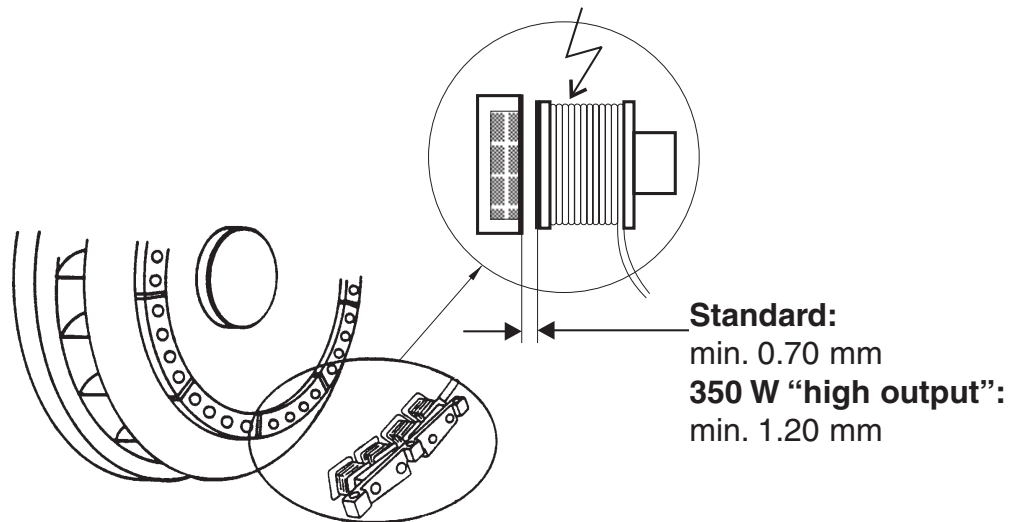

General adjustment and testing data

Lub. oil quant. (Vol.)

		tot.	diff.	tot.	diff.	tot.	diff.
1D30-31 A1D35 1D40-41	I	1,20	0,40	2,80	2,00	4,40	3,60
	USqts	1,27	0,42	2,96	2,11	4,65	3,80
1D60-80-81-90	I	1,90	0,90	3,20	2,20	4,50	3,50
	USqts	2,01	0,95	3,38	2,32	4,76	3,70
1D50	I	1,50	0,50				
	USqts	1,58	0,53				
1D90V/W	I	1,60	0,70				
	USqts	1,69	0,74				

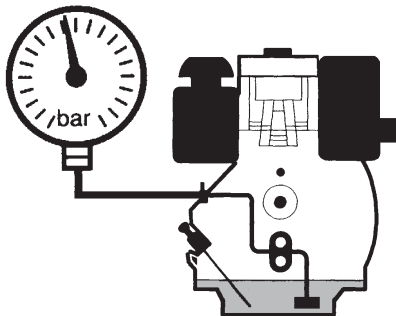

Lub. oil pressure

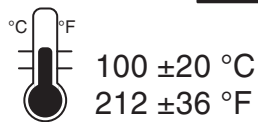

		min ⁻¹ ± 10%	850	1500	2300	3000
norm.	bar		0,8 – 1,9	1,5 – 2,5	2,5 – 3,5	3,5 – 4,5
	psi		12 – 28	22 – 36	36 – 51	51 – 65
min.	bar		0,6	1,2	1,8	2,5
	psi		9	17	26	36

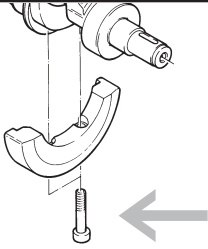
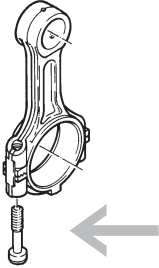
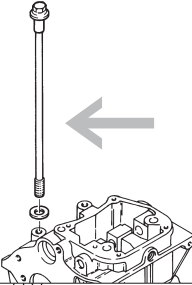
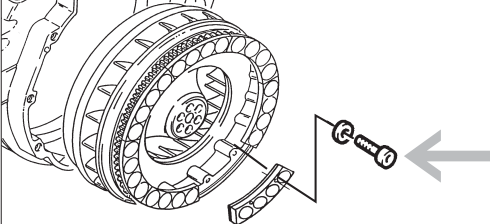
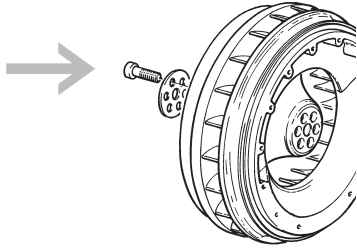

Torque wrench settings

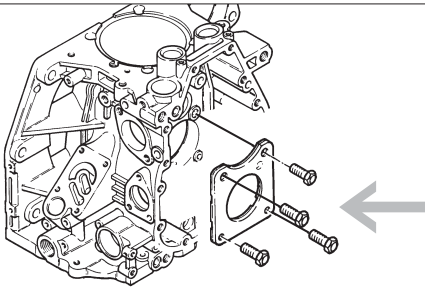
			1D 30-31-35-40-41-50		1D 60-80-81-90			
			Nm	lbf ft	Nm	lbf ft		
			40	30	75	55		
			40	30	85	63		
			50	37	80	59		
			2,8	2	2,8	2		
			68	50	115 190	85 140		
			M9	10.9	40	30	40	30
			M8	10.9	35	26	35	26
			M8	8.8	24	18	24	18
			M6	10.9	14	10	14	10

Torque wrench settings

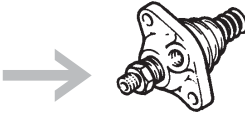
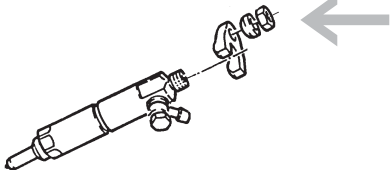
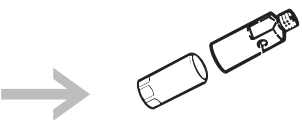
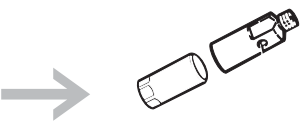
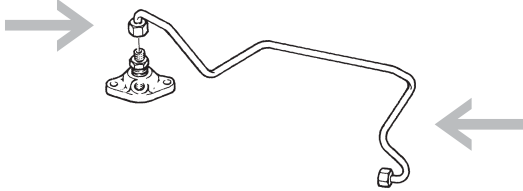
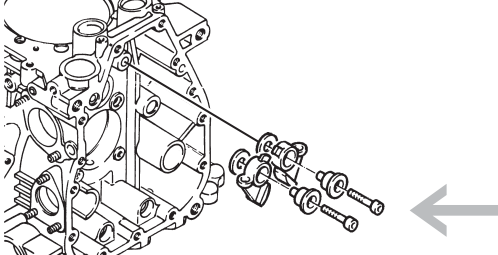
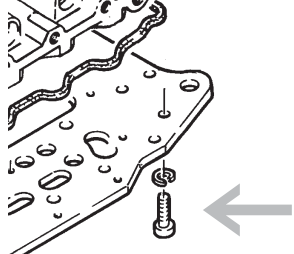
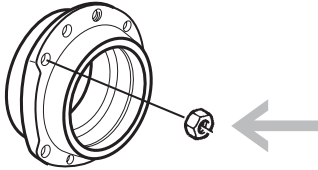
	1D 30 - 1D 90	
	Nm	lbf ft
	35	26
	23	17
 1D30-31-35-40-41-50-81-90	40 – 50	30 – 37
 1D60-80	50 – 70	37 – 52
	25	18
	11	8
	23	17
	30	22

Torque wrench settings

General [Nm]:

Nm ÷ 9.81(10) = kpm

Nm ÷ 1.3558 = Lb ft

Thread	Tensile quality			
	5.8	8.8	10.9	12.9
M 4	1.7	2.8	3.9	4.7
M 5	3.4	5.5	7.8	9.3
M 6	6.0	9.5	13	16
M 8	14	23	33	39
M 10	29	46	65	78
M 12	50	80	110	140
M 14	80	130	180	220
M 16	120	190	270	330
M 18	170	270	380	450
M 20	240	380	530	640
M 22	320	510	720	860

Code designations in circuit diagrams (DIN 40719)

Code	Designation of electrical component
A 1	Equipment box
A 2	Equipment panel
A 3	Automatic start-stop
A 4	Starter protection module
B 1	Temperature sensor
B 2	Speed pulse sensor
B 3	Oil pressure sensor
B 4	Horn
C1	Capacitor
E1	Heater for fuel filter
F1	Fuse
G1	Battery
G2	Generator (alternator)
G3	Flywheel generator
H 1	Indicator lamp, generator telltale
H 2	Indicator lamp, oil pressure
H 3	Indicator lamp, engine temperature
H 4	Indicator lamp, air cleaner (maintenance switch)
H 5	Indicator lamp, broken belt
H 6	Indicator lamp, preheat monitor
H 7	Indicator lamp, fan monitor
H 8	Remote display: engine on
K 1	Control relay 1 for start / start repeat interlock
K 2	Control relay 2 for preheat
K 3	Control relay 3 für speed control
K 4	Engine protection relay
K 5	Delay relay
K 6	Start interlock relay
K 7	Timer relay (impulse relay)
K 8	Power relay
M1	Starter motor
MG	Starter-generator
N 1	Regulator for starter-generator
N 2	Regulator for flywheel generator
N 3	Regulator for alternator (unless integrated)
N 4	Pulse sensor (additional for syncro-regulator)

Code designations in circuit diagrams (DIN 40719)

Code	Designation of electrical component
P 1	Operating hours counter
P 2	Revolution counter
P 3	Pressure display
R 1	Preheat glowplug
R 2	Heating flange
R 3	Line resistor for preheat system
R 4	Resistor
R 5	Line resistor with thermal time switch
S 1	Preheat starter switch (5 positions)
S 2	Master switch
S 3	Preheat starter switch (3 positions)
S 4	Start-stop switch
S 5	Speed control switch
S 6	Engine temperature switch
S 7	Oil pressure switch
S 8	Pressure switch for air cleaner
S 9	Fan monitoring switch
S 10	Preheat temperature switch
S 11	Remote start switch
S 12	Remote stop switch
T1	Engine speed measurement transmitter
V 1	Decoupling diode
V 2	Freewheeling diode
V 3	Zener diode
V 4	Suppressor diode
W 1	Earth (ground), negative return line
W 2	Screened line at generator
X 1	Terminal strip on equipment box
X 2	Flat-plug distributor
X 3	Plug at emergency stop switch
X 4	Socket on emergency stop switch
X 5	Terminal block on control box / terminal box
Y 1	Speed control actuating solenoid
Y 2	Engine shutdown actuating solenoid
Y 3	Servo solenoid (= valve solenoid) for engine shutdown
Y 4	Fuel shutoff valve
Y 5	High-pressure shutdown valve
Z 1	Suppressor choke
Z 2	Suppressor capacitor

HATZ wiring designations

Terminal	Designation
0	Earth (ground)
1	Generator B+
2	With alternator: D+ With flywheel generator: Terminal L at regulator
3	Starter terminal 50
4	Oil pressure switch
5	Temperature switch on cylinder head
6	Preheat glowplug I
7	Engine shutdown solenoid
8	Preheat glowplug II
9	Start-stop input
10	Positive terminal for DC motor, precision speed control
11	Negative terminal for DC motor, precision speed control
12	Oil pressure sensor
13	* * * reserved for special applications * * *
14	Speed control solenoid - holding-on winding
15	* * * reserved for special applications * * *
16	Actuating solenoid for decompressor
17	Maintenance switch for air cleaner
18	Engine shutdown solenoid (energising winding)
19	Temperature sensor at cylinder head
20	Oil temperature switch
21	Fan monitoring switch
22	Terminal W for engine-speed measurement
23	Starter 30 (with ammeter connection)
24	Terminal C with regulator on flywheel generator
25	Oil temperature sensor
26	Terminal 50f at starter protection module
27	* * * reserved * * *
28	Speed control solenoid (energising winding)
29	* * * reserved * * *

Code marking with electrical wires

Connector assignement Engine

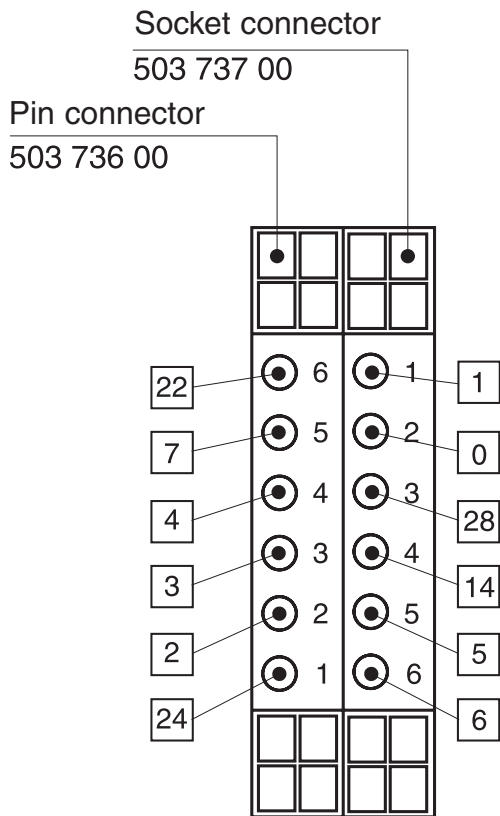

Connector assignement Wiring harness

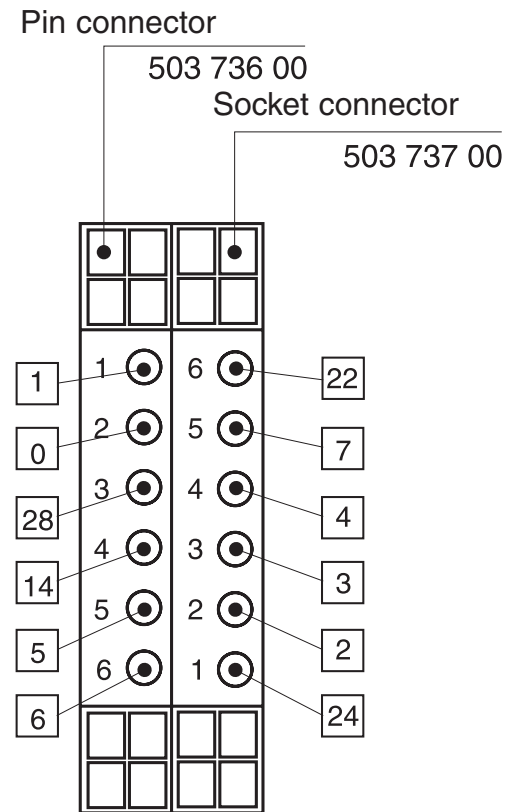

- 0 Battery - (earth)
- 1 Battery +
- 2 Terminal L at regulator with flywheel generator
- 3 Starter terminal 50
- 4 Oil pressure switch
- 5 Temperature switch on cylinder head
- 6 Preheat glowplug
- 7 Engine shutdown solenoid
- 14 Speed control solenoid - holding-on winding
- 22 Terminal W for engine-speed measurement
- 24 Terminal C with regulator on flywheel generator
- 28 Speed control solenoid (energising winding)

For removal of pin and socket connectors use tool **-1-**.

Circuit diagram - electrical system with display

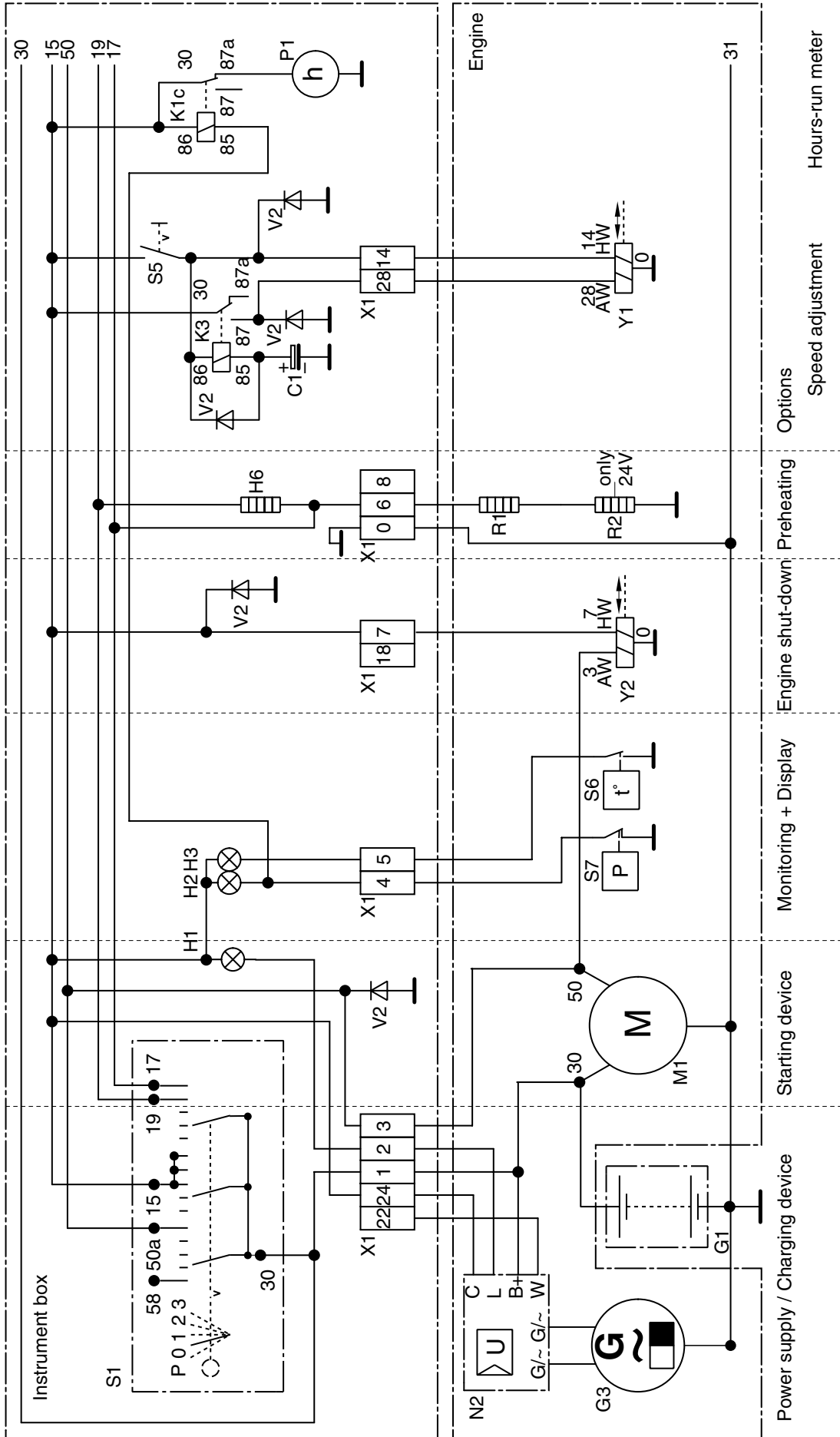

Circuit diagram - electrical system with automatic start / stop

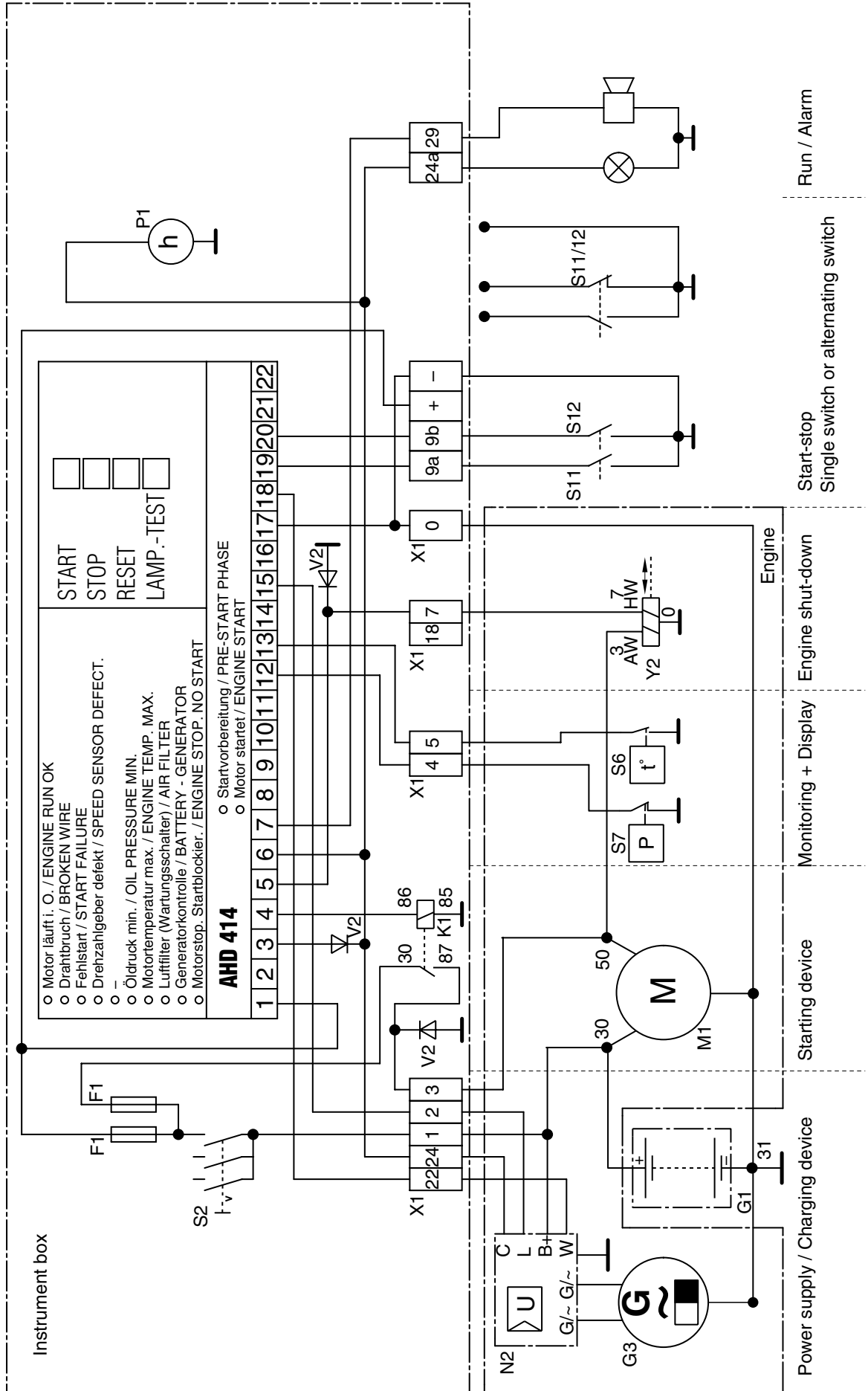

Circuit diagram - Instrument box with display

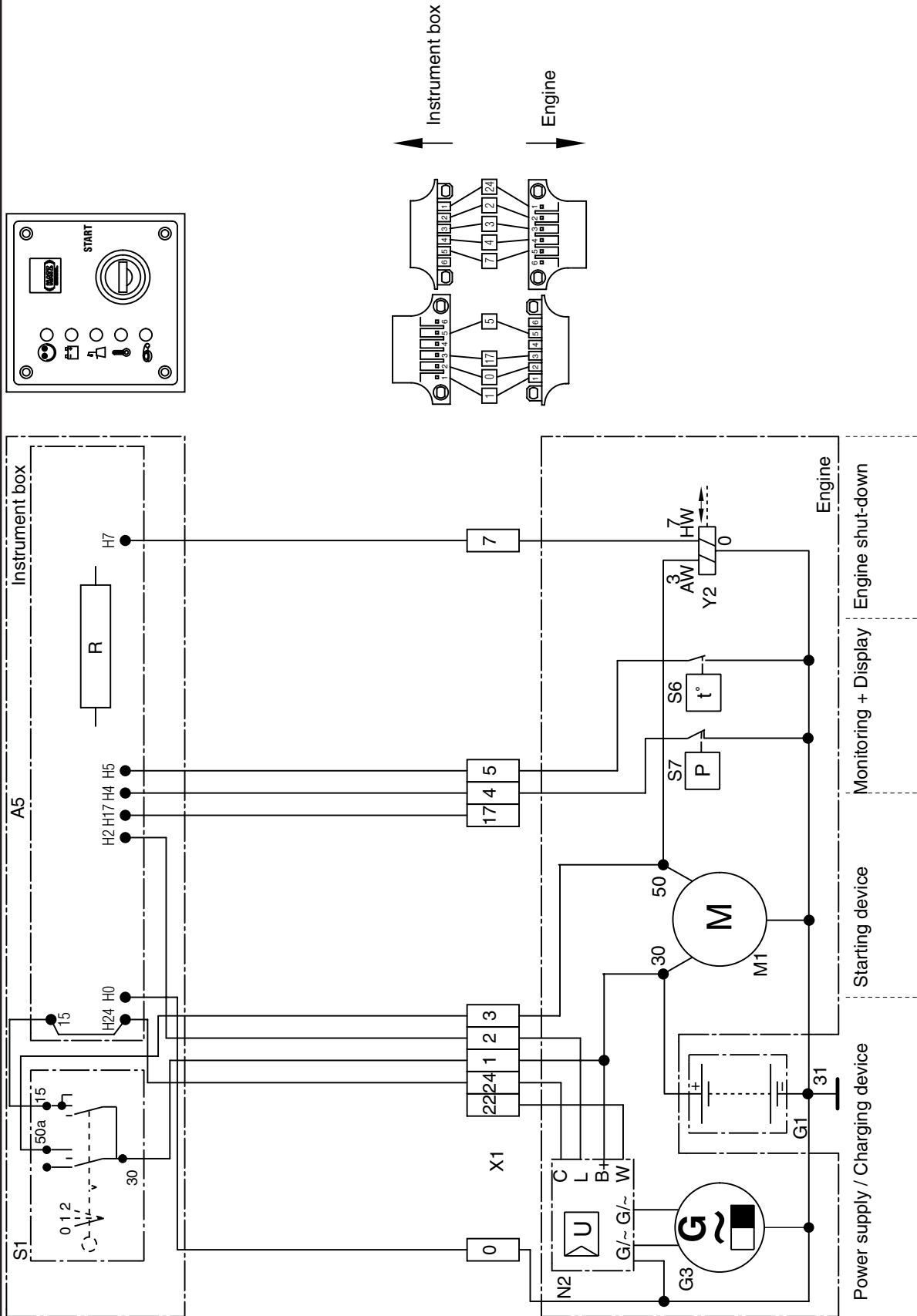

Circuit diagram - Instrument box with autom. pre-heat and shut down system

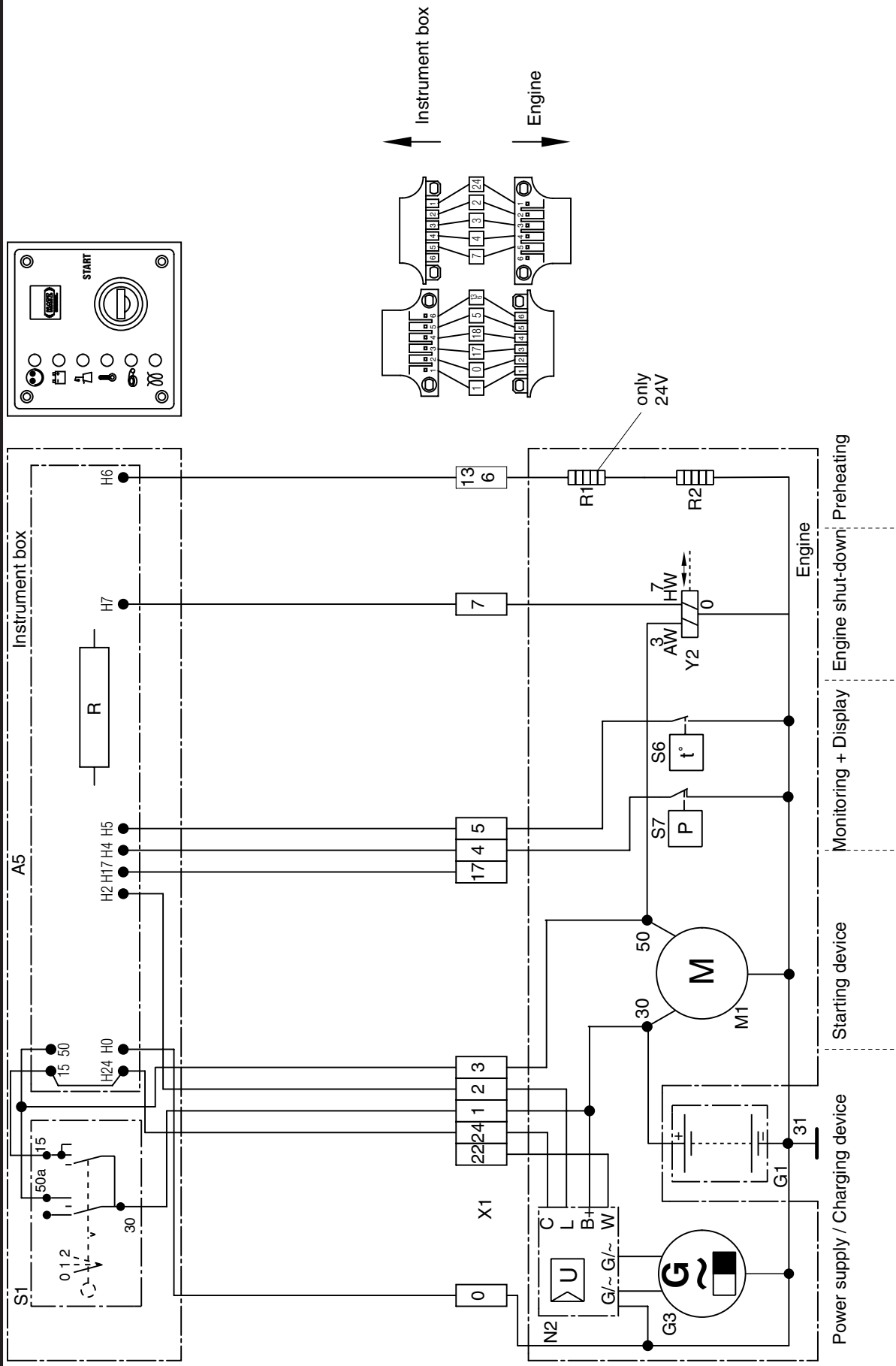

Circuit diagram - Instrument box with display and power box

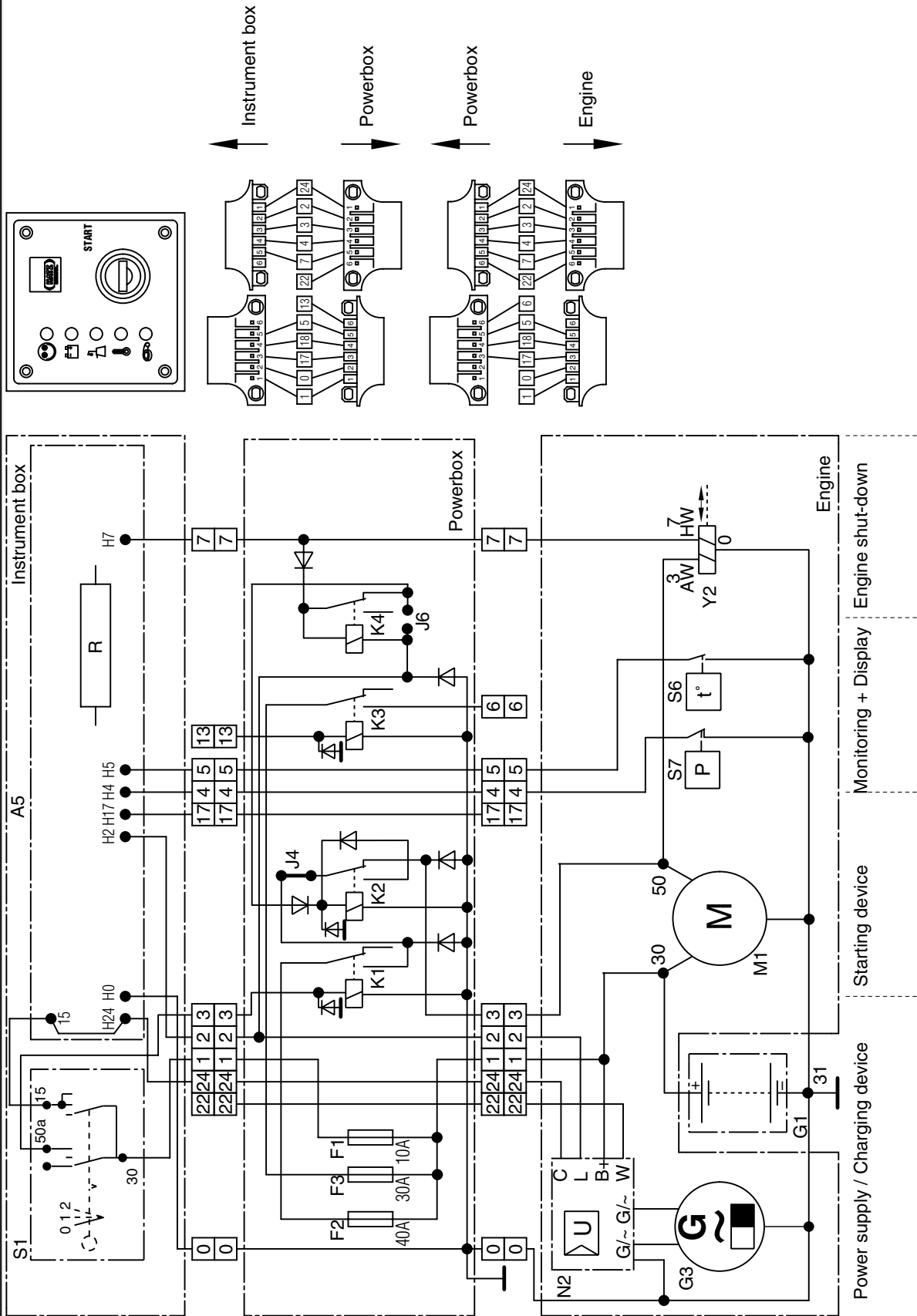

Circuit diagram - Instrument box with autom. pre-heat / shut down system and power box

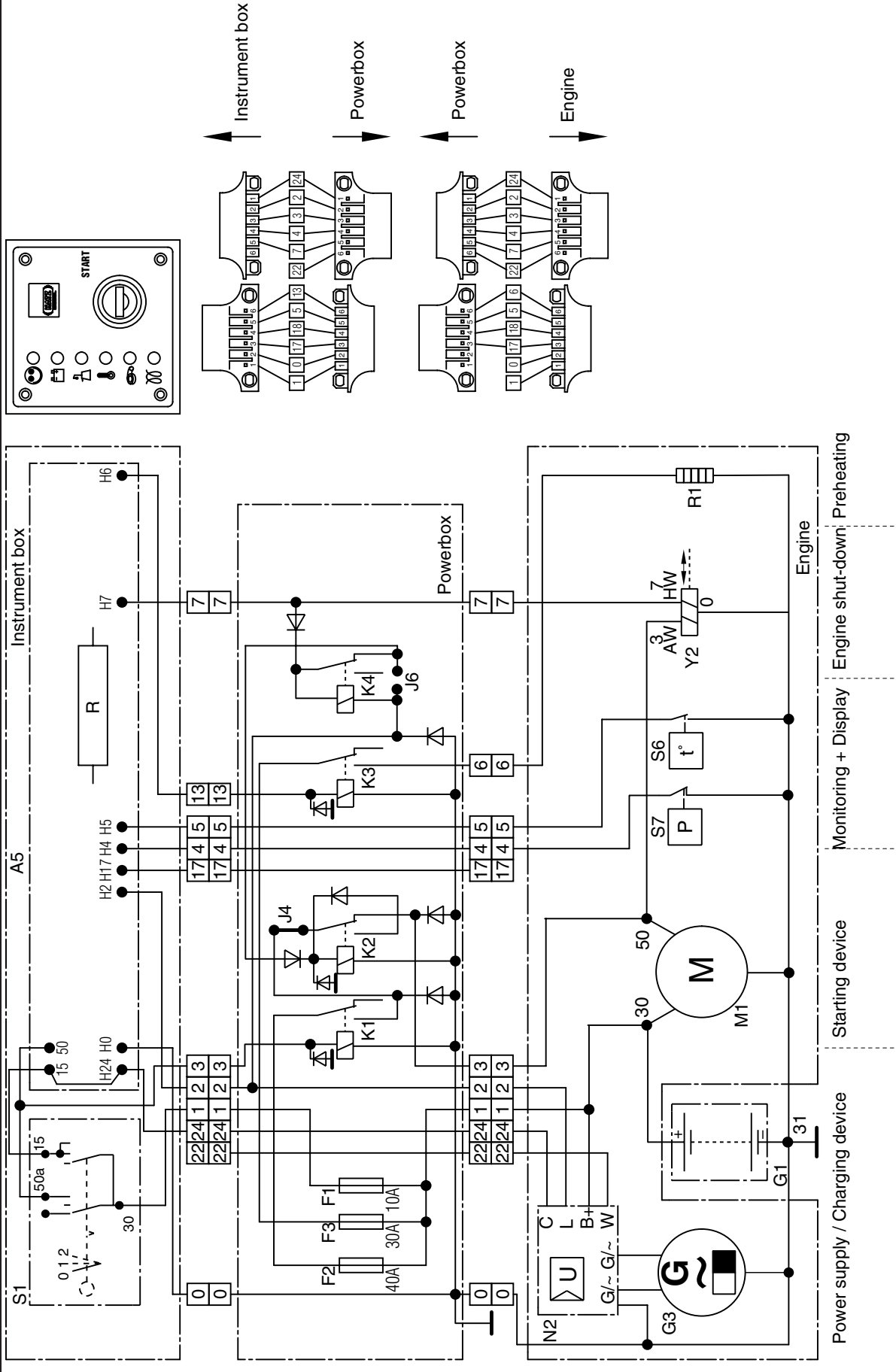

Wiring diagramm for alternator testing

Test of charging current:

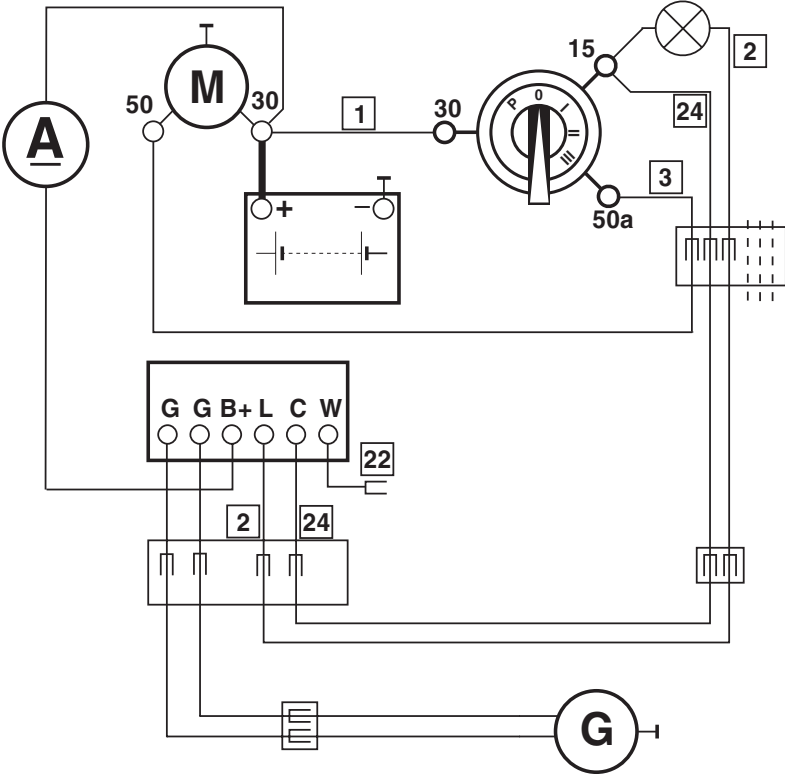

Test of no-load-voltage:

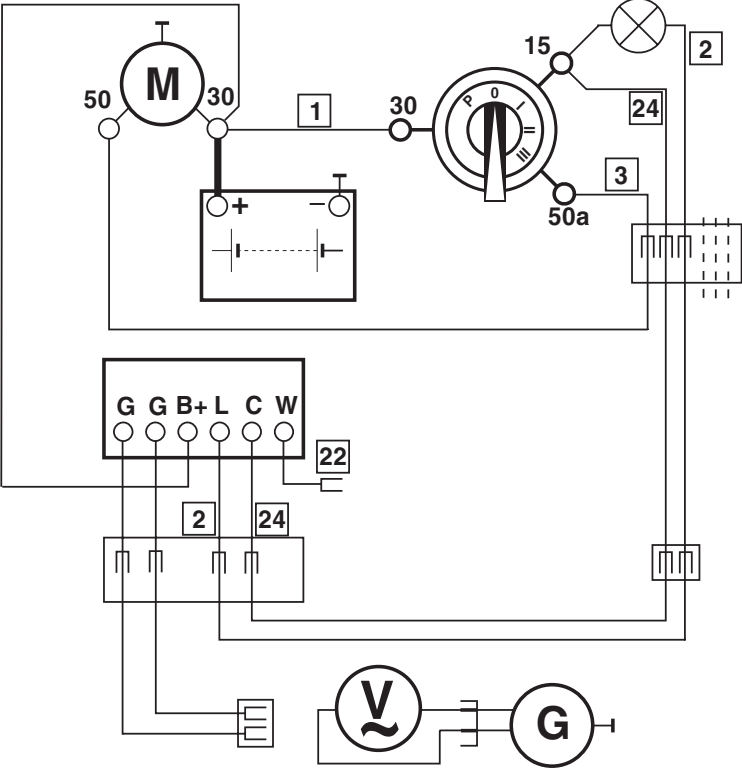

Alternator data 12 V

1 D 30 - 35 - 40

open coils (3 x 2)

Charging current:

Battery voltage 13.2 V, normal operation temperature

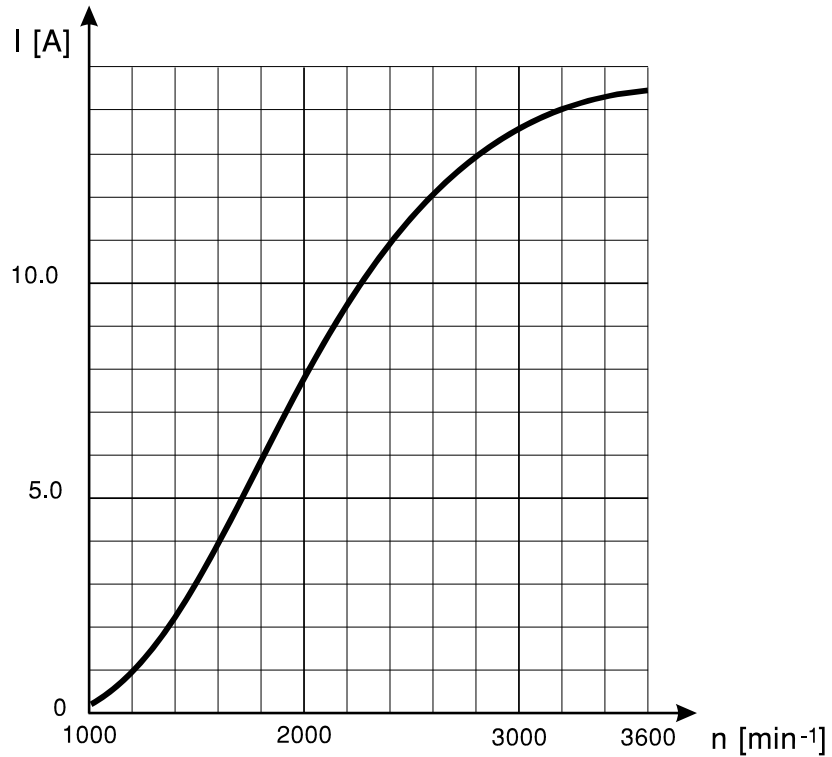

No-load voltage:

measured between the yellow leads of the coils (voltage regulator disconnected)

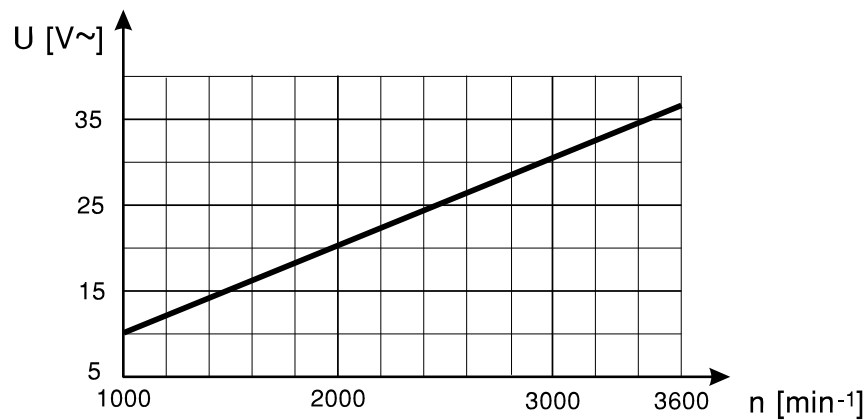

Alternator data 12 V

1 D 30 - 31 - 35 - 40 - 41 - 50

encapsulated coils

Charging current:

Battery voltage 13.2 V, normal operation temperature

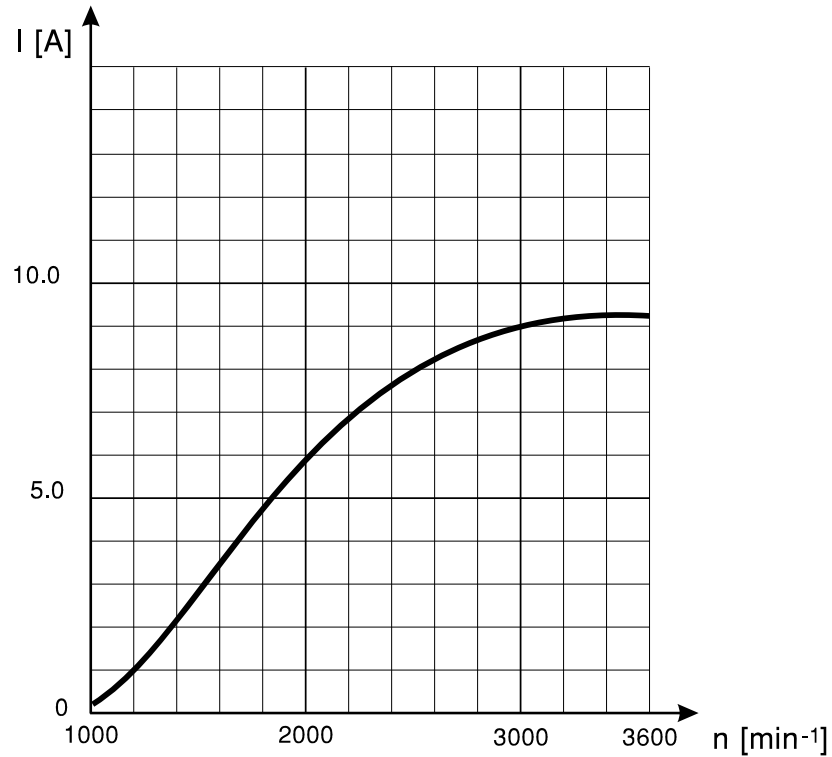

No-load voltage:

measured between the yellow leads of the coils (voltage regulator disconnected)

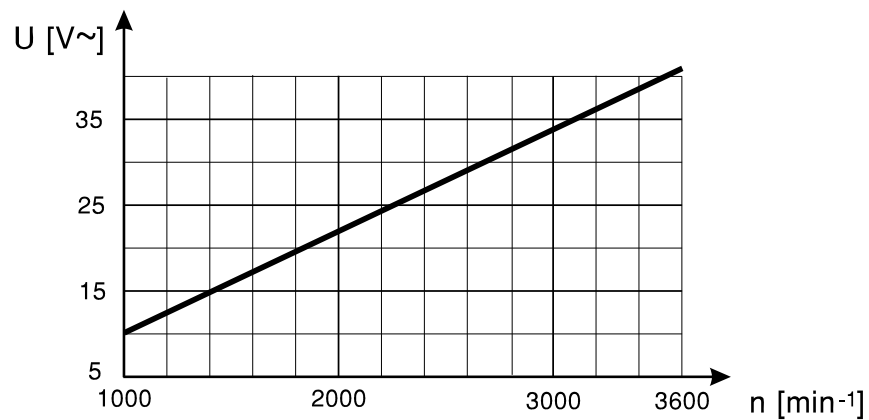

Alternator data 12 V

1 D 60 - 80 - 81 - 90

open as well as encapsulated coils

Charging current:

Battery voltage 13.2 V, normal operation temperature

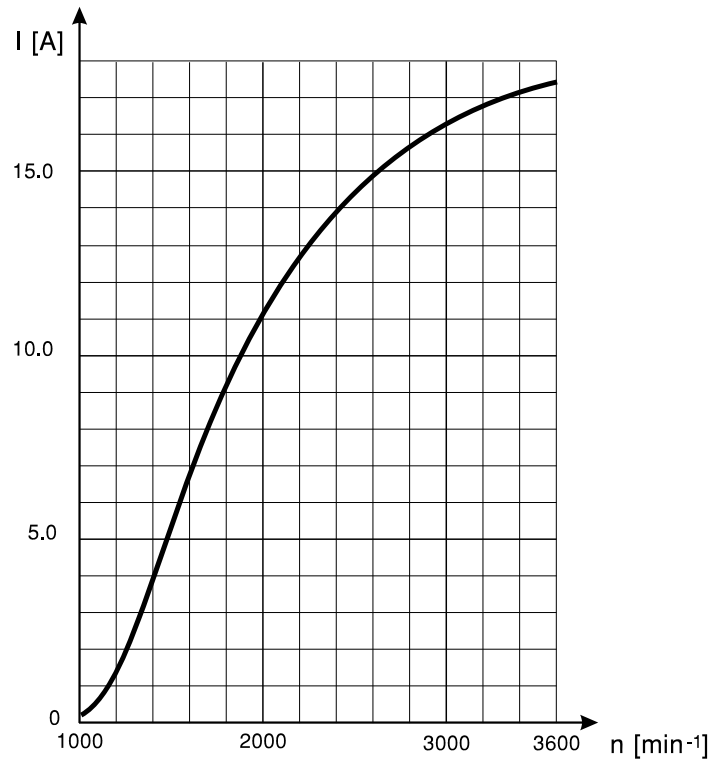

No-load voltage:

measured between the yellow leads of the coils (voltage regulator disconnected)

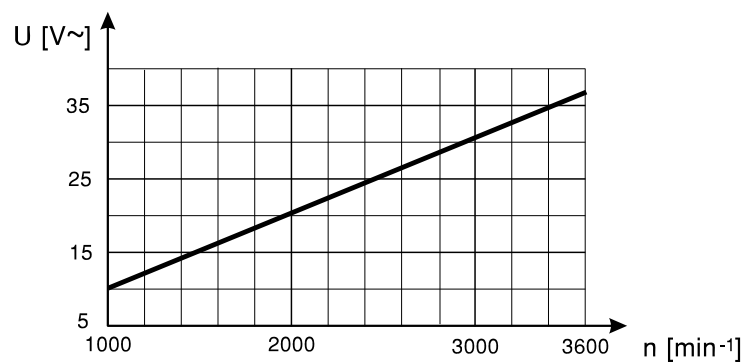

Alternator data 24 V

1 D 30 - 35 - 40

open coils (3 x 2)

Charging current:

Battery voltage 26.4 V, normal operation temperature

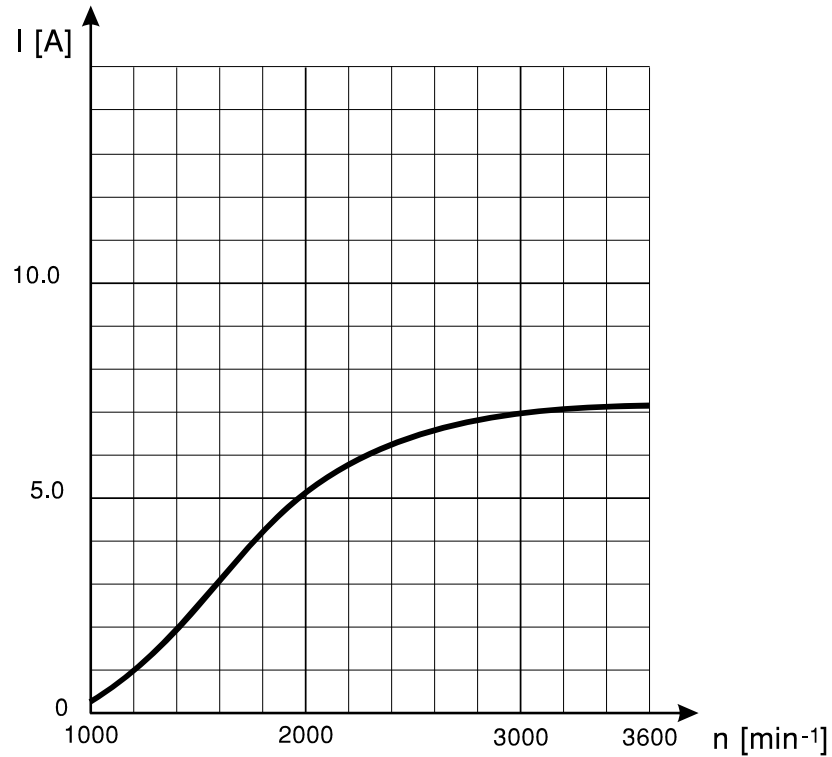

No-load voltage:

measured between the yellow leads of the coils (voltage regulator disconnected)

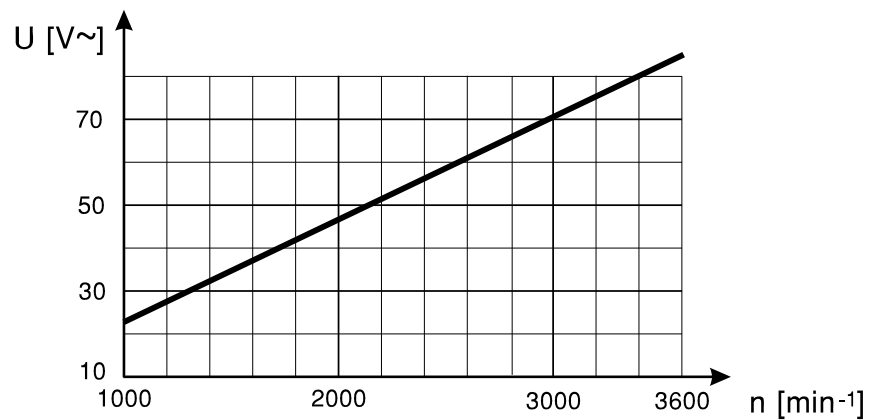

Alternator data 24 V

1 D 30 - 31 - 35 - 40 - 41 - 50

encapsulated coils

Charging current:

Battery voltage 26.4 V, normal operation temperature

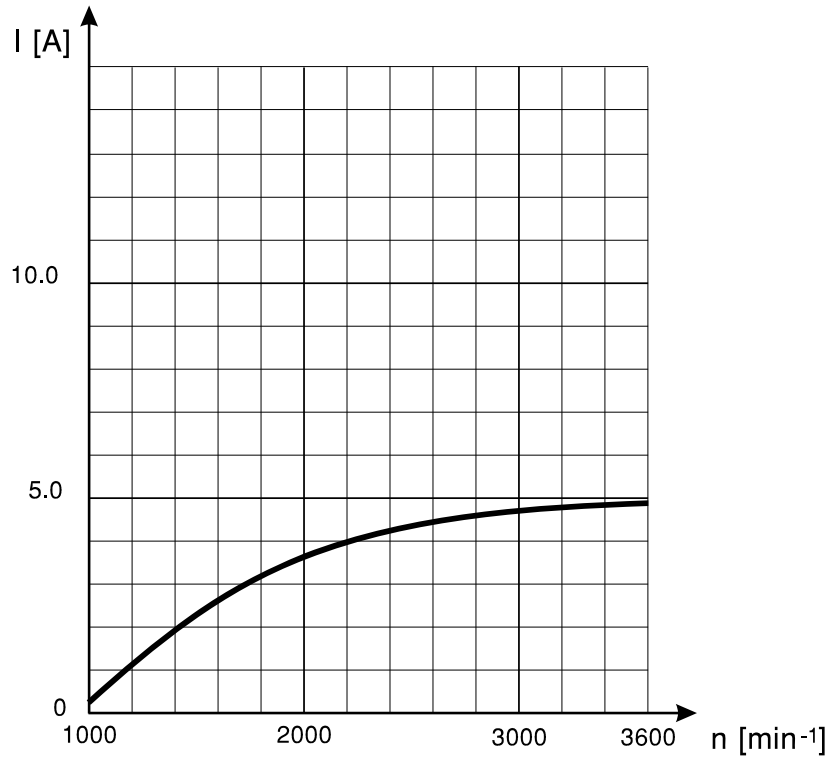

No-load voltage:

measured between the yellow leads of the coils (voltage regulator disconnected)

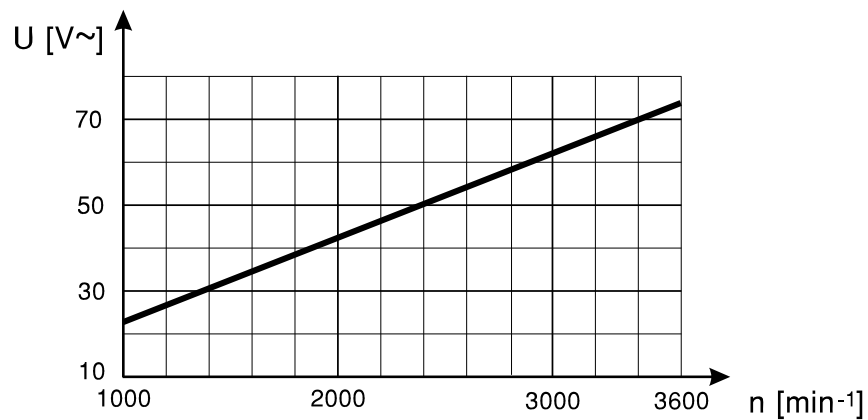

Alternator data 24 V

1 D 60 - 80 - 81 - 90

open as well as encapsulated coils

Charging current:

Battery voltage 26.4 V, normal operation temperature

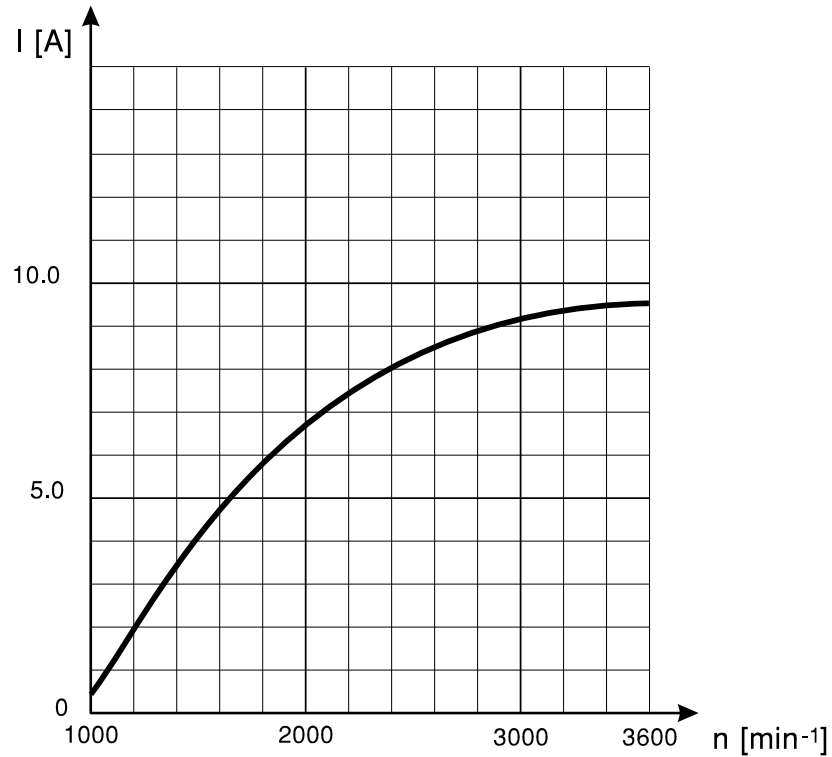

No-load voltage:

measured between the yellow leads of the coils (voltage regulator disconnected)

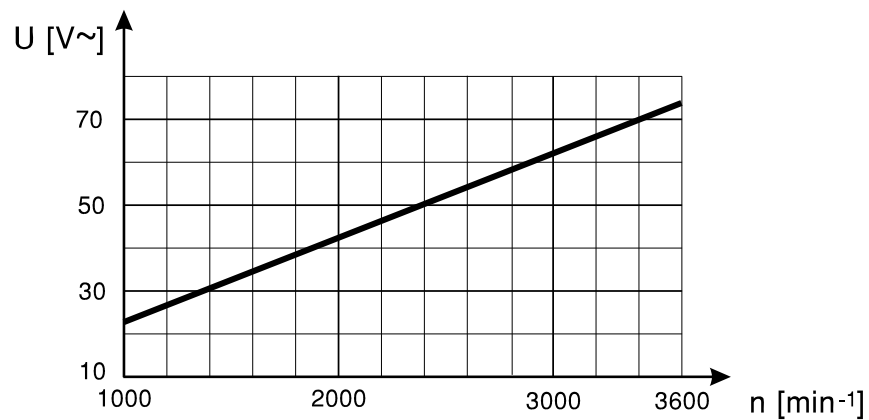

Troubleshooting chart - electrical system

Troubleshooting at the battery

Malfunction	Indication	Possible cause	Remedial action
Battery is not being charged sufficiently or at all, or is being discharged too rapidly.	Even shortly after charging, the terminal voltage drops rapidly to 7 V on systems with 12 V nominal voltage.	Poor connections, open circuit or contact resistance in charging circuit, short-circuit in line.	Eliminate open circuit, clean posts and clips, tighten loose terminals.
		Battery defective (internal short circuits).	Renew the battery.
		Battery capacity has dropped severely due to severe discharge for a lengthy period (grey-white coating on plates ("sulphatising")).	Recharge battery at low current (app. 1/40 of nominal capacity in Amps) for about 50 hours. (Only possible if sulphatising not yet too far advanced.) Otherwise: renew battery.
		Charging rate too low (especially in winter).	Recharge the battery.
		Battery capacity too large.	Install a smaller battery.
		Defective voltage regulator (e.g. overheated/overloaded).	Renew the voltage regulator.
Battery is overcharged.	Terminal voltage permanently above 16.5 V at 12 V nominal voltage, acid density above 1.285 kg/l, battery acid boils.	Charge voltage too high.	Check voltage regulator, renew if necessary.
		Battery capacity is too low.	Install a larger-capacity battery. As a temporary measure, discharge the battery at intervals, e.g. by switching on consumers without running the engine.
		Defective voltage regulator.	Check voltage regulator, renew if defective.
	Acid emerging at cell plugs.	Acid level too high.	Draw off excess acid with hygrometer.

Troubleshooting chart - electrical system

Troubleshooting at the battery

Malfunction	Indication	Possible cause	Remedial action
Post terminals corroded.	Insufficient current transfer, "bloom" (white salt deposit).	Sulphuric acid attacks metals (except lead).	Wash the posts and terminals down with hot soda solution (but this must not enter the battery!), rinse with cold water and apply acid-resistant grease.
Acid level too low.	Acid level less than 10 mm (0.4 in) above top of cell plates.	Overloading, natural water loss caused by evaporation (esp. in summer).	Add distilled or demineralised water.
Battery life too low.		Battery was discharged too far or too frequently.	Check ratings of battery and generator, if necessary use a special "Z" or "HD" battery.
		Battery tends to over-heat.	Choose a better installed position.
		Excessive loads imposed by vibration.	Choose a better installed position or use an "Rf" (vibration-proof) battery.
		Batterie is "sulphatising".	Recharge battery at low current (app. 1/40 of nom. capacity in Amps) for app. 50 hours. Otherwise: renew battery
		Impurities in battery acid.	Renew the battery.

Troubleshooting chart - electrical system

Troubleshooting at the battery

Malfunction	Indication	Possible cause	Remedial action
Battery output is too low.	Voltage drops severely when a load is applied.	Battery is flat (discharged).	Recharge battery.
		Charging voltage is too low: voltage regulator is defective.	Renew the voltage regulator.
		Connecting terminals loose or oxidised.	Clean connecting terminals, apply acid-resistant grease, tighten terminal clips.
		Battery capacity too low (too many consumers).	Install a larger battery.
		Battery discharged because of impurities in the acid..	Renew the battery.
		Battery is "sulphatising" (white deposit on cell plates).	Recharge the battery at low current for app. 50 hours, or renew the battery.
		Battery is exhausted; active material has failed.	Renew the battery.
		Acid level too low.	Add distilled water.
Long-term charging rate is insufficient.	Terminal voltage drops to 7 V nominal voltage (12 V circuit) even shortly after recharging.	Fault at generator, voltage regulator or cable connections.	Repair or renew the generator and voltage regulator, make sure that all line connections are tight.
		Too many consumers connected to the circuit, or generator is too small.	Choose more suitable battery - generator ratings.

Troubleshooting chart - electrical system

Troubleshooting at the starting equipment

Malfunction	Indication	Possible cause	Remedial action
Starter does not rotate when preheat - starting switch is operated.	Generator indicator lamp is not on.	Poor connection (loose or oxidised), break in cable or short to earth (ground).	Check battery cables and connections, clean battery posts and terminals, make sure that connections are tight.
		Battery flat or defective.	Recharge or renew the battery.
	Indicator lamp darkens slowly when preheat-starter switch is operated.	Battery is flat (discharged).	Recharge the battery.
	Indicator light remains on brightly. Bridge terminals 30 and 50 briefly at the starter. The starter then runs.	Break in line between terminal 50 and starting switch or in line between terminal 30 and battery, or defective starting switch.	Repair the break; if necessary, renew the starting switch.
	Indicator light remains on brightly, but no connection between terminal 30 and positive pole of battery.	Pull-in winding of starter has burned out.	Renew starter, ensure good connection between terminal 30 at starter and positive battery pole (main lead to starter).
	Indicator light remains on brightly, solenoid switch is energised; starter runs when solenoid switch is bridged.	Solenoid switch contacts worn or dirty.	Renew solenoid switch.

Troubleshooting chart - electrical system

Troubleshooting at the starting equipment

Malfunction	Indication	Possible cause	Remedial action
Starter turns too slowly or is unable to turn the engine over.	Lengthy period of use without maintenance or in severe conditions.	Carbon brushes sticking.	Renew carbon brushes and brush holder guides.
		Carbon brushes worn.	Renew carbon brushes.
		Brush springs too weak, brushes not making contact.	Renew springs.
		Commutator dirty.	Clean commutator.
		Commutator scored or burned.	Recondition or renew starter.
		Armature or field coils defective.	Recondition or renew starter.
Starter engages and is energised, but engine turns over jerkily or not at all.	Lengthy period of use without maintenance, neglect of electrical system.	Battery flat (discharged).	Charge the battery.
		Insufficient current flow because of loose or oxidised connections.	Clean battery posts and terminals, tighten connections.
		Carbon brushes sticking.	Renew carbon brushes and brush holder guides.
		Carbon brushes worn.	Renew carbon brushes.
		Commutator dirty.	Clean commutator.
		Commutator scored or burned.	Recondition or renew starter.
		Armature or field coils defective.	Recondition or renew starter.
Drive pinion does not engage or disengage.	Engine turns over jerkily or not at all.	Drive pinion or helical thread dirty or damaged.	Renew drive pinion, recondition starter.
		Damaged flywheel gear ring.	Remachine or renew gear ring.
		Faulty solenoid switch.	Renew solenoid switch.
		Return spring weak or broken.	Renew return spring.

Troubleshooting chart - electrical system

Troubleshooting at the starting equipment

Malfunction	Indication	Possible cause	Remedial action
Starter continues to turn after switch has been released.	Noise of starter turning.	Preheat/starting switch does not return automatically from position 2 to position 1.	Reset the preheat/starting switch to 0 by force if necessary and renew it. If this is not possible, disconnect the battery immediately. Warning! If this action is not taken within 2 - 3 minutes, the starter will overheat and burn out.
Engine starts reluctantly or not at all although starter turns quickly.		Defective preheat system (this is only of significance at temperatures below -10°C).	Check the preheat circuit, renew defective parts if necessary.