

GENERAL PURPOSE ENGINE

GX200
GX200
[PROPANE ENGINE]

PARTS CATALOGUE

6



GX200

FOREWORD INDEX

1

ENGINE GROUP

2

PART NUMBER INDEX

3

PART NAME INDEX

4

Instruction for use of parts catalogue

- **This parts catalogue was prepared based on the latest information available as of August 20, 2004.**
 - See the parts catalogue news for any revision that is made after August 20, 2004.
- **Always specify the part number when ordering a part.**
 - Check the model, type, serial numbers, color, maker, and the size as needed before ordering a part.
 - Note that the illustrations (part drawings) can differ from the actual parts in shape. They are given just to help you to refer to the parts.
- **When modifications or additions to this parts catalogue are made, a revised edition will be issued at an appropriate time, with successively progressing revision numbers on the cover. We recommend obtaining such revisions in order to keep your parts catalogue up-to-date at all times. To check whether a parts catalogue revision has been issued, please contact your Honda distributor.**

Initial version issue date March 20, 1995
Honda Motor Co., Ltd.

CONTENTS

	Page	Address No.	
● How to refer to the part information	2	B 2	1
● Part catalogue structure	3	B 3	
● When the parts were revised	4	B 4	
● Abbreviations used in the parts catalogue.....	4	B 4	
● How to check the part block and serial numbers.....	5	B 5	
● Models, parts catalogue codes and applicable serial numbers	6	B 6	
● Features of each type.....	12	B12	
● Fuel hose, general purpose hoses and vinyl hose.....	23	C 7	
● FLAT RATE SERVICE TIME.....	24	C 8	
● Illustrated index	29	C13	
● ENGINE GROUP.....	34	E 1	2
● PART NO. INDEX.....	135	L 1	3
● PART NAME INDEX.....	139	M 1	4



How to refer to the part information

1

A Reference with "Illustrated index"

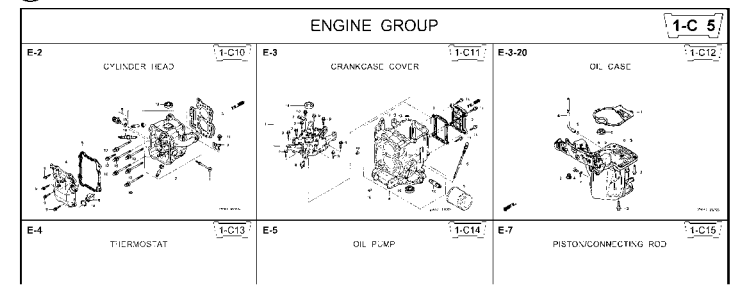

B Reference with "Part number index"

PART NO. INDEX

Part Number	Address	Page	Ref.	Part Number	Address	Page
06000				15212-ZW9-000	1-C14	3C
06316-ZW9-000	1-G9	88	1	15220-ZW9-003	1-C14	3C
11000				15332-ZW9-000	1-E8	55
11300-ZW9-405	1-C11	27	1	15332-ZW9-A30	1-E11	58
11300-ZW9-406	1-C11	27	1	15400-PFB-004	1-C11	27
11340-ZW9-000	1-C11	27	2	15422-ZW9-000	1-C14	3C
11342-ZW9-000	1-C11	27	3	15473-881-000	1-C14	3C
11381-ZW9-003	1-C12	28	1	15474-ZW9-000	1-C14	3C
				15611-921-000	1-C10	2E
				15655-ZW9-000	1-C11	27
				16000		
12000				16010-ZV4-005	1-D4	3E
12000-ZW9-405ZA	1-C11	27	4	16011-ZV4-005	1-D4	3E
12155-ZV4-A00	1-C13	29	1	16013-ZW9-003	1-D4	3E
12166-ZW9-000	1-C10	26	1	16016-ZW9-003	1-D4	3E
12209-GB4-681	1-C16	32	1	16016-ZW9-721	1-D4	3E
12210-ZW9-405ZA	1-C10	26	2	16023-ZW9-003	1-D4	3E
12216-ZE2-300	1-E8	55	1	16024-ZV4-650	1-D4	3E
	1-E11	58	1	16028-ZV4-650	1-D4	3E

C Reference with "Part name index"

PART NAME INDEX

Part name	Address	Page	Ref.
[A]			
ABSORBER , FUEL	1-E15	62	5
ARMATURE COMP.	1-D11	43	7
ARM COMP. , LINK JOINT	1-G6	85	18
ARM COMP. , SHIFT LINK	1-G6	85	14
ARM COMP. , TILT	1-F15	79	20
ARM , FUEL PUMP ROCKER	1-C16	32	4
ARM , REVERSE LOCK	1-F15	79	18
ARM , SHIFT LINK	1-F11	74	7
ARM , STOPPER	1-D1	33	12
ARM , THROTTLE REMOTE	1-F11	74	6
ARM , VALVE ROCKER	1-C16	32	3
[B]			
BAG , TOOL , 160MM	1-G5	84	10
BAND	1-G6	86	37
BAND B1 , WIRE	1-F6	69	1
BAND , CORD	1-F3	67	18
BAND , TUBE CLIP , 11MM	1-E15	63	20
BAND , TUBE CLIP , 12.5MM	1-E15	63	19

Address No. 1-C10

Block No. E-2

Ref No.

Service item F.R.T.

O-RING, 26X2.7	0.1
PLUG, SPARK	0.2
O-RING, 9.5X1.5	0.2
SENSOR ASSY., WATER TEMPERATURE	0.3
COVER COMP., HEAD	1.8
PACKING, HEAD COVER	1.8
GASKET, CYLINDER HEAD	2.4
OIL SEAL, 20X32X6	2.4
HEAD COMP., CYLINDER	3.1

Ref. No.	Part No.	Description	Reqd. QTY						Serial No.	Parts catalogue code
			9901	9901	1001	1001	1001	1001		
1	12166-ZW9-000	STOPPER, ENGINE SIDE	2	2	2	2	2			
2	12210-ZW9-000ZA	HEAD COMP., CYLINDER	1	1	1	1	1			
3	12251-ZW9-003	GASKET, CYLINDER HEAD	1	1	1	1	1			
4	12310-ZW9-000	COVER COMP., HEAD	1	1	1	1	1			
5	12312-ZW9-000	PACKING, HEAD COVER	1	1	1	1	1			
6	15611-921-000	CAP, OIL (NO GAUGE)	1	1	1	1	1			
7	16617-ZW9-000	HOLDER, CABLE	1	1	1	1	1	SC,SG		
	16617-ZW9-010		1	1	1	1	1	1001800 LHC,LHD		
			1	1	1	1	1	1001801	LHC,LHD	
8	35673-ZW5-003	SENSOR ASSY., WATER TEMPERATURE	1	1	1	1	1			
9	90003-ZW9-000	BOLT, FLANGE, 6X22	4	4	4	4	4			
10	90007-ZW9-003	BOLT, FLANGE, 8X83	6	6	6	6	6			
11	90011-ZW9-000	BOLT, FLANGE, 6X14 (CT200)	1	1	1	1	1			
12	90020-ZW9-000	BOLT, FLANGE, 8X40	2	2	2	2	2			
13	91203-K49-003	OIL SEAL, 20X32X6	1	1	1	1	1			
14	91301-805-000	O-RING, 26X2.7	1	1	1	1	1			
15	91307-PK2-005	O-RING, 9.5X1.5 (HONDA KIKAKI)	1	1	1	1	1			
16	98059-55916	PLUG, SPARK (CR5EH-D)	2	2	2	2	2			
	98059-55926	PLUG, SPARK (U16FER9)	2	2	2	2	2			

Page No. 2000.09.20 E

Part catalogue structure

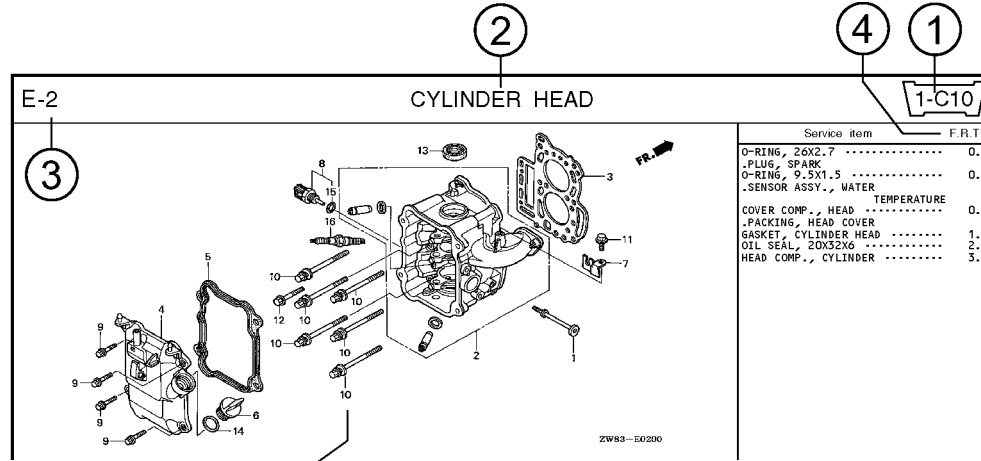

Ref. No.	Part No.	Description	Reqd. QTY						Serial No.	Parts catalogue code
			BF 93D1	BFP 93D1	BF 10D1	BFP 10D1	BF 10B1	BFP 10B1		
1	12166-zw9-000	STOPPER, ENGINE SIDE	2	2	2	2	2			
2	12210-zw9-000ZA	HEAD COMP., CYLINDER *NH8*	1	1	1	1	1			
3	12251-zw9-003	GASKET, CYLINDER HEAD	1	1	1	1	1			
4	12310-zw9-000	COVER COMP., HEAD	1	1	1	1	1			
5	12312-zw9-000	PACKING, HEAD COVER	1	1	1	1	1			
6	15611-921-000	CAP, OIL (NO GAUGE)	1	1	1	1	1			
7	16617-zw9-000 16617-zw9-010	HOLDER, CABLE	1	1	1	1	1	SC,SG 1001800 LHC,LHD		

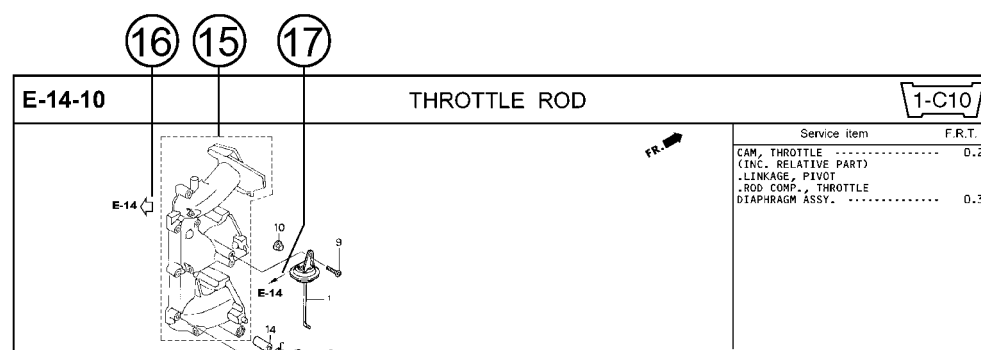

- ① **Address number**
 - Address No. is provided (in place of the page No.) to help you refer to the part with the part No. or part name.
- ② **Block title** ③ **Block number**
- ④ **Service item/Flat rate time**
- ⑤ **Reference number**
 - Title number marked with the parenthesis or parentheses indicates that it continues from the previous page.
- ⑥ **Part number** ⑦ **Honda color code**
- ⑧ **Description**
- ⑨ **Assemblies**
 - Sections framed with broken lines in the exploded view drawings are available as complete assemblies. (Their individual parts can also be obtained.)
- ⑩ **Color description**
- ⑪ **Note**
 - Notes are shown with the parentheses in the part name column.
- ⑫ **Required quantity**
 - Required QTY shown in the parenthesis or parentheses indicates the optional part.
 - Required QTY marked with "N" Indicates the optional part that should be selected as needed.
 - Required QTY indicates the number of the part used in the block.
- ⑬ **Serial number**
- ⑭ **Type**
 - When the type column is blank, it indicates that the part is applicable to all types.
 - As the type of the actual unit may differ from the "parts catalogue, type" please refer to "Models, types and applicable serial numbers" for confirmation.
- ⑮ **[Dotted box]**
 - Parts enclosed within a dotted line [] are covered in a different block.
- ⑯ **[Hollow arrow]**
 - A hollow arrow [] indicates the block No. for the parts enclosed within a dotted line [] .
- ⑰ **[Solid arrow]**
 - A solid arrow [] indicates the block No. the part in question is connected to.

When the parts were revised

Abbreviations used in the parts catalogue

1



Be sure to check the serial number!!



Ref. No.	Part No.	Description	Reqd. QTY						Serial No.
			BF 99D1	BFP 99D1	BF 10D1	BFP 10D1	BF 10B1	BFP 10B1	
1	12166-ZW9-000	STOPPER, ENGINE SIDE	2	2	2	2	2	2	
2	12210-ZW9-000ZA	HEAD COMP., CYLINDER *NH8*..... DARK GRAY	1	1	1	1	1	1	
3	12251-ZW9-003	GASKET, CYLINDER HEAD	1	1	1	1	1	1	
4	12310-ZW9-000	COVER COMP., HEAD	1	1	1	1	1	1	
5	12312-ZW9-000	PACKING, HEAD COVER	1	1	1	1	1	1	
6	15611-921-000	CAP, OIL (NO GAUGE)	1	1	1	1	1	1	
7	16617-ZW9-000	HOLDER, CABLE (###).....	1	1	1	1	1	1	
	16617-ZW9-010	1	1	1	1	1	1	



The number has been used from the initial model without revision. When shown at the left side, it is applicable to the models of No.1001801 and the subsequent numbers. When shown at the right side, it is applicable to the models up to No.1001800.

• The parts listed with "###" at the end of the parts name have limited supply period (parts not for sale).

• The following abbreviations are used in the parts name column.

- A Ampere
- A.C. Alternating current
- ASSY. Assembly
- AT. Automatic transmission
- C.D.I. Capacitive discharge ignition
- COMP. ... Complete
- D.C. Direct current
- EX. Exhaust
- G.F.C.I ... Ground fault circuit interruptor
- HEX. Hexagonal
- H.S.T. Hydrostatic transmission
- FR.Front
- IN.Inlet
- L (100L) .Link (100 Links)
- L.Left
- MMMillimeter
- MT.Manual Transmission
- P.T.O.Power take off
- R.Right
- RR.Rear
- STD.Standard
- T (22T) ...Tooth (22 Teeth)
- VVolt
- WWatt

How to check the part block and serial numbers

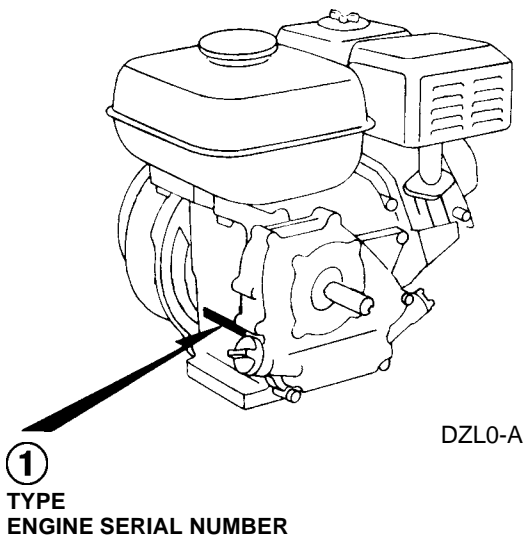
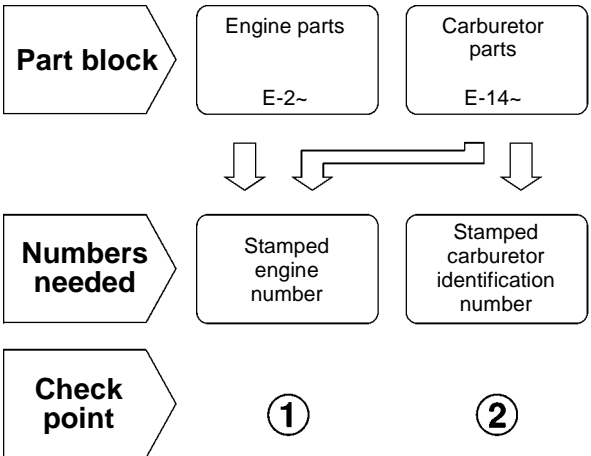

2-B
CARBURETOR
IDENTIFICATION NUMBER
GX200(1)(3)

2-A
CARBURETOR
IDENTIFICATION NUMBER
GX200(1)(3)

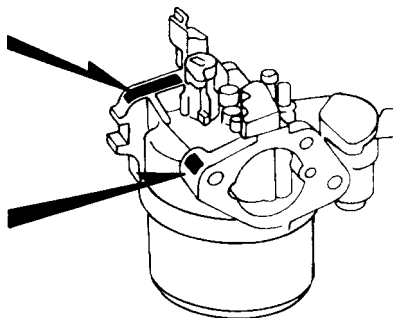

2
CARBURETOR
IDENTIFICATION NUMBER
GX200(2)

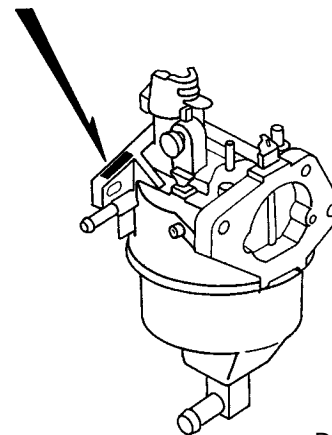

Models, parts catalogue codes and applicable serial numbers

- Models, parts catalogue codes and applicable serial Nos. given in this parts catalogue can be identified as follows.

Model	Type	Parts catalogue type	Applicable engine serial No.	Applicable carburetor identification No.
GX200 (1)	BL	BL	GCAE-1000001~1899999	BE64S A
	HX	HX		BE64A A/B, BE64B B
	HXQ	HXQ	GCAE-1000001~1349731	BE64D A/B
	HXU	HXU	GCAE-1000001~1899999	BE64A B, BE64B B
	HX2	HX2		BE64B A/B
	HX26	HX26		BE64A A/B, BE64B B
	HX4	HX4		BE69A A/B
	LD	LD		
	LDB1	LDB1	GCAE-1000001~1179315	BE64C B
	LDB2	LDB2	GCAE-1000001~1349731	
	LDN	LDN		BE69A A/B
	LD4	LD4	GCAE-1000001~1899999	BE64A A/B, BE64B B
	LH	LH		BE64A B, BE64B B
	LHB2	LHB2		BE64A A/B, BE64B B
	LHP1	LHP1		BE64C A/B
	LHQ4	LHQ4		BE64C B
	LJ	LJ		BE64C A/B
	LJC1	LJC1		BE64S A
	LJG	LJG		BE64A A/B, BE64B B
	LSJ	LSJ		BE64B A/B
	LVL	LVL		BE64A A/B, BE64B B
	LX	LX		BE64B A/B
	LX2	LX2		BE64A A/B, BE64B B
LX4	LX4	BE64C A/B		
NAX	NAX			
NAX1	NAX1			

Model	Type	Parts catalogue type	Applicable engine serial No.	Applicable carburetor identification No.
GX200 (1)	NDF1	NDF1	GCAE-1000001~1899999	BE64A B, BE64B B
	NDJ	NDJ		BE64A B, BE64B B, BE64E B
	NJ	NJ		BE64C A/B
	NJC1	NJC1		BE64C B, BE64U A
	NJG	NJG		BE64C A/B
	NMB	NMB		
	NTB	NTB		
	NTU	NTU		BE64C B
	NW	NW		
	NWA	NWA		
	NWB2	NWB2		
	NX	NX		BE64A A/B, BE64B B
	PMX	PMX		BE64A B, BE64B B
	PX	PX		BE64A A/B, BE64B B
	PXU	PXU		BE64A B, BE64B B
	PX2	PX2	BE64B A/B	
	QA	QA	GCAE-1000001~1349731	BE64C A/B
	QAB2	QAB2	GCAE-1000001~1899999	BE64C A/B, BE64E B
	QA2	QA2		BE64E A/B
	QD	QD		BE69A A/B
	QG	QG		BE64A B
	QG2	QG2		BE64B B
	QH	QH		BE64A A/B, BE64B B
	QHP1	QHP1		BE64A B, BE64B B
	QHQ4	QHQ4		BE64A A/B, BE64B B
	QH26	QH26		BE64B A/B

Model	Type	Parts catalogue type	Applicable engine serial No.	Applicable carburetor identification No.
GX200 (1)	QH4	QH4	GCAE-1000001~1899999	BE64F B
	QJF	QJF		BE64C B
	QJF1	QJF1		BE64C B, BE64U A
	QM	QM		BE69A A/B
	QSW4	QSW4		BE64A B, BE64B B
	QT	QT		BE64C A/B
	QTP	QTP		BE64A B, BE64B B
	QTP2	QTP2		BE64F B
	QVL	QVL		BE64S A
	QX	QX		BE64A A/B, BE64B B
	QXB2	QXB2		BE64B B
	QXC	QXC		BE64G A/B, BE64F B
	QXC9	QXC9		BE64F A/B
	QXE	QXE	GCAE-1000001~1349731	BE64A A/B
	QXE2	QXE2	GCAE-1000001~1899999	BE64B A/B
	QXE4	QXE4		BE64A A/B, BE64B B
	QXE6	QXE6		BE64B A/B
	QXE8	QXE8		BE64B B
	QXF	QXF	GCAE-1000001~1349731	BE64A A/B
	QXF2	QXF2	GCAE-1000001~1899999	BE64B A/B
	QXH4	QXH4		BE64F B
	QXQ	QXQ	GCAE-1000001~1349731	BE64D A/B
	QXS2	QXS2	GCAE-1000001~1899999	BE64B A/B
	QXU	QXU		BE64A B, BE64B B
	QX2	QX2		BE64B A/B
	QX26	QX26		

Model	Type	Parts catalogue type	Applicable engine serial No.	Applicable carburetor identification No.	
GX200 (1)	QX4	QX4	GCAE-1000001~1899999	BE64A A/B, BE64B B	
	QX7	QX7		BE64B B	
	RG	RG		BE64A B	
	RH	RH		BE64A A/B, BE64B B	
	RHA2	RHA2		BE64B A/B	
	RHQ4	RHQ4		BE64A A/B, BE64B B	
	RH2	RH2		BE64B A/B	
	RH26	RH26		BE64B B	
	RMG2	RMG2		BE64A A/B, BE64B B	
	RX	RX		BE64A B, BE64B B	
	RXU	RXU		BE64B B	
	RX2	RX2		BE64A A/B, BE64B B	
	RX4	RX4		BE69A A/B	
	SD	SD		BE64C B	
	SDB1	SDB1		GCAE-1000001~1899999	BE69A A/B
	SDB2	SDB2	BE64A A/B, BE64B B		
	SDN	SDN	GCAE-1000001~1097524		BE64C B
	SD4	SD4	BE69A A/B		
	SH	SH	BE64A A/B, BE64B B		
	SHQ4	SHQ4	BE64C A/B		
	SJ	SJ	BE64A A/B, BE64B B		
	SJG	SJG	BE64R A/B		
	SMC4	SMC4	BE64T A		
	SMG1	SMG1	BE64B B		
	SMG2	SMG2			
	SM11	SM11			

Model	Type	Parts catalogue type	Applicable engine serial No.	Applicable carburetor identification No.
GX200 (1)	SM12	SM12	GCAE-1000001~1899999	BE64B B
	SM14	SM14		BE64A B, BE64B B
	SM21	SM21		BE64B B
	SM22	SM22		BE64A B, BE64B B
	SM24	SM24		BE64B B
	SWG4	SWG4		BE64A A/B, BE64B B
	SX	SX		BE64A B, BE64B B
	SXE4	SXE4		BE64A A/B, BE64B B
	SXU	SXU		BE64B B
	SX4	SX4		BE64A A/B, BE64B B
	SX7	SX7		BE64A A/B, BE64B B
	TX	TX		BE64B B
	TXE	TXE	GCAE-1000001~1176170	BE64A A/B, BE64B B
	TXU	TXU	GCAE-1000001~1899999	BE64A B, BE64B B
	TXU1	TXU1		BE64B A/B
	TX2	TX2	GCAE-1000001~1349731	BE64A A/B
	TX4	TX4		
	UX	UX	GCAE-1000001~1899999	BE74A B
	VAA	VAA		BE64B A/B
	VAA1	VAA1		BE64C B, BE64B B
	VA2	VA2		BE74A B
	VEE1	VEE1		BE64B B
	VEN	VEN		
VEN1	VEN1			
VEN4	VEN4	BE74A B		
VES	VES			

Model	Type	Parts catalogue type	Applicable engine serial No.	Applicable carburetor identification No.
GX200 (1)	VES1	VES1	GCAE-1000001~1899999	BE64B B
	VGG2	VGG2		BE64N A
	VMG1	VMG1		BE64A B, BE64B B
	VMT	VMT		BE74A B
	VNG4	VNG4		BE64A B, BE64B B
	VSD	VSD		BE64A A/B, BE64B B
	VSD1	VSD1		BE74A B
	VSD2	VSD2		BE74H A
	VSD7	VSD7		BE64B B
	VS17	VS17		BE74A B
	VX	VX		BE64A A/B, BE64B B
	VXU	VXU		BE64A B, BE64B B
	VXU1	VXU1		BE64B A/B
	VX2	VX2		BE64A A/B, BE64B B
VX4	VX4			
GX200 (2) (Propane)	VXP	VXP	GDAB-1000001~1009999	BEL1A A
	VX4P	VX4P	GDAB-1000001~1000107	
GX200 (3) (Indonesia-KD)	LDNI	LDNI	GCAE-9000001~9999999	BE64C B

* Of carburetor identification numbers, only the portions underlined in the example below are used for registration.

GX200(1)(3) BE 64S A KC ナ

A B

GX200(2) BEL1A A KC ナ

Features of each type

• See the following table for the features of each type.

Specifications		Model	GX200 (1)												
		Type	Standard equipment												
			BL	HX	HXQ	HXU	HX2	HX26	HX4	LD	LDB1	LDB2	LDN	LD4	LH
Crankshaft	20mmØ Spline								•	•	•	•	•	•	•
	21mmØ Spline		•	•	•	•	•	•							
	19mmØ Straight														
	20mmØ Straight														
	3/4" Thread														
	5/8" Thread														
	1/2" Stepped thread														
	3/16" Tapered														
	1/5" Tapered	•													
	Without P.T.O.														
Camshaft	Without P.T.O.	•	•	•	•	•	•	•	•	•	•	•	•	•	•
	With P.T.O.														
Starter motor															
Charge coil															
Lamp coil															
Air cleaner	Dual		•	•	•	•	•	•						•	•
	Semi dry								•	•	•	•	•		
	Cyclone														
	Oil bath	•													
	Standard														

1

Specifications		GX200 (1)													
		Standard equipment													
		Type	LHP1	LHQ4	LJ	LJC1	LJG	LSJ	LVL	LX	LX2	LX4	NAX	NAX1	NDF1
Crankshaft	20mmØ Spline	•	•	•	•	•	•	•	•	•	•				
	21mmØ Spline														
	19mmØ Straight														
	20mmØ Straight														
	3/4" Thread														
	5/8" Thread														
	1/2" Stepped thread														
	3/16" Tapered														
	1/5" Tapered														
	Without P.T.O.											•	•	•	•
Camshaft	Without P.T.O.	•	•	•	•	•	•	•	•	•	•				
	With P.T.O.											•	•	•	•
Starter motor													•		
Charge coil													•		
Lamp coil												•			
Air cleaner	Dual	•	•						•	•	•			•	•
	Semi dry			•	•	•	•					•	•		
	Cyclone														
	Oil bath							•							
	Standard														

Specifications		Model	GX200 (1)															
		Type	Standard equipment															
			NJ	NJC1	NJG	NMB	NTB	NTU	NW	NWA	NWB2	NX	PMX	PX	PXU	PX2		
Crankshaft	20mmØ Spline																	
	21mmØ Spline																	
	19mmØ Straight																	
	20mmØ Straight																	
	3/4" Thread											•	•	•	•			
	5/8" Thread																	
	1/2" Stepped thread																	
	3/16" Tapered																	
	1/5" Tapered																	
	Without P.T.O.	•	•	•	•	•	•	•	•	•	•	•						
Camshaft	Without P.T.O.											•	•	•	•			
	With P.T.O.	•	•	•	•	•	•	•	•	•	•							
Starter motor			•		•		•											
Charge coil			•		•		•											
Lamp coil						•			•									
Air cleaner	Dual										•	•	•	•	•			
	Semi dry	•	•	•	•	•	•											
	Cyclone																	
	Oil bath							•	•	•								
	Standard																	

Specifications		GX200 (1)														
		Model	Standard equipment													
		Type	QA	QAB2	QA2	QD	QG	QG2	QH	QHP1	QHQ4	QH26	QH4	QJF	QJF1	QM
Crankshaft	20mmØ Spline															
	21mmØ Spline															
	19mmØ Straight	•	•	•	•	•	•	•	•	•	•	•	•	•	•	
	20mmØ Straight															
	3/4" Thread															
	5/8" Thread															
	1/2" Stepped thread															
	3/16" Tapered															
	1/5" Tapered															
	Without P.T.O.															
Camshaft	Without P.T.O.	•	•	•	•	•	•	•	•	•	•	•	•	•	•	
	With P.T.O.															
Starter motor												•				
Charge coil							•					•				
Lamp coil																
Air cleaner	Dual					•	•	•	•	•	•					
	Semi dry				•								•	•	•	
	Cyclone											•				
	Oil bath	•	•	•												
	Standard															

Specifications		GX200 (1)													
		Standard equipment													
		Model	Type												
		QSW4	QT	QTP	QTP2	QVL	QX	QXB2	QXC	QXC9	QXE	QXE2	QXE4	QXE6	QXE8
Crankshaft	20mmØ Spline														
	21mmØ Spline														
	19mmØ Straight	•	•	•	•	•	•	•	•	•	•	•	•	•	•
	20mmØ Straight														
	3/4" Thread														
	5/8" Thread														
	1/2" Stepped thread														
	3/16" Tapered														
	1/5" Tapered														
	Without P.T.O.														
Camshaft	Without P.T.O.	•	•	•	•	•	•	•	•	•	•	•	•	•	•
	With P.T.O.														
Starter motor		•			•						•	•	•	•	•
Charge coil		•			•						•	•	•	•	•
Lamp coil				•											
Air cleaner	Dual	•		•			•	•			•	•	•	•	•
	Semi dry														
	Cyclone				•				•	•					
	Oil bath		•			•									
	Standard														

Specifications		GX200 (1)													
		Model	Standard equipment												
		Type	QXF	QXF2	QXH4	QXQ	QXS2	QXU	QX2	QX26	QX4	QX7	RG	RH	RHA2
Crankshaft	20mmØ Spline														
	21mmØ Spline														
	19mmØ Straight	•	•	•	•	•	•	•	•	•	•				
	20mmØ Straight											•	•	•	•
	3/4" Thread														
	5/8" Thread														
	1/2" Stepped thread														
	3/16" Tapered														
	1/5" Tapered														
	Without P.T.O.														
Camshaft	Without P.T.O.	•	•	•	•	•	•	•	•	•	•	•	•	•	•
	With P.T.O.														
Starter motor				•											
Charge coil				•											
Lamp coil						•								•	
Air cleaner	Dual	•	•		•	•	•	•	•	•	•	•	•	•	•
	Semi dry														
	Cyclone			•											
	Oil bath														
	Standard														

Specifications		Model	GX200 (1)													
		Type	Standard equipment													
			RH2	RH26	RMG2	RX	RXU	RX2	RX4	SD	SDB1	SDB2	SDN	SD4	SH	SHQ4
Crankshaft	20mmØ Spline															
	21mmØ Spline															
	19mmØ Straight															
	20mmØ Straight	•	•	•	•	•	•	•	•	•	•	•	•	•	•	
	3/4" Thread															
	5/8" Thread															
	1/2" Stepped thread															
	3/16" Tapered															
	1/5" Tapered															
	Without P.T.O.															
Camshaft	Without P.T.O.	•	•	•	•	•	•	•	•	•	•	•	•	•	•	
	With P.T.O.															
Starter motor																
Charge coil																
Lamp coil				•												
Air cleaner	Dual	•	•	•	•	•	•	•						•	•	
	Semi dry								•	•	•	•	•			
	Cyclone															
	Oil bath															
	Standard															

Specifications		GX200 (1)														
		Model	Standard equipment													
		Type	SJ	SJG	SMC4	SMG1	SMG2	SM11	SM12	SM14	SM21	SM22	SM24	SWG4	SX	SXE4
Crankshaft	20mmØ Spline															
	21mmØ Spline															
	19mmØ Straight															
	20mmØ Straight	•	•	•	•	•	•	•	•	•	•	•	•	•	•	
	3/4" Thread															
	5/8" Thread															
	1/2" Stepped thread															
	3/16" Tapered															
	1/5" Tapered															
	Without P.T.O.															
Camshaft	Without P.T.O.	•	•	•	•	•	•	•	•	•	•	•	•	•	•	
	With P.T.O.															
Starter motor					•	•							•		•	
Charge coil					•	•									•	
Lamp coil				•												
Air cleaner	Dual			•	•		•	•	•	•	•	•	•	•	•	
	Semi dry	•	•			•										
	Cyclone															
	Oil bath															
	Standard															

Specifications		GX200 (1)														
		Model	Standard equipment													
		Type	SXU	SX4	SX7	TX	TXE	TXU	TXU1	TX2	TX4	UX	VAA	VAA1	VA2	VEE1
Crankshaft	20mmØ Spline															
	21mmØ Spline															
	19mmØ Straight															
	20mmØ Straight	•	•	•												
	3/4" Thread															
	5/8" Thread				•	•	•	•	•	•						
	1/2" Stepped thread										•					
	3/16" Tapered											•	•	•		
	1/5" Tapered														•	
	Without P.T.O.															
Camshaft	Without P.T.O.	•	•	•	•	•	•	•	•	•	•	•	•	•	•	
	With P.T.O.															
Starter motor						•		•								
Charge coil						•		•								
Lamp coil																
Air cleaner	Dual	•	•	•	•	•	•	•	•	•	•			•	•	
	Semi dry														•	
	Cyclone															
	Oil bath															
	Standard											•	•			

Specifications		GX200 (1)															
		Model	Standard equipment														
		Type	VEN	VEN1	VEN4	VES	VES1	VGG2	VMG1	VMT	VNG4	VSD	VSD1	VSD2	VSD7	VS17	
Crankshaft	20mmØ Spline																
	21mmØ Spline																
	19mmØ Straight																
	20mmØ Straight																
	3/4" Thread																
	5/8" Thread																
	1/2" Stepped thread																
	3/16" Tapered						•			•	•	•	•	•	•		
	1/5" Tapered	•	•	•	•	•		•	•								
	Without P.T.O.																
Camshaft	Without P.T.O.	•	•	•	•	•	•	•	•	•	•	•	•	•			
	With P.T.O.																
Starter motor																	
Charge coil		•		•													
Lamp coil					•	•											
Air cleaner	Dual		•			•	•	•		•	•			•			
	Semi dry																
	Cyclone																
	Oil bath																
	Standard	•		•	•				•			•	•		•		

Specifications		Model	GX200 (1)					GX200 (2)		GX200 (3)
			Standard equipment					Propane		Indonesia-KD
		Type	VX	VXU	VXU1	VX2	VX4	VXP	VX4P	LDNI
Crankshaft	20mmØ Spline								•	
	21mmØ Spline									
	19mmØ Straight									
	20mmØ Straight									
	3/4" Thread									
	5/8" Thread									
	1/2" Stepped thread									
	3/16" Tapered	•	•	•	•	•	•	•		
	1/5" Tapered									
	Without P.T.O.									
Camshaft	Without P.T.O.	•	•	•	•	•	•	•	•	
	With P.T.O.									
Starter motor										
Charge coil										
Lamp coil										
Air cleaner	Dual	•	•	•	•	•	•	•		
	Semi dry								•	
	Cyclone									
	Oil bath									
	Standard									

Fuel hose, general purpose hoses and vinyl hose

- The standard part fuel hose, general purpose hose and vinyl hose may be substituted by the coiled bulk part.
- When ordering the standard part fuel hose, general purpose hose and vinyl hose use the bulk part number written in the parts catalog in brackets () underneath the part name.
- When exchanging the hose, cut and use at the specified length as mentioned in the part name.
(For the method of cutting the bulk part, and method of filling out orders etc., please refer to the instructions issued with the bulk part.)

Bulk part number of fuel hose, general purpose hose and vinyl hose.

Example: 9 5 0 0 1 - 7 5 0 0 1 - 5 0 M

Bulk part number:
Refers to the bulk part.

Marking code (fuel hose and general purpose hose)

Change code (Vinyl hose)

Indicates number mark or change sequence, however, the code for the bulk part must be strictly 0 (zero).

Types of code:

- | | | | | | |
|-------------|--|----------------|--|--------------|---|
| • Fuel hose | 2: Red outside braid
(3 mm inside dia. only) | • General hose | 1: Ash gray
2: Ash gray
3: Black
5: Black | • Vinyl hose | 1: Clear
2: Black
3: Light red
6: Light red
7: Pale black |
| | 5: Black inside braid | | | | |
| | 3: Red (3 mm inside dia. only) | | | | |
| | 4: Ash gray with red stripe
(3 mm inside dia. only) | | | | |
| | 6: Black | | | | |

Lengths:

- 001: 1 m (standard)
003: 3 m
008: 8 m } Application or specification of some parts is not settled.

I.D code: (fuel hose and general purpose hose)

- | | | | | |
|------------|--------------------|--------------------|-----------------------------|-----------------------------|
| 30: 3.0 mm | 50: 5.0 mm | 70: 7.0 mm | 11: 11 mm | 12: 12 (outside dia. 17) mm |
| 35: 3.5 mm | 55: 5.3 mm, 5.5 mm | 75: 7.3 mm, 7.5 mm | 91: 12 (outside dia. 15) mm | 14: 14 mm |
| 45: 4.5 mm | 65: 6.5 mm | 80: 8.0 mm | 92: 12 (outside dia. 16) mm | 17: 17 mm |

ID./OD. code: (vinyl hose)

- | | | | | |
|-------------------------|--------------------------|---------------------------|---------------------------|---------------------------|
| 01: ID. 2.9, OD. 6.8 mm | 12: ID. 5.0, OD. 7.0 mm | 21: ID. 8.0, OD. 9.0 mm | 37: ID. 11.0, OD. 15.0 mm | 50: ID. 16.0, OD. 19.0 mm |
| 03: ID. 3.0, OD. 6.0 mm | 10: ID. 5.0, OD. 8.0 mm | 23: ID. 8.0, OD. 12.0 mm | 38: ID. 12.0, OD. 13.0 mm | 55: ID. 17.5, OD. 20.5 mm |
| 05: ID. 3.5, OD. 6.5 mm | 11: ID. 5.0, OD. 9.0 mm | 25: ID. 9.0, OD. 11.0 mm | 39: ID. 12.0, OD. 14.0 mm | 60: ID. 22.0, OD. 27.0 mm |
| 07: ID. 4.0, OD. 7.0 mm | 14: ID. 6.0, OD. 9.0 mm | 27: ID. 9.0, OD. 13.0 mm | 40: ID. 12.0, OD. 16.0 mm | |
| 08: ID. 4.5, OD. 6.5 mm | 17: ID. 7.0, OD. 9.0 mm | 33: ID. 10.0, OD. 14.0 mm | 43: ID. 13.0, OD. 15.0 mm | |
| 09: ID. 4.5, OD. 8.0 mm | 19: ID. 7.0, OD. 11.0 mm | 36: ID. 11.0, OD. 13.0 mm | 45: ID. 14.0, OD. 18.0 mm | |

Hose type:

- 1: Fuel hose
3: Vinyl hose
5: General hose

⊙ **CAUTION: It is DANGEROUS to confuse the fuel hose with the general purpose hose or vinyl hose.**

Never use a general purpose hose or vinyl hose in place of a fuel hose or vice versa. Always use the correct bulk part in the parts catalogue, according to the service manual or the instructions issued with the bulk part.

FLAT RATE SERVICE TIME

Flat rate service time (FRT) means the standard time required to service a product, which is listed in this manual to help the dealers control the actual working process and calculate the service charge by using it as a guide.

FRT setting system

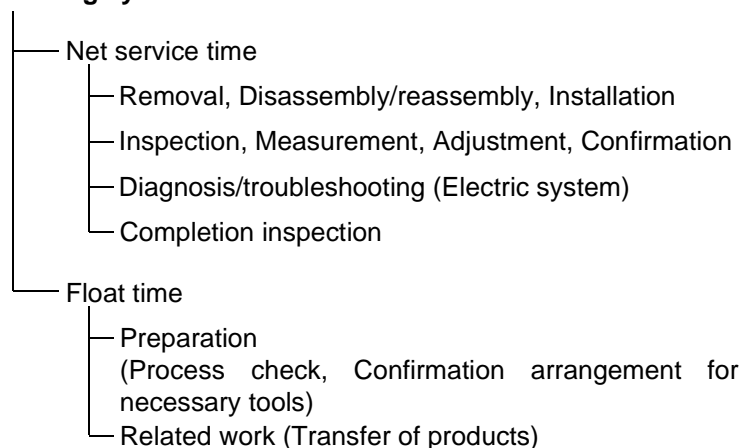

* Float time is set by multiplying the net service time by a given coefficient.

Editorial style

The service items shown in the text are listed with the exchange work time for the repair sales parts as the subject. Other representative service items not using repair parts (removal/installation, adjustment, inspection/measuring, and other work) are listed collectively in the list in the preface, classified according to the work.

FRT setting standard

- Decimal system (in unit of 0.1) is adopted to set FRT as it is convenient to calculate the wage.
Example: (0.1) → 6 minutes, (0.2) → 12 minutes
[Labor cost per hour] x [FRT] = [Wage]
- FRT is set with a hand tool.
- Service items and FRT can be subject to change depending on development of tools and service equipment and improvement in service procedure.

Work procedure

- As the work procedure is set with the work time according to the method in the separate Service Manual, refer to this Manual as required.
- Work methods permitting servicing in the shortest time still permitting assurance of safe work and product warranty are used for the setting of service items not listed in the Service Manual.
- Work basically is to be performed by one person, and when two or more people are required, setting is done as the total time for the number of people.
- The set value for the technological level of the workers uses a person with three years of experience in the repair of Honda products as the standard.
- Special tools and service equipment used to set FRT are those specified or recommended in Service Manual.

Service item whose FRT is not presented

- Accessories and service parts that are not listed to use in this manual.
 - Locations with little aging deterioration or breakage during normal use.
 - Service work that can be finished by one touch.
 - Service work that is seldom done (i.e. extremely small causes of trouble and service frequency).
 - Products and parts whose location for installation differs according to its status of use and application.
- * When FRT is not presented, please calculate wages based on appropriate actual work time.

Operation not included of FRT

- Oil and coolant water drainig, Waiting time for warming up operation and etc..
- Additional operation that involves removal/installation of standard exterior equipment.
- Indirect time spent for service by visiting the customer, trade-in, and delivery.
- Indirect time required for ordering and delivery of parts.
- Cost for grease, adhesive agent, etc. used for service work.

1

**Explanation of FRT by using an example
(The example may differ from the actual presented items)**

Ref. No.	L.O.N.	(Relative ref. Number) Description	F.R.T.
(1)	1111L1	(1, 3, 4, 7) VALVE, INTAKE4.1	(2)
(2)		• NOTE: OHV type (6)	(7)
(3)	1111L1A	• Includes: Engine removal and installation One head (intake all) add1.4	(5)

- ① Reference No. of the illustration of part that shows location of the replacement work.
- ② FRT is an abbreviation of Flat Rate Time indicating the standard service time required for the replacement.
- ③ LON is an abbreviation of Labor Operation Number, and it is a classification of the service items by the work unit code.

The same operation code is used regardless of the models.

Standard operation is indicated with 6 digits code, and additional operation is indicated with 7 digits code.

- ④ Indicating the intake valve replacement and FRT4.1.
- ⑤ Indicating FRT1.4 that will be added when additional operation (whole intake side of one cylinder head) is done in association with intake valve replacement.

- ⑥ Indicating work condition or application condition of the service item.
- ⑦ Indicating work contents that are included in the service item.
- ⑧ Indicating a reference No. whose operation and time are the same as FRT4.1 for the intake valve.

(The application range is limited to the service items without an LON setting within a same block.)

**How to refer to the service item by using the sample
(intake valve replacement)**

Open to the page of the block where the intake valve's spare part illustration is shown.

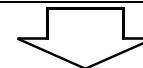

Look for the intake valve illustration, and refer to the service item and FRT that agree with the reference No.

Indication mark for the listing of service items that continues to the following page

Ref. No.	L.O.N.	(Relative ref. Number) Description	F.R.T.
2	1111L1	VALVE, INTAKE	4.1
	.	.	.
	.	.	.

+
Mark indicated at the last line.

Indication of the block with no setting of FRT

Ref. No.	L.O.N.	(Relative ref. Number) Description	F.R.T.
NO INFORMATION			

• LON code system

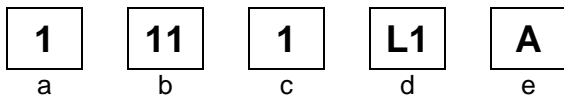

- a) Category code..... Engine
- b) Location/function code Engine upper
- c) Operation code..... Replace
- d) Operation sequence number (Unit code can be shown with alphabet)
..... Intake valve
(No regular rule of code)
- e) Additional code One head (intake all)
(No regular rule of code)

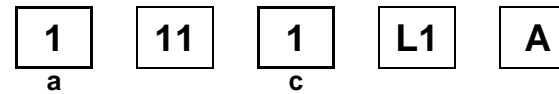

a) Category codes and classification

Code	Category
1	Engine
2	Power drive
3	Fuel & Exhaust
4	Frame & Body
5	Steering
6	Electrical
7	Axle & Brake
8	Control system
9	-
0	Attachments

c) Operation codes and classification

Code	Operation category
1	Replace, Removal/Installation, Change
2	Overhaul
3	Adjust, Rotation
4	(Paint-related work: Top-coat)
5	Test, Inspect/diagnose, Measurement
6	(Overhaul-related work: Rebore)
7	(Overhaul-related work: Reseal)
8	(Resurface)
9	(Paint-related work: Refinish)
0	Repair, Cleaning, Air bleeding



Major service items without using spare parts

(1) Removal/Installation, (2) Adjustment, (3) Inspection/Measurement, (4) Overhaul, (5) Other work

E: Engine, T: Transmission, D: Drive system, B: Body and related parts

(1) Removal/Installation

Set with the parts configuration in the status of being removed from the product.

	LON	DESCRIPTION	FRT
E	1111L3	CYLINDER HEAD ASSEMBLY-REMOVAL/INSTALLATION	0.5

(2) Adjustment

	LON	DESCRIPTION	FRT
E	1113A1	VALVE CLEARANCE-ADJUSTMENT NOTE: For 1 product	0.3
	1163A0	CONTROL, THROTTLE/GOVERNOR-ADJUSTMENT	0.2
	3113A2	CARBURETOR IDLE-ADJUSTMENT	0.2

(3) Inspection, Measurement, Cleaning

	LON	DESCRIPTION	FRT
E	1105A0	ENGINE OIL-INSPECTION	0.1
	3120A0	AIR CLEANER-CLEANING INCLUDES: Air cleaner-inspection	0.2
	3130A0	SPARK ARRESTER-CLEANING	0.2
	6140A0	SPARK PLUG-CLEANING INCLUDES: Spark plug gap-adjustment NOTE: For 1 product	0.2
	6145A0	SPARK-TEST NOTE: All cylinders	0.1

(4) Overhaul

Work condition: The required Measurements, inspections, adjustments, and cleaning/washing of each part are performed, including the main body removal/installation work and the replacement of defective parts.

	LON	DESCRIPTION	FRT
E	3112A0	CARBURETOR-OVERHAUL INCLUDES: All necessary adjustment	0.6

(5) Other work

	LON	DESCRIPTION	FRT
E	1101E1	ENGINE OIL-CHANGE INCLUDES: Engine oil-inspection	0.1

ENGINE GROUP

C13

E-2

CYLINDER HEAD

E 1

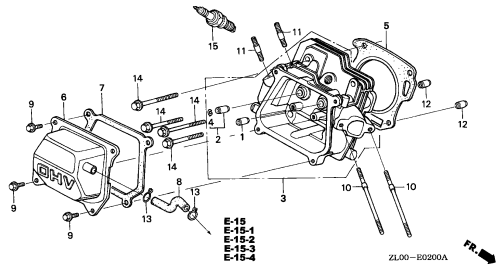

E-3

CYLINDER BARREL

E 5

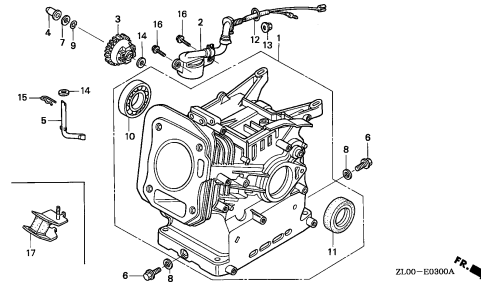

E-6

CRANKCASE COVER(1)

E 7

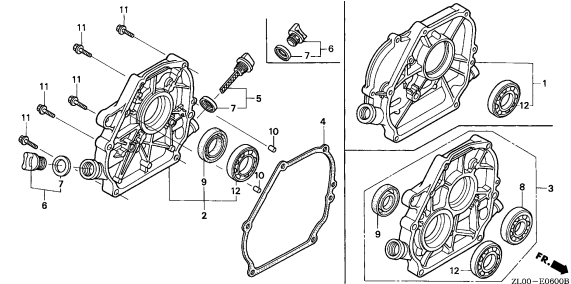

E-6-1

CRANKCASE COVER(2)(VMT)

E11

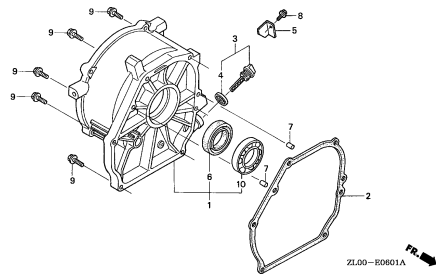

E-7

CRANKSHAFT

E12

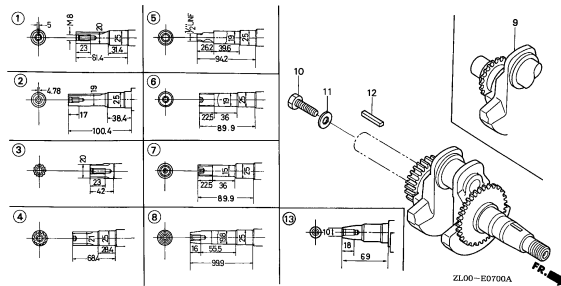

E-8

PISTON

E14

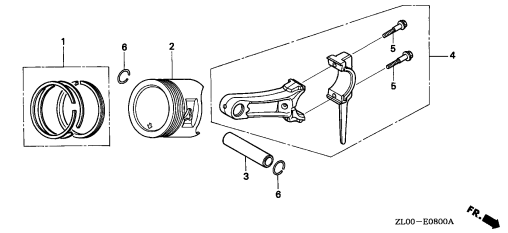

E-9

CAMSHAFT

F 1

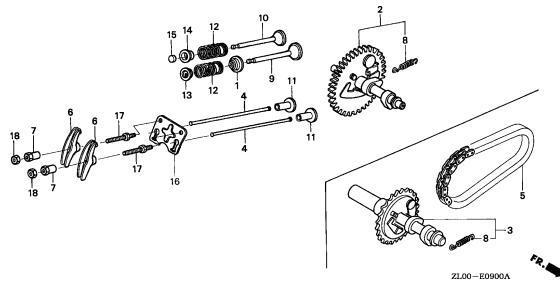

E-11

RECOIL STARTER(1)

F 5

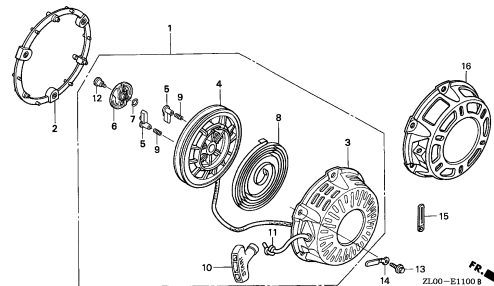

E-11-1

RECOIL STARTER(2)(LVL/QVL)

F11

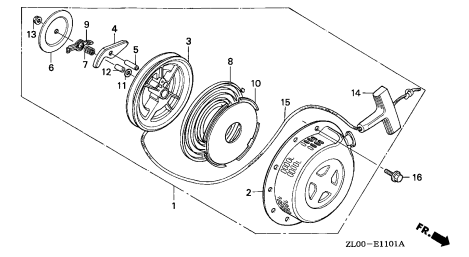

2

ENGINE GROUP

C14

E-12

FAN COVER

F12

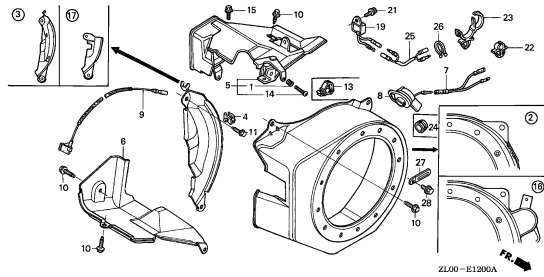

ZL00-E1200A

E-14

CARBURETOR(1)

G 1

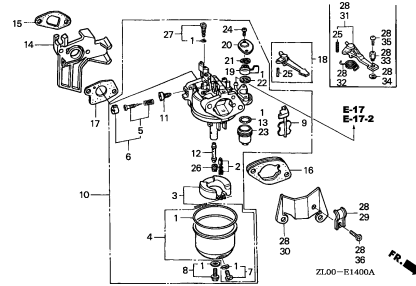

ZL00-E1400A

E-14-1

CARBURETOR(2)

G13

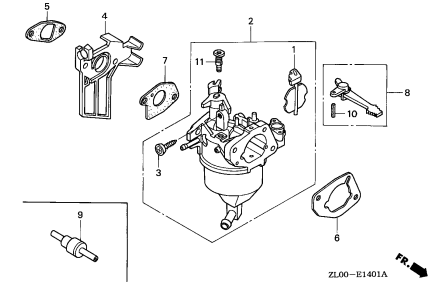

ZL00-E1401A

E-14-2

CARBURETOR(3)

G14

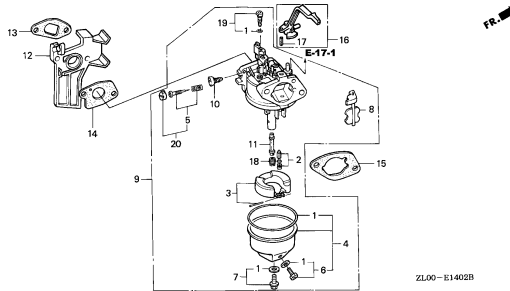

ZL00-E1402B

E-15

AIR CLEANER(DUAL)

G15

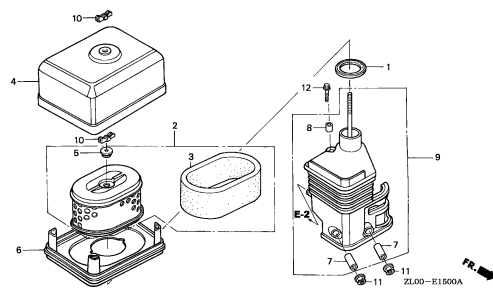

ZL00-E1500A

E-15-1

AIR CLEANER(SEMI DRY)

H 2

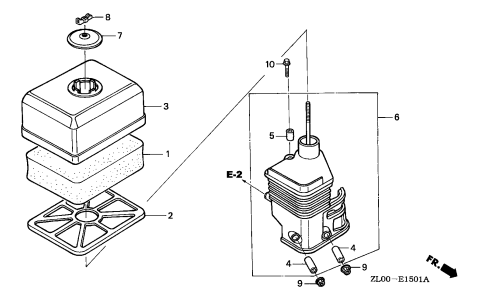

ZL00-E1501A

E-15-2

AIR CLEANER(CYCLONE)

H 4

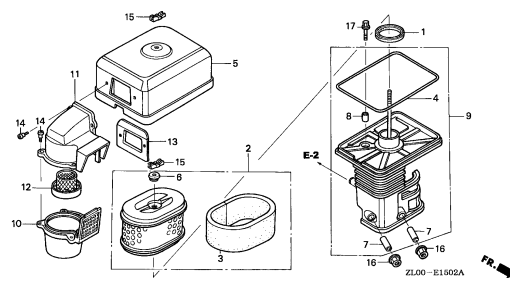

ZL00-E1502A

E-15-3

AIR CLEANER(OIL BATH)

H 5

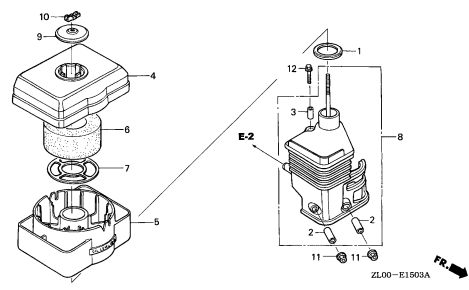

ZL00-E1503A

E-15-4

AIR CLEANER(STANDARD)

H 6

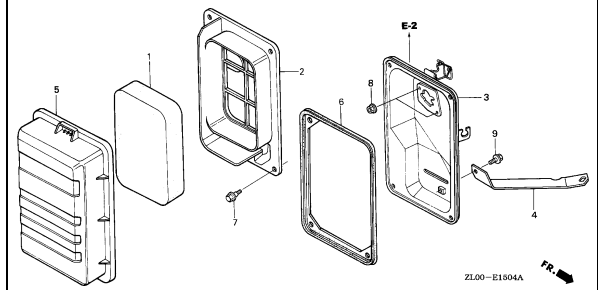

ZL00-E1504A

2

ENGINE GROUP

C15

E-16

MUFFLER(1)

H 7

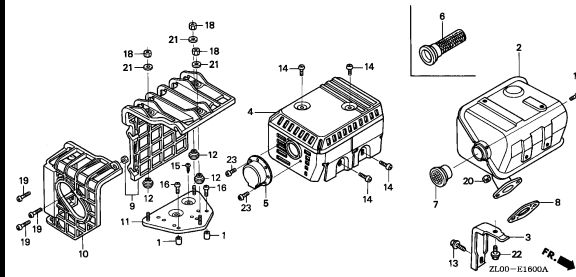

E-16-1

MUFFLER(2)

H11

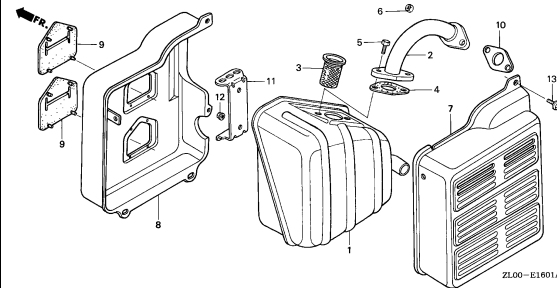

E-16-2

MUFFLER(3)(BL/LVL/QVL)

H12

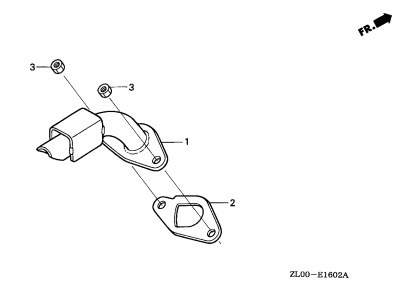

E-16-3

MUFFLER(4)(NJC1/QJF1)

H13

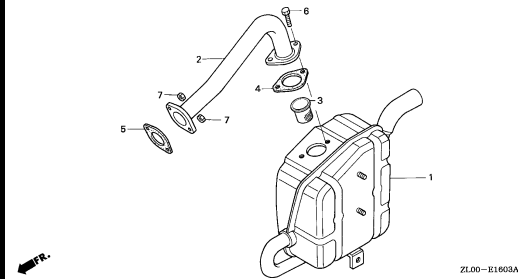

E-17

FUEL TANK(1)

H14

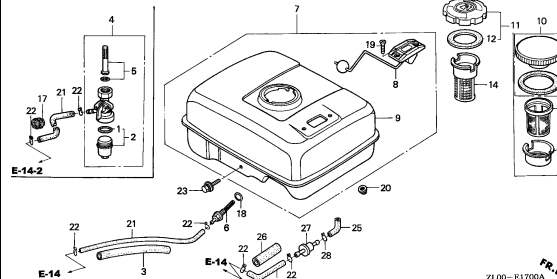

E-17-1

FUEL TANK(2)(VAA/VAA1/VMT)

I 3

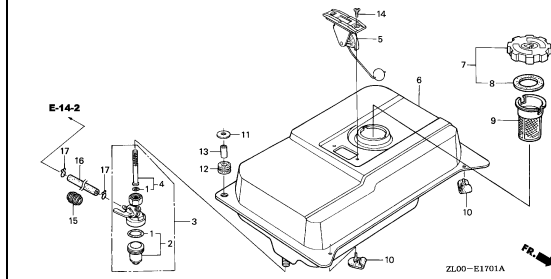

E-17-2

FUEL TANK(3)(NJC1/QJF1)

I 5

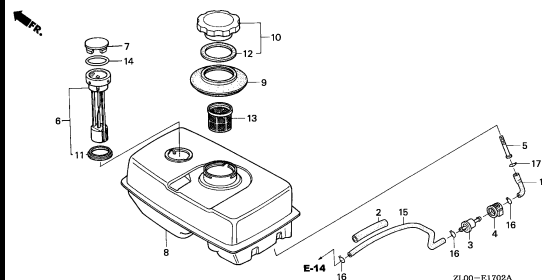

E-19

FLYWHEEL

I 6

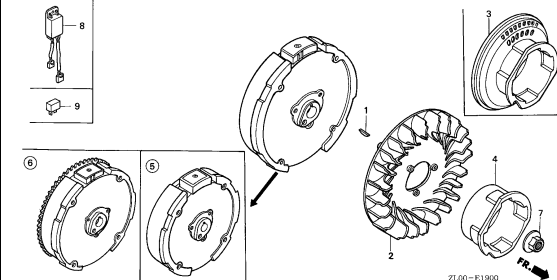

E-20

IGNITION COIL

I 8

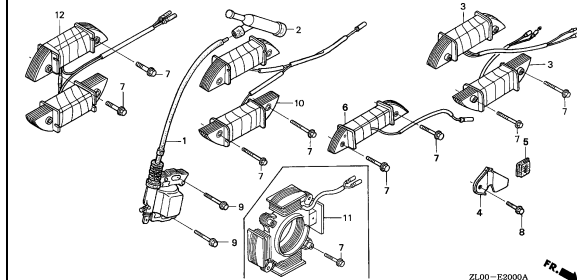

2

ENGINE GROUP

C16

E-21

STARTER MOTOR

I11

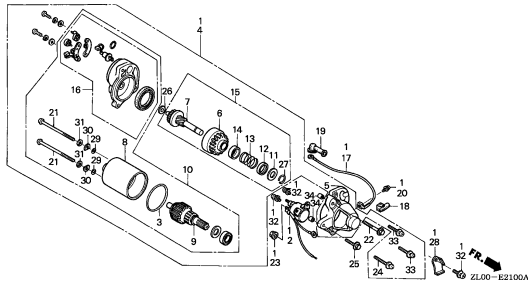

E-22

CONTROL

I13

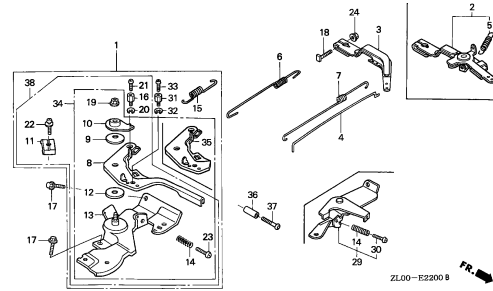

E-22-20

AUTO THROTTLE

J 5

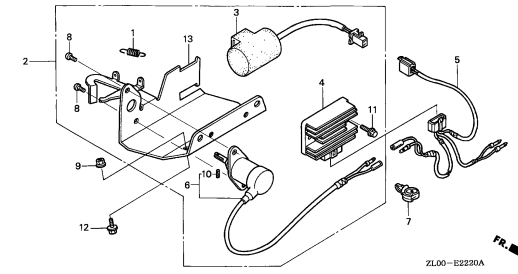

E-23

CONTROL BOX

J 6

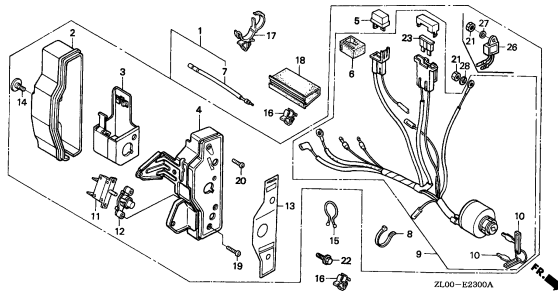

E-26

REDUCTION(1)

J 9

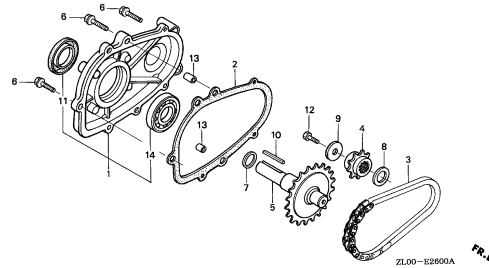

E-26-1

REDUCTION(2)

J11

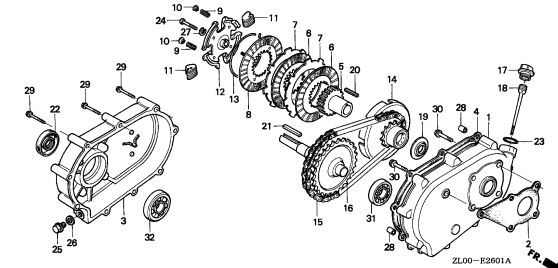

E-26-2

REDUCTION(3)

J13

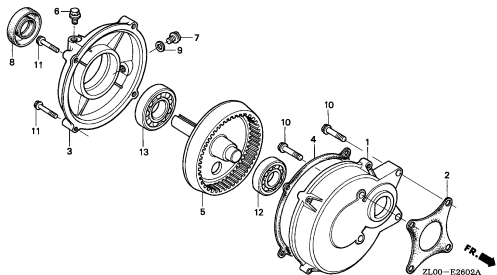

E-26-3

REDUCTION(4)

J14

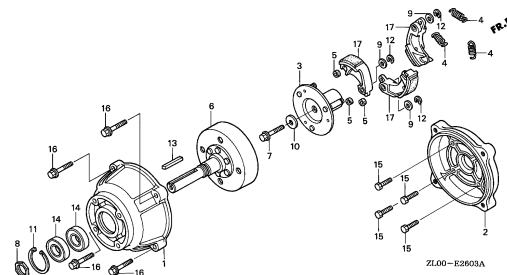

E-28

LABEL

J15

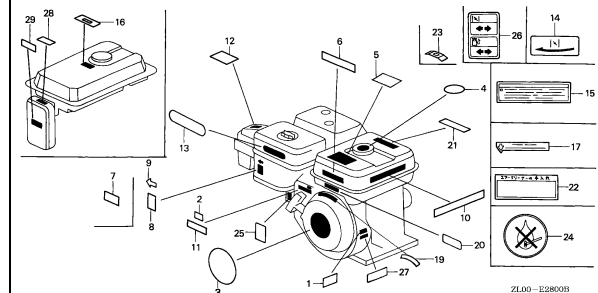

2

ENGINE GROUP

D 1

E-29

TOOL

K 2

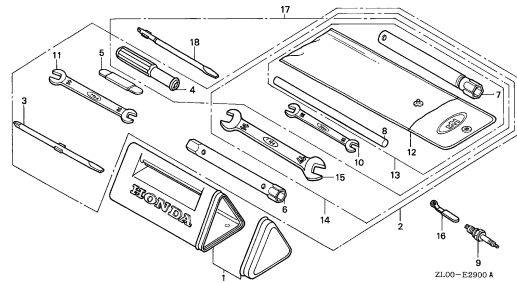

E-40

OTHER PARTS

K 4

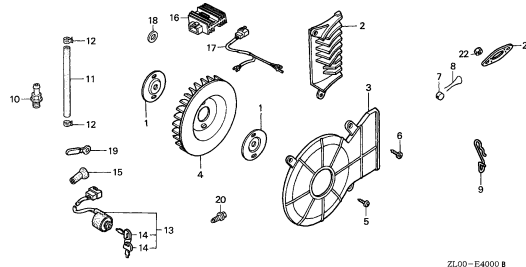

EOP-1

GASKET KIT

K 5

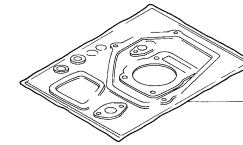

2

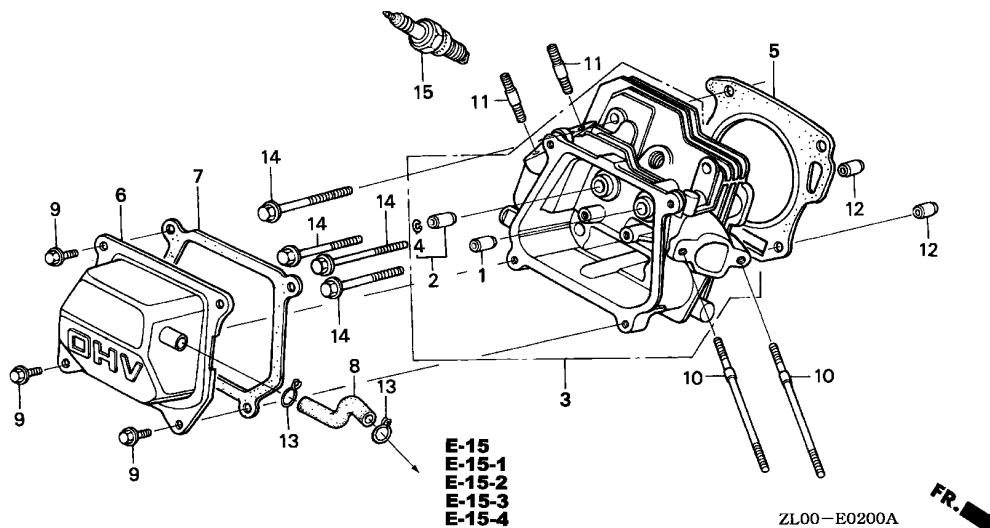

Ref. No.	L.O.N.	(Relative ref. Number) Description	F.R.T.
1	1111E9	GUIDE, INTAKE VALVEINCLUDES: Valve clearance adjustment	0.8
	1111E9E	.With intake and exhaust all add	0.2
2	1111E8	GUIDE, EXHAUST VALVEINCLUDES: Valve clearance adjustment	0.8
	1111E8E	.With intake and exhaust all add	0.2
3	1111N3	HEAD, CYLINDERINCLUDES: Valve clearance adjustment and reface	0.9
5	1111N4	GASKET, CYLINDER HEAD	0.5
6	1111D5	COVER, CYLINDER HEAD AND/OR PACKING, HEAD COVER	0.1
8	1111K5	TUBE, BREATHER	0.1
10	1111A5	BOLT, STUD :INTAKE	0.2
	1111A5A	.For two add	0.1
11	1111A6	BOLT, STUD :EXHAUST	0.2
	1111A6A	.For two add	0.1
15	6141C1	PLUG, SPARK	0.1

E-15
E-15-1
E-15-2
E-15-3
E-15-4

ZL00-E0200A



Ref. No.	Part No.	Description	Reqd. QTY			Serial No.	Parts catalogue code	
			GX200	(1)	(2)			(3)
1	12204-ZE1-306	GUIDE, IN. VALVE (O.S.)	(1)	(1)	(1)			
2	12205-ZE1-315	GUIDE, EX. VALVE (O.S.)	(1)	(1)	(1)			
3	12210-ZL0-000	HEAD COMP., CYLINDER	1	1	-	HXQ, HX4, LD, LDB1, LDB2, LDN, LD4, LSJ, LX, NAX, NAX1, NDF1, NWA, NWB2, PMX, PX2, QA, QA2, QG, QSW4, QT, QXC, QXE, QXF, QXF2, QXQ, RG, SDB1, SDN, SD4, TXE, TX4, UX, VAA, VAA1, VA2, VNG4, VX4P		
	12210-ZL0-405	-	-	1	BL, HX, HXU, HX2, HX26, LH, LHB2, LHP1, LHQ4, LJ, LJC1, LJG, LVL, LX2, LX4, NDJ, NJ, NJC1, NJG, NMB, NTB, NTU, NW, NX, PX, PXU, QAB2, QD, QG2, QH, QHP1, QHQ4, QH26, QH4, QJF, QJF1, QM, QTP, QTP2, QVL, QX, QXB2, QXC9, QXE2, QXE4, QXE6, QXE8, QXH4, QXS2, QXU, QX2, QX26, QX4, QX7, RH, RHA2, RHQ4, RH2, RH26, RMG2, RX, RXU, RX2, RX4, SD, SDB2, SH, SHQ4, SJ, SJG, SMC4, SMG1, SMG2, SM11, SM12, SM14, SM21, SM22, SM24, SWG4, SX, SXE4, SXU, SX4, SX7, TX, TXU, TXU1, TX2, VEE1, VEN, VEN1, VEN4, VES, VES1, VGG2, VMG1, VMT, VSD, VSD1, VSD2, VSD7, VS17, VX, VXP, VXU, VXU1, VX2, VX4		
4	12216-ZE5-300	CLIP, VALVE GUIDE	1	1	1			
5	12251-ZL0-003	GASKET, CYLINDER HEAD	1	1	1			
6	12310-ZE1-010	COVER COMP., HEAD	1	1	-	HX4, LD, LDB1, LDB2, LDN, LD4, LSJ, LX, NAX, NAX1, NWA, NWB2, PX2, QA, QA2, QG, QSW4, QT, QXE, QXF, QXF2, RG, SDB1, SDN, TXE, TX4, UX, VAA, VAA1, VA2, VNG4, VX4P		
			1	-	-	1627995	BL, HX, HXU, HX2, HX26, LH, LHB2, LHP1, LHQ4, LJ, LJC1, LJG, LX2, LX4, NDF1, NDJ, NJ, NJC1, NJG, NMB, NTB, NTU, NW, NX, PMX, PX, PXU, QAB2, QD, QG2, QH, QHP1, QHQ4, QH26, QJF, QM, QTP, QX, QXE2, QXE4, QXE6, QXS2, QXU, QX2, QX26, QX4, RH, RHA2, RHQ4, RH2, RH26, RMG2, RX, RXU, RX4, SD, SDB2, SD4, SH, SHQ4, SJ, SJG, SMC4, SMG1, SMG2, SM11, SM12, SM14, SM21, SM22, SM24, SX, SXE4, SXU, SX4, TX, TXU, TXU1, TX2, VEE1, VEN, VEN4, VES, VES1, VGG2, VMG1, VMT, VSD, VSD1, VX, VXU, VXU1, VX2, VX4	
			-	1	-	1000127	VXP	
			-	-	1			

Ref. No.	Part No.	Description	Reqd. QTY			Serial No.	Parts catalogue code
			(1)	GX200 (2)	(3)		
(6)	12310-ZE1-841	COVER COMP., HEAD (BREATHER TUBE)	1	-	-	-----	HXQ,QXQ
	12310-ZE1-020	COVER COMP., HEAD	1	-	-	-----	LVL,QJF1,QVL,QXB2,QXE8,QX7,RX2,SWG4,SX7,VEN1,VSD2,VSD7,VS17
			1	-	1627996	-----	BL,HX,HXU,HX2,HX26,LH,LHB2,LHP1,LHQ4,LJ,LJC1,LJG,LX2,LX4,NDF1,NDJ,NJ,NJC1,NJG,NMB,NTB,NTU,NW,NX,PMX,PX,PXU,QAB2,QD,QG2,QH,QHP1,QHQ4,QH26,QJF,QM,QTP,QX,QXE2,QXE4,QXE6,QXS2,QXU,QX2,QX26,QX4,RH,RHA2,RHQ4,RH2,RH26,RMG2,RX,RXU,RX4,SD,SDB2,SD4,SH,SHQ4,SJ,SJG,SMC4,SMG1,SMG2,SM11,SM12,SM14,SM21,SM22,SM24,SX,SXE4,SXU,SX4,TX,TXU,TXU1,TX2,VEE1,VEN,VEN4,VES,VES1,VGG2,VMG1,VMT,VSD,VSD1,VX,VXU,VXU1,VX2,VX4
	12310-ZE1-842	COVER COMP., HEAD (BREATHER TUBE)	-	1	1000128	-----	VXP
			1	-	-	-----	QH4,QTP2,QXC,QXC9,QXH4
7	12391-ZE1-000	PACKING, HEAD COVER	1	1	1		
8	15721-ZE1-840	TUBE, BREATHER	1	-	-	-----	HXQ,QH4,QTP2,QXC,QXC9,QXH4,QXQ
	15721-ZH8-000	1	-	-	-----	BL,HX,HXU,HX2,HX26,HX4,LD,LDB1,LDB2,LDN,LD4,LH,LHB2,LHP1,LHQ4,LJ,LJC1,LJG,LSJ,LVL,LX,LX2,LX4,NAX,NAX1,NDF1,NDJ,NJ,NJC1,NJG,NMB,NTB,NTU,NW,NWA,NWB2,NX,PMX,PX,PXU,PX2,QA,QAB2,QA2,QD,QG,QG2,QH,QHP1,QHQ4,QH26,QJF,QJF1,QM,QSW4,QT,QTP,QVL,QX,QXB2,QXE,QXE2,QXE4,QXE6,QXE8,QXF,QXF2,QXS2,QXU,QX2,QX26,QX4,QX7,RG,RH,RHA2,RHQ4,RH2,RH26,RMG2,RX,RXU,RX2,RX4,SD,SDB1,SDB2,SDN,SD4,SH,SHQ4,SJ,SJG,SMC4,SMG1,SMG2,SM11,SM12,SM14,SM21,SM22,SM24,SWG4,SX,SXE4,SXU,SX4,SX7,TX,TXE,TXU,TXU1,TX2,TX4,UX,VA2,VEE1,VEN1,VES1,VGG2,VMG1,VNG4,VSD,VSD7,VX,VXU,VXU1,VX2,VX4
	15721-883-030	-	1	1		
9	90013-883-000	BOLT, FLANGE, 6X12(CT200) ...	1	-	-	-----	VAA,VAA1,VEN,VEN4,VES,VMT,VSD1,VSD2,VS17
10	90043-ZE1-020	BOLT, STUD, 6X112	4	4	4		
			2	-	-	-----	BL,HX,HXQ,HXU,HX2,HX26,HX4,LD,LDB1,LDB2,LDN,LD4,LH,LHB2,LHP1,LHQ4,LJ,LJC1,LJG,LSJ,LVL,LX,LX2,LX4,NAX,NAX1,NDF1,NDJ,NJ,NJC1,NJG,NMB,NTB,NTU,NW,NWA,NWB2,NX,PMX,PX,PXU,PX2,QA,QAB2,QA2,QD,QG,QG2,QH,QHP1,QHQ4,QH26,QH4,QJF,QJF1,QM,QSW4,QT,QTP,QTP2,QVL,QX,QXB2,QXC,QXC9,QXE,QXE2,QXE4,QXE6,QXE8,QXF,QXF2,QXH4,QXQ,QXS2,QXU,QX2,QX26,QX4,QX7,RG,RH,RHA2,RHQ4,RH2,RH26,RMG2,RX,RXU,RX2,RX4,SD,SDB1,SDB2,SDN,SD4,SH,SHQ4,SJ,SJG,SMC4,SMG1,SMG2,SM11,SM12,SM14,SM21,SM22,SM24,SWG4,SX,SXE4,SXU,SX4,SX7,TX,TXE,TXU,TXU1,TX2,TX4,UX,VA2,VEE1,VEN1,VES1,VGG2,VMG1,VNG4,VSD,VSD7,VX,VXU,VXU1,VX2,VX4
	90043-ZB2-003	BOLT, STUD, 6X94	-	2	2		
			2	-	-	-----	VAA,VAA1,VEN,VEN4,VES,VMT,VSD1,VSD2,VS17
11	90047-ZE1-000	BOLT, STUD, 8X32	2	2	2		
12	94301-10160	DOWEL PIN, 10X16	2	2	2		
13	95002-80000	CLIP, TUBE (C12)	2	-	-	-----	HXQ,QH4,QTP2,QXC,QXC9,QXH4,QXQ
14	95723-08060-00	BOLT, FLANGE, 8X60	4	4	4		
15	98079-55846	PLUG, SPARK (BPR5E5)(NGK) ...	(1)	-	-	-----	BL,HX,HXQ,HXU,HX2,HX26,HX4,LH,LHB2,LHP1,LHQ4,LVL,LX,LX2,LX4,NX,QA,QAB2,QA2,QG,QG2,QH,QHP1,QHQ4,QH26,QTP,QVL,QX,QXB2,QXE8,QXF,QXF2,QXQ,QXU,QX2,QX26,QX4,QX7,RG,RH,RHA2,RHQ4,RH2,RH26,RMG2,RX,RXU,RX2,RX4,SH,SHQ4,SM12,SM22,TX,TXE,TXU,TXU1,TX2,TX4,UX,VNG4,VSD,VSD1,VSD2,VSD7,VS17,VX,VXU,VXU1,VX2,VX4
	98079-55855	PLUG, SPARK (W16EPR-U)(DENSO)	-	(1)	-		
			(1)	-	-	-----	BL,HX,HXQ,HXU,HX2,HX26,HX4,LH,LHB2,LHP1,LHQ4,LVL,LX,LX2,LX4,NX,QA,QAB2,QA2,QG,QG2,QH,QHP1,QHQ4,QH26,QTP,QVL,QX,QXB2,QXE8,QXF,QXF2,QXQ,QXU,QX2,QX26,QX4,QX7,RG,RH,RHA2,RHQ4,RH2,RH26,RMG2,RX,RXU,RX2,RX4,SH,SHQ4,SM12,SM22,TX,TXE,TXU,TXU1,TX2,TX4,UX,VNG4,VSD,VSD1,VSD2,VSD7,VS17,VX,VXU,VXU1,VX2,VX4
			-	(1)	-		



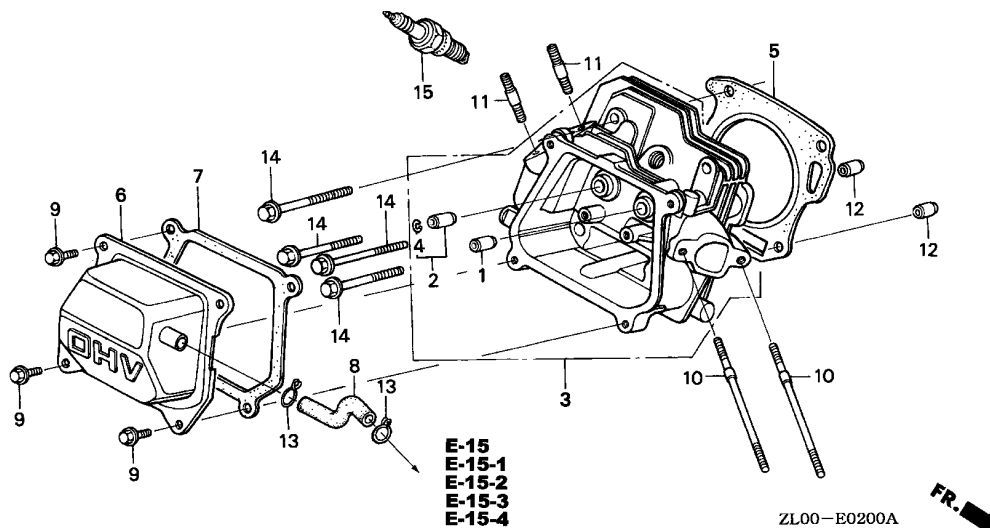

E-15
E-15-1
E-15-2
E-15-3
E-15-4

ZL00-E0200A



Ref. No.	Part No.	Description	Reqd. QTY			Serial No.	Parts catalogue code
			(1)	(2)	(3)		
15)	98079-56841	PLUG, SPARK (BP6ES) (NGK)	1	-	-	-----	BL,LD,LDB1,LDB2,LDN,LD4,LJ,LJC1,LJG,LSJ,LVL,NAX,NAX1,NJ,NJC1,NJG NMB,NTB,NTU,NW,NWA,NWB2,QD,QJF,QJF1,QM,QVL,SD,SDB1,SDB2,SDN,SD4 SJ,SJG,SMG1,SMG2,VEN,VES
			1	-	-	1122110	LHB2,QAB2,VEE1
			1	-	-	1267448	SM11,SM21,VMG1
	98079-56854	PLUG, SPARK (W20EP-U) (DENSO)	1	-	1	-----	BL,LD,LDB1,LDB2,LDN,LD4,LJ,LJC1,LJG,LSJ,LVL,NAX,NAX1,NJ,NJC1,NJG NMB,NTB,NTU,NW,NWA,NWB2,QD,QJF,QJF1,QM,QT,QVL,SD,SDB1,SDB2,SDN SD4,SJ,SJG,SMG1,SMG2,VEN,VES
			1	-	-	1122110	LHB2,QAB2,VEE1
			1	-	-	1267448	SM11,SM21,VMG1
	98079-56846	PLUG, SPARK (BPR6ES) (NGK)	1	-	-	-----	HX,HXQ,HXU,HX2,HX26,HX4,LH,LHP1,LHQ4,LX,LX2,LX4,NDF1,NDJ,NX,PMX PX,PXU,PX2,QA,QA2,QG,QG2,QH,QHP1,QHQ4,QH26,QH4,QSW4,QTP,QTP2,QX QXB2,QXC,QXC9,QXE,QXE2,QXE4,QXE6,QXE8,QXF,QXF2,QXH4,QXQ,QXS2,QXU QX2,QX26,QX4,QX7,RG,RH,RHA2,RHQ4,RH2,RH26,RMG2,RX,RXU,RX2,RX4,SH SHQ4,SMC4,SM12,SM14,SM22,SM24,SWG4,SX,SXE4,SXU,SX4,SX7,TX,TXE,TXU TXU1,TX2,TX4,UX,VAA,VAA1,VA2,VEN1,VEN4,VES1,VGG2,VMT,VNG4,VSD VSD1,VSD2,VSD7,VS17,VX,VXU,VXU1,VX2,VX4
			1	-	-	1122111	LHB2,QAB2,VEE1
			1	-	-	1267449	SM11,SM21,VMG1
			-	1	-	-----	

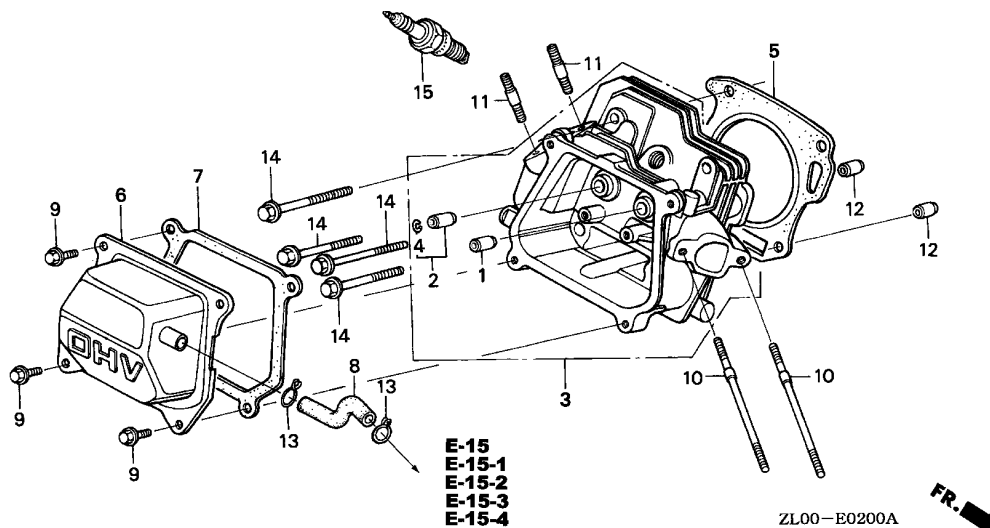

Ref. No.	Part No.	Description	Reqd. QTY			Serial No.	Parts catalogue code
			(1)	GX200 (2)	(3)		
15)	98079-56855	PLUG, SPARK (W20EPR-U) (DENSO)	1	-	-	-----	HX, HXQ, HXU, HX2, HX26, HX4, LH, LHP1, LHQ4, LX, LX2, LX4, NDF1, NDJ, NX, PMX, PX, PXU, PX2, QA, QA2, QG, QG2, QH, QHP1, QHQ4, QH26, QH4, QSW4, QTP, QTP2, QX, QXB2, QXC, QXC9, QXE, QXE2, QXE4, QXE6, QXE8, QXF, QXF2, QXH4, QXQ, QXS2, QXU, QX2, QX26, QX4, QX7, RG, RH, RHA2, RHQ4, RH2, RH26, RMG2, RX, RXU, RX2, RX4, SH, SHQ4, SMC4, SM12, SM14, SM22, SM24, SWG4, SX, SXE4, SXU, SX4, SX7, TX, TXE, TXU, TXU1, TX2, TX4, UX, VAA, VAA1, VA2, VEN1, VEN4, VES1, VGG2, VMT, VNG4, VSD, VSD1, VSD2, VSD7, VS17, VX, VXU, VXU1, VX2, VX4
			1	-	-	1122111	----- LHB2, QAB2, VEE1
			1	-	-	1267449	----- SM11, SM21, VMG1
			-	1	-		



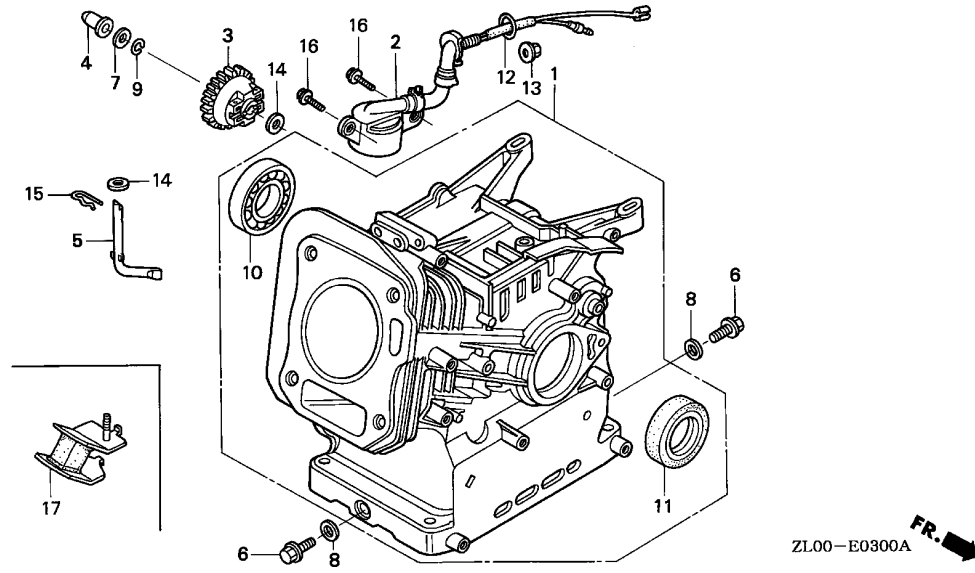

Ref. No.	L.O.N.	(Relative ref. Number) Description	F.R.T.
1	1101A0	BARREL, CYLINDER	2.0
2		(12)	
	6151E8	SWITCH, OIL LEVEL	0.5
	1161C4	GOVERNOR ASSEMBLY	0.9
	1161B6	SLIDER, GOVERNOR	0.4
	1161B4	SHAFT, GOVERNOR ARM	0.9
	1101D5	WASHER, DRAIN PLUG	0.1
	1101A4	BEARING, CRANKSHAFT :FRONT ...	1.9
	1101E4	OIL SEAL, CRANKSHAFT :FRONT ..	1.8

Ref. No.	Part No.	Description	Reqd. QTY			Serial No.	Parts catalogue code
			(1)	GX200 (2)	(3)		
1	12000-ZL0-010	BARREL ASSY., CYLINDER	1	-	-	LD,LDB1,LDB2,LDN,LD4,NAX,NAX1,NDF1,NWA,NWB2,QA,QA2,QG,QT,RG,SDB1,SDN,SD4	
	12000-ZL0-811	-	-	1	HXQ,HX4,LSJ,LX,PMX,PX2,QSW4,QXC,QXE,QXF,QXF2,QXQ,TXE,TX4,UX,VAA,VAA1,VA2,VNG4,VX4P	
	12000-ZL0-406	1	-	-	1853341 BL,LH,LHB2,LHP1,LHQ4,LJ,LJG,LVL,NDJ,NJ,NJC1,NJG,NMB,NTB,NTU,NW,QAB2,QD,QH,QHP1,QHQ4,QH26,QJF,QJF1,QM,QTP,QVL,QXB2,RH,RHA2,RHQ4,RH2,RH26,RMG2,SD,SDB2,SH,SHQ4,SJ,SJG,SMG2,SM11	
	12000-ZL0-407	1	1	-	1853341 HX,HXU,HX2,HX26,LJC1,LX2,LX4,NX,PX,PXU,QG2,QH4,QTP2,QX,QXC9,QXE2,QXE4,QXE6,QXE8,QXH4,QXS2,QXU,QX2,QX26,QX4,QX7,RX,RXU,RX2,RX4,SMC4,SMG1,SM12,SM14,SM21,SM22,SM24,SWG4,SX,SXE4,SXU,SX4,SX7,TX,TXU,TXU1,TX2,VEE1,VEN,VEN1,VEN4,VES,VES1,VGG2,VMG1,VMT,VSD,VSD1,VSD2,VSD7,VS17,VX,VXP,VXU,VXU1,VX2,VX4	
	12000-ZL0-416	1	-	-	1853342 BL,LH,LHB2,LHP1,LHQ4,LJ,LJG,LVL,NDJ,NJ,NJC1,NJG,NMB,NTB,NTU,NW,QAB2,QD,QH,QHP1,QHQ4,QH26,QJF,QJF1,QM,QTP,QVL,QXB2,RH,RHA2,RHQ4,RH2,RH26,RMG2,SD,SDB2,SH,SHQ4,SJ,SJG,SMG2,SM11	
	12000-ZL0-417	1	1	-	1853342 HX,HXU,HX2,HX26,LJC1,LX2,LX4,NX,PX,PXU,QG2,QH4,QTP2,QX,QXC9,QXE2,QXE4,QXE6,QXE8,QXH4,QXS2,QXU,QX2,QX26,QX4,QX7,RX,RXU,RX2,RX4,SMC4,SMG1,SM12,SM14,SM21,SM22,SM24,SWG4,SX,SXE4,SXU,SX4,SX7,TX,TXU,TXU1,TX2,VEE1,VEN,VEN1,VEN4,VES,VES1,VGG2,VMG1,VMT,VSD,VSD1,VSD2,VSD7,VS17,VX,VXP,VXU,VXU1,VX2,VX4	
2	15510-ZE1-033	SWITCH ASSY., OIL LEVEL	1	-	-	HX,HXQ,HXU,HX2,HX26,HX4,LJC1,LSJ,LX,LX2,LX4,NX,PMX,PX,PXU,PX2,QG2,QH4,QSW4,QTP2,QX,QXC,QXC9,QXE,QXE2,QXE4,QXE6,QXE8,QXF,QXF2,QXH4,QXQ,QXS2,QXU,QX2,QX26,QX4,QX7,RX,RXU,RX2,RX4,SMC4,SMG1,SM12,SM14,SM21,SM22,SM24,SWG4,SX,SXE4,SXU,SX4,SX7,TX,TXE,TXU,TXU1,TX2,TX4,UX,VAA,VAA1,VA2,VEE1,VEN,VEN1,VEN4,VES,VES1,VGG2,VMG1,VMT,VNG4,VSD,VSD1,VSD2,VSD7,VS17,VX,VXU,VXU1,VX2,VX4	
3	16506-ZL0-000	GOVERNOR ASSY.	-	1	-		
			1	1	1		

Ref. No.	Part No.	Description	Reqd. QTY			Serial No.	Parts catalogue code	
			(1)	GX200 (2)	(3)			
4	16531-ZE1-000	SLIDER, GOVERNOR	1	1	1			
5	16541-ZE1-000	SHAFT, GOVERNOR ARM	1	1	1			
6	90131-ZE1-000	BOLT, DRAIN PLUG	2	2	2			
7	90451-ZE1-000	WASHER, THRUST, 6MM	1	1	1			
8	90601-ZE1-000	WASHER, DRAIN PLUG, 10.2MM ..	2	2	2			
9	90602-ZE1-000	CLIP, GOVERNOR HOLDER	1	1	1			
10	91001-ZF1-003	BEARING, RADIAL BALL (6205TMB) (NTN)	1	1	1			
	91001-ZF1-004	BEARING, RADIAL BALL (6205SH) (KOYO)	1	1	1			
11	91202-883-005	OIL SEAL, 25X41X6	1	-	-	-----	HXQ, HX4, LD, LDB1, LDB2, LDN, LD4, LSJ, LX, NAX, NAX1, NDF1, NWA, NWB2, PMX, PX2, QA, QA2, QG, QSW4, QT, QXC, QXE, QXF, QXF2, QXQ, RG, SDB1, SDN, SD4, TXE, TX4, UX, VAA, VAA1, VA2, VNG4	
			1	-	-	1853341	BL, HX, HXU, HX2, HX26, LH, LHB2, LHP1, LHQ4, LJ, LJC1, LJG, LVL, LX2, LX4, NDJ, NJ, NJC1, NJG, NMB, NTB, NTU, NW, NX, PX, PXU, QAB2, QD, QG2, QH, QHP1, QHQ4, QH26, QH4, QJF, QJF1, QM, QTP, QTP2, QVL, QX, QXB2, QXC9, QXE2, QXE4, QXE6, QXE8, QXH4, QXS2, QXU, QX2, QX26, QX4, QX7, RH, RHA2, RHQ4, RH2, RH26, RMG2, RX, RXU, RX2, RX4, SD, SDB2, SH, SHQ4, SJ, SJG, SMC4, SMG1, SMG2, SM11, SM12, SM14, SM21, SM22, SM24, SWG4, SX, SXE4, SXU, SX4, SX7, TX, TXU, TXU1, TX2, VEE1, VEN, VEN1, VEN4, VES, VES1, VGG2, VMG1, VMT, VSD, VSD1, VSD2, VSD7, VS17, VX, VXU, VXU1, VX2, VX4	
	91201-ZOT-801	1	-	-	1853342	-----	BL, HX, HXU, HX2, HX26, LH, LHB2, LHP1, LHQ4, LJ, LJC1, LJG, LVL, LX2, LX4, NDJ, NJ, NJC1, NJG, NMB, NTB, NTU, NW, NX, PX, PXU, QAB2, QD, QG2, QH, QHP1, QHQ4, QH26, QH4, QJF, QJF1, QM, QTP, QTP2, QVL, QX, QXB2, QXC9, QXE2, QXE4, QXE6, QXE8, QXH4, QXS2, QXU, QX2, QX26, QX4, QX7, RH, RHA2, RHQ4, RH2, RH26, RMG2, RX, RXU, RX2, RX4, SD, SDB2, SH, SHQ4, SJ, SJG, SMC4, SMG1, SMG2, SM11, SM12, SM14, SM21, SM22, SM24, SWG4, SX, SXE4, SXU, SX4, SX7, TX, TXU, TXU1, TX2, VEE1, VEN, VEN1, VEN4, VES, VES1, VGG2, VMG1, VMT, VSD, VSD1, VSD2, VSD7, VS17, VX, VXU, VXU1, VX2, VX4
12	91353-671-004	O-RING, 14MM(NOK)	1	-	-	-----	HX, HXQ, HXU, HX2, HX26, HX4, LJC1, LSJ, LX, LX2, LX4, NX, PMX, PX, PXU, PX2, QG2, QH4, QSW4, QTP2, QX, QXC, QXC9, QXE, QXE2, QXE4, QXE6, QXE8, QXF, QXF2, QXH4, QXQ, QXS2, QXU, QX2, QX26, QX4, QX7, RX, RXU, RX2, RX4, SMC4, SMG1, SM12, SM14, SM21, SM22, SM24, SWG4, SX, SXE4, SXU, SX4, SX7, TX, TXE, TXU, TXU1, TX2, TX4, UX, VAA, VAA1, VA2, VEE1, VEN, VEN1, VEN4, VES, VES1, VGG2, VMG1, VMT, VNG4, VSD, VSD1, VSD2, VSD7, VS17, VX, VXU, VXU1, VX2, VX4	
13	94050-10000	NUT, FLANGE, 10MM	1	-	-	-----	HX, HXQ, HXU, HX2, HX26, HX4, LJC1, LSJ, LX, LX2, LX4, NX, PMX, PX, PXU, PX2, QG2, QH4, QSW4, QTP2, QX, QXC, QXC9, QXE, QXE2, QXE4, QXE6, QXE8, QXF, QXF2, QXH4, QXQ, QXS2, QXU, QX2, QX26, QX4, QX7, RX, RXU, RX2, RX4, SMC4, SMG1, SM12, SM14, SM21, SM22, SM24, SWG4, SX, SXE4, SXU, SX4, SX7, TX, TXE, TXU, TXU1, TX2, TX4, UX, VAA, VAA1, VA2, VEE1, VEN, VEN1, VEN4, VES, VES1, VGG2, VMG1, VMT, VNG4, VSD, VSD1, VSD2, VSD7, VS17, VX, VXU, VXU1, VX2, VX4	
14	94101-06800	WASHER, PLAIN, 6MM	2	2	2			
15	94251-08000	PIN, LOCK, 8MM	1	1	1			
16	95701-06012-00	BOLT, FLANGE, 6X12	2	-	-	-----	HX, HXQ, HXU, HX2, HX26, HX4, LJC1, LSJ, LX, LX2, LX4, NX, PMX, PX, PXU, PX2, QG2, QH4, QSW4, QTP2, QX, QXC, QXC9, QXE, QXE2, QXE4, QXE6, QXE8, QXF, QXF2, QXH4, QXQ, QXS2, QXU, QX2, QX26, QX4, QX7, RX, RXU, RX2, RX4, SMC4, SMG1, SM12, SM14, SM21, SM22, SM24, SWG4, SX, SXE4, SXU, SX4, SX7, TX, TXE, TXU, TXU1, TX2, TX4, UX, VAA, VAA1, VA2, VEE1, VEN, VEN1, VEN4, VES, VES1, VGG2, VMG1, VMT, VNG4, VSD, VSD1, VSD2, VSD7, VS17, VX, VXU, VXU1, VX2, VX4	
17	68326-ZB2-000	RUBBER, FR. BOTTOM	2	-	-	-----	VES, VES1	
	68328-ZB2-000	RUBBER, BOTTOM	2	-	-	-----	NJC1	



E-6

CRANKCASE COVER(1)

E 7

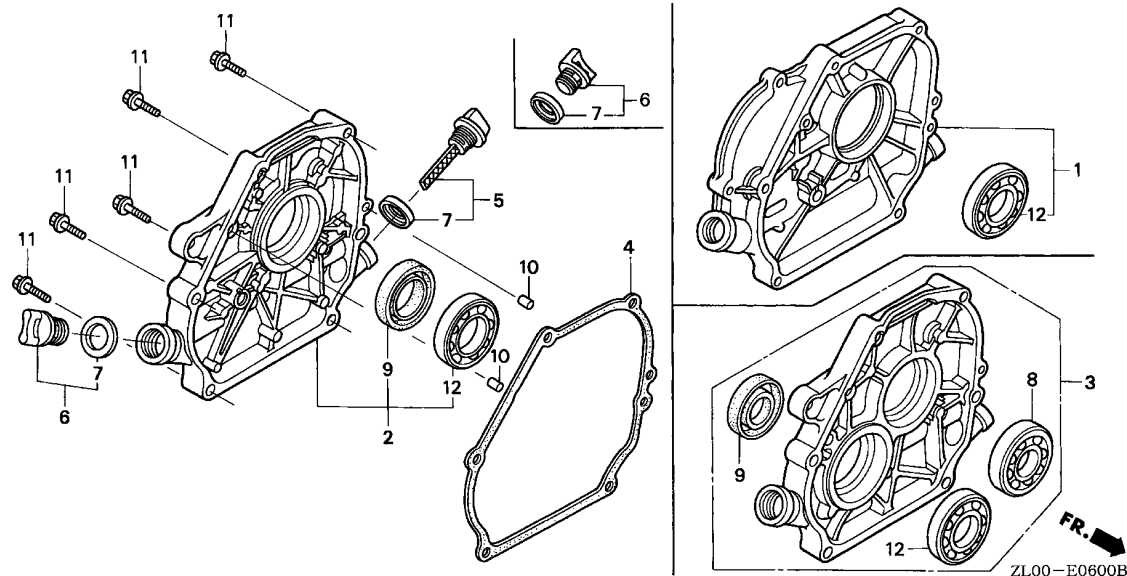

Ref. No.	L.O.N.	(Relative ref. Number) Description	F.R.T.
2		(1,3) COVER, CRANKCASE	0.2
4		1101E9 PACKING, CASE COVER	0.2
8		1101A6 BEARING, CRANKSHAFT :REAR	0.4
9		1101E5 OIL SEAL, CRANKSHAFT :REAR ...	0.3
12		1101A6 BEARING, CRANKSHAFT :REAR	0.4
		2141L0 BEARING, POWER TAKE OFF SHAFT :REAR	0.4

Ref. No.	Part No.	Description	Reqd. QTY			Serial No.	Parts catalogue code
			(1)	GX200 (2)	(3)		
1	11300-ZE1-613	COVER ASSY., CRANKCASE	1	-	-	LD,LDB1,LDB2,LDN,LD4,LH,LHB2,LHP1,LHQ4,LJ,LJC1,LJG,LSJ,LVL,LX,LX2,LX4	
2	11300-ZE1-010	COVER ASSY., CRANKCASE	1	-	1	RG	
	11300-ZE1-633	1	-	-	1853341 RH,RHA2,RHQ4,RH2,RH26,RMG2,RX,RXU,RX2,RX4,SM12 HXQ,HX4,SDB1,SDN,SD4,VAA,VAA1	
	11300-ZE1-641	1	1	-	1854326 BL,HX,HXU,HX2,HX26,QJF,QJF1,SD,SDB2,SH,SHQ4,SJ,SJG,SMC4,SMG1,SMG2 SM11,SM14,SM21,SM22,SM24,SWG4,SX,SXE4,SXU,SX4,SX7,VEE1,VEN,VEN1 VEN4,VES,VES1,VMG1	
	11300-ZE1-020	1	-	-	1854346 PX,PXU,QAB2,QD,QG2,QH,QHP1,QHQ4,QH26,QH4,QM,QTP,QTP2,QVL,QX,QXB2 QXC9,QXE2,QXE4,QXE6,QXE8,QXH4,QXS2,QXU,QX2,QX26,QX4,QX7,TX,TXU TXU1,TX2,VGG2,VSD,VSD1,VSD2,VSD7,VS17,VX,VXU,VXU1,VX2,VX4	
	11300-ZE1-634	1	-	-	1856155 VXP	
	11300-ZE1-642	1	-	-	1853342 RH,RHA2,RHQ4,RH2,RH26,RMG2,RX,RXU,RX2,RX4,SM12 1854327 BL,HX,HXU,HX2,HX26,QJF,QJF1,SD,SDB2,SH,SHQ4,SJ,SJG,SMC4,SMG1,SMG2 SM11,SM14,SM21,SM22,SM24,SWG4,SX,SXE4,SXU,SX4,SX7,VEE1,VEN,VEN1 VEN4,VES,VES1,VMG1	
3	11300-ZL0-690	COVER ASSY., CRANKCASE	1	-	-	1854347 PX,PXU,QAB2,QD,QG2,QH,QHP1,QHQ4,QH26,QH4,QM,QTP,QTP2,QVL,QX,QXB2 QXC9,QXE2,QXE4,QXE6,QXE8,QXH4,QXS2,QXU,QX2,QX26,QX4,QX7,TX,TXU TXU1,TX2,VGG2,VSD,VSD1,VSD2,VSD7,VS17,VX,VXU,VXU1,VX2,VX4	
	11300-ZL0-691	1	-	-	1856156 VXP 1853341 NAX,NAX1,NDF1,NWA,NWB2 1853342 NDJ,NJ,NJC1,NJG,NMB,NTB,NTU,NW,NX	

Ref. No.	Part No.	Description	Reqd. QTY			Serial No.	Parts catalogue code	
			(1)	GX200 (2)	(3)			
4	11381-ZH8-801	PACKING, CASE COVER (NON ASBEST)	1	-	-	-----	1002376 HX, HX4, LD, LD4, LH, LHQ4, LX, LX4, NX, PX, QD, QH, QHQ4, QX, QXC, QXE, QXE4, QX4 RH, RHQ4, RX, RX4, SD, SD4, SH, SHQ4, SX, SX4, TX, TX4, UX, VX, VX4	
			1	-	-	-----	1002566 HXQ, HX2, LX2, PX2, QA, QA2, QXC9, QXE2, QXF, QXF2, QXQ, QXS2, QX2, RH2, TX2 VA2, VX2	
			1	-	-	-----	1003882 LJ, LJG, NJ, SJ, SJG	
	11381-ZL0-000	PACKING, CASE COVER	1	-	-	-----	BL, HXU, HX26, LDB1, LDB2, LDN, LHB2, LHP1, LJC1, LSJ, LVL, NAX, NAX1, NDF1 NDJ, NJC1, NJG, NMB, NTB, NTU, NW, NWA, NWB2, PMX, PXU, QAB2, QG, QG2, QHP1 QH26, QH4, QJF, QJF1, QM, QSW4, QT, QTP, QTP2, QVL, QXB2, QXE6, QXE8, QXH4, QXU QX26, QX7, RG, RHA2, RH26, RMG2, RXU, RX2, SDB1, SDB2, SDN, SMC4, SMG1, SMG2 SM11, SM12, SM14, SM21, SM22, SM24, SWG4, SXE4, SXU, SX7, TXE, TXU, TXU1, VAA VAA1, VEE1, VEN, VEN1, VEN4, VES, VES1, VGG2, VMG1, VNG4, VSD, VSD1, VSD2 VSD7, VS17, VXU, VXU1	
			1	-	-	1002377	-----	HX, HX4, LD, LD4, LH, LHQ4, LX, LX4, NX, PX, QD, QH, QHQ4, QX, QXC, QXE, QXE4, QX4 RH, RHQ4, RX, RX4, SD, SD4, SH, SHQ4, SX, SX4, TX, TX4, UX, VX, VX4
			1	-	-	1002567	-----	HXQ, HX2, LX2, PX2, QA, QA2, QXC9, QXE2, QXF, QXF2, QXQ, QXS2, QX2, RH2, TX2 VA2, VX2
			1	-	-	1003883	-----	LJ, LJG, NJ, SJ, SJG
			-	1	1			
5	15600-ZE1-003	CAP ASSY., OIL FILLER (GRAY)	1	-	-	-----	BL, HX, HXQ, HXU, HX2, HX26, HX4, LD, LDB1, LDB2, LD4, LH, LHB2, LHP1, LHQ4, LJ LJC1, LJG, LSJ, LVL, LX, LX2, LX4, NAX, NAX1, NDF1, NDJ, NJ, NJC1, NJG, NMB, NTB NTU, NW, NWA, NWB2, NX, PMX, PX, PXU, PX2, QA, QAB2, QA2, QD, QG, QG2, QH, QHP1 QH4, QH26, QH4, QJF, QJF1, QM, QSW4, QT, QTP, QTP2, QVL, QX, QXB2, QXC, QXC9, QXE QXE2, QXE4, QXE6, QXE8, QXF, QXF2, QXH4, QXQ, QXS2, QXU, QX2, QX26, QX4, QX7 RG, RH, RHA2, RHQ4, RH2, RH26, RMG2, RX, RXU, RX2, RX4, SD, SDB1, SDB2, SD4, SH SHQ4, SJ, SJG, SMC4, SM11, SM12, SM14, SM21, SM22, SM24, SWG4, SX, SXE4, SXU SX4, SX7, TX, TXE, TXU, TXU1, TX2, TX4, UX, VAA, VAA1, VA2, VEE1, VEN, VEN1 VEN4, VES, VES1, VGG2, VMG1, VNG4, VSD, VSD1, VSD2, VSD7, VS17, VX, VXU, VXU1 VX2, VX4	
			-	1	1			
	15600-ZF0-003	CAP ASSY., OIL FILLER	1	-	-	-----	LDN, QM, QT, SDN	
6	15600-ZG4-003	CAP ASSY., OIL FILLER	1	-	-	-----	BL, HX, HXQ, HXU, HX2, HX26, HX4, LD, LDB1, LDB2, LDN, LD4, LH, LHB2, LHP1, LHQ4 LJ, LJC1, LJG, LSJ, LVL, LX, LX2, LX4, NAX, NAX1, NDF1, NDJ, NJ, NJC1, NJG, NMB NTB, NTU, NW, NWA, NWB2, NX, PMX, PX, PXU, PX2, QA, QAB2, QA2, QD, QG, QG2, QH QHP1, QHQ4, QH26, QH4, QJF, QJF1, QM, QSW4, QT, QTP, QTP2, QVL, QX, QXB2, QXC QXC9, QXE, QXE2, QXE4, QXE6, QXE8, QXF, QXF2, QXH4, QXQ, QXS2, QXU, QX2, QX26 QX4, QX7, RG, RH, RHA2, RHQ4, RH2, RH26, RMG2, RX, RXU, RX2, RX4, SD, SDB1, SDB2 SDN, SD4, SH, SHQ4, SJ, SJG, SMC4, SM11, SM12, SM14, SM21, SM22, SM24, SWG4, SX SXE4, SXU, SX4, SX7, TX, TXE, TXU, TXU1, TX2, TX4, UX, VAA, VAA1, VA2, VEE1, VEN VEN1, VEN4, VES, VES1, VGG2, VMG1, VNG4, VSD, VSD1, VSD2, VSD7, VS17, VX, VXU VXU1, VX2, VX4	
			2	-	-	-----	SMG1, SMG2	
			-	1	1			
7	15625-ZE1-003	PACKING, OIL FILLER CAP	2	-	-	-----	BL, HX, HXQ, HXU, HX2, HX26, HX4, LD, LDB1, LDB2, LDN, LD4, LH, LHB2, LHP1, LHQ4 LJ, LJC1, LJG, LSJ, LVL, LX, LX2, LX4, NAX, NAX1, NDF1, NDJ, NJ, NJC1, NJG, NMB NTB, NTU, NW, NWA, NWB2, NX, PMX, PX, PXU, PX2, QA, QAB2, QA2, QD, QG, QG2, QH QHP1, QHQ4, QH26, QH4, QJF, QJF1, QM, QSW4, QT, QTP, QTP2, QVL, QX, QXB2, QXC QXC9, QXE, QXE2, QXE4, QXE6, QXE8, QXF, QXF2, QXH4, QXQ, QXS2, QXU, QX2, QX26 QX4, QX7, RG, RH, RHA2, RHQ4, RH2, RH26, RMG2, RX, RXU, RX2, RX4, SD, SDB1, SDB2 SDN, SD4, SH, SHQ4, SJ, SJG, SMC4, SMG1, SMG2, SM11, SM12, SM14, SM21, SM22 SM24, SWG4, SX, SXE4, SXU, SX4, SX7, TX, TXE, TXU, TXU1, TX2, TX4, UX, VAA, VAA1, VA2, VEE1, VEN VEN1, VEN4, VES, VES1, VGG2, VMG1, VNG4, VSD, VSD1, VSD2, VSD7, VS17, VX, VXU VXU1, VX2, VX4	
			-	2	2			
8	91001-GF6-004	BEARING, RADIAL BALL, 6304 ..	1	-	-	-----	NAX, NAX1, NDF1, NDJ, NJ, NJC1, NJG, NMB, NTB, NTU, NW, NWA, NWB2, NX	

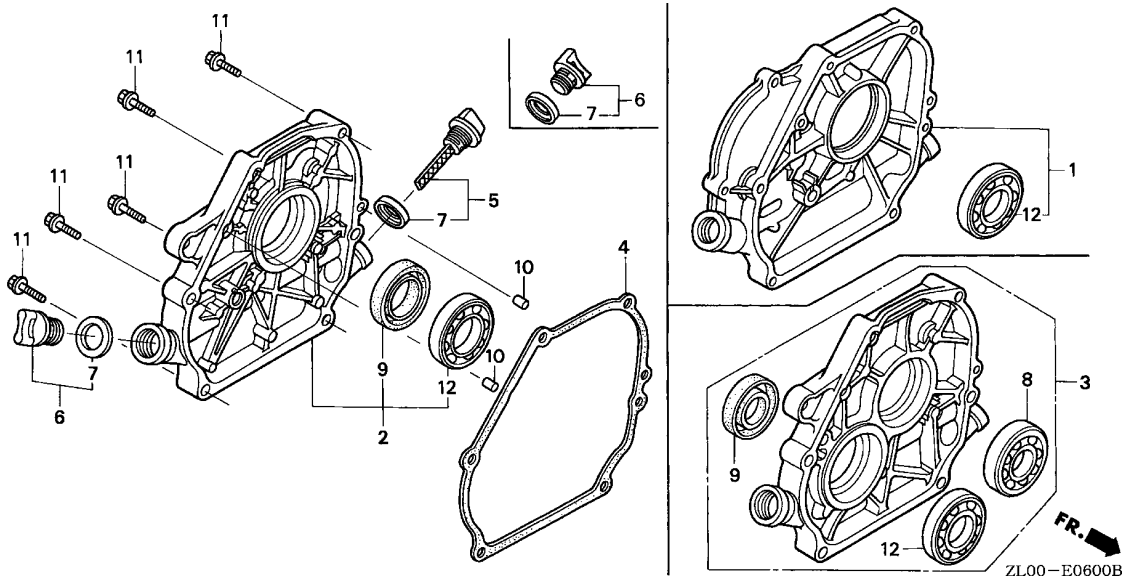

Ref. No.	Part No.	Description	Reqd. QTY			Serial No.	Parts catalogue code
			(1)	GX200 (2)	(3)		
9	91202-883-005	OIL SEAL, 25X41X6	1	-	-	-----	HXQ, HX4, NAX, NAX1, NDF1, NWA, NWB2, PMX, PX2, QA, QA2, QG, QSW4, QT, QXC, QXE QXF, QXF2, QXQ, RG, SDB1, SDN, SD4, TXE, TX4, UX, VAA, VAA1, VA2, VNG4
			1	-	-	1853341	NDJ, NJ, NJC1, NJG, NMB, NTB, NTU, NW, NX, RH, RHA2, RHQ4, RH2, RH26, RMG2, RX RXU, RX2, RX4, SM12
			1	-	-	1854326	BL, HX, HXU, HX2, HX26, QJF, QJF1, SD, SDB2, SH, SHQ4, SJ, SJG, SMC4, SMG1, SMG2 SM11, SM14, SM21, SM22, SM24, SWG4, SX, SXE4, SXU, SX4, SX7, VEE1, VEN, VEN1 VEN4, VES, VES1, VMG1
			1	-	-	1854346	PX, PXU, QAB2, QD, QG2, QH, QHP1, QHQ4, QH26, QH4, QM, QTP, QTP2, QVL, QX, QXB2 QXC9, QXE2, QXE4, QXE6, QXE8, QXH4, QXS2, QXU, QX2, QX26, QX4, QX7, TX, TXU TXU1, TX2, VGG2, VSD, VSD1, VSD2, VSD7, VS17, VX, VXU, VXU1, VX2, VX4
	91201-Z0T-801	-	1	-	-----	
			1	-	-	1853342	NDJ, NJ, NJC1, NJG, NMB, NTB, NTU, NW, NX, RH, RHA2, RHQ4, RH2, RH26, RMG2, RX RXU, RX2, RX4, SM12
			1	-	-	1854327	BL, HX, HXU, HX2, HX26, QJF, QJF1, SD, SDB2, SH, SHQ4, SJ, SJG, SMC4, SMG1, SMG2 SM11, SM14, SM21, SM22, SM24, SWG4, SX, SXE4, SXU, SX4, SX7, VEE1, VEN, VEN1 VEN4, VES, VES1, VMG1
			1	-	-	1854347	PX, PXU, QAB2, QD, QG2, QH, QHP1, QHQ4, QH26, QH4, QM, QTP, QTP2, QVL, QX, QXB2 QXC9, QXE2, QXE4, QXE6, QXE8, QXH4, QXS2, QXU, QX2, QX26, QX4, QX7, TX, TXU TXU1, TX2, VGG2, VSD, VSD1, VSD2, VSD7, VS17, VX, VXU, VXU1, VX2, VX4

Ref. No.	Part No.	Description	Reqd. QTY			Serial No.	Parts catalogue code
			(1)	GX200 (2)	(3)		
10	94301-08140	DOWEL PIN, 8X14	2	-	-	-----	BL, HX, HXQ, HXU, HX2, HX26, HX4, LD, LDB1, LDB2, LDN, LD4, LH, LHB2, LHP1, LHQ4, LJ, LJC1, LJG, LSJ, LVL, LX, LX2, LX4, NAX, NAX1, NDF1, NDJ, NJ, NJC1, NJG, NMB, NTB, NTU, NW, NWA, NWB2, NX, PMX, PX, PXU, PX2, QA, QAB2, QA2, QD, QG, QG2, QH, QHP1, QHQ4, QH26, QH4, QJF, QJF1, QM, QSW4, QT, QTP, QTP2, QVL, QX, QXB2, QXC, QXC9, QXE, QXE2, QXE4, QXE6, QXE8, QXF, QXF2, QXH4, QXQ, QXS2, QXU, QX2, QX26, QX4, QX7, RG, RH, RHA2, RHQ4, RH2, RH26, RMG2, RX, RXU, RX2, RX4, SD, SDB1, SDB2, SDN, SD4, SH, SHQ4, SJ, SJG, SMC4, SMG1, SMG2, SM11, SM12, SM14, SM21, SM22, SM24, SWG4, SX, SXE4, SXU, SX4, SX7, TX, TXE, TXU, TXU1, TX2, TX4, UX, VAA, VAA1, VA2, VEE1, VEN, VEN1, VEN4, VES, VES1, VGG2, VMG1, VNG4, VSD, VSD1, VSD2, VSD7, VS17, VX, VXU, VXU1, VX2, VX4
			-	2	2		
11	95701-08030-00	BOLT, FLANGE, 8X30	6	-	-	-----	LJ, LJG, NJ, SJ, SJG
	95701-08032-00	BOLT, FLANGE, 8X32	6	-	-	-----	BL, HX, HXQ, HXU, HX2, HX26, HX4, LD, LDB1, LDB2, LDN, LD4, LH, LHB2, LHP1, LHQ4, LJ, LJC1, LSJ, LVL, LX, LX2, LX4, NAX, NAX1, NDF1, NDJ, NJC1, NJG, NMB, NTB, NTU, NW, NWA, NWB2, NX, PMX, PX, PXU, PX2, QA, QAB2, QA2, QD, QG, QG2, QH, QHP1, QHQ4, QH26, QH4, QJF, QJF1, QM, QSW4, QT, QTP, QTP2, QVL, QX, QXB2, QXC, QXC9, QXE, QXE2, QXE4, QXE6, QXE8, QXF, QXF2, QXH4, QXQ, QXS2, QXU, QX2, QX26, QX4, QX7, RG, RH, RHA2, RHQ4, RH2, RH26, RMG2, RX, RXU, RX2, RX4, SD, SDB1, SDB2, SDN, SD4, SH, SHQ4, SMC4, SMG1, SMG2, SM11, SM12, SM14, SM21, SM22, SM24, SWG4, SX, SXE4, SXU, SX4, SX7, TX, TXE, TXU, TXU1, TX2, TX4, UX, VAA, VAA1, VA2, VEE1, VEN, VEN1, VEN4, VES, VES1, VGG2, VMG1, VNG4, VSD, VSD1, VSD2, VSD7, VS17, VX, VXU, VXU1, VX2, VX4
12	96100-62050-00	BEARING, RADIAL BALL, 6205 ..	1	-	6	-----	-----
			-	1	1		



E-6-1

CRANKCASE COVER(2)(VMT)

E11

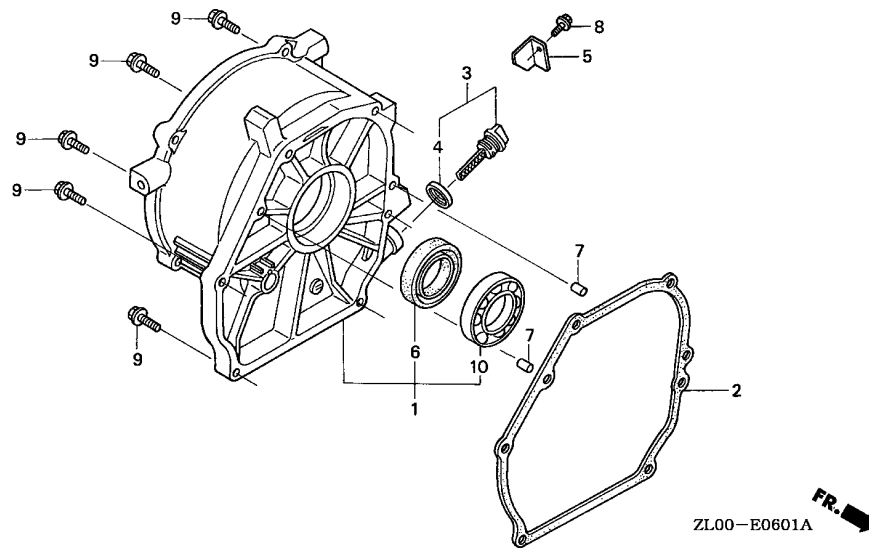

Ref. No.	L.O.N.	(Relative ref. Number) Description	F.R.T.
1	1101F1	COVER, CRANKCASE	0.2
2	1101E9	PACKING, CASE COVER	0.2
6	1101E5	OIL SEAL, CRANKSHAFT :REAR ...	0.3
10	1101A6	BEARING, CRANKSHAFT :REAR	0.4

Ref. No.	Part No.	Description	Reqd. QTY			Serial No.	Parts catalogue code
			(1)	GX200 (2)	(3)		
1	11300-ZH8-F00	COVER ASSY., CRANKCASE	1	-	-	1853341	VMT
	11300-ZH8-F01	1	-	-	1853342	VMT
2	11381-ZL0-000	PACKING, CASE COVER	1	-	-	-----	VMT
3	15600-ZE1-003	CAP ASSY., OIL FILLER (GRAY)	1	-	-	-----	VMT
4	15625-ZE1-003	PACKING, OIL FILLER CAP	1	-	-	-----	VMT
5	50339-ZR4-T60	PLATE, GUARD	1	-	-	-----	VMT
6	91202-883-005	OIL SEAL, 25X41X6	1	-	-	1853341	VMT
	91201-Z0T-801	1	-	-	1853342	VMT
7	94301-08140	DOWEL PIN, 8X14	2	-	-	-----	VMT
8	95701-06012-00	BOLT, FLANGE, 6X12	1	-	-	-----	VMT
9	95701-08032-00	BOLT, FLANGE, 8X32	6	-	-	-----	VMT
10	96100-62050-00	BEARING, RADIAL BALL, 6205 ..	1	-	-	-----	VMT

2

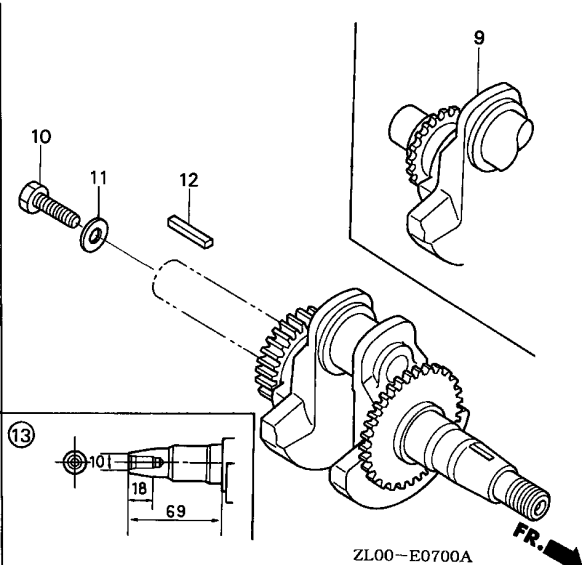
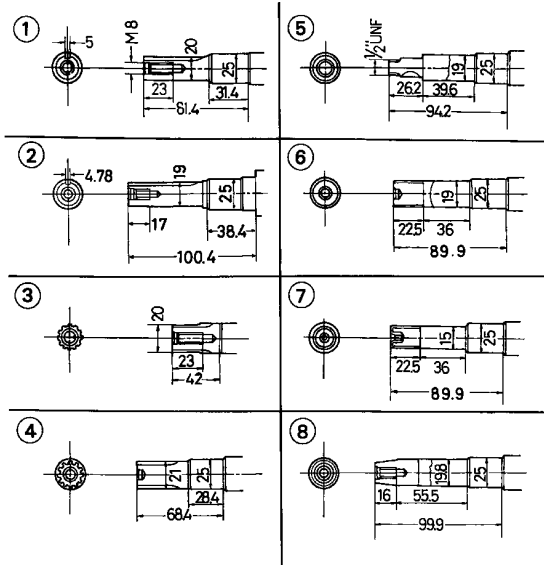

Ref. No.	L.O.N.	(Relative ref. Number) Description	F.R.T.
1	1101F0	(2,3,4,5,6,7,8,9,13) CRANKSHAFT	1.1

Ref. No.	Part No.	Description	Reqd. QTY			Serial No.	Parts catalogue code
			(1)	(2)	(3)		
1	13310-ZL0-000	CRANKSHAFT COMP.	1	-	-	RG, SDB1, SDN, SD4	
	13310-ZL0-880	1	-	-	SX7	
	13310-ZL0-010	1	-	-	RH, RHA2, RHQ4, RH2, RH26, RMG2, RX, RXU, RX2, RX4, SD, SDB2, SH, SHQ4, SJ, SJG, SMC4, SMG1, SMG2, SM11, SM12, SM14, SM21, SM22, SM24, SWG4, SX, SXE4, SXU, SX4	
2	13310-ZL0-600	CRANKSHAFT COMP.	1	-	-	QA, QA2, QG, QSW4, QT, QXC, QXE, QXF, QXF2, QXQ	
			1	-	-	1844979 QAB2, QD, QG2, QH, QHP1, QHQ4, QH26, QH4, QJF, QJF1, QM, QTP, QTP2, QVL, QX, QXB2, QXC9, QXE2, QXE4, QXE6, QXE8, QXH4, QXS2, QXU, QX2, QX26, QX4	
	13310-ZL0-890	1	-	-	QX7	
	13310-ZL0-601	1	-	-	1844980 QAB2, QD, QG2, QH, QHP1, QHQ4, QH26, QH4, QJF, QJF1, QM, QTP, QTP2, QVL, QX, QXB2, QXC9, QXE2, QXE4, QXE6, QXE8, QXH4, QXS2, QXU, QX2, QX26, QX4	
3	13310-ZL0-610	CRANKSHAFT COMP.	1	-	-	LD, LDB1, LDB2, LDN, LD4, LSJ, LX	
			1	-	-	1845962 LH, LHB2, LHP1, LHQ4, LJ, LJC1, LJG, LVL, LX2, LX4	
	13310-ZL0-611	-	-	1		
			1	-	-	1845963 LH, LHB2, LHP1, LHQ4, LJ, LJC1, LJG, LVL, LX2, LX4	
4	13310-ZL0-620	CRANKSHAFT COMP.	1	-	-	HXQ, HX4	
			1	-	-	1846752 HX, HXU, HX2, HX26	
	13310-ZL0-621	1	-	-	1846753 HX, HXU, HX2, HX26	
5	13310-ZL0-640	CRANKSHAFT COMP.	1	-	-	UX	
6	13310-ZL0-650	CRANKSHAFT COMP.	1	-	-	PMX, PX2	
			1	-	-	1843190 PX, PXU	
	13310-ZL0-651	1	-	-	1843191 PX, PXU	
7	13310-ZL0-660	CRANKSHAFT COMP.	1	-	-	TXE, TX4	
			1	-	-	1842810 TX, TXU, TXU1, TX2	
	13310-ZL0-661	1	-	-	1842811 TX, TXU, TXU1, TX2	
8	13310-ZL0-670	CRANKSHAFT COMP.	1	-	-	VAA, VAA1, VA2, VNG4	
			1	-	-	1851599 VGG2, VSD, VSD1, VSD2, VX, VXU, VXU1, VX2, VX4	
	13310-ZL0-870	-	1	-		
			1	-	-	1843200 VSD7, VS17	



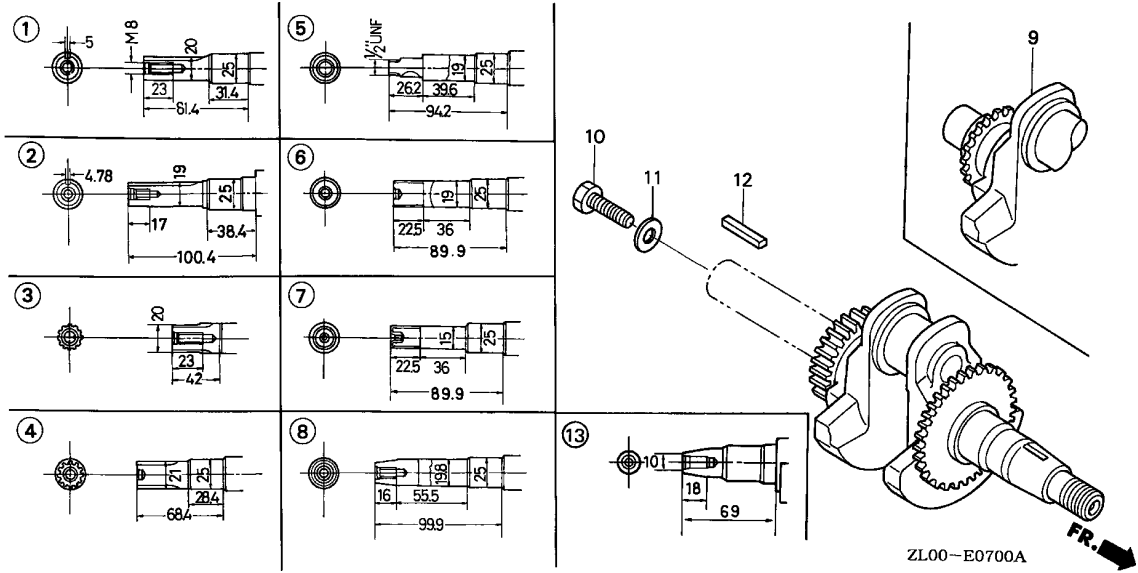

Ref. No.	Part No.	Description	Reqd. QTY			Serial No.	Parts catalogue code
			(1)	GX200 (2)	(3)		
(8)	13310-ZL0-671	CRANKSHAFT COMP.	1	-	-	1851600	VGG2,VSD,VSD1,VSD2,VX,VXU,VXU1,VX2,VX4
	13310-ZL0-871	1	-	-	1843201	VSD7,VS17
9	13310-ZL0-690	CRANKSHAFT COMP.	1	-	-		NAX,NAX1,NDF1,NWA,NWB2
	13310-ZL0-691	1	-	-	1857538	NDJ,NJ,NJC1,NJG,NMB,NTB,NTU,NW,NX
10	90003-ZE1-000	BOLT, HEX., 5/16"	1	-	-		NDJ,NJ,NJC1,NJG,NMB,NTB,NTU,NW,NX
	92101-08025-0A	BOLT, HEX., 8X25	1	-	-	1383993	QH4,QT,QVL,QXH4
			1	-	-		QAB2
			1	-	-	1383993	LVL,NAX,NAX1,NDF1,NDJ,NJ,NJC1,NJG,NMB,NTB,NTU,NW,NWB2,SJ,SJG,SM11
			1	-	-		SM12,SM14,SM21,SM22,SM24
11	90473-842-000	WASHER, 8MM	1	-	-		LHB2
			1	-	-		LVL,NAX,NAX1,NDF1,NDJ,NJ,NJC1,NJG,NMB,NTB,NTU,NW,NWA,NWB2,QH4,QT
			1	-	-		QVL,QXH4,SJ,SJG,SM11,SM12,SM14,SM21,SM22,SM24
12	90741-883-810	KEY, 5X5X33(YELLOW)	1	-	-	1383993	LHB2,QAB2
	90745-ZE1-600	KEY, 4.78X4.78X38	1	-	-		NAX,NAX1,NDF1,NDJ,NJ,NJC1,NJG,NMB,NTB,NTU,NW,NWB2,SJ,SJG,SM11
			1	-	-		SM12,SM14,SM21,SM22,SM24,SWG4,SXE4,SX7
13	13310-ZL0-A00	CRANKSHAFT COMP.	1	-	-	1844018	QA,QAB2,QA2,QD,QG2,QHP1,QH4,QJF,QSW4,QT,QTP2,QVL,QX,QXB2,QXC,QXC9
	13310-ZL0-A01	1	-	-	1844019	QXE,QXE2,QXE4,QXE6,QXF,QXF2,QXH4,QXQ,QXS2,QXU,QX2,QX26,QX4,QX7
			1	-	-		BL,VEE1,VEN,VEN1,VEN4,VES,VES1,VMG1,VMT
			1	-	-		BL,VEE1,VEN,VEN1,VEN4,VES,VES1,VMG1,VMT



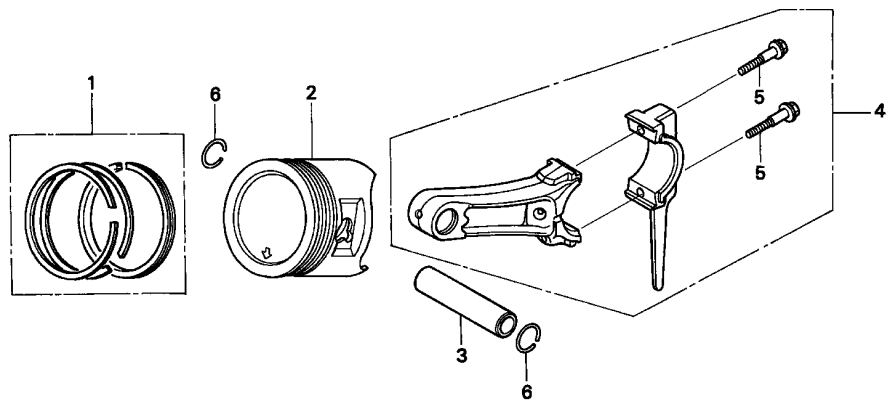

ZL00-E0800A **FR.** →

Ref. No.	L.O.N.	(Relative ref. Number) Description	F.R.T.
4	(1,2,3)		
1101F3		ROD, CONNECTING AND/OR PIN, PISTON	1.0
1101F3A		.Replace 1 piston and/or ring, piston add	0.1

Ref. No.	Part No.	Description	Reqd. QTY			Serial No.	Parts catalogue code
			(1)	(2)	(3)		
1	13010-ZL0-003	RING SET, PISTON (STD.) (TEIKOKU)	1	1	1		
	13010-ZL0-004	RING SET, PISTON (STD.) (NIPPON)	1	1	-	-----	BL, HX, HXU, HX2, HX26, LH, LHB2, LHP1, LHQ4, LJ, LJC1, LJG, LVL, LX2, LX4, NDF1, NDJ, NJ, NJC1, NJG, NMB, NTB, NTU, NW, NX, PMX, PX, PXU, QAB2, QD, QG2, QH, QHP1, QHQ4, QH26, QH4, QJF, QJF1, QM, QTP, QTP2, QVL, QX, QXB2, QXC, QXC9, QXE2, QXE4, QXE6, QXE8, QXH4, QXS2, QXU, QX2, QX26, QX4, QX7, RH, RHA2, RHQ4, RH2, RH26, RMG2, RX, RXU, RX2, RX4, SD, SDB2, SD4, SH, SHQ4, SJ, SJG, SMC4, SMG1, SMG2, SM11, SM12, SM14, SM21, SM22, SM24, SWG4, SX, SXE4, SXU, SX4, SX7, TX, TXU, TXU1, TX2, VEE1, VEN, VEN1, VEN4, VES, VES1, VGG2, VMG1, VMT, VSD, VSD1, VSD2, VSD7, VS17, VX, VXP, VXU, VXU1, VX2, VX4
	13011-ZL0-003	RING SET, PISTON (0.25) (TEIKOKU)	(1)	(1)	(1)		
	13011-ZL0-004	RING SET, PISTON (0.25) (NIPPON)	(1)	(1)	-	-----	BL, HX, HXU, HX2, HX26, LH, LHB2, LHP1, LHQ4, LJ, LJC1, LJG, LVL, LX2, LX4, NDF1, NDJ, NJ, NJC1, NJG, NMB, NTB, NTU, NW, NX, PMX, PX, PXU, QAB2, QD, QG2, QH, QHP1, QHQ4, QH26, QH4, QJF, QJF1, QM, QTP, QTP2, QVL, QX, QXB2, QXC, QXC9, QXE2, QXE4, QXE6, QXE8, QXH4, QXS2, QXU, QX2, QX26, QX4, QX7, RH, RHA2, RHQ4, RH2, RH26, RMG2, RX, RXU, RX2, RX4, SD, SDB2, SD4, SH, SHQ4, SJ, SJG, SMC4, SMG1, SMG2, SM11, SM12, SM14, SM21, SM22, SM24, SWG4, SX, SXE4, SXU, SX4, SX7, TX, TXU, TXU1, TX2, VEE1, VEN, VEN1, VEN4, VES, VES1, VGG2, VMG1, VMT, VSD, VSD1, VSD2, VSD7, VS17, VX, VXP, VXU, VXU1, VX2, VX4
	13012-ZL0-003	RING SET, PISTON (0.50) (TEIKOKU)	(1)	(1)	(1)		



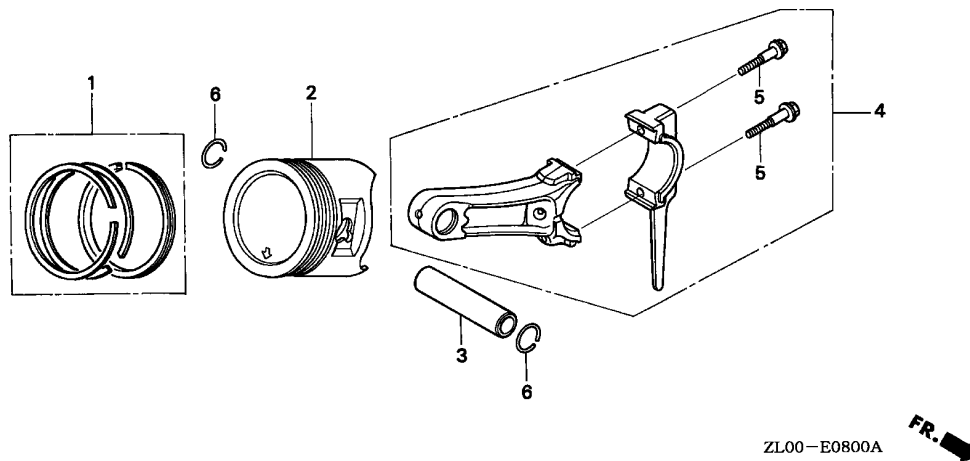

Ref. No.	Part No.	Description	Reqd. QTY			Serial No.	Parts catalogue code
			(1)	(2)	(3)		
(1)	13012-ZL0-004	RING SET, PISTON (0.50) (NIPPON)	(1)	(1)	-	-----	BL,HX,HXU,HX2,HX26,LH,LHB2,LHP1,LHQ4,LJ,LJC1,LJG,LVL,LX2,LX4,NDF1 NDJ,NJ,NJC1,NJG,NMB,NTB,NTU,NW,NX,PMX,PX,PXU,QAB2,QD,QG2,QH,QHP1 QH4,QH26,QH4,QJF,QJF1,QM,QTP,QTP2,QVL,QX,QXB2,QXC,QXC9,QXE2,QXE4 QXE6,QXE8,QXH4,QXS2,QXU,QX2,QX26,QX4,QX7,RH,RHA2,RHQ4,RH2,RH26 RMG2,RX,RXU,RX2,RX4,SD,SDB2,SD4,SH,SHQ4,SJ,SJG,SMC4,SMG1,SMG2 SM11,SM12,SM14,SM21,SM22,SM24,SWG4,SX,SXE4,SXU,SX4,SX7,TX,TXU TXU1,TX2,VEE1,VEN,VEN1,VEN4,VES,VES1,VGG2,VMG1,VMT,VSD,VSD1,VSD2 VSD7,VS17,VX,VXP,VXU,VXU1,VX2,VX4
	13013-ZL0-003	RING SET, PISTON (0.75) (TEIKOKU)	-	-	(1)		
	13013-ZL0-004	RING SET, PISTON (0.75) (NIPPON)	(1)	(1)	(1)	-----	BL,HX,HXU,HX2,HX26,LH,LHB2,LHP1,LHQ4,LJ,LJC1,LJG,LVL,LX2,LX4,NDF1 NDJ,NJ,NJC1,NJG,NMB,NTB,NTU,NW,NX,PMX,PX,PXU,QAB2,QD,QG2,QH,QHP1 QH4,QH26,QH4,QJF,QJF1,QM,QTP,QTP2,QVL,QX,QXB2,QXC,QXC9,QXE2,QXE4 QXE6,QXE8,QXH4,QXS2,QXU,QX2,QX26,QX4,QX7,RH,RHA2,RHQ4,RH2,RH26 RMG2,RX,RXU,RX2,RX4,SD,SDB2,SD4,SH,SHQ4,SJ,SJG,SMC4,SMG1,SMG2 SM11,SM12,SM14,SM21,SM22,SM24,SWG4,SX,SXE4,SXU,SX4,SX7,TX,TXU TXU1,TX2,VEE1,VEN,VEN1,VEN4,VES,VES1,VGG2,VMG1,VMT,VSD,VSD1,VSD2 VSD7,VS17,VX,VXP,VXU,VXU1,VX2,VX4
			-	-	(1)		

Ref. No.	Part No.	Description	Reqd. QTY			Serial No.	Parts catalogue code
			(1)	GX200 (2)	(3)		
2	13101-ZL0-010	PISTON (STD.)	1	1	-	-----	BL, HX, HXU, HX2, HX26, LH, LHB2, LHP1, LHQ4, LJ, LJC1, LJG, LVL, LX2, LX4, NDF1, NDJ, NJ, NJC1, NJG, NMB, NTB, NTU, NW, NX, PMX, PX, PXU, QAB2, QD, QG2, QH, QHP1, QHQ4, QH26, QH4, QJF, QJF1, QTP, QTP2, QVL, QX, QXB2, QXC, QXC9, QXE2, QXE4, QXE6, QXE8, QXH4, QXS2, QXU, QX2, QX26, QX4, QX7, RH, RHA2, RHQ4, RH2, RH26, RMG2, RX, RXU, RX2, RX4, SD, SDB2, SD4, SH, SHQ4, SJ, SJG, SMC4, SMG1, SMG2, SM11, SM12, SM14, SM21, SM22, SM24, SWG4, SX, SXE4, SXU, SX4, SX7, TX, TXU, TXU1, TX2, VEE1, VEN, VEN1, VEN4, VES, VES1, VGG2, VMG1, VMT, VSD, VSD1, VSD7, VS17, VX, VXP, VXU, VXU1, VX2, VX4
	13102-ZL0-010	PISTON (0.25)	(1)	(1)	-	-----	BL, HX, HXU, HX2, HX26, LH, LHB2, LHP1, LHQ4, LJ, LJC1, LJG, LVL, LX2, LX4, NDF1, NDJ, NJ, NJC1, NJG, NMB, NTB, NTU, NW, NX, PMX, PX, PXU, QAB2, QD, QG2, QH, QHP1, QHQ4, QH26, QH4, QJF, QJF1, QM, QTP, QTP2, QVL, QX, QXB2, QXC, QXC9, QXE2, QXE4, QXE6, QXE8, QXH4, QXS2, QXU, QX2, QX26, QX4, QX7, RH, RHA2, RHQ4, RH2, RH26, RMG2, RX, RXU, RX2, RX4, SD, SDB2, SD4, SH, SHQ4, SJ, SJG, SMC4, SMG1, SMG2, SM11, SM12, SM14, SM21, SM22, SM24, SWG4, SX, SXE4, SXU, SX4, SX7, TX, TXU, TXU1, TX2, VEE1, VEN, VEN1, VEN4, VES, VES1, VGG2, VMG1, VMT, VSD, VSD1, VSD2, VSD7, VS17, VX, VXP, VXU, VXU1, VX2, VX4
	13103-ZL0-010	PISTON (0.50)	(1)	(1)	-	-----	BL, HX, HXU, HX2, HX26, LH, LHB2, LHP1, LHQ4, LJ, LJC1, LJG, LVL, LX2, LX4, NDF1, NDJ, NJ, NJC1, NJG, NMB, NTB, NTU, NW, NX, PMX, PX, PXU, QAB2, QD, QG2, QH, QHP1, QHQ4, QH26, QH4, QJF, QJF1, QM, QTP, QTP2, QVL, QX, QXB2, QXC, QXC9, QXE2, QXE4, QXE6, QXE8, QXH4, QXS2, QXU, QX2, QX26, QX4, QX7, RH, RHA2, RHQ4, RH2, RH26, RMG2, RX, RXU, RX2, RX4, SD, SDB2, SD4, SH, SHQ4, SJ, SJG, SMC4, SMG1, SMG2, SM11, SM12, SM14, SM21, SM22, SM24, SWG4, SX, SXE4, SXU, SX4, SX7, TX, TXU, TXU1, TX2, VEE1, VEN, VEN1, VEN4, VES, VES1, VGG2, VMG1, VMT, VSD, VSD1, VSD2, VSD7, VS17, VX, VXP, VXU, VXU1, VX2, VX4
	13104-ZL0-010	PISTON (0.75)	(1)	(1)	-	-----	BL, HX, HXU, HX2, HX26, LH, LHB2, LHP1, LHQ4, LJ, LJC1, LJG, LVL, LX2, LX4, NDF1, NDJ, NJ, NJC1, NJG, NMB, NTB, NTU, NW, NX, PMX, PX, PXU, QAB2, QD, QG2, QH, QHP1, QHQ4, QH26, QH4, QJF, QJF1, QM, QTP, QTP2, QVL, QX, QXB2, QXC, QXC9, QXE2, QXE4, QXE6, QXE8, QXH4, QXS2, QXU, QX2, QX26, QX4, QX7, RH, RHA2, RHQ4, RH2, RH26, RMG2, RX, RXU, RX2, RX4, SD, SDB2, SD4, SH, SHQ4, SJ, SJG, SMC4, SMG1, SMG2, SM11, SM12, SM14, SM21, SM22, SM24, SWG4, SX, SXE4, SXU, SX4, SX7, TX, TXU, TXU1, TX2, VEE1, VEN, VEN1, VEN4, VES, VES1, VGG2, VMG1, VMT, VSD, VSD1, VSD2, VSD7, VS17, VX, VXP, VXU, VXU1, VX2, VX4
	13101-ZL0-800	PISTON (LOW COMPRESSION)	1	-	-	-----	LDN, QT, SDN
	13102-ZL0-800	PISTON (LOW COMPRESSION) (OSZ, 0.25)	(1)	-	-	-----	LDN, QT, SDN
	13103-ZL0-800	PISTON (LOW COMPRESSION) (OSZ, 0.50)	(1)	-	-	-----	LDN, QT, SDN
	13104-ZL0-800	PISTON (LOW COMPRESSION) (OSZ, 0.75)	(1)	-	-	-----	LDN, QT, SDN
	13101-ZL0-801	PISTON (STD.)	1	-	-	-----	QM
	13102-ZL0-801	PISTON (0.25)	(1)	-	(1)	-----	QM
	13103-ZL0-801	PISTON (0.50)	(1)	-	(1)	-----	QM
	13104-ZL0-801	PISTON (0.75)	(1)	-	(1)	-----	QM
3	13111-ZE1-000	PIN, PISTON	1	1	1		
4	13200-ZE1-010	ROD ASSY., CONNECTING (STD.)	1	1	1		
	132A0-ZE1-000	ROD ASSY., CONNECTING (0.25 UNDER SIZE)	(1)	-	-	-----	HX, HXQ, HXU, HX2, HX26, HX4, LD, LDB1, LDB2, LDN, LD4, LH, LHB2, LHP1, LHQ4, LX, LX2, LX4, NTU, NW, NWA, NWB2, NX, PMX, PX, PXU, PX2, QA, QAB2, QA2, QD, QG, QH, QHP1, QHQ4, QH26, QM, QSW4, QT, QTP, QX, QXC, QXC9, QXE, QXE2, QXE4, QXE6, QXE8, QXF, QXF2, QXQ, QXS2, QXU, QX2, QX26, QX4, RG, RH, RHA2, RHQ4, RH2, RH26, RX, RXU, RX2, RX4, SD, SDB1, SDB2, SDN, SD4, SH, SHQ4, SMC4, SX, SXE4, SXU, SX4, TX, TXE, TXU, TXU1, TX2, TX4, UX, VAA1, VA2, VNG4, VSD, VSD1, VX, VXU, VXU1, VX2, VX4
	5 90001-ZE1-000	BOLT, CONNECTING ROD	2	(1)	(1)		
	6 90551-ZE1-000	CLIP, PISTON PIN, 18MM	2	2	2		



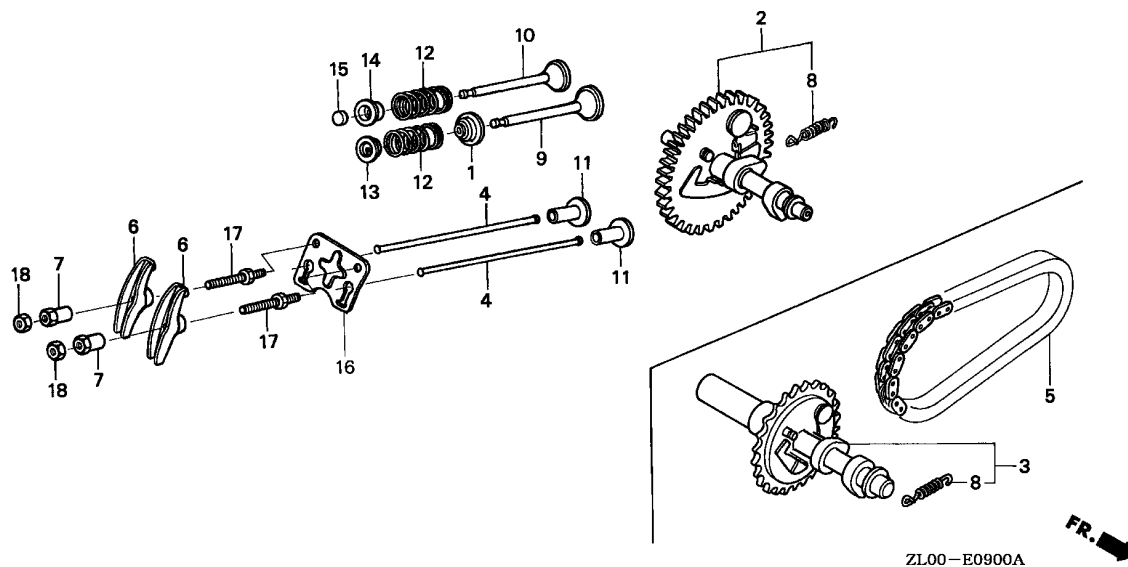

Ref. No.	L.O.N.	(Relative ref. Number) Description	F.R.T.
1	1111K2	SEAL, INTAKE VALVE STEMINCLUDES: Valve clearance adjustment (3)	0.6
2	1111C2	CAMSHAFT	0.4
4	1111L6	ROD, PUSH :INTAKE	0.2
	1111L6A	.For two add	0.1
	1111L7	ROD, PUSH :EXHAUST	0.2
	1111L7A	.For two add	0.1
5	2141C3	CHAIN, POWER TAKE OFF DRIVE ..	0.3
6	1111A2	ARM, ROCKER :INTAKE	0.2
	1111A2A	.With exhaust rocker arm add ..	0.1
	1111A1	ARM, ROCKER :EXHAUST	0.2
	1111A1A	.With intake rocker arm add ..	0.1
+ 9	1111L1	VALVE, INTAKE	0.7

ZL00-E0900A



Ref. No.	Part No.	Description	Reqd. QTY			Serial No.	Parts catalogue code
			(1)	GX200 (2)	(3)		
1	12209-ZL0-003	SEAL, VALVE STEM	1	1	-	-----	HXQ,HX4,LD,LDB1,LDB2,LDN,LD4,LSJ,LX,NAX,NAX1,NWA,NWB2,PX2,QA,QA2,QQ,QSW4,QT,QXE,QXF,QXF2,QXQ,RG,SDB1,SDN,TXE,TX4,UX,VAA,VAA1,VA2,VNG4,VX4P
			1	-	-	1646760	BL,HX,HXU,HX2,HX26,LH,LHB2,LHP1,LHQ4,LJ,LJC1,LJG,LX2,LX4,NDF1,NDJ,NJ,NJC1,NJG,NMB,NTB,NTU,NW,NX,PMX,PX,PXU,QAB2,QD,QG2,QH,QHP1,QHQ4,QH26,QH4,QJF,QJF1,QM,QTP,QTP2,QX,QXC,QXC9,QXE2,QXE4,QXE6,QXS2,QXU,QX2,QX26,QX4,RH,RHA2,RHQ4,RH2,RH26,RMG2,RX,RXU,RX4,SD,SDB2,SD4,SH,SHQ4,SJ,SJG,SMC4,SMG1,SMG2,SM11,SM12,SM14,SM21,SM22,SM24,SX,SXE4,SXU,SX4,TX,TXU,TXU1,TX2,VEE1,VEN,VEN4,VES,VES1,VEG2,VMG1,VMT,VSD,VSD1,VSD2,VX,VXU,VXU1,VX2,VX4
	12209-ZH8-003	-	1	-	1000127	VXP
			1	-	-	1646761	LVL,QVL,QXB2,QXE8,QXH4,QX7,RX2,SWG4,SX7,VEN1,VSD7,VS17
			1	-	-	1000128	BL,HX,HXU,HX2,HX26,LH,LHB2,LHP1,LHQ4,LJ,LJC1,LJG,LX2,LX4,NDF1,NDJ,NJ,NJC1,NJG,NMB,NTB,NTU,NW,NX,PMX,PX,PXU,QAB2,QD,QG2,QH,QHP1,QHQ4,QH26,QH4,QJF,QJF1,QM,QTP,QTP2,QX,QXC,QXC9,QXE2,QXE4,QXE6,QXS2,QXU,QX2,QX26,QX4,RH,RHA2,RHQ4,RH2,RH26,RMG2,RX,RXU,RX4,SD,SDB2,SD4,SH,SHQ4,SJ,SJG,SMC4,SMG1,SMG2,SM11,SM12,SM14,SM21,SM22,SM24,SX,SXE4,SXU,SX4,TX,TXU,TXU1,TX2,VEE1,VEN,VEN4,VES,VES1,VEG2,VMG1,VMT,VSD,VSD1,VSD2,VX,VXU,VXU1,VX2,VX4
			-	1	-	1000128	VXP
			-	-	1		



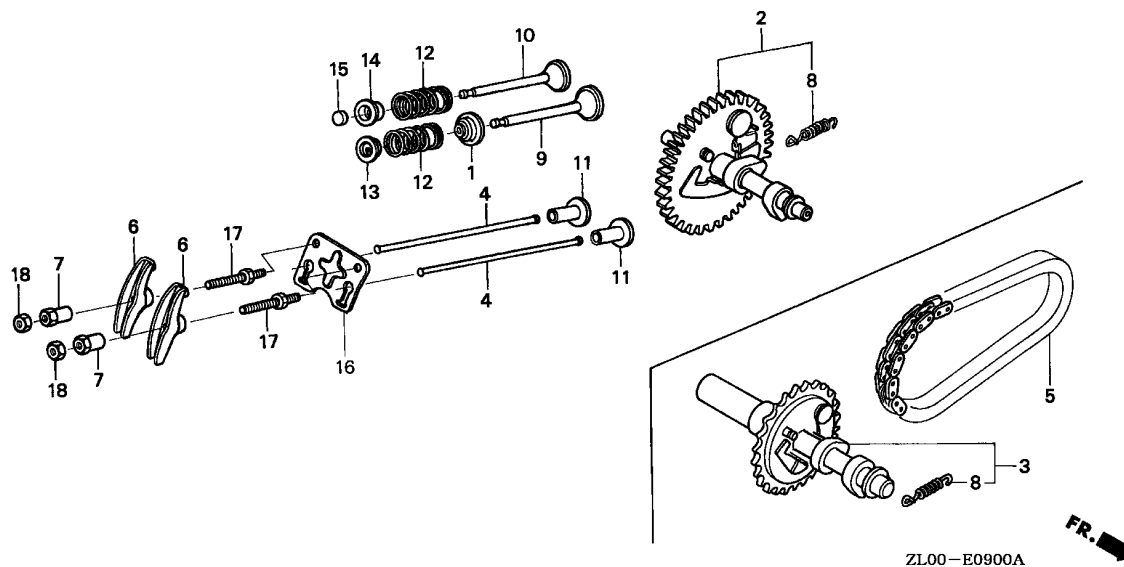

Ref. No.	L.O.N.	(Relative ref. Number) Description	F.R.T.
+ 9		.INCLUDES: Valve clearance adjustment and reface	
	1111L1E	.With intake and exhaust all add	0.1
10	1111L0	VALVE, EXHAUST .INCLUDES: Valve clearance adjustment and reface	0.7
	1111LOE	.With intake and exhaust all add	0.1
11	1111L9	LIFTER, VALVE :INTAKE	0.4
	1111M0	.NOTE: Same time for two units LIFTER, VALVE :EXHAUST	0.4
12	1111P3	SPRING, VALVE :INTAKE .INCLUDES: Valve clearance adjustment	0.6
	1111P3A	.For two add	0.1
	1111P4	SPRING, VALVE :EXHAUST .INCLUDES: Valve clearance adjustment	0.6
	1111P4A	.For two add	0.1
15	1111J7	ROTATOR, VALVE	0.2

Ref. No.	Part No.	Description	Reqd. QTY			Serial No.	Parts catalogue code
			(1)	GX200 (2)	(3)		
2	14100-ZL0-000	CAMSHAFT ASSY.	1	-	-	-----	BL, HX, HXQ, HXU, HX2, HX26, HX4, LD, LDB1, LDB2, LD4, LH, LHB2, LHP1, LHQ4, LJ, LJC1, LJG, LSJ, LVL, LX, LX2, LX4, PMX, PX, PXU, PX2, QA, QAB2, QA2, QD, QG, QG2, QH, QHP1, QHQ4, QH26, QH4, QJF, QJF1, QSW4, QTP, QTP2, QVL, QX, QXB2, QXC, QXC9, QXE, QXE2, QXE4, QXE6, QXE8, QXQ, QXS2, QXU, QX2, QX26, QX4, RG, RH, RHA2, RHQ4, RH2, RH26, RMG2, RX, RXU, RX2, RX4, SD, SDB1, SDB2, SD4, SH, SHQ4, SJ, SJG, SMC4, SMG1, SMG2, SM11, SM12, SM14, SM21, SM22, SM24, SX, SXE4, SXU, SX4, TX, TXE, TXU, TXU1, TX2, TX4, UX, VAA, VAA1, VA2, VEE1, VEN, VEN1, VEN4, VES, VES1, VGG2, VMG1, VMT, VNG4, VSD, VSD1, VSD2, VX, VXU, VXU1, VX2, VX4
	14100-ZL0-800	CAMSHAFT ASSY. (DUTY START) -	-	1	-	-----	LDN, QM, QT, QXF, QXF2, QXH4, SDN, SWG4
	14100-ZL0-870	CAMSHAFT ASSY.	1	-	-	-----	QX7, SX7, VSD7, VS17
3	14100-ZL0-690	CAMSHAFT ASSY.	1	-	-	-----	NAX, NAX1, NDF1, NDJ, NJ, NJC1, NMB, NTB, NTU, NW, NWA, NWB2, NX
			1	-	-	1003701	NJG
4	14410-ZE1-010	ROD, PUSH	2	2	2		
5	14411-ZH7-V91	CHAIN, P.T.O. DRIVE (DID270FH DHA-3)	1	-	-	-----	NAX, NAX1, NDF1, NDJ, NJ, NJC1, NMB, NTB, NTU, NW, NWA, NWB2, NX
			1	-	-	1003701	NJG
6	14431-ZE1-000	ARM, VALVE ROCKER	2	2	2		
7	14451-ZE1-013	PIVOT, ROCKER ARM	2	2	2		



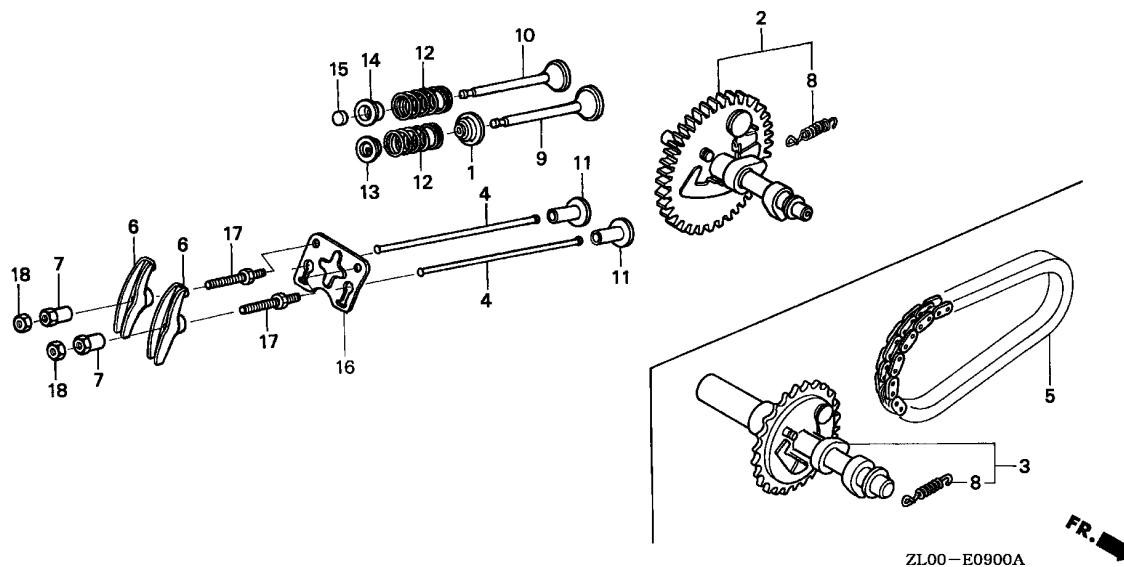

Ref. No.	Part No.	Description	Reqd. QTY			Serial No.	Parts catalogue code
			(1)	(2)	(3)		
8	14568-ZE1-000	SPRING, WEIGHT RETURN	1	-	-	-----	BL, HX, HXQ, HXU, HX2, HX26, HX4, LD, LDB1, LDB2, LDN, LD4, LH, LHB2, LHP1, LHQ4, LJ, LJC1, LJG, LSJ, LVL, LX, LX2, LX4, NAX, NAX1, NDF1, NDJ, NJ, NJC1, NMB, NTB, NTU, NW, NWA, NWB2, NX, PMX, PX, PXU, PX2, QA, QAB2, QA2, QD, QG, QG2, QH, QHP1, QHQ4, QH26, QH4, QJF, QJF1, QM, QSW4, QT, QTP, QTP2, QVL, QX, QXB2, QXC, QXC9, QXE, QXE2, QXE4, QXE6, QXE8, QXF, QXF2, QXH4, QXQ, QXS2, QXU, QX2, QX26, QX4, QX7, RG, RH, RHA2, RHQ4, RH2, RH26, RMG2, RX, RXU, RX2, RX4, SD, SDB1, SDB2, SDN, SD4, SH, SHQ4, SJ, SJG, SMC4, SMG1, SMG2, SM11, SM12, SM14, SM21, SM22, SM24, SWG4, SX, SXE4, SXU, SX4, SX7, TX, TXE, TXU, TXU1, TX2, TX4, UX, VAA, VAA1, VA2, VEE1, VEN, VEN1, VEN4, VES, VES1, VGG2, VMG1, VMT, VNG4, VSD, VSD1, VSD2, VSD7, VS17, VX, VXU, VXU1, VX2, VX4
			1	-	-	-----	1003701 NJG
9	14711-ZF1-000	VALVE, IN.	1	1	1	-----	
10	14721-ZF1-000	VALVE, EX.	1	-	-	-----	HX, HXQ, HXU, HX2, HX26, HX4, LD, LDB1, LDB2, LDN, LD4, LH, LHP1, LHQ4, LJ, LJC1, LJG, LSJ, LX, LX2, LX4, NAX, NAX1, NDF1, NDJ, NJ, NJC1, NJG, NMB, NTB, NTU, NW, NWA, NX, QA, QA2, QD, QG, QG2, QH, QHP1, QHQ4, QH26, QH4, QJF, QJF1, QM, QSW4, QT, QTP, QTP2, QX, QXB2, QXC, QXC9, QXE, QXE2, QXE4, QXE6, QXF, QXF2, QXH4, QXQ, QXS2, QXU, QX2, QX26, QX4, QX7, RG, RH, RHA2, RHQ4, RH2, RH26, RMG2, RX, RXU, RX2, RX4, SD, SDB1, SDB2, SDN, SD4, SH, SHQ4, SJ, SJG, SMC4, SMG1, SMG2, SM11, SM12, SM14, SM21, SM22, SM24, SWG4, SX, SXE4, SXU, SX4, SX7, TX, TXE, TXU, TXU1, TX2, TX4, UX, VAA, VAA1, VA2, VEE1, VEN, VEN1, VEN4, VES, VES1, VGG2, VMG1, VMT, VNG4, VSD, VSD1, VSD2, VSD7, VS17, VX, VXU, VXU1, VX2, VX4
			1	-	-	-----	1383992 BL, LHB2, QAB2
	14721-ZH8-810	VALVE, EX. (STELLITE)	1	-	-	-----	PMX, PX, PXU, PX2, QXE8, TX, TXE, TXU, TXU1, TX2, TX4, UX
	14721-ZK8-W80	VALVE, EX.	1	-	-	-----	LVL, NWB2, QVL
			1	-	-	1383993	----- BL, LHB2, QAB2
	14721-ZE7-000	-	1	-	-----	

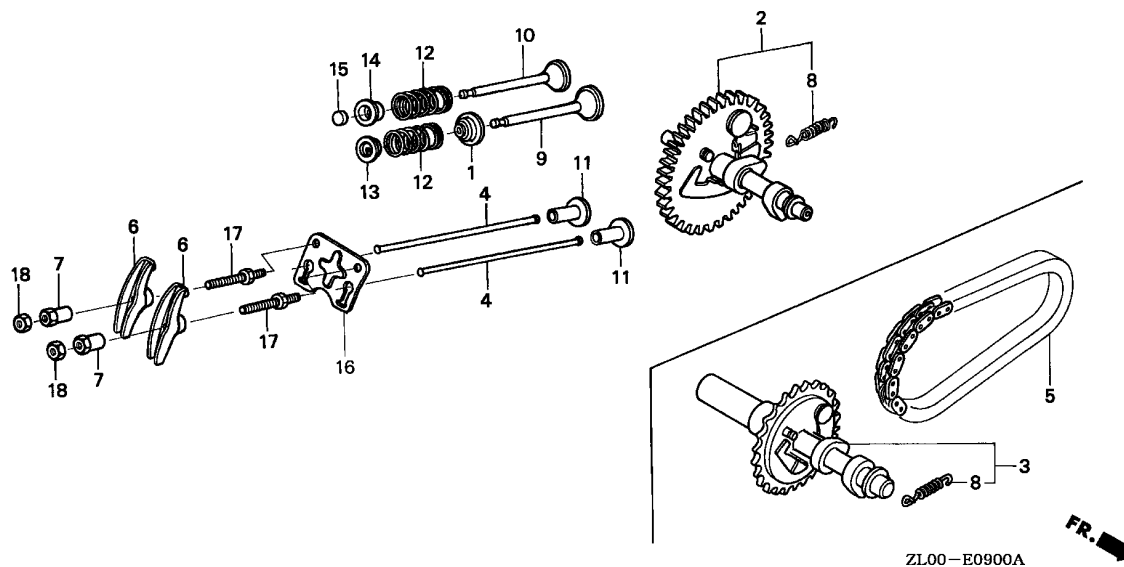

Ref. No.	Part No.	Description	Reqd. QTY			Serial No.	Parts catalogue code
			(1)	(2)	(3)		
11	14731-ZL0-000	LIFTER, VALVE	2	2	2		
12	14751-ZE1-000	SPRING, VALVE	2	-	-	-----	QG, RG
	14751-ZF1-000	2	-	-	-----	BL, HX, HXQ, HXU, HX2, HX26, HX4, LD, LDB1, LDB2, LDN, LD4, LH, LHB2, LHP1, LHQ4, LJ, LJC1, LJG, LSJ, LVL, LX, LX2, LX4, NAX, NAX1, NDF1, NDJ, NJ, NJC1, NJG, NMB, NTB, NTU, NW, NWA, NWB2, NX, PMX, PX, PXU, PX2, QA, QAB2, QA2, QD, QG2, QH, QHP1, QHQ4, QH26, QH4, QJF, QJF1, QM, QSW4, QT, QTP, QTP2, QVL, QX, QXB2, QXC, QXC9, QXE, QXE2, QXE4, QXE6, QXE8, QXF, QXF2, QXH4, QXQ, QXS2, QXU, QX2, QX26, QX4, QX7, RH, RHA2, RHQ4, RH2, RH26, RMG2, RX, RXU, RX2, RX4, SD, SDB1, SDB2, SDN, SD4, SH, SHQ4, SJ, SJG, SMC4, SMG1, SMG2, SM11, SM12, SM14, SM21, SM22, SM24, SWG4, SX, SXE4, SXU, SX4, SX7, TX, TXE, TXU, TXU1, TX2, TX4, UX, VAA, VAA1, VA2, VEE1, VEN, VEN1, VEN4, VES, VES1, VGG2, VMG1, VMT, VNG4, VSD, VSD1, VSD2, VSD7, VS17, VX, VXU, VXU1, VX2, VX4
13	14771-ZE1-000	RETAINER, IN. VALVE SPRING ..	-	2	2		
14	14773-ZE1-000	RETAINER, EX. VALVE SPRING ..	1	-	1		
	14771-ZE1-000	RETAINER, IN. VALVE SPRING ..	-	1	-		
15	14781-ZE1-000	ROTATOR, VALVE	1	-	1		
16	14791-ZE1-010	PLATE, PUSH ROD GUIDE	1	1	1		
17	90012-ZE0-010	BOLT, PIVOT, 8MM	2	2	2		
18	90206-ZE1-000	NUT, PIVOT ADJUSTING	2	2	2		



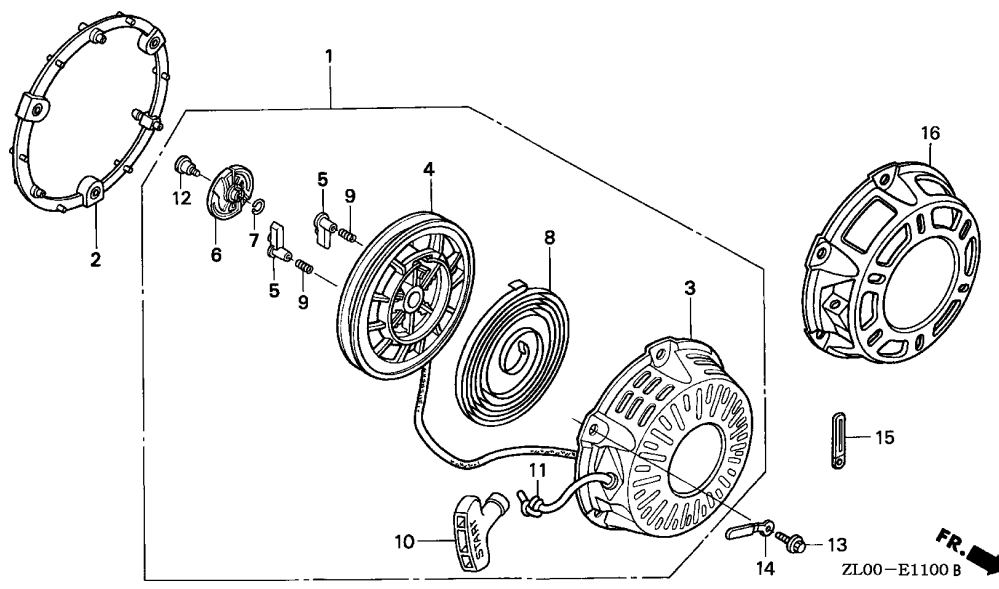

Ref. No.	L.O.N.	(Relative ref. Number) Description	F.R.T.
1	1121B9	STARTER, RECOIL	0.1
2	1121B5	SPACER, RECOIL STARTER MOUNTING	0.1
4	1121B1	REEL, RECOIL STARTER	0.3
5	1121B0	RATCHET, STARTER AND/OR SPRING, RATCHET	0.2
6	1121A4	GUIDE, RATCHET	0.2
8	1121B7	SPRING, RECOIL STARTER RETURN	0.3
11	1121B3	ROPE, RECOIL STARTER	0.3



Ref. No.	Part No.	Description	Reqd. QTY			Serial No.	Parts catalogue code
			(1)	(2)	(3)		
1	28400-ZH8-013ZA	STARTER ASSY., RECOIL *R8*.....BRIGHT RED	1	1	-	-----	HXQ, HX4, LD, LDB1, LDB2, LDN, LD4, LJ, LJG, LSJ, LX, NDF1, NJ, NMB, NWA, NWB2, PMX, PX2, QA, QA2, QG, QSW4, QT, QXC, QXE, QXF, QXF2, QXQ, RG, SDB1, SDN, SD4, SJ, TXE, TX4, UX, VAA, VAA1, VA2, VX4P
			1	-	-	1812939	BL, HX, HXU, HX2, HX26, LH, LHB2, LHP1, LHQ4, LJC1, LX2, LX4, NDJ, NJG, NTB, NW, NX, PX, PXU, QAB2, QD, QG2, QH, QHP1, QHQ4, QH26, QH4, QJF, QM, QTP, QTP2, QX, QXB2, QXC9, QXE2, QXE4, QXE6, QXH4, QXS2, QXU, QX2, QX26, QX4, QX7, RH, RHA2, RHQ4, RH2, RH26, RMG2, RX, RXU, RX2, RX4, SD, SDB2, SH, SHQ4, SJG, SMC4, SMG1, SM11, SM12, SM14, SM21, SM22, SM24, SX, SXE4, SXU, SX4, SX7, TX, TXU, TXU1, TX2, VEE1, VGG2, VMG1, VMT, VSD, VSD1, VSD2, VSD7, VS17, VX, VXU, VXU1, VX2, VX4
	28400-ZH8-013ZB	*NH1*.....BLACK	-	-	1	-----	HX, HXQ, HXU, HX2, HX4, LD, LD4, LHQ4, LJ, LJG, LX, LX2, LX4, NX, PX2, QA, QA2, QD, QHQ4, QM, QT, QXC, QXC9, QXE, QXE2, QXE4, QXF, QXF2, QXQ, QXS2, QX2, RHQ4, RH2, RX, RXU, RX4, SD, SD4, SH, SHQ4, SJ, SJG, SM12, SM14, SM22, TX2, TX4, UX, VA2, VEE1, VEN, VEN1, VEN4, VES, VES1, VMG1, VSD, VSD7, VXU, VXU1, VX2
	28400-ZH8-013ZX	*T38*.....MAT GREEN	1	-	-	-----	VSD
	28400-ZH8-013ZY	*T83*.....GEKO BLUE 2	1	-	-	-----	VNG4, VSD, VX4
	28400-ZH8-D52	1	-	-	-----	NJC1, QJF1
	28400-ZH8-R10ZA	STARTER ASSY., RECOIL (TURFCO) *R8*.....BRIGHT RED	1	-	-	-----	NAX, NAX1
	28400-ZH8-013YA	STARTER ASSY., RECOIL *R280*.....POWER RED	1	1	-	-----	QXE8, VXP
			1	-	-	1812940	BL, HX, HXU, HX2, HX26, LH, LHB2, LHP1, LHQ4, LJC1, LX2, LX4, NDJ, NJG, NTB, NW, NX, PX, PXU, QAB2, QD, QG2, QH, QHP1, QHQ4, QH26, QH4, QJF, QM, QTP, QTP2, QX, QXB2, QXC9, QXE2, QXE4, QXE6, QXH4, QXS2, QXU, QX2, QX26, QX4, QX7, RH, RHA2, RHQ4, RH2, RH26, RMG2, RX, RXU, RX2, RX4, SD, SDB2, SH, SHQ4, SJG, SMC4, SMG1, SM11, SM12, SM14, SM21, SM22, SM24, SX, SXE4, SXU, SX4, SX7, TX, TXU, TXU1, TX2, VEE1, VGG2, VMG1, VMT, VSD, VSD1, VSD2, VSD7, VS17, VX, VXU, VXU1, VX2, VX4

Ref. No.	Part No.	Description	Reqd. QTY			Serial No.	Parts catalogue code
			(1)	GX200 (2)	(3)		
2	28405-ZL0-000ZA	SPACER, RECOIL STARTER MOUNTING					
	NH1BLACK	1	-	-	-----	HX, HXQ, HXU, HX2, HX4, LD, LD4, LHQ4, LJ, LJG, LX, LX2, LX4, NX, PX2, QA, QA2, QD, QHQ4, QJF1, QM, QT, QXC, QXC9, QXE, QXE2, QXE4, QXF, QXF2, QXQ, QXS2, QX2, RHQ4, RH2, RX, RXU, RX4, SD, SD4, SH, SHQ4, SJ, SJG, SM12, SM14, SM22, TX2, TX4, UX, VA2, VEE1, VEN, VEN1, VEN4, VES, VES1, VMG1, VNG4, VSD, VSD7, VXU, VXU1, VX2, VX4
	28405-ZL0-000ZB	*R8*	1	-	-	-----	BL, HXQ, HX4, LD, LDB1, LDB2, LDN, LD4, LJ, LJG, LSJ, LX, NAX, NAX1, NDF1, NJ, NMB, NWA, NWB2, PMX, PX2, QA, QA2, QG, QSW4, QT, QXC, QXE, QXF, QXF2, QXQ, RG, SDB1, SDN, SD4, SJ, TXE, TX4, UX, VAA, VAA1, VA2
			1	-	-	1812939	HX, HXU, HX2, HX26, LH, LHB2, LHP1, LHQ4, LJC1, LX2, LX4, NDJ, NJC1, NJG, NTB, NW, NX, PX, PXU, QAB2, QD, QG2, QH, QHP1, QHQ4, QH26, QH4, QJF, QM, QTP, QTP2, QX, QXB2, QXC9, QXE2, QXE4, QXE6, QXH4, QXS2, QXU, QX2, QX26, QX4, QX7, RH, RHA2, RHQ4, RH2, RH26, RMG2, RX, RXU, RX2, RX4, SD, SDB2, SH, SHQ4, SJG, SMC4, SMG1, SM11, SM12, SM14, SM21, SM22, SM24, SWG4, SX, SXE4, SXU, SX4, SX7, TX, TXU, TXU1, TX2, VEE1, VGG2, VMG1, VMT, VSD, VSD1, VSD2, VSD7, VS17, VX, VXU, VXU1, VX2, VX4
	28405-ZL0-000ZD	*R280*	-	1	1	-----	QXE8
	POWER RED	1	-	-	1812940	HX, HXU, HX2, HX26, LH, LHB2, LHP1, LHQ4, LJC1, LX2, LX4, NDJ, NJC1, NJG, NTB, NW, NX, PX, PXU, QAB2, QD, QG2, QH, QHP1, QHQ4, QH26, QH4, QJF, QM, QTP, QTP2, QX, QXB2, QXC9, QXE2, QXE4, QXE6, QXH4, QXS2, QXU, QX2, QX26, QX4, QX7, RH, RHA2, RHQ4, RH2, RH26, RMG2, RX, RXU, RX2, RX4, SD, SDB2, SH, SHQ4, SJG, SMC4, SMG1, SM11, SM12, SM14, SM21, SM22, SM24, SWG4, SX, SXE4, SXU, SX4, SX7, TX, TXU, TXU1, TX2, VEE1, VGG2, VMG1, VMT, VSD, VSD1, VSD2, VSD7, VS17, VX, VXU, VXU1, VX2, VX4
3	28410-ZH8-003ZA	CASE COMP., RECOIL STARTER					
	R8BRIGHT RED	1	-	-	-----	HXQ, HX4, LD, LDB1, LDB2, LDN, LD4, LJ, LJG, LSJ, LX, NAX, NAX1, NDF1, NJ, NMB, NWA, NWB2, PMX, PX2, QA, QA2, QG, QSW4, QT, QXC, QXE, QXF, QXF2, QXQ, RG, SDB1, SDN, SD4, SJ, TXE, TX4, UX, VAA, VAA1, VA2
			1	-	-	1812939	BL, HX, HXU, HX2, HX26, LH, LHB2, LHP1, LHQ4, LJC1, LX2, LX4, NDJ, NJG, NTB, NW, NX, PX, PXU, QAB2, QD, QG2, QH, QHP1, QHQ4, QH26, QH4, QJF, QM, QTP, QTP2, QX, QXB2, QXC9, QXE2, QXE4, QXE6, QXH4, QXS2, QXU, QX2, QX26, QX4, QX7, RH, RHA2, RHQ4, RH2, RH26, RMG2, RX, RXU, RX2, RX4, SD, SDB2, SH, SHQ4, SJG, SMC4, SMG1, SM11, SM12, SM14, SM21, SM22, SM24, SX, SXE4, SXU, SX4, SX7, TX, TXU, TXU1, TX2, VEE1, VGG2, VMG1, VMT, VSD, VSD1, VSD2, VSD7, VS17, VX, VXU, VXU1, VX2, VX4
	28410-ZH8-003ZB	*NH1*	-	1	1	-----	HX, HXQ, HXU, HX2, HX4, LD, LD4, LHQ4, LJ, LJG, LX, LX2, LX4, NX, PX2, QA, QA2, QD, QHQ4, QM, QT, QXC, QXC9, QXE, QXE2, QXE4, QXF, QXF2, QXQ, QXS2, QX2, RHQ4, RH2, RX, RXU, RX4, SD, SD4, SH, SHQ4, SJ, SJG, SM12, SM14, SM22, TX2, TX4, UX, VA2, VEE1, VEN, VEN1, VEN4, VES, VES1, VMG1, VSD, VSD7, VXU, VXU1, VX2
	28410-ZH8-003ZX	*T38*	1	-	-	-----	VSD
	28410-ZH8-003ZY	*T83*	1	-	-	-----	VNG4, VSD, VX4
	28410-ZH8-D51	1	-	-	-----	NJC1, QJF1
	28410-ZH8-003YA	*R280*	1	-	-	-----	QXE8
	POWER RED	1	-	-	1812940	BL, HX, HXU, HX2, HX26, LH, LHB2, LHP1, LHQ4, LJC1, LX2, LX4, NDJ, NJG, NTB, NW, NX, PX, PXU, QAB2, QD, QG2, QH, QHP1, QHQ4, QH26, QH4, QJF, QM, QTP, QTP2, QX, QXB2, QXC9, QXE2, QXE4, QXE6, QXH4, QXS2, QXU, QX2, QX26, QX4, QX7, RH, RHA2, RHQ4, RH2, RH26, RMG2, RX, RXU, RX2, RX4, SD, SDB2, SH, SHQ4, SJG, SMC4, SMG1, SM11, SM12, SM14, SM21, SM22, SM24, SX, SXE4, SXU, SX4, SX7, TX, TXU, TXU1, TX2, VEE1, VGG2, VMG1, VMT, VSD, VSD1, VSD2, VSD7, VS17, VX, VXU, VXU1, VX2, VX4



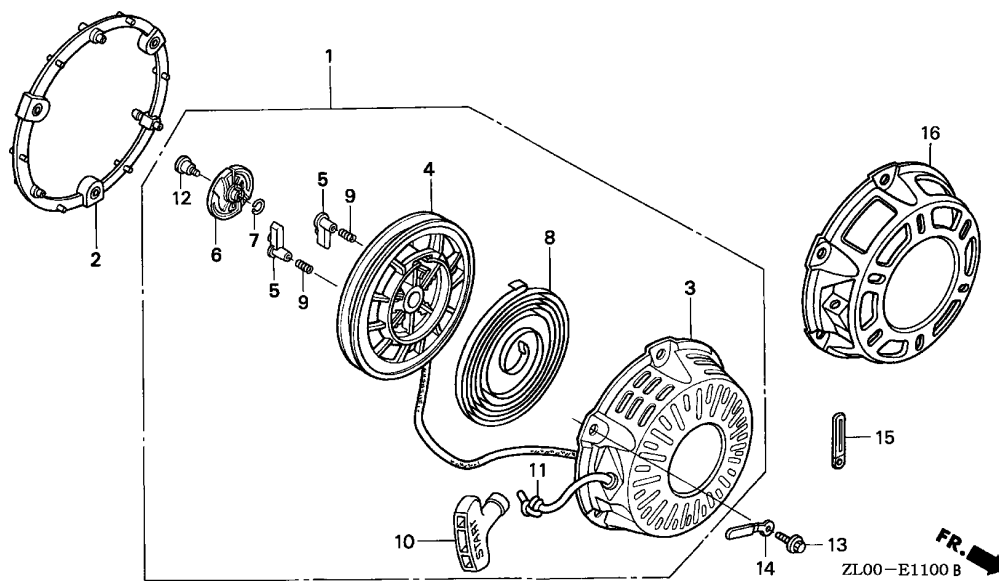

Ref. No.	Part No.	Description	Reqd. QTY			Serial No.	Parts catalogue code
			(1)	(2)	(3)		
4	28420-ZH8-013	REEL, RECOIL STARTER (NATURAL)	1	-	-	-----	BL, HX, HXQ, HXU, HX2, HX26, HX4, LD, LDB1, LDB2, LDN, LD4, LH, LHB2, LHP1, LHQ4, LJ, LJC1, LJG, LSJ, LX, LX2, LX4, NAX, NAX1, NDF1, NDJ, NJ, NJC1, NJG, NMB, NTB, NW, NWA, NWB2, NX, PMX, PX, PXU, PX2, QA, QAB2, QA2, QD, QG, QG2, QH, QHP1, QHQ4, QH26, QH4, QJF, QJF1, QM, QSW4, QT, QTP, QTP2, QX, QXB2, QXC, QXC9, QXE, QXE2, QXE4, QXE6, QXE8, QXF, QXF2, QXH4, QXQ, QXS2, QXU, QX2, QX26, QX4, QX7, RG, RH, RHA2, RHQ4, RH2, RH26, RMG2, RX, RXU, RX2, RX4, SD, SDB1, SDB2, SDN, SD4, SH, SHQ4, SJ, SJG, SMC4, SMG1, SM11, SM12, SM14, SM21, SM22, SM24, SX, SXE4, SXU, SX4, SX7, TX, TXE, TXU, TXU1, TX2, TX4, UX, VAA, VAA1, VA2, VEE1, VEN, VEN1, VEN4, VES, VES1, VGG2, VMG1, VMT, VNG4, VSD, VSD1, VSD2, VSD7, VS17, VX, VXU, VX1, VX2, VX4
5	28422-ZH8-013	RATCHET, STARTER	2	1	1	-----	BL, HX, HXQ, HXU, HX2, HX26, HX4, LD, LDB1, LDB2, LDN, LD4, LH, LHB2, LHP1, LHQ4, LJ, LJC1, LJG, LSJ, LX, LX2, LX4, NAX, NAX1, NDF1, NDJ, NJ, NJC1, NJG, NMB, NTB, NW, NWA, NWB2, NX, PMX, PX, PXU, PX2, QA, QAB2, QA2, QD, QG, QG2, QH, QHP1, QHQ4, QH26, QH4, QJF, QJF1, QM, QSW4, QT, QTP, QTP2, QX, QXB2, QXC, QXC9, QXE, QXE2, QXE4, QXE6, QXE8, QXF, QXF2, QXH4, QXQ, QXS2, QXU, QX2, QX26, QX4, QX7, RG, RH, RHA2, RHQ4, RH2, RH26, RMG2, RX, RXU, RX2, RX4, SD, SDB1, SDB2, SDN, SD4, SH, SHQ4, SJ, SJG, SMC4, SMG1, SM11, SM12, SM14, SM21, SM22, SM24, SX, SXE4, SXU, SX4, SX7, TX, TXE, TXU, TXU1, TX2, TX4, UX, VAA, VAA1, VA2, VEE1, VEN, VEN1, VEN4, VES, VES1, VGG2, VMG1, VMT, VNG4, VSD, VSD1, VSD2, VSD7, VS17, VX, VXU, VX1, VX2, VX4
			-	2	2		

Ref. No.	Part No.	Description	Reqd. QTY			Serial No.	Parts catalogue code
			(1)	GX200 (2)	(3)		
6	28433-ZH8-003	GUIDE, RATCHET	1	-	-	-----	BL, HX, HXQ, HXU, HX2, HX26, HX4, LD, LDB1, LDB2, LDN, LD4, LH, LHB2, LHP1, LHQ4, LJ, LJC1, LJG, LSJ, LX, LX2, LX4, NAX, NAX1, NDF1, NDJ, NJ, NJC1, NJG, NMB, NTB, NW, NWA, NWB2, NX, PMX, PX, PXU, PX2, QA, QAB2, QA2, QD, QG, QG2, QH, QHP1, QHQ4, QH26, QH4, QJF, QJF1, QM, QSW4, QT, QTP, QTP2, QX, QXB2, QXC, QXC9, QXE, QXE2, QXE4, QXE6, QXE8, QXF, QXF2, QXH4, QXQ, QXS2, QXU, QX2, QX26, QX4, QX7, RG, RH, RHA2, RHQ4, RH2, RH26, RMG2, RX, RXU, RX2, RX4, SD, SDB1, SDB2, SDN, SD4, SH, SHQ4, SJ, SJG, SMC4, SMG1, SM11, SM12, SM14, SM21, SM22, SM24, SX, SXE4, SXU, SX4, SX7, TX, TXE, TXU, TXU1, TX2, TX4, UX, VAA, VAA1, VA2, VEE1, VEN, VEN1, VEN4, VES, VES1, VGG2, VMG1, VMT, VNG4, VSD, VSD1, VSD2, VSD7, VS17, VX, VXU, VXU1, VX2, VX4
7	28441-ZH8-003	SPRING, FRICTION	1	-	-	-----	BL, HX, HXQ, HXU, HX2, HX26, HX4, LD, LDB1, LDB2, LDN, LD4, LH, LHB2, LHP1, LHQ4, LJ, LJC1, LJG, LSJ, LX, LX2, LX4, NAX, NAX1, NDF1, NDJ, NJ, NJC1, NJG, NMB, NTB, NW, NWA, NWB2, NX, PMX, PX, PXU, PX2, QA, QAB2, QA2, QD, QG, QG2, QH, QHP1, QHQ4, QH26, QH4, QJF, QJF1, QM, QSW4, QT, QTP, QTP2, QX, QXB2, QXC, QXC9, QXE, QXE2, QXE4, QXE6, QXE8, QXF, QXF2, QXH4, QXQ, QXS2, QXU, QX2, QX26, QX4, QX7, RG, RH, RHA2, RHQ4, RH2, RH26, RMG2, RX, RXU, RX2, RX4, SD, SDB1, SDB2, SDN, SD4, SH, SHQ4, SJ, SJG, SMC4, SMG1, SM11, SM12, SM14, SM21, SM22, SM24, SX, SXE4, SXU, SX4, SX7, TX, TXE, TXU, TXU1, TX2, TX4, UX, VAA, VAA1, VA2, VEE1, VEN, VEN1, VEN4, VES, VES1, VGG2, VMG1, VMT, VNG4, VSD, VSD1, VSD2, VSD7, VS17, VX, VXU, VXU1, VX2, VX4
8	28442-ZH8-003	SPRING, RECOIL STARTER	1	-	-	-----	BL, HX, HXQ, HXU, HX2, HX26, HX4, LD, LDB1, LDB2, LDN, LD4, LH, LHB2, LHP1, LHQ4, LJ, LJC1, LJG, LSJ, LX, LX2, LX4, NAX, NAX1, NDF1, NDJ, NJ, NJC1, NJG, NMB, NTB, NW, NWA, NWB2, NX, PMX, PX, PXU, PX2, QA, QAB2, QA2, QD, QG, QG2, QH, QHP1, QHQ4, QH26, QH4, QJF, QJF1, QM, QSW4, QT, QTP, QTP2, QX, QXB2, QXC, QXC9, QXE, QXE2, QXE4, QXE6, QXE8, QXF, QXF2, QXH4, QXQ, QXS2, QXU, QX2, QX26, QX4, QX7, RG, RH, RHA2, RHQ4, RH2, RH26, RMG2, RX, RXU, RX2, RX4, SD, SDB1, SDB2, SDN, SD4, SH, SHQ4, SJ, SJG, SMC4, SMG1, SM11, SM12, SM14, SM21, SM22, SM24, SX, SXE4, SXU, SX4, SX7, TX, TXE, TXU, TXU1, TX2, TX4, UX, VAA, VAA1, VA2, VEE1, VEN, VEN1, VEN4, VES, VES1, VGG2, VMG1, VMT, VNG4, VSD, VSD1, VSD2, VSD7, VS17, VX, VXU, VXU1, VX2, VX4
9	28443-ZH8-003	SPRING, RETURN	2	-	-	-----	BL, HX, HXQ, HXU, HX2, HX26, HX4, LD, LDB1, LDB2, LDN, LD4, LH, LHB2, LHP1, LHQ4, LJ, LJC1, LJG, LSJ, LX, LX2, LX4, NAX, NAX1, NDF1, NDJ, NJ, NJC1, NJG, NMB, NTB, NW, NWA, NWB2, NX, PMX, PX, PXU, PX2, QA, QAB2, QA2, QD, QG, QG2, QH, QHP1, QHQ4, QH26, QH4, QJF, QJF1, QM, QSW4, QT, QTP, QTP2, QX, QXB2, QXC, QXC9, QXE, QXE2, QXE4, QXE6, QXE8, QXF, QXF2, QXH4, QXQ, QXS2, QXU, QX2, QX26, QX4, QX7, RG, RH, RHA2, RHQ4, RH2, RH26, RMG2, RX, RXU, RX2, RX4, SD, SDB1, SDB2, SDN, SD4, SH, SHQ4, SJ, SJG, SMC4, SMG1, SM11, SM12, SM14, SM21, SM22, SM24, SX, SXE4, SXU, SX4, SX7, TX, TXE, TXU, TXU1, TX2, TX4, UX, VAA, VAA1, VA2, VEE1, VEN, VEN1, VEN4, VES, VES1, VGG2, VMG1, VMT, VNG4, VSD, VSD1, VSD2, VSD7, VS17, VX, VXU, VXU1, VX2, VX4
10	28461-ZH8-003	GRIP, STARTER	1	-	-	-----	BL, HX, HXQ, HXU, HX2, HX26, HX4, LD, LDB1, LDB2, LDN, LD4, LH, LHB2, LHP1, LHQ4, LJ, LJC1, LJG, LSJ, LX, LX2, LX4, NAX, NAX1, NDF1, NDJ, NJ, NJC1, NJG, NMB, NTB, NW, NWA, NWB2, NX, PMX, PX, PXU, PX2, QA, QAB2, QA2, QD, QG, QG2, QH, QHP1, QHQ4, QH26, QH4, QJF, QJF1, QM, QSW4, QT, QTP, QTP2, QX, QXB2, QXC, QXC9, QXE, QXE2, QXE4, QXE6, QXE8, QXF, QXF2, QXH4, QXQ, QXS2, QXU, QX2, QX26, QX4, QX7, RG, RH, RHA2, RHQ4, RH2, RH26, RMG2, RX, RXU, RX2, RX4, SD, SDB1, SDB2, SDN, SD4, SH, SHQ4, SJ, SJG, SMC4, SMG1, SM11, SM12, SM14, SM21, SM22, SM24, SX, SXE4, SXU, SX4, SX7, TX, TXE, TXU, TXU1, TX2, TX4, UX, VAA, VAA1, VA2, VEE1, VEN, VEN1, VEN4, VES, VES1, VGG2, VMG1, VMT, VNG4, VSD, VSD1, VSD2, VSD7, VS17, VX, VXU, VXU1, VX2, VX4
			-	1	1		



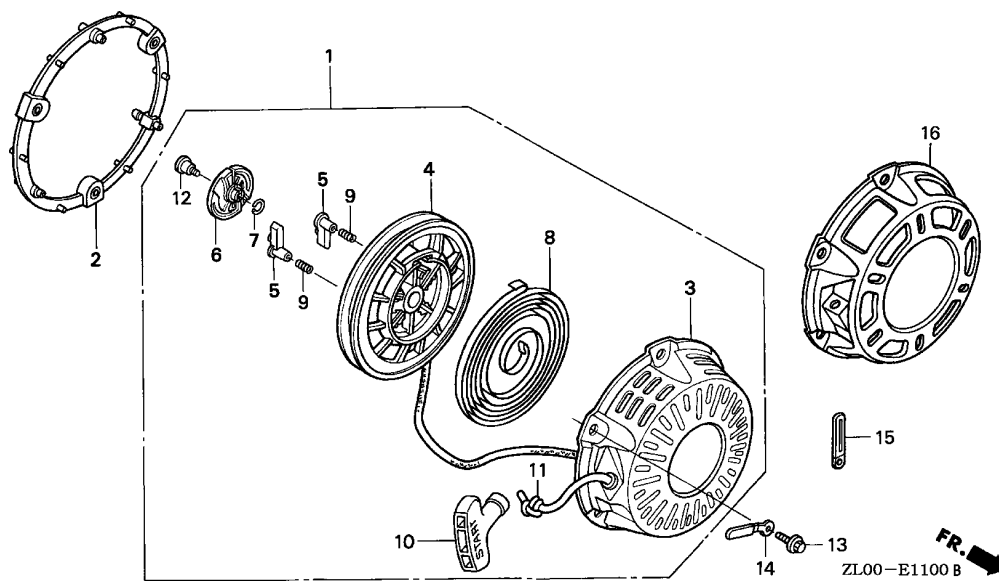

Ref. No.	Part No.	Description	Reqd. QTY			Serial No.	Parts catalogue code
			(1)	(2)	(3)		
11	28462-ZH8-003	ROPE, RECOIL STARTER	1	-	-	-----	BL, HX, HXQ, HXU, HX2, HX26, HX4, LD, LDB1, LDB2, LDN, LD4, LH, LHB2, LHP1, LHQ4, LJ, LJC1, LJG, LSJ, LX, LX2, LX4, NDF1, NDJ, NJ, NJC1, NJG, NMB, NTB, NW, NWA, NWB2, NX, PMX, PX, PXU, PX2, QA, QAB2, QA2, QD, QG, QG2, QH, QHP1, QHQ4, QH26, QH4, QJF, QJF1, QM, QSW4, QT, QTP, QTP2, QX, QXB2, QXC, QXC9, QXE, QXE2, QXE4, QXE6, QXE8, QXF, QXF2, QXH4, QXQ, QXS2, QXU, QX2, QX26, QX4, QX7, RG, RH, RHA2, RHQ4, RH2, RH26, RMG2, RX, RXU, RX2, RX4, SD, SDB1, SDB2, SDN, SD4, SH, SHQ4, SJ, SJG, SMC4, SMG1, SM11, SM12, SM14, SM21, SM22, SM24, SX, SXE4, SXU, SX4, SX7, TX, TXE, TXU, TXU1, TX2, TX4, UX, VAA, VAA1, VA2, VEE1, VEN, VEN1, VEN4, VES, VES1, VGG2, VMG1, VMT, VNG4, VSD, VSD1, VSD2, VSD7, VS17, VX, VXU, VXU1, VX2, VX4
	28462-ZH8-R10	-	1	1	-----	NAX, NAX1
12	90003-ZH8-003	SCREW, SETTING	1	-	-	-----	BL, HX, HXQ, HXU, HX2, HX26, HX4, LD, LDB1, LDB2, LDN, LD4, LH, LHB2, LHP1, LHQ4, LJ, LJC1, LJG, LSJ, LX, LX2, LX4, NAX, NAX1, NDF1, NDJ, NJ, NJC1, NJG, NMB, NTB, NW, NWA, NWB2, NX, PMX, PX, PXU, PX2, QA, QAB2, QA2, QD, QG, QG2, QH, QHP1, QHQ4, QH26, QH4, QJF, QJF1, QM, QSW4, QT, QTP, QTP2, QX, QXB2, QXC, QXC9, QXE, QXE2, QXE4, QXE6, QXE8, QXF, QXF2, QXH4, QXQ, QXS2, QXU, QX2, QX26, QX4, QX7, RG, RHA2, RHQ4, RH2, RH26, RMG2, RX, RXU, RX2, RX4, SD, SDB1, SDB2, SDN, SD4, SH, SHQ4, SJ, SJG, SMC4, SMG1, SM11, SM12, SM14, SM21, SM22, SM24, SX, SXE4, SXU, SX4, SX7, TX, TXE, TXU, TXU1, TX2, TX4, UX, VAA, VAA1, VA2, VEE1, VEN, VEN1, VEN4, VES, VES1, VGG2, VMG1, VMT, VNG4, VSD, VSD1, VSD2, VSD7, VS17, VX, VXU, VXU1, VX2, VX4
13	95701-06008-00	BOLT, FLANGE, 6X8	-	1	1	-----	1516303 BL
	90008-ZE2-003	BOLT, FLANGE, 6X10	3	-	-	-----	1516304 BL

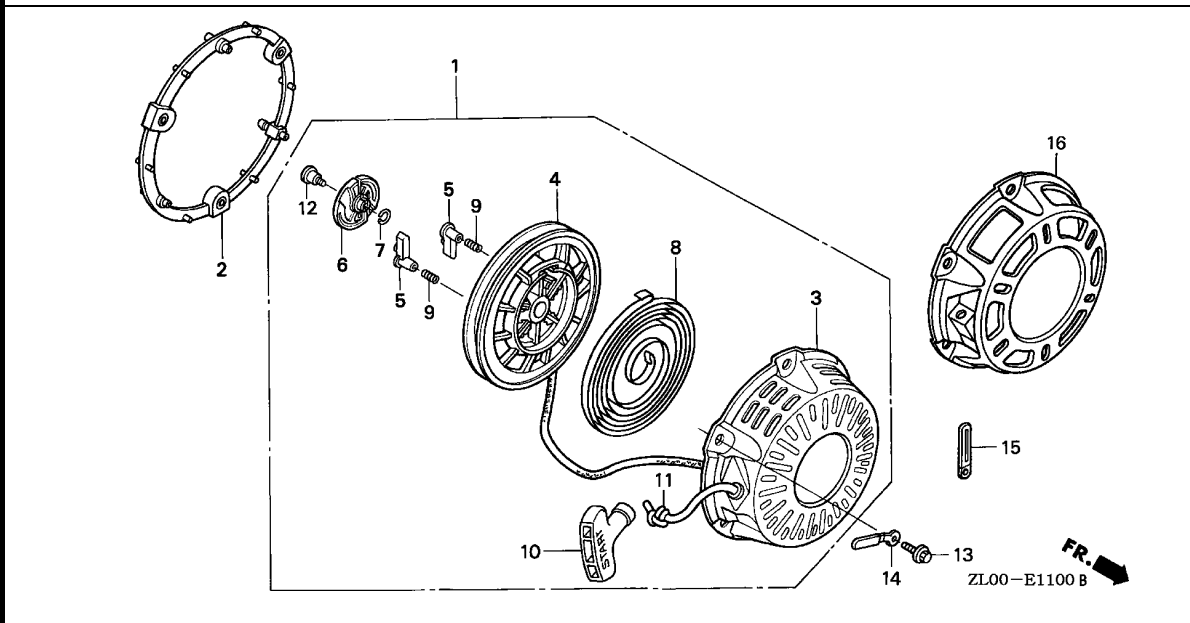

Ref. No.	Part No.	Description	Reqd. QTY			Serial No.	Parts catalogue code
			(1)	GX200 (2)	(3)		
13)	95701-06018-00	BOLT, FLANGE, 6X18	3	-	-	-----	HX, HXQ, HXU, HX2, HX26, HX4, LD, LDB1, LDB2, LDN, LD4, LH, LHB2, LHP1, LHQ4, LJ, LJC1, LJG, LSJ, LX, LX2, LX4, NAX, NAX1, NDF1, NDJ, NJ, NJC1, NJG, NMB, NTB, NWA, NWB2, NX, PMX, PX, PXU, PX2, QA, QAB2, QA2, QD, QG, QG2, QH, QHP1, QHQ4, QH26, QH4, QJF, QJF1, QM, QSW4, QT, QTP, QTP2, QX, QXB2, QXC, QXC9, QXE, QXE2, QXE4, QXE6, QXE8, QXF, QXF2, QXH4, QXQ, QXS2, QXU, QX2, QX26, QX4, QX7, RG, RHA2, RHQ4, RH2, RH26, RMG2, RX, RXU, RX2, RX4, SD, SDB1, SDB2, SDN, SD4, SH, SHQ4, SJ, SJG, SMC4, SMG1, SM11, SM12, SM14, SM21, SM22, SM24, SWG4, SX, SXE4, SXU, SX4, SX7, TX, TXE, TXU, TXU1, TX2, TX4, UX, VAA, VAA1, VA2, VEE1, VEN, VEN1, VEN4, VES, VES1, VGG2, VMG1, VMT, VNG4, VSD, VSD1, VSD2, VSD7, VS17, VX, VXU, VXU1, VX2, VX4
14	32901-MA1-000	CLIP, SUB CORD	1	-	3	-----	SM11, SM12, SM14
15	91406-671-000	CLIP, WIRE HARNESS	1	-	-	-----	SMG1, SMG2
16	28414-ZK8-V70	CASE B, STARTER	1	-	-	-----	1812939 SWG4
	28414-ZK8-V71	1	-	-	-----	1812940 SWG4



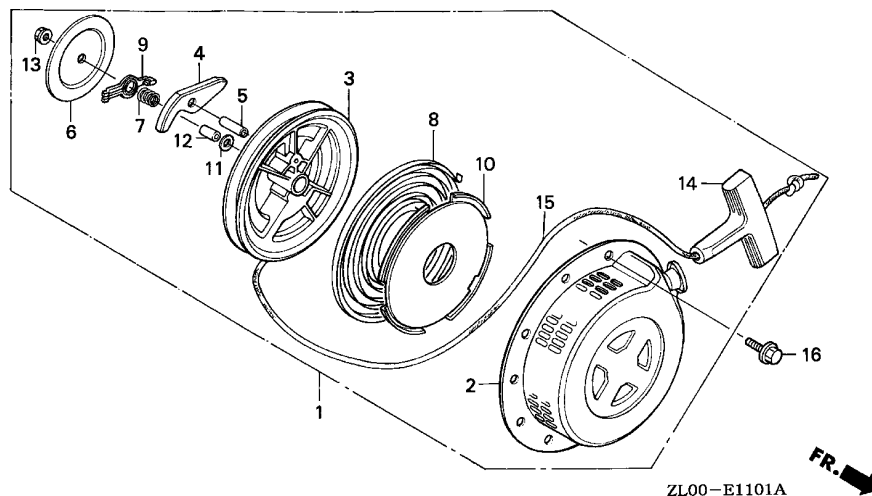

Ref. No.	L.O.N.	(Relative ref. Number) Description	F.R.T.
1	1121B9	STARTER, RECOIL	0.1
2	1121A1	CASE, RECOIL STARTER	0.1
3	1121B1	REEL, RECOIL STARTER	0.3
4	1121B0	RATCHET, STARTER AND/OR SPRING, RATCHET	0.2
8	1121B7	SPRING, RECOIL STARTER RETURN	0.3
15	1121B3	ROPE, RECOIL STARTER	0.3

Ref. No.	Part No.	Description	Reqd. QTY			Serial No.	Parts catalogue code
			(1)	(2)	(3)		
1	28400-ZE1-003ZA	STARTER ASSY., RECOIL	1	-	-	1812939	LVL,QVL
		R8.....BRIGHT RED	1	-	-	1812940	LVL,QVL
	28400-ZE1-003ZF	*R280*.....POWER RED	1	-	-	1812940	LVL,QVL
2	28410-ZE1-003ZA	CASE COMP., RECOIL STARTER	1	-	-	1812939	LVL,QVL
		R8.....BRIGHT RED	1	-	-	1812940	LVL,QVL
	28410-ZE1-003ZF	*R280*.....POWER RED	1	-	-	1812940	LVL,QVL
3	28420-ZE1-003	PULLEY, RECOIL STARTER	1	-	-	-----	LVL,QVL
4	28422-ZE1-003	RATCHET, STARTER	1	-	-	-----	LVL,QVL
5	28423-ZE1-003	PIN, STARTER RATCHET	1	-	-	-----	LVL,QVL
6	28431-ZE1-003	PLATE, FRICTION	1	-	-	-----	LVL,QVL
7	28441-ZE1-003	SPRING, FRICTION	1	-	-	-----	LVL,QVL
8	28442-ZE1-003	SPRING, RECOIL STARTER	1	-	-	-----	LVL,QVL
9	28443-ZE1-003	GUIDE, RATCHET	1	-	-	-----	LVL,QVL
10	28445-ZE1-003	CASE, RECOIL STARTER SPRING	1	-	-	-----	LVL,QVL
11	28446-ZE1-003	WASHER, STARTER	1	-	-	-----	LVL,QVL
12	28447-ZE1-003	SHAFT, SUB	1	-	-	-----	LVL,QVL
13	28448-ZE1-003	NUT	1	-	-	-----	LVL,QVL
14	28461-ZE1-003	KNOB, RECOIL STARTER	1	-	-	-----	LVL,QVL
15	28462-ZE1-003	ROPE, RECOIL STARTER	1	-	-	-----	LVL,QVL
16	90008-ZE2-003	BOLT, FLANGE, 6X10	3	-	-	-----	LVL,QVL

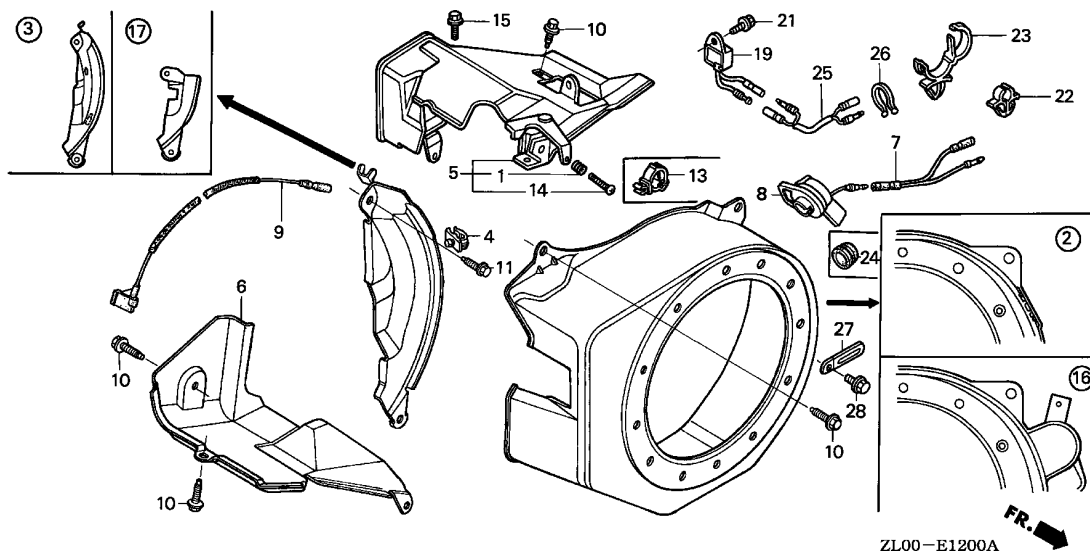

Ref. No.	L.O.N.	(Relative ref. Number) Description	F.R.T.
2		(16)	
1141G8		COVER, ENGINE COOLING FAN	0.2
3		(17)	
1121A7		PLATE, SIDE	0.2
5	4141E2	SHROUD, ENGINE :UPPER	0.2
6	4141E0	SHROUD, ENGINE :LOWER	0.1
7	6111A3	CORD, ENGINE STOP SWITCH	0.1
8	6151D9	SWITCH, ENGINE STOP	0.1
9	6111B3	CORD, STOP SWITCH	0.2
19	6151A0	ALERT UNIT, OIL	0.1

Ref. No.	Part No.	Description	Reqd. QTY			Serial No.	Parts catalogue code
			(1)	(2)	(3)		
1	16584-883-300	SPRING, CONTROL ADJUSTING ...	1	-	-	-----	VAA,VAA1,VEN,VEN4,VES,VMT
2	19610-ZL0-000ZA	COVER COMP., FAN *NH246*.....LOOSEY GRAY	1	-	-	-----	HX,HXQ,HXU,HX2,HX4,LD,LD4,LHQ4,LJ,LJG,LX,LX2,LX4,NX,PX2,QA,QA2,QD,QHQ4,QM,QT,QXC,QXC9,QXF,QXF2,QXQ,QXS2,QX2,RHQ4,RH2,RX,RXU,RX4,SD,SD4,SH,SHQ4,SJ,SJG,TX2,TX4,UX,VA2,VSD,VXU,VXU1,VX2
	19610-ZL0-000ZB	*R8*.....BRIGHT RED	1	-	-	-----	HXQ,HX4,LD,LDB1,LDB2,LDN,LD4,LJ,LJG,LSJ,LX,NAX,NDF1,NJ,NWA,NWB2,PMX,PX2,QA,QA2,QG,QT,QXC,QXF,QXF2,QXQ,RG,SDB1,SDN,SD4,SJ,TX4,UX,VAA,VAA1,VA2
			1	-	-	1812939	BL,HX,HXU,HX2,HX26,LH,LHB2,LHP1,LHQ4,LJC1,LVL,LX2,LX4,NDJ,NJG,NTB,NW,NX,PX,PXU,QAB2,QD,QG2,QH,QHP1,QHQ4,QH26,QJF,QM,QTP,QVL,QX,QXB2,QXC9,QXS2,QXU,QX2,QX26,QX4,QX7,RH,RHA2,RHQ4,RH2,RH26,RMG2,RX,RXU,RX2,RX4,SD,SDB2,SH,SHQ4,SJG,SMC4,SM11,SM12,SM14,SM21,SM22,SM24,SX,SXU,SX4,SX7,TX,TXU,TX2,VEE1,VGG2,VMG1,VMT,VSD,VSD1,VSD2,VSD7,VS17,VX,VXU,VXU1,VX2,VX4
	19610-ZL0-000ZD	*NH1*.....BLACK	1	-	-	-----	QJF,QX2,SM12,SM14,SM22,VEE1,VEN,VEN1,VEN4,VES,VES1,VMG1,VSD,VSD7
	19610-ZL0-000ZE	*T73*.....EXEN GRAY	1	-	-	-----	VEE1
	19610-ZL0-000ZF	*T38*.....MAT GREEN	1	-	-	-----	VSD
	19610-ZL0-000ZG	*T83*.....GEKO BLUE 2	1	-	-	-----	VNG4,VSD,VX4
	19610-ZL0-820ZC	*R8*.....BRIGHT RED	1	-	-	-----	NAX1,NMB
			1	-	-	1841772	NJC1,NTU,SMG1,SMG2,SWG4
	19610-ZL0-000ZJ	*R280*.....POWER RED	1	-	-	1812940	BL,HX,HXU,HX2,HX26,LH,LHB2,LHP1,LHQ4,LJC1,LVL,LX2,LX4,NDJ,NJG,NTB,NW,NX,PX,PXU,QAB2,QD,QG2,QH,QHP1,QHQ4,QH26,QJF,QM,QTP,QVL,QX,QXB2,QXC9,QXS2,QXU,QX2,QX26,QX4,QX7,RH,RHA2,RHQ4,RH2,RH26,RMG2,RX,RXU,RX2,RX4,SD,SDB2,SH,SHQ4,SJG,SMC4,SM11,SM12,SM14,SM21,SM22,SM24,SX,SXU,SX4,SX7,TX,TXU,TX2,VEE1,VGG2,VMG1,VMT,VSD,VSD1,VSD2,VSD7,VS17,VX,VXU,VXU1,VX2,VX4
	19610-ZL0-820ZF	*R280*.....POWER RED	1	-	-	1841773	NJC1,NTU,SMG1,SMG2,SWG4



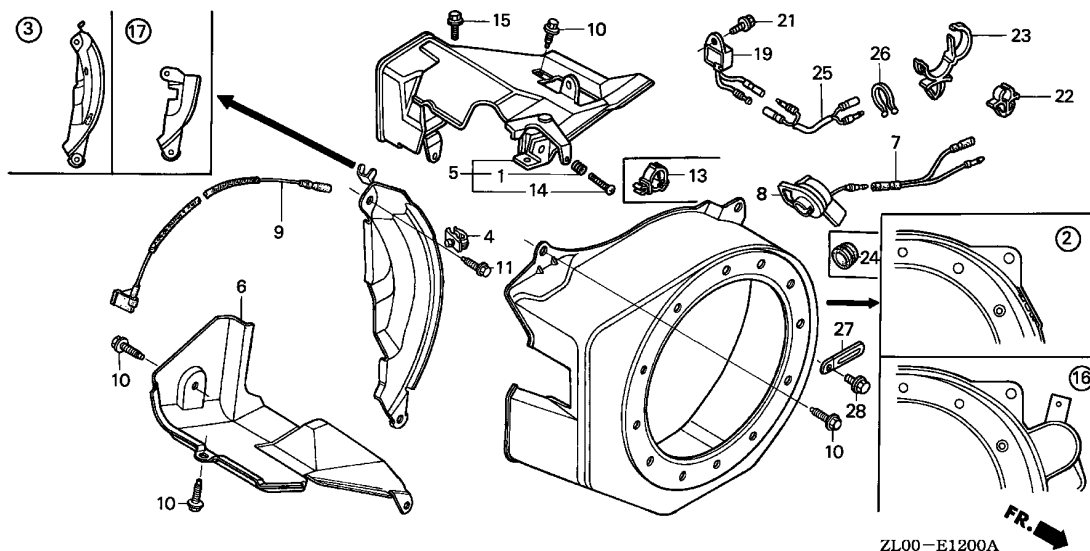

Ref. No.	Part No.	Description	Reqd. QTY			Serial No.	Parts catalogue code
			(1)	(2)	(3)		
3	19612-ZH8-000	PLATE, SIDE (STD.)	1	-	-		BL,LD,LDB1,LDB2,LDN,LD4,LH,LHB2,LHP1,LHQ4,LJ,LJG,LVL,NDF1,NDJ,NJ,NJG,NW,NWB2,QA,QAB2,QA2,QD,QG,QH,QHP1,QHQ4,QH26,QJF,QJF1,QM,QT,QVL,QXB2,RG,RH,RHQ4,RH2,RH26,SD,SDB1,SDB2,SDN,SD4,SH,SHQ4,SJ,SJG,SM11
	19612-ZH8-810	PLATE, SIDE (OIL ALERT)	1	-	1	1110329	HX,HXQ,HX2,HX26,HX4,LSJ,LX,LX2,LX4,NX,PMX,PX,PX2,QX,QXC,QXC9,QXF,QXF2,QXQ,QX2,QX26,QX4,RX,RX4,SX,SX4,TX,TX2,TX4,UX,VAA,VA2,VEE1,VGG2,VSD,VSD1,VX,VXU,VX2,VX4
	19612-ZH8-811		1	-	1	1110330	1000027 HXQ,QXF,QXQ,TX4,UX
			1	-	1	1110330	1127340 HX,HX2,HX26,HX4,LSJ,LX,LX2,LX4,NX,PMX,PX,PX2,QX,QXC,QXC9,QXF2,QX2,QX26,QX4,RX,RX4,SX,SX4,TX,TX2,VAA,VA2,VEE1,VGG2,VSD,VSD1,VX,VXU,VX2,VX4
	19612-ZH8-812		1	-	1	1110330	1144320 LX2
			1	-	1	1000028	1000087
			1	-	1	1584578	QG2
			1	-	1	1127341	1156170 HX,HX2,HX26,HX4,LSJ,LX,LX4,NX,PMX,PX,PX2,QX,QXC,QXC9,QXF2,QX2,QX26,QX4,RX,RX4,SX,SX4,TX,TX2,VAA,VA2,VEE1,VGG2,VSD,VSD1,VX,VXU,VX2,VX4
	19611-ZH8-810	PLATE COMP., SIDE (OIL ALERT)	1	-	1	1144321	1156170 LX2
			1	-	1		HXU,LJC1,PXU,QXU,QX7,RXU,RX2,SM12,SM14,SM21,SM22,SM24,SXU,SX7,TXU,VAA1,VEN1,VMG1,VMT,VNG4,VSD2,VSD7,VS17,VXU1
			1	-	1	1156171	HX,HX2,HX26,HX4,LSJ,LX,LX2,LX4,NX,PMX,PX,PX2,QX,QXC,QXC9,QXF2,QX2,QX26,QX4,RX,RX4,SX,SX4,TX,TX2,VAA,VA2,VEE1,VGG2,VSD,VSD1,VX,VXU,VX2,VX4
			1	-	1	1584578	QG2
			-	1	-	1000088	

Ref. No.	Part No.	Description	Reqd. QTY			Serial No.	Parts catalogue code	
			(1)	GX200 (2)	(3)			
(3)	19611-ZH8-820	PLATE COMP., SIDE (ALERT & LAMP)	1	-	-	-----	VES,VES1	
			1	-	-	1156171	-----	QXS2,SMC4,VEN,VEN4
			1	-	-	1584579	-----	QG2
	19612-ZH8-812	PLATE, SIDE (OIL ALERT)	1	-	-	-----	VSD2	
	19612-ZH8-820	PLATE, SIDE (LAMP)	1	-	-	1127340	-----	NAX,NTB,NWA,QTP,RHA2,RMG2,VEN4
			1	-	-	1100330	-----	1127340 VEN
			1	-	-	1110330	-----	1127340 QXS2,SMC4
	19612-ZH8-821	1	-	-	1127341	-----	NAX,NTB,NWA,QTP,RHA2,RMG2
			1	-	-	1584579	-----	QG2
			1	-	-	1127341	-----	1156170 QXS2,SMC4,VEN,VEN4
	19612-ZH8-830	PLATE, SIDE (ALERT & LAMP) ..	1	-	-	-----	1100329 VEN	
			1	-	-	-----	1110329 QXS2,SMC4	
4	19613-ZE1-000	CLAMPER, CORD	1	-	-	-----	QA,QA2,RHA2,RH2	
			1	-	-	-----	1061455 HX,HXQ,HX2,HX26,HX4,LSJ,LX,LX2,LX4,NX,PX,PX2,QX,QXC,QXC9,QXF,QXF2	
							-----	QXQ,QXS2,QX2,QX26,QX4,RX,RX4,SMC4,SX,SX4,TX,TX2,UX,VA2,VEN
							-----	VGG2,VSD,VX,VXU,VX2,VX4
	19613-ZE1-020	CLAMP, CORD	-	1	-	-----	1061455	
5	19620-ZLO-V30	SHROUD ASSY., UPPER	1	-	-	-----	SM22,SM24	
			1	-	-	-----	VAA,VAA1,VEN,VEN4,VES,VMT	
6	19630-ZH8-000	SHROUD COMP.	1	-	-	-----	BL,HX,HXQ,HXU,HX2,HX26,HX4,LD,LDB1,LDB2,LDN,LD4,LH,LHB2,LHP1,LHQ4	
							-----	LJ,LJC1,LJG,LSJ,LVL,LX,LX2,LX4,NAX,NAX1,NDF1,NDJ,NJ,NJG,NMB,NTB
							-----	NTU,NW,NWA,NWB2,NX,PMX,PX,PXU,PX2,QA,QAB2,QA2,QD,QG,QG2,QH,QHP1
							-----	QH4,QH26,QH4,QJF,QM,QSW4,QT,QTP,QTP2,QVL,QX,QXB2,QXC,QXC9,QXE
							-----	QXE2,QXE4,QXE6,QXE8,QXF,QXF2,QXH4,QXQ,QXS2,QXU,QX2,QX26,QX4,QX7
							-----	RG,RH,RHA2,RHQ4,RH2,RH26,RMG2,RX,RXU,RX2,RX4,SD,SDB1,SDB2,SDN,SD4
							-----	SH,SHQ4,SJ,SJG,SMC4,SMG1,SMG2,SM11,SM12,SM14,SM21,SM22,SM24,SWG4
							-----	SX,SXE4,SXU,SX4,SX7,TX,TXE,TXU,TXU1,TX2,UX,VA2,VEE1,VEN1,VES1
							-----	VGG2,VMG1,VNG4,VSD,VSD1,VSD2,VSD7,VS17,VX,VXU,VXU1,VX2,VX4
	19640-ZLO-V30	SHROUD COMP., LOWER	-	1	1	-----	VAA,VAA1,VEN,VEN4,VES,VMT	
7	32197-ZH8-003	SUB HARNESS	1	-	-	-----	QA,QA2,RHA2,RH2,SM22,SM24,VAA1,VGG2	
			1	-	-	-----	1061455 HX,HXQ,HX2,HX26,HX4,LSJ,LX,LX2,LX4,NX,PX,PX2,QX,QXC,QXC9,QXF,QXF2	
							-----	QXQ,QXS2,QX2,QX26,QX4,RX,RX4,SMC4,SX,SX4,TX,TX2,UX,VA2,VEN
							-----	VSD,VX,VXU,VX2,VX4
			-	1	-	-----	1061455	
8	36100-ZE1-015	SWITCH ASSY., ENGINE STOP ...	1	1	-	-----	BL,LD,LDB1,LDB2,LDN,LH,LHB2,LHP1,LJ,LJG,LVL,NAX,NDF1,NDJ,NJ,NJG	
							-----	NTB,NW,NWA,NWB2,QA,QAB2,QA2,QD,QH,QHP1,QH26,QJF,QM,QT,QTP,QVL,RH
							-----	RHA2,RH2,RH26,RMG2,SD,SDB1,SDB2,SDN,SH,SJ,SJG,SM11,VAA1,VXP
			1	-	-	-----	1061455 HX,HXQ,HX2,HX26,LSJ,LX,LX2,NX,PX,PX2,QX,QXC,QXC9,QXF,QXF2,QXQ	
							-----	QXS2,QX2,QX26,RX,SX,TX,TX2,UX,VA2,VEN,VGG2,VX,VXU,VX2
			-	-	1	-----	1061455	
	36100-ZH8-W41	1	1	-	-----	1061455 HX4,LX4,QX4,RX4,SMC4,SX4,UX,VSD,VX4,VX4P	
			1	-	-	-----	LD4,LHQ4,QG,QHQ4,RG,RHQ4,SD4,SHQ4	
	36100-ZH7-W41	1	1	-	-----	1061456 HX4,LX4,QX4,RX4,SMC4,SX4,UX,VSD,VX4,VX4P	
			1	-	-	-----	QX7,SM14,SX7,VEE1,VEN1,VNG4,VSD1,VSD7,VS17	
	36100-ZH7-003	1	1	-	-----	1061456 HX,HXQ,HX2,HX26,LSJ,LX,LX2,NX,PX,PX2,QX,QXC,QXC9,QXF,QXF2,QXQ	
							-----	QXS2,QX2,QX26,RX,SX,TX,TX2,UX,VA2,VEN,VGG2,VX,VXP,VXU,VX2
			1	-	-	-----	HXU,LJC1,PMX,PXU,QG2,QXU,RXU,RX2,SM12,SM21,SXU,TXU,VAA,VEN4,VES	
							-----	VES1,VMG1,VMT,VSD2,VXU1
	35120-Z0D-V81	1	-	-	-----	QXB2	



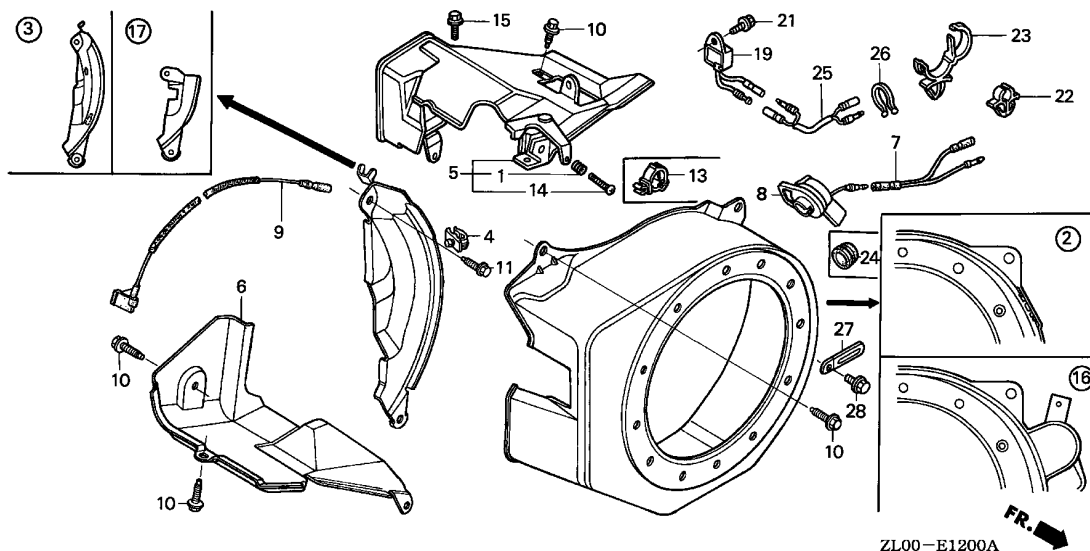

Ref. No.	Part No.	Description	Reqd. QTY			Serial No.	Parts catalogue code	
			(1)	(2)	(3)			
9	36101-ZE1-010	CORD, STOP SWITCH (370MM) ...	1	-	-	-----	BL, HX, HXQ, HXU, HX2, HX26, HX4, LD, LDB1, LDB2, LDN, LD4, LH, LHB2, LHP1, LHQ4, LJ, LJC1, LJG, LSJ, LVL, LX, LX2, LX4, NAX, NAX1, NDF1, NDJ, NJ, NJC1, NJG, NMB, NTB, NTU, NW, NWA, NWB2, NX, PMX, PX, PXU, PX2, QA, QAB2, QA2, QD, QG, QG2, QH, QHP1, QHQ4, QH26, QJF, QJF1, QM, QT, QTP, QVL, QX, QXB2, QXC, QXC9, QXF, QXF2, QXQ, QXS2, QXU, QX2, QX26, QX4, QX7, RG, RH, RHA2, RHQ4, RH2, RH26, RMG2, RX, RXU, RX2, RX4, SD, SDB1, SDB2, SDN, SD4, SH, SHQ4, SJ, SJG, SMC4, SMG1, SMG2, SM11, SM12, SM14, SM21, SM22, SM24, SX, SXU, SX4, SX7, TX, TXU, TX2, TX4, UX, VAA, VAA1, VA2, VEE1, VEN, VEN1, VEN4, VES, VES1, VGG2, VMG1, VMT, VNG4, VSD1, VSD2, VSD7, VS17, VX, VXU, VXU1, VX2, VX4	
			1	-	-	-----	1156170 QTP2	
	36101-ZB2-010	CORD, STOP SWITCH (395MM) ...	1	-	-	-----	QH4, QSW4, QXE, QXE2, QXE4, QXE6, QXE8, QXH4, SWG4, SXE4, TXE, TXU1	
			1	-	-	1156171	-----	QTP2
10	90013-883-000	BOLT, FLANGE, 6X12(CT200) ...	4	-	-	-----	NJC1, QJF1	
			6	-	-	-----	BL, HX, HXQ, HXU, HX2, HX26, HX4, LD, LDB1, LDB2, LDN, LD4, LH, LHB2, LHP1, LHQ4, LJ, LJC1, LJG, LSJ, LVL, LX, LX2, LX4, NAX, NAX1, NDF1, NDJ, NJ, NJC1, NJG, NMB, NTB, NTU, NW, NWA, NWB2, NX, PMX, PX, PXU, PX2, QA, QAB2, QA2, QD, QG, QG2, QH, QHP1, QHQ4, QH26, QH4, QJF, QM, QSW4, QT, QTP, QTP2, QVL, QX, QXB2, QXC, QXC9, QXE, QXE2, QXE4, QXE6, QXE8, QXF, QXF2, QXH4, QXQ, QXS2, QXU, QX2, QX26, QX4, QX7, RG, RH, RHA2, RHQ4, RH2, RH26, RMG2, RX, RXU, RX2, RX4, SD, SDB1, SDB2, SDN, SD4, SH, SHQ4, SJ, SJG, SMC4, SMG1, SMG2, SM11, SM12, SM14, SM21, SM22, SM24, SWG4, SX, SXE4, SXU, SX4, SX7, TX, TXE, TXU, TXU1, TX2, TX4, UX, VAA, VAA1, VEE1, VEN1, VES1, VGG2, VMG1, VNG4, VSD, VSD1, VSD2, VSD7, VS17, VX, VXU, VXU1, VX2, VX4	
			8	-	-	-----	VAA, VAA1, VEN, VEN4, VES, VMT	
			-	6	6	-----		

Ref. No.	Part No.	Description	Reqd. QTY			Serial No.	Parts catalogue code
			(1)	GX200 (2)	(3)		
11	90022-888-010	BOLT, FLANGE, 6X20(CT200) ...	1	-	-		BL, HX, HXQ, HXU, HX2, HX26, HX4, LD, LDB1, LDB2, LDN, LD4, LH, LHB2, LHP1, LHQ4, LJ, LJC1, LJG, LSJ, LVL, LX, LX2, LX4, NAX, NAX1, NDF1, NDJ, NJ, NJC1, NJG, NMB, NTB, NW, NWA, NWB2, NX, PMX, PX, PXU, PX2, QA, QAB2, QA2, QD, QG, QG2, QH, QHP1, QHQ4, QH26, QJF, QJF1, QM, QT, QTP, QVL, QX, QXB2, QXC, QXC9, QXF, QXF2, QXQ, QXS2, QXU, QX2, QX26, QX4, QX7, RG, RH, RHA2, RHQ4, RH2, RH26, RMG2, RX, RXU, RX2, RX4, SD, SDB1, SDB2, SDN, SD4, SH, SHQ4, SJ, SJG, SMC4, SM11, SM12, SM14, SM21, SM22, SM24, SX, SXU, SX4, SX7, TX, TXU, TX2, TX4, UX, VAA, VAA1, VA2, VEE1, VEN, VEN1, VEN4, VES, VES1, VGG2, VMG1, VMT, VNG4, VSD, VSD1, VSD2, VSD7, VS17, VX, VXU, VXU1, VX2, VX4
			-	1	1		
13	90601-ZH7-D02	CLIP, HARNESS	1	-	-		VEN4, VES
			1	-	-	1061456	VEN
	90601-ZH7-013	1	-	-		HXU, LJC1, PMX, PXU, QG2, QXU, QX7, RXU, RX2, SM12, SM14, SM21, SXU, SX7, TXU, VAA, VAA1, VEE1, VEN1, VES1, VMG1, VMT, VNG4, VSD1, VSD2, VSD7, VS17, VXU1
			1	-	-	1061456	HX, HXQ, HX2, HX26, HX4, LSJ, LX, LX2, LX4, NX, PX, PX2, QX, QXC, QXC9, QXF, QXF2, QXQ, QXS2, QX2, QX26, QX4, RX, RX4, SMC4, SX, SX4, TX, TX2, TX4, UX, VA2, VGG2, VSD, VX, VXU, VX2, VX4
			-	1	-	1061456	
14	93500-05035-0A	SCREW, PAN, 5X35	1	-	-		VAA, VAA1, VEN, VEN4, VES, VMT
15	95701-06008-00	BOLT, FLANGE, 6X8	1	-	-		VAA, VAA1, VEN, VEN4, VES, VMT
16	19610-ZLO-830ZA	COVER COMP., FAN					
		NH246.....LOOSEY GRAY	1	-	-		QXE, QXE2, QXE4
	19610-ZLO-830ZB	*R8*.....BRIGHT RED	1	-	-		QSW4, QXE, TXE
			1	-	-	1812939	QH4, QTP2, QXE2, QXE4, QXE6, QXH4, SXE4, TXU1
	19610-ZLO-830ZD	*R280*.....POWER RED	1	-	-		QXE8
			1	-	-	1812940	QH4, QTP2, QXE2, QXE4, QXE6, QXH4, SXE4, TXU1
17	19612-ZH8-840	PLATE, SIDE (STARTER MOTOR) -	1	-	-		NAX1, NJC1, NMB, NTU, QH4, QSW4, QTP2, QXE, QXE2, QXE4, QXE6, QXE8, QXH4, SMG1, SMG2, SWG4, SXE4, TXE, TXU1
19	34150-ZH7-003	ALERT UNIT, OIL	1	-	-		HXU, LJC1, PXU, QG2, QXU, QX7, RXU, RX2, SM12, SM14, SM21, SM22, SM24, SWG4, SXU, SX7, TXU, VAA1, VEN1, VES, VES1, VMG1, VMT, VNG4, VSD2, VSD7, VS17, VXU1
			1	-	-	1156171	HX, HX2, HX26, HX4, LSJ, LX, LX2, LX4, NX, PMX, PX, PX2, QX, QXC, QXC9, QXF2, QXS2, QX2, QX26, QX4, RX, RX4, SMC4, SX, SX4, TX, TX2, VAA, VA2, VEE1, VEN, VEN4, VGG2, VSD, VSD1, VX, VXU, VX2, VX4
			1	-	-	1289073	SMG1
			-	1	-		
21	95701-06008-00	BOLT, FLANGE, 6X8	1	-	-		HXU, LJC1, PXU, QG2, QXU, QX7, RXU, RX2, SM12, SM14, SM21, SM22, SM24, SXU, SX7, TXU, VAA1, VEN1, VES, VES1, VMG1, VMT, VNG4, VSD2, VSD7, VS17, VXU1
			1	-	-	1156171	HX, HX2, HX26, HX4, LSJ, LX, LX2, LX4, NX, PMX, PX, PX2, QX, QXC, QXC9, QXF2, QXS2, QX2, QX26, QX4, RX, RX4, SMC4, SX, SX4, TX, TX2, VAA, VA2, VEE1, VEN, VEN4, VGG2, VSD, VSD1, VX, VXU, VX2, VX4
			1	-	-	1289073	SMG1
			-	1	-		
22	90682-ZE1-000	CLIP, CORD	2	-	-	1156171	QTP2
23	90690-SA0-003	STRAP, WIRE HARNESS, 25MM (BLACK)	1	-	-	1156171	QTP2
24	81329-567-020	GROMMET, DRAIN HOLE	1	-	-		QJF1, SM22, SM24, VAA1
25	32105-ZH8-V10	CABLE, DOUBLE CONNECTOR	1	-	-		SWG4
			1	-	-	1289073	SMG1
26	90630-751-000	CLIP, PURSE LOCK	1	-	-		SWG4
			1	-	-	1289073	SMG1
27	91406-671-000	CLIP, WIRE HARNESS	1	-	-		SMG1
28	95701-06008-00	BOLT, FLANGE, 6X8	1	-	-		SMG1



E-14

CARBURETOR(1)

G 1

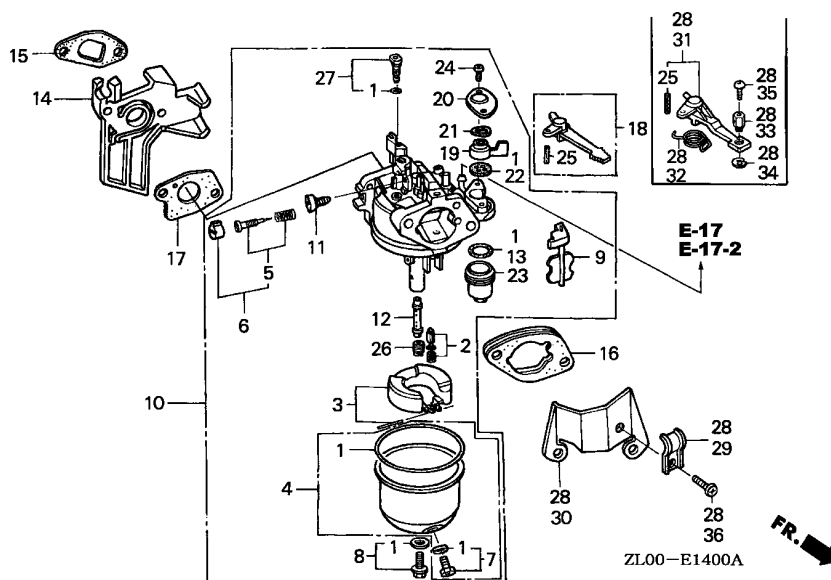

Ref. No.	L.O.N.	(Relative ref. Number) Description	F.R.T.
1	3111B1	GASKET SET, CARBURETOR (3)	0.3
2	3111E1	VALVE SET, FLOAT AND/OR FLOAT SET	0.3
6	3111D7	SCREW SET, PILOT	0.2
10	3111F3	CARBURETOR	0.2
13	3101L6	PACKING, FUEL STRAINER CUP (15)	0.2
14	3111C0	INSULATOR, CARBURETOR AND/OR PACKING, INSULATOR	0.2
17	3111C8	PACKING, CARBURETOR (31)	0.2
18	8101F9	LEVER, CARBURETOR CHOKE	0.2
22	3101C5	PACKING, FUEL COCK	0.2
26	3111C3	JET, MAIN	0.3

Ref. No.	Part No.	Description	Reqd. QTY			Serial No.	Parts catalogue code
			(1)	(2)	(3)		
1	16010-ZE1-812	GASKET SET	1	-	-	-	BL, HX, HXQ, HXU, HX2, HX26, HX4, LDN, LH, LHB2, LHP1, LHQ4, LJ, LJC1, LJG, LSJ, LVL, LX, LX2, LX4, NAX, NAX1, NDF1, NDJ, NJ, NJC1, NJG, NMB, NTB, NTU, NW, NWA, NWB2, NX, PMX, PX, PXU, PX2, QA, QAB2, QA2, QG, QG2, QH, QHP1, QHQ4, QH26, QH4, QJF, QJF1, QSW4, QT, QTP, QTP2, QVL, QX, QXB2, QXC, QXC9, QXE, QXE2, QXE4, QXE6, QXE8, QXF, QXF2, QXH4, QXQ, QXS2, QXU, QX2, QX26, QX4, QX7, RG, RH, RHA2, RHQ4, RH2, RH26, RMG2, RX, RXU, RX2, RX4, SDN, SH, SHQ4, SJ, SJG, SMC4, SM11, SM12, SM14, SM21, SM22, SM24, SWG4, SX, SXE4, SXU, SX4, SX7, TX, TXE, TXU, TXU1, TX2, TX4, UX, VA2, VEE1, VEN1, VES1, VGG2, VMG1, VNG4, VSD, VSD7, VX, VXU, VXU1, VX2, VX4
	16010-ZH7-A20		-	-	1	-	SMG1, SMG2
	16010-ZE0-025		1	-	-	-	LD, LDB1, LDB2, LD4, QD, QM, SD, SDB1, SDB2, SD4
2	16011-ZE0-005	VALVE SET, FLOAT	1	-	-	-	BL, HX, HXQ, HXU, HX2, HX26, HX4, LD, LDB1, LDB2, LDN, LD4, LH, LHB2, LHP1, LHQ4, LJ, LJC1, LJG, LSJ, LVL, LX, LX2, LX4, NAX, NAX1, NDF1, NDJ, NJ, NJC1, NJG, NMB, NTB, NTU, NW, NWA, NWB2, NX, PMX, PX, PXU, PX2, QA, QAB2, QA2, QD, QG, QG2, QH, QHP1, QHQ4, QH26, QH4, QJF, QJF1, QM, QSW4, QT, QTP, QTP2, QVL, QX, QXB2, QXC, QXC9, QXE, QXE2, QXE4, QXE6, QXE8, QXF, QXF2, QXH4, QXQ, QXS2, QXU, QX2, QX26, QX4, QX7, RG, RH, RHA2, RHQ4, RH2, RH26, RMG2, RX, RXU, RX2, RX4, SD, SDB1, SDB2, SDN, SD4, SH, SHQ4, SJ, SJG, SMC4, SMG1, SMG2, SM11, SM12, SM14, SM21, SM22, SM24, SWG4, SX, SXE4, SXU, SX4, SX7, TX, TXE, TXU, TXU1, TX2, TX4, UX, VA2, VEE1, VEN1, VES1, VGG2, VMG1, VNG4, VSD, VSD7, VX, VXU, VXU1, VX2, VX4
			-	-	1	-	

2

Ref. No.	Part No.	Description	Reqd. QTY			Serial No.	Parts catalogue code
			(1)	GX200 (2)	(3)		
3	16013-ZE0-005	FLOAT SET	1	-	-		BL, HX, HXQ, HXU, HX2, HX26, HX4, LD, LDB1, LDB2, LDN, LD4, LH, LHB2, LHP1, LHQ4, LJ, LJC1, LJG, LSJ, LVL, LX, LX2, LX4, NAX, NAX1, NDF1, NDJ, NJ, NJC1, NJG, NMB, NTB, NTU, NW, NWA, NWB2, NX, PMX, PX, PXU, PX2, QA, QAB2, QA2, QD, QG, QG2, QH, QHP1, QHQ4, QH26, QH4, QJF, QJF1, QM, QSW4, QT, QTP, QTP2, QVL, QX, QXB2, QXC, QXC9, QXE, QXE2, QXE4, QXE6, QXE8, QXF, QXF2, QXH4, QXQ, QXS2, QXU, QX2, QX26, QX4, QX7, RG, RH, RHA2, RHQ4, RH2, RH26, RMG2, RX, RXU, RX2, RX4, SD, SDB1, SDB2, SDN, SD4, SH, SHQ4, SJ, SJG, SMC4, SMG1, SMG2, SM11, SM12, SM14, SM21, SM22, SM24, SWG4, SX, SXE4, SXU, SX4, SX7, TX, TXE, TXU, TXU1, TX2, TX4, UX, VA2, VEE1, VEN1, VES1, VGG2, VMG1, VNG4, VSD, VSD7, VX, VXU, VXU1, VX2, VX4
4	16015-ZE1-811	CHAMBER SET, FLOAT	-	-	1		
		(CARBURETOR NO.)	1	-	-	BE64A	A HX, HX4, LH, LHB2, LHQ4, LX, LX4, NX, PX, QH, QHQ4, QX, QXE, QXE4, QXF, QX4, RH, RHQ4, RX, RX4, SH, SHQ4, SMC4, SX, SX4, TX, TXE, TX4, UX, VSD, VX, VXU, VX4
		//	1	-	-	BE64B	A HX2, HX26, LX2, PX2, QH26, QXE2, QXE6, QXF2, QXS2, QX2, QX26, RHA2, RH2, RH26, TX2, VA2, VX2
		//	1	-	-	BE64C	A LJ, LJG, LSJ, NAX, NAX1, NJ, NJG, NMB, NTB, QA, QAB2, QT, SJ, SJG
		//	1	-	-	BE64D	A HXQ, QXQ
		//	1	-	-	BE64E	A QA2
		//	1	-	-	BE64F	A QXC9
		//	1	-	-	BE64G	A QXC
		//	1	-	-	BE69A	A LD, LDB1, LDB2, LD4, QD, QM, SD, SDB1, SDB2, SD4
	16015-ZH7-A20	1	-	-	BE64R	A SMG1
	(CARBURETOR NO.)	1	-	-		BL, HXU, LDN, LHP1, LJC1, LVL, NDF1, NDJ, NJC1, NTU, NW, NWA, NWB2, PMX, PXU, QG, QG2, QHP1, QH4, QJF, QJF1, QSW4, QTP, QTP2, QVL, QXB2, QXE8, QXH4, QXU, QX7, RG, RMG2, RXU, RX2, SDN, SM11, SM12, SM14, SM21, SM22, SM24, SWG4, SXE4, SXU, SX7, TXU, TXU1, VEE1, VEN1, VES1, VGG2, VMG1, VNG4, VSD7, VXU1
	16015-ZE0-831	1	-	-	BE64A	B HX, HX4, LH, LHB2, LHQ4, LX, LX4, NX, PX, QH, QHQ4, QX, QXE, QXE4, QXF, QX4, RH, RHQ4, RX, RX4, SH, SHQ4, SMC4, SX, SX4, TX, TXE, TX4, UX, VSD, VX, VXU, VX4
		(CARBURETOR NO.)	1	-	-	BE64B	B HX2, HX26, LX2, PX2, QH26, QXE2, QXE6, QXF2, QXS2, QX2, QX26, RHA2, RH2, RH26, TX2, VA2, VX2
		//	1	-	-	BE64C	B LJ, LJG, LSJ, NAX, NAX1, NJ, NJG, NMB, NTB, QA, QAB2, QT, SJ, SJG
		//	1	-	-	BE64D	B HXQ, QXQ
		//	1	-	-	BE64E	B QA2
		//	1	-	-	BE64F	B QXC9
		//	1	-	-	BE64G	B QXC
		//	1	-	-	BE69A	B LD, LDB1, LDB2, LD4, QD, QM, SD, SDB1, SDB2, SD4
		//	-	-	1		
	16015-ZH7-A21	1	-	-		SMG2
	(CARBURETOR NO.)	1	-	-	BE64R	B SMG1
5	16016-ZE0-005	SCREW SET, PILOT	1	-	-		BL, LD, LDB1, LDB2, LDN, LD4, LJ, LJC1, LJG, LSJ, LVL, NAX, NAX1, NJ, NJC1, NJG, NMB, NTB, NTU, NW, NWA, NWB2, QA, QD, QJF, QJF1, QM, QT, QVL, QXE, QXF, SD, SDB1, SDB2, SDN, SD4, SJ, SJG, SMG2, TX4, UX
		(CARBURETOR NO.)	1	-	-	BE64A	B NDF1, NDJ, SM14, SM21, SM24, VMG1
		//	1	-	-	BE64B	A HX, HXU, HX4, LH, LHB2, LHP1, LHQ4, LX, LX4, NX, PMX, PX, PXU, QG, QH, QHP1, QHQ4, QSW4, QTP, QX, QXE4, QXU, QX4, RG, RH, RHQ4, RX, RXU, RX4, SH, SHQ4, SMC4, SX, SXE4, SXU, SX4, TX, TXE, TXU, TXU1, VNG4, VSD, VX, VXU, VXU1, VX4
		//	1	-	-	BE64C	B QAB2, VEE1
		//	1	-	-	BE64G	B QXC
		//	1	-	-	BE64R	A SMG1
		//	-	-	1		



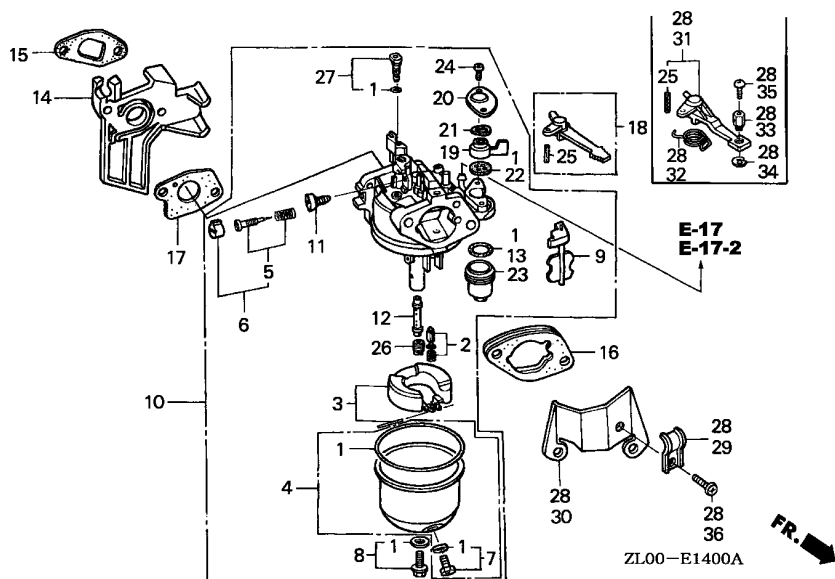

Ref. No.	Part No.	Description	Reqd. QTY			Serial No.	Parts catalogue code
			(1)	(2)	(3)		
6	16016-ZH7-W01	SCREW SET, PILOT	1	-	-	-----	HXQ, HX2, HX26, LX2, PX2, QA2, QG2, QH26, QH4, QTP2, QXB2, QXC9, QXE2, QXE6, QXE8, QXF2, QXH4, QXQ, QXS2, QX2, QX26, QX7, RHA2, RH2, RH26, RMG2, RX2, SM11, SM12, SM22, SWG4, SX7, TX2, VA2, VEN1, VES1, VGG2, VSD7, VX2
		(CARBURETOR NO.)	1	-	-	BE64B B	HX, HXU, HX4, LH, LHB2, LHP1, LHQ4, LX, LX4, NDF1, NDJ, NX, PMX, PX, PXU, QG, QH, QHP1, QHQ4, QSW4, QTP, QX, QXE4, QXU, QX4, RG, RH, RHQ4, RX, RXU, RX4, SH, SHQ4, SMC4, SM14, SM21, SM24, SX, SXE4, SXU, SX4, TX, TXE, TXU, TXU1, VEE1, VMG1, VNG4, VSD, VX, VXU, VXU1, VX4
		///	1	-	-	BE64E B	QAB2
		///	1	-	-	BE64F B	QXC
		///	1	-	-	BE64R B	SMG1
7	16024-ZE1-811	SCREW SET, DRAIN	1	-	-	-----	BL, HX, HXQ, HXU, HX2, HX26, HX4, LD, LDB1, LDB2, LDN, LD4, LH, LHB2, LHP1, LHQ4, LJ, LJC1, LJG, LSJ, LVL, LX, LX2, LX4, NAX, NAX1, NDF1, NDJ, NJ, NJC1, NJG, NMB, NTB, NTU, NW, NWA, NWB2, NX, PMX, PX, PXU, PX2, QA, QAB2, QA2, QD, QG, QG2, QH, QHP1, QHQ4, QH26, QH4, QJF, QJF1, QM, QSW4, QT, QTP, QTP2, QVL, QX, QXB2, QXC, QXC9, QXE, QXE2, QXE4, QXE6, QXE8, QXF, QXF2, QXH4, QXQ, QXS2, QXU, QX2, QX26, QX4, QX7, RG, RH, RHA2, RHQ4, RH2, RH26, RMG2, RX, RXU, RX2, RX4, SD, SDB1, SDB2, SDN, SD4, SH, SHQ4, SJ, SJG, SMC4, SM11, SM12, SM14, SM21, SM22, SM24, SWG4, SX, SXE4, SXU, SX4, SX7, TX, TXE, TXU, TXU1, TX2, TX4, UX, VA2, VEE1, VEN1, VES1, VGG2, VMG1, VNG4, VSD, VSD7, VX, VXU, VXU1, VX2, VX4
	16024-ZH7-A20	1	-	1	-----	SMG1, SMG2

Ref. No.	Part No.	Description	Reqd. QTY			Serial No.	Parts catalogue code
			(1)	GX200 (2)	(3)		
8	16028-ZE0-005	SCREW SET	1	-	-	-----	BL, HX, HXQ, HXU, HX2, HX26, HX4, LD, LDB1, LDB2, LDN, LD4, LH, LHB2, LHP1, LHQ4, LJ, LJC1, LJG, LSJ, LVL, LX, LX2, LX4, NAX, NAX1, NDF1, NDJ, NJ, NJC1, NJG, NMB, NTB, NTU, NW, NWA, NWB2, NX, PMX, PX, PXU, PX2, QA, QAB2, QA2, QD, QG, QG2, QH, QHP1, QHQ4, QH26, QH4, QJF, QJF1, QM, QSW4, QT, QTP, QTP2, QVL, QX, QXB2, QXC, QXC9, QXE, QXE2, QXE4, QXE6, QXE8, QXF, QXF2, QXH4, QXQ, QXS2, QXU, QX2, QX26, QX4, QX7, RG, RH, RHA2, RHQ4, RH2, RH26, RMG2, RX, RXU, RX2, RX4, SD, SDB1, SDB2, SDN, SD4, SH, SHQ4, SJ, SJG, SMC4, SMG1, SMG2, SM11, SM12, SM14, SM21, SM22, SM24, SWG4, SX, SXE4, SXU, SX4, SX7, TX, TXE, TXU, TXU1, TX2, TX4, UX, VA2, VEE1, VEN1, VES1, VGG2, VMG1, VNG4, VSD, VSD7, VX, VXU, VXU1, VX2, VX4
9	16044-ZE0-005	CHOKE SET	1	-	1	-----	BL, HX, HXQ, HXU, HX2, HX26, HX4, LD, LDB1, LDB2, LDN, LD4, LH, LHB2, LHP1, LHQ4, LJ, LJC1, LJG, LSJ, LVL, LX, LX2, LX4, NAX, NAX1, NDF1, NDJ, NJ, NJC1, NJG, NMB, NTB, NTU, NW, NWA, NWB2, NX, PMX, PX, PXU, PX2, QA, QAB2, QA2, QD, QG, QG2, QH, QHP1, QHQ4, QH26, QH4, QJF, QJF1, QM, QSW4, QT, QTP, QTP2, QVL, QX, QXB2, QXC, QXC9, QXE, QXE2, QXE4, QXE6, QXE8, QXF, QXF2, QXH4, QXQ, QXS2, QXU, QX2, QX26, QX4, QX7, RG, RH, RHA2, RHQ4, RH2, RH26, RMG2, RX, RXU, RX2, RX4, SD, SDB1, SDB2, SDN, SD4, SH, SHQ4, SJ, SJG, SMC4, SMG1, SMG2, SM11, SM12, SM14, SM21, SM22, SM24, SWG4, SX, SXE4, SXU, SX4, SX7, TX, TXE, TXU, TXU1, TX2, TX4, UX, VA2, VEE1, VEN1, VES1, VGG2, VMG1, VNG4, VSD, VSD7, VX, VXU, VXU1, VX2, VX4
10	16100-ZLO-000	CARBURETOR ASSY. (BE64A A) ..	1	-	-	-----	1030012 QXF
			1	-	-	-----	1030031 HX, HX4, LH, LHB2, LHQ4, LX, LX4, NX, PX, QH, QHQ4, QX, QXE, QXE4, QX4, RH, RHQ4, RX, RX4, SH, SHQ4, SMC4, SX, SX4, TX, TXE, TX4, UX, VSD, VX, VXU, VX4
	16100-ZLO-005	CARBURETOR ASSY. (BE64A B) ..	1	-	-	-----	QG, RG
			1	-	-	-----	1030013 QXF
			1	-	-	-----	1030032 QXE, TX4, UX
			1	-	-	-----	1122110 HXU, LHP1, PMX, PXU, QHP1, QSW4, QTP, QXU, RXU, SXE4, SXU, TXU, TXU1, VNG4, VXU1
			1	-	-	-----	1267448 NDF1, NDJ, SM14, SM21, SM24, VMG1
			1	-	-	-----	1030032 1122110 HX, HX4, LH, LHB2, LHQ4, LX, LX4, NX, PX, QH, QHQ4, QX, QXE4, QX4, RH, RHQ4, RX, RX4, SH, SHQ4, SMC4, SX, SX4, TX, TXE, VSD, VX, VXU, VX4
	16100-ZLO-810	CARBURETOR ASSY. (BE69A A) ..	1	-	-	-----	1030319 LD, LDB1, LDB2, LD4, QD, QM, SD, SDB1, SDB2, SD4
	16100-ZLO-811	CARBURETOR ASSY. (BE69A B) ..	1	-	-	-----	1030320 LD, LDB1, LDB2, LD4, QD, QM, SD, SDB1, SDB2, SD4
	16100-ZLO-800	CARBURETOR ASSY. (BE64G A) ..	1	-	-	-----	1033598 QXC
	16100-ZLO-801	CARBURETOR ASSY. (BE64G B) ..	1	-	-	-----	1033599 1122110 QXC
	16100-ZLO-820	CARBURETOR ASSY. (BE64C A) ..	1	-	-	-----	1030012 LJ, LJG, LSJ, NAX, NAX1, NJ, NJG, NMB, NTB, QA, QAB2, QT, SJ, SJG
	16100-ZLO-821	CARBURETOR ASSY. (BE64C B) ..	1	-	-	-----	LDN, LJC1, NTU, NW, NWA, NWB2, QJF, SDN
			1	-	-	-----	1030013 LJ, LJG, LSJ, NAX, NAX1, NJ, NJG, NMB, NTB, QA, QT, SJ, SJG
			1	-	-	-----	1113369 VEE1
			1	-	-	-----	1692611 QJF1
			1	-	-	-----	1863015 NJC1
			1	-	-	-----	1030013 1122110 QAB2
	16100-ZKO-V01	CARBURETOR ASSY. (BE64U A) ..	1	-	1	-----	1692612 QJF1
			1	-	-	-----	1863016 NJC1
	16100-ZLO-S71	CARBURETOR ASSY. (BE64T A) ..	1	-	-	-----	SMG2
	16100-ZLO-U21	CARBURETOR ASSY. (BE64N A) ..	1	-	-	-----	VGG2
	16100-ZLO-V20	CARBURETOR ASSY. (BE64F A) ..	1	-	-	-----	1035184 QXC9
	16100-ZLO-V21	CARBURETOR ASSY. (BE64F B) ..	1	-	-	-----	QH4, QTP2, QXH4
			1	-	-	-----	1035185 QXC9
			1	-	-	-----	1122111 QXC
	16100-ZLO-W00	CARBURETOR ASSY. (BE64D A) ..	1	-	-	-----	1030012 HXQ, QXQ
	16100-ZLO-W01	CARBURETOR ASSY. (BE64D B) ..	1	-	-	-----	1030013 HXQ, QXQ
	16100-ZLO-W11	CARBURETOR ASSY. (BE64R A) ..	1	-	-	-----	1299202 SMG1
	16100-ZLO-W12	CARBURETOR ASSY. (BE64R B) ..	1	-	-	-----	1299203 SMG1
	16100-ZLO-W50	CARBURETOR ASSY. (BE64B A) ..	1	-	-	-----	1030071 HX2, HX26, LX2, PX2, QH26, QXE2, QXE6, QXF2, QXS2, QX2, QX26, RHA2, RH2, RH26, TX2, VA2, VX2



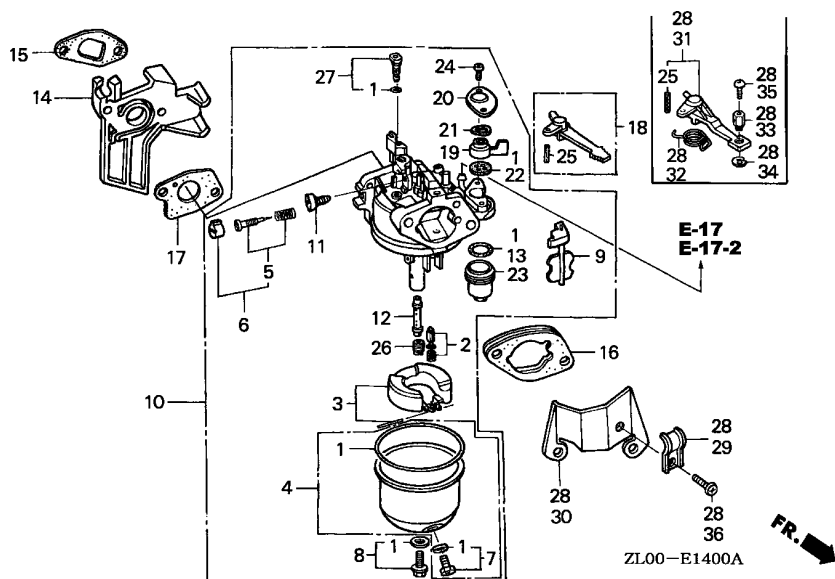

Ref. No.	Part No.	Description	Reqd. QTY			Serial No.	Parts catalogue code	
			(1)	(2)	(3)			
10)	16100-ZL0-W51	CARBURETOR ASSY. (BE64B B) ..	1	-	-	-----	QG2,QXB2,QXE8,QX7,RMG2,RX2,SM11,SM12,SM22,SWG4,SX7,VEN1,VES1,VSD7	
			1	-	-	1030072	-----	HX2,HX26,LX2,PX2,QH26,QXE2,QXE6,QXF2,QXS2,QX2,QX26,RHA2,RH2,RH26
			1	-	-	1113370	-----	TX2,VA2,VX2
			1	-	-	1122111	-----	VEE1
			1	-	-	1122111	-----	HX,HXU,HX4,LH,LHB2,LHP1,LHQ4,LX,LX4,NX,PMX,PX,PXU,QH,QHP1,QHQ4
			1	-	-	1122111	-----	QSW4,QTP,QX,QXE4,QXU,QX4,RH,RHQ4,RX,RXU,RX4,SH,SHQ4,SMC4,SX,SXE4
			1	-	-	1122111	-----	SXU,SX4,TX,TXE,TXU,TXU1,VNG4,VSD,VX,VXU,VXU1,VX4
			1	-	-	1267449	-----	NDF1,SM14,SM21,SM24,VMG1
			1	-	-	1267449	1907885	NDJ
	16100-ZL0-W60	CARBURETOR ASSY. (BE64E A) ..	1	-	-	-----	1030012	QA2
	16100-ZL0-W61	CARBURETOR ASSY. (BE64E B) ..	1	-	-	1030013	-----	QA2
			1	-	-	1122111	-----	QAB2
			1	-	-	1907886	-----	NDJ
	16100-ZL0-W81	CARBURETOR ASSY. (BE64S A) ..	1	-	-	-----	-----	BL,LVL,QVL
11	16124-ZE0-005	SCREW, THROTTLE STOP	1	-	-	-----	-----	BL,HX,HXQ,HXU,HX2,HX26,HX4,LD,LDB1,LDB2,LDN,LD4,LH,LHB2,LHP1,LHQ4
								LJ,LJC1,LJG,LSJ,LVL,LX,LX2,LX4,NAX,NAX1,NDF1,NDJ,NJ,NJC1,NJG,NMB
								NTB,NTU,NW,NWA,NWB2,NX,PMX,PX,PXU,PX2,QA,QAB2,QA2,QD,QG,QG2,QH
								QHP1,QHQ4,QH26,QH4,QJF,QJF1,QM,QSW4,QT,QTP,QTP2,QVL,QX,QXB2,QXC
								QXC9,QXE,QXE2,QXE4,QXE6,QXE8,QXF,QXF2,QXH4,QXQ,QXS2,QXU,QX2,QX26
								QX4,QX7,RG,RH,RHA2,RHQ4,RH2,RH26,RMG2,RX,RXU,RX2,RX4,SD,SDB1,SDB2
								SDN,SD4,SH,SHQ4,SJ,SJG,SMC4,SMG1,SMG2,SM11,SM12,SM14,SM21,SM22
								SM24,SWG4,SX,SXE4,SXU,SX4,SX7,TX,TXE,TXU,TXU1,TX2,TX4,UX,VA2,VEE1
								VEN1,VES1,VGG2,VMG1,VNG4,VSD,VSD7,VX,VXU,VXU1,VX2,VX4
			-	-	1	-----	-----	
12	16166-ZL0-W00	NOZZLE, MAIN	1	-	-	-----	-----	HXQ,QXQ

Ref. No.	Part No.	Description	Reqd. QTY			Serial No.	Parts catalogue code
			(1)	GX200 (2)	(3)		
12)	16166-ZL0-000	NOZZLE, MAIN	1	-	-	-----	BL, HX, HXU, HX2, HX26, HX4, LD, LDB1, LDB2, LDN, LD4, LH, LHB2, LHP1, LHQ4, LJ, LJC1, LJG, LSJ, LVL, LX, LX2, LX4, NAX, NAX1, NDF1, NDJ, NJ, NJC1, NJG, NMB, NTB, NTU, NW, NWA, NWB2, NX, PMX, PX, PXU, PX2, QA, QAB2, QA2, QD, QG, QG2, QH, QHP1, QHQ4, QH26, QJF, QJF1, QM, QSW4, QT, QTP, QVL, QX, QXB2, QXE, QXE2, QXE4, QXE6, QXE8, QXF, QXF2, QXS2, QXU, QX2, QX26, QX4, QX7, RG, RH, RHA2, RHQ4, RH2, RH26, RMG2, RX, RXU, RX2, RX4, SD, SDB1, SDB2, SDN, SD4, SH, SHQ4, SJ, SJG, SMC4, SMG1, SMG2, SM11, SM12, SM14, SM21, SM22, SM24, SWG4, SX, SXE4, SXU, SX4, SX7, TX, TXE, TXU, TXU1, TX2, TX4, UX, VA2, VEE1, VEN1, VES1, VGG2, VMG1, VNG4, VSD, VSD7, VX, VXU, VXU1, VX2, VX4
	16166-ZL0-V20	-	-	1	-----	QH4, QTP2, QXC, QXC9, QXH4
13	16173-001-004	PACKING, FUEL STRAINER CUP ..	1	-	-	-----	BL, HX, HXQ, HXU, HX2, HX26, HX4, LDN, LH, LHB2, LHP1, LHQ4, LJ, LJC1, LJG, LSJ, LVL, LX, LX2, LX4, NAX, NAX1, NDF1, NDJ, NJ, NJC1, NJG, NMB, NTB, NTU, NW, NWA, NWB2, NX, PMX, PX, PXU, PX2, QA, QAB2, QA2, QG, QG2, QH, QHP1, QHQ4, QH26, QH4, QJF, QJF1, QSW4, QT, QTP, QTP2, QVL, QX, QXB2, QXC, QXC9, QXE, QXE2, QXE4, QXE6, QXE8, QXF, QXF2, QXH4, QXQ, QXS2, QXU, QX2, QX26, QX4, QX7, RG, RH, RHA2, RHQ4, RH2, RH26, RMG2, RX, RXU, RX2, RX4, SDN, SH, SHQ4, SJ, SJG, SMC4, SMG1, SMG2, SM11, SM12, SM14, SM21, SM22, SM24, SWG4, SX, SXE4, SXU, SX4, SX7, TX, TXE, TXU, TXU1, TX2, TX4, UX, VA2, VEE1, VEN1, VES1, VGG2, VMG1, VNG4, VSD, VSD7, VX, VXU, VXU1, VX2, VX4
14	16211-ZL0-000	INSULATOR, CARBURETOR	1	-	-	-----	BL, HX, HXQ, HXU, HX2, HX26, HX4, LD, LDB1, LDB2, LDN, LD4, LH, LHB2, LHP1, LHQ4, LJ, LJC1, LJG, LSJ, LVL, LX, LX2, LX4, NAX, NAX1, NDF1, NDJ, NJ, NJC1, NJG, NMB, NTB, NTU, NW, NWA, NWB2, NX, PMX, PX, PXU, PX2, QA, QAB2, QA2, QD, QG, QG2, QH, QHP1, QHQ4, QH26, QH4, QJF, QJF1, QM, QSW4, QT, QTP, QTP2, QVL, QX, QXB2, QXC, QXC9, QXE, QXE2, QXE4, QXE6, QXE8, QXF, QXF2, QXH4, QXQ, QXS2, QXU, QX2, QX26, QX4, QX7, RG, RH, RHA2, RHQ4, RH2, RH26, RMG2, RX, RXU, RX2, RX4, SD, SDB1, SDB2, SDN, SD4, SH, SHQ4, SJ, SJG, SMC4, SMG1, SMG2, SM11, SM12, SM14, SM21, SM22, SM24, SWG4, SX, SXE4, SXU, SX4, SX7, TX, TXE, TXU, TXU1, TX2, TX4, UX, VA2, VEE1, VEN1, VES1, VGG2, VMG1, VNG4, VSD, VSD7, VX, VXU, VXU1, VX2, VX4
15	16212-ZH8-800	PACKING, INSULATOR	1	-	-	-----	BL, HX, HXQ, HXU, HX2, HX26, HX4, LD, LDB1, LDB2, LDN, LD4, LH, LHB2, LHP1, LHQ4, LJ, LJC1, LJG, LSJ, LVL, LX, LX2, LX4, NAX, NAX1, NDF1, NDJ, NJ, NJC1, NJG, NMB, NTB, NTU, NW, NWA, NWB2, NX, PMX, PX, PXU, PX2, QA, QAB2, QA2, QD, QG, QG2, QH, QHP1, QHQ4, QH26, QH4, QJF, QJF1, QM, QSW4, QT, QTP, QTP2, QVL, QX, QXB2, QXC, QXC9, QXE, QXE2, QXE4, QXE6, QXE8, QXF, QXF2, QXH4, QXQ, QXS2, QXU, QX2, QX26, QX4, QX7, RG, RH, RHA2, RHQ4, RH2, RH26, RMG2, RX, RXU, RX2, RX4, SD, SDB1, SDB2, SDN, SD4, SH, SHQ4, SJ, SJG, SMC4, SMG1, SMG2, SM11, SM12, SM14, SM21, SM22, SM24, SWG4, SX, SXE4, SXU, SX4, SX7, TX, TXE, TXU, TXU1, TX2, TX4, UX, VA2, VEE1, VEN1, VES1, VGG2, VMG1, VNG4, VSD, VSD7, VX, VXU, VXU1, VX2, VX4
16	16220-ZE1-020	SPACER COMP., CARBURETOR	1	-	-	-----	BL, HX, HXQ, HXU, HX2, HX26, HX4, LD, LDB1, LDB2, LDN, LD4, LH, LHB2, LHP1, LHQ4, LJ, LJC1, LJG, LSJ, LVL, LX, LX2, LX4, NAX, NAX1, NDF1, NDJ, NJ, NJC1, NJG, NMB, NTB, NTU, NW, NWA, NWB2, NX, PMX, PX, PXU, PX2, QA, QAB2, QA2, QD, QG, QG2, QH, QHP1, QHQ4, QH26, QH4, QJF, QJF1, QM, QSW4, QT, QTP, QTP2, QVL, QX, QXB2, QXC, QXC9, QXE, QXE2, QXE4, QXE6, QXE8, QXF, QXF2, QXH4, QXQ, QXS2, QXU, QX2, QX26, QX4, QX7, RG, RH, RHA2, RHQ4, RH2, RH26, RMG2, RX, RXU, RX2, RX4, SD, SDB1, SDB2, SDN, SD4, SH, SHQ4, SJ, SJG, SMC4, SMG1, SMG2, SM11, SM12, SM14, SM21, SM22, SM24, SWG4, SX, SXE4, SXU, SX4, SX7, TX, TXE, TXU, TXU1, TX2, TX4, UX, VA2, VEE1, VEN1, VES1, VGG2, VMG1, VNG4, VSD, VSD7, VX, VXU, VXU1, VX2, VX4
	16220-ZE1-004	-	-	1	-----	



E-14

CARBURETOR(1)

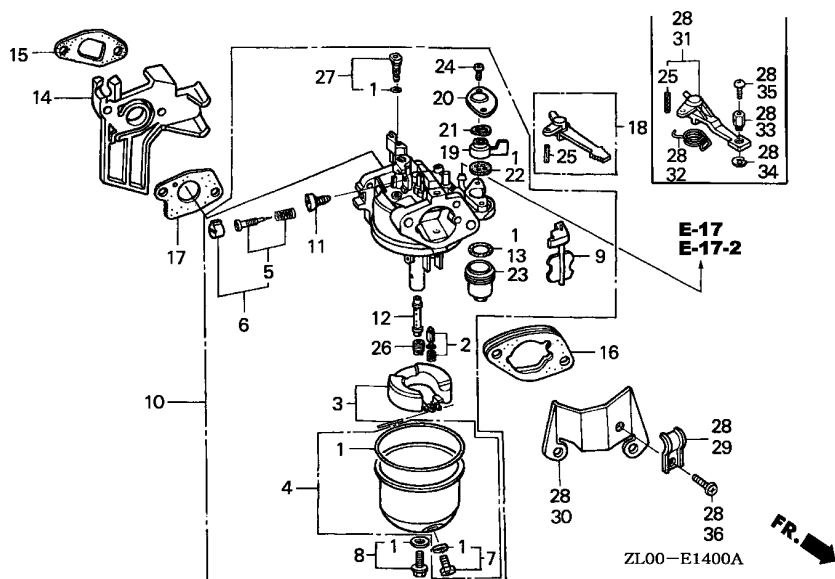

Ref. No.	Part No.	Description	Reqd. QTY			Serial No.	Parts catalogue code
			(1)	GX200 (2)	(3)		
17	16221-ZH8-801	PACKING, CARBURETOR	1	-	-	-----	BL, HX, HXQ, HXU, HX2, HX26, HX4, LD, LDB1, LDB2, LDN, LD4, LH, LHB2, LHP1, LHQ4, LJ, LJC1, LJG, LSJ, LVL, LX, LX2, LX4, NAX, NAX1, NDF1, NDJ, NJ, NJC1, NJG, NMB, NTB, NTU, NW, NWA, NWB2, NX, PMX, PX, PXU, PX2, QA, QAB2, QA2, QD, QG, QG2, QH, QHP1, QHQ4, QH26, QH4, QJF, QJF1, QM, QSW4, QT, QTP, QTP2, QVL, QX, QXB2, QXC, QXC9, QXE, QXE2, QXE4, QXE6, QXE8, QXF, QXF2, QXH4, QXQ, QXS2, QXU, QX2, QX26, QX4, QX7, RG, RH, RHA2, RHQ4, RH2, RH26, RMG2, RX, RXU, RX2, RX4, SD, SDB1, SDB2, SDN, SD4, SH, SHQ4, SJ, SJG, SMC4, SMG1, SMG2, SM11, SM12, SM14, SM21, SM22, SM24, SWG4, SX, SXE4, SXU, SX4, SX7, TX, TXE, TXU, TXU1, TX2, TX4, UX, VA2, VEE1, VEN1, VES1, VGG2, VMG1, VNG4, VSD, VSD7, VX, VXU, VXU1, VX2, VX4
18	16610-ZE1-000	LEVER COMP., CHOKE (STD.) ...	1	-	1	-----	BL, HX, HXQ, HXU, HX2, HX26, HX4, LD, LDB1, LDB2, LDN, LD4, LH, LHB2, LHP1, LHQ4, LJ, LJC1, LJG, LSJ, LVL, LX, LX2, LX4, NDF1, NDJ, NJ, NJG, NW, NWA, NWB2, NX, PMX, PX, PXU, PX2, QA, QAB2, QA2, QD, QG, QG2, QH, QHP1, QHQ4, QH26, QJF, QM, QT, QTP, QVL, QX, QXB2, QXC, QXC9, QXE, QXE2, QXE4, QXE6, QXE8, QXF, QXF2, QXQ, QXS2, QXU, QX2, QX26, QX4, QX7, RG, RH, RHA2, RHQ4, RH2, RH26, RMG2, RX, RXU, RX2, RX4, SD, SDB1, SDB2, SDN, SD4, SH, SHQ4, SJ, SJG, SMC4, SM11, SM12, SM14, SM21, SM22, SM24, SX, SXE4, SXU, SX4, SX7, TX, TXE, TXU, TXU1, TX2, TX4, UX, VA2, VEE1, VEN1, VES1, VGG2, VMG1, VNG4, VSD, VSD7, VX, VXU, VXU1, VX2, VX4

2

Ref. No.	Part No.	Description	Reqd. QTY			Serial No.	Parts catalogue code
			(1)	GX200 (2)	(3)		
19	16953-ZE1-811	LEVER, COCK	1	-	-	-----	HX, HXU, HX26, HX4, LD, LDB1, LDB2, LD4, LH, LHB2, LHQ4, LJ, LJG, LSJ, LX, LX4, NAX, NAX1, NJ, NJG, NTB, NX, PX, PXU, QAB2, QD, QH, QHQ4, QH26, QM, QT, QX, QXC, QXE, QXE4, QXE6, QXU, QX26, QX4, RH, RHQ4, RH26, RX, RXU, RX4, SD, SDB1, SDB2, SD4, SH, SHQ4, SJ, SJG, SMC4, SMG1, SX, SXU, SX4, TX, TXE, TXU, TXU1, TX4, UX, VSD, VX, VXU, VXU1, VX4
		(CARBURETOR NO.)	1	-	-	-----	BE64A A QXF
		//	1	-	-	-----	BE64B A HX2, LX2, PX2, QXE2, QXF2, QXS2, QX2, RHA2, RH2, TX2, VA2, VX2
		//	1	-	-	-----	BE64C A QA
		//	1	-	-	-----	BE64D A HXQ, QXQ
		//	1	-	-	-----	BE64E A QA2
		//	1	-	-	-----	BE64F A QXC9
	16953-ZE1-812	1	-	-	-----	BL, LDN, LHP1, LJC1, LVL, NDF1, NDJ, NJC1, NMB, NTU, NW, NWA, NWB2, PMX, QG, QG2, QHP1, QH4, QJF, QJF1, QSW4, QTP, QTP2, QVL, QXB2, QXE8, QXH4, QX7, RG, RMG2, RX2, SDN, SMG2, SM11, SM12, SM14, SM21, SM22, SM24, SWG4, SXE4, SX7, VEE1, VEN1, VES1, VGG2, VMG1, VNG4, VSD7
		(CARBURETOR NO.)	1	-	-	-----	QXF
		//	1	-	-	-----	BE64B B ----- HX2, LX2, PX2, QXE2, QXF2, QXS2, QX2, RHA2, RH2, TX2, VA2, VX2
		//	1	-	-	-----	BE64C B ----- QA
		//	1	-	-	-----	BE64D B ----- HXQ, QXQ
		//	1	-	-	-----	BE64E B ----- QA2
		//	1	-	-	-----	BE64F B ----- QXC9
		//	-	-	1		
20	16954-ZE1-811	PLATE, LEVER SETTING	1	-	-	-----	LSJ, NAX, NAX1
		(CARBURETOR NO.)	1	-	-	-----	BE64A A HX, HX4, LH, LHB2, LHQ4, LX, LX4, NX, PX, QH, QHQ4, QX, QXE, QXE4, QXF, QX4, RH, RHQ4, RX, RX4, SH, SHQ4, SMC4, SX, SX4, TX, TXE, TX4, UX, VSD, VX, VXU, VX4
		//	1	-	-	-----	BE64B A HX2, HX26, LX2, PX2, QH26, QXE2, QXE6, QXF2, QXS2, QX2, QX26, RHA2, RH2, RH26, TX2, VA2, VX2
		//	1	-	-	-----	BE64C A LJ, LJG, NJ, NJG, NMB, NTB, QA, QAB2, QT, SJ, SJG
		//	1	-	-	-----	BE64E A QA2
		//	1	-	-	-----	BE69A A LD, LDB1, LDB2, LD4, QD, QM, SD, SDB1, SDB2, SD4
	16954-ZE1-812	1	-	-	-----	BL, HXU, LDN, LHP1, LJC1, LVL, NDF1, NDJ, NJC1, NTU, NW, NWA, NWB2, PMX, PXU, QG, QG2, QHP1, QH4, QJF, QJF1, QSW4, QTP, QTP2, QVL, QXB2, QXE8, QXH4, QXU, QX7, RG, RMG2, RXU, RX2, SDN, SMG1, SMG2, SM11, SM12, SM14, SM21, SM22, SM24, SWG4, SXE4, SXU, SX7, TXU, TXU1, VEE1, VEN1, VES1, VGG2, VMG1, VNG4, VSD7, VXU1
		(CARBURETOR NO.)	1	-	-	-----	BE64A B ----- HX, HX4, LH, LHB2, LHQ4, LX, LX4, NX, PX, QH, QHQ4, QX, QXE, QXE4, QXF, QX4, RH, RHQ4, RX, RX4, SH, SHQ4, SMC4, SX, SX4, TX, TXE, TX4, UX, VSD, VX, VXU, VX4
		//	1	-	-	-----	BE64B B ----- HX2, HX26, LX2, PX2, QH26, QXE2, QXE6, QXF2, QXS2, QX2, QX26, RHA2, RH2, RH26, TX2, VA2, VX2
		//	1	-	-	-----	BE64C B ----- LJ, LJG, NJ, NJG, NMB, NTB, QA, QAB2, QT, SJ, SJG
		//	1	-	-	-----	BE64D B ----- HXQ, QXQ
		//	1	-	-	-----	BE64E B ----- QA2
		//	1	-	-	-----	BE64F B ----- QXC9
		//	1	-	-	-----	BE64G B ----- QXC
		//	1	-	-	-----	BE69A B ----- LD, LDB1, LDB2, LD4, QD, QM, SD, SDB1, SDB2, SD4
		//	-	-	1		
	16954-ZF0-841	1	-	-	-----	BE64D A HXQ, QXQ
		(CARBURETOR NO.)	1	-	-	-----	BE64F A QXC9
		//	1	-	-	-----	BE64G A QXC
		//	1	-	-	-----	



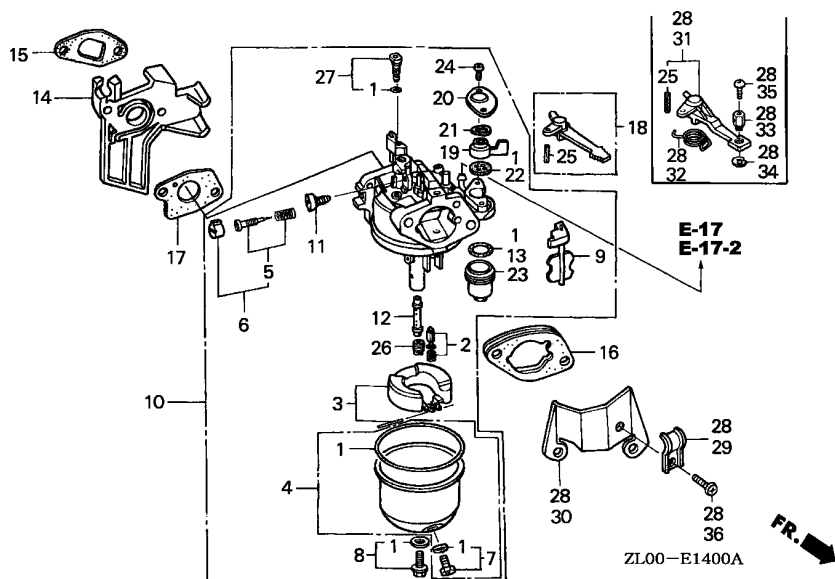

Ref. No.	Part No.	Description	Reqd. QTY			Serial No.	Parts catalogue code
			(1)	GX200 (2)	(3)		
21	16956-ZE1-811	SPRING, COCK LEVER	1	-	-	-----	BL, HX, HXQ, HXU, HX2, HX26, HX4, LD, LDB1, LDB2, LDN, LD4, LH, LHB2, LHP1, LHQ4, LJ, LJC1, LJG, LSJ, LVL, LX, LX2, LX4, NAX, NAX1, NDF1, NDJ, NJ, NJC1, NJG, NMB, NTB, NTU, NW, NWA, NWB2, NX, PMX, PX, PXU, PX2, QA, QAB2, QA2, QD, QG, QG2, QH, QHP1, QHQ4, QH26, QH4, QJF, QJF1, QM, QSW4, QT, QTP, QTP2, QVL, QX, QXB2, QXC, QXC9, QXE, QXE2, QXE4, QXE6, QXE8, QXF, QXF2, QXH4, QXQ, QXS2, QXU, QX2, QX26, QX4, QX7, RG, RH, RHA2, RHQ4, RH2, RH26, RMG2, RX, RXU, RX2, RX4, SD, SDB1, SDB2, SDN, SD4, SH, SHQ4, SJ, SJG, SMC4, SMG1, SMG2, SM11, SM12, SM14, SM21, SM22, SM24, SWG4, SX, SXE4, SXU, SX4, SX7, TX, TXE, TXU, TXU1, TX2, TX4, UX, VA2, VEE1, VEN1, VES1, VGG2, VMG1, VNG4, VSD, VSD7, VX, VXU, VXU1, VX2, VX4
22	16957-ZE1-812	PACKING, FUEL COCK	1	-	1	-----	BL, HX, HXQ, HXU, HX2, HX26, HX4, LD, LDB1, LDB2, LDN, LD4, LH, LHB2, LHP1, LHQ4, LJ, LJC1, LJG, LSJ, LVL, LX, LX2, LX4, NAX, NAX1, NDF1, NDJ, NJ, NJC1, NJG, NMB, NTB, NTU, NW, NWA, NWB2, NX, PMX, PX, PXU, PX2, QA, QAB2, QA2, QD, QG, QG2, QH, QHP1, QHQ4, QH26, QH4, QJF, QJF1, QM, QSW4, QT, QTP, QTP2, QVL, QX, QXB2, QXC, QXC9, QXE, QXE2, QXE4, QXE6, QXE8, QXF, QXF2, QXH4, QXQ, QXS2, QXU, QX2, QX26, QX4, QX7, RG, RH, RHA2, RHQ4, RH2, RH26, RMG2, RX, RXU, RX2, RX4, SD, SDB1, SDB2, SDN, SD4, SH, SHQ4, SJ, SJG, SMC4, SMG1, SMG2, SM11, SM12, SM14, SM21, SM22, SM24, SWG4, SX, SXE4, SXU, SX4, SX7, TX, TXE, TXU, TXU1, TX2, TX4, UX, VA2, VEE1, VEN1, VES1, VGG2, VMG1, VNG4, VSD, VSD7, VX, VXU, VXU1, VX2, VX4

Ref. No.	Part No.	Description	Reqd. QTY			Serial No.	Parts catalogue code
			(1)	GX200 (2)	(3)		
23	16967-ZE0-811	CUP, FUEL STRAINER	1	-	-	-----	BL, HX, HXQ, HXU, HX2, HX26, HX4, LDN, LH, LHB2, LHP1, LHQ4, LJ, LJC1, LJG, LSJ, LVL, LX, LX2, LX4, NAX, NAX1, NDF1, NDJ, NJ, NJC1, NJG, NMB, NTB, NTU, NW, NWA, NWB2, NX, PMX, PX, PXU, PX2, QA, QAB2, QA2, QG, QG2, QH, QHP1, QHQ4, QH26, QH4, QJF, QJF1, QSW4, QT, QTP, QTP2, QVL, QX, QXB2, QXC, QXC9, QXE, QXE2, QXE4, QXE6, QXE8, QXF, QXF2, QXH4, QXQ, QXS2, QXU, QX2, QX26, QX4, QX7, RG, RH, RHA2, RHQ4, RH2, RH26, RMG2, RX, RXU, RX2, RX4, SDN, SH, SHQ4, SJ, SJG, SMC4, SMG1, SMG2, SM11, SM12, SM14, SM21, SM22, SM24, SWG4, SX, SXE4, SXU, SX4, SX7, TX, TXE, TXU, TXU1, TX2, TX4, UX, VA2, VEE1, VEN1, VES1, VGG2, VMG1, VNG4, VSD, VSD7, VX, VXU, VXU1, VX2, VX4
			-	-	1		
24	93500-03008-1G	SCREW, PAN, 3X8	2	-	-	-----	BE64A A HX, HX4, LH, LHB2, LHQ4, LX, LX4, NX, PX, QH, QHQ4, QX, QXE, QXE4, QXF, QX4, RH, RHQ4, RX, RX4, SH, SHQ4, SMC4, SX, SX4, TX, TXE, TX4, UX, VSD, VX, VXU, VX4
		(CARBURETOR NO.)	2	-	-	-----	BE64B A HX2, HX26, LX2, PX2, QH26, QXE2, QXE6, QXF2, QXS2, QX2, QX26, RHA2, RH2, RH26, TX2, VA2, VX2
		//	2	-	-	-----	BE64C A LJ, LJG, LSJ, NAX, NAX1, NJ, NJG, NMB, NTB, QA, QAB2, QT, SJ, SJG
		//	2	-	-	-----	BE64D A HXQ, QXQ
		//	2	-	-	-----	BE64E A QA2
		//	2	-	-	-----	BE64F A QXC9
		//	2	-	-	-----	BE64G A QXC
		//	2	-	-	-----	BE69A A LD, LDB1, LDB2, LD4, QD, QM, SD, SDB1, SDB2, SD4
	93500-03006-1H	SCREW, PAN, 3X6	2	-	-	-----	BL, HXU, LDN, LHP1, LJC1, LVL, NDF1, NDJ, NJC1, NTU, NW, NWA, NWB2, PMX, PXU, QG, QG2, QHP1, QH4, QJF, QJF1, QSW4, QTP, QTP2, QVL, QXB2, QXE8, QXH4, QXU, QX7, RG, RMG2, RXU, RX2, SDN, SMG1, SMG2, SM11, SM12, SM14, SM21, SM22, SM24, SWG4, SXE4, SXU, SX7, TXU, TXU1, VEE1, VEN1, VES1, VGG2, VMG1, VNG4, VSD7, VXU1
		(CARBURETOR NO.)	2	-	-	-----	BE64A B HX, HX4, LH, LHB2, LHQ4, LX, LX4, NX, PX, QH, QHQ4, QX, QXE, QXE4, QXF, QX4, RH, RHQ4, RX, RX4, SH, SHQ4, SMC4, SX, SX4, TX, TXE, TX4, UX, VSD, VX, VXU, VX4
		//	2	-	-	-----	BE64B B HX2, HX26, LX2, PX2, QH26, QXE2, QXE6, QXF2, QXS2, QX2, QX26, RHA2, RH2, RH26, TX2, VA2, VX2
		//	2	-	-	-----	BE64C B LJ, LJG, LSJ, NAX, NAX1, NJ, NJG, NMB, NTB, QA, QAB2, QT, SJ, SJG
		//	2	-	-	-----	BE64D B HXQ, QXQ
		//	2	-	-	-----	BE64E B QA2
		//	2	-	-	-----	BE64F B QXC9
		//	2	-	-	-----	BE64G B QXC
		//	2	-	-	-----	BE69A B LD, LDB1, LDB2, LD4, QD, QM, SD, SDB1, SDB2, SD4
			-	-	2		
25	94305-20122	PIN, SPRING, 2X12	1	-	-	-----	BL, HX, HXQ, HXU, HX2, HX26, HX4, LD, LDB1, LDB2, LDN, LD4, LH, LHB2, LHP1, LHQ4, LJ, LJC1, LJG, LSJ, LVL, LX, LX2, LX4, NAX, NAX1, NDF1, NDJ, NJ, NJC1, NJG, NMB, NTB, NTU, NW, NWA, NWB2, NX, PMX, PX, PXU, PX2, QA, QAB2, QA2, QD, QG, QG2, QH, QHP1, QHQ4, QH26, QH4, QJF, QJF1, QM, QSW4, QT, QTP, QTP2, QVL, QX, QXB2, QXC, QXC9, QXE, QXE2, QXE4, QXE6, QXE8, QXF, QXF2, QXH4, QXQ, QXS2, QXU, QX2, QX26, QX4, QX7, RG, RH, RHA2, RHQ4, RH2, RH26, RMG2, RX, RXU, RX2, RX4, SD, SDB1, SDB2, SDN, SD4, SH, SHQ4, SJ, SJG, SMC4, SMG1, SMG2, SM11, SM12, SM14, SM21, SM22, SM24, SWG4, SX, SXE4, SXU, SX4, SX7, TX, TXE, TXU, TXU1, TX2, TX4, UX, VA2, VEE1, VEN1, VES1, VGG2, VMG1, VNG4, VSD, VSD7, VX, VXU, VXU1, VX2, VX4
			-	-	1		
26	99101-ZH7-0680	JET, MAIN, #68	(1)	-	-	-----	BE64A A QXE, QXF, TX4, UX
	99101-ZH7-0700	JET, MAIN, #70	(1)	-	-	-----	BE64A A QXE, QXF, TX4, UX
	99101-ZH7-0720	JET, MAIN, #72	1	-	-	-----	BE64A A QXE, QXF, TX4, UX
	99101-ZH7-0700	JET, MAIN, #70	(1)	-	-	-----	BE64C A QA
		(CARBURETOR NO.)	(1)	-	-	-----	BE69A A LD4
		//					



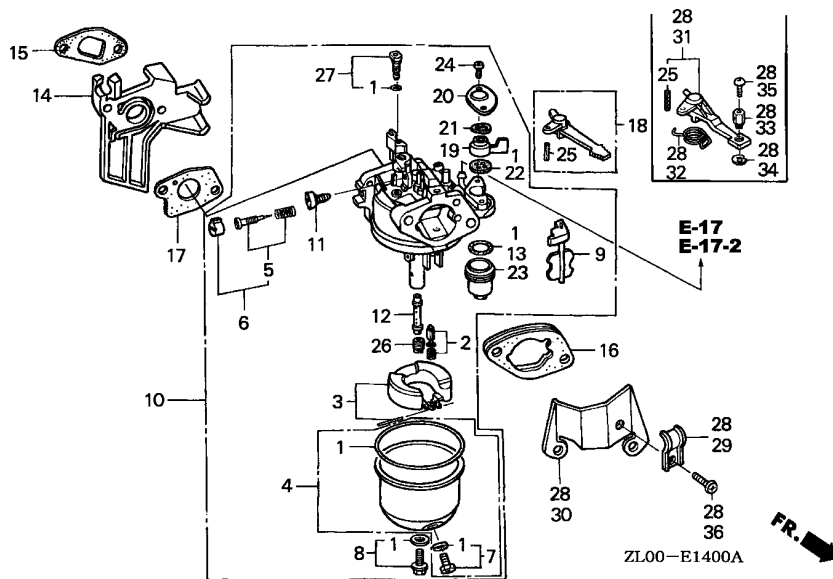

Ref. No.	Part No.	Description	Reqd. QTY			Serial No.	Parts catalogue code
			(1)	(2)	(3)		
26)	99101-ZH7-0720	JET, MAIN, #72 (CARBURETOR NO.)	(1)	-	-	BE64C A QA	
			(1)	-	-	BE69A A LD4	
	99101-ZH7-0750	JET, MAIN, #75 (CARBURETOR NO.)	1	-	-	BE64C A QA	
			1	-	-	BE69A A LD4	
	99101-ZH7-0720	JET, MAIN, #72	(1)	-	-	HXQ,QXQ	
	99101-ZH7-0750	JET, MAIN, #75	(1)	-	-	HXQ,QXQ	
	99101-ZH7-0780	JET, MAIN, #78	1	-	-	HXQ,QXQ	
	99101-ZH8-0680	JET, MAIN, #68	(1)	-	-	HX, HXU, HX2, HX26, HX4, LH, LHB2, LHP1, LHQ4, LX, LX2, LX4, NDF1, NX, PMX, PX PXU, PX2, QG, QG2, QH, QHP1, QHQ4, QH26, QSW4, QTP, QX, QXB2, QXE2, QXE4, QXE6 QXE8, QXF2, QXS2, QXU, QX2, QX26, QX4, QX7, RG, RH, RHA2, RHQ4, RH2, RH26, RMG2 RX, RXU, RX2, RX4, SH, SHQ4, SMC4, SM11, SM12, SM14, SM21, SM22, SM24, SWG4, SX SXE4, SXU, SX4, SX7, TX, TXE, TXU, TXU1, TX2, VA2, VEE1, VEN1, VES1, VGG2, VMG1 VNG4, VSD, VSD7, VX, VXU, VXU1, VX2, VX4	
		(CARBURETOR NO.)	(1)	-	-	BE64A B	QXE, QXF, TX4, UX
		//	(1)	-	-	BE64R B	SMG1
		//	(1)	-	-	BE64B B	NDJ
	99101-ZH8-0700	JET, MAIN, #70	(1)	-	-	HX, HXU, HX2, HX26, HX4, LH, LHB2, LHP1, LHQ4, LX, LX2, LX4, NDF1, NX, PMX, PX PXU, PX2, QG, QG2, QH, QHP1, QHQ4, QH26, QSW4, QTP, QX, QXB2, QXE2, QXE4, QXE6 QXE8, QXF2, QXS2, QXU, QX2, QX26, QX4, QX7, RG, RH, RHA2, RHQ4, RH2, RH26, RMG2 RX, RXU, RX2, RX4, SH, SHQ4, SMC4, SM11, SM12, SM14, SM21, SM22, SM24, SWG4, SX SXE4, SXU, SX4, SX7, TX, TXE, TXU, TXU1, TX2, VA2, VEE1, VEN1, VES1, VGG2, VMG1 VNG4, VSD, VSD7, VX, VXU, VXU1, VX2, VX4	
		(CARBURETOR NO.)	(1)	-	-	BE64A B	QXE, QXF, TX4, UX
		//	(1)	-	-	BE64R B	SMG1
		//	(1)	-	-	BE64B B	NDJ

Ref. No.	Part No.	Description	Reqd. QTY			Serial No.	Parts catalogue code	
			(1)	GX200 (2)	(3)			
26)	99101-ZH8-0720	JET, MAIN, #72	1	-	-	-----	HX, HXU, HX2, HX26, HX4, LH, LHB2, LHP1, LHQ4, LX, LX2, LX4, NDF1, NX, PMX, PX, PXU, PX2, QG, QG2, QH, QHP1, QHQ4, QH26, QSW4, QTP, QX, QXB2, QXE2, QXE4, QXE6, QXE8, QXF2, QXS2, QXU, QX2, QX26, QX4, QX7, RG, RH, RHA2, RHQ4, RH2, RH26, RMG2, RX, RXU, RX2, RX4, SH, SHQ4, SMC4, SM11, SM12, SM14, SM21, SM22, SM24, SWG4, SX, SXE4, SXU, SX4, SX7, TX, TXE, TXU, TXU1, TX2, VA2, VEE1, VEN1, VES1, VGG2, VMG1, VNG4, VSD, VSD7, VX, VXU, VXU1, VX2, VX4	
		(CARBURETOR NO.)	1	-	-	BE64A B	-----	QXE, QXF, TX4, UX
		//	1	-	-	BE64R B	-----	SMG1
		//	1	-	-	BE64B B	-----	NDJ
	99101-ZH8-0700	JET, MAIN, #70	(1)	-	-	-----	-----	BL, LD, LDB1, LDB2, LDN, LJ, LJC1, LJG, LSJ, LVL, NAX, NAX1, NJ, NJC1, NJG, NMB, NTB, NTU, NW, NWA, NWB2, QAB2, QA2, QD, QH4, QJF, QJF1, QM, QT, QTP2, QVL, QXC, QXC9, QXH4, SD, SDB1, SDB2, SDN, SD4, SJ, SJG, SMG2
		(CARBURETOR NO.)	(1)	-	-	BE64C B	-----	QA
		//	(1)	-	-	BE64E B	-----	NDJ
		//	(1)	-	-	BE69A B	-----	LD4
		//	(1)	-	-	BE64R A	-----	SMG1
			-	-	(1)			
	99101-ZH8-0720	JET, MAIN, #72	(1)	-	-	-----	-----	BL, LD, LDB1, LDB2, LDN, LJ, LJC1, LJG, LSJ, LVL, NAX, NAX1, NJ, NJC1, NJG, NMB, NTB, NTU, NW, NWA, NWB2, QAB2, QA2, QD, QH4, QJF, QJF1, QM, QT, QTP2, QVL, QXC, QXC9, QXH4, SD, SDB1, SDB2, SDN, SD4, SJ, SJG, SMG2
		(CARBURETOR NO.)	(1)	-	-	BE64C B	-----	QA
		//	(1)	-	-	BE64E B	-----	NDJ
		//	(1)	-	-	BE69A B	-----	LD4
		//	(1)	-	-	BE64R A	-----	SMG1
			-	-	(1)			
	99101-ZH8-0750	JET, MAIN, #75	1	-	-	-----	-----	BL, LD, LDB1, LDB2, LDN, LJ, LJC1, LJG, LSJ, LVL, NAX, NAX1, NJ, NJC1, NJG, NMB, NTB, NTU, NW, NWA, NWB2, QAB2, QA2, QD, QH4, QJF, QJF1, QM, QT, QTP2, QVL, QXC, QXC9, QXH4, SD, SDB1, SDB2, SDN, SD4, SJ, SJG, SMG2
		(CARBURETOR NO.)	1	-	-	BE64C B	-----	QA
		//	1	-	-	BE64E B	-----	NDJ
		//	1	-	-	BE69A B	-----	LD4
		//	1	-	-	BE64R A	-----	SMG1
			-	-	(1)			
27	99204-ZA0-0450	JET SET, PILOT, #45	1	-	-	-----	-----	BL, HX, HXQ, HXU, HX2, HX26, HX4, LD, LDB1, LDB2, LDN, LD4, LH, LHB2, LHP1, LHQ4, LJ, LJC1, LJG, LSJ, LVL, LX, LX2, LX4, NAX, NAX1, NDF1, NDJ, NJ, NJC1, NJG, NMB, NTB, NTU, NW, NWA, NWB2, NX, PMX, PX, PXU, PX2, QA, QAB2, QA2, QD, QG, QG2, QH, QHP1, QHQ4, QH26, QH4, QJF, QJF1, QM, QSW4, QT, QTP, QTP2, QVL, QX, QXB2, QXC, QXC9, QXE, QXE2, QXE4, QXE6, QXE8, QXF, QXF2, QXH4, QXQ, QXS2, QXU, QX2, QX26, QX4, QX7, RG, RH, RHA2, RHQ4, RH2, RH26, RMG2, RX, RXU, RX2, RX4, SD, SDB1, SDB2, SDN, SD4, SH, SHQ4, SJ, SJG, SMC4, SMG1, SMG2, SM11, SM12, SM14, SM21, SM22, SM24, SWG4, SX, SXE4, SXU, SX4, SX7, TX, TXE, TXU, TXU1, TX2, TX4, UX, VA2, VEE1, VEN1, VES1, VGG2, VMG1, VNG4, VSD, VSD7, VX, VXU, VXU1, VX2, VX4
			-	-	1			
28	06164-ZE1-000	CHOKE KIT, REMOTE CONTROL ...	1	-	-	-----	-----	QSW4
29	16582-883-300	HOLDER, CONTROL CABLE	1	-	-	-----	-----	NAX, NAX1, NJC1, NMB, NTB, NTU, QH4, QJF1, QSW4, QTP2, QXH4, SMG1, SMG2, SWG4
30	16598-ZE1-000	STAY, CHOKE CONTROL	1	-	-	-----	-----	NAX, NAX1, NJC1, NMB, NTB, NTU, QH4, QJF1, QSW4, QTP2, QXH4, SMG1, SMG2, SWG4
31	16610-ZE1-810	LEVER COMP., CHOKE (REMOTE) ..	1	-	-	-----	-----	NAX, NAX1, NJC1, NMB, NTB, NTU, QH4, QJF1, QSW4, QTP2, QXH4, SMG1, SMG2, SWG4
32	16615-ZE1-010	SPRING, RETURN	1	-	-	-----	-----	NAX, NAX1, NJC1, NMB, NTB, NTU, QH4, QJF1, QSW4, QTP2, QXH4, SMG1, SMG2, SWG4
33	16617-890-010	HOLDER, CABLE	1	-	-	-----	-----	NAX, NAX1, NJC1, NMB, NTB, NTU, QH4, QJF1, QSW4, QTP2, QXH4, SMG1, SMG2, SWG4
34	90605-230-000	CIRCLIP, 5MM	1	-	-	-----	-----	NAX, NAX1, NJC1, NMB, NTB, NTU, QH4, QJF1, QSW4, QTP2, QXH4, SMG1, SMG2, SWG4
35	93500-04008-0A	SCREW, PAN, 4X8	1	-	-	-----	-----	NAX, NAX1, NJC1, NMB, NTB, NTU, QH4, QJF1, QSW4, QTP2, QXH4, SMG1, SMG2, SWG4
36	93500-05008-0A	SCREW, PAN, 5X8	1	-	-	-----	-----	NAX, NAX1, NJC1, NMB, NTB, NTU, QH4, QJF1, QSW4, QTP2, QXH4, SMG1, SMG2, SWG4



E-14-1

CARBURETOR(2)

G13

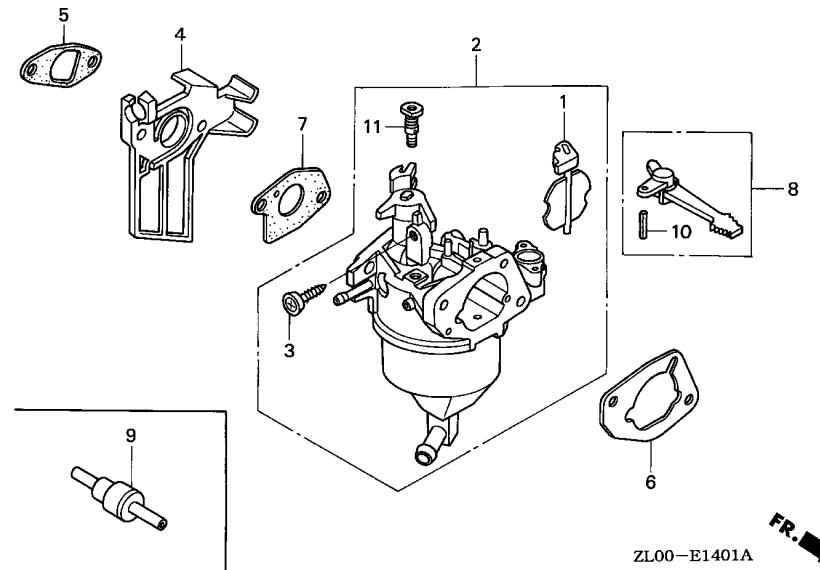

Ref. No.	L.O.N.	(Relative ref. Number) Description	F.R.T.
2	3111F3	CARBURETOR	0.2
4	3111C0	INSULATOR, CARBURETOR AND/OR PACKING, INSULATOR	0.2
6	3111D9	SPACER, CARBURETOR	0.2
7	3111C8	PACKING, CARBURETOR	0.2
8	8101F9	LEVER, CARBURETOR CHOKE	0.2
9	311175	VALVE, DASHPOT CHECK	0.1

2

Ref. No.	Part No.	Description	Reqd. QTY			Serial No.	Parts catalogue code
			(1)	GX200 (2)	(3)		
1	16044-ZL0-831	CHOKE SET	-	1	-		
2	16100-ZL0-831	CARBURETOR ASSY. (BEL1A A) ..	-	1	-		
3	16124-ZE0-005	SCREW, THROTTLE STOP	-	1	-		
4	16211-ZL0-000	INSULATOR, CARBURETOR	-	1	-		
5	16212-ZH8-800	PACKING, INSULATOR	-	1	-		
6	16220-ZE1-020	SPACER COMP., CARBURETOR	-	1	-		
7	16221-ZH8-801	PACKING, CARBURETOR	-	1	-		
8	16610-ZE1-000	LEVER COMP., CHOKE (STD.)	-	1	-		
9	36135-PH3-004	VALVE, DASHPOT CHECK	-	(1)	-		
10	94305-20122	PIN, SPRING, 2X12	-	1	-		
11	99104-ZL0-0350	JET, PILOT, #35	-	1	-		

E-14-2

CARBURETOR(3)

G14

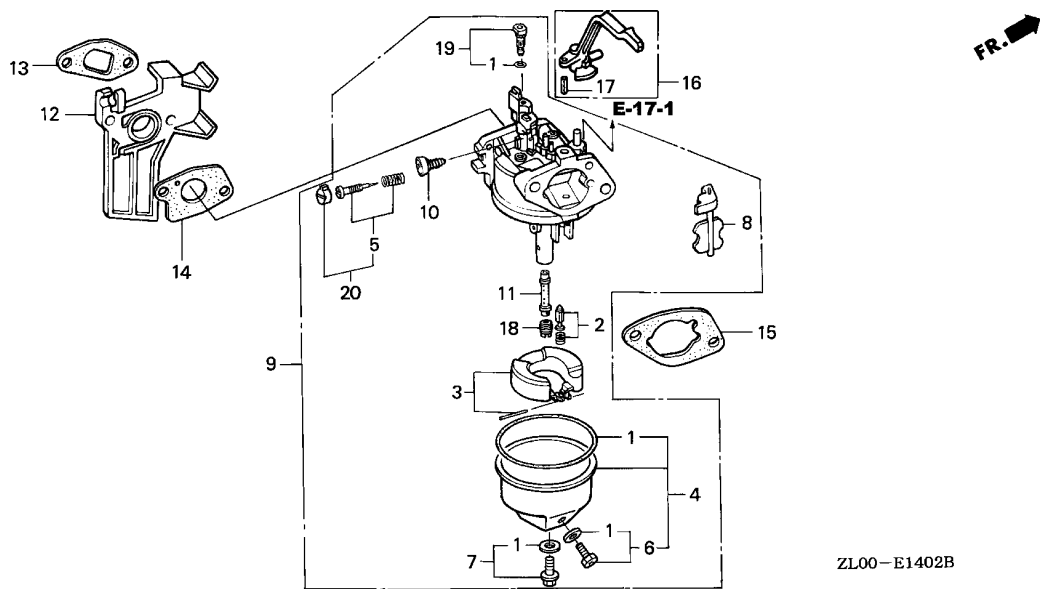

Ref. No.	L.O.N.	(Relative ref. Number) Description	F.R.T.
1	3111B1	GASKET SET, CARBURETOR (3)	0.3
2	3111E1	VALVE SET, FLOAT AND/OR FLOAT SET	0.3
8	8101C5	CHOKE SET, CARBURETOR	0.2
9	3111F3	CARBURETOR (13)	0.2
12	3111C0	INSULATOR, CARBURETOR AND/OR PACKING, INSULATOR	0.2
14	3111C8	PACKING, CARBURETOR	0.2
15	3121D9	PACKING, AIR CLEANER	0.2
16	8101F9	LEVER, CARBURETOR CHOKE	0.2
18	3111C3	JET, MAIN	0.3
20	3111D7	SCREW SET, PILOT	0.2

Ref. No.	Part No.	Description	Reqd. QTY			Serial No.	Parts catalogue code
			(1)	(2)	(3)		
1	16010-ZB1-015	GASKET SET	1	-	-	VAA,VAA1,VEN,VEN4,VES,VMT,VSD1,VSD2,VS17	
2	16011-ZE0-005	VALVE SET, FLOAT	1	-	-	VAA,VAA1,VEN,VEN4,VES,VMT,VSD1,VSD2,VS17	
3	16013-ZE0-005	FLOAT SET	1	-	-	VAA,VAA1,VEN,VEN4,VES,VMT,VSD1,VSD2,VS17	
4	16015-ZE0-831	CHAMBER SET, FLOAT	1	-	-	VAA,VAA1,VEN,VEN4,VES,VMT,VSD1,VSD2,VS17	
5	16016-ZE0-005	SCREW SET, PILOT	1	-	-	VAA,VAA1,VEN,VEN4,VES,VMT,VSD1,VS17	
6	16024-ZE1-811	SCREW SET, DRAIN	1	-	-	VAA,VAA1,VEN,VEN4,VES,VMT,VSD1,VSD2,VS17	
7	16028-ZE0-005	SCREW SET	1	-	-	VAA,VAA1,VEN,VEN4,VES,VMT,VSD1,VSD2,VS17	
8	16044-ZE0-005	CHOKE SET	1	-	-	VAA,VAA1,VEN,VEN4,VES,VMT,VSD1,VSD2,VS17	
9	16100-ZL0-V31	CARBURETOR ASSY. (BE74A B)	1	-	-	VAA,VAA1,VEN,VEN4,VES,VMT,VSD1,VS17	
	16100-ZK0-U01	CARBURETOR ASSY. (BE74H A)	1	-	-	VSD2	
10	16124-ZE0-005	SCREW, THROTTLE STOP	1	-	-	VAA,VAA1,VEN,VEN4,VES,VMT,VSD1,VSD2,VS17	
11	16166-ZL0-000	NOZZLE, MAIN	1	-	-	VAA,VAA1,VEN,VEN4,VES,VMT,VSD1,VSD2,VS17	
12	16211-ZL0-000	INSULATOR, CARBURETOR	1	-	-	VAA,VAA1,VEN,VEN4,VES,VMT,VSD1,VSD2,VS17	
13	16212-ZH8-800	PACKING, INSULATOR	1	-	-	VAA,VAA1,VEN,VEN4,VES,VMT,VSD1,VSD2,VS17	
14	16221-ZH8-801	PACKING, CARBURETOR	1	-	-	VAA,VAA1,VEN,VEN4,VES,VMT,VSD1,VSD2,VS17	
15	16269-ZE1-800	PACKING, AIR CLEANER	1	-	-	VAA,VAA1,VEN,VEN4,VES,VMT,VSD1,VSD2,VS17	
16	16610-ZB2-000	LEVER COMP., CHOKE	1	-	-	VAA,VAA1,VEN,VEN4,VES,VMT,VSD1,VSD2,VS17	
17	94305-20122	PIN, SPRING, 2X12	1	-	-	VAA,VAA1,VEN,VEN4,VES,VMT,VSD1,VSD2,VS17	
18	99101-ZH8-0720	JET, MAIN, #72	(1)	-	-	VAA,VAA1,VEN,VEN4,VES,VMT,VSD1,VSD2,VS17	
	99101-ZH8-0750	JET, MAIN, #75	(1)	-	-	VAA,VAA1,VEN,VEN4,VES,VMT,VSD1,VSD2,VS17	
	99101-ZH8-0780	JET, MAIN, #78	1	-	-	VAA,VAA1,VEN,VEN4,VES,VMT,VSD1,VSD2,VS17	
19	99204-ZE2-0400	JET SET, PILOT, #40	1	-	-	VAA,VAA1,VEN,VEN4,VES,VMT,VSD1,VSD2,VS17	
20	16016-ZH7-W01	SCREW SET, PILOT	1	-	-	VSD2	

2

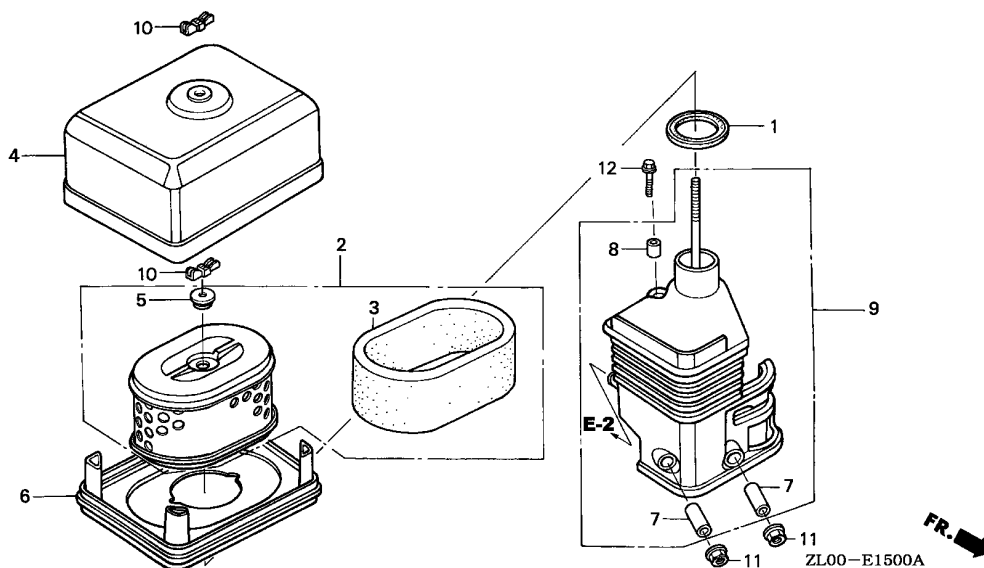

Ref. No.	L.O.N.	(Relative ref. Number) Description	F.R.T.
1	3121E1	PACKING, ELBOW	0.1
2	3121B8	ELEMENT, AIR CLEANER	0.1
3	3121C1	FILTER, OUTER	0.1
6	3121D6	NOSE, SILENCER	0.1
9	3121B4	ELBOW, AIR CLEANER	0.1



Ref. No.	Part No.	Description	Reqd. QTY			Serial No.	Parts catalogue code
			(1)	GX200 (2)	(3)		
1	16271-ZE1-000	PACKING, ELBOW	1	-	-	-	HX, HXQ, HXU, HX2, HX26, HX4, LH, LHB2, LHP1, LHQ4, LX, LX2, LX4, NDF1, NDJ, NX, PMX, PX, PXU, PX2, QG, QG2, QH, QHP1, QHQ4, QH26, QSW4, QTP, QX, QXB2, QXE, QXE2, QXE4, QXE6, QXE8, QXF, QXF2, QXQ, QXS2, QXU, QX2, QX26, QX4, QX7, RG, RH, RHA2, RHQ4, RH2, RH26, RMG2, RX, RXU, RX2, RX4, SH, SHQ4, SMC4, SMG1, SM11, SM12, SM14, SM21, SM22, SM24, SWG4, SX, SXE4, SXU, SX4, SX7, TX, TXE, TXU, TXU1, TX2, TX4, UX, VA2, VEN1, VES1, VGG2, VMG1, VNG4, VSD, VSD7, VX, VXU, VXU1, VX2, VX4, VEE1
			1	-	-	1113370	
2	17210-ZE1-822	ELEMENT, AIR CLEANER (DUAL) -	1	-	-	-	HX, HXQ, HXU, HX2, HX26, HX4, LH, LHB2, LHP1, LHQ4, LX, LX2, LX4, NDF1, NDJ, NX, PMX, PX, PXU, PX2, QG, QG2, QH, QHP1, QHQ4, QH26, QSW4, QTP, QX, QXB2, QXE, QXE2, QXE4, QXE6, QXE8, QXF, QXF2, QXQ, QXS2, QXU, QX2, QX26, QX4, QX7, RG, RH, RHA2, RHQ4, RH2, RH26, RMG2, RX, RXU, RX2, RX4, SH, SHQ4, SMC4, SMG1, SM11, SM12, SM14, SM21, SM22, SM24, SWG4, SX, SXE4, SXU, SX4, SX7, TX, TXE, TXU, TXU1, TX2, TX4, UX, VA2, VEN1, VES1, VGG2, VMG1, VNG4, VSD, VSD7, VX, VXU, VXU1, VX2, VX4, VEE1
			1	-	-	1113370	
3	17218-ZE1-821	FILTER, OUTER	1	-	-	-	HX, HXQ, HXU, HX2, HX26, HX4, LH, LHB2, LHP1, LHQ4, LX, LX2, LX4, NDF1, NDJ, NX, PMX, PX, PXU, PX2, QG, QG2, QH, QHP1, QHQ4, QH26, QSW4, QTP, QX, QXB2, QXE, QXE2, QXE4, QXE6, QXE8, QXF, QXF2, QXQ, QXS2, QXU, QX2, QX26, QX4, QX7, RG, RH, RHA2, RHQ4, RH2, RH26, RMG2, RX, RXU, RX2, RX4, SH, SHQ4, SMC4, SMG1, SM11, SM12, SM14, SM21, SM22, SM24, SWG4, SX, SXE4, SXU, SX4, SX7, TX, TXE, TXU, TXU1, TX2, TX4, UX, VA2, VEN1, VES1, VGG2, VMG1, VNG4, VSD, VSD7, VX, VXU, VXU1, VX2, VX4, VEE1
			1	-	-	1113370	

Ref. No.	Part No.	Description	Reqd. QTY			Serial No.	Parts catalogue code	
			(1)	GX200 (2)	(3)			
4	17230-ZE1-820	COVER, AIR CLEANER (DUAL) ...	1	-	-	-----	HX, HXQ, HXU, HX2, HX26, HX4, LH, LHB2, LHP1, LHQ4, LX, LX2, LX4, NDF1, NDJ, NX, PMX, PX, PXU, PX2, QG, QG2, QH, QHP1, QHQ4, QH26, QSW4, QTP, QX, QXB2, QXE, QXE2, QXE4, QXE6, QXE8, QXF, QXF2, QXQ, QXS2, QXU, QX2, QX26, QX4, QX7, RG, RH, RHA2, RHQ4, RH2, RH26, RMG2, RX, RXU, RX2, RX4, SH, SHQ4, SMC4, SMG1, SM11, SM12, SM14, SM21, SM22, SM24, SWG4, SX, SXE4, SXU, SX4, SX7, TX, TXE, TXU, TXU1, TX2, TX4, UX, VA2, VEN1, VES1, VGG2, VMG1, VNG4, VSD, VSD7, VX, VXU, VXU1, VX2, VX4	
			1	-	-	1113370	-----	VEE1
5	17232-891-000	GROMMET, AIR CLEANER	1	-	-	-----	HX, HXQ, HXU, HX2, HX26, HX4, LH, LHB2, LHP1, LHQ4, LX, LX2, LX4, NDF1, NDJ, NX, PMX, PX, PXU, PX2, QG, QG2, QH, QHP1, QHQ4, QH26, QSW4, QTP, QX, QXB2, QXE, QXE2, QXE4, QXE6, QXE8, QXF, QXF2, QXQ, QXS2, QXU, QX2, QX26, QX4, QX7, RG, RH, RHA2, RHQ4, RH2, RH26, RMG2, RX, RXU, RX2, RX4, SH, SHQ4, SMC4, SMG1, SM11, SM12, SM14, SM21, SM22, SM24, SWG4, SX, SXE4, SXU, SX4, SX7, TX, TXE, TXU, TXU1, TX2, TX4, UX, VA2, VEN1, VES1, VGG2, VMG1, VNG4, VSD, VSD7, VX, VXU, VXU1, VX2, VX4	
			1	-	-	1113370	-----	VEE1
6	17235-ZE1-831	NOSE, SILENCER	1	-	-	-----	HX, HXQ, HXU, HX2, HX26, HX4, LH, LHB2, LHP1, LHQ4, LX, LX2, LX4, NDF1, NDJ, NX, PMX, PX, PXU, PX2, QG, QG2, QH, QHP1, QHQ4, QH26, QSW4, QTP, QX, QXB2, QXE, QXE2, QXE4, QXE6, QXE8, QXF, QXF2, QXQ, QXS2, QXU, QX2, QX26, QX4, QX7, RG, RH, RHA2, RHQ4, RH2, RH26, RMG2, RX, RXU, RX2, RX4, SH, SHQ4, SMC4, SMG1, SM11, SM12, SM14, SM21, SM22, SM24, SWG4, SX, SXE4, SXU, SX4, SX7, TX, TXE, TXU, TXU1, TX2, TX4, UX, VA2, VEN1, VES1, VGG2, VMG1, VNG4, VSD, VSD7, VX, VXU, VXU1, VX2, VX4	
			1	-	-	1113370	-----	VEE1
7	17238-ZE7-010	COLLAR, AIR CLEANER	2	-	-	-----	HX, HXQ, HXU, HX2, HX26, HX4, LH, LHB2, LHP1, LHQ4, LX, LX2, LX4, NDF1, NDJ, NX, PMX, PX, PXU, PX2, QG, QG2, QH, QHP1, QHQ4, QH26, QSW4, QTP, QX, QXB2, QXE, QXE2, QXE4, QXE6, QXE8, QXF, QXF2, QXQ, QXS2, QXU, QX2, QX26, QX4, QX7, RG, RH, RHA2, RHQ4, RH2, RH26, RMG2, RX, RXU, RX2, RX4, SH, SHQ4, SMC4, SMG1, SM11, SM12, SM14, SM21, SM22, SM24, SWG4, SX, SXE4, SXU, SX4, SX7, TX, TXE, TXU, TXU1, TX2, TX4, UX, VA2, VEN1, VES1, VGG2, VMG1, VNG4, VSD, VSD7, VX, VXU, VXU1, VX2, VX4	
			2	-	-	1113370	-----	VEE1
8	17239-ZE1-000	COLLAR B, AIR CLEANER	1	-	-	-----	HX, HXQ, HXU, HX2, HX26, HX4, LH, LHB2, LHP1, LHQ4, LX, LX2, LX4, NDF1, NDJ, NX, PMX, PX, PXU, PX2, QG, QG2, QH, QHP1, QHQ4, QH26, QSW4, QTP, QX, QXB2, QXE, QXE2, QXE4, QXE6, QXE8, QXF, QXF2, QXQ, QXS2, QXU, QX2, QX26, QX4, QX7, RG, RH, RHA2, RHQ4, RH2, RH26, RMG2, RX, RXU, RX2, RX4, SH, SHQ4, SMC4, SMG1, SM11, SM12, SM14, SM21, SM22, SM24, SWG4, SX, SXE4, SXU, SX4, SX7, TX, TXE, TXU, TXU1, TX2, TX4, UX, VA2, VEN1, VES1, VGG2, VMG1, VNG4, VSD, VSD7, VX, VXU, VXU1, VX2, VX4	
			1	-	-	1113370	-----	VEE1
9	17410-ZE1-020	ELBOW COMP., AIR CLEANER	1	-	-	-----	HX, HXQ, HXU, HX2, HX26, HX4, LH, LHB2, LHP1, LHQ4, LX, LX2, LX4, NDF1, NDJ, NX, PMX, PX, PXU, PX2, QG, QG2, QH, QHP1, QHQ4, QH26, QSW4, QTP, QX, QXB2, QXE, QXE2, QXE4, QXE6, QXE8, QXF, QXF2, QXQ, QXS2, QXU, QX2, QX26, QX4, QX7, RG, RH, RHA2, RHQ4, RH2, RH26, RMG2, RX, RXU, RX2, RX4, SH, SHQ4, SMC4, SMG1, SM11, SM12, SM14, SM21, SM22, SM24, SWG4, SX, SXE4, SXU, SX4, SX7, TX, TXE, TXU, TXU1, TX2, TX4, UX, VA2, VEN1, VES1, VGG2, VMG1, VNG4, VSD, VSD7, VX, VXU, VXU1, VX2, VX4	
			1	-	-	1113370	-----	VEE1
10	90325-044-000	NUT, TOOL BOX SETTING	2	-	-	-----	HX, HXQ, HXU, HX2, HX26, HX4, LH, LHB2, LHP1, LHQ4, LX, LX2, LX4, NDF1, NDJ, NX, PMX, PX, PXU, PX2, QG, QG2, QH, QHP1, QHQ4, QH26, QSW4, QTP, QX, QXB2, QXE, QXE2, QXE4, QXE6, QXE8, QXF, QXF2, QXQ, QXS2, QXU, QX2, QX26, QX4, QX7, RG, RH, RHA2, RHQ4, RH2, RH26, RMG2, RX, RXU, RX2, RX4, SH, SHQ4, SMC4, SMG1, SM11, SM12, SM14, SM21, SM22, SM24, SWG4, SX, SXE4, SXU, SX4, SX7, TX, TXE, TXU, TXU1, TX2, TX4, UX, VA2, VEN1, VES1, VGG2, VMG1, VNG4, VSD, VSD7, VX, VXU, VXU1, VX2, VX4	
			2	-	-	1113370	-----	VEE1



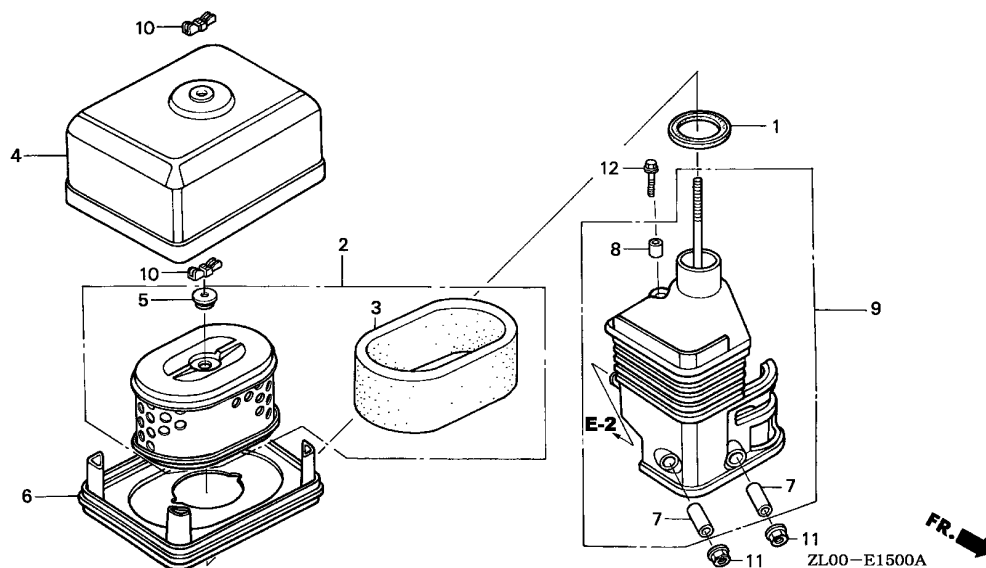

Ref. No.	Part No.	Description	Reqd. QTY			Serial No.	Parts catalogue code
			(1)	GX200 (2)	(3)		
11	94050-06000	NUT, FLANGE, 6MM	2	-	-		HX, HXQ, HXU, HX2, HX26, HX4, LH, LHB2, LHP1, LHQ4, LX, LX2, LX4, NDF1, NDJ, NX, PMX, PX, PXU, PX2, QG, QG2, QH, QHP1, QHQ4, QH26, QSW4, QTP, QX, QXB2, QXE, QXE2, QXE4, QXE6, QXE8, QXF, QXF2, QXQ, QXS2, QXU, QX2, QX26, QX4, QX7, RG, RH, RHA2, RHQ4, RH2, RH26, RMG2, RX, RXU, RX2, RX4, SH, SHQ4, SMC4, SMG1, SM11, SM12, SM14, SM21, SM22, SM24, SWG4, SX, SXE4, SXU, SX4, SX7, TX, TXE, TXU, TXU1, TX2, TX4, UX, VA2, VEN1, VES1, VGG2, VMG1, VNG4, VSD, VSD7, VX, VXU, VXU1, VX2, VX4
			2	-	-	1113370	VEE1
12	95701-06020-00	BOLT, FLANGE, 6X20	1	-	-		HX, HXQ, HXU, HX2, HX26, HX4, LH, LHB2, LHP1, LHQ4, LX, LX2, LX4, NDF1, NDJ, NX, PMX, PX, PXU, PX2, QG, QG2, QH, QHP1, QHQ4, QH26, QSW4, QTP, QX, QXB2, QXE, QXE2, QXE4, QXE6, QXE8, QXF, QXF2, QXQ, QXS2, QXU, QX2, QX26, QX4, QX7, RG, RH, RHA2, RHQ4, RH2, RH26, RMG2, RX, RXU, RX2, RX4, SH, SHQ4, SMC4, SMG1, SM11, SM12, SM14, SM21, SM22, SM24, SWG4, SX, SXE4, SXU, SX4, SX7, TX, TXE, TXU, TXU1, TX2, TX4, UX, VA2, VEN1, VES1, VGG2, VMG1, VNG4, VSD, VSD7, VX, VXU, VXU1, VX2, VX4
			1	-	-	1113370	VEE1
			-	1	-		

E-15-1

AIR CLEANER(SEMI DRY)

H 2

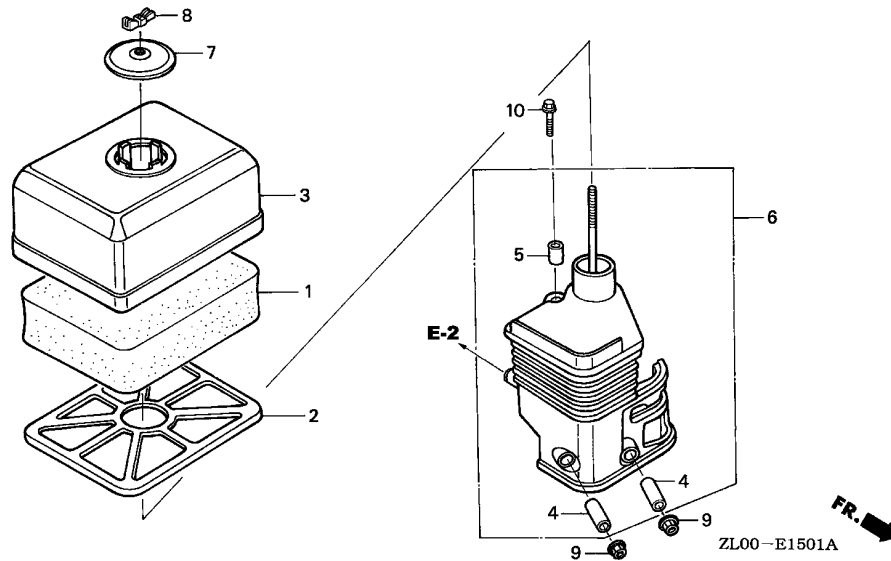

Ref. No.	L.O.N.	(Relative ref. Number) Description	F.R.T.
1	3121B8	ELEMENT, AIR CLEANER	0.1
6	3121B4	ELBOW, AIR CLEANER	0.1

Ref. No.	Part No.	Description	Reqd. QTY			Serial No.	Parts catalogue code
			(1)	(2)	(3)		
1	17211-ZE1-000	ELEMENT, AIR CLEANER (SEMI DRY)	1	-	-	LD,LDB1,LDB2,LDN,LD4,LJ,LJC1,LJG,LSJ,NAX,NAX1,NJ,NJC1,NJG,NMB,NTB NTU,QD,QJF,QJF1,QM,SD,SDB1,SDB2,SDN,SD4,SJ,SJG,SMG2	1113369 VEE1
2	17212-ZE1-000	GRID, AIR CLEANER (SEMI DRY)	1	-	1	LD,LDB1,LDB2,LDN,LD4,LJ,LJC1,LJG,LSJ,NAX,NAX1,NJ,NJC1,NJG,NMB,NTB NTU,QD,QJF,QJF1,QM,SD,SDB1,SDB2,SDN,SD4,SJ,SJG,SMG2	1113369 VEE1
3	17231-ZE1-000	COVER, AIR CLEANER (SEMI DRY)	1	-	-	LD,LDB1,LDB2,LDN,LD4,LJ,LJC1,LJG,LSJ,NAX,NAX1,NJ,NJC1,NJG,NMB,NTB NTU,QD,QJF,QJF1,QM,SD,SDB1,SDB2,SDN,SD4,SJ,SJG,SMG2	1113369 VEE1
4	17238-ZE7-010	COLLAR, AIR CLEANER	2	-	-	LD,LDB1,LDB2,LDN,LD4,LJ,LJC1,LJG,LSJ,NAX,NAX1,NJ,NJC1,NJG,NMB,NTB NTU,QD,QJF,QJF1,QM,SD,SDB1,SDB2,SDN,SD4,SJ,SJG,SMG2	1113369 VEE1
5	17239-ZE1-000	COLLAR B, AIR CLEANER	1	-	-	LD,LDB1,LDB2,LDN,LD4,LJ,LJC1,LJG,LSJ,NAX,NAX1,NJ,NJC1,NJG,NMB,NTB NTU,QD,QJF,QJF1,QM,SD,SDB1,SDB2,SDN,SD4,SJ,SJG,SMG2	1113369 VEE1
6	17410-ZE1-020	ELBOW COMP., AIR CLEANER	1	-	-	LD,LDB1,LDB2,LDN,LD4,LJ,LJC1,LJG,LSJ,NAX,NAX1,NJ,NJC1,NJG,NMB,NTB NTU,QD,QJF,QJF1,QM,SD,SDB1,SDB2,SDN,SD4,SJ,SJG,SMG2	1113369 VEE1

2

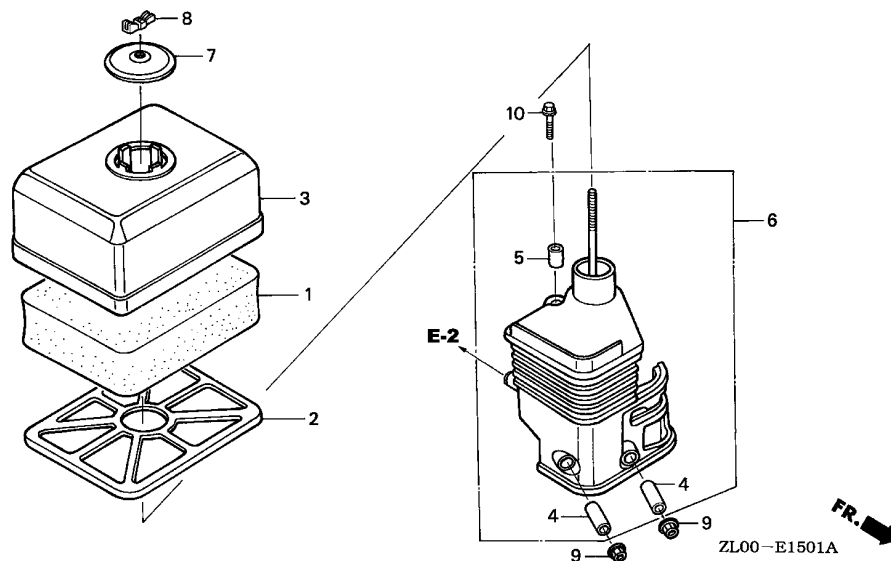

Ref. No.	Part No.	Description	Reqd. QTY			Serial No.	Parts catalogue code
			(1)	GX200 (2)	(3)		
7	17421-ZE1-000	CAP, CLEANER	1	-	-	LD,LDB1,LDB2,LDN,LD4,LJ,LJC1,LJG,LSJ,NAX,NAX1,NJ,NJC1,NJG,NMB,NTB NTU,QD,QJF,QJF1,QM,SD,SDB1,SDB2,SDN,SD4,SJ,SJG,SMG2	
			-	-	1	1113369	VEE1
8	90325-044-000	NUT, TOOL BOX SETTING	1	-	-	LD,LDB1,LDB2,LDN,LD4,LJ,LJC1,LJG,LSJ,NAX,NAX1,NJ,NJC1,NJG,NMB,NTB NTU,QD,QJF,QJF1,QM,SD,SDB1,SDB2,SDN,SD4,SJ,SJG,SMG2	
			-	-	1	1113369	VEE1
9	94050-06000	NUT, FLANGE, 6MM	2	-	-	LD,LDB1,LDB2,LDN,LD4,LJ,LJC1,LJG,LSJ,NAX,NAX1,NJ,NJC1,NJG,NMB,NTB NTU,QD,QJF,QJF1,QM,SD,SDB1,SDB2,SDN,SD4,SJ,SJG,SMG2	
			2	-	-	1113369	VEE1
10	95701-06020-00	BOLT, FLANGE, 6X20	1	-	-	LD,LDB1,LDB2,LDN,LD4,LJ,LJC1,LJG,LSJ,NAX,NAX1,NJ,NJC1,NJG,NMB,NTB NTU,QD,QJF,QJF1,QM,SD,SDB1,SDB2,SDN,SD4,SJ,SJG,SMG2	
			1	-	-	1113369	VEE1
			-	-	1		

E-15-2

AIR CLEANER(CYCLONE)

H 4

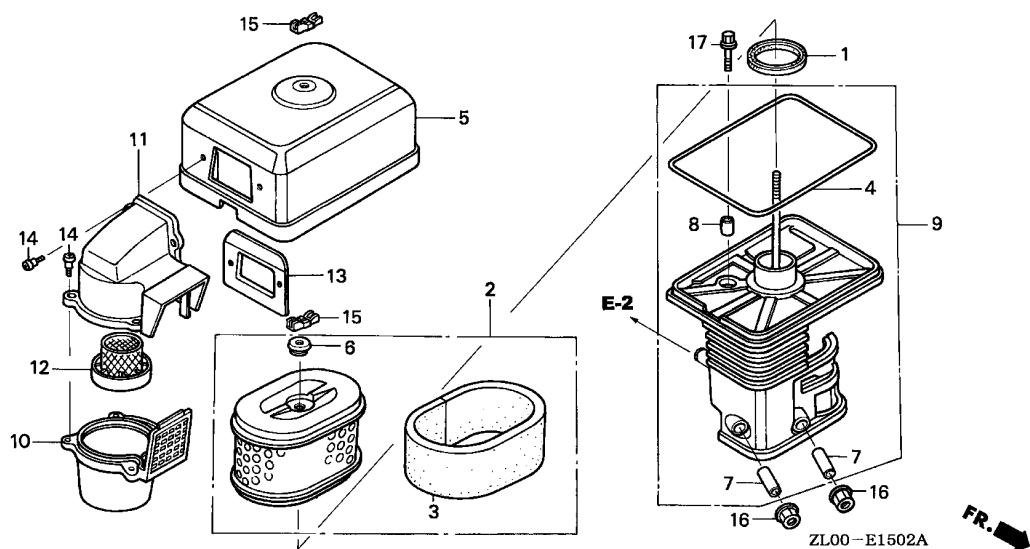

Ref. No.	L.O.N.	(Relative ref. Number) Description	F.R.T.
2	3121B8	ELEMENT, AIR CLEANER	0.1
3	3121C1	FILTER, OUTER	0.1
4	3121E0	PACKING, AIR CLEANER COVER	0.1
9	3121B4	ELBOW, AIR CLEANER	0.1
10	3121A6	CASE, PRE AIR CLEANER	0.1
11	3121A4	CAP, PRE AIR CLEANER	0.1
12	3121C8	GUIDE, PRE AIR CLEANER	0.1

Ref. No.	Part No.	Description	Reqd. QTY			Serial No.	Parts catalogue code
			(1)	GX200 (2)	(3)		
1	16271-ZE1-000	PACKING, ELBOW	1	-	-	QH4,QTP2,QXC,QXC9,QXH4	
2	17210-ZE1-822	ELEMENT, AIR CLEANER (DUAL)	1	-	-	QH4,QTP2,QXC,QXC9,QXH4	
3	17218-ZE1-821	FILTER, OUTER	1	-	-	QH4,QTP2,QXC,QXC9,QXH4	
4	17219-733-010	PACKING, AIR CLEANER COVER	1	-	-	QH4,QTP2,QXC,QXC9,QXH4	
5	17230-ZE1-841	COVER, AIR CLEANER (DUAL)	1	-	-	QH4,QTP2,QXC,QXC9,QXH4	
6	17232-891-000	GROMMET, AIR CLEANER	1	-	-	QH4,QTP2,QXC,QXC9,QXH4	
7	17238-ZE7-010	COLLAR, AIR CLEANER	2	-	-	QH4,QTP2,QXC,QXC9,QXH4	
8	17239-733-000	COLLAR B, AIR CLEANER	1	-	-	QH4,QTP2,QXC,QXC9,QXH4	
9	17410-ZE1-840	ELBOW COMP., AIR CLEANER	1	-	-	QH4,QTP2,QXC,QXC9,QXH4	
10	17470-ZE1-841	CASE, PRE AIR CLEANER	1	-	-	QXC	
	17470-ZE1-842	1	-	-	QH4,QTP2,QXC9,QXH4	
11	17475-ZE1-841	CAP, PRE AIR CLEANER	1	-	-	QH4,QTP2,QXC,QXC9,QXH4	
12	17476-ZE1-841	GUIDE, PRE AIR CLEANER	1	-	-	QH4,QTP2,QXC,QXC9,QXH4	
13	17478-ZE1-841	PLATE, PRE AIR CLEANER	1	-	-	QH4,QTP2,QXC,QXC9,QXH4	
14	90300-GB0-900	BOLT, MUDGUARD	5	-	-	QH4,QTP2,QXC,QXC9,QXH4	
15	90325-044-000	NUT, TOOL BOX SETTING	2	-	-	QH4,QTP2,QXC,QXC9,QXH4	
16	94050-06000	NUT, FLANGE, 6MM	2	-	-	QH4,QTP2,QXC,QXC9,QXH4	
17	95701-06020-00	BOLT, FLANGE, 6X20	1	-	-	QH4,QTP2,QXC,QXC9,QXH4	

2

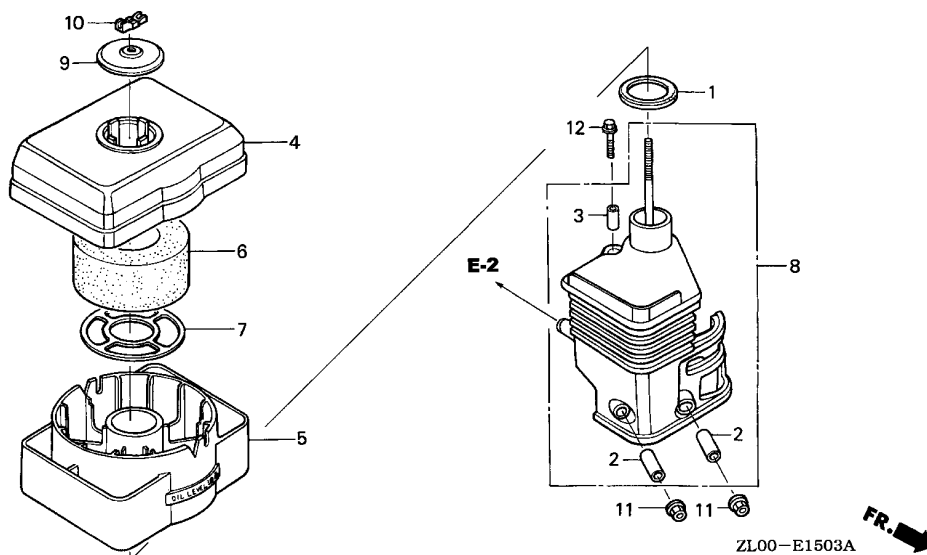

Ref. No.	L.O.N.	(Relative ref. Number) Description	F.R.T.
1	3121E1	PACKING, ELBOW	0.1
5	3121E5	PAN, AIR CLEANER OIL	0.1
6		(7)	
	3121B8	ELEMENT, AIR CLEANER	0.1
8	3121B4	ELBOW, AIR CLEANER	0.1



Ref. No.	Part No.	Description	Reqd. QTY			Serial No.	Parts catalogue code
			(1)	GX200 (2)	(3)		
1	16271-ZE1-000	PACKING, ELBOW	1	-	-	BL,LVL,NW,NWA,NWB2,QA,QAB2,QA2,QT,QVL	
2	17238-ZE7-010	COLLAR, AIR CLEANER	2	-	-	BL,LVL,NW,NWA,NWB2,QA,QAB2,QA2,QT,QVL	
3	17239-ZE1-000	COLLAR B, AIR CLEANER	1	-	-	BL,LVL,NW,NWA,NWB2,QA,QAB2,QA2,QT,QVL	
4	17401-ZE1-810	BODY, CLEANER (OIL BATH)	1	-	-	BL,LVL,NW,NWA,NWB2,QA,QAB2,QA2,QT,QVL	
5	17402-ZE1-810	PAN, CLEANER OIL (OIL BATH)	1	-	-	BL,LVL,NW,NWA,NWB2,QA,QAB2,QA2,QT,QVL	
6	17403-ZE1-810	ELEMENT, AIR CLEANER (OIL BATH)	1	-	-	BL,LVL,NW,NWA,NWB2,QA,QAB2,QA2,QT,QVL	
7	17404-841-000	GRID, AIR CLEANER	1	-	-	BL,LVL,NW,NWA,NWB2,QA,QAB2,QA2,QT,QVL	
8	17410-ZE1-020	ELBOW COMP., AIR CLEANER	1	-	-	BL,LVL,NW,NWA,NWB2,QA,QAB2,QA2,QT,QVL	
9	17421-ZE1-000	CAP, CLEANER	1	-	-	BL,LVL,NW,NWA,NWB2,QA,QAB2,QA2,QT,QVL	
10	90325-044-000	NUT, TOOL BOX SETTING	1	-	-	BL,LVL,NW,NWA,NWB2,QA,QAB2,QA2,QT,QVL	
11	94050-06000	NUT, FLANGE, 6MM	2	-	-	BL,LVL,NW,NWA,NWB2,QA,QAB2,QA2,QT,QVL	
12	95701-06020-00	BOLT, FLANGE, 6X20	1	-	-	BL,LVL,NW,NWA,NWB2,QA,QAB2,QA2,QT,QVL	

E-15-4

AIR CLEANER(STANDARD)

H 6

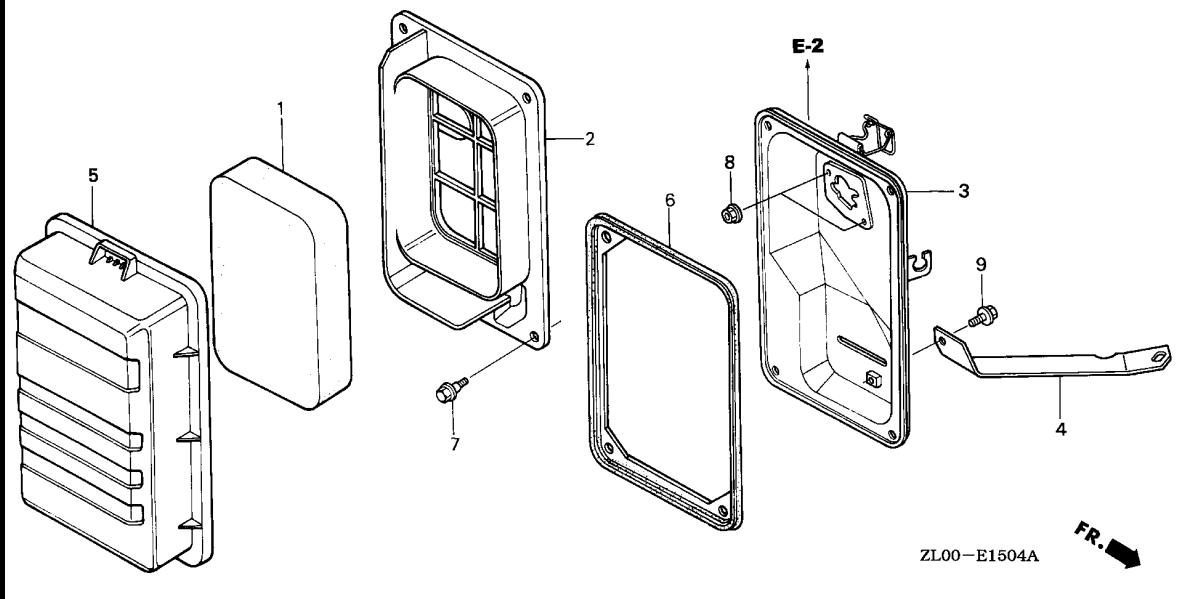

Ref. No.	L.O.N.	(Relative ref. Number) Description	F.R.T.
1	3121B8	ELEMENT, AIR CLEANER	0.1
2	3121F0	SEPARATOR, AIR CLEANER	0.1
3	3121A5	CASE, AIR CLEANER	0.1
6	3121E8	SEAL, AIR CLEANER CASE	0.1

Ref. No.	Part No.	Description	Reqd. QTY			Serial No.	Parts catalogue code
			(1)	GX200 (2)	(3)		
1	17211-ZB2-000	ELEMENT, AIR CLEANER	1	-	-	VAA,VAA1,VEN,VEN4,VES,VMT,VSD1,VSD2,VS17	
2	17212-ZB2-000	SEPARATOR, AIR CLEANER	1	-	-	VAA,VAA1,VEN,VEN4,VES,VMT,VSD1,VSD2,VS17	
3	17220-ZB2-000	CASE COMP., AIR CLEANER	1	-	-	VAA,VAA1,VEN,VEN4,VES,VMT,VSD1,VSD2,VS17	
4	17222-ZL0-V30	STAY, AIR CLEANER	1	-	-	VAA,VAA1,VEN,VEN4,VES,VMT,VSD1,VSD2,VS17	
5	17231-ZB2-000	COVER, AIR CLEANER	1	-	-	VAA,VAA1,VEN,VEN4,VES,VMT,VSD1,VSD2,VS17	
6	17252-ZB2-000	SEAL, AIR CLEANER	1	-	-	VAA,VAA1,VEN,VEN4,VES,VMT,VSD1,VSD2,VS17	
7	90115-459-770	BOLT, WINKER SETTING	4	-	-	VAA,VAA1,VEN,VEN4,VES,VMT,VSD1,VSD2,VS17	
8	94050-06080	NUT, FLANGE, 6MM	2	-	-	VAA,VAA1,VEN,VEN4,VES,VMT,VSD1,VSD2,VS17	
9	95701-06010-00	BOLT, FLANGE, 6X10	1	-	-	VAA1,VEN,VEN4,VES,VMT,VSD1,VSD2,VS17	
	95701-06018-00	BOLT, FLANGE, 6X18	1	-	-	VAA	

2

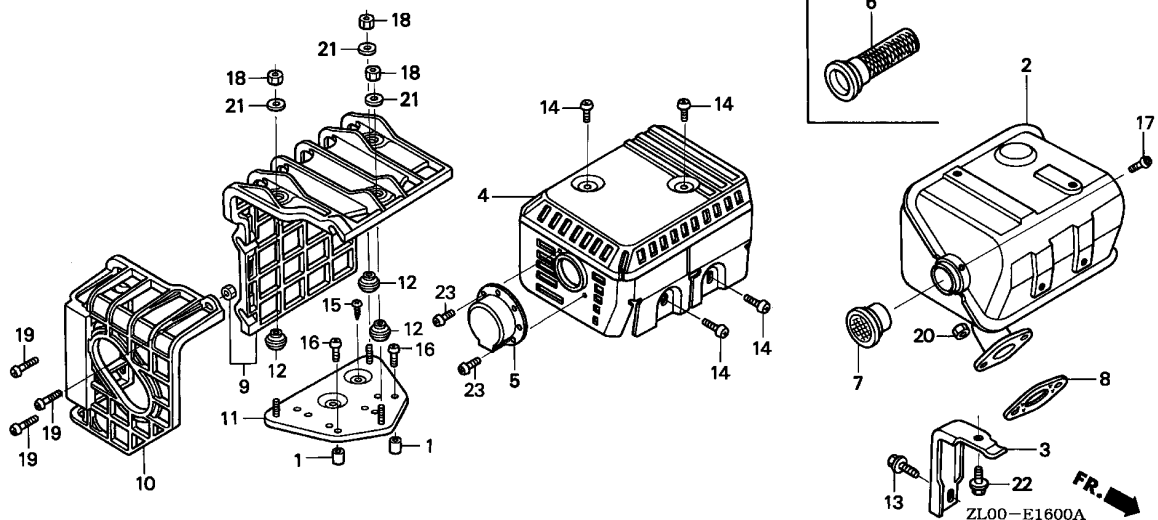

Ref. No.	L.O.N.	(Relative ref. Number) Description	F.R.T.
2	3131C5	MUFFLER, EXHAUST	0.2
4	3131D6	PROTECTOR, EXHAUST MUFFLER ...	0.2
6	3131A1	ARRESTER, SPARK	0.2
8	3131B4	GASKET, EXHAUST MUFFLER	0.2
9	3131A7	COVER, EXHAUST MUFFLER	0.1
10	3131A6	COVER, EXHAUST MUFFLER :REAR -	0.1
11	3131A2	BASE, EXHAUST MUFFLER COVER ..	0.2



Ref. No.	Part No.	Description	Reqd. QTY			Serial No.	Parts catalogue code
			(1)	(2)	(3)		
1	17233-896-701	COLLAR, AIR CLEANER CASE	(2)	(2)	-	HX4,LD4,LHQ4,LX4,QG,QHQ4,QSW4,QXE4,QX4,QX7,RG,RHQ4,RX4,SD4,SHQ4,SMC4,SM14,SM24,SXE4,SX4,SX7,TX4,VNG4,VSD,VSD1,VSD2,VSD7,VX4,VX4P	
2	18310-ZLO-800	MUFFLER COMP. (ARRESTER)	1	-	-	QA,QA2,QG2,QH4,QXH4,RMG2,VA2,VGG2	
			(1)	-	-	1383992 QAB2	
	18310-ZLO-000	MUFFLER COMP.	1	-	-	RX2	
						HX,HXQ,HXU,HX2,HX26,HX4,LD,LDB1,LDB2,LDN,LD4,LH,LHB2,LHP1,LHQ4,LJ	
						LJC1,LJG,LSJ,LX,LX2,LX4,NAX,NAX1,NDF1,NDJ,NJ,NJG,NMB,NTB,NW,NWA	
						NWB2,NX,PMX,PX,PXU,PX2,QD,QG,QH,QHP1,QHQ4,QH26,QJF,QM,QSW4,QT,QTP	
						QTP2,QX,QXB2,QXC,QXC9,QXE,QXE2,QXE4,QXE6,QXE8,QXF,QXF2,QXQ,QXS2	
						QXU,QX2,QX26,QX4,QX7,RG,RH,RHA2,RHQ4,RH2,RH26,RX,RXU,RX2,RX4,SD	
						SDB1,SDB2,SDN,SD4,SH,SHQ4,SJ,SJG,SMC4,SMG1,SMG2,SM11,SM12,SM14	
						SM21,SM22,SM24,SX,SXE4,SXU,SX4,TX,TXE,TXU,TXU1,TX2,TX4,UX,VEE1	
						VEN1,VES1,VMG1,VNG4,VSD,VSD7,VX,VXU,VXU1,VX2,VX4	
			1	-	-	1383993 QAB2	
			(1)	-	-	RMG2,VSD1	
			-	1	1		
	18310-Z8K-870	MUFFLER COMP. (SILENT)	1	-	-	QX7,SX7,VSD7	
3	18315-ZE1-000	STAY, MUFFLER	1	-	-	HX,HXQ,HXU,HX2,HX26,HX4,LD,LDB1,LDB2,LDN,LD4,LH,LHB2,LHP1,LHQ4,LJ	
						LJC1,LJG,LSJ,LX,LX2,LX4,NAX,NAX1,NDF1,NDJ,NJ,NJG,NMB,NTB,NW,NWA	
						NWB2,NX,PMX,PX,PXU,PX2,QA,QAB2,QA2,QD,QG,QG2,QH,QHP1,QHQ4,QH26	
						QH4,QJF,QM,QSW4,QT,QTP,QTP2,QX,QXB2,QXC,QXC9,QXE,QXE2,QXE4,QXE6	
						QXE8,QXF,QXF2,QXH4,QXQ,QXS2,QXU,QX2,QX26,QX4,QX7,RG,RH,RHA2,RHQ4	
						RH2,RH26,RMG2,RX,RXU,RX2,RX4,SD,SDB1,SDB2,SDN,SD4,SH,SHQ4,SJ,SJG	
						SMC4,SM11,SM12,SM14,SM21,SM22,SM24,SX,SXE4,SXU,SX4,SX7,TX,TXE,TXU	
						TXU1,TX2,TX4,UX,VA2,VEE1,VEN1,VES1,VGG2,VMG1,VNG4,VSD,VSD7,VX,VXU	
						VXU1,VX2,VX4	
			-	1	1		

Ref. No.	Part No.	Description	Reqd. QTY			Serial No.	Parts catalogue code
			(1)	GX200 (2)	(3)		
4	18320-ZF1-H51	PROTECTOR, MUFFLER (SILENT)	1	-	-		HX, HXQ, HXU, HX2, HX26, HX4, LD, LDB1, LDB2, LDN, LD4, LH, LHB2, LHP1, LHQ4, LJ, LJC1, LJG, LSJ, LX, LX2, LX4, NAX, NAX1, NDF1, NDJ, NJ, NJG, NMB, NTB, NW, NWA, NWB2, NX, PMX, PX, PXU, PX2, QA, QAB2, QA2, QD, QG, QG2, QH, QHP1, QHQ4, QH26, QH4, QJF, QM, QSW4, QT, QTP, QTP2, QX, QXB2, QXC, QXC9, QXE, QXE2, QXE4, QXE6, QXE8, QXF, QXF2, QXH4, QXQ, QXS2, QXU, QX2, QX26, QX4, QX7, RG, RH, RHA2, RHQ4, RH2, RH26, RMG2, RX, RXU, RX2, RX4, SD, SDB1, SDB2, SDN, SD4, SH, SHQ4, SJ, SJG, SMC4, SMG1, SMG2, SM11, SM12, SM14, SM21, SM22, SM24, SX, SXE4, SXU, SX4, SX7, TX, TXE, TXU, TXU1, TX2, TX4, UX, VA2, VEE1, VEN1, VES1, VGG2, VMG1, VNG4, VSD, VSD7, VX, VXU, VXU1, VX2, VX4
5	18331-883-810	CAP, MUFFLER	1	-	-		NAX, NAX1, NDF1, NDJ, NMB, NTB, NW, NWA, QA, QA2, QT, QTP, QXC, QXC9, SM11, SM12, SM14, SM21, SM22, SM24
			1	-	-	1113369	VEE1
			1	-	-	1383992	QAB2
6	18355-ZL0-000	ARRESTER, SPARK	1	-	-		QA, QA2, QG2, QH4, QXH4, RMG2, VA2, VGG2
			1	-	-	1383992	QAB2
			(1)	-	-		HX, HXQ, HXU, HX2, HX26, HX4, LX, LX2, LX4, NX, PMX, PX, PXU, PX2, QSW4, QX, QXB2, QXE, QXE2, QXE4, QXE6, QXE8, QXF, QXF2, QXQ, QXS2, QXU, QX2, QX26, QX4, QX7, RG, RH, RHA2, RHQ4, RH2, RH26, RX2, SM12, SM22, SXE4, TX, TXE, TXU, TXU1, TX2, TX4, VNG4, VSD, VSD1, VSD7, VX, VXU, VXU1, VX2, VX4
7	18361-ZL0-000	NETTING, WIRE FLANGE	-	(1)	-		
			1	-	-		HX, HXQ, HXU, HX2, HX26, HX4, LD, LDB1, LDB2, LDN, LD4, LH, LHB2, LHP1, LHQ4, LJ, LJC1, LJG, LSJ, LX, LX2, LX4, NAX, NAX1, NDF1, NDJ, NJ, NJG, NMB, NTB, NW, NWA, NWB2, NX, PMX, PX, PXU, PX2, QD, QG, QH, QHP1, QHQ4, QH26, QJF, QM, QSW4, QT, QTP, QTP2, QX, QXB2, QXC, QXC9, QXE, QXE2, QXE4, QXE6, QXE8, QXF, QXF2, QXQ, QXS2, QXU, QX2, QX26, QX4, QX7, RG, RH, RHA2, RHQ4, RH2, RH26, RX, RXU, RX2, RX4, SD, SDB1, SDB2, SDN, SD4, SH, SHQ4, SJ, SJG, SMC4, SMG1, SMG2, SM11, SM12, SM14, SM21, SM22, SM24, SX, SXE4, SXU, SX4, SX7, TX, TXE, TXU, TXU1, TX2, TX4, UX, VEE1, VEN1, VES1, VMG1, VNG4, VSD, VSD7, VX, VXU, VXU1, VX2, VX4
			1	-	-	1383993	QAB2
8	18381-ZH8-800	GASKET, MUFFLER	-	1	1		
			1	-	-		HX, HXQ, HXU, HX2, HX26, HX4, LD, LDB1, LDB2, LDN, LD4, LH, LHB2, LHP1, LHQ4, LJ, LJC1, LJG, LSJ, LX, LX2, LX4, NAX, NAX1, NDF1, NDJ, NJ, NJG, NMB, NTB, NTU, NW, NWA, NWB2, NX, PMX, PX, PXU, PX2, QA, QAB2, QA2, QD, QG, QG2, QH, QHP1, QHQ4, QH26, QH4, QJF, QM, QSW4, QT, QTP, QTP2, QX, QXB2, QXC, QXC9, QXE, QXE2, QXE4, QXE6, QXE8, QXF, QXF2, QXH4, QXQ, QXS2, QXU, QX2, QX26, QX4, QX7, RG, RH, RHA2, RHQ4, RH2, RH26, RMG2, RX, RXU, RX2, RX4, SD, SDB1, SDB2, SDN, SD4, SH, SHQ4, SJ, SJG, SMC4, SMG1, SMG2, SM11, SM12, SM14, SM21, SM22, SM24, SX, SXE4, SXU, SX4, SX7, TX, TXE, TXU, TXU1, TX2, TX4, UX, VA2, VEE1, VEN1, VES1, VGG2, VMG1, VNG4, VSD, VSD7, VX, VXU, VXU1, VX2, VX4
9	18433-ZH8-W40	COVER COMP., MUFFLER	-	1	1		
			(1)	(1)	-		HX4, LD4, LHQ4, LX4, QG, QHQ4, QSW4, QXE4, QX4, QX7, RG, RHQ4, RX4, SD4, SHQ4, SMC4, SM14, SM24, SXE4, SX4, SX7, TX4, VNG4, VSD, VSD1, VSD2, VSD7, VX4, VX4P
10	18434-ZH8-W40	COVER COMP., MUFFLER RR.	(1)	(1)	-		HX4, LD4, LHQ4, LX4, QG, QHQ4, QSW4, QXE4, QX4, QX7, RG, RHQ4, RX4, SD4, SHQ4, SMC4, SM14, SM24, SXE4, SX4, SX7, TX4, VNG4, VSD, VSD1, VSD2, VSD7, VX4, VX4P
11	18436-ZH8-W40	BASE COMP., MUFFLER COVER	(1)	(1)	-		HX4, LD4, LHQ4, LX4, QG, QHQ4, QSW4, QXE4, QX4, QX7, RG, RHQ4, RX4, SD4, SHQ4, SMC4, SM14, SM24, SXE4, SX4, SX7, TX4, VNG4, VSD, VSD1, VSD2, VSD7, VX4, VX4P
12	18466-ZH8-W40	SPACER, MUFFLER COVER	(3)	(3)	-		HX4, LD4, LHQ4, LX4, QG, QHQ4, QSW4, QXE4, QX4, QX7, RG, RHQ4, RX4, SD4, SHQ4, SMC4, SM14, SM24, SXE4, SX4, SX7, TX4, VNG4, VSD, VSD1, VSD2, VSD7, VX4, VX4P



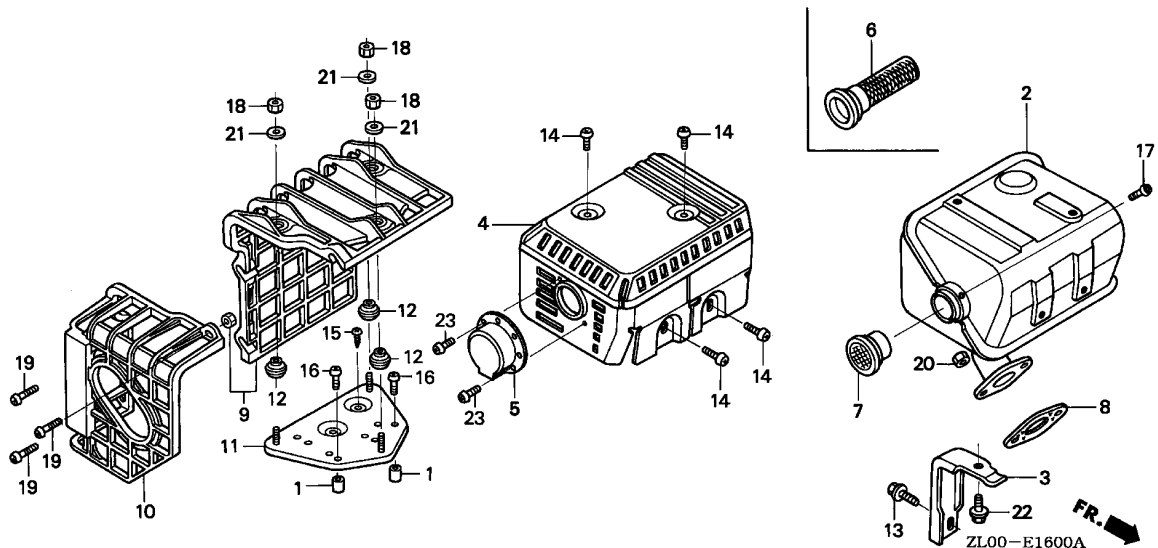

Ref. No.	Part No.	Description	Reqd. QTY			Serial No.	Parts catalogue code
			(1)	(2)	(3)		
13	90016-ZE1-000	BOLT, FLANGE, 6X13(CT200) ...	1	-	-	HX, HXQ, HXU, HX2, HX26, HX4, LD, LDB1, LDB2, LDN, LD4, LH, LHB2, LHP1, LHQ4, LJ LJC1, LJG, LSJ, LX, LX2, LX4, NAX, NAX1, NDF1, NDJ, NJ, NJG, NMB, NTB, NW, NWA, NWB2, NX, PMX, PX, PXU, PX2, QA, QAB2, QA2, QD, QG, QG2, QH, QHP1, QHQ4, QH26, QH4, QJF, QM, QSW4, QT, QTP, QTP2, QX, QXB2, QXC, QXC9, QXE, QXE2, QXE4, QXE6, QXE8, QXF, QXF2, QXH4, QXQ, QXS2, QXU, QX2, QX26, QX4, QX7, RG, RH, RHA2, RHQ4, RH2, RH26, RMG2, RX, RXU, RX2, RX4, SD, SDB1, SDB2, SDN, SD4, SH, SHQ4, SJ, SJG, SMC4, SM11, SM12, SM14, SM21, SM22, SM24, SX, SXE4, SXU, SX4, SX7, TX, TXE, TXU, TXU1, TX2, TX4, UX, VA2, VEE1, VEN1, VES1, VGG2, VMG1, VNG4, VSD, VSD7, VX, VXU, VXU1, VX2, VX4	
14	90050-ZE1-000	SCREW, TAPPING, 5X8	4	1	1	HX, HXQ, HXU, HX2, HX26, HX4, LD, LDB1, LDB2, LDN, LD4, LH, LHB2, LHP1, LHQ4, LJ LJC1, LJG, LSJ, LX, LX2, LX4, NAX, NAX1, NDF1, NDJ, NJ, NJG, NMB, NTB, NW, NWA, NWB2, NX, PMX, PX, PXU, PX2, QA, QAB2, QA2, QD, QG, QG2, QH, QHP1, QHQ4, QH26, QH4, QJF, QM, QSW4, QT, QTP, QTP2, QX, QXB2, QXC, QXC9, QXE, QXE2, QXE4, QXE6, QXE8, QXF, QXF2, QXH4, QXQ, QXS2, QXU, QX2, QX26, QX4, QX7, RG, RH, RHA2, RHQ4, RH2, RH26, RMG2, RX, RXU, RX2, RX4, SD, SDB1, SDB2, SDN, SD4, SH, SHQ4, SJ, SJG, SMC4, SMG1, SMG2, SM11, SM12, SM14, SM21, SM22, SM24, SX, SXE4, SXU, SX4, SX7, TX, TXE, TXU, TXU1, TX2, TX4, UX, VA2, VEE1, VEN1, VES1, VGG2, VMG1, VNG4, VSD, VSD7, VX, VXU, VXU1, VX2, VX4	
15	90050-ZE1-000	SCREW, TAPPING, 5X8	(1)	4	4	HX4, LD4, LHQ4, LX4, QG, QHQ4, QSW4, QXE4, QX4, QX7, RG, RHQ4, RX4, SD4, SHQ4, SMC4, SM14, SM24, SXE4, SX4, SX7, TX4, VNG4, VSD, VSD1, VSD2, VSD7, VX4, VX4P	
16	90050-ZH8-W40	SCREW, TAPPING, 5X25	(2)	(2)	-	HX4, LD4, LHQ4, LX4, QG, QHQ4, QSW4, QXE4, QX4, QX7, RG, RHQ4, RX4, SD4, SHQ4, SMC4, SM14, SM24, SXE4, SX4, SX7, TX4, VNG4, VSD, VSD1, VSD2, VSD7, VX4, VX4P	
17	90055-ZE1-000	SCREW, TAPPING, 4X6	(1)	1	-	HXQ, HX4, LD, LDB1, LDB2, LDN, LD4, LSJ, LX, NAX, NAX1, NWA, NWB2, PX2, QA, QA2, QG, QSW4, QT, QXE, QXF, QXF2, QXQ, RG, SDB1, SDN, TXE, TX4, UX, VA2, VNG4, VX4P, QXE8, QX7, VSD1, VSD7	

Ref. No.	Part No.	Description	Reqd. QTY			Serial No.	Parts catalogue code
			(1)	GX200 (2)	(3)		
17)	90056-ZL0-000	SCREW, TAPPING, 4X6	1	1	-	-----	HX, HXU, HX2, HX26, LH, LHB2, LHP1, LHQ4, LJ, LJC1, LJG, LX2, LX4, NDF1, NDJ, NJ, NJG, NMB, NTB, NW, NX, PMX, PX, PXU, QAB2, QD, QG2, QH, QHP1, QHQ4, QH26, QH4, QJF, QM, QTP, QTP2, QX, QXB2, QXC, QXC9, QXE2, QXE4, QXE6, QXE8, QXH4, QXS2, QXU, QX2, QX26, QX4, QX7, RH, RHA2, RHQ4, RH2, RH26, RMG2, RX, RXU, RX2, RX4, SD, SDB2, SD4, SH, SHQ4, SJ, SJG, SMC4, SMG1, SMG2, SM11, SM12, SM14, SM21, SM22, SM24, SX, SXE4, SXU, SX4, SX7, TX, TXU, TXU1, TX2, VEE1, VEN1, VES1, VGG2, VMG1, VSD, VSD7, VX, VXP, VXU, VXU1, VX2, VX4
18	90302-KF9-900	NUT, HEX., 5MM	-	-	1	-----	HX4, LD4, LHQ4, LX4, QG, QHQ4, QSW4, QXE4, QX4, QX7, RG, RHQ4, RX4, SD4, SHQ4, SMC4, SM14, SM24, SXE4, SX4, SX7, TX4, VNG4, VSD, VSD1, VSD2, VSD7, VX4, VX4P
19	93891-06020-07	SCREW-WASHER, 6X20	(3)	(3)	-	-----	HX4, LD4, LHQ4, LX4, QG, QHQ4, QSW4, QXE4, QX4, QX7, RG, RHQ4, RX4, SD4, SHQ4, SMC4, SM14, SM24, SXE4, SX4, SX7, TX4, VNG4, VSD, VSD1, VSD2, VSD7, VX4, VX4P
20	94001-08000-0S	NUT, HEX., 8MM	2	-	-	-----	HX, HXQ, HXU, HX2, HX26, HX4, LD, LDB1, LDB2, LDN, LD4, LH, LHB2, LHP1, LHQ4, LJ, LJC1, LJG, LSJ, LX, LX2, LX4, NAX, NAX1, NDF1, NDJ, NJ, NJG, NMB, NTB, NW, NWA, NWB2, NX, PMX, PX, PXU, PX2, QA, QAB2, QA2, QD, QG, QG2, QH, QHP1, QHQ4, QH26, QH4, QJF, QM, QSW4, QT, QTP, QTP2, QX, QXB2, QXC, QXC9, QXE, QXE2, QXE4, QXE6, QXE8, QXF, QXF2, QXH4, QXQ, QXS2, QXU, QX2, QX26, QX4, QX7, RG, RH, RHA2, RHQ4, RH2, RH26, RMG2, RX, RXU, RX2, RX4, SD, SDB1, SDB2, SDN, SD4, SH, SHQ4, SJ, SJG, SMC4, SMG1, SMG2, SM11, SM12, SM14, SM21, SM22, SM24, SX, SXE4, SXU, SX4, SX7, TX, TXE, TXU, TXU1, TX2, TX4, UX, VA2, VEE1, VEN1, VES1, VGG2, VMG1, VNG4, VSD, VSD7, VX, VXU, VXU1, VX2, VX4
			-	2	2		
21	94103-05700	WASHER, PLAIN, 5MM	(3)	(3)	-	-----	HX4, LD4, LHQ4, LX4, QG, QHQ4, QSW4, QXE4, QX4, QX7, RG, RHQ4, RX4, SD4, SHQ4, SMC4, SM14, SM24, SXE4, SX4, SX7, TX4, VNG4, VSD, VSD1, VSD2, VSD7, VX4, VX4P
22	95701-06012-00	BOLT, FLANGE, 6X12	1	-	-	-----	HX, HXQ, HXU, HX2, HX26, HX4, LD, LDB1, LDB2, LDN, LD4, LH, LHB2, LHP1, LHQ4, LJ, LJC1, LJG, LSJ, LX, LX2, LX4, NAX, NAX1, NDF1, NDJ, NJ, NJG, NMB, NTB, NW, NWA, NWB2, NX, PMX, PX, PXU, PX2, QA, QAB2, QA2, QD, QG, QG2, QH, QHP1, QHQ4, QH26, QH4, QJF, QM, QSW4, QT, QTP, QTP2, QX, QXB2, QXC, QXC9, QXE, QXE2, QXE4, QXE6, QXE8, QXF, QXF2, QXH4, QXQ, QXS2, QXU, QX2, QX26, QX4, QX7, RG, RH, RHA2, RHQ4, RH2, RH26, RMG2, RX, RXU, RX2, RX4, SD, SDB1, SDB2, SDN, SD4, SH, SHQ4, SJ, SJG, SMC4, SMG1, SMG2, SM11, SM12, SM14, SM21, SM22, SM24, SX, SXE4, SXU, SX4, SX7, TX, TXE, TXU, TXU1, TX2, TX4, UX, VA2, VEE1, VEN1, VES1, VGG2, VMG1, VNG4, VSD, VSD7, VX, VXU, VXU1, VX2, VX4
23	90055-ZE1-000	SCREW, TAPPING, 4X6	-	1	1	-----	NAX, NAX1, NDF1, NDJ, NMB, NTB, NW, NWA, QA, QA2, QT, QTP, QXC, QXC9, SM11, SM12, SM14, SM21, SM22, SM24
			2	-	-	-----	1113369 VEE1
			2	-	-	-----	1383992 QAB2



E-16-1

MUFFLER(2)

H11

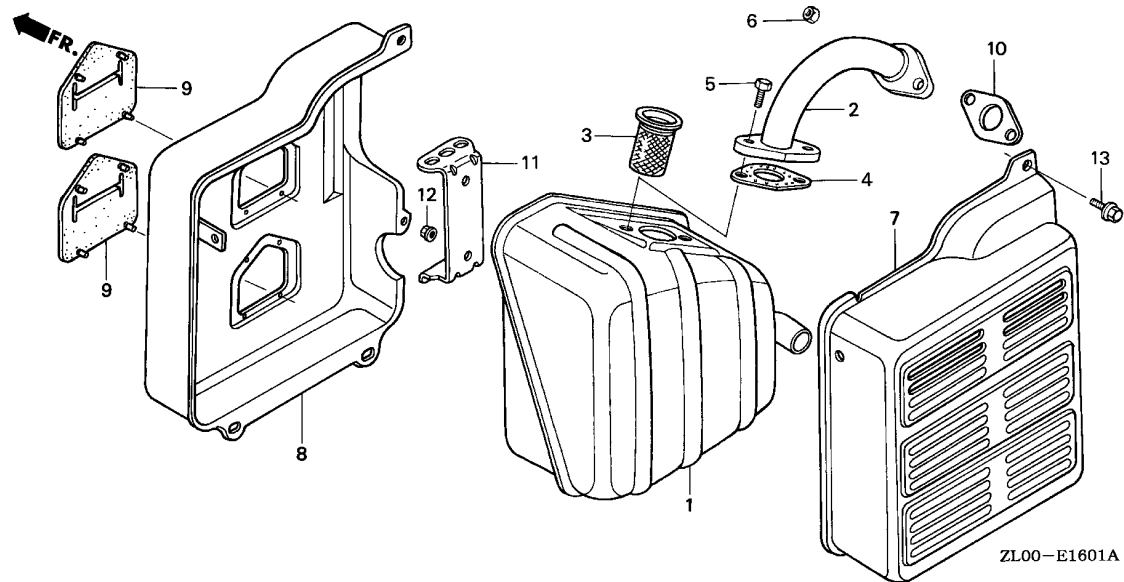

Ref. No.	L.O.N.	(Relative ref. Number) Description	F.R.T.
1	3131C5	MUFFLER, EXHAUST	0.2
2	3131C9	PIPE, EXHAUST	0.2
3	3131A1	ARRESTER, SPARK	0.2
4		(10)	
	3131B4	GASKET, EXHAUST MUFFLER	0.2
8	3131D8	PROTECTOR, EXHAUST MUFFLER :INNER	0.2
9	3131G6	SEAL, MUFFLER PROTECTOR	0.2

Ref. No.	Part No.	Description	Reqd. QTY			Serial No.	Parts catalogue code
			(1)	(2)	(3)		
1	18310-ZB3-C00	MUFFLER COMP.	1	-	-	VAA,VAA1,VEN,VEN4,VES,VMT,VSD1,VS17	
2	18330-ZB2-000	PIPE COMP., EX.	1	-	-	VAA,VAA1,VES,VMT,VSD1,VS17	
3	18355-898-630	ARRESTER, SPARK	1	-	-	VSD1,VS17	
4	18381-ZE1-800	GASKET, MUFFLER	1	-	-	VAA,VAA1,VEN,VEN4,VES,VMT,VSD1,VS17	
5	92101-08020-0A	BOLT, HEX., 8X20	2	-	-	VAA,VAA1,VEN,VEN4,VES,VMT,VSD1,VS17	
6	94001-08000-0S	NUT, HEX., 8MM	2	-	-	VAA,VAA1,VEN4,VMT,VSD1,VSD2,VS17	
7	18320-ZL0-V30	PROTECTOR, MUFFLER OUTER	1	-	-	1044773 VEN	
	18320-ZB2-000	1	-	-	1033572 VEN	
			1	-	-	VAA,VAA1,VEN4,VES,VMT	
8	18325-ZB2-000	PROTECTOR, MUFFLER INNER	1	-	-	1033573 VEN	
	18325-ZL0-V30	1	-	-	1033572 VEN	
	18325-ZH8-T90	PROTECTOR, MUFFLER INNER (DENYO)	1	-	-	VAA,VAA1,VEN4,VES	
			1	-	-	1033573 VEN	
9	18329-ZB2-000	SEAL, MUFFLER PROTECTOR	2	-	-	VAA,VAA1,VEN,VEN4,VES,VMT	
10	18381-ZH8-800	GASKET, MUFFLER	1	-	-	VAA,VAA1,VEN,VEN4,VES,VMT,VSD1,VSD2,VS17	
11	18338-ZB3-E30	STAY, MUFFLER	1	-	-	VAA,VAA1,VMT	
12	94050-06000	NUT, FLANGE, 6MM	2	-	-	VAA1,VMT	
13	95701-06012-00	BOLT, FLANGE, 6X12	5	-	-	VAA,VAA1,VMT	
			5	-	-	1047969 VEN	

E-16-2

MUFFLER(3)(BL/LVL/QVL)

H12

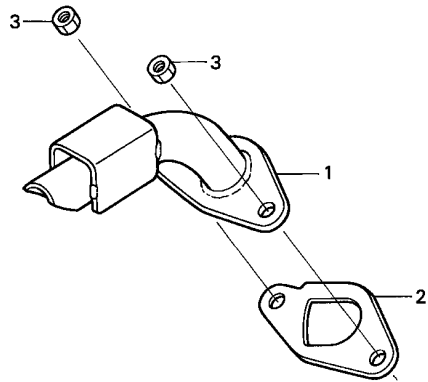

ZL00-E1602A

Ref. No.	L.O.N.	(Relative ref. Number) Description	F.R.T.
1	3131G1	PIPE, EXHAUST(A)	0.1
2	3131H1	GASKET, EXHAUST MUFFLER(A) ...	0.1

Ref. No.	Part No.	Description	Reqd. QTY			Serial No.	Parts catalogue code
			(1)	GX200 (2)	(3)		
1	18310-ZL0-W80	PIPE, EX.	1	-	-	-----	BL,LVL,QVL
2	18381-ZH8-800	GASKET, MUFFLER	1	-	-	-----	BL,LVL,QVL
3	94001-08000-0S	NUT, HEX., 8MM	2	-	-	-----	BL,LVL,QVL



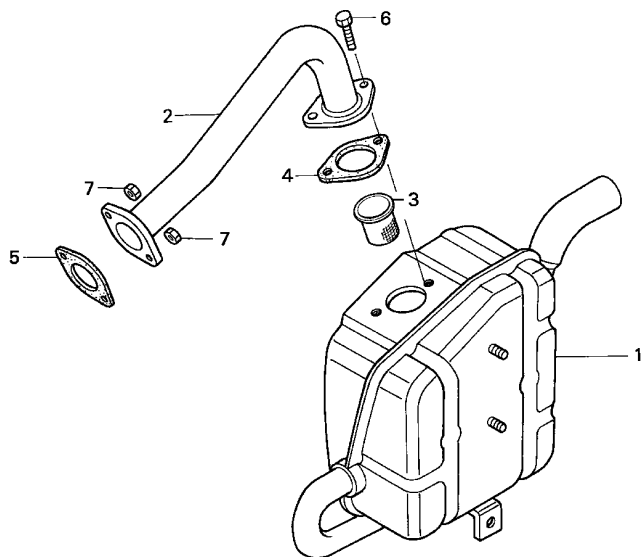

ZL00-E1603A

Ref. No.	L.O.N.	(Relative ref. Number) Description	F.R.T.
1	3131C5	MUFFLER, EXHAUST	0.2
2	3131C9	PIPE, EXHAUST	0.2
3	3131A1	ARRESTER, SPARK	0.2
4	3131B4	(5) GASKET, EXHAUST MUFFLER	0.2

Ref. No.	Part No.	Description	Reqd. QTY			Serial No.	Parts catalogue code
			(1)	GX200 (2)	(3)		
1	18310-ZB6-C01	MUFFLER COMP.	1	-	-	----- NJC1,QJF1	
2	18330-ZB6-000	PIPE COMP., EX.	1	-	-	----- NJC1,QJF1	
3	18355-898-630	ARRESTER, SPARK	1	-	-	----- NJC1,QJF1	
4	18381-ZE1-800	GASKET, MUFFLER	1	-	-	----- NJC1,QJF1	
5	18381-ZH8-800	GASKET, MUFFLER	1	-	-	----- NJC1,QJF1	
6	92101-08020-0A	BOLT, HEX., 8X20	2	-	-	----- NJC1,QJF1	
7	94001-08000-0S	NUT, HEX., 8MM	2	-	-	----- NJC1,QJF1	

2

E-17

FUEL TANK(1)

H14

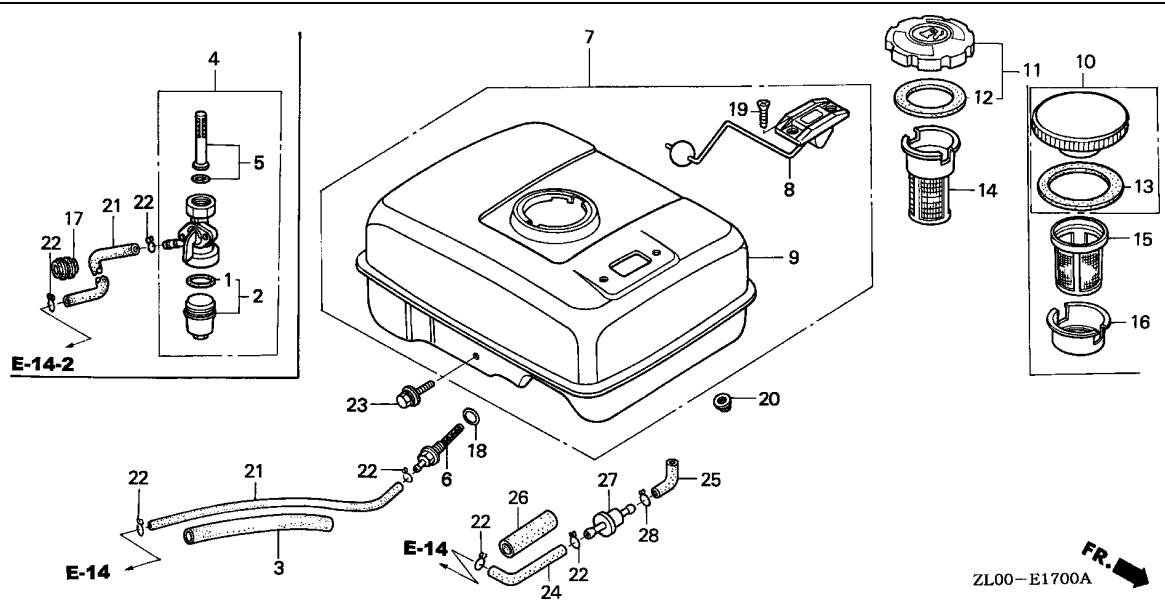

Ref. No.	L.O.N.	(Relative ref. Number) Description	F.R.T.
1	3101C4	PACKING SET, COCK	0.2
4	3101A3	COCK, FUEL	0.2
5	3101D4	SCREEN SET	0.2
6	3101H6	STRAINER, JOINT FUEL	0.2
7		(9)	
8	3101H7	TANK, FUEL	0.2
14	6171A1	METER UNIT, FUEL	0.1
		(15)	
21	3101A6	FILTER, FUEL	0.1
27	3101F1	TUBE, FUEL TANK	0.2
		(24,25)	
	3101H8	STRAINER, FUEL	0.1

Ref. No.	Part No.	Description	Reqd. QTY			Serial No.	Parts catalogue code
			(1)	GX200 (2)	(3)		
1	16080-898-631	PACKING SET, COCK	1	-	-	VEN, VEN4, VES	
2	16081-471-831	CUP, FUEL STRAINER	1	-	-	VEN, VEN4, VES	
3	16854-ZH8-000	RUBBER, SUPPORTER (107MM) ...	1	-	-	BL, HX, HXQ, HXU, HX2, HX26, HX4, LD, LDB1, LDB2, LDN, LD4, LH, LHB2, LHP1, LHQ4, LJ, LJC1, LJG, LSJ, LVL, LX, LX2, LX4, NAX, NAX1, NDF1, NDJ, NJ, NJG, NMB, NTB, NW, NWA, NWB2, NX, PMX, PX, PXU, PX2, QA, QAB2, QA2, QD, QG, QG2, QH, QHP1, QHQ4, QH26, QH4, QJF, QM, QSW4, QT, QTP, QTP2, QVL, QX, QXB2, QXC, QXC9, QXE, QXE2, QXE4, QXE6, QXE8, QXF, QXF2, QXH4, QXQ, QXS2, QXU, QX2, QX26, QX4, QX7, RG, RH, RHQ4, RH2, RH26, RX, RXU, RX2, RX4, SD, SDB1, SDB2, SDN, SD4, SH, SHQ4, SJ, SJG, SMC4, SM11, SM12, SM14, SM21, SM22, SM24, SWG4, SX, SXE4, SXU, SX4, SX7, TX, TXE, TXU, TXU1, TX2, TX4, UX, VA2, VEE1, VEN1, VES1, VGG2, VMG1, VNG4, VSD, VSD1, VSD2, VSD7, VS17, VX, VXU, VXU1, VX2, VX4	
4	16950-898-632	COCK ASSY., FUEL	-	-	1	1732010 VEN, VEN4, VES	
	16950-898-633	1	-	-	1732011 VEN, VEN4, VES	
5	16952-883-005	SCREEN SET	1	-	-	1732010 VEN, VEN4, VES	
	16952-662-731	1	-	-	1732011 VEN, VEN4, VES	
6	16955-ZE1-000	JOINT, FUEL TANK	1	-	-	BL, HX, HXQ, HXU, HX2, HX26, HX4, LD, LDB1, LDB2, LDN, LD4, LH, LHB2, LHP1, LHQ4, LJ, LJC1, LJG, LSJ, LVL, LX, LX2, LX4, NAX, NAX1, NDF1, NDJ, NJ, NJG, NMB, NTB, NW, NWA, NWB2, NX, PMX, PX, PXU, PX2, QA, QAB2, QA2, QD, QG, QG2, QH, QHP1, QHQ4, QH26, QH4, QJF, QM, QSW4, QT, QTP, QTP2, QVL, QX, QXB2, QXC, QXC9, QXE, QXE2, QXE4, QXE6, QXE8, QXF, QXF2, QXH4, QXQ, QXS2, QXU, QX2, QX26, QX4, QX7, RG, RH, RHQ4, RH2, RH26, RX, RXU, RX2, RX4, SD, SDB1, SDB2, SDN, SD4, SH, SHQ4, SJ, SJG, SMC4, SM11, SM12, SM14, SM21, SM22, SM24, SX, SXE4, SXU, SX4, SX7, TX, TXE, TXU, TXU1, TX2, TX4, UX, VA2, VEE1, VEN1, VES1, VMG1, VNG4, VSD, VSD7, VX, VXU, VXU1, VX2, VX4	
7	17500-ZE1-813ZA	TANK ASSY., FUEL (GAUGE)	-	-	1		
	NH31.....	MCKINLEY WHITE	1	-	-	LJG, NAX, NAX1, NJG, NMB, NTB, QJF, QTP2, SJG, VEE1	

2

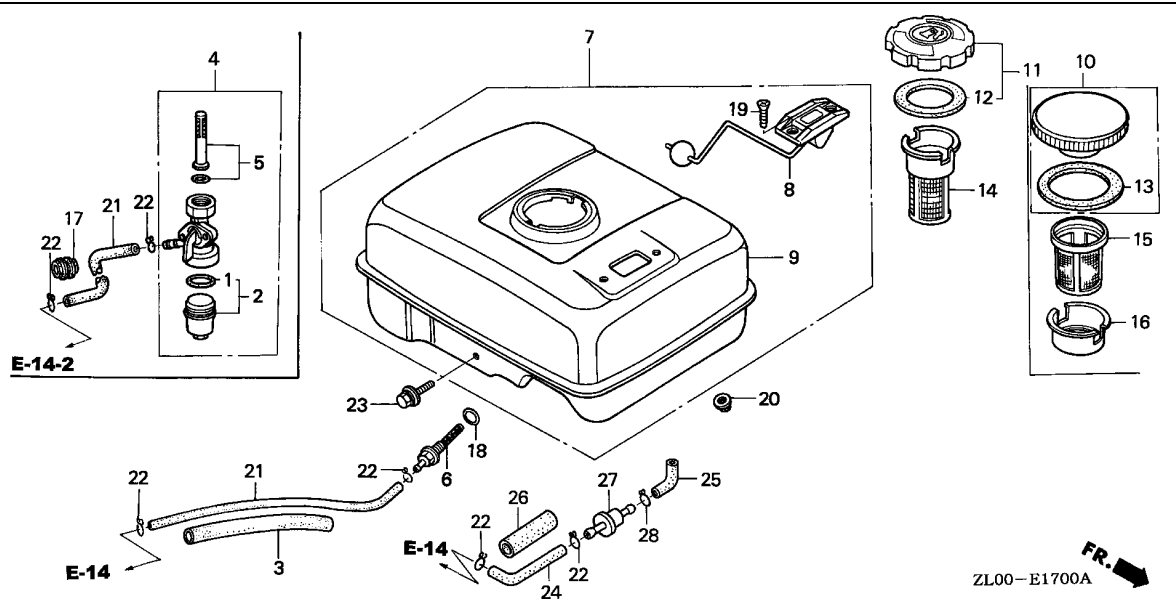

Ref. No.	Part No.	Description	Reqd. QTY			Serial No.	Parts catalogue code
			(1)	(2)	(3)		
(7)	17500-ZE1-813ZC	TANK ASSY., FUEL (GAUGE)	1	-	-		
		NH1.....BLACK	1	-	-		LJG,SJG,VEE1,VEN1
	17500-ZE1-813ZF	*T73*.....EXEN GRAY	1	-	-		VEE1
8	17505-ZE1-013	GAUGE ASSY., FUEL	1	-	-		LJG,NAX,NAX1,NJG,NMB,NTB,QJF,QTP2,SJG,VEE1,VEN1
9	17510-ZE1-020ZA	TANK COMP., FUEL	1	-	-		
		NH31.....MCKINLEY WHITE	1	-	-		BL,HX,HXQ,HXU,HX2,HX26,HX4,LD,LDB1,LDB2,LDN,LD4,LH,LHB2,LHP1,LHQ4,LJ,LJC1,LSJ,LVL,LX,LX2,LX4,NDF1,NDJ,NJ,NW,NA,NWB2,NX,PMX,PX,PXU,PX2,QA,QAB2,QA2,QD,QG,QG2,QH,QHP1,QHQ4,QH26,QH4,QM,QSW4,QT,QTP,QVL,QX,QXB2,QXC,QXC9,QXE,QXE2,QXE4,QXE6,QXE8,QXF,QXF2,QXH4,QXQ,QXS2,QXU,QX2,QX26,QX4,QX7,RG,RH,RHQ4,RH2,RH26,RX,RXU,RX2,RX4,SD,SDB1,SDB2,SDN,SD4,SH,SHQ4,SJ,SMC4,SM11,SM12,SM14,SM21,SM22,SM24,SX,SXE4,SXU,SX4,SX7,TX,TXE,TXU,TXU1,TX2,TX4,UX,VA2,VMG1,VNG4,VSD,VSD7,VX,VXU,VXU1,VX2,VX4
	17510-ZE1-020ZB	*R8*.....BRIGHT RED	1	-	-		LDB2,QAB2,SDB2
			1	-	-	1811701	BL,LHB2
	17510-ZE1-020ZF	*NH1*.....BLACK	1	-	-		HX,HXQ,HXU,HX2,HX4,LD,LD4,LHQ4,LJ,LX,LX2,LX4,NX,PX2,QA,QA2,QD,QHQ4,QM,QT,QXC,QXC9,QXE,QXE2,QXE4,QXF,QXF2,QXQ,QXS2,QX2,RHQ4,RH2,RX,RXU,RX4,SD,SD4,SH,SHQ4,SJ,SM12,SM14,SM22,SM24,SM26,SM28,SM30,SM32,SM34,SM36,SM38,SM40,SM42,SM44,SM46,SM48,SM50,SM52,SM54,SM56,SM58,SM60,SM62,SM64,SM66,SM68,SM70,SM72,SM74,SM76,SM78,SM80,SM82,SM84,SM86,SM88,SM90,SM92,SM94,SM96,SM98,SM100
	17510-ZE1-020ZM	*T38*.....MAT GREEN	1	-	-		VSD
	17510-ZF1-T00ZA	*NH31*.....MCKINLEY WHITE	-	-	1		
	17510-ZE1-020ZN	*R280*.....POWER RED	1	-	-	1811702	BL,LHB2
10	17620-ZE2-W00	CAP COMP., FUEL FILLER (CHROME PLATED)	1	-	-		LDB1,LDB2,NWB2,QT,SDB1
			1	-	-	1812939	BL,LHB2,LJC1,LVL,QAB2,QVL,SDB2,VEE1
	17620-ZE2-W11		1	-	-	1812940	1849430 BL,LHB2,LJC1,LVL,QAB2,QVL,SDB2,VEE1

Ref. No.	Part No.	Description	Reqd. QTY			Serial No.	Parts catalogue code	
			(1)	GX200 (2)	(3)			
11	17620-ZH7-023	CAP COMP., FUEL FILLER (BLACK)	1	-	-	-----	HXQ,HX4,LD,LDN,LD4,LSJ,LX,NAX,NAX1,NDF1,NWA,PMX,PX2,QA,QA2,QG QSW4,QXC,QXE,QXF,QXF2,QXQ,RG,SDN,SD4,TEX,TX4,UX,VA2,VNG4	
			1	-	-	-----	1849430 HX,HXU,HX2,HX26,LH,LHP1,LHQ4,LJ,LJG,LX2,LX4,NDJ,NJ,NJG,NMB,NTB,NW NX,PX,PXU,QD,QG2,QH,QHP1,QHQ4,QH26,QH4,QJF,QM,QTP,QTP2,QX,QXB2 QXC9,QXE2,QXE4,QXE6,QXE8,QXH4,QXS2,QXU,QX2,QX26,QX4,QX7,RH,RHQ4 RH2,RH26,RX,RXU,RX2,RX4,SD,SH,SHQ4,SJ,SJG,SMC4,SM11,SM12,SM14 SM21,SM22,SM24,SX,SXE4,SXU,SX4,SX7,TX,TXU,TXU1,TX2,VEN1,VES1,VMG1 VSD,VSD7,VX,VXU,VXU1,VX2,VX4	
	17620-Z0T-305	CAP COMP., FUEL FILLER (CHROME PLATED)	1	-	-	1849431	-----	BL,HX,HXU,HX2,HX26,LH,LHB2,LHP1,LHQ4,LJ,LJC1,LJG,LVL,LX2,LX4,NDJ NJ,NJG,NMB,NTB,NW,NX,PX,PXU,QAB2,QD,QG2,QH,QHP1,QHQ4,QH26,QH4,QJF QM,QTP,QTP2,QVL,QX,QXB2,QXC9,QXE2,QXE4,QXE6,QXE8,QXH4,QXS2,QXU QX2,QX26,QX4,QX7,RH,RHQ4,RH2,RH26,RX,RXU,RX2,RX4,SD,SDB2,SH,SHQ4 SJ,SJG,SMC4,SM11,SM12,SM14,SM21,SM22,SM24,SX,SXE4,SXU,SX4,SX7,TX TXU,TXU1,TX2,VEE1,VEN1,VES1,VMG1,VSD,VSD7,VX,VXU,VXU1,VX2,VX4
12	17631-ZH7-003	PACKING, FUEL FILLER CAP (39X58X3)	1	-	-	-----	HXQ,HX4,LD,LDN,LD4,LSJ,LX,NAX,NAX1,NDF1,NWA,PMX,PX2,QA,QA2,QG QSW4,QXC,QXE,QXF,QXF2,QXQ,RG,SDN,SD4,TEX,TX4,UX,VA2,VNG4	
			1	-	-	-----	1849430 HX,HXU,HX2,HX26,LH,LHP1,LHQ4,LJ,LJG,LX2,LX4,NDJ,NJ,NJG,NMB,NTB,NW NX,PX,PXU,QD,QG2,QH,QHP1,QHQ4,QH26,QH4,QJF,QM,QTP,QTP2,QX,QXB2 QXC9,QXE2,QXE4,QXE6,QXE8,QXH4,QXS2,QXU,QX2,QX26,QX4,QX7,RH,RHQ4 RH2,RH26,RX,RXU,RX2,RX4,SD,SH,SHQ4,SJ,SJG,SMC4,SM11,SM12,SM14 SM21,SM22,SM24,SX,SXE4,SXU,SX4,SX7,TX,TXU,TXU1,TX2,VEN1,VES1,VMG1 VSD,VSD7,VX,VXU,VXU1,VX2,VX4	
	17631-Z0T-812	PACKING, FUEL FILLER CAP (39X62X3)	1	-	-	1849431	-----	BL,HX,HXU,HX2,HX26,LH,LHB2,LHP1,LHQ4,LJ,LJC1,LJG,LVL,LX2,LX4,NDJ NJ,NJG,NMB,NTB,NW,NX,PX,PXU,QAB2,QD,QG2,QH,QHP1,QHQ4,QH26,QH4,QJF QM,QTP,QTP2,QVL,QX,QXB2,QXC9,QXE2,QXE4,QXE6,QXE8,QXH4,QXS2,QXU QX2,QX26,QX4,QX7,RH,RHQ4,RH2,RH26,RX,RXU,RX2,RX4,SD,SDB2,SH,SHQ4 SJ,SJG,SMC4,SM11,SM12,SM14,SM21,SM22,SM24,SX,SXE4,SXU,SX4,SX7,TX TXU,TXU1,TX2,VEE1,VEN1,VES1,VMG1,VSD,VSD7,VX,VXU,VXU1,VX2,VX4
13	17631-329-003	PACKING, FUEL FILLER CAP (39X58X3)	1	-	-	-----	LDB1,LDB2,NWB2,QT,SDB1	
			1	-	-	-----	1849430 BL,LHB2,LJC1,LVL,QAB2,QVL,SDB2,VEE1	
			-	-	1			
14	17672-ZE2-W01	FILTER, FUEL	1	-	-	-----	BL,LDB2,LDN,LHB2,LJ,LJG,LSJ,LVL,NAX,NAX1,NDF1,NDJ,NJ,NJG,NMB,NTB NW,NWA,NWB2,QA,QAB2,QA2,QJF,QT,QVL,SDB2,SDN,SJ,SJG,SM11,SM12,SM14 SM21,SM22,SM24,VEN1,VES1,VMG1	
			-	-	1			
15	17672-880-000	FILTER, FUEL	1	-	-	-----	QH4,QTP2,QXH4	
	17672-887-791	1	-	-	-----	LJC1,VEE1	
16	17673-893-000	HOLDER, FUEL FILTER	1	-	-	-----	LJC1,QH4,QTP2,QXH4,VEE1	
17	90854-ZB2-000	RUBBER, FUEL (9X15X10)	1	-	-	-----	1110709 VEN	
	90854-ZB3-000	RUBBER, FUEL (9X15X20)	1	-	-	-----	VEN4	
			1	-	-	1110710	-----	VEN
			1	-	-	1345176	-----	VES
18	91353-671-004	O-RING, 14MM(NOK)	1	-	-	-----	BL,HX,HXQ,HXU,HX2,HX26,HX4,LD,LDB1,LDB2,LDN,LD4,LH,LHB2,LHP1,LHQ4 LJ,LJC1,LJG,LSJ,LVL,LX,LX2,LX4,NAX,NAX1,NDF1,NDJ,NJ,NJG,NMB,NTB NW,NWA,NWB2,NX,PMX,PX,PXU,PX2,QA,QAB2,QA2,QD,QG,QG2,QH,QHP1,QHQ4 QH26,QH4,QJF,QM,QSW4,QT,QTP,QTP2,QVL,QX,QXB2,QXC,QXC9,QXE,QXE2 QXE4,QXE6,QXE8,QXF,QXF2,QXH4,QXQ,QXS2,QXU,QX2,QX26,QX4,QX7,RG,RH RHQ4,RH2,RH26,RX,RXU,RX2,RX4,SD,SDB1,SDB2,SDN,SD4,SH,SHQ4,SJ,SJG SMC4,SM11,SM12,SM14,SM21,SM22,SM24,SWG4,SX,SXE4,SXU,SX4,SX7,TX TXE,TXU,TXU1,TX2,TX4,UX,VA2,VEE1,VEN1,VES1,VMG1,VNG4,VSD,VSD7,VX VXU,VXU1,VX2,VX4	
			-	-	1			
19	93600-05010-0A	SCREW, FLAT, 5X10	2	-	-	-----	LJG,NAX,NAX1,NJG,NMB,NTB,QJF,QTP2,SJG,VEE1,VEN1	

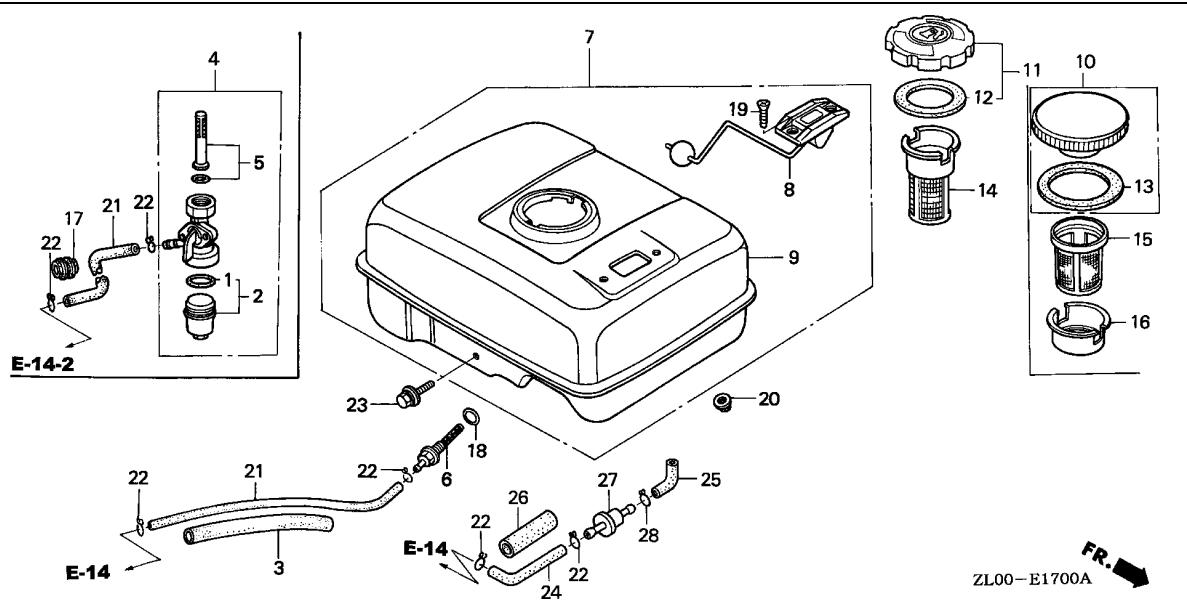

Ref. No.	Part No.	Description	Reqd. QTY			Serial No.	Parts catalogue code
			(1)	(2)	(3)		
20	94050-06000	NUT, FLANGE, 6MM	2	-	-	-----	BL, HX, HXQ, HXU, HX2, HX26, HX4, LD, LDB1, LDB2, LDN, LD4, LH, LHB2, LHP1, LHQ4, LJ, LJC1, LJC, LSJ, LVL, LX, LX2, LX4, NAX, NAX1, NDF1, NDJ, NJ, NJG, NMB, NTB, NW, NWA, NWB2, NX, PMX, PX, PXU, PX2, QA, QAB2, QA2, QD, QG, QG2, QH, QHP1, QHQ4, QH26, QH4, QJF, QM, QSW4, QT, QTP, QTP2, QVL, QX, QXB2, QXC, QXC9, QXE, QXE2, QXE4, QXE6, QXE8, QXF, QXF2, QXH4, QXQ, QXS2, QXU, QX2, QX26, QX4, QX7, RG, RH, RHQ4, RH2, RH26, RX, RXU, RX2, RX4, SD, SDB1, SDB2, SDN, SD4, SH, SHQ4, SJ, SJG, SMC4, SM11, SM12, SM14, SM21, SM22, SM24, SX, SXE4, SXU, SX4, SX7, TX, TXE, TXU, TXU1, TX2, TX4, UX, VA2, VEE1, VEN1, VEN4, VES1, VES4, VES, VES1, VGG2, VMG1, VNG4, VSD, VSD7, VX, VXU, VXU1, VX2, VX4
			-	-	2		
21	95001-45155-40	TUBE, FUEL, 4.5X155 (95001-45001-60M)	1	-	-	-----	1044773 VEN
	95001-45140-40	TUBE, FUEL, 4.5X140 (95001-45001-60M)	1	-	-	-----	BL, HX, HXQ, HXU, HX2, HX26, HX4, LD, LDB1, LDB2, LDN, LD4, LH, LHB2, LHP1, LHQ4, LJ, LJC1, LJC, LSJ, LVL, LX, LX2, LX4, NAX, NAX1, NDF1, NDJ, NJ, NJG, NMB, NTB, NW, NWA, NWB2, NX, PMX, PX, PXU, PX2, QA, QAB2, QA2, QD, QG, QG2, QH, QHP1, QHQ4, QH26, QH4, QJF, QM, QSW4, QT, QTP, QTP2, QVL, QX, QXB2, QXC, QXC9, QXE, QXE2, QXE4, QXE6, QXE8, QXF, QXF2, QXH4, QXQ, QXS2, QXU, QX2, QX26, QX4, QX7, RG, RH, RHQ4, RH2, RH26, RX, RXU, RX2, RX4, SD, SDB1, SDB2, SDN, SD4, SH, SHQ4, SJ, SJG, SMC4, SM11, SM12, SM14, SM21, SM22, SM24, SX, SXE4, SXU, SX4, SX7, TX, TXE, TXU, TXU1, TX2, TX4, UX, VA2, VEE1, VEN1, VEN4, VES1, VES4, VES, VES1, VGG2, VMG1, VNG4, VSD, VSD7, VX, VXU, VXU1, VX2, VX4
			1	-	-	-----	1044774 VEN
			-	-	1		
	95001-45430-40	TUBE, FUEL, 4.5X430 (95001-45001-60M)	1	-	-	-----	VSD1, VSD2, VS17
	95001-45300-40	TUBE, FUEL, 4.5X300 (95001-45001-60M)	1	-	-	-----	SWG4

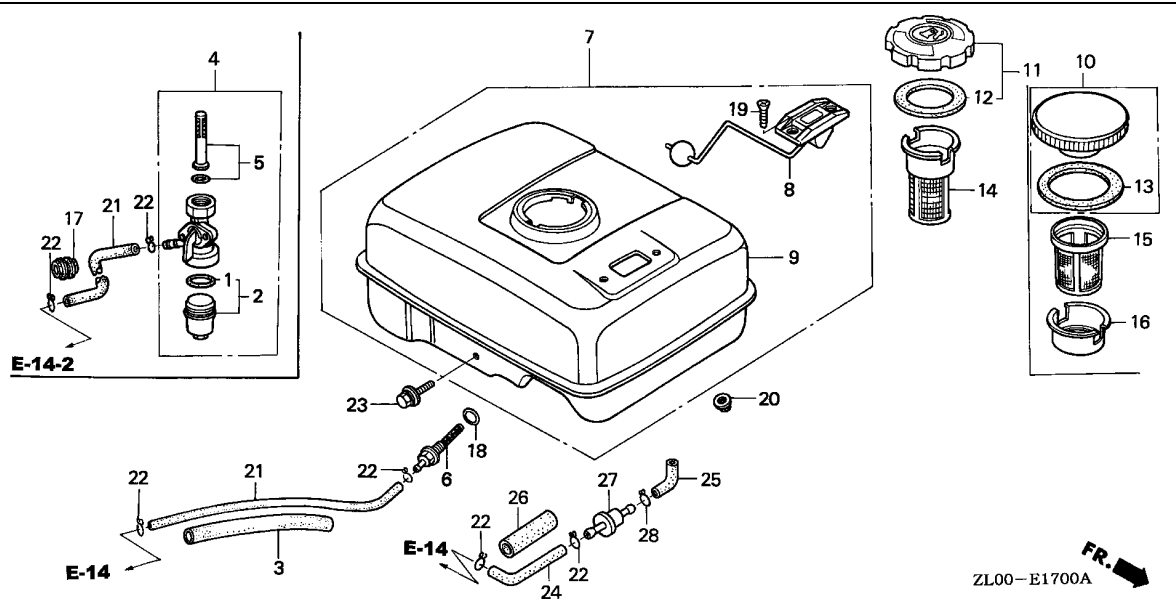

Ref. No.	Part No.	Description	Reqd. QTY			Serial No.	Parts catalogue code
			(1)	(2)	(3)		
22	95002-02080	CLIP, TUBE (B8)	2	-	-		BL, HX, HXQ, HXU, HX2, HX26, HX4, LD, LDB1, LDB2, LDN, LD4, LH, LHB2, LHP1, LHQ4, LJ, LJC1, LJG, LSJ, LVL, LX, LX2, LX4, NAX, NAX1, NDF1, NDJ, NJ, NJG, NMB, NTB, NW, NWA, NWB2, NX, PMX, PX, PXU, PX2, QA, QAB2, QA2, QD, QG, QG2, QH, QHP1, QHQ4, QH26, QH4, QJF, QM, QSW4, QT, QTP, QTP2, QVL, QX, QXB2, QXC, QXC9, QXE, QXE2, QXE4, QXE6, QXE8, QXF, QXF2, QXH4, QXQ, QXS2, QXU, QX2, QX26, QX4, QX7, RG, RH, RHQ4, RH2, RH26, RX, RXU, RX2, RX4, SD, SDB1, SDB2, SDN, SD4, SH, SHQ4, SJ, SJG, SMC4, SMG1, SMG2, SM11, SM12, SM14, SM21, SM22, SM24, SWG4, SX, SXE4, SXU, SX4, SX7, TX, TXE, TXU, TXU1, TX2, TX4, UX, VA2, VEE1, VEN, VEN1, VEN4, VES1, VGG2, VMG1, VNG4, VSD, VSD1, VSD2, VSD7, VS17, VX, VXU, VXU1, VX2, VX4
			2	-	-	1345176	VES
23	90004-ZLO-003	BOLT, FLANGE, 6X34	1	-	-		BL, HX, HXQ, HXU, HX2, HX26, HX4, LD, LDB1, LDB2, LDN, LD4, LH, LHB2, LHP1, LHQ4, LJ, LJC1, LJG, LSJ, LVL, LX, LX2, LX4, NAX, NAX1, NDF1, NDJ, NJ, NJG, NMB, NTB, NW, NWA, NWB2, NX, PMX, PX, PXU, PX2, QA, QAB2, QA2, QD, QG, QG2, QH, QHP1, QHQ4, QH26, QH4, QJF, QM, QSW4, QT, QTP, QTP2, QVL, QX, QXB2, QXC, QXC9, QXE, QXE2, QXE4, QXE6, QXE8, QXF, QXF2, QXH4, QXQ, QXS2, QXU, QX2, QX26, QX4, QX7, RG, RH, RHQ4, RH2, RH26, RX, RXU, RX2, RX4, SD, SDB1, SDB2, SDN, SD4, SH, SHQ4, SJ, SJG, SMC4, SM11, SM12, SM14, SM21, SM22, SM24, SX, SXE4, SXU, SX4, SX7, TX, TXE, TXU, TXU1, TX2, TX4, UX, VA2, VEE1, VEN1, VES1, VMG1, VNG4, VSD, VSD7, VX, VXU, VXU1, VX2, VX4
24	16851-ZE1-000	TUBE A, FUEL	1	-	-		SMG1, SMG2
25	16852-ZE1-000	TUBE B, FUEL	1	-	-		SMG1, SMG2
26	16854-ZH8-810	RUBBER, SUPPORTER (50MM)	1	-	-		SMG1, SMG2
27	16952-952-003	STRAINER, FUEL	1	-	-		SMG1, SMG2
28	95002-02100	CLIP, TUBE (B10)	1	-	-		SMG1, SMG2



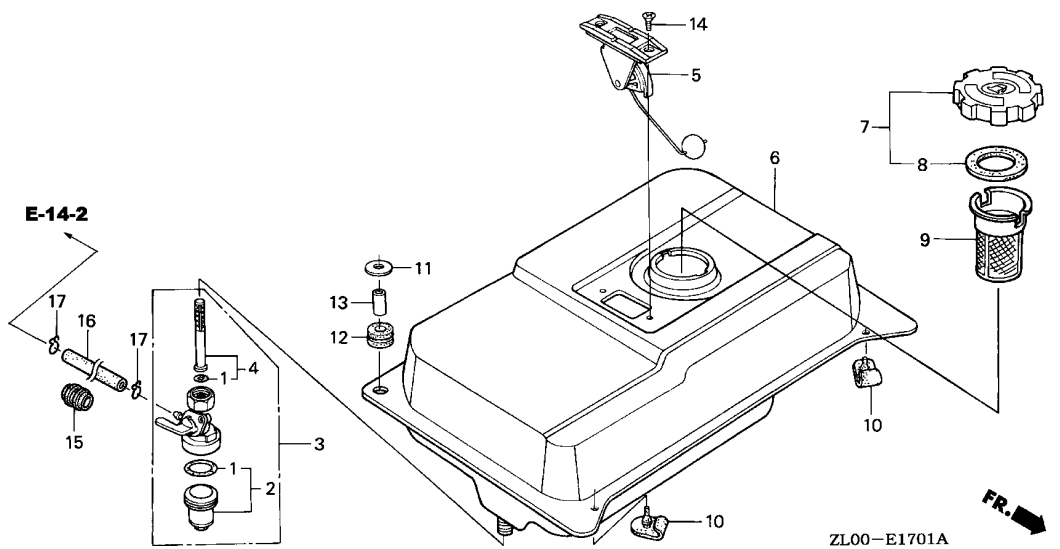

Ref. No.	L.O.N.	(Relative ref. Number) Description	F.R.T.
1	3101C4	PACKING SET, COCK	0.2
3	3101A3	COCK, FUEL	0.2
4	3101D4	SCREEN SET	0.2
5	6171A1	METER UNIT, FUEL	0.1
6	3101H7	TANK, FUEL	0.2
9	3101A6	FILTER, FUEL	0.1
16	3101F2	TUBE, FUEL COCK	0.1

Ref. No.	Part No.	Description	Reqd. QTY			Serial No.	Parts catalogue code
			(1)	(2)	(3)		
1	16080-898-631	PACKING SET, COCK	1	-	-	VAA,VAA1,VMT	
2	16081-471-831	CUP, FUEL STRAINER	1	-	-	VAA,VAA1,VMT	
3	16950-898-632	COCK ASSY., FUEL	1	-	-	VAA,VAA1	
	16950-898-633	1	-	-	1732010 VMT	
4	16952-883-005	SCREEN SET	1	-	-	VMT	
	16952-GG2-731	1	-	-	1732010 VMT	
5	17505-ZB2-003	METER ASSY., FUEL	1	-	-	1732011 VMT	
6	17510-ZB2-000ZB	TANK COMP., FUEL	1	-	-	VAA,VAA1,VMT	
		R8.....BRIGHT RED	1	-	-	VAA,VAA1,VMT	
7	17620-ZH7-023	CAP COMP., FUEL FILLER (BLACK)	1	-	-	VAA,VAA1	
	17620-ZOT-814	CAP COMP., FUEL FILLER	1	-	-	1849430 VMT	
		(CHROME PLATED)	1	-	-	1849431 VMT	
8	17631-ZH7-003	PACKING, FUEL FILLER CAP	1	-	-	VAA,VAA1	
		(39X58X3)	1	-	-	1849430 VMT	
	17631-ZOT-812	PACKING, FUEL FILLER CAP	1	-	-	VMT	
		(39X62X3)	1	-	-	1849431 VMT	
9	17672-ZE2-W01	FILTER, FUEL	1	-	-	VAA,VAA1,VMT	
10	50319-ZB2-000	RUBBER, TANK MOUNTING	2	-	-	VAA,VAA1,VMT	
11	90506-500-000	WASHER, AIR DUCT	2	-	-	VAA,VAA1	
12	90852-898-000	RUBBER, CONTROL BOX	2	-	-	VAA,VAA1,VMT	
13	91552-898-000	COLLAR, CONTROL BOX	2	-	-	VAA,VAA1,VMT	
14	93600-05010-0A	SCREW, FLAT, 5X10	2	-	-	VAA,VAA1,VMT	
15	90854-ZB3-000	RUBBER, FUEL (9X15X20)	1	-	-	VMT	



E-17-1

FUEL TANK(2)(VAA/VAA1/VMT)

14

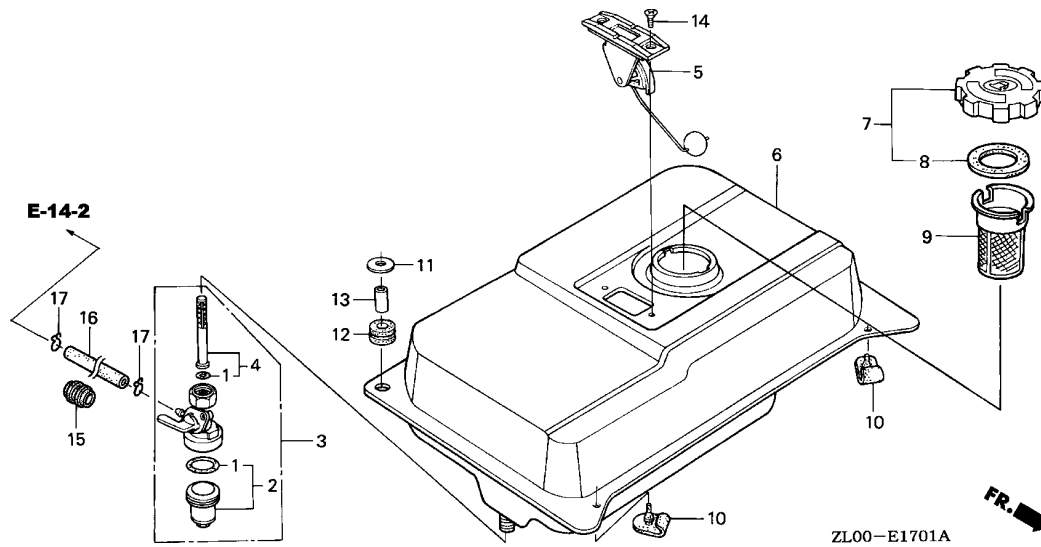

Ref. No.	Part No.	Description	Reqd. QTY			Serial No.	Parts catalogue code
			(1)	GX200 (2)	(3)		
16	95001-45250-40	TUBE, FUEL, 4.5X250 (95001-45001-60M)	1	-	-	----- VMT	
17	95002-02080	CLIP, TUBE (B8)	2	-	-	----- VMT	

2

E-17-2

FUEL TANK(3)(NJC1/QJF1)

15

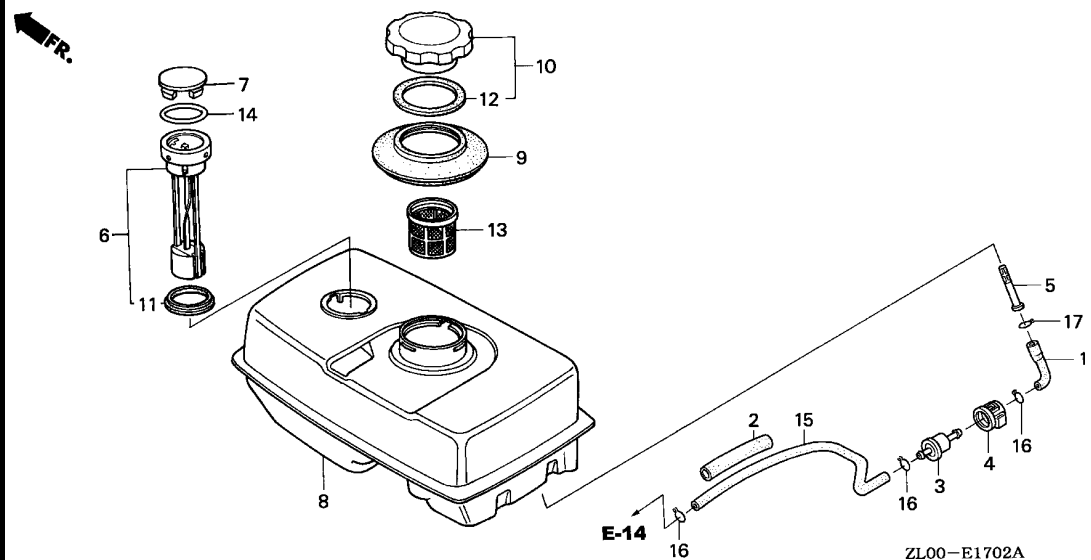

Ref. No.	L.O.N.	(Relative ref. Number) Description	F.R.T.
1	3101F1	TUBE, FUEL TANK	0.2
3	3101H8	STRAINER, FUEL	0.1
5	3101D5	SCREEN, FUEL STRAINER	0.2
6	6171A1	METER UNIT, FUEL	0.1
8	3101H7	TANK, FUEL	0.2
9	4141F1	SEAL, FUEL FILLER NECK	0.1
11	6171A2	PACKING, FUEL METER	0.1
13	3101A6	FILTER, FUEL	0.1
15	3101G0	TUBE, FUEL STRAINER	0.2

2

Ref. No.	Part No.	Description	Reqd. QTY			Serial No.	Parts catalogue code
			(1)	GX200 (2)	(3)		
1	16852-ZB6-000	TUBE, FUEL TANK	1	-	-	NJC1,QJF1	
2	16857-ZB6-000	RUBBER, SUPPORTER	1	-	-	NJC1,QJF1	
3	16910-GB2-005	STRAINER COMP., FUEL	1	-	-	NJC1,QJF1	
4	16915-GB2-000	SUSPENSION, STRAINER	1	-	-	NJC1,QJF1	
5	16952-ZB6-000	BUSH, FUEL PURGE	1	-	-	NJC1,QJF1	
6	17505-898-023	METER COMP., FUEL	1	-	-	NJC1,QJF1	
7	17507-ZA0-800	CAP, FUEL METER	1	-	-	NJC1,QJF1	
8	17510-ZB6-010	TANK COMP., FUEL	1	-	-	NJC1,QJF1	
9	17520-ZA0-800	SEAL, FUEL FILLER NECK	1	-	-	NJC1,QJF1	
10	17620-899-013	CAP COMP., FUEL FILLER	1	-	-	NJC1,QJF1	
11	17624-187-020	PACKING C, FUEL METER	1	-	-	NJC1,QJF1	
12	17631-899-000	PACKING, FUEL FILLER CAP	1	-	-	NJC1,QJF1	
13	17670-ZB6-000	FILTER COMP., FUEL	1	-	-	NJC1,QJF1	
14	91356-706-000	O-RING, 56X2.4	1	-	-	NJC1,QJF1	
15	95001-45300-40	TUBE, FUEL, 4.5X300 (95001-45001-60M)	1	-	-	NJC1	
	95001-45380-40	TUBE, FUEL, 4.5X380 (95001-45001-60M)	1	-	-	QJF1	
16	95002-02080	CLIP, TUBE (B8)	3	-	-	NJC1,QJF1	
17	95002-02100	CLIP, TUBE (B10)	1	-	-	NJC1,QJF1	

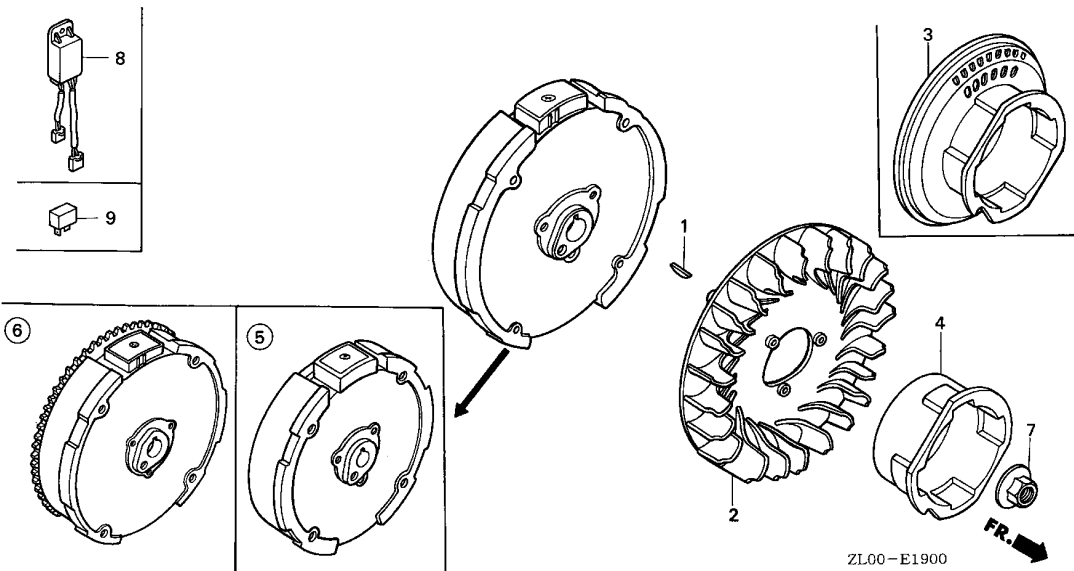

Ref. No.	L.O.N.	(Relative ref. Number) Description	F.R.T.
2	1141G7	FAN, ENGINE COOLING	0.2
4		(3)	
4	1121A9	PULLEY, RECOIL STARTER	0.2
5		(6)	
5	2161B5	FLYWHEEL	0.3
8	6131B7	RECTIFIER, REGULATOR	0.1

Ref. No.	Part No.	Description	Reqd. QTY			Serial No.	Parts catalogue code
			(1)	(2)	(3)		
1	13331-357-000	KEY, SPECIAL WOODRUFF, 25X18	1	1	1		
2	19511-ZE1-000	FAN, COOLING	1	1	1		
3	28450-ZL0-810	PULLEY COMP., STARTER	1	-	-	----- QA,QA2,SMC4	
			1	-	-	1383992 QAB2	
4	28451-ZL0-000	PULLEY, STARTER	1	-	-	----- HX, HXQ, HXU, HX2, HX26, HX4, LD, LDB1, LDB2, LDN, LD4, LH, LHB2, LHP1, LHQ4, LJ, LJC1, LJG, LSJ, LX, LX2, LX4, NAX, NAX1, NDF1, NDJ, NJ, NJC1, NJG, NMB, NTB, NTU, NW, NWA, NWB2, NX, PMX, PX, PXU, PX2, QD, QG, QG2, QH, QHP1, QHQ4, QH26, QH4, QJF, QJF1, QM, QSW4, QT, QTP, QTP2, QX, QXB2, QXC, QXC9, QXE, QXE2, QXE4, QXE6, QXE8, QXF, QXF2, QXH4, QXQ, QXS2, QXU, QX2, QX26, QX4, QX7, RG, RH, RHA2, RHQ4, RH2, RH26, RMG2, RX, RXU, RX2, RX4, SD, SDB1, SDB2, SDN, SD4, SH, SHQ4, SJ, SJG, SMG1, SMG2, SM11, SM12, SM14, SM21, SM22, SM24, SWG4, SX, SXE4, SXU, SX4, SX7, TX, TXE, TXU, TXU1, TX2, TX4, UX, VAA, VAA1, VA2, VEE1, VEN, VEN1, VEN4, VES, VES1, VGG2, VMG1, VMT, VNG4, VSD, VSD1, VSD2, VSD7, VS17, VX, VXU, VXU1, VX2, VX4	
			1	-	-	1383993 ----- QAB2	
	28451-ZH8-003	-----	1	-	-	----- BL	
	28451-ZE1-003	-----	1	-	-	----- LVL, QVL	
5	31100-ZE1-010	FLYWHEEL COMP.	1	-	-	----- QG, RG	
	31100-ZE7-010	FLYWHEEL COMP. (STD.)	1	-	-	----- BL, HX, HXQ, HXU, HX2, HX26, HX4, LD, LDB1, LDB2, LDN, LD4, LH, LHB2, LHP1, LHQ4, LJ, LJC1, LJG, LSJ, LVL, LX, LX2, LX4, NDF1, NDJ, NJ, NJG, NW, NWB2, NX, PMX, PX, PXU, PX2, QA, QAB2, QA2, QD, QH, QHP1, QHQ4, QH26, QJF, QJF1, QM, QT, QVL, QX, QXB2, QXC, QXC9, QXF, QXF2, QXQ, QXU, QX2, QX26, QX4, QX7, RH, RHQ4, RH2, RH26, RX, RXU, RX2, RX4, SD, SDB1, SDB2, SDN, SD4, SH, SHQ4, SJ, SJG, SM11, SM12, SM14, SM21, SM22, SM24, SX, SXU, SX4, SX7, TX, TXU, TX2, TX4, UX, VAA, VAA1, VA2, VEE1, VEN1, VGG2, VMG1, VMT, VNG4, VSD, VSD1, VSD2, VSD7, VS17, VX, VXU, VXU1, VX2, VX4	
			-	1	1		
	31110-ZL0-810	FLYWHEEL COMP. (LAMP)	1	-	-	----- 1080843 RMG2	



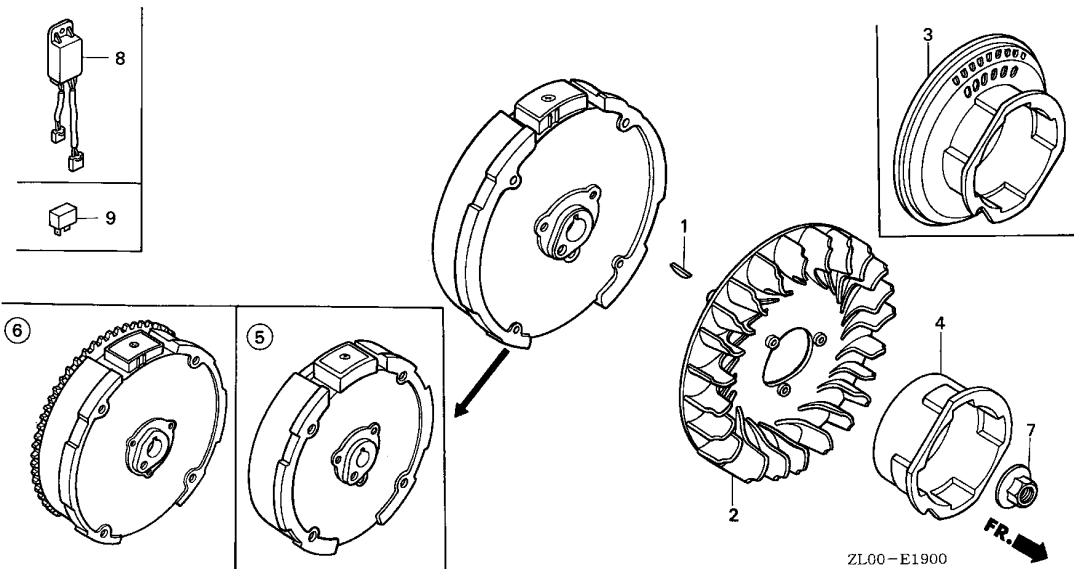

Ref. No.	Part No.	Description	Reqd. QTY			Serial No.	Parts catalogue code
			(1)	GX200 (2)	(3)		
(5)	31110-ZL0-811	FLYWHEEL COMP. (LAMP)	1	-	-	-----	NAX,NTB,NWA,QTP,QXS2,RHA2,SMC4,VEN,VEN4,VES,VES1
			1	-	-	1080844	----- RMG2
6	31110-ZL0-U52	FLYWHEEL COMP. (SEL-7A)	1	-	-	-----	NTU,QG2,QH4,QSW4,QTP2,QXH4
	31110-ZL0-821	FLYWHEEL COMP. (START)	1	-	-	-----	NAX1,NJC1,NMB,QXE,QXE2,QXE4,QXE6,QXE8,SMG1,SMG2,SWG4,SXE4,TXE TXU1
7	90201-878-003	NUT, SPECIAL, 14MM	1	1	1	-----	
8	31600-KE1-010	RECTIFIER COMP., REGULATOR ..	1	-	-	-----	NAX1,NJC1,NMB
9	31700-124-008	RECTIFIER ASSY., SILICON (SHINDENGEN)	1	-	-	-----	SMG1,SMG2

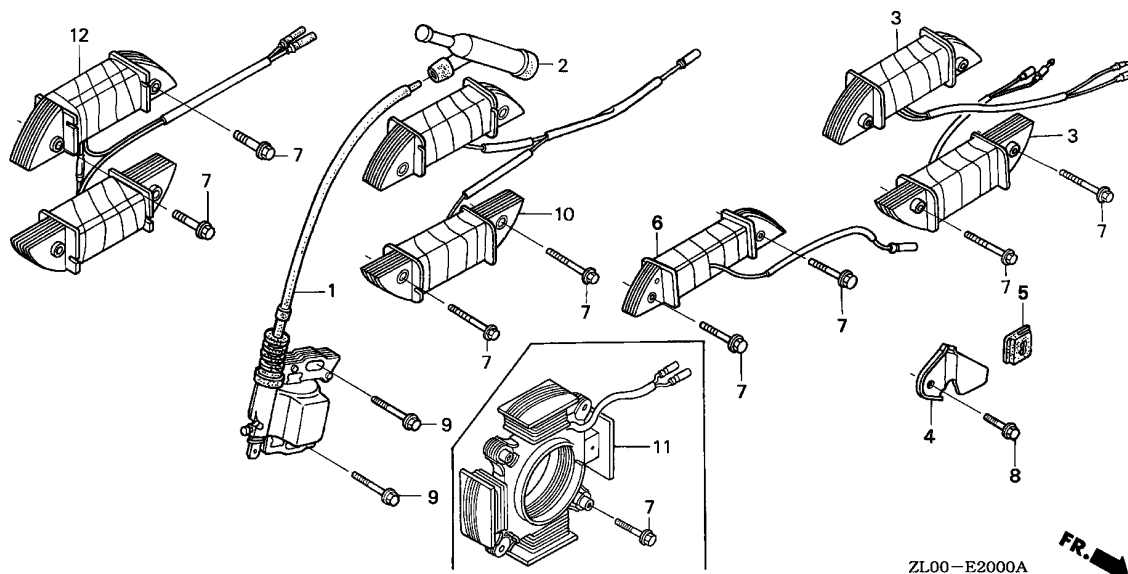

ZL00-E2000A



Ref. No.	L.O.N.	(Relative ref. Number) Description	F.R.T.
1	6141A5	COIL, IGNITION	0.3
2	6141B8	TERMINAL, HIGH TENSION	0.1
10		(3)	
	6141A6	COIL, LAMP	0.3
12		(6,11)	
	6131C3	COIL, CHARGE	0.3

Ref. No.	Part No.	Description	Reqd. QTY			Serial No.	Parts catalogue code
			(1)	GX200 (2)	(3)		
1	30500-ZE1-033	COIL ASSY., IGNITION	1	1	-	BL, HXQ, HXU, HX4, LD, LDB1, LDB2, LDN, LD4, LHP1, LHQ4, LJ, LJC1, LJG, LSJ, LVL, LX4, NAX, NAX1, NDF1, NDJ, NJ, NJC1, NJG, NMB, NTB, NTU, NW, NWA, NNB2, PMX, PXU, PX2, QA, QA2, QD, QG, QG2, QH, QHP1, QHQ4, QH4, QJF, QJF1, QM, QSW4, QT, QTP, QTP2, QVL, QXB2, QXE, QXE4, QXF, QXF2, QXH4, QXQ, QXU, QX4, RG, RHA2, RHQ4, RMG2, RXU, RX4, SD, SDB1, SDN, SD4, SH, SHQ4, SJ, SJG, SMC4, SMG1, SMG2, SM11, SM12, SM14, SM21, SM22, SM24, SXE4, SXU, SX4, TXE, TXU, TXU1, TX4, UX, VAA, VAA1, VA2, VEE1, VEN, VEN4, VES, VES1, VGG2, VMG1, VMT, VNG4, VSD, VSD1, VSD2, VXU, VXU1, VX4, VX4P	
	30500-ZE1-043	1	-	-	1741677 HX, HX2, HX26, LH, LHB2, LX, LX2, NX, PX, QAB2, QH26, QX, QXC, QXC9, QXE2, QXE6, QXS2, QX2, QX26, RH, RH2, RH26, RX, SDB2, SX, TX, TX2, VX, VX2	
			1	-	-	1741678 QXE8, QX7, RX2, SWG4, SX7, VEN1, VSD7, VS17	
			-	-	1	HX, HX2, HX26, LH, LHB2, LX, LX2, NX, PX, QAB2, QH26, QX, QXC, QXC9, QXE2, QXE6, QXS2, QX2, QX26, RH, RH2, RH26, RX, SDB2, SX, TX, TX2, VX, VX2	
2	30600-ZE1-013	TERMINAL ASSY., HIGH TENSION (NICHIWA Y-EZ)	1	-	-	LD, LDB1, LDB2, LDN, LD4, LJ, LJC1, LJG, LSJ, NAX, NAX1, NJ, NJG, NMB, NTB, NTU, NW, NWA, QD, QJF, QJF1, QM, QT, SD, SDB1, SDB2, SDN, SD4, SJ, SJG, SMG1, SMG2, VEN, VES	
			1	-	-	1122110 LHB2, QAB2, VEE1	
			1	-	-	1267448 SM11, SM21, VMG1	
			1	-	-	1383992 BL	
			-	-	1		
	30700-ZB6-013	CAP ASSY., NOISE SUPPRESSOR	1	-	-	NJC1	



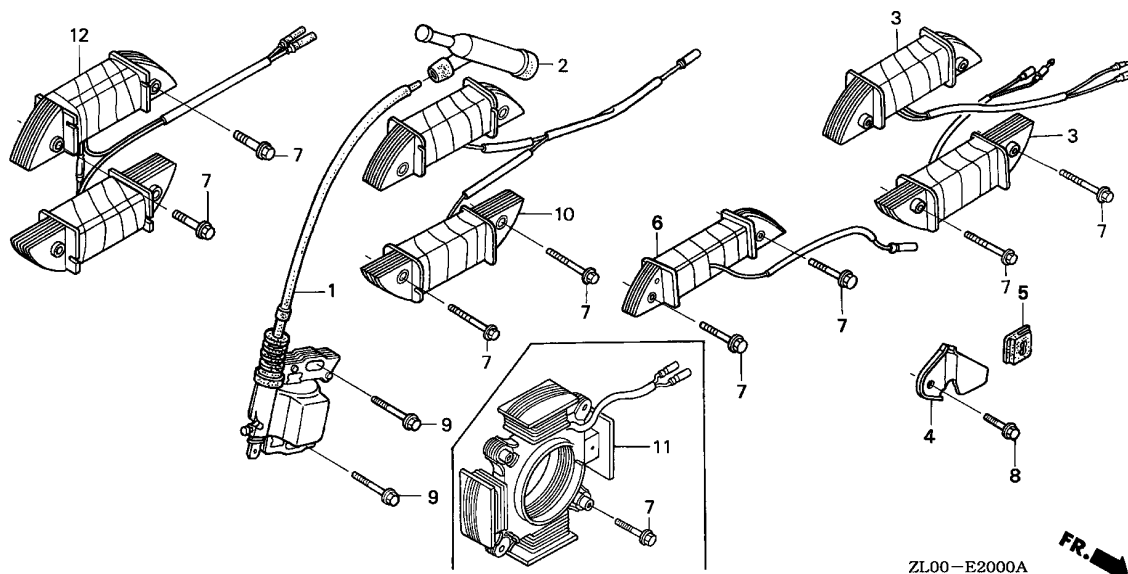

ZL00-E2000A



Ref. No.	Part No.	Description	Reqd. QTY			Serial No.	Parts catalogue code
			(1)	(2)	(3)		
(2)	30700-ZE1-013	CAP ASSY., NOISE SUPPRESSOR (NICHIA Y-EZ RTFM256)	1	-	-	-----	HX, HXQ, HXU, HX2, HX26, HX4, LH, LHP1, LHQ4, LX, LX2, LX4, NDF1, NDJ, NNB2, NX, PMX, PX, PXU, PX2, QA, QA2, QG, QG2, QH, QHP1, QHQ4, QH26, QH4, QSW4, QTP, QTP2, QX, QXB2, QXC, QXC9, QXE, QXE2, QXE4, QXE6, QXE8, QXF, QXF2, QXH4, QXQ, QXS2, QXU, QX2, QX26, QX4, QX7, RG, RH, RHA2, RHQ4, RH2, RH26, RMG2, RX, RXU, RX2, RX4, SH, SHQ4, SMC4, SM12, SM14, SM22, SM24, SWG4, SX, SXE4, SXU, SX4, SX7, TX, TXE, TXU, TXU1, TX2, TX4, UX, VAA, VAA1, VA2, VEN1, VEN4, VES1, VGG2, VMT, VNG4, VSD, VSD1, VSD2, VSD7, VS17, VX, VXU, VXU1, VX2, VX4
			1	-	-	1122111	LHB2, QAB2, VEE1
			1	-	-	1267449	SM11, SM21, VMG1
			-	1	-		
	30700-ZE8-003	CAP ASSY., NOISE SUPPRESSOR	1	-	-	-----	LVL, QVL
			1	-	-	1383993	BL
3	31510-ZE1-811	COIL ASSY., LAMP (12V/25W)	1	-	-	-----	NAX, NTB, RHA2, SMC4
			2	-	-	-----	VES, VES1
	31630-ZL0-V31	COIL ASSY., CHARGE	1	-	-	-----	VEN, VEN4
4	31511-ZE1-000	CLAMPER, CORD	1	-	-	-----	NAX, NAX1, NJC1, NMB, NTB, NTU, NWA, QG2, QH4, QSW4, QTP, QTP2, QXE, QXE2, QXE4, QXE6, QXE8, QXH4, QXS2, RHA2, RMG2, SMC4, SMG1, SMG2, SXE4, TXE, TXU1, VEN, VEN4, VES, VES1
5	31512-ZE1-000	GROMMET, CORD	1	-	-	-----	NAX, NAX1, NJC1, NMB, NTB, NTU, NWA, QG2, QH4, QSW4, QTP, QTP2, QXE, QXE2, QXE4, QXE6, QXE8, QXH4, QXS2, RHA2, RMG2, SMC4, SMG1, SMG2, SWG4, SXE4, TXE, TXU1, VEN, VEN4, VES, VES1
6	31630-ZE1-003	COIL ASSY., CHARGE (1A)	1	-	-	-----	QXE, QXE2, QXE4, QXE6, QXE8, SMG1, SMG2, SXE4, TXE, TXU1
7	90015-883-000	BOLT, FLANGE, 6X28	2	-	-	-----	QXE8
			4	-	-	-----	NAX1, NJC1, NMB, NTU, NWA, QG2, QH4, QSW4, QTP, QTP2, QXH4, QXS2, RMG2, VES, VES1
			2	-	-	-----	NAX, NTB, QXE, QXE2, QXE4, QXE6, QXE8, RHA2, SMC4, SMG1, SMG2, SXE4, TXE, TXU1

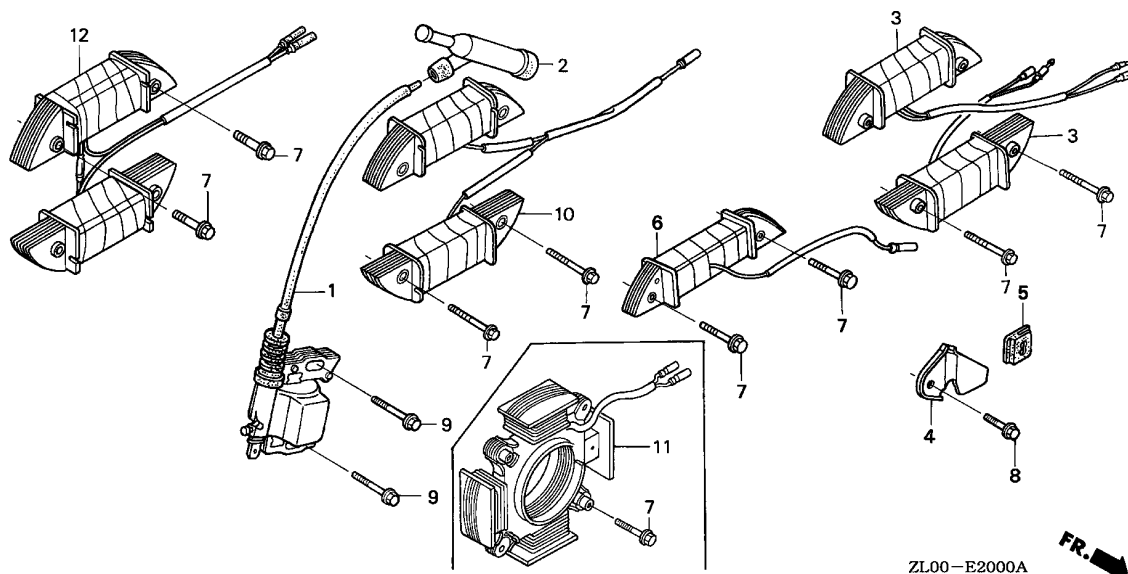

Ref. No.	Part No.	Description	Reqd. QTY			Serial No.	Parts catalogue code
			(1)	GX200 (2)	(3)		
8	90019-883-000	BOLT, FLANGE, 5X10	1	-	-	-----	NAX,NAX1,NJC1,NMB,NTB,NTU,NWA,QG2,QH4,QSW4,QTP,QTP2,QXE,QXE2,QXE4,QXE6,QXE8,QXH4,QXS2,RHA2,RMG2,SMC4,SMG1,SMG2,SXE4,TXE,TXU1,VEN,VEN4,VES,VES1
9	90121-952-000	BOLT, FLANGE, 6X25	2	2	2	-----	NWA,QTP,QXS2,RMG2
10	31510-ZE1-711	COIL ASSY., LAMP (12V/50W) ..	1	-	-	-----	NWA,QTP,QXS2,RMG2
11	31630-ZH8-W01	COIL ASSY., CHARGE (12V-7A) -	1	-	-	-----	NTU,QG2,QH4,QSW4,QTP2,QXH4
12	31630-ZF1-801	COIL ASSY., CHARGE (2.8A) ...	1	-	-	-----	NAX1,NJC1,NMB



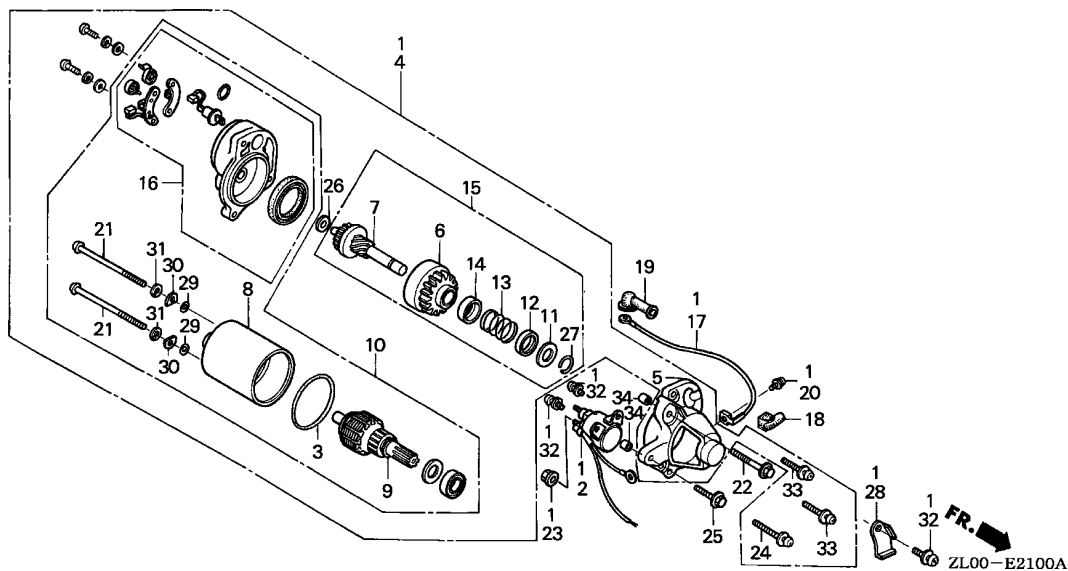

Ref. No.	L.O.N.	(Relative ref. Number) Description	F.R.T.
1	6121D5	MOTOR, STARTER	0.2
2	6121C9	SWITCH, STARTER MAGNETIC	0.2
5	6121B1	COVER, GEAR	0.3
7		(6,11,12,13,14)	
	6121C6	SHAFT UNIT, GEAR	0.4
8	6121D1	YOKE, STARTER	0.4
9	6121C5	ROTOR, STARTER	0.4
10	6121B8	MOTOR ONLY	0.3
15		(6)	
	6121B0	CLUTCH, OVERRUNNING	0.4
16	6121D2	BRACKET, STARTER :FRONT	0.4

Ref. No.	Part No.	Description	Reqd. QTY			Serial No.	Parts catalogue code
			(1)	(2)	(3)		
1	31200-ZL0-811	MOTOR ASSY., STARTER	1	-	-	-----	NAX1,NJC1,NMB,NTU,QH4,QTP2,QXE6,QXH4,SMG1,SMG2,SWG4
2	31204-ZE1-003	SWITCH COMP., STARTING MAGNET	1	-	-	-----	NAX1,NJC1,NMB,NTU,QH4,QSW4,QTP2,QXE,QXE2,QXE4,QXE6,QXE8,QXH4,SMG1
3	31206-KN7-670	O-RING	1	-	-	-----	SMG2,SWG4,SXE4,TXE,TXU1
4	31210-ZE1-723	MOTOR UNIT, STARTER (SM-11205) (181MM)	1	-	-	-----	NAX1,NJC1,NMB,NTU,QH4,QSW4,QTP2,QXE,QXE2,QXE4,QXE6,QXE8,QXH4,SMG1
5	31212-ZE1-003	COVER COMP., GEAR	1	-	-	-----	SMG2,SWG4,SXE4,TXE,TXU1
6	31214-ZE1-003	PINION ASSY.	1	-	-	-----	NAX1,NJC1,NMB,NTU,QH4,QSW4,QTP2,QXE,QXE2,QXE4,QXE6,QXE8,QXH4,SMG1
7	31215-ZE1-003	SHAFT UNIT, GEAR	1	-	-	-----	SMG2,SWG4,SXE4,TXE,TXU1
8	31216-ZE1-731	YOKE ASSY.	1	-	-	-----	NAX1,NJC1,NMB,NTU,QH4,QSW4,QTP2,QXE,QXE2,QXE4,QXE6,QXE8,QXH4,SMG1
9	31217-ZE1-722	ROTOR ASSY.	1	-	-	-----	SMG2,SWG4,SXE4,TXE,TXU1
10	31220-ZE1-722	MOTOR ONLY	1	-	-	-----	NAX1,NJC1,NMB,NTU,QH4,QSW4,QTP2,QXE,QXE2,QXE4,QXE6,QXE8,QXH4,SMG1
11	31221-ZE1-003	PIECE A, STOPPER	1	-	-	-----	SMG2,SWG4,SXE4,TXE,TXU1
12	31222-ZE1-003	PIECE B, STOPPER	1	-	-	-----	NAX1,NJC1,NMB,NTU,QH4,QSW4,QTP2,QXE,QXE2,QXE4,QXE6,QXE8,QXH4,SMG1
13	31223-ZE1-003	SPRING, RETURN	1	-	-	-----	SMG2,SWG4,SXE4,TXE,TXU1

Ref. No.	Part No.	Description	Reqd. QTY			Serial No.	Parts catalogue code
			(1)	GX200 (2)	(3)		
14	31224-ZE1-003	COVER, SPRING	1	-	-	-----	NAX1,NJC1,NMB,NTU,QH4,QSW4,QTP2,QXE,QXE2,QXE4,QXE6,QXE8,QXH4,SMG1 SMG2,SWG4,SXE4,TXE,TXU1
15	31230-ZE1-003	GEAR ASSY.	1	-	-	-----	NAX1,NJC1,NMB,NTU,QH4,QSW4,QTP2,QXE,QXE2,QXE4,QXE6,QXE8,QXH4,SMG1 SMG2,SWG4,SXE4,TXE,TXU1
16	31235-ZE1-013	BRACKET COMP., FR.	1	-	-	-----	NAX1,NJC1,NMB,NTU,QH4,QSW4,QTP2,QXE,QXE2,QXE4,QXE6,QXE8,QXH4,SMG1 SMG2,SWG4,SXE4,TXE,TXU1
17	32410-ZE1-000	CORD, MAGNET SWITCH	1	-	-	-----	NAX1,NJC1,NMB,NTU,QH4,QSW4,QTP2,QXE,QXE2,QXE4,QXE6,QXE8,QXH4,SMG1 SMG2,SWG4,SXE4,TXE,TXU1
18	32411-ZE1-000	COVER, MAGNETIC SWITCH	1	-	-	-----	NAX1,NJC1,NMB,NTU,QH4,QSW4,QTP2,QXE,QXE2,QXE4,QXE6,QXE8,QXH4,SMG1 SMG2,SWG4,SXE4,TXE,TXU1
19	32411-253-000	COVER, STARTER MOTOR TERMINAL	1	-	-	-----	NAX1,NJC1,NMB,NTU,QH4,QSW4,QTP2,QXE,QXE2,QXE4,QXE6,QXE8,QXH4,SMG1 SMG2,SWG4,SXE4,TXE,TXU1
20	90010-ZE1-003	SCREW-WASHER, 5X8	1	-	-	-----	NAX1,NJC1,NMB,NTU,QH4,QSW4,QTP2,QXE,QXE2,QXE4,QXE6,QXE8,QXH4,SMG1 SMG2,SWG4,SXE4,TXE,TXU1
21	90012-ZE1-721	BOLT, SETTING	2	-	-	-----	NAX1,NJC1,NMB,NTU,QH4,QSW4,QTP2,QXE,QXE2,QXE4,QXE6,QXE8,QXH4,SMG1 SMG2,SWG4,SXE4,TXE,TXU1
22	90017-883-000	BOLT, FLANGE, 6X32	1	-	-	-----	NAX1,NJC1,NMB,NTU,QH4,QSW4,QTP2,QXE,QXE2,QXE4,QXE6,QXE8,QXH4,SMG1 SMG2,SWG4,SXE4,TXE,TXU1
23	90071-MB0-000	NUT-WASHER, 6MM	2	-	-	-----	NAX1,NJC1,NMB,NTU,QH4,QSW4,QTP2,QXE,QXE2,QXE4,QXE6,QXE8,QXH4,SMG1 SMG2,SWG4,SXE4,TXE,TXU1
24	90115-GB4-700	SCREW-WASHER, 5X30	1	-	-	-----	NAX1,NJC1,NMB,NTU,QH4,QSW4,QTP2,QXE,QXE2,QXE4,QXE6,QXE8,QXH4,SMG1 SMG2,SWG4,SXE4,TXE,TXU1
25	90121-952-000	BOLT, FLANGE, 6X25	1	-	-	-----	NAX1,NJC1,NMB,NTU,QH4,QSW4,QTP2,QXE,QXE2,QXE4,QXE6,QXE8,QXH4,SMG1 SMG2,SWG4,SXE4,TXE,TXU1
26	90502-187-701	WASHER, PINION	1	-	-	-----	NAX1,NJC1,NMB,NTU,QH4,QSW4,QTP2,QXE,QXE2,QXE4,QXE6,QXE8,QXH4,SMG1 SMG2,SWG4,SXE4,TXE,TXU1
27	90603-ZE1-003	CIRCLIP, 10.2MM	1	-	-	-----	NAX1,NJC1,NMB,NTU,QH4,QSW4,QTP2,QXE,QXE2,QXE4,QXE6,QXE8,QXH4,SMG1 SMG2,SWG4,SXE4,TXE,TXU1
28	90631-ZE1-003	HOLDER, HARNESS	1	-	-	-----	NAX1,NJC1,NMB,NTU,QH4,QSW4,QTP2,QXE,QXE2,QXE4,QXE6,QXE8,QXH4,SMG1 SMG2,SWG4,SXE4,TXE,TXU1
29	91301-ZE1-003	O-RING	2	-	-	-----	NAX1,NJC1,NMB,NTU,QH4,QSW4,QTP2,QXE,QXE2,QXE4,QXE6,QXE8,QXH4,SMG1 SMG2,SWG4,SXE4,TXE,TXU1
30	91402-ZE6-003	WASHER, SPECIAL	2	-	-	-----	NAX1,NJC1,NMB,NTU,QH4,QSW4,QTP2,QXE,QXE2,QXE4,QXE6,QXE8,QXH4,SMG1 SMG2,SWG4,SXE4,TXE,TXU1
31	91403-ZE6-003	WASHER, SPRING	2	-	-	-----	NAX1,NJC1,NMB,NTU,QH4,QSW4,QTP2,QXE,QXE2,QXE4,QXE6,QXE8,QXH4,SMG1 SMG2,SWG4,SXE4,TXE,TXU1
32	93892-05014-08	SCREW-WASHER, 5X14	3	-	-	-----	NAX1,NJC1,NMB,NTU,QH4,QSW4,QTP2,QXE,QXE2,QXE4,QXE6,QXE8,QXH4,SMG1 SMG2,SWG4,SXE4,TXE,TXU1
33	93892-05020-08	SCREW-WASHER, 5X20	2	-	-	-----	NAX1,NJC1,NMB,NTU,QH4,QSW4,QTP2,QXE,QXE2,QXE4,QXE6,QXE8,QXH4,SMG1 SMG2,SWG4,SXE4,TXE,TXU1
34	94301-08100	DOWEL PIN, 8X10	2	-	-	-----	NAX1,NJC1,NMB,NTU,QH4,QSW4,QTP2,QXE,QXE2,QXE4,QXE6,QXE8,QXH4,SMG1 SMG2,SWG4,SXE4,TXE,TXU1

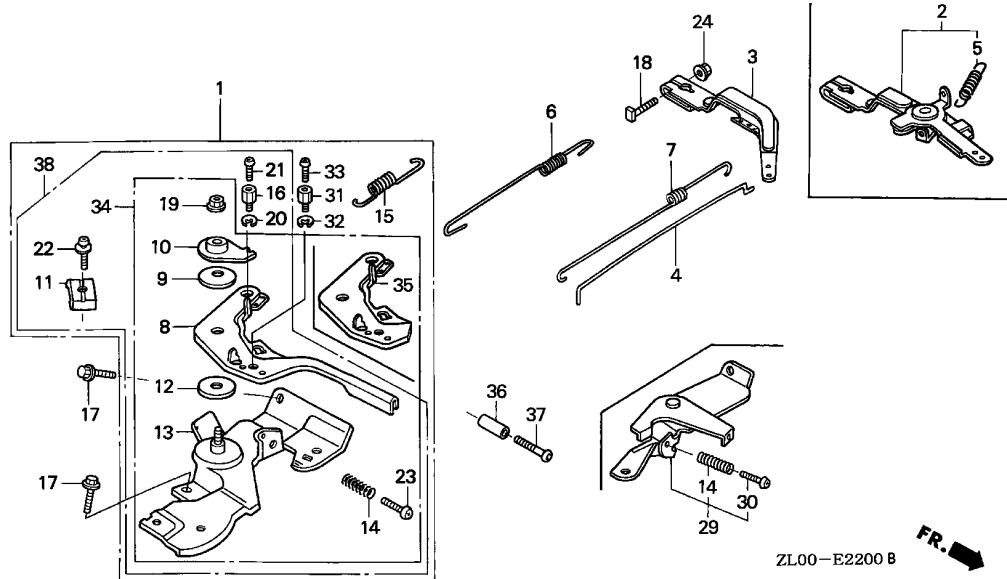

Ref. No.	L.O.N.	(Relative ref. Number) Description	F.R.T.
1		(29,38)	
1	1161A5	CONTROL, THROTTLE/GOVERNOR ...	0.2
3		(2)	
	1161A0	ARM, GOVERNOR	0.3
4	1161B1	ROD, GOVERNOR	0.3
6	1161C5	SPRING, GOVERNOR	0.2
7	1161C2	SPRING, THROTTLE RETURN	0.3
13	1161A2	BASE, CONTROL	0.3
15	1161B7	SPRING, CABLE RETURN	0.2



Ref. No.	Part No.	Description	Reqd. QTY			Serial No.	Parts catalogue code
			GX200	(1)	(2)		
1	16500-ZH8-811	CONTROL ASSY. (REMOTE INTL) ..	1	-	-	1113369 VEE1	
	16500-ZH8-812	1	-	-	1180377 LJ,LJG,LSJ,NAX,NAX1,NJ,NJG,NMB,NTB,NW,NWA,QSW4,SJ,SJG	
	16500-ZH8-813	1	-	-	1180378 1288955 NDF1,NDJ,SM11,SM12,SM14	
			1	-	-	1288955 LJ,LJG,LSJ,NAX,NAX1,NJ,NJG,NMB,NTB,NW,NWA,QSW4,SJ,SJG	
			1	-	-	1288956 LJC1,NTU,NWB2,QJF	
			1	-	-	1288956 LJ,LJG,LSJ,NAX,NAX1,NDF1,NDJ,NJ,NJG,NMB,NTB,NW,NWA,QSW4,SJ,SJG	
			1	-	-	1288956 1310619 SM11,SM12,SM14	
	16500-ZH8-821	CONTROL ASSY. (REMOTE)	1	-	-	HXQ,LDN,LD4,QA,QXE,QXF,QXQ	
			1	-	-	1180377 HX,HX2,HX26,HX4,LD,LDB1,LDB2,LH,LHB2,LHP1,LHQ4,LX,LX2,LX4,NX,QAB2	
						QA2,QD,QH,QHP1,QHQ4,QH26,QM,QT,QTP,QX,QXE2,QXE4,QXE6,QXF2,QXS2	
						QX2,QX26,QX4,RH,RHA2,RHQ4,RH2,RH26,RMG2,RX,RX4,SD,SDB1,SDB2,SDN	
						SD4,SH,SHQ4,SMC4,SX,SXE4,SX4	
	16500-ZH8-822	1	-	-	1288719 HXU,QXU,RXU,SXU	
			1	-	-	1180378 1288719 HX,HX26,HX4,LD,LDB1,LDB2,LH,LHB2,LHP1,LHQ4,LX,LX4,NX,QAB2,QD,QH	
						QHP1,QHQ4,QH26,QM,QT,QTP,QX,QXE4,QXE6,QX26,QX4,RH,RHQ4,RH26,RX	
						RX4,SD,SDB1,SDB2,SDN,SD4,SH,SHQ4,SMC4,SX,SXE4,SX4	
	16500-ZH8-823	1	-	-	1180378 1288955 HX2,LX2,QA2,QXE2,QXF2,QXS2,QX2,RHA2,RH2,RMG2	
			1	-	-	1288720 BL,LVL,QG,QG2,QVL,QXB2,QX7,RG,RX2,SX7	
			1	-	-	1288720 HX,HXU,HX26,HX4,LD,LDB1,LDB2,LH,LHB2,LHP1,LHQ4,LX,LX4,NX,QAB2,QD	
						QH,QHP1,QHQ4,QH26,QM,QT,QTP,QX,QXE4,QXE6,QXU,QX26,QX4,RH,RHQ4	
						RH26,RX,RXU,RX4,SD,SDB1,SDB2,SDN,SD4,SH,SHQ4,SMC4,SX,SXE4,SXU,SX4	
			1	-	-	1288956 HX2,LX2,QA2,QXE2,QXF2,QXS2,QX2,RHA2,RH2,RMG2	
	16500-ZH8-851	CONTROL ASSY. (CYCLONE)	1	-	-	1180377 QXC,QXC9	
	16500-ZH8-852	1	-	-	1180378 1288955 QXC,QXC9	
	16500-ZH8-853	1	-	-	1288956 QXC,QXC9	
	16500-ZH8-863	CONTROL ASSY. (REMOTE)	1	-	-	NJC1	
	16500-ZH8-871	CONTROL ASSY. (CYCLONE-REMOTE)	1	-	-	1180377 QTP2	
	16500-ZH8-872	1	-	-	1180378 1288955 QTP2	

Ref. No.	Part No.	Description	Reqd. QTY			Serial No.	Parts catalogue code
			(1)	GX200 (2)	(3)		
(1)	16500-ZH8-873	CONTROL ASSY. (CYCLONE-REMOTE)	1	-	-	1288956	----- QTP2
	16500-ZH8-P40	1	-	-	-----	QH4,QXH4
	16500-ZH8-S42	CONTROL ASSY. (TB560)	1	-	-	1288821	SMG1
	16500-ZH8-S43	1	-	-	-----	SMG2
	16500-ZH8-U42	CONTROL ASSY. (NORTON)	1	-	-	1288822	SMG1
	16500-ZH8-U43	1	-	-	1288719	SM21
			1	-	-	-----	SM22,SM24
			1	-	-	1288720	SM21
			1	-	-	1310620	SM11,SM12,SM14
	16500-ZLO-V90	CONTROL ASSY. (REMOTE INTL LOCK)	1	-	-	1113370	1180377 VEE1
	16500-ZLO-V91	1	-	-	1180378	1269858 VEE1
2	16550-ZLO-V30	ARM COMP., GOVERNOR	1	-	-	-----	VEN,VEN4,VES
3	16551-ZLO-000	ARM, GOVERNOR	1	-	-	-----	BL,HX,HXQ,HXU,HX2,HX26,HX4,LD,LDB1,LDB2,LDN,LD4,LH,LHB2,LHP1,LHQ4 LJ,LJC1,LJG,LSJ,LVL,LX,LX2,LX4,NAX,NAX1,NDF1,NDJ,NJ,NJC1,NJG,NMB NTB,NTU,NW,NWA,NWB2,NX,PMX,PX,PXU,PX2,QA,QAB2,QA2,QD,QG,QG2,QH QHP1,QHQ4,QH26,QH4,QJF,QJF1,QM,QSW4,QT,QTP,QTP2,QVL,QX,QXB2,QXC QXC9,QXE,QXE2,QXE4,QXE6,QXE8,QXF,QXF2,QXH4,QXQ,QXS2,QXU,QX2,QX26 QX4,QX7,RG,RH,RHA2,RHQ4,RH2,RH26,RMG2,RX,RXU,RX2,RX4,SD,SDB1,SDB2 SDN,SD4,SH,SHQ4,SJ,SJG,SMC4,SMG1,SMG2,SM11,SM12,SM14,SM21,SM22 SM24,SWG4,SX,SXE4,SXU,SX4,SX7,TX,TXE,TXU,TXU1,TX2,TX4,UX,VAA,VAA1 VA2,VEE1,VEN1,VES1,VGG2,VMG1,VMT,VNG4,VSD,VSD1,VSD2,VSD7,VS17,VX VXU,VXU1,VX2,VX4
4	16555-ZE1-000	ROD, GOVERNOR	1	-	1	-----	BL,HX,HXQ,HXU,HX2,HX26,HX4,LD,LDB1,LDB2,LDN,LD4,LH,LHB2,LHP1,LHQ4 LJ,LJC1,LJG,LSJ,LVL,LX,LX2,LX4,NAX,NAX1,NDF1,NDJ,NJ,NJC1,NJG,NMB NTB,NTU,NW,NWA,NWB2,NX,PMX,PX,PXU,PX2,QA,QAB2,QA2,QD,QG,QG2,QH QHP1,QHQ4,QH26,QH4,QJF,QJF1,QM,QSW4,QT,QTP,QTP2,QVL,QX,QXB2,QXC QXC9,QXE,QXE2,QXE4,QXE6,QXE8,QXF,QXF2,QXH4,QXQ,QXS2,QXU,QX2,QX26 QX4,QX7,RG,RH,RHA2,RHQ4,RH2,RH26,RMG2,RX,RXU,RX2,RX4,SD,SDB1,SDB2 SDN,SD4,SH,SHQ4,SJ,SJG,SMC4,SMG1,SMG2,SM11,SM12,SM14,SM21,SM22 SM24,SWG4,SX,SXE4,SXU,SX4,SX7,TX,TXE,TXU,TXU1,TX2,TX4,UX,VAA,VAA1 VA2,VEE1,VEN1,VES1,VGG2,VMG1,VMT,VNG4,VSD,VSD1,VSD2,VSD7,VS17,VX VXU,VXU1,VX2,VX4
	16555-ZLO-V30	-	1	1	-----	VEN,VEN4,VES
5	16559-ZLO-V30	SPRING, GOVERNOR ARM RETURN	1	-	-	-----	VEN,VEN4,VES
6	16561-ZLO-000	SPRING, GOVERNOR	1	-	-	-----	BL,HX,HXQ,HXU,HX2,HX26,HX4,LD,LDB1,LDB2,LDN,LD4,LH,LHB2,LHP1,LHQ4 LJ,LJC1,LJG,LSJ,LVL,LX,LX2,LX4,NAX,NAX1,NDF1,NDJ,NJ,NJC1,NJG,NMB NTB,NTU,NW,NWA,NWB2,NX,PMX,PX,PXU,PX2,QA,QAB2,QA2,QD,QG,QG2,QH QHP1,QHQ4,QH26,QH4,QJF,QJF1,QM,QSW4,QT,QTP,QTP2,QVL,QX,QXB2,QXC QXC9,QXE,QXE2,QXE4,QXE6,QXE8,QXF,QXF2,QXH4,QXQ,QXS2,QXU,QX2,QX26 QX4,QX7,RG,RH,RHA2,RHQ4,RH2,RH26,RMG2,RX,RXU,RX2,RX4,SD,SDB1,SDB2 SDN,SD4,SH,SHQ4,SJ,SJG,SMC4,SMG1,SMG2,SM11,SM12,SM14,SM21,SM22 SM24,SWG4,SX,SXE4,SXU,SX4,SX7,TX,TXE,TXU,TXU1,TX2,TX4,UX,VAA,VAA1 VA2,VEE1,VEN1,VES1,VGG2,VMG1,VSD2,VX,VX2,VX4
	16561-ZLO-U30	-	1	1	-----	VNG4,VSD,VSD7,VXU,VXU1
	16561-ZLO-V30	1	-	-	-----	VAA,VAA1,VEN,VEN4,VMT,VSD1,VS17
			1	-	-	1289083	VES
	16561-ZLO-W50	1	-	-	1289084	VES



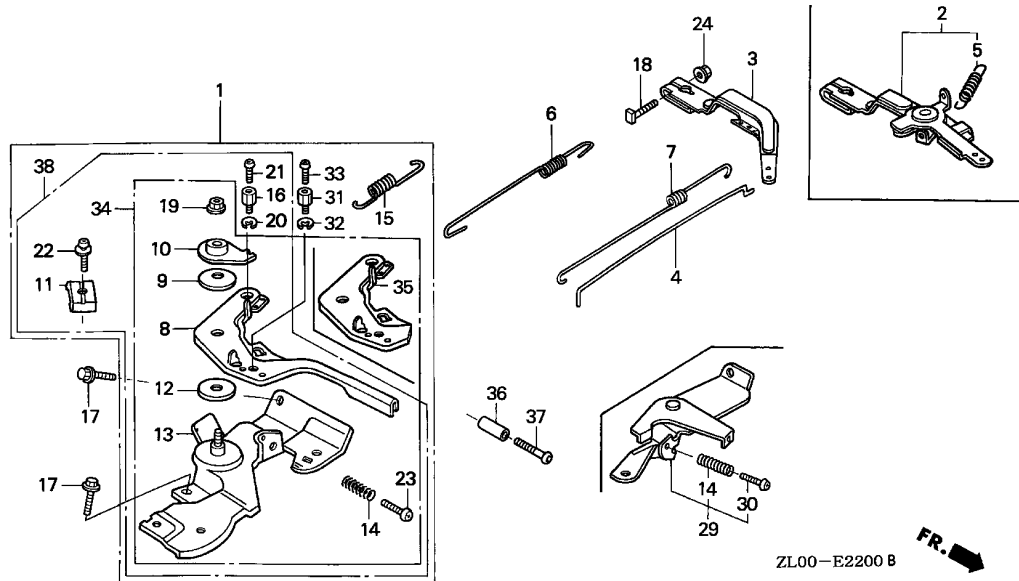

Ref. No.	Part No.	Description	Reqd. QTY			Serial No.	Parts catalogue code
			(1)	(2)	(3)		
7	16562-ZE1-020	SPRING, THROTTLE RETURN	1	-	-	-	BL, HX, HXQ, HXU, HX2, HX26, HX4, LD, LDB1, LDB2, LDN, LD4, LH, LHB2, LHP1, LHQ4, LJ, LJC1, LJG, LSJ, LVL, LX, LX2, LX4, NAX, NAX1, NDF1, NDJ, NJ, NJC1, NJG, NMB, NTB, NTU, NW, NWA, NWB2, NX, PMX, PX, PXU, PX2, QA, QAB2, QA2, QD, QG, QG2, QH, QHP1, QHQ4, QH26, QH4, QJF, QJF1, QM, QSW4, QT, QTP, QTP2, QVL, QX, QXB2, QXC, QXC9, QXE, QXE2, QXE4, QXE6, QXE8, QXF, QXF2, QXH4, QXQ, QXS2, QXU, QX2, QX26, QX4, QX7, RG, RH, RHA2, RHQ4, RH2, RH26, RMG2, RX, RXU, RX2, RX4, SD, SDB1, SDB2, SDN, SD4, SH, SHQ4, SJ, SJG, SMC4, SMG1, SMG2, SM11, SM12, SM14, SM21, SM22, SM24, SWG4, SX, SXE4, SXU, SX4, SX7, TX, TXE, TXU, TXU1, TX2, TX4, UX, VAA, VAA1, VA2, VEE1, VEN1, VES1, VGG2, VMG1, VMT, VNG4, VSD, VSD1, VSD2, VSD7, VS17, VX, VXU, VXU1, VX2, VX4
	16562-ZL0-V30	-	1	1	-	VEN, VEN4, VES
8	16571-ZH8-000	LEVER, CONTROL	1	-	-	-	HXQ, LDN, LD4, QA, QXE, QXF, QXQ, TX4, UX
	16571-ZH8-010	1	-	-	1180377	HX, HX2, HX26, HX4, LD, LDB1, LDB2, LH, LHB2, LHP1, LHQ4, LJ, LJG, LSJ, LX, LX2, LX4, NAX, NAX1, NJ, NJG, NMB, NTB, NW, NWA, NX, PMX, PX, PX2, QAB2, QA2, QD, QH, QHP1, QHQ4, QH26, QM, QSW4, QT, QTP, QTP2, QX, QXC, QXC9, QXE2, QXE4, QXE6, QXF2, QXS2, QX2, QX26, QX4, RH, RHA2, RHQ4, RH2, RH26, RMG2, RX, RX4, SD, SDB1, SDB2, SDN, SD4, SH, SHQ4, SJ, SJG, SMC4, SX, SXE4, SX4, TX, TXE, TX2, VA2, VEE1, VGG2, VX, VX2, VX4
			1	-	-	-	NDJ, SM11
			1	-	-	1288719	HXU, NDF1, PXU, QXU, RXU, SXU, TXU, TXU1
			1	-	-	1288955	SMG1, SM21
			1	-	-	1180378	VEE1
			1	-	-	1180378	1288719 HX, HX26, HX4, LD, LDB1, LDB2, LH, LHB2, LHP1, LHQ4, LX, LX4, NW, NWA, NX, PMX, PX, QAB2, QD, QH, QHP1, QHQ4, QH26, QM, QSW4, QT, QTP, QX, QXC, QXE4, QXE6, QX26, QX4, RH, RHQ4, RH26, RX, RX4, SD, SDB1, SDB2, SDN, SD4, SH, SHQ4, SMC4, SX, SXE4, SX4, TX, TXE, VX, VX4
			1	-	-	1180378	1288955 HX2, LJ, LJG, LSJ, LX2, NAX, NAX1, NJ, NJG, NMB, NTB, PX2, QA2, QTP2, QXC9, QXE2, QXF2, QXS2, QX2, RHA2, RH2, RMG2, SJ, SJG, TX2, VA2, VGG2, VX2

Ref. No.	Part No.	Description	Reqd. QTY			Serial No.	Parts catalogue code	
			(1)	GX200 (2)	(3)			
(8)	16571-ZH8-020	LEVER, CONTROL	1	-	-	-----	BL, LJC1, LVL, NDJ, NTU, NWB2, QG, QG2, QH4, QJF, QVL, QXB2, QXE8, QXH4, QX7, RG, RX2, SMG2, SM11, SM12, SM14, SM22, SM24, SWG4, SX7, VEN1, VES1	
			1	-	-	1288720	-----	HX, HXU, HX26, HX4, LD, LDB1, LDB2, LH, LHB2, LHP1, LHQ4, LX, LX4, NDF1, NW, NWA, NX, PMX, PX, PXU, QAB2, QD, QH, QHP1, QHQ4, QH26, QM, QSW4, QT, QTP, QX, QXC, QXE4, QXE6, QXU, QX26, QX4, RH, RHQ4, RH26, RX, RXU, RX4, SD, SDB1, SDB2, SDN, SD4, SH, SHQ4, SMC4, SX, SXE4, SXU, SX4, TX, TXE, TXU, TXU1, VX, VX4
			1	-	-	1288956	-----	HX2, LJ, LJG, LSJ, LX2, NAX, NAX1, NJ, NJG, NMB, NTB, PX2, QA2, QTP2, QXC9, QXE2, QXF2, QXS2, QX2, RHA2, RH2, RMG2, SJ, SJG, SMG1, SM21, TX2, VA2, VGG2, VX2
9	16574-ZE1-000	SPRING, LEVER	-	1	1			
			1	-	-	-----	-----	BL, HX, HXQ, HXU, HX2, HX26, HX4, LD, LDB1, LDB2, LDN, LD4, LH, LHB2, LHP1, LHQ4, LJ, LJC1, LJG, LSJ, LVL, LX, LX2, LX4, NAX, NAX1, NDF1, NDJ, NJ, NJC1, NJG, NMB, NTB, NTU, NW, NWA, NWB2, NX, PMX, PX, PXU, PX2, QA, QAB2, QA2, QD, QG, QG2, QH, QHP1, QHQ4, QH26, QH4, QJF, QM, QSW4, QT, QTP, QTP2, QVL, QX, QXB2, QXC, QXC9, QXE, QXE2, QXE4, QXE6, QXE8, QXF, QXF2, QXH4, QXQ, QXS2, QXU, QX2, QX26, QX4, QX7, RG, RH, RHA2, RHQ4, RH2, RH26, RMG2, RX, RXU, RX2, RX4, SD, SDB1, SDB2, SDN, SD4, SH, SHQ4, SJ, SJG, SMC4, SMG1, SMG2, SM11, SM12, SM14, SM21, SM22, SM24, SWG4, SX, SXE4, SXU, SX4, SX7, TX, TXE, TXU, TXU1, TX2, TX4, UX, VA2, VEN1, VES1, VGG2, VX, VX2, VX4
10	16575-ZH8-000	WASHER, CONTROL LEVER	1	-	-	-----	1269858 VEE1	
			-	1	1			
			1	-	-	-----	-----	
11	16576-891-000	HOLDER, CABLE	1	-	-	-----	-----	
			1	-	-	1269858	-----	BL, HX, HXQ, HXU, HX2, HX26, HX4, LD, LDB1, LDB2, LDN, LD4, LH, LHB2, LHP1, LHQ4, LJ, LJC1, LJG, LSJ, LVL, LX, LX2, LX4, NAX, NAX1, NDF1, NDJ, NJ, NJC1, NJG, NMB, NTB, NTU, NW, NWA, NWB2, NX, QA, QAB2, QA2, QD, QG, QG2, QH, QHP1, QHQ4, QH26, QH4, QJF, QM, QSW4, QT, QTP, QTP2, QVL, QX, QXB2, QXC, QXC9, QXE, QXE2, QXE4, QXE6, QXF, QXF2, QXH4, QXQ, QXS2, QXU, QX2, QX26, QX4, QX7, RG, RH, RHA2, RHQ4, RH2, RH26, RMG2, RX, RXU, RX2, RX4, SD, SDB1, SDB2, SDN, SD4, SH, SHQ4, SJ, SJG, SMC4, SMG1, SMG2, SM11, SM12, SM14, SM21, SM22, SM24, SWG4, SX, SXE4, SXU, SX4, SX7
			1	-	-	-----	1269858 VEE1	
			-	1	1			
12	16578-ZE1-000	SPACER, CONTROL LEVER	1	-	-	-----	-----	
			1	-	-	1269858	-----	BL, HX, HXQ, HXU, HX2, HX26, HX4, LD, LDB1, LDB2, LDN, LD4, LH, LHB2, LHP1, LHQ4, LJ, LJC1, LJG, LSJ, LVL, LX, LX2, LX4, NAX, NAX1, NDF1, NDJ, NJ, NJC1, NJG, NMB, NTB, NTU, NW, NWA, NWB2, NX, PMX, PX, PXU, PX2, QA, QAB2, QA2, QD, QG, QG2, QH, QHP1, QHQ4, QH26, QH4, QJF, QM, QSW4, QT, QTP, QTP2, QVL, QX, QXB2, QXC, QXC9, QXE, QXE2, QXE4, QXE6, QXE8, QXF, QXF2, QXH4, QXQ, QXS2, QXU, QX2, QX26, QX4, QX7, RG, RH, RHA2, RHQ4, RH2, RH26, RMG2, RX, RXU, RX2, RX4, SD, SDB1, SDB2, SDN, SD4, SH, SHQ4, SJ, SJG, SMC4, SMG1, SMG2, SM11, SM12, SM14, SM21, SM22, SM24, SWG4, SX, SXE4, SXU, SX4, SX7, TX, TXE, TXU, TXU1, TX2, TX4, UX, VA2, VEN1, VES1, VGG2, VX, VX2, VX4
			1	-	-	-----	1269858 VEE1	
			-	1	1			



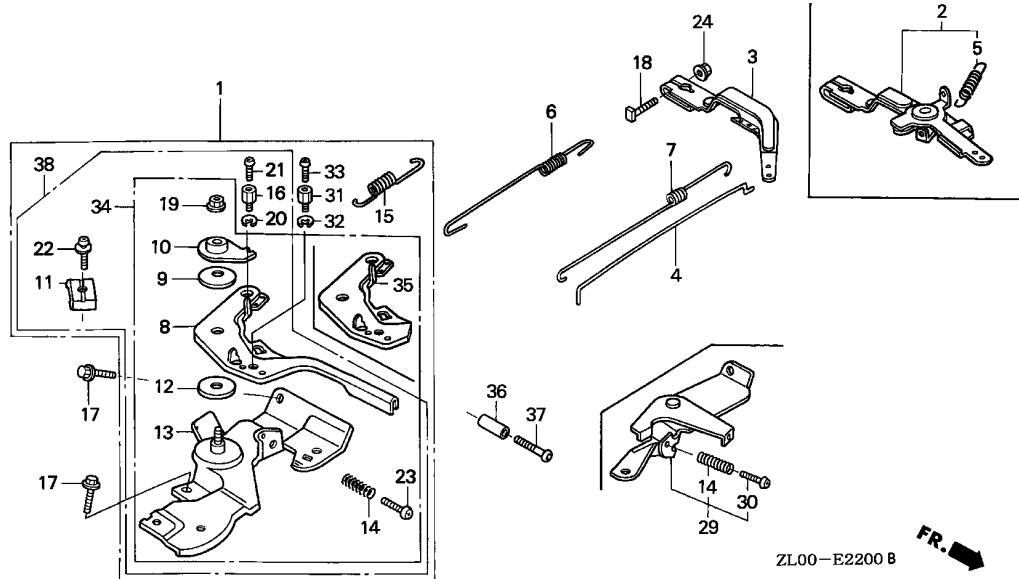

Ref. No.	Part No.	Description	Reqd. QTY			Serial No.	Parts catalogue code
			(1)	(2)	(3)		
13	16580-ZH8-811	BASE COMP., CONTROL (REMOTE)	1	-	-	-----	HXQ,LDN,LD4,QA,QXE,QXF,QXQ
			1	-	-	1180377	HX,HX2,HX26,HX4,LD,LDB1,LDB2,LH,LHB2,LHP1,LHQ4,LJ,LJG,LSJ,LX,LX2,LX4,NAX,NAX1,NJ,NJG,NMB,NTB,NW,NWA,NX,QAB2,QA2,QD,QH,QHP1,QHQ4,QH26,QM,QSW4,QT,QTP,QX,QXE2,QXE4,QXE6,QXF2,QXS2,QX2,QX26,QX4,RH,RHA2,RHQ4,RH2,RH26,RMG2,RX,RX4,SD,SDB1,SDB2,SDN,SD4,SH,SHQ4,SJ,SJG,SMC4,SX,SXE4,SX4,VEE1
	16580-ZH8-812	1	-	-	1288199	HXU,NDF1,QXU,RXU,SXU
			1	-	-	1288955	SMG1,SM21
			1	-	-	1180378	1269858 VEE1
			1	-	-	1180378	1288199 HX,HX26,HX4,LD,LDB1,LDB2,LH,LHB2,LHP1,LHQ4,LX,LX4,NW,NWA,NX,QAB2,QD,QH,QHP1,QHQ4,QH26,QM,QSW4,QT,QTP,QX,QXE4,QXE6,QX26,QX4,RH,RHQ4,RH26,RX,RX4,SD,SDB1,SDB2,SDN,SD4,SH,SHQ4,SMC4,SX,SXE4,SX4
			1	-	-	1180378	1288955 HX2,LJ,LJG,LSJ,LX2,NAX,NAX1,NJ,NJG,NMB,NTB,QA2,QXE2,QXF2,QXS2,QX2,RHA2,RH2,RMG2,SJ,SJG
	16580-ZH8-813	1	-	-	-----	BL,LJC1,LVL,NDJ,NJC1,NTU,NWB2,QG,QG2,QJF,QVL,QXB2,QX7,RG,RX2,SMG2,SM11,SM12,SM14,SM22,SM24,SWG4,SX7
			1	-	-	1288200	HX,HXU,HX26,HX4,LD,LDB1,LDB2,LH,LHB2,LHP1,LHQ4,LX,LX4,NDF1,NW,NWA,NX,QAB2,QD,QH,QHP1,QHQ4,QH26,QM,QSW4,QT,QTP,QX,QXE4,QXE6,QXU,QX26,QX4,RH,RHQ4,RH26,RX,RXU,RX4,SD,SDB1,SDB2,SDN,SD4,SH,SHQ4,SMC4,SX,SXE4,SXU,SX4
			1	-	-	1288956	HX2,LJ,LJG,LSJ,LX2,NAX,NAX1,NJ,NJG,NMB,NTB,QA2,QXE2,QXF2,QXS2,QX2,RHA2,RH2,RMG2,SJ,SJG,SMG1,SM21
	16580-ZH8-851	BASE COMP., CONTROL (CYCLONE)	-	-	1	-----	
	16580-ZH8-852	1	-	-	1180378	1288719 QXC
			1	-	-	1180378	1288955 QTP2,QXC9
	16580-ZH8-853	1	-	-	-----	QH4,QXH4
			1	-	-	1288720	QXC
			1	-	-	1288956	QTP2,QXC9

Ref. No.	Part No.	Description	Reqd. QTY			Serial No.	Parts catalogue code
			(1)	GX200 (2)	(3)		
13)	16580-ZH8-010	BASE COMP., CONTROL	1	-	-	-----	TX4,UX
			1	-	-	-----	1180377 PMX,PX,PX2,TX,TXE,TX2,VA2,VGG2,VX,VX2,VX4
	16580-ZH8-020	1	-	-	-----	1288719 PXU,TXU,TXU1
			1	-	-	1180378	1288719 PMX,PX,TX,TXE,VX,VX4
			1	-	-	1180378	1288955 PX2,TX2,VA2,VGG2,VX2
	16580-ZH8-030	1	-	-	-----	QXE8,VEN1,VES1
			1	-	-	1288720	----- PMX,PX,PXU,TX,TXE,TXU,TXU1,VX,VX4
			1	-	-	1288956	----- PX2,TX2,VA2,VGG2,VX2
14	16584-883-300	SPRING, CONTROL ADJUSTING ...	1	-	-	-----	BL,HX,HXQ,HXU,HX2,HX26,HX4,LD,LDB1,LDB2,LDN,LD4,LH,LHB2,LHP1,LHQ4 LJ,LJC1,LJG,LSJ,LVL,LX,LX2,LX4,NAX,NAX1,NDF1,NDJ,NJ,NJC1,NJG,NMB NTB,NTU,NW,NWA,NWB2,NX,PMX,PX,PXU,PX2,QA,QAB2,QA2,QD,QG,QG2,QH QHP1,QHQ4,QH26,QH4,QJF,QJF1,QM,QSW4,QT,QTP,QTP2,QVL,QX,QXB2,QXC QXC9,QXE,QXE2,QXE4,QXE6,QXE8,QXF,QXF2,QXH4,QXQ,QXS2,QXU,QX2,QX26 QX4,QX7,RG,RH,RHA2,RHQ4,RH2,RH26,RMG2,RX,RXU,RX2,RX4,SD,SDB1,SDB2 SDN,SD4,SH,SHQ4,SJ,SJG,SMC4,SMG1,SMG2,SM11,SM12,SM14,SM21,SM22 SM24,SWG4,SX,SXE4,SXU,SX4,SX7,TX,TXE,TXU,TXU1,TX2,TX4,UX,VA2,VEE1 VEN1,VES1,VGG2,VMG1,VNG4,VSD,VSD1,VSD2,VSD7,VS17,VX,VXU,VXU1,VX2 VX4
			-	1	1		
15	16592-ZE1-810	SPRING, CABLE RETURN	1	-	-	-----	BL,HX,HXQ,HXU,HX2,HX26,HX4,LD,LDB1,LDB2,LDN,LD4,LH,LHB2,LHP1,LHQ4 LJ,LJC1,LJG,LSJ,LVL,LX,LX2,LX4,NAX,NAX1,NDF1,NDJ,NJ,NJC1,NJG,NMB NTB,NTU,NW,NWA,NWB2,NX,QA,QAB2,QA2,QD,QG,QG2,QH,QHP1,QHQ4,QH26 QH4,QJF,QM,QSW4,QT,QTP,QTP2,QVL,QX,QXB2,QXC,QXC9,QXE,QXE2,QXE4 QXE6,QXF,QXF2,QXH4,QXQ,QXS2,QXU,QX2,QX26,QX4,QX7,RG,RH,RHA2,RHQ4 RH2,RH26,RMG2,RX,RXU,RX2,RX4,SD,SDB1,SDB2,SDN,SD4,SH,SHQ4,SJ,SJG SMC4,SMG1,SMG2,SM11,SM12,SM14,SM21,SM22,SM24,SWG4,SX,SXE4,SXU,SX4 SX7
			1	-	-	1269858	VEE1
			-	-	1		
16	16594-883-010	HOLDER, WIRE	1	-	-	-----	LJ,LJC1,LJG,LSJ,NAX,NAX1,NDF1,NDJ,NJ,NJC1,NJG,NMB,NTB,NTU,NW,NWA NWB2,QJF,QSW4,QXC,QXC9,SJ,SJG,SMG1,SMG2,SM11,SM12,SM14,SM22,SM24 SWG4
			1	-	-	1269858	VEE1
17	90013-883-000	BOLT, FLANGE, 6X12(CT200) ...	2	-	-	-----	BL,HX,HXQ,HXU,HX2,HX26,HX4,LD,LDB1,LDB2,LDN,LD4,LH,LHB2,LHP1,LHQ4 LJ,LJC1,LJG,LSJ,LVL,LX,LX2,LX4,NAX,NAX1,NDF1,NDJ,NJ,NJC1,NJG,NMB NTB,NTU,NW,NWA,NWB2,NX,PMX,PX,PXU,PX2,QA,QAB2,QA2,QD,QG,QG2,QH QHP1,QHQ4,QH26,QH4,QJF,QJF1,QM,QSW4,QT,QTP,QTP2,QVL,QX,QXB2,QXC QXC9,QXE,QXE2,QXE4,QXE6,QXE8,QXF,QXF2,QXH4,QXQ,QXS2,QXU,QX2,QX26 QX4,QX7,RG,RH,RHA2,RHQ4,RH2,RH26,RMG2,RX,RXU,RX2,RX4,SD,SDB1,SDB2 SDN,SD4,SH,SHQ4,SJ,SJG,SMC4,SMG1,SMG2,SM11,SM12,SM14,SM21,SM22 SM24,SWG4,SX,SXE4,SXU,SX4,SX7,TX,TXE,TXU,TXU1,TX2,TX4,UX,VA2,VEE1 VEN1,VES1,VGG2,VMG1,VNG4,VSD,VSD1,VSD2,VSD7,VS17,VX,VXU,VXU1,VX2 VX4
			-	2	2		
18	90015-ZE5-010	BOLT, GOVERNOR ARM	1	1	1		
19	90114-SA0-000	NUT, SELF-LOCK, 6MM	1	-	-	-----	BL,HX,HXQ,HXU,HX2,HX26,HX4,LD,LDB1,LDB2,LDN,LD4,LH,LHB2,LHP1,LHQ4 LJ,LJC1,LJG,LSJ,LVL,LX,LX2,LX4,NAX,NAX1,NDF1,NDJ,NJ,NJC1,NJG,NMB NTB,NTU,NW,NWA,NWB2,NX,PMX,PX,PXU,PX2,QA,QAB2,QA2,QD,QG,QG2,QH QHP1,QHQ4,QH26,QH4,QJF,QM,QSW4,QT,QTP,QTP2,QVL,QX,QXB2,QXC,QXC9 QXE,QXE2,QXE4,QXE6,QXE8,QXF,QXF2,QXH4,QXQ,QXS2,QXU,QX2,QX26,QX4 QX7,RG,RH,RHA2,RHQ4,RH2,RH26,RMG2,RX,RXU,RX2,RX4,SD,SDB1,SDB2,SDN SD4,SH,SHQ4,SJ,SJG,SMC4,SMG1,SMG2,SM11,SM12,SM14,SM21,SM22,SM24 SWG4,SX,SXE4,SXU,SX4,SX7,TX,TXE,TXU,TXU1,TX2,TX4,UX,VA2,VEE1 VGG2,VX,VX2,VX4
			1	-	-	1269858	VEE1
			-	1	1		



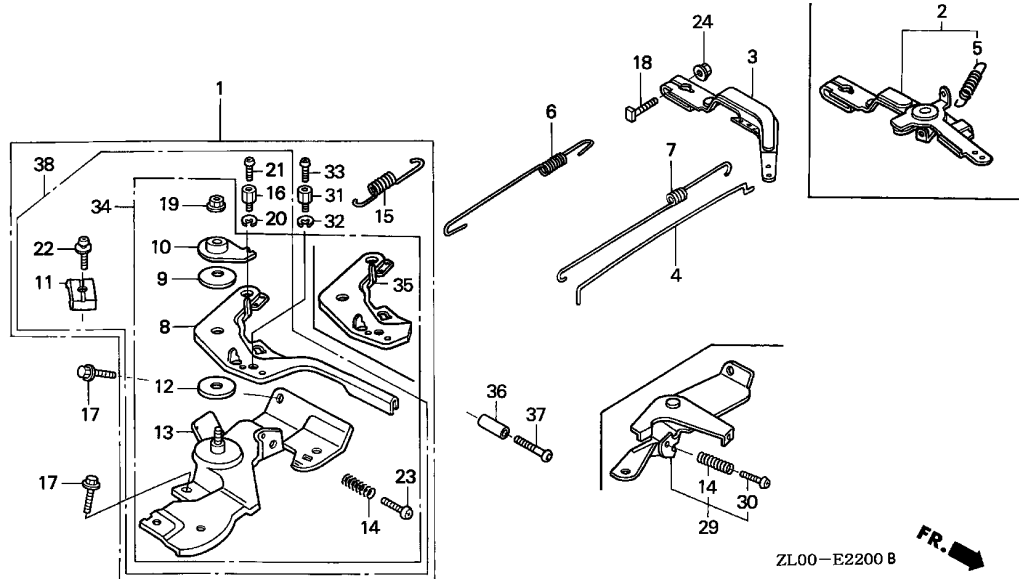

Ref. No.	Part No.	Description	Reqd. QTY			Serial No.	Parts catalogue code
			(1)	(2)	(3)		
20	90605-230-000	CIRCLIP, 5MM	1	-	-	LJ,LJC1,LJG,LSJ,NAX,NAX1,NDF1,NDJ,NJ,NJC1,NJG,NMB,NTB,NTU,NW,NWA,NWB2,QJF,QJF1,QSW4,QXC,QXC9,SJ,SJG,SMG1,SMG2,SM11,SM12,SM14,SM22,SM24,SWG4	
			1	-	-	1269858	VEE1
21	93500-04006-0H	SCREW, PAN, 4X6	1	-	-	LJ,LJC1,LJG,LSJ,NAX,NAX1,NDF1,NDJ,NJ,NJC1,NJG,NMB,NTB,NTU,NW,NWA,NWB2,QJF,QSW4,QXC,QXC9,SJ,SJG,SMG1,SMG2,SM11,SM12,SM14,SM22,SM24,SWG4	
			1	-	-	1269858	VEE1
22	93500-05016-0A	SCREW, PAN, 5X16	1	-	-	BL,HX,HXQ,HXU,HX2,HX26,HX4,LD,LDB1,LDB2,LDN,LD4,LH,LHB2,LHP1,LHQ4,LJ,LJC1,LJG,LSJ,LVL,LX,LX2,LX4,NAX,NAX1,NDF1,NDJ,NJ,NJC1,NJG,NMB,NTB,NTU,NW,NWA,NWB2,NX,QA,QAB2,QA2,QD,QG,QG2,QH,QHP1,QHQ4,QH26,QH4,QJF,QM,QSW4,QT,QTP,QTP2,QVL,QX,QXB2,QXC,QXC9,QXE,QXE2,QXE4,QXE6,QXF,QXF2,QXH4,QXQ,QXS2,QXU,QX2,QX26,QX4,QX7,RG,RH,RHA2,RHQ4,RH2,RH26,RMG2,RX,RXU,RX2,RX4,SD,SDB1,SDB2,SDN,SD4,SH,SHQ4,SJ,SJG,SMC4,SMG1,SMG2,SM11,SM12,SM14,SM21,SM22,SM24,SWG4,SX,SXE4,SXU,SX4,SX7	
			1	-	-	1269858	VEE1
			-	-	1		
23	93500-05025-0A	SCREW, PAN, 5X25	1	-	-	PMX,PX,PXU,PX2,QXE8,TX,TXE,TXU,TXU1,TX2,TX4,UX,VA2,VEN1,VES1,VGG2,VX,VX2,VX4	
			-	1	-		

ZL00-E2200 B



Ref. No.	Part No.	Description	Reqd. QTY			Serial No.	Parts catalogue code
			(1)	GX200 (2)	(3)		
23)	93500-05025-0H	SCREW, PAN, 5X25	1	-	-	-----	BL, HX, HXQ, HXU, HX2, HX26, HX4, LD, LDB1, LDB2, LDN, LD4, LH, LHB2, LHP1, LHQ4, LJ, LJC1, LJG, LSJ, LVL, LX, LX2, LX4, NAX, NAX1, NDF1, NDJ, NJ, NJC1, NJG, NMB, NTB, NTU, NW, NWA, NWB2, NX, QA, QAB2, QA2, QD, QG, QG2, QH, QHP1, QHQ4, QH26, QH4, QJF, QM, QSW4, QT, QTP, QTP2, QVL, QX, QXB2, QXC, QXC9, QXE, QXE2, QXE4, QXE6, QXF, QXF2, QXH4, QXQ, QXS2, QXU, QX2, QX26, QX4, QX7, RG, RH, RHA2, RHQ4, RH2, RH26, RMG2, RX, RXU, RX2, RX4, SD, SDB1, SDB2, SDN, SD4, SH, SHQ4, SJ, SJG, SMC4, SMG1, SMG2, SM11, SM12, SM14, SM21, SM22, SM24, SWG4, SX, SXE4, SXU, SX4, SX7
			1	-	-	-----	1113369 VEE1
	90121-ZE0-000	SCREW, LOCK PAN	1	-	-	-----	1113370 1269858 VEE1
24	94050-06000	NUT, FLANGE, 6MM	1	1	1	-----	
29	16570-ZB2-000	CONTROL ASSY.	1	-	-	-----	QJF1, VMG1, VNG4, VSD, VSD1, VSD2, VSD7, VS17, VXU, VXU1
	16570-ZL0-V90	1	-	-	-----	1269859 VEE1
30	90121-735-700	SCREW, LOCK PAN (5X35)	1	-	-	-----	1269859 VEE1
	93500-05035-0A	SCREW, PAN, 5X35	1	-	-	-----	QJF1, VMG1, VNG4, VSD, VSD1, VSD2, VSD7, VS17, VXU, VXU1
31	16594-883-010	HOLDER, WIRE	1	-	-	-----	SM21, SM22, SM24
			1	-	-	-----	1310620 SM11, SM12, SM14
32	90605-230-000	CIRCLIP, 5MM	1	-	-	-----	SM21, SM22, SM24
			1	-	-	-----	1310620 SM11, SM12, SM14
33	93500-04006-0H	SCREW, PAN, 4X6	1	-	-	-----	SM21, SM22, SM24
			1	-	-	-----	1310620 SM11, SM12, SM14
34	16500-ZH8-010	CONTROL ASSY. (STD.)	1	-	-	-----	TX4, UX
			1	-	-	-----	1180377 PMX, PX, PX2, TX, TXE, TX2, VA2, VGG2, VX, VX2, VX4
	16500-ZH8-020	CONTROL ASSY.	1	-	-	-----	1288719 PXU, TXU, TXU1
			1	-	-	-----	1180378 1288719 PMX, PX, TX, TXE, VX, VX4
			1	-	-	-----	1180378 1288955 PX2, TX2, VA2, VGG2, VX2
	16500-ZH8-030	1	-	-	-----	QXE8, VEN1, VES1
			1	-	-	-----	1288720 PMX, PX, PXU, TX, TXE, TXU, TXU1, VX, VX4
			1	-	-	-----	1288956 PX2, TX2, VA2, VGG2, VX2
			-	1	-	-----	
35	16571-ZH8-S02	LEVER, CONTROL	1	-	-	-----	NJC1
36	16599-ZG1-M10	COLLAR, STOPPER	(1)	(1)	-	-----	HX4, LD4, LHQ4, LX4, QG, QHQ4, QSW4, QXE4, QX4, QX7, RG, RHQ4, RX4, SD4, SHQ4, SMC4, SM14, SM24, SWG4, SXE4, SX4, SX7, TX4, VNG4, VSD, VSD1, VSD7, VS17, VX4, VX4P
37	90016-ZG9-N30	SCREW, RECESSED, 5X25	(1)	(1)	-	-----	HX4, LD4, LHQ4, LX4, QG, QHQ4, QSW4, QXE4, QX4, QX7, RG, RHQ4, RX4, SD4, SHQ4, SMC4, SM14, SM24, SWG4, SXE4, SX4, SX7, TX4, VNG4, VSD, VSD1, VSD7, VS17, VX4, VX4P
38	16500-ZH8-893	CONTROL ASSY. (REMOTE INTL-S)	1	-	-	-----	SWG4



E-22-20

AUTO THROTTLE

J 5

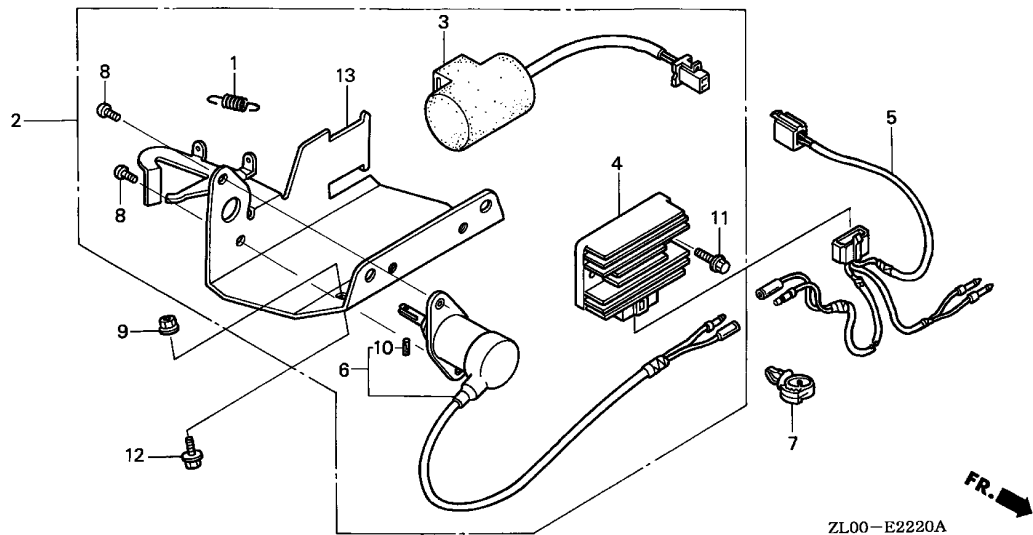

Ref. No.	L.O.N.	(Relative ref. Number) Description	F.R.T.
1	8101Q9	SPRING, CHOKE RETURN	0.1
2	8101S8	THROTTLE, AUTO	0.2
3	6141B1	CONDENSER UNIT	0.1
4	6131B7	RECTIFIER, REGULATOR	0.1
5	6111F0	SUB HARNESS, AUTO THROTTLE ...	0.1
6	6211C5	SOLENOID, AUTO THROTTLE	0.1

2

Ref. No.	Part No.	Description	Reqd. QTY			Serial No.	Parts catalogue code
			(1)	GX200 (2)	(3)		
1	16268-893-000	SPRING, CHOKE RETURN	1	-	-	VEN, VEN4, VES	
2	16270-ZLO-V30	THROTTLE ASSY., AUTO	1	-	-	VEN, VEN4	
	16270-ZLO-W50	1	-	-	VES	
3	31700-KAE-871	CONDENSER UNIT	1	-	-	VEN, VEN4	
4	31750-ZLO-V31	RECTIFIER ASSY., REGULATOR ..	1	-	-	VEN, VEN4	
5	32110-ZLO-V30	SUB HARNESS ASSY.	1	-	-	VEN, VEN4	
6	36330-ZLO-V31	SOLENOID ASSY., AUTO THROTTLE	1	-	-	VEN, VEN4, VES	
7	90683-SAO-003	CLIP, WIRE HARNESS, 25MM	2	-	-	VEN, VEN4, VES	
8	93500-05008-0A	SCREW, PAN, 5X8	2	-	-	VEN, VEN4, VES	
9	94050-06000	NUT, FLANGE, 6MM	2	-	-	VEN, VEN4, VES	
10	94305-20062	PIN, SPRING, 2X6	1	-	-	VEN, VEN4, VES	
11	95701-06016-00	BOLT, FLANGE, 6X16	2	-	-	VEN, VEN4	
12	95701-06025-00	BOLT, FLANGE, 6X25	2	-	-	VEN, VEN4, VES	
13	16273-ZLO-V30	LEVER, SOLENOID THROTTLE	1	-	-	VEN, VEN4, VES	

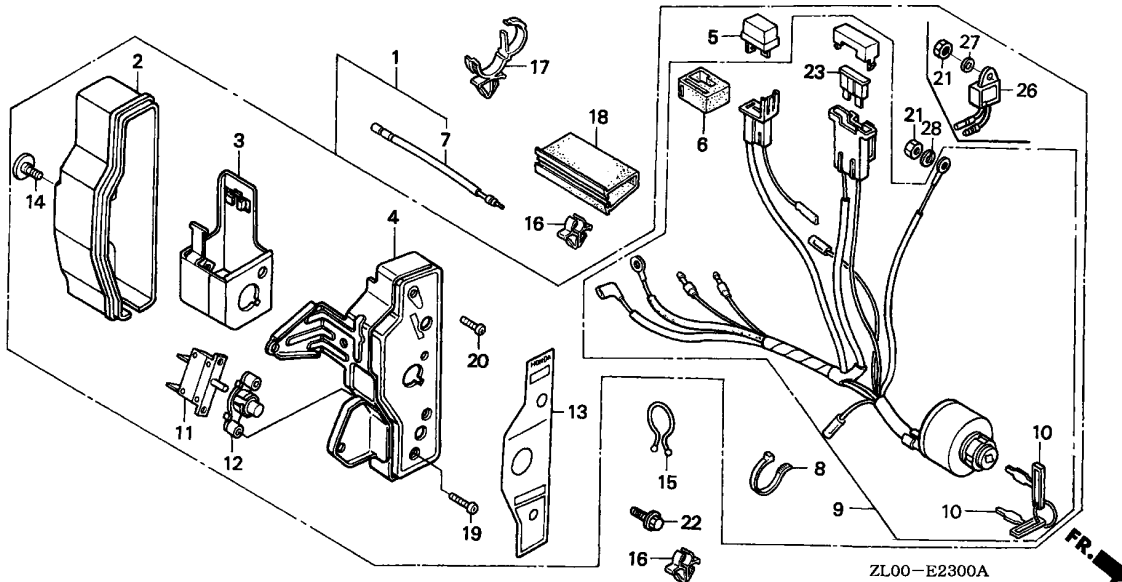

Ref. No.	L.O.N.	(Relative ref. Number) Description	F.R.T.
1		(7)	
1	6221A2	BOX, CONTROL	0.1
4	4131F9	PANEL, CONTROL	0.2
5	6131B8	RECTIFIER, SILICON	0.1
9	6151E1	SWITCH, COMBINATION	0.2
11	6221D4	PROTECTOR, CIRCUIT	0.2
23	8121A7	FUSE, BLADE	0.1
26	6151A0	ALERT UNIT, OIL	0.1

Ref. No.	Part No.	Description	Reqd. QTY			Serial No.	Parts catalogue code
			GX200	(1)	(2)		
1	31610-ZE1-834ZA	BOX ASSY., CONTROL (EXP-ALERT) *NH1*.....BLACK	1	-	-	----- QXE	
	31610-ZE1-834ZB	*R8*.....BRIGHT RED	1	-	-	1156270 QXE2	
			1	-	-	----- QXE	
			1	-	-	1156170 QXE6,TXE	
			1	-	-	1156270 QXE2	
	31610-ZE1-835ZA	*NH1*.....BLACK	1	-	-	1156271 ----- QXE2	
	31610-ZE1-835ZB	*R8*.....BRIGHT RED	1	-	-	1156171 ----- TXE	
			1	-	-	1829553 TXU1	
			1	-	-	1156171 1829553 QXE6	
			1	-	-	1156271 1829553 QXE2	
	31610-ZH8-R92ZA	BOX ASSY., CONTROL (EXP,10A) *R8*.....BRIGHT RED	1	-	-	1156170 QSW4	
	31610-ZH8-R93ZA	*R8*.....BRIGHT RED	1	-	-	1156171 ----- QSW4	
	31610-ZH8-W52ZB	BOX ASSY., CONTROL (EXTERNAL-10A) *R8*.....BRIGHT RED	1	-	-	1829719 QH4,QXH4	
			1	-	-	1156171 1829719 QTP2	
	31610-ZK8-W41ZA	BOX ASSY., CONTROL (EXTERNAL-ALERT) *R8*.....BRIGHT RED	1	-	-	1156170 QXE4,SXE4	
	31610-ZK8-W41ZB	*NH1*.....BLACK	1	-	-	1156170 QXE4	
	31610-ZK8-W42ZA	*R8*.....BRIGHT RED	1	-	-	1156171 1815067 QXE4,SXE4	
	31610-ZK8-W42ZB	*NH1*.....BLACK	1	-	-	1156171 ----- QXE4	
	31610-ZE1-835ZG	BOX ASSY., CONTROL (EXP-ALERT) *R280*.....POWER RED	1	-	-	----- QXE8	
			1	-	-	1829554 ----- QXE2,QXE6,TXU1	



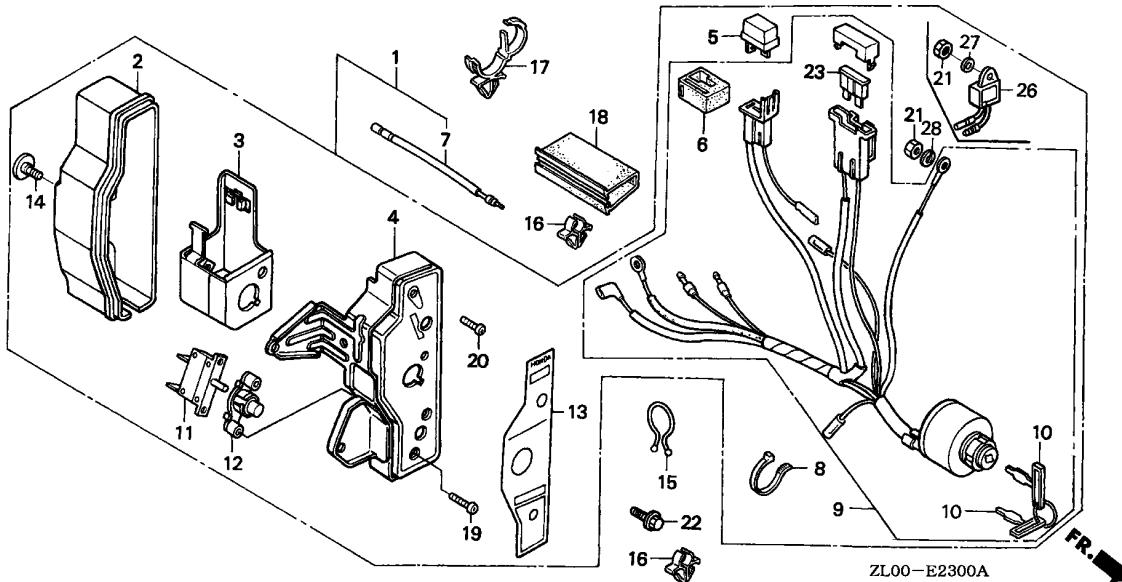

Ref. No.	Part No.	Description	Reqd. QTY			Serial No.	Parts catalogue code
			(1)	(2)	(3)		
(1)	31610-ZH8-W52ZE	BOX ASSY., CONTROL (EXTERNAL-10A)					
		R280.....POWER RED	1	-	-	1829720	----- QH4,QTP2,QXH4
	31610-ZK8-W42ZF	BOX ASSY., CONTROL (EXP-ALERT)					
		R280.....POWER RED	1	-	-	1815068	----- QXE4,SXE4
2	31612-ZE2-003	CASE, CONTROL	1	-	-	1156171	----- QH4,QSW4,QXE,QXE2,QXE4,QXE6,QXE8,QXH4,SXE4,TXE,TXU1
3	31614-ZE2-003	BRACKET, CASE MOUNTING	1	-	-	1156171	----- QTP2
4	31615-ZE1-003ZA	PANEL COMP., CONTROL					
		NH1.....BLACK	1	-	-	1814177	----- QXE,QXE4
	31615-ZE1-003ZB	*R8*.....BRIGHT RED	1	-	-	1814177	----- QSW4,QXE,TXE
			1	-	-	1156171	----- QH4,QXE2,QXE4,QXE6,QXH4,SXE4,TXU1
			1	-	-	1814177	----- QTP2
	31615-ZE1-003ZA	*NH1*.....BLACK	1	-	-	1814177	----- QXE2
	31615-ZE1-003ZG	*R280*.....POWER RED	1	-	-	1814178	----- QXE8
5	31700-124-008	RECTIFIER ASSY., SILICON (SHINDENGEN)	1	-	-	1814178	----- QH4,QTP2,QXE2,QXE4,QXE6,QXH4,SXE4,TXU1
			1	-	-		----- QXE,QXE2,QXE4,QXE6,QXE8,SXE4,TXE,TXU1
6	32127-738-700	SUSPENSION, COUPLER	1	-	-		----- QXE,QXE2,QXE4,QXE6,QXE8,SXE4,TXE,TXU1
7	32197-ZE1-003	SUB HARNESS	1	-	-	1156171	----- QH4,QSW4,QXE,QXE2,QXE4,QXE6,QXE8,QXH4,SXE4,TXE,TXU1
			1	-	-	1156171	----- QTP2
8	32902-892-003	BAND	1	-	-	1156171	----- QH4,QSW4,QXE,QXE2,QXE4,QXE6,QXE8,QXH4,SXE4,TXE,TXU1
			1	-	-	1156171	----- QTP2
9	35100-ZE1-812	SWITCH ASSY., COMBINATION	1	-	-		----- QXE,QXE2,QXE4,QXE6,QXE8,SXE4,TXE,TXU1
	35100-ZH8-R90	SWITCH ASSY., COMBINATION (10A CHG/RCM)	1	-	-	1156171	----- QH4,QSW4,QXH4
			1	-	-	1156171	----- QTP2

Ref. No.	Part No.	Description	Reqd. QTY			Serial No.	Parts catalogue code
			(1)	GX200 (2)	(3)		
10	35111-880-003	KEY COMP.	1	-	-	1960505	QXH4
			2	-	-		QSW4,QXE,QXE2,QXE4,QXE6,QXE8,SXE4,TXE,TXU1
			2	-	-	1960505	QH4
	35111-880-013	2	-	-	1156171	1960505 QTP2
			1	-	-	1960506	QXH4
			2	-	-	1960506	QH4,QTP2
11	38240-VA3-900	PROTECTOR, CIRCUIT (1.0A) ...	1	-	-		QXE,QXE2,QXE4,QXE6,QXE8,SXE4,TXE,TXU1
12	38250-ZA8-701	LENS ASSY., PROTECTOR	1	-	-		QXE,QXE2,QXE4,QXE6,QXE8,SXE4,TXE,TXU1
13	87529-ZE2-811	PANEL, CONTROL BOX (EXTERNAL)	1	-	-		QXE,QXE2,QXE6,QXE8,TXE,TXU1
	87529-ZE2-860	MARK, CONTROL BOX (EXTERNAL-REGULATOR)	1	-	-		QH4,QXH4
			1	-	-	1156171	QTP2
	87529-ZH8-W40	MARK, CONTROL BOX (ENGLISH) .	1	-	-		QSW4
	87529-ZH9-W40	1	-	-		QXE4,SXE4
14	90380-MA6-010	SCREW, SPECIAL, 6X12	1	-	-		QH4,QSW4,QXE,QXE2,QXE4,QXE6,QXE8,QXH4,SXE4,TXE,TXU1
			1	-	-	1156171	QTP2
15	90630-751-000	CLIP, PURSE LOCK	1	-	-		QH4,QSW4,QXE,QXE2,QXE4,QXE6,QXE8,QXH4,SXE4,TXE,TXU1
16	90682-ZE1-000	CLIP, CORD	2	-	-		QH4,QSW4,QXE,QXE2,QXE4,QXE6,QXE8,QXH4,SXE4,TXE,TXU1
17	90690-SAO-003	STRAP, WIRE HARNESS, 25MM (BLACK)	1	-	-		QH4,QSW4,QXE,QXE2,QXE4,QXE6,QXE8,QXH4,SXE4,TXE,TXU1
18	91406-ZE2-003	TUBE, FASTENER, 30MM	1	-	-		QH4,QSW4,QXE,QXE2,QXE4,QXE6,QXE8,QXH4,SXE4,TXE,TXU1
			1	-	-	1156171	QTP2
19	93500-03012-OH	SCREW, PAN, 3X12	2	-	-		QXE,QXE2,QXE4,QXE6,QXE8,SXE4,TXE,TXU1
20	93500-04012-OH	SCREW, PAN, 4X12	1	-	-		QH4,QSW4,QXE,QXE2,QXE4,QXE6,QXE8,QXH4,SXE4,TXE,TXU1
			1	-	-	1156171	QTP2
21	94001-04390-0S	NUT, HEX., 4MM	1	-	-		QXE
			1	-	-	1156170	QSW4,QXE4,QXE6,SXE4,TXE
			1	-	-	1156270	QXE2
			2	-	-		QXE8
			2	-	-		QH4,QXE8,QXH4,TXU1
			2	-	-	1156171	QSW4,QTP2,QXE4,QXE6,SXE4,TXE
			2	-	-	1156271	QXE2
22	95701-06010-00	BOLT, FLANGE, 6X10	1	-	-		QH4,QSW4,QXE,QXE2,QXE4,QXE6,QXE8,QXH4,SXE4,TXE,TXU1
			1	-	-	1156171	QTP2
23	98200-30500	FUSE, BLADE (5A)	1	-	-		QXE,QXE2,QXE4,QXE6,QXE8,SXE4,TXE,TXU1
	98200-31500	FUSE, BLADE (15A)	1	-	-		QH4,QSW4,QXH4
			1	-	-	1156171	QTP2
26	34150-ZH7-003	ALERT UNIT, OIL	1	-	-		QH4,QXE8,QXH4,TXU1
			1	-	-	1156171	QSW4,QTP2,QXE4,QXE6,SXE4,TXE
			1	-	-	1156271	QXE2
27	94101-04800	WASHER, PLAIN, 4MM	1	-	-		QH4,QXE8,QXH4,TXU1
			1	-	-	1156171	QSW4,QTP2,QXE4,QXE6,SXE4,TXE
			1	-	-	1156271	QXE2
28	94111-04800	WASHER, SPRING, 4MM	1	-	-		QH4,QXE8,QXH4,TXU1
			1	-	-	1156171	QSW4,QTP2,QXE4,QXE6,SXE4,TXE
			1	-	-	1156271	QXE2

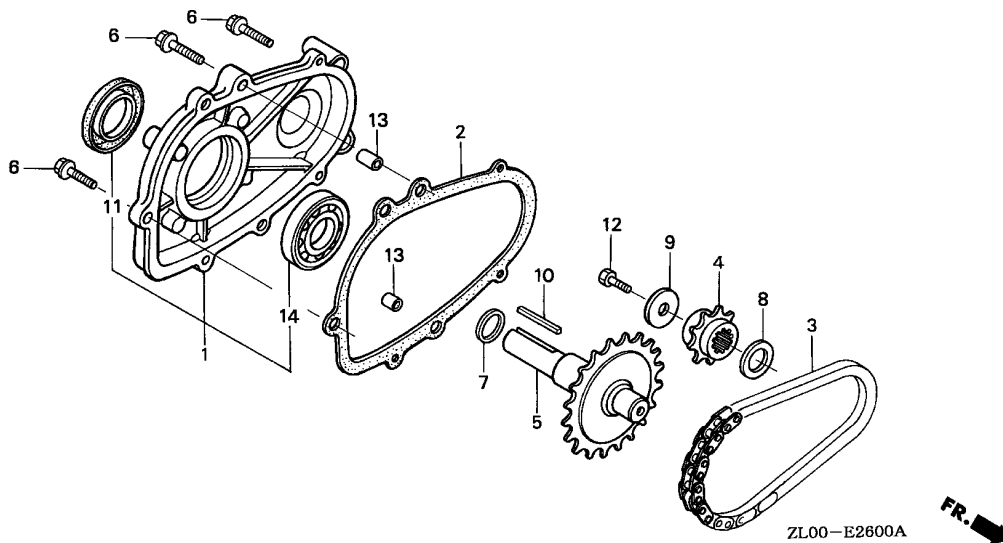

Ref. No.	L.O.N.	(Relative ref. Number) Description	F.R.T.
1		(2)	
1	1101B2	COVER, CHAIN CASE AND/OR PACKING, CHAIN CASE COVER ...	0.2
3	2141C3	CHAIN, POWER TAKE OFF DRIVE ..	0.3
4	2141J8	SPROCKET, DRIVE	0.3
5	2141H4	SHAFT, POWER TAKE OFF	0.3
11	2141F2	OIL SEAL, POWER TAKE OFF SHAFT	0.2
14	2141A8	BEARING, POWER TAKE OFF SHAFT	0.3

Ref. No.	Part No.	Description	Reqd. QTY			Serial No.	Parts catalogue code
			(1)	GX200 (2)	(3)		
1	11500-ZE1-610	COVER ASSY., CHAIN CASE	1	-	-	LD,LDB1,LDB2,LDN,LD4,LSJ,LX	
			1	-	-	1854386 LH,LHB2,LHP1,LHQ4,LJ,LJC1,LJG,LVL,LX2,LX4	
	11500-ZE1-611	1	-	-	1854387 LH,LHB2,LHP1,LHQ4,LJ,LJC1,LJG,LVL,LX2,LX4	
2	11521-ZH8-800	PACKING, CHAIN CASE COVER ...	1	-	-	LD,LDB1,LDB2,LDN,LD4,LH,LHB2,LHP1,LHQ4,LJ,LJC1,LJG,LSJ,LVL,LX,LX2,LX4	
			-	-	1		
3	14411-ZE1-611	CHAIN, P.T.O. DRIVE (DID317FM2-34LE)	1	-	-	LD,LDB1,LDB2,LDN,LD4,LH,LHP1,LHQ4,LJ,LJC1,LJG,LSJ,LX,LX2,LX4	
			1	-	-	1289073 LHB2	
	14411-ZF1-611	1	-	-	LVL	
			1	-	-	1289074 LHB2	
4	23110-ZE1-610	SPROCKET, DRIVE (13T)	1	-	-	LD,LDB1,LDB2,LDN,LD4,LH,LHB2,LHP1,LHQ4,LJ,LJC1,LJG,LSJ,LVL,LX,LX2,LX4	
			-	-	1		
5	23710-ZE1-613	SHAFT, P.T.O. (26T)	1	-	-	LD,LDB1,LDB2,LDN,LD4,LH,LHB2,LHP1,LHQ4,LJ,LJC1,LJG,LSJ,LVL,LX,LX2,LX4	
			-	-	1		
6	90015-883-000	BOLT, FLANGE, 6X28	5	-	-	LD,LDB1,LDB2,LDN,LD4,LH,LHB2,LHP1,LHQ4,LJ,LJC1,LJG,LSJ,LVL,LX,LX2,LX4	
			-	-	5		
7	90456-ZE1-000	SPRING, THRUST	1	-	-	LD,LDB1,LDB2,LDN,LD4,LH,LHB2,LHP1,LHQ4,LJ,LJC1,LJG,LSJ,LVL,LX,LX2,LX4	
			-	-	1		
8	90470-ZE1-000	SPACER, 20MM	1	-	-	LD,LDB1,LDB2,LDN,LD4,LH,LHB2,LHP1,LHQ4,LJ,LJC1,LJG,LSJ,LVL,LX,LX2,LX4	
			-	-	1		

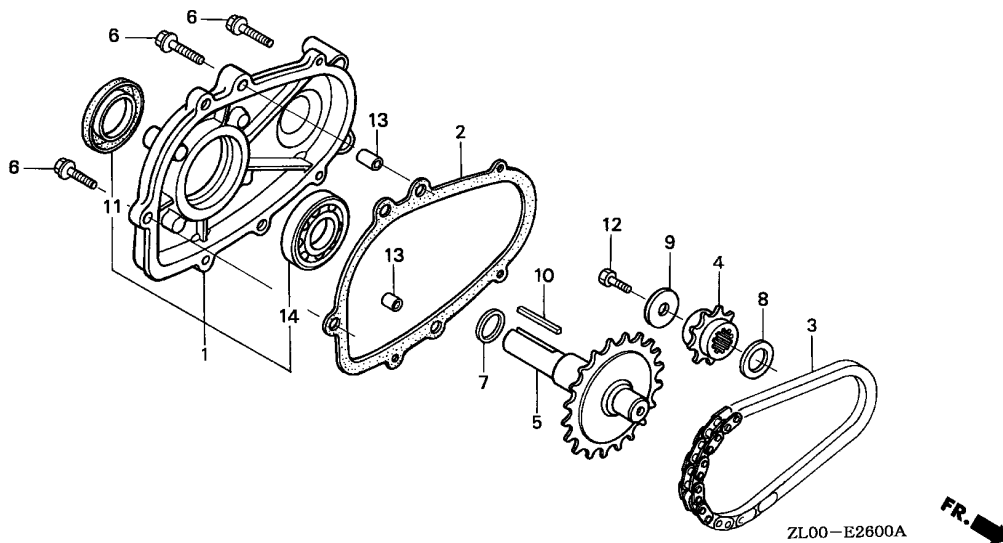

Ref. No.	Part No.	Description	Reqd. QTY			Serial No.	Parts catalogue code
			(1)	GX200 (2)	(3)		
9	90471-ZE1-610	WASHER, 8MM	1	-	-	LD,LDB1,LDB2,LDN,LD4,LH,LHB2,LHP1,LHQ4,LJ,LJC1,LJG,LSJ,LVL,LX,LX2 LX4	
10	90741-883-810	KEY, 5X5X33(YELLOW)	1	-	1	LD,LDB1,LDB2,LDN,LD4,LH,LHB2,LHP1,LHQ4,LJ,LJC1,LJG,LSJ,LVL,LX,LX2 LX4	
11	91202-883-005	OIL SEAL, 25X41X6	1	-	-	LD,LDB1,LDB2,LDN,LD4,LSJ,LX	
	91201-Z0T-801		1	-	-	1854386 LH,LHB2,LHP1,LHQ4,LJ,LJC1,LJG,LVL,LX2,LX4	
12	92101-08025-0A	BOLT, HEX., 8X25	1	-	1	1854387 LH,LHB2,LHP1,LHQ4,LJ,LJC1,LJG,LVL,LX2,LX4	
			1	-	-	LD,LDB1,LDB2,LDN,LD4,LH,LHB2,LHP1,LHQ4,LJ,LJC1,LJG,LSJ,LVL,LX,LX2 LX4	
13	94301-08140	DOWEL PIN, 8X14	2	-	1	LD,LDB1,LDB2,LDN,LD4,LH,LHB2,LHP1,LHQ4,LJ,LJC1,LJG,LSJ,LVL,LX,LX2 LX4	
14	96100-62050-00	BEARING, RADIAL BALL, 6205	1	-	2	LD,LDB1,LDB2,LDN,LD4,LH,LHB2,LHP1,LHQ4,LJ,LJC1,LJG,LSJ,LVL,LX,LX2 LX4	
			-	-	1		



E-26-1

REDUCTION(2)

J11

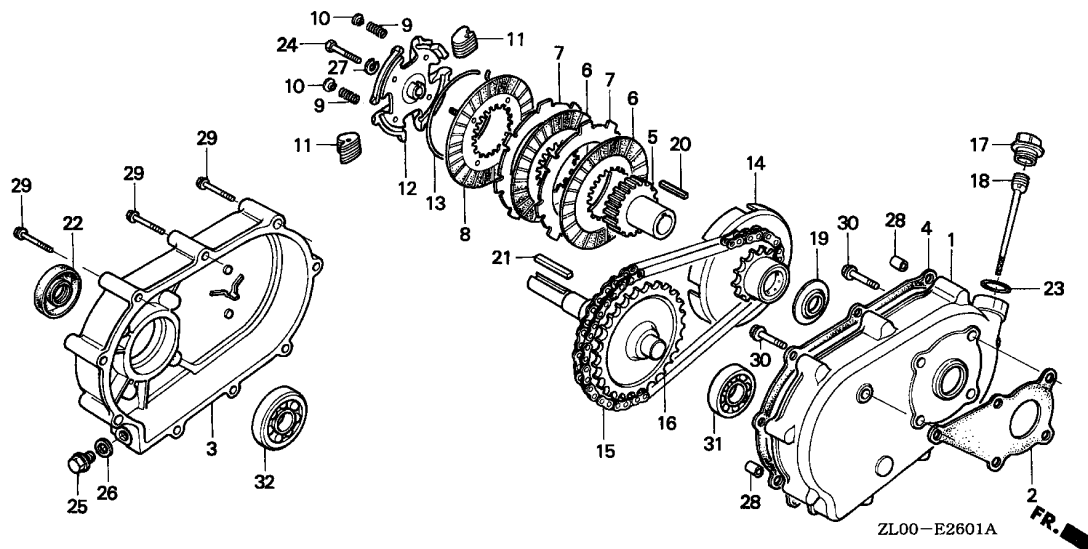

Ref. No.	L.O.N.	(Relative ref. Number) Description	F.R.T.
1	2141C1	CASE, REDUCTION	0.3
3		(4)	
	2141D0	COVER, REDUCTION AND/OR PACKING, REDUCTION COVER	0.3
5	2121A7	CENTER, CLUTCH	0.3
6	2101G4	DISK, CLUTCH FRICTION	0.3
7	2121C2	PLATE, CLUTCH	0.3
8	2101U7	PLATE, CLUTCH PRESSURE	0.3
15	2141C2	CHAIN, DRIVE	0.3
16	2141H4	SHAFT, POWER TAKE OFF	0.3
22	2141L3	OIL SEAL, POWER TAKE OFF SHAFT (A)	0.3
31	2141A7	BEARING, POWER TAKE OFF SHAFT :FRONT	0.4
32	2141L0	BEARING, POWER TAKE OFF SHAFT :REAR	0.4

Ref. No.	Part No.	Description	Reqd. QTY			Serial No.	Parts catalogue code
			(1)	(2)	(3)		
1	21510-883-621	CASE, REDUCTION	1	-	-	RG, RH, RHA2, RHQ4, RH2, RH26, RMG2, RX, RXU, RX2, RX4	
2	21591-ZH8-620	PACKING, REDUCTION CASE	1	-	-	RG, RH, RHA2, RHQ4, RH2, RH26, RMG2, RX, RXU, RX2, RX4	
3	21610-822-611	COVER, REDUCTION	1	-	-	RG, RH, RHA2, RHQ4, RH2, RH26, RMG2, RX, RXU, RX2, RX4	
4	21691-ZH8-800	PACKING, REDUCTION COVER	1	-	-	RG, RH, RHA2, RHQ4, RH2, RH26, RMG2, RX, RXU, RX2, RX4	
5	22121-883-620	CENTER, CLUTCH	1	-	-	RG, RH, RHA2, RHQ4, RH2, RH26, RMG2, RX, RXU, RX2, RX4	
6	22201-822-610	DISK, CLUTCH FRICTION	2	-	-	RG, RH, RHA2, RHQ4, RH2, RH26, RMG2, RX, RXU, RX2, RX4	
7	22311-822-610	PLATE, CLUTCH	2	-	-	RG, RH, RHA2, RHQ4, RH2, RH26, RMG2, RX, RXU, RX2, RX4	
8	22350-822-610	PLATE COMP., CLUTCH PRESSURE	1	-	-	RG, RH, RHA2, RHQ4, RH2, RH26, RMG2, RX, RXU, RX2, RX4	
9	22411-822-611	SPRING, CLUTCH FREE	4	-	-	RG, RH, RHA2, RHQ4, RH2, RH26, RMG2, RX, RXU, RX2, RX4	
10	22421-822-610	HOLDER, CLUTCH SPRING	4	-	-	RG, RH, RHA2, RHQ4, RH2, RH26, RMG2, RX, RXU, RX2, RX4	
11	22521-822-610	WEIGHT, CLUTCH	48	-	-	RG, RH, RHA2, RHQ4, RH2, RH26, RMG2, RX, RXU, RX2, RX4	
12	22531-883-620	HOLDER, CLUTCH WEIGHT	1	-	-	RG, RH, RHA2, RHQ4, RH2, RH26, RMG2, RX, RXU, RX2, RX4	
13	22535-822-610	CENTER, CLUTCH WEIGHT	1	-	-	RG, RH, RHA2, RHQ4, RH2, RH26, RMG2, RX, RXU, RX2, RX4	
14	23120-883-620	SPROCKET COMP., DRIVE	1	-	-	RG, RH, RHA2, RHQ4, RH2, RH26, RMG2, RX, RXU, RX2, RX4	
15	23161-822-611	CHAIN, DRIVE (RK428SH-36LE)	1	-	-	RG, RH, RHA2, RHQ4, RH2, RH26, RMG2, RX, RXU, RX2, RX4	
16	23711-822-610	SHAFT COMP., P.T.O. (28T)	1	-	-	RG, RH, RHA2, RHQ4, RH2, RH26, RMG2, RX, RXU, RX2, RX4	
17	25620-805-611	CAP, REDUCTION OIL (BLACK)	1	-	-	RG, RH, RHA2, RHQ4, RH2, RH26, RMG2, RX, RXU, RX2, RX4	
	25620-805-612	CAP, REDUCTION OIL (GRAY)	1	-	-	RH, RHA2, RHQ4, RH2, RH26, RMG2, RX, RXU, RX2, RX4	
18	25651-883-621	GAUGE, OIL LEVEL	1	-	-	RG, RH, RHA2, RHQ4, RH2, RH26, RMG2, RX, RXU, RX2, RX4	
19	90403-883-620	WASHER, THRUST, 20MM	1	-	-	RG, RH, RHA2, RHQ4, RH2, RH26, RMG2, RX, RXU, RX2, RX4	
20	90741-883-621	KEY, 5MM	1	-	-	RG, RH, RHA2, RHQ4, RH2, RH26, RMG2, RX, RXU, RX2, RX4	
21	90741-889-810	KEY, 7X7X33(YELLOW)	1	-	-	RG, RH, RHA2, RHQ4, RH2, RH26, RMG2, RX, RXU, RX2, RX4	
22	91202-805-610	OIL SEAL (PJ30507)	1	-	-	RG, RH, RHA2, RHQ4, RH2, RH26, RMG2, RX, RXU, RX2, RX4	
23	91301-805-000	O-RING, 26X2.7	1	-	-	RG, RH, RHA2, RHQ4, RH2, RH26, RMG2, RX, RXU, RX2, RX4	
24	92101-08035-0A	BOLT, HEX., 8X35	1	-	-	RG, RH, RHA2, RHQ4, RH2, RH26, RMG2, RX, RXU, RX2, RX4	

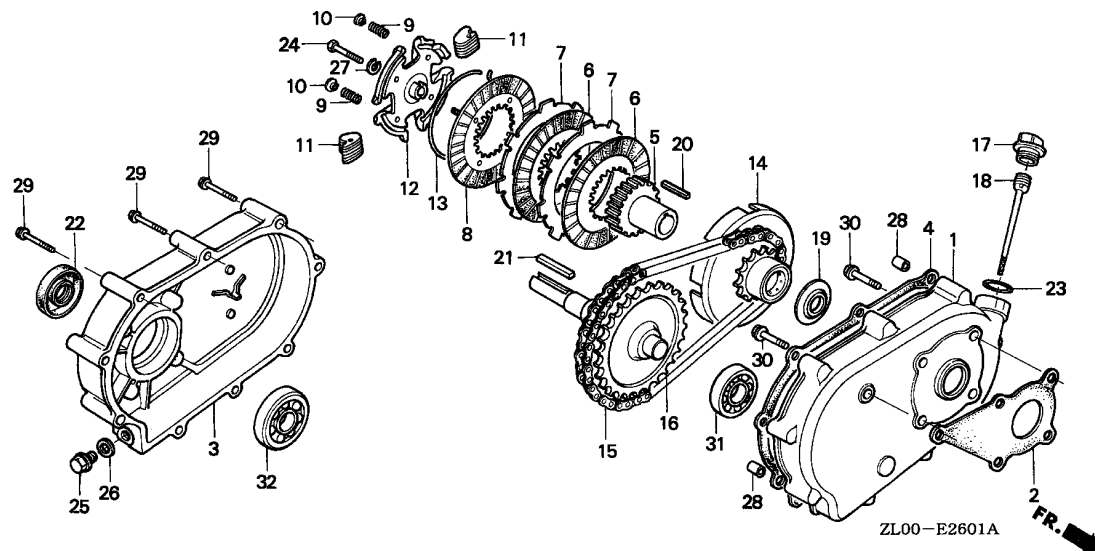

Ref. No.	Part No.	Description	Reqd. QTY			Serial No.	Parts catalogue code
			(1)	(2)	(3)		
25	92800-12000	BOLT, DRAIN PLUG, 12MM	1	-	-	-----	RG,RH,RHA2,RHQ4,RH2,RH26,RMG2,RX,RXU,RX2,RX4
26	94109-12000	WASHER, DRAIN PLUG, 12MM	1	-	-	-----	RG,RH,RHA2,RHQ4,RH2,RH26,RMG2,RX,RXU,RX2,RX4
27	94111-08000	WASHER, SPRING, 8MM	1	-	-	-----	RG,RH,RHA2,RHQ4,RH2,RH26,RMG2,RX,RXU,RX2,RX4
28	94301-08100	DOWEL PIN, 8X10	2	-	-	-----	RG,RH,RHA2,RHQ4,RH2,RH26,RMG2,RX,RXU,RX2,RX4
29	95701-06055-00	BOLT, FLANGE, 6X55	9	-	-	-----	RG,RH,RHA2,RHQ4,RH2,RH26,RMG2,RX,RXU,RX2,RX4
30	95701-08022-00	BOLT, FLANGE, 8X22	5	-	-	-----	RG,RH,RHA2,RHQ4,RH2,RH26,RMG2,RX,RXU,RX2,RX4
31	96100-62050-00	BEARING, RADIAL BALL, 6205 ..	1	-	-	-----	RG,RH,RHA2,RHQ4,RH2,RH26,RMG2,RX,RXU,RX2,RX4
32	96100-62060-00	BEARING, RADIAL BALL, 6206 ..	1	-	-	-----	RG,RH,RHA2,RHQ4,RH2,RH26,RMG2,RX,RXU,RX2,RX4



E-26-2

REDUCTION(3)

J13

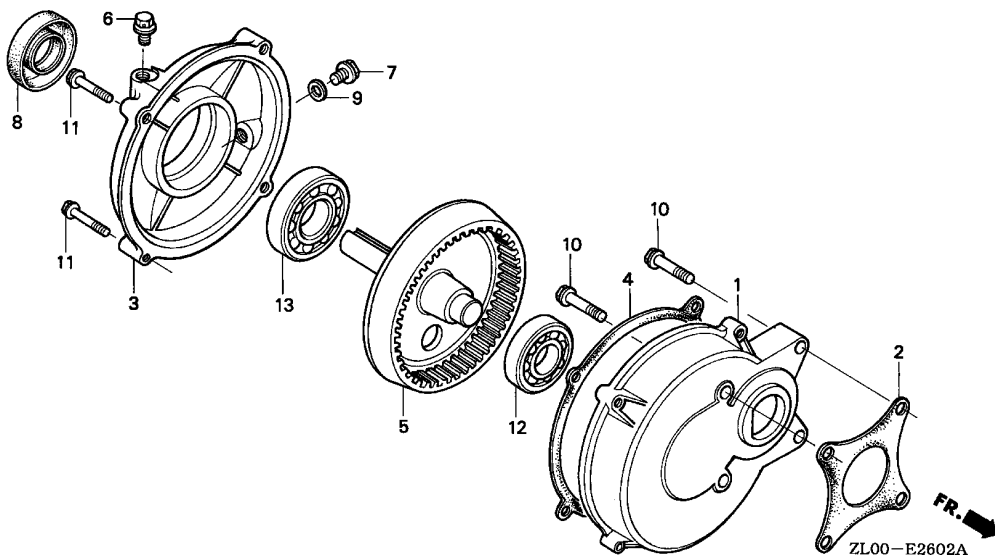

Ref. No.	L.O.N.	(Relative ref. Number) Description	F.R.T.
1	(2,4)		
1	2141L8	CASE, REDUCTION(A)	0.2
3	2141L9	COVER, REDUCTION AND/OR PACKING, REDUCTION COVER(A)	0.2
5	2141M0	SHAFT, POWER TAKE OFF(A)	0.2
8	2141M4	OIL SEAL, POWER TAKE OFF SHAFT (B)	0.2
12	2141L6	BEARING, POWER TAKE OFF SHAFT (A) :FRONT	0.3
13	2141L7	BEARING, POWER TAKE OFF SHAFT (A) :REAR	0.3

Ref. No.	Part No.	Description	Reqd. QTY			Serial No.	Parts catalogue code
			(1)	GX200 (2)	(3)		
1	21521-883-741	CASE, REDUCTION	1	-	-	HX, HXQ, HXU, HX2, HX26, HX4	
2	21591-ZH8-740	PACKING, REDUCTION CASE	1	-	-	HX, HXQ, HXU, HX2, HX26, HX4	
3	21621-883-741	COVER, REDUCTION	1	-	-	HX, HXQ, HXU, HX2, HX26, HX4	
4	21692-ZH8-800	PACKING, REDUCTION COVER	1	-	-	HX, HXQ, HXU, HX2, HX26, HX4	
5	23710-883-740	SHAFT, P.T.O.	1	-	-	HX, HXQ, HXU, HX2, HX26, HX4	
6	90002-883-740	BOLT, BREATHING	1	-	-	HX, HXQ, HXU, HX2, HX26, HX4	
7	90131-883-000	BOLT, DRAIN PLUG, 12X15	1	-	-	HX, HXQ, HXU, HX2, HX26, HX4	
8	91202-883-005	OIL SEAL, 25X41X6	1	-	-	HX, HXQ, HXU, HX2, HX26, HX4	
9	94109-12000	WASHER, DRAIN PLUG, 12MM	1	-	-	HX, HXQ, HXU, HX2, HX26, HX4	
10	95701-08032-08	BOLT, FLANGE, 8X32	4	-	-	HX, HXQ, HXU, HX2, HX26, HX4	
11	95701-08035-00	BOLT, FLANGE, 8X35	4	-	-	HX, HXQ, HXU, HX2, HX26, HX4	
12	96100-62040-00	BEARING, RADIAL BALL, 6204 ..	1	-	-	HX, HXQ, HXU, HX2, HX26, HX4	
13	96100-63050-00	BEARING, RADIAL BALL, 6305 ..	1	-	-	HX, HXQ, HXU, HX2, HX26, HX4	

E-26-3

REDUCTION(4)

J14

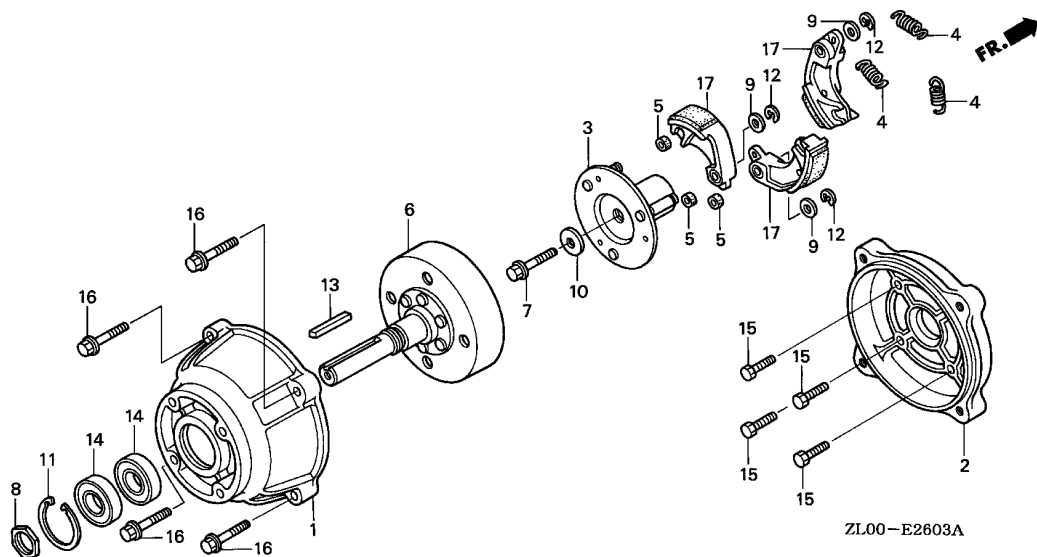

Ref. No.	L.O.N.	(Relative ref. Number) Description	F.R.T.
1	2121B2	COVER, CLUTCH	0.2
2	2121A6	CASE, CLUTCH	0.3
3	2141M7	PLATE, REDUCTION DRIVE	0.3
6	2141M0	SHAFT, POWER TAKE OFF(A)	0.2
14	2141M2	BEARING, POWER TAKE OFF SHAFT (A)	0.2
	2141M2A	.For two add	0.1
17	2141M8	WEIGHT SET, CLUTCH	0.3
.NOTE: Same time for two units or more			

Ref. No.	Part No.	Description	Reqd. QTY			Serial No.	Parts catalogue code
			(1)	(2)	(3)		
1	21121-ZL0-W80	COVER, CLUTCH	1	-	-	-----	BL
2	21512-ZL0-W80	CASE, CLUTCH	1	-	-	-----	BL
3	22350-ZL0-W81	PLATE COMP., DRIVE	1	-	-	-----	BL
4	22401-ZL0-W81	SPRING, CLUTCH	3	-	-	-----	BL
5	22804-148-000	RUBBER, CLUTCH DAMPER	3	-	-	-----	BL
6	23150-ZL0-W81	SHAFT COMP., P.T.O.	1	-	-	-----	BL
7	90101-GBL-000	BOLT, FLANGE, 8X35	1	-	-	-----	BL
8	90202-881-000	NUT, LOCK, 24MM	1	-	-	-----	BL
9	90442-KG8-000	WASHER, 9X16X1.4	3	-	-	-----	BL
10	90471-435-770	WASHER, 8MM	1	-	-	-----	BL
11	90602-ZL0-W80	CIRCLIP, INTERNAL, 47	1	-	-	-----	BL
12	90605-166-720	CIRCLIP, 7MM	3	-	-	-----	BL
13	90745-ZE1-600	KEY, 4.78X4.78X38	1	-	-	-----	BL
14	91008-ZL0-W81	BEARING, RADIAL BALL, 6005 ..	2	-	-	-----	BL
15	95701-08022-00	BOLT, FLANGE, 8X22	4	-	-	-----	BL
16	95701-08035-00	BOLT, FLANGE, 8X35	4	-	-	-----	BL
17	22010-ZL0-W80	WEIGHT SET, CLUTCH	1	-	-	-----	BL

2

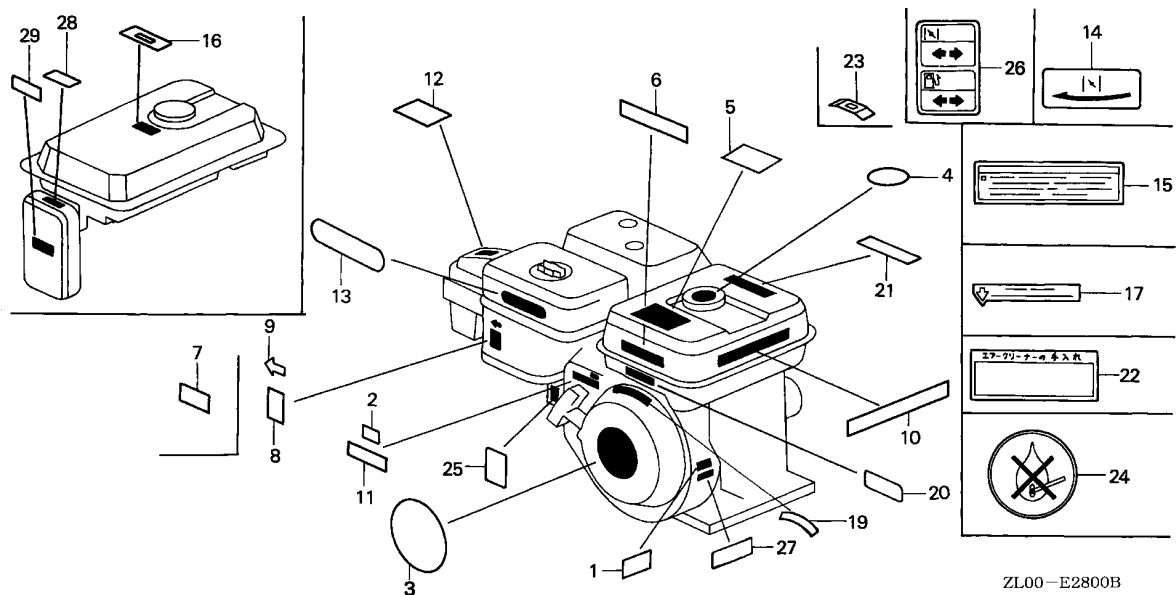

Ref. L.O.N. (Relative ref. Number) F.R.T.
No. Description

NO INFORMATION

ZL00-E2800B

Ref. No.	Part No.	Description	Reqd. QTY			Serial No.	Parts catalogue code
			(1)	(2)	(3)		
1	87152-ZL0-000	LABEL, SPECIFICATION (INTERNAL)	1	-	-	1740594	QJF,QJF1,SJ,SJG,SMG1,SMG2,SM11,SM21,VEN,VES,VES1,VMG1
	87152-ZL0-820	1	-	-	-----	LSJ,NAX,NAX1
	87152-ZL0-010	LABEL, SPECIFICATION (INTERNAL)	1	-	-	1743006	LJ,LJC1,LJG,NJ,NJG,NMB,NTB
	87152-ZL0-820	LABEL, SPECIFICATION	1	-	-	1740595	QJF,QJF1,SJ,SJG,SMG1,SMG2,SM11,SM21,VEN,VES,VES1,VMG1
2	87124-ZV3-010	MARK, EMERGENCY SWITCH INDICATION	-	1	-	1743007	LJ,LJC1,LJG,NJ,NJG,NMB,NTB
3	87521-ZL0-W80	EMBLEM	1	-	-	-----	BL
	87521-ZL0-000	1	-	-	-----	HX,HXQ,HXU,HX2,HX26,HX4,LD,LDB1,LDB2,LDN,LD4,LH,LHB2,LHP1,LHQ4 LJC1,LSJ,LX,LX2,LX4,NAX,NAX1,NDF1,NDJ,NJ,NJC1,NJG,NMB,NTB,NW,NWA NWB2,NX,PMX,PX,PXU,PX2,QA,QAB2,QA2,QD,QG,QH,QHP1,QHQ4,QH26,QH4 QJF,QM,QSW4,QT,QTP,QX,QXC,QXC9,QXE,QXE2,QXE4,QXE6,QXF,QXF2,QXQ QXS2,QXU,QX2,QX26,QX4,RG,RH,RHA2,RHQ4,RH2,RH26,RX,RXU,RX4,SD,SDB1 SDB2,SDN,SD4,SH,SHQ4,SJ,SJG,SMC4,SMG1,SM11,SM14,SM21,SM24,SX,SXE4 SXU,SX4,TX,TXE,TXU,TXU1,TX2,TX4,UX,VAA,VAA1,VA2,VEE1,VEN,VEN4 VMG1,VMT,VNG4,VSD,VSD1,VX,VXU,VXU1,VX2,VX4
			1	-	-	1593165	QG2,QTP2,RMG2,SM12,SM22,VGG2
	87521-ZL0-010	1	-	-	1812502	LJ,LJG,NMB,QXB2,QXH4,QX7,SWG4,SX7,VEN1,VSD2,VSD7,VS17
	87521-ZK0-800	1	-	-	1593166	1812502 QG2,QTP2,RMG2,SM12,SM22,VGG2
	87521-ZL0-020	1	-	-	1812939	LVL,QVL
			1	-	-	-----	QXE8,RX2
			1	-	-	1812503	LJ,LJG,NJ,NMB,QG2,QTP2,QXB2,QXH4,QX7,RMG2,SJ,SM12,SM22,SWG4,SX7 VEN1,VGG2,VSD2,VSD7,VS17
	87521-ZK0-801	1	-	-	1812940	LVL,QVL
4	87522-ZE1-810	MARK, CAUTION	1	-	-	-----	BL,LDB1,LDB2,LHB2,LVL,QAB2,QT,QVL,SDB1,SDB2
			1	-	-	1003701	QXC9

Ref. No.	Part No.	Description	Reqd. QTY			Serial No.	Parts catalogue code
			(1)	GX200 (2)	(3)		
(4)	87106-ZH8-S00	MARK, FUEL CAUTION (SHJ)	-	-	1		
5	87522-ZH8-W40	MARK, CAUTION	1	1	-	-----	HX4,LD4,LHQ4,LX4,QG,QHQ4,QH4,QSW4,QXB2,QXE4,QXH4,QX4,QX7,RG,RHQ4,RX4,SD4,SHQ4,SMC4,SM14,SM24,SWG4,SXE4,SX4,SX7,TX4,VNG4,VSD,VSD7,VX4,VX4P
	87522-ZB3-K01	MARK, FIRE DANGER	-	-	1		
6	87101-733-000	MARK, TOP	-	-	1		
	87520-ZH8-000	MARK A, COMBINATION	1	-	-	-----	LJC1,LSJ,NMB,NTB,QJF,QJF1,SM11,SM21,VEE1,VEN1,VES1,VMG1
			1	-	-	1012988	LJ,LJG,NJ,NJG,SJ,SJG
			1	-	-	1044773	VEN
	87522-ZH9-000	LABEL, CAUTION	1	-	-	-----	HXQ,LDN,NWA,NWB2,PX2,QA,QA2,QXF,QXF2,QXQ,SDN,VA2
	87522-ZH9-820	LABEL, CAUTION (THAI)	1	-	-	-----	QT
	87522-ZH9-010	LABEL, CAUTION	1	1	-	-----	BL,HX,HXU,HX2,HX26,LD,LDB1,LDB2,LH,LHB2,LHP1,LX,LX2,NDF1,NDJ,NW,NX,PMX,PX,PXU,QAB2,QD,QG2,QH,QHP1,QH26,QM,QTP,QTP2,QX,QXC,QXC9,QXE,QXE2,QXE6,QXE8,QXS2,QXU,QX2,QX26,RH,RH2,RH26,RMG2,RX,RXU,RX2,SD,SDB1,SDB2,SH,SM12,SM22,SX,SXU,TX,TEX,TXU,TXU1,TX2,UX,VGG2,VX,VXP,VXU,VXU1,VX2
7	87524-883-690	MARK, AIR CLEANER CAUTION (OIL BATH) (ARABIC)	1	-	-	-----	QT
8	87528-ZE1-810	MARK, CHOKE	1	-	-	-----	BL,HX,HXQ,HXU,HX2,HX26,LDN,LH,LHB2,LHP1,LJ,LJC1,LJG,LSJ,LVL,LX,LX2,NDF1,NDJ,NJ,NJG,NW,NWA,NWB2,NX,PMX,PX,PXU,PX2,QA,QAB2,QA2,QG2,QH,QHP1,QH26,QJF,QTP,QVL,QX,QXB2,QXC,QXC9,QXE,QXE2,QXE6,QXE8,QXF,QXF2,QXQ,QXS2,QXU,QX2,QX26,RH,RHA2,RH2,RH26,RMG2,RX,RXU,RX2,SDN,SH,SJ,SJG,SM11,SM12,SM21,SM22,SX,SXU,TX,TEX,TXU,TXU1,TX2,UX,VA2,VEE1,VEN1,VES1,VGG2,VX,VXU,VXU1,VX2
	87528-733-E90	MARK, CHOKE (H=36)	1	-	-	-----	HX4,LD4,LHQ4,LX4,QG,QHQ4,QXB2,QXE4,QX4,QX7,RG,RHQ4,RX4,SD4,SHQ4,SMC4,SM14,SM24,SXE4,SX4,SX7,TX4,VNG4,VSD,VSD7,VX4
	87528-ZE1-690	MARK, CHOKE (THAI)	1	-	-	-----	QT
	87528-ZH8-S00	MARK, CHOKE	-	-	1		
	87528-777-000	1	-	-	1511153	VMG1
9	87528-883-661	MARK, CHOKE	-	1	-		
10	87532-ZB4-660	MARK, OIL ALERT (GERMAN)	1	1	-	-----	HX,HXQ,HXU,HX2,LX,NX,PX,PXU,PX2,QX,QXC,QXE,QXE2,QXF,QXF2,QXQ,QXS2,QXU,QX2,QX26,RX,RXU,SX,SXU,TX,TEX,TXU,TXU1,TX2,UX,VA2,VX,VXP,VXU,VXU1,VX2
			1	-	-	1144320	LX2
	87532-ZB4-H50	MARK, OIL ALERT (FRENCH)	1	1	-	-----	HX,HXQ,HXU,HX2,HX26,LX,NX,PX,PXU,PX2,QX,QXC,QXE,QXE2,QXE6,QXF,QXF2,QXQ,QXS2,QXU,QX2,QX26,RX,RXU,SX,SXU,TX,TEX,TXU,TXU1,TX2,UX,VA2,VX,VXP,VXU,VXU1,VX2
			1	-	-	1144320	LX2
	87532-ZH8-000	MARK, OIL ALERT (INTERNAL) ..	1	-	-	-----	LJC1,LSJ,SM21,VEE1,VEN1,VES1
	87532-ZH8-810	MARK, OIL ALERT (EXTERNAL) ..	1	1	-	-----	HX,HXQ,HXU,HX2,HX26,LX,LX2,NX,PMX,PX,PXU,PX2,QG2,QTP2,QX,QXC,QXC9,QXE,QXE2,QXE6,QXE8,QXF,QXF2,QXQ,QXS2,QXU,QX2,QX26,RX,RXU,RX2,SM12,SM22,SX,SXU,TX,TEX,TXU,TXU1,TX2,UX,VA2,VGG2,VX,VXP,VXU,VXU1,VX2
11	87532-ZH8-W40	MARK, THROTTLE INDICATION ...	1	-	-	-----	HX4,LD4,LHQ4,LX4,QG,QHQ4,QH4,QSW4,QXB2,QXE4,QXH4,QX4,QX7,RG,RHQ4,RX4,SD4,SHQ4,SMC4,SM14,SM24,SWG4,SXE4,SX4,SX7,TX4,VX4
12	87534-ZE1-841	LABEL, AIR CLEANER CAUTION ..	1	-	-	-----	QTP2,QXC,QXC9
13	87535-ZE1-840	MARK, AIR CLEANER SALES POINT	1	-	-	1829719	QH4,QTP2,QXC,QXC9,QXH4
	87535-ZE1-841	1	-	-	1829720	QH4,QTP2,QXC,QXC9,QXH4
14	87528-ZB2-000	MARK, CHOKE	1	-	-	-----	VEN,VES
	87528-ZB2-630	1	-	-	-----	VAA1,VEN4,VMT,VSD1,VSD2,VS17
15	87533-ZC0-630	MARK, AIR CLEANER	1	-	-	-----	VAA1,VEN4,VMT
16	87565-ZB4-A00	PLATE, FUEL INDICATION	1	-	-	-----	VAA,VAA1,VMT
17	87539-898-620	MARK, EX. CAUTION (ENGLISH/FRENCH)	1	-	-	-----	VMT
19	87522-ZH9-000	LABEL, CAUTION	1	-	-	1660606	LVL,QVL



E-28

LABEL

K 1

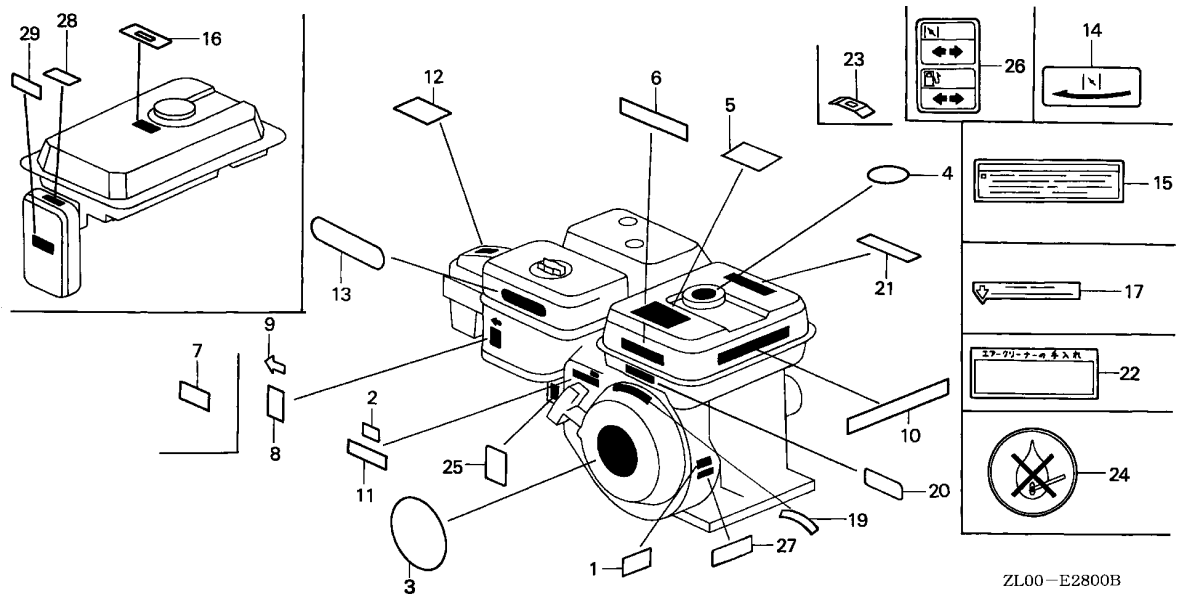

ZL00-E2800B

Ref. No.	Part No.	Description	Reqd. QTY			Serial No.	Parts catalogue code
			(1)	(2)	(3)		
19)	87522-ZH9-010	LABEL, CAUTION	1	-	-	NTU,QXB2,VSD2	
	20	87135-ZE2-000 LABEL, E-SPEC (HONDA) (EPA STANDARD)	1	-	-	1660607	LVL,QVL
		87135-ZE2-010 LABEL, E-SPEC (EPA STANDARD)	-	1	-	1000127	VXP
			1	-	-	1000128	QXE8,QX7,SWG4,SX7,VEN1,VSD7,VS17
			-	1	-		VXP
21	87526-ZH8-000	MARK B, COMBINATION	1	-	-		LJC1,LSJ,NAX,NAX1,NJC1,NMB,NTB,QJF,QJF1,SM11,SM21,VEE1,VEN1,VES1
			1	-	-	1012988	VMG1
			1	-	-	1044773	LJ,LJG,NJ,NJG,SJ,SJG
			1	-	-		VEN
22	87533-ZA7-000	MARK, AIR CLEANER	1	-	-		VEN,VES
23	87565-ZE2-000	MARK, FUEL (INTERNAL)	1	-	-		LJG,NAX,NAX1,NJG,NMB,NTB,QJF,SJG,VEE1,VEN1
	87565-ZE2-810	MARK, FUEL (EXTERNAL)	1	-	-		QTP2
24	87522-ZE1-810	MARK, CAUTION	1	-	-	1289073	SMG1
25	87535-ZH8-V00	MARK, CARBURETOR DRAIN	1	-	-		SMG1,SMG2
26	87528-777-000	MARK, CHOKE	1	-	-		SM11
			1	-	-	1511152	VMG1
27	87532-ZH8-000	MARK, OIL ALERT (INTERNAL) ..	1	-	-	1289073	SMG1
	87532-ZH8-810	MARK, OIL ALERT (EXTERNAL) ..	1	-	-		VSD2
28	87528-ZB2-630	MARK, CHOKE	1	-	-		VAA,VSD2,VS17
29	87533-ZC0-630	MARK, AIR CLEANER	1	-	-		VAA

2

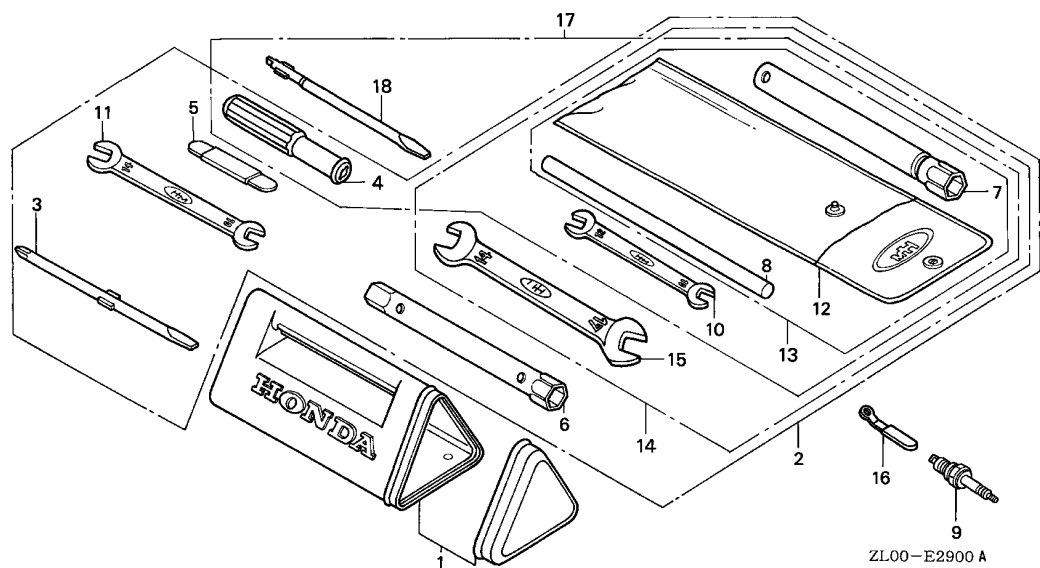

Ref. L.O.N. (Relative ref. Number) F.R.T.
No. Description

NO INFORMATION

Ref. No.	Part No.	Description	Reqd. QTY			Serial No.	Parts catalogue code
			(1)	(2)	(3)		
1	83501-ZF1-000	BOX, TOOL	1	-	-	-	LDB2,LHB2,QAB2,QM,QT,SDB2
2	89001-ZF1-000	BAG SET, TOOL	1	-	-	-	LDB2,LHB2,QAB2,QM,QT,SDB2
3	89102-538-000	SHAFT, SCREW DRIVER	1	-	-	-	LDB2,LHB2,QAB2,QM,QT,SDB2
4	89103-538-000	GRIP	1	-	-	-	LDB2,LHB2,QAB2,QM,QT,SDB2
	99003-50000	GRIP, SCREW DRIVER	1	-	-	-	LVL,QVL
5	89210-ZF1-000	GAUGE ASSY., THICKNESS	1	-	-	-	LDB2,LHB2,QAB2,QM,QT,SDB2
6	89216-ZF1-000	WRENCH, BOX	1	-	-	-	LDB2,LHB2,QAB2,QM,QT,SDB2
	89216-ZH8-S00	WRENCH, PLUG	-	-	1	-	-
7	89216-ZB4-000	WRENCH, PLUG	1	-	-	-	QJF1
	89218-ZE1-000	WRENCH COMP., SPARK PLUG	1	-	-	-	LDB2,LDN,LHB2,LHP1,LJ,LJC1,LJG,LSJ,NAX,NAX1,NDF1,NDJ,NJ,NJG,NMB NTB,NTU,NW,NWA,NWB2,PMX,QAB2,QHP1,QJF,QM,QT,QTP,QTP2,QXC9,SDB2 SDN,SJ,SJG,SMC4,SMG1,SMG2,SM11,SM12,SM14,SM21,SM22,SM24,SWG4,VEE1 VES1,VMG1,VNG4
			1	-	-	1106038	VEN
			(1)	-	-	-	BL,QA,QA2,QXC
	99004-21001	WRENCH, BOX (P21)	1	-	-	-	VEN4,VES,VMT
			1	-	-	1106039	VEN
	89216-357-000	1	-	-	-	NJC1
	99004-21003	1	-	-	-	LVL,QVL
8	89219-805-000	HANDLE, BOX WRENCH	1	-	-	-	LDB2,LDN,LHB2,LHP1,NWB2,PMX,QAB2,QHP1,QM,QT,QTP,SDB2,SDN,SMG1 SMG2,SM11,SM12,SM14,SM21,SM22,SM24,SWG4,VMG1
			1	-	-	1383993	BL
			1	-	-	1106038	VEN
			-	-	1	-	-
	99005-01000	BAR A, HANDLE	1	-	-	-	LVL,NJC1,QVL
9	98079-56846	PLUG, SPARK (BPR6ES) (NGK) ...	1	-	-	1122111	LHB2,QAB2
	98079-56854	PLUG, SPARK (W20EP-U) (DENSO)	1	-	-	-	LDN,NTU,QM,SDN



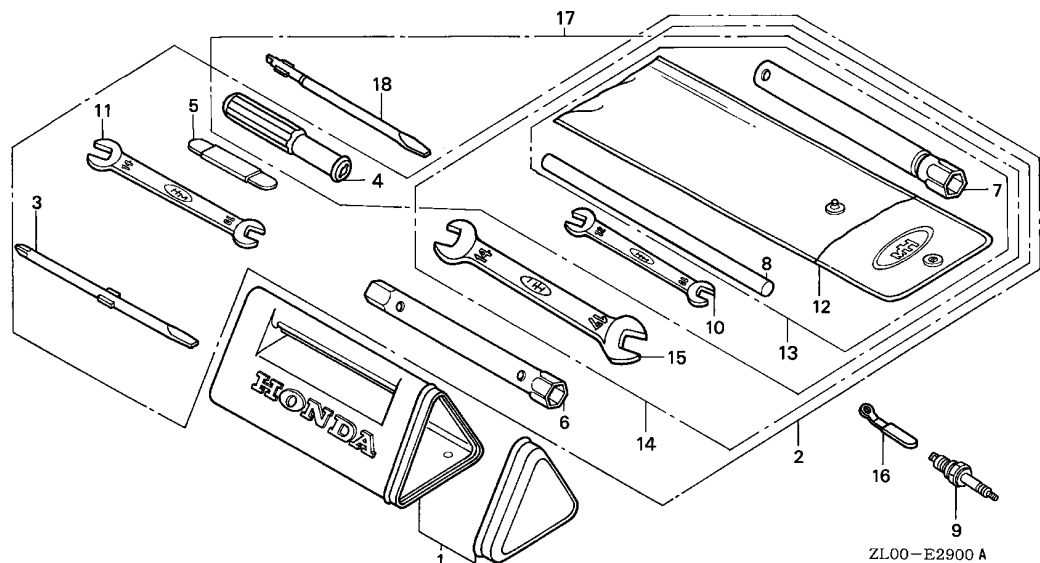

Ref. No.	Part No.	Description	Reqd. QTY			Serial No.	Parts catalogue code
			(1)	(2)	(3)		
(9)	98079-56841	PLUG, SPARK (BP6ES) (NGK)	1	-	-	-----	LDB2,LDN,LVL,NWB2,QM,QVL,SDB2,SDN
			1	-	-	1383993	BL
10	99001-10120	SPANNER, 10X12	1	-	-	1122110	LHB2,QAB2
			1	-	-	-----	LDB2,LHB2,LHP1,LVL,PMX,QAB2,QHP1,QM,QT,QTP,QVL,SDB2,SWG4
			1	-	-	1106038	VEN
11	99001-10140	SPANNER, 10X14	1	-	-	-----	LDB2,LHB2,QAB2,QM,QT,SDB2
12	99008-02300	BAG, TOOL, 230MM	1	-	-	-----	LDB2,LDN,LHB2,NWB2,PMX,QAB2,QM,QT,QTP,SDB2,SDN,SWG4
			1	-	-	1383993	BL
			1	-	-	1106038	VEN
	99008-02000	BAG, TOOL, 200MM	1	-	-	-----	LHP1,LVL,QHP1,QVL
13	89000-ZH7-T00	TOOL KIT	1	-	-	-----	LDN,NWB2,SDN
			1	-	-	1383993	BL
			1	-	-	-----	LHP1,PMX,QHP1,QTP,SWG4
14	89000-ZE1-000	TOOL KIT	1	-	-	-----	1106038
	89000-ZL0-V30	TOOL KIT (###)	1	-	-	-----	VEN
15	99001-14170	SPANNER, 14X17	1	-	-	-----	LHP1,PMX,QHP1,QTP,SWG4
			1	-	-	1106038	VEN
16	32901-MA1-000	CLIP, SUB CORD	3	-	-	-----	SM24
17	89000-ZB6-000	TOOL KIT	1	-	-	-----	LVL,QVL
18	99003-30000	DRIVER MINUS SCREW 3,(NO.2) ..	1	-	-	-----	LVL,QVL

ZL00-E2900 A

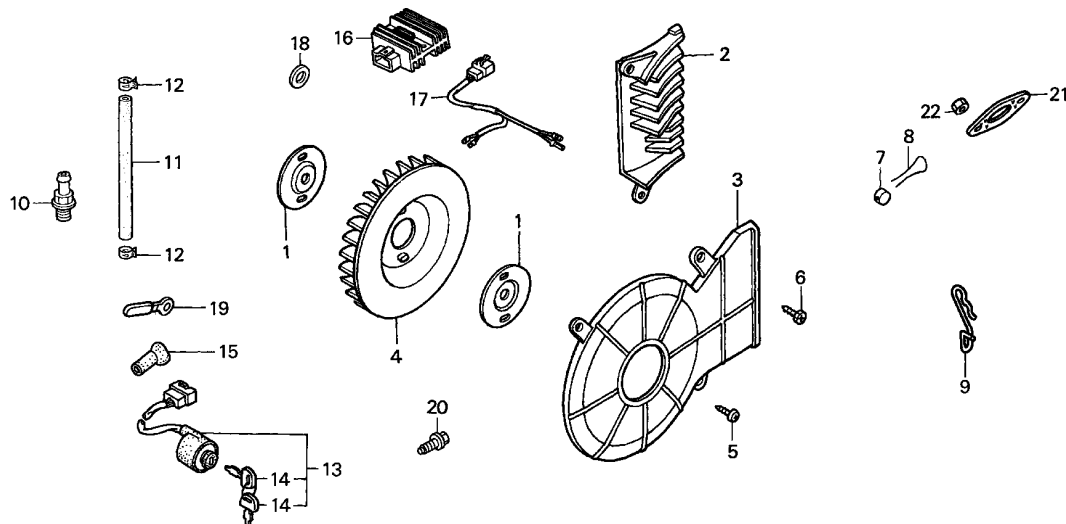

ZL00-E4000 B

Ref. (Relative ref. Number)
No. L.O.N. Description F.R.T.

NO INFORMATION

Ref. No.	Part No.	Description	Reqd. QTY			Serial No.	Parts catalogue code
			(1)	GX200 (2)	(3)		
1	19512-ZA8-000	PLATE, FAN SETTING	2	-	-	1269858	VEE1
2	31107-ZC0-003	GUIDE, GENERATOR AIR	1	-	-	1269858	VEE1
3	31109-ZC0-003	COVER, GENERATOR FAN	1	-	-	1269858	VEE1
4	31112-ZC0-003	FAN, COOLING	1	-	-	1269858	VEE1
5	90031-ZA1-003	SCREW, TAPPING, 5X14	1	-	-	1269858	VEE1
6	90031-ZC0-003	SCREW, TAPPING, 5X18	2	-	-	1269858	VEE1
7	16727-705-000	END, LOCK	1	-	1113370	-----	VEE1
8	16729-705-010	WIRE, LOCK	1	-	1113370	-----	VEE1
9	32901-MA1-000	CLIP, SUB CORD	3	-	-	-----	SM21
10	15550-ZK8-P90	JOINT, DRAIN	2	-	-	-----	SM11,SM12,SM14
11	15552-ZB9-000	TUBE, DRAIN	1	-	-	-----	SM11,SM12,SM14
12	95002-41200-08	CLAMP, TUBE (D12)	2	-	-	-----	SM11,SM12,SM14
13	35100-752-023	SWITCH ASSY., COMBINATION ...	1	-	-	-----	NJC1
14	35110-VA3-903	KEY ASSY., COMBINATION SWITCH	2	-	-	-----	NJC1
15	32411-253-000	COVER, STARTER MOTOR TERMINAL	1	-	-	-----	NJC1
16	31600-ZE2-861	RECTIFIER ASSY., REGULATOR (10A)	1	-	-	-----	QSW4,QXH4
			1	-	1607319	-----	QH4
17	32110-ZB5-G30	HARNESS ASSY., SUB WIRE	1	-	-	-----	QSW4,QXH4
			1	-	1607319	-----	QH4
18	90601-ZE1-000	WASHER, DRAIN PLUG, 10.2MM ..	1	-	-	-----	QJF1
			3	-	-	-----	SM12,SM14
19	32901-MA1-000	CLIP, SUB CORD	3	-	-	-----	SM22
20	90013-883-000	BOLT, FLANGE, 6X12(CT200) ...	2	-	-	-----	QJF1
21	18381-ZH8-800	GASKET, MUFFLER	1	-	-	-----	SWG4
22	94001-08000-0S	NUT, HEX., 8MM	2	-	-	-----	SWG4



EOP-1

GASKET KIT

K 5

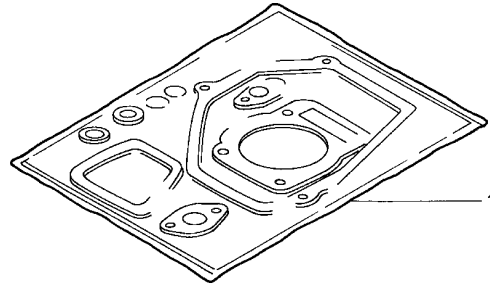

HENG-X0003

Ref. L.O.N. (Relative ref. Number) F.R.T.
No. Description

NO INFORMATION

Ref. No.	Part No.	Description	Reqd. QTY			Serial No.	Parts catalogue code
			(1)	GX200 (2)	(3)		
1	06111-ZL0-000	GASKET KIT	1	-	-	-----	BL, HX, HXQ, HXU, HX2, HX26, HX4, LD, LDB1, LDB2, LD4, LH, LHB2, LHP1, LHQ4, LJ, LJC1, LJG, LSJ, LVL, LX, LX2, LX4, NAX, NAX1, NDF1, NDJ, NJ, NJC1, NJG, NMB, NTB, NTU, NW, NWA, NWB2, NX, PMX, PX, PXU, PX2, QA, QAB2, QA2, QD, QG, QG2, QH, QHP1, QHQ4, QH26, QH4, QJF, QJF1, QM, QSW4, QT, QTP, QTP2, QVL, QX, QXB2, QXC, QXC9, QXE, QXE2, QXE4, QXE6, QXE8, QXF, QXF2, QXH4, QXQ, QXS2, QXU, QX2, QX26, QX4, QX7, RG, RH, RHA2, RHQ4, RH2, RH26, RMG2, RX, RXU, RX2, RX4, SD, SDB1, SDB2, SD4, SH, SHQ4, SJ, SJG, SMC4, SMG1, SMG2, SM11, SM12, SM14, SM21, SM22, SM24, SWG4, SX, SXE4, SXU, SX4, SX7, TX, TXE, TXU, TXU1, TX2, TX4, UX, VAA, VAA1, VA2, VEE1, VEN, VEN1, VEN4, VES, VES1, VGG2, VMG1, VMT, VNG4, VSD, VSD1, VSD2, VSD7, VS17, VX, VXU, VXU1, VX2, VX4
			-	1	1		

2

PART NO. INDEX

L 2

Part Number	Address	Page	Ref.	Part Number	Address	Page	Ref.	Part Number	Address	Page	Ref.	Part Number	Address	Page	Ref.	Part Number	Address	Page	Ref.
16729-705-010	K4	133	8	17401-ZE1-810	H5	86	4	18310-ZL0-W80	H12	93	1	19630-ZH8-000	F14	63	6	28405-ZL0-000ZA	F6	55	2
16851-ZE1-000	I2	99	24	17402-ZE1-810	H5	86	5	18315-ZE1-000	H7	88	3	19640-ZL0-V30	F14	63	6	28405-ZL0-000ZB	F6	55	2
16852-ZB6-000	I5	102	1	17403-ZE1-810	H5	86	6	18320-ZB2-000	H11	92	7					28405-ZL0-000ZD	F6	55	2
16852-ZE1-000	I2	99	25	17404-841-000	H5	86	7	18320-ZF1-H51	H8	89	4	21000				28410-ZE1-003ZA	F11	60	2
16854-ZH8-000	H14	95	3	17410-ZE1-020	G16	81	9	18320-ZL0-V30	H11	92	7					28410-ZE1-003ZF	F11	60	2
16854-ZH8-810	I2	99	26					18325-ZB2-000	H11	92	8	21121-ZL0-W80	J14	127	1	28410-ZH8-003YA	F6	55	3
16857-ZB6-000	I5	102	2					18325-ZH8-T90	H11	92	8	21510-883-621	J11	124	1	28410-ZH8-003ZA	F6	55	3
16910-GB2-005	I5	102	3	17410-ZE1-840	H4	85	9	18325-ZL0-V30	H11	92	8	21512-ZL0-W80	J14	127	2	28410-ZH8-003ZB	F6	55	3
16915-GB2-000	I5	102	4	17421-ZE1-000	H3	84	7	18329-ZB2-000	H11	92	9	21521-883-741	J13	126	1	28410-ZH8-003ZX	F6	55	3
16950-898-632	H14	95	4					18330-ZB2-000	H11	92	2	21591-ZH8-620	J11	124	2	28410-ZH8-003ZY	F6	55	3
	I3	100	3	17470-ZE1-841	H4	85	10	18330-ZB6-000	H13	94	2	21591-ZH8-740	J13	126	2	28410-ZH8-D51	F6	55	3
16950-898-633	H14	95	4	17470-ZE1-842	H4	85	10	18331-883-810	H8	89	5	21610-822-611	J11	124	3	28414-ZK8-V70	F10	59	16
	I3	100	3	17475-ZE1-841	H4	85	11	18338-ZB3-E30	H11	92	11	21621-883-741	J13	126	3	28414-ZK8-V71	F10	59	16
16952-883-005	H14	95	5	17476-ZE1-841	H4	85	12	18355-898-630	H11	92	3	21691-ZH8-800	J11	124	4	28420-ZE1-003	F11	60	3
	I3	100	4	17478-ZE1-841	H4	85	13					21692-ZH8-800	J13	126	4	28420-ZH8-013	F7	56	4
16952-952-003	I2	99	27	17500-ZE1-813ZA	H14	95	7	18355-ZL0-000	H8	89	6	22000				28422-ZE1-003	F11	60	4
16952-GG2-731	H14	95	5	17500-ZE1-813ZC	H15	96	7	18361-ZL0-000	H8	89	7					28422-ZH8-013	F7	56	5
	I3	100	4	17500-ZE1-813ZF	H15	96	7	18381-ZE1-800	H11	92	4	22010-ZL0-W80	J14	127	17	28423-ZE1-003	F11	60	5
16952-ZB6-000	I5	102	5	17505-898-023	I5	102	6					22121-883-620	J11	124	5	28431-ZE1-003	F11	60	6
16953-ZE1-811	G8	73	19	17505-ZB2-003	I3	100	5	18381-ZH8-800	H8	89	8	22201-822-610	J11	124	6	28433-ZH8-003	F8	57	6
16953-ZE1-812	G8	73	19	17505-ZE1-013	H15	96	8					22311-822-610	J11	124	7	28441-ZE1-003	F11	60	7
16954-ZE1-811	G8	73	20	17507-ZA0-800	I5	102	7					22311-822-610	J11	124	7	28441-ZH8-003	F8	57	7
16954-ZE1-812	G8	73	20	17510-ZB2-000ZB	I3	100	6					22350-822-610	J11	124	8	28442-ZE1-003	F11	60	8
16954-ZF0-841	G8	73	20	17510-ZB6-010	I5	102	8					22350-ZL0-W81	J14	127	3	28442-ZH8-003	F8	57	8
16955-ZE1-000	H14	95	6	17510-ZE1-020ZA	H15	96	9	18433-ZH8-W40	H8	89	9	22401-ZL0-W81	J14	127	4	28443-ZE1-003	F11	60	9
16956-ZE1-811	G9	74	21	17510-ZE1-020ZB	H15	96	9	18434-ZH8-W40	H8	89	10	22411-822-611	J11	124	9	28443-ZH8-003	F8	57	9
16957-ZE1-812	G9	74	22	17510-ZE1-020ZF	H15	96	9	18436-ZH8-W40	H8	89	11	22421-822-610	J11	124	10	28445-ZE1-003	F11	60	10
16967-ZE0-811	G10	75	23	17510-ZE1-020ZM	H15	96	9	18466-ZH8-W40	H8	89	12	22521-822-610	J11	124	11	28446-ZE1-003	F11	60	11
				17510-ZE1-020ZN	H15	96	9	19000				22531-883-620	J11	124	12	28447-ZE1-003	F11	60	12
17000				17510-ZF1-T00ZA	H15	96	9					22535-822-610	J11	124	13	28448-ZE1-003	F11	60	13
				17520-ZA0-800	I5	102	9	19511-ZE1-000	I6	103	2	22804-148-000	J14	127	5	28450-ZL0-810	I6	103	3
17210-ZE1-822	G15	80	2	17620-899-013	I5	102	10	19512-ZA8-000	K4	133	1	23000				28451-ZE1-003	I6	103	4
	H4	85	2	17620-Z0T-305	H16	97	11	19610-ZL0-000ZA	F12	61	2	23110-ZE1-610	J9	122	4	28451-ZH8-003	I6	103	4
17211-ZB2-000	H6	87	1	17620-Z0T-814	I3	100	7	19610-ZL0-000ZB	F12	61	2	23120-883-620	J11	124	14	28451-ZL0-000	I6	103	4
17211-ZE1-000	H2	83	1	17620-ZE2-W00	H15	96	10	19610-ZL0-000ZD	F12	61	2	23150-ZL0-W81	J14	127	6	28461-ZE1-003	F11	60	14
17212-ZB2-000	H6	87	2	17620-ZE2-W11	H15	96	10	19610-ZL0-000ZE	F12	61	2	23161-822-611	J11	124	15	28461-ZH8-003	F8	57	10
17212-ZE1-000	H2	83	2	17620-ZH7-023	H16	97	11	19610-ZL0-000ZF	F12	61	2	23710-883-740	J13	126	5	28462-ZE1-003	F11	60	15
17218-ZE1-821	G15	80	3					19610-ZL0-000ZG	F12	61	2	23710-ZE1-613	J9	122	5	28462-ZH8-003	F9	58	11
	H4	85	3	17624-187-020	I5	102	11	19610-ZL0-000ZJ	F12	61	2	23711-822-610	J11	124	16	28462-ZH8-R10	F9	58	11
17219-733-010	H4	85	4	17631-329-003	H16	97	13	19610-ZL0-820ZC	F12	61	2	30000							
17220-ZB2-000	H6	87	3	17631-899-000	I5	102	12	19610-ZL0-820ZF	F12	61	2	30500-ZE1-033	I8	105	1				
17222-ZL0-V30	H6	87	4	17631-Z0T-812	H16	97	12	19610-ZL0-830ZA	F16	65	16	30500-ZE1-043	I8	105	1				
17230-ZE1-820	G16	81	4					19610-ZL0-830ZB	F16	65	16	30600-ZE1-013	I8	105	2				
17230-ZE1-841	H4	85	5	17631-ZH7-003	H16	97	12	19610-ZL0-830ZD	F16	65	16	30700-ZB6-013	I8	105	2				
17231-ZB2-000	H6	87	5					19611-ZH8-810	F13	62	3	30700-ZE1-013	I9	106	2				
17231-ZE1-000	H2	83	3	17670-ZB6-000	I5	102	13	19611-ZH8-820	F14	63	3	30700-ZE8-003	I9	106	2				
17232-891-000	G16	81	5	17672-880-000	H16	97	15	19612-ZH8-000	F13	62	3								
	H4	85	6	17672-887-791	H16	97	15	19612-ZH8-810	F13	62	3								
17233-896-701	H7	88	1	17672-ZE2-W01	H16	97	14	19612-ZH8-811	F13	62	3	28000							
17235-ZE1-831	G16	81	6					19612-ZH8-812	F13	62	3								
17238-ZE7-010	G16	81	7	17673-893-000	H16	97	16					28400-ZE1-003ZA	F11	60	1	31000			
	H2	83	4									28400-ZE1-003ZF	F11	60	1	31100-ZE1-010	I6	103	5
	H4	85	7	18000				19612-ZH8-820	F14	63	3	28400-ZH8-013YA	F5	54	1	31100-ZE7-010	I6	103	5
	H5	86	2					19612-ZH8-821	F14	63	3	28400-ZH8-013ZA	F5	54	1	31107-ZC0-003	K4	133	2
17239-733-000	H4	85	8	18310-Z8K-870	H7	88	2	19612-ZH8-830	F14	63	3	28400-ZH8-013ZB	F5	54	1	31109-ZC0-003	K4	133	3
17239-ZE1-000	G16	81	8	18310-ZB3-C00	H11	92	1	19612-ZH8-840	F16	65	17	28400-ZH8-013ZX	F5	54	1	31110-ZL0-810	I6	103	5
	H2	83	5	18310-ZB6-C01	H13	94	1	19613-ZE1-000	F14	63	4	28400-ZH8-013ZY	F5	54	1	31110-ZL0-811	I7	104	5
	H5	86	3	18310-ZL0-000	H7	88	2	19613-ZE1-020	F14	63	4	28400-ZH8-D52	F5	54	1	31110-ZL0-821	I7	104	6
17252-ZB2-000	H6	87	6	18310-ZL0-800	H7	88	2	19620-ZL0-V30	F14	63	5	28400-ZH8-R10ZA	F5	54	1	31110-ZL0-U52	I7	104	6

PART NO. INDEX

L 4

Part Number	Address	Page	Ref.	Part Number	Address	Page	Ref.	Part Number	Address	Page	Ref.	Part Number	Address	Page	Ref.
91000				94000				95701-06012-00				99101-ZH7-0680			
91001-GF6-004	E8	41	8	94001-04390-0S	J8	121	21	E6	39	16		G10	75	26	
91001-ZF1-003	E6	39	10	94001-08000-0S	H10	91	20	E11	44	8		G10	75	26	
91001-ZF1-004	E6	39	10		H11	92	6	H10	91	22		G10	75	26	
91008-ZL0-W81	J14	127	14		H12	93	3	H11	92	13		G11	76	26	
91201-Z0T-801	E6	39	11		H13	94	7	95701-06016-00	J5	118	11	G11	76	26	
	E9	42	9		K4	133	22	95701-06018-00	F10	59	13	G11	76	26	
	E11	44	6	94050-06000	H1	82	11		H6	87	9	G11	76	26	
	J10	123	11		H3	84	9	95701-06020-00	H1	82	12	G11	76	26	
91202-805-610	J11	124	22		H4	85	16		H3	84	10	G12	77	26	
91202-883-005	E6	39	11		H4	85	16		H4	85	17	G12	77	26	
	E9	42	9		H5	86	11	95701-06025-00	H5	86	12	G14	79	18	
	E11	44	6		H5	86	11		J5	118	12	G12	77	26	
	J10	123	11		H11	92	12	95701-06055-00	J12	125	29	G14	79	18	
	J13	126	8		I1	98	20	95701-08022-00	J12	125	30	G14	79	18	
91301-805-000	J11	124	23	94050-06080	J4	117	24		J14	127	15	99101-ZH8-0780	G14	79	18
91301-ZE1-003	I12	109	29	94050-10000	J5	118	9	95701-08030-00	E10	43	11	99104-ZL0-0350	G13	78	11
91353-671-004	E6	39	12	94101-04800	J8	121	27	95701-08032-00	E10	43	11	99204-ZA0-0450	G12	77	27
	H16	97	18	94101-06800	E6	39	14	95701-08035-00	E11	44	9	99204-ZE2-0400	G14	79	19
91356-706-000	I5	102	14	94103-05700	H10	91	21		J13	126	10				
91402-ZE6-003	I12	109	30	94109-12000	J12	125	26	95723-08060-00	J13	126	10				
91403-ZE6-003	I12	109	31		J13	126	9		J13	126	11				
91406-671-000	F10	59	15	94111-04800	J8	121	28		J14	127	16				
	F16	65	27	94111-08000	J12	125	27	96000	E2	35	14				
91406-ZE2-003	J8	121	18	94251-08000	E6	39	15	96100-62040-00	J13	126	12				
91552-898-000	I3	100	13	94301-08100	I12	109	34	96100-62050-00	E10	43	12				
					J12	125	28		E11	44	10				
92000				94301-08140											
92101-08020-0A	H11	92	5		E10	43	10		J10	123	14				
	H13	94	6	94301-10160	E11	44	7	96100-62060-00	J12	125	31				
92101-08025-0A	E13	46	10	94305-20062	J10	123	13	96100-63050-00	J12	125	32				
	J10	123	12	94305-20122	E2	35	12		J13	126	13				
92101-08035-0A	J11	124	24		G10	75	25	98000							
92800-12000	J12	125	25		G13	78	10								
					G14	79	17	98079-55846	E2	35	15				
93000				95000											
93500-03006-1H	G10	75	24	95001-45140-40	I1	98	21	98079-55855	E2	35	15				
93500-03008-1G	G10	75	24	95001-45155-40	I1	98	21	98079-56841	E3	36	15				
93500-03012-0H	J8	121	19	95001-45250-40	I4	101	16		K3	132	9				
93500-04006-0H	J3	116	21	95001-45300-40	I1	98	21	98079-56846	E3	36	15				
	J4	117	33		I5	102	15		K2	131	9				
93500-04008-0A	G12	77	35	95001-45380-40	I5	102	15	98079-56855	E4	37	15				
93500-04012-0H	J8	121	20	95001-45430-40	I1	98	21	98200-30500	J8	121	23				
93500-05008-0A	G12	77	36	95002-02080	I2	99	22	98200-31500	J8	121	23				
	J5	118	8		I4	101	17	99000							
93500-05016-0A	J3	116	22		I5	102	16	99001-10120	K3	132	10				
93500-05025-0A	J3	116	23	95002-02100	I2	99	28	99001-10140	K3	132	11				
93500-05025-0H	J4	117	23		I5	102	17	99001-14170	K3	132	15				
93500-05035-0A	F16	65	14	95002-41200-08	K4	133	12	99003-30000	K3	132	18				
	J4	117	30	95002-80000	E2	35	13	99003-50000	K2	131	4				
93600-05010-0A	H16	97	19	95701-06008-00	F9	58	13	99004-21001	K2	131	7				
	I3	100	14		F16	65	15	99004-21003	K2	131	7				
93891-06020-07	H10	91	19					99005-01000	K2	131	8				
93892-05014-08	I12	109	32					99008-02000	K3	132	12				
93892-05020-08	I12	109	33	95701-06010-00	H6	87	9	99008-02300	K3	132	12				
					J8	121	22								

PART NAME INDEX

M 1

Part name	Address	Page	Ref.	Part name	Address	Page	Ref.	Part name	Address	Page	Ref.
[A]											
ALERT UNIT, OIL	F16	65	19	BOLT, FLANGE, 6X20	H5	86	12	CAP, CLEANER	H5	86	9
	J8	121	26	BOLT, FLANGE, 6X25	I10	107	9	CAP, FUEL METER	I5	102	7
ARM COMP., GOVERNOR	I14	111	2		I12	109	25	CAP, MUFFLER	H8	89	5
ARM, GOVERNOR	I14	111	3	BOLT, FLANGE, 6X28	J5	118	12	CAP, PRE AIR CLEANER	H4	85	11
ARM, VALVE ROCKER	F2	51	6		I9	106	7	CAP, REDUCTION OIL	J11	124	17
ARRESTER, SPARK	H8	89	6	BOLT, FLANGE, 6X32	J9	122	6	CARBURETOR ASSY.	G4	69	10
	H11	92	3	BOLT, FLANGE, 6X34	I12	109	22		G5	70	10
	H13	94	3	BOLT, FLANGE, 6X35	I2	99	23		G13	78	2
				BOLT, FLANGE, 6X55	J12	125	29		G14	79	9
				BOLT, FLANGE, 6X8	F9	58	13	CASE B, STARTER	F10	59	16
					F16	65	15	CASE COMP., AIR CLEANER	H6	87	3
							21	CASE COMP., RECOIL STARTER	F6	55	3
							28		F11	60	2
				BOLT, FLANGE, 8X22	J12	125	30	CASE, CLUTCH	J14	127	2
BAG SET, TOOL	K2	131	2		J14	127	15	CASE, CONTROL	J7	120	2
BAG, TOOL, 200MM	K3	132	12	BOLT, FLANGE, 8X30	E10	43	11	CASE, PRE AIR CLEANER	H4	85	10
BAG, TOOL, 230MM	K3	132	12	BOLT, FLANGE, 8X32	E10	43	11	CASE, RECOIL STARTER SPRING	F11	60	10
BAND	J7	120	8		E11	44	9	CASE, REDUCTION	J11	124	1
BARREL ASSY., CYLINDER	E5	38	1	BOLT, FLANGE, 8X35	J13	126	10		J13	126	1
BAR A, HANDLE	K2	131	8		J13	126	11	CENTER, CLUTCH	J11	124	5
BASE COMP., CONTROL	J1	114	13		J14	127	7	CENTER, CLUTCH WEIGHT	J11	124	13
	J2	115	13	BOLT, FLANGE, 8X60	E2	35	14	CHAIN, DRIVE	J11	124	15
BASE COMP., MUFFLER COVER	H8	89	11	BOLT, GOVERNOR ARM	J2	115	18	CHAIN, P.T.O. DRIVE	F2	51	5
BEARING, RADIAL BALL	E6	39	10	BOLT, HEX., 5/16"	E13	46	10		J9	122	3
BEARING, RADIAL BALL, 6005	J14	127	14	BOLT, HEX., 8X20	H11	92	5	CHAMBER SET, FLOAT	G2	67	4
BEARING, RADIAL BALL, 6204	J13	126	12		H13	94	6		G14	79	4
BEARING, RADIAL BALL, 6205	E10	43	12	BOLT, HEX., 8X25	E13	46	10	CHOKE KIT, REMOTE CONTROL	G12	77	28
	E11	44	10		J10	123	12	CHOKE SET	G4	69	9
	J10	123	14	BOLT, HEX., 8X35	J11	124	24		G13	78	1
	J12	125	31	BOLT, MUDGUARD	H4	85	14	CIRCLIP, 10.2MM	G14	79	8
BEARING, RADIAL BALL, 6206	J12	125	32	BOLT, PIVOT, 8MM	F4	53	17	CIRCLIP, 5MM	G12	77	34
BEARING, RADIAL BALL, 6304	E8	41	8	BOLT, SETTING	I12	109	21		J3	116	20
BEARING, RADIAL BALL, 6305	J13	126	13	BOLT, STUD, 6X112	E2	35	10		J4	117	32
BODY, CLEANER	H5	86	4	BOLT, STUD, 6X94	E2	35	10	CIRCLIP, 7MM	J14	127	12
BOLT, BREATHING	J13	126	6	BOLT, STUD, 8X32	E2	35	11	CIRCLIP, INTERNAL, 47	J14	127	11
BOLT, CONNECTING ROD	E16	49	5	BOLT, WINKER SETTING	H6	87	7	CLAMPER, CORD	F14	63	4
BOLT, DRAIN PLUG	E6	39	6	BOX ASSY., CONTROL	J6	119	1		I9	106	4
BOLT, DRAIN PLUG, 12MM	J12	125	25		J7	120	1	CLAMP, CORD	F14	63	4
BOLT, DRAIN PLUG, 12X15	J13	126	7	BOX, TOOL	K2	131	1	CLAMP, TUBE	K4	133	12
BOLT, FLANGE, 5X10	I10	107	8	BRACKET COMP., FR.	I12	109	16	CLIP, CORD	F16	65	22
BOLT, FLANGE, 6X10	F9	58	13	BRACKET, CASE MOUNTING	J7	120	3		J8	121	16
	F11	60	16	BUSH, FUEL PURGE	I5	102	5	CLIP, GOVERNOR HOLDER	E6	39	9
	H6	87	9					CLIP, HARNESS	F16	65	13
	J8	121	22					CLIP, PISTON PIN, 18MM	E16	49	6
BOLT, FLANGE, 6X12	E2	35	9					CLIP, PURSE LOCK	F16	65	26
	E6	39	16						J8	121	15
	E11	44	8					CLIP, SUB CORD	F10	59	14
	F15	64	10						K3	132	16
	H10	91	22	CABLE, DOUBLE CONNECTOR	F16	65	25		K4	133	9
	H11	92	13	CAMSHAFT ASSY.	F2	51	2				19
	J2	115	17	CAP ASSY., NOISE SUPPRESSOR	I8	105	2				19
	K4	133	20		I9	106	2				19
BOLT, FLANGE, 6X13	H9	90	13	CAP ASSY., OIL FILLER	E8	41	5	CLIP, TUBE	E2	35	13
BOLT, FLANGE, 6X16	J5	118	11						I2	99	22
BOLT, FLANGE, 6X18	F10	59	13								28
	H6	87	9	CAP COMP., FUEL FILLER	E11	44	3		I4	101	17
BOLT, FLANGE, 6X20	F16	65	11		H15	96	10		I5	102	16
	H1	82	12		H16	97	11				17
	H3	84	10		I3	100	7	CLIP, VALVE GUIDE	E1	34	4
	H4	85	17	CAP, CLEANER	H3	84	7	CLIP, WIRE HARNESS	F10	59	15

PART NAME INDEX

M 2

Part name	Address	Page	Ref.	Part name	Address	Page	Ref.	Part name	Address	Page	Ref.
CLIP, WIRE HARNESS	F16	65	27	CRANKSHAFT COMP.	E12	45	6	GASKET, MUFFLER	H11	92	4
CLIP, WIRE HARNESS, 25MM	J5	118	7								10
COCK ASSY., FUEL	H14	95	4						H12	93	2
	I3	100	3		E13	46	8		H13	94	4
COIL ASSY., CHARGE	I9	106	3								5
			6								21
	I10	107	11	CUP, FUEL STRAINER	G10	75	23	GAUGE ASSY., FUEL	K4	133	8
			12		H14	95	2	GAUGE ASSY., THICKNESS	H15	96	5
COIL ASSY., IGNITION	I8	105	1		I3	100	2	GAUGE, OIL LEVEL	K2	131	18
COIL ASSY., LAMP	I9	106	3					GEAR ASSY.	J11	124	15
	I10	107	10	[D]				GOVERNOR ASSY.	I12	109	3
COLLAR B, AIR CLEANER	G16	81	8					GRID, AIR CLEANER	E5	38	2
	H2	83	5	DISK, CLUTCH FRICTION	J11	124	6		H2	83	7
	H4	85	8	DOWEL PIN, 10X16	E2	35	12	GRIP	H5	86	4
	H5	86	3	DOWEL PIN, 8X10	I12	109	34	GRIP, SCREW DRIVER	K2	131	4
COLLAR, AIR CLEANER	G16	81	7		J12	125	28	GRIP, STARTER	K2	131	4
	H2	83	4	DOWEL PIN, 8X14	J12	125	28	GROMMET, AIR CLEANER	F8	57	10
	H4	85	7		E10	43	10		G16	81	5
	H5	86	2		E11	44	7	GROMMET, CORD	H4	85	6
COLLAR, AIR CLEANER CASE	H7	88	1	DRIVER 3, MINUS SCREW	J10	123	13	GROMMET, DRAIN HOLE	I9	106	5
COLLAR, CONTROL BOX	I3	100	13		K3	132	18	GROMMET, DRAIN HOLE	F16	65	24
COLLAR, STOPPER	J4	117	36	[E]				GUIDE, EX. VALVE	F16	65	24
CONDENSER UNIT	J5	118	3					GUIDE, GENERATOR AIR	E1	34	2
CONTROL ASSY.	I13	110	1	ELBOW COMP., AIR CLEANER	G16	81	9	GUIDE, IN. VALVE	K4	133	2
	I14	111	1		H2	83	6	GUIDE, IN. VALVE	E1	34	1
	J4	117	29		H4	85	9	GUIDE, PRE AIR CLEANER	E1	34	1
			34		H5	86	8	GUIDE, PRE AIR CLEANER	H4	85	12
			38	ELEMENT, AIR CLEANER	H5	86	8	GUIDE, RATCHET	F8	57	6
CORD, MAGNET SWITCH	I12	109	17		G15	80	2		F11	60	9
CORD, STOP SWITCH	F15	64	9		H2	83	1	[H]			
COVER ASSY., CHAIN CASE	J9	122	1		H4	85	2	HANDLE, BOX WRENCH	K2	131	8
COVER ASSY., CRANKCASE	E7	40	1		H4	85	2	HARNESS ASSY., SUB WIRE	K4	133	17
			2	EMBLEM	H5	86	6	HEAD COMP., CYLINDER	E1	34	3
			3	END, LOCK	H6	87	1	HOLDER, CABLE	E1	34	3
	E11	44	1		J15	128	3	HOLDER, CABLE	G12	77	33
COVER COMP., FAN	F12	61	2	[F]				HOLDER, CABLE	I16	113	11
	F16	65	16					HOLDER, CLUTCH SPRING	J11	124	10
COVER COMP., GEAR	I11	108	5	FAN, COOLING	I6	103	2	HOLDER, CLUTCH WEIGHT	J11	124	12
COVER COMP., HEAD	E1	34	6		K4	133	4	HOLDER, CONTROL CABLE	J11	124	12
	E2	35	6	FILTER COMP., FUEL	I5	102	13	HOLDER, FUEL FILTER	G12	77	29
COVER COMP., MUFFLER	H8	89	9	FILTER, FUEL	H16	97	14	HOLDER, FUEL FILTER	H16	97	16
COVER COMP., MUFFLER RR.	H8	89	10					HOLDER, HARNESS	I12	109	28
COVER, AIR CLEANER	G16	81	4		I3	100	9	HOLDER, WIRE	J2	115	16
	H2	83	3	FILTER, OUTER	G15	80	3		J4	117	31
	H4	85	5		H4	85	3	[I]			
	H6	87	5	FLOAT SET	G2	67	3	INSULATOR, CARBURETOR	G6	71	14
COVER, CLUTCH	J14	127	1		G14	79	3		G13	78	4
COVER, GENERATOR FAN	K4	133	3	FLYWHEEL COMP.	I6	103	5		G14	79	12
COVER, MAGNETIC SWITCH	I12	109	18		I7	104	5	[J]			
COVER, REDUCTION	J11	124	3	FUSE, BLADE	J8	121	23	JET SET, PILOT,	G12	77	27
	J13	126	3						G14	79	19
COVER, SPRING	I12	109	14					JET, MAIN,	G10	75	26
COVER, STARTER MOTOR TERMINAL	I12	109	19	[G]					G11	76	26
	K4	133	15	GASKET KIT	K5	134	1		G12	77	26
CRANKSHAFT COMP.	E12	45	1	GASKET SET	G1	66	1	JET, PILOT,	G14	79	18
			2		G14	79	1	JOINT, DRAIN	G13	78	11
			3	GASKET, CYLINDER HEAD	E1	34	5	JOINT, FUEL TANK	K4	133	10
			4	GASKET, MUFFLER	H8	89	8		H14	95	6
			5								



PART NAME INDEX

M 3

Part name	Address	Page	Ref.	Part name	Address	Page	Ref.	Part name	Address	Page	Ref.
[K]											
KEY ASSY., COMBINATION SWITCH	K4	133	14	MARK, OIL ALERT	K1	130	27	O-RING, 26X2.7	J11	124	23
KEY COMP.	J8	121	10	MARK, THROTTLE INDICATION	J16	129	11	O-RING, 56X2.4	I5	102	14
KEY, 4.78X4.78X38	E13	46	12	MARK, TOP	J16	129	6	[P]			
	J14	127	13	METER ASSY., FUEL	I3	100	5				
KEY, 5MM	J11	124	20	METER COMP., FUEL	I5	102	6	PACKING C, FUEL METER	I5	102	11
KEY, 5X5X33	E13	46	12	MOTOR ASSY., STARTER	I11	108	1	PACKING SET, COCK	H14	95	1
	J10	123	10	MOTOR ONLY	I11	108	10		I3	100	1
KEY, 7X7X33	J11	124	21	MOTOR UNIT, STARTER	I11	108	4	PACKING, AIR CLEANER	G14	79	15
KEY, SPECIAL WOODRUFF, 25X18	I6	103	1	MUFFLER COMP.	H7	88	2	PACKING, AIR CLEANER COVER	H4	85	4
KNOB, RECOIL STARTER	F11	60	14		H11	92	1	PACKING, CARBURETOR	G7	72	17
					H13	94	1		G13	78	7
[L]				[N]							
LABEL, AIR CLEANER CAUTION	J16	129	12	NETTING, WIRE FLANGE	H8	89	7	PACKING, CASE COVER	E8	41	4
LABEL, CAUTION	J16	129	6	NOSE, SILENCER	G16	81	6		E11	44	2
			19	NOZZLE, MAIN	G5	70	12	PACKING, CHAIN CASE COVER	J9	122	2
LABEL, E-SPEC	K1	130	19		G6	71	12	PACKING, ELBOW	G15	80	1
LABEL, SPECIFICATION	K1	130	20	NUT	G14	79	11		H4	85	1
LENS ASSY., PROTECTOR	J15	128	1	NUT-WASHER, 6MM	F11	60	13	PACKING, FUEL COCK	H5	86	1
LEVER COMP., CHOKE	J8	121	12	NUT, FLANGE, 10MM	I12	109	23	PACKING, FUEL FILLER CAP	G9	74	22
	G7	72	18	NUT, FLANGE, 6MM	E6	39	13		H16	97	12
	G12	77	31		H1	82	11		I3	100	8
	G13	78	8		H3	84	9	PACKING, FUEL STRAINER CUP	I5	102	12
	G14	79	16		H4	85	16	PACKING, HEAD COVER	G6	71	13
LEVER, COCK	G8	73	19		H5	86	11	PACKING, INSULATOR	E2	35	7
LEVER, CONTROL	I15	112	8		H6	87	8		G6	71	15
	I16	113	8		H11	92	12		G13	78	5
	J4	117	35		I1	98	20		G14	79	13
LEVER, SOLENOID THROTTLE	J5	118	13		J4	117	24	PACKING, OIL FILLER CAP	E8	41	7
LIFTER, VALVE	F4	53	11		J5	118	9		E11	44	4
					J8	121	21	PACKING, REDUCTION CASE	J11	124	2
[M]				NUT, HEX., 4MM	H10	91	18		J13	126	2
MARK A, COMBINATION	J16	129	6	NUT, HEX., 5MM	H10	91	20	PACKING, REDUCTION COVER	J11	124	4
MARK B, COMBINATION	K1	130	21	NUT, HEX., 8MM	H10	91	20		J13	126	4
MARK, AIR CLEANER	J16	129	15		H11	92	6	PANEL COMP., CONTROL	J7	120	4
	K1	130	22		H12	93	3	PANEL, CONTROL BOX	J8	121	13
			29	NUT, LOCK, 24MM	H13	94	7	PAN, CLEANER OIL	H5	86	5
MARK, AIR CLEANER CAUTION	J16	129	7	NUT, PIVOT ADJUSTING	K4	133	22	PIECE A, STOPPER	I11	108	11
MARK, AIR CLEANER SALES POINT	J16	129	13	NUT, SELF-LOCK, 6MM	J14	127	8	PIECE B, STOPPER	I11	108	12
MARK, CARBURETOR DRAIN	K1	130	25	NUT, SPECIAL, 14MM	F4	53	18	PINION ASSY.	I11	108	6
MARK, CAUTION	J15	128	4	NUT, TOOL BOX SETTING	J2	115	19	PIN, LOCK, 8MM	I11	108	6
	J16	129	5		I7	104	7	PIN, PISTON	E6	39	15
	K1	130	24		G16	81	10	PIN, SPRING, 2X12	E16	49	3
MARK, CHOKE	J16	129	8		H3	84	8		G10	75	25
			9		H4	85	15		G13	78	10
			14		H5	86	10		G14	79	17
				[O]							
MARK, CONTROL BOX	J8	121	13	OIL SEAL	J11	124	22	PIN, SPRING, 2X6	J5	118	10
MARK, EMERGENCY SWITCH			28	OIL SEAL, 25X41X6	E6	39	11	PIN, STARTER RATCHET	F11	60	5
			14		E9	42	9	PIPE COMP., EX.	H11	92	2
MARK, EX. CAUTION	J15	128	2		E11	44	6		H13	94	2
MARK, FIRE DANGER	J16	129	5		J10	123	11	PIPE, EX.	H12	93	1
MARK, FUEL	K1	130	23	O-RING	I11	108	3	PISTON	E16	49	2
MARK, FUEL CAUTION	J16	129	4		I12	109	29	PIVOT, ROCKER ARM	F2	51	7
MARK, OIL ALERT	J16	129	10	O-RING, 14MM	E6	39	12	PLATE COMP., CLUTCH PRESSURE	J11	124	8
					H16	97	18	PLATE COMP., DRIVE	J14	127	3
								PLATE COMP., SIDE	F13	62	3
									F14	63	3
								PLATE, CLUTCH	J11	124	7
								PLATE, FAN SETTING	K4	133	1

4

PART NAME INDEX

M 4

Part name	Address	Page	Ref.	Part name	Address	Page	Ref.	Part name	Address	Page	Ref.
PLATE, FRICTION	F11	60	6	SCREW-WASHER, 5X14	I12	109	32	SHROUD COMP.	F14	63	6
PLATE, FUEL INDICATION	J16	129	16	SCREW-WASHER, 5X20	I12	109	33	SHROUD COMP., LOWER	F14	63	6
PLATE, GUARD	E11	44	5	SCREW-WASHER, 5X30	I12	109	24	SLIDER, GOVERNOR	E6	39	4
PLATE, LEVER SETTING	G8	73	20	SCREW-WASHER, 5X8	I12	109	20	SOLENOID ASSY., AUTO THROTTLE	J5	118	6
PLATE, PRE AIR CLEANER	H4	85	13	SCREW-WASHER, 6X20	H10	91	19	SPACER COMP., CARBURETOR	G6	71	16
PLATE, PUSH ROD GUIDE	F4	53	16	SCREW SET	G4	69	8		G13	78	6
PLATE, SIDE	F13	62	3		G14	79	7	SPACER, 20MM	J9	122	8
	F14	63	3	SCREW SET, DRAIN	G3	68	7	SPACER, CONTROL LEVER	I16	113	12
	F16	65	17		G14	79	6	SPACER, MUFFLER COVER	H8	89	12
PLUG, SPARK	E2	35	15	SCREW SET, PILOT	G2	67	5	SPACER, RECOIL STARTER			
	E3	36	15		G3	68	6	MOUNTING	F6	55	2
	E4	37	15		G14	79	5	SPANNER, 10X12	K3	132	10
	K2	131	9	SCREW, FLAT, 5X10	H16	97	19	SPANNER, 10X14	K3	132	11
	K3	132	9		I3	100	14	SPANNER, 14X17	K3	132	15
PROTECTOR, CIRCUIT	J8	121	11	SCREW, LOCK PAN	J4	117	23	SPRING, CABLE RETURN	J2	115	15
PROTECTOR, MUFFLER	H8	89	4		J4	117	30	SPRING, CHOKE RETURN	J5	118	1
PROTECTOR, MUFFLER INNER	H11	92	8	SCREW, PAN, 3X12	J8	121	19	SPRING, CLUTCH	J14	127	4
PROTECTOR, MUFFLER OUTER	H11	92	7	SCREW, PAN, 3X6	G10	75	24	SPRING, CLUTCH FREE	J11	124	9
PULLEY COMP., STARTER	I6	103	3	SCREW, PAN, 3X8	G10	75	24	SPRING, COCK LEVER	G9	74	21
PULLEY, RECOIL STARTER	F11	60	3	SCREW, PAN, 4X12	J8	121	20	SPRING, CONTROL ADJUSTING	F12	61	1
PULLEY, STARTER	I6	103	4	SCREW, PAN, 4X6	J3	116	21		J2	115	14
[R]					J4	117	33	SPRING, FRICTION	F8	57	7
				SCREW, PAN, 4X8	G12	77	35		F11	60	7
RATCHET, STARTER	F7	56	5	SCREW, PAN, 5X16	J3	116	22	SPRING, GOVERNOR	I14	111	6
	F11	60	4	SCREW, PAN, 5X25	J3	116	23	SPRING, GOVERNOR ARM RETURN	I14	111	5
RECTIFIER ASSY., REGULATOR	J5	118	4		J4	117	23	SPRING, LEVER	I16	113	9
	K4	133	16	SCREW, PAN, 5X35	F16	65	14	SPRING, RECOIL STARTER	F8	57	8
RECTIFIER ASSY., SILICON	I7	104	9		J4	117	30		F11	60	8
	J7	120	5	SCREW, PAN, 5X8	G12	77	36	SPRING, RETURN	F8	57	9
RECTIFIER COMP., REGULATOR	I7	104	8		J5	118	8		G12	77	32
REEL, RECOIL STARTER	F7	56	4	SCREW, RECESSED, 5X25	J4	117	37		I11	108	13
RETAINER, EX. VALVE SPRING	F4	53	14	SCREW, SETTING	F9	58	12	SPRING, THROTTLE RETURN	I15	112	7
RETAINER, IN. VALVE SPRING	F4	53	13	SCREW, SPECIAL, 6X12	J8	121	14	SPRING, THRUST	J9	122	7
			14	SCREW, TAPPING, 4X6	H9	90	17	SPRING, VALVE	F4	53	12
					H10	91	17	SPRING, WEIGHT RETURN	F3	52	8
RING SET, PISTON	E14	47	1					SPROCKET COMP., DRIVE	J11	124	14
	E15	48	1	SCREW, TAPPING, 5X14	K4	133	5	SPROCKET, DRIVE	J9	122	4
ROD ASSY., CONNECTING	E16	49	4	SCREW, TAPPING, 5X18	K4	133	6	STARTER ASSY., RECOIL	F5	54	1
ROD, GOVERNOR	I14	111	4	SCREW, TAPPING, 5X25	H9	90	16		F11	60	1
ROD, PUSH	F2	51	4	SCREW, TAPPING, 5X8	H9	90	14	STAY, AIR CLEANER	H6	87	4
ROPE, RECOIL STARTER	F9	58	11					STAY, CHOKE CONTROL	G12	77	30
	F11	60	15	SCREW, THROTTLE STOP	G5	70	11	STAY, MUFFLER	H7	88	3
	F4	53	15		G13	78	3		H11	92	11
ROTATOR, VALVE	I11	108	9	SEAL, AIR CLEANER	H6	87	6	STRAINER COMP., FUEL	I5	102	3
ROTOR ASSY.	E6	39	17	SEAL, FUEL FILLER NECK	I5	102	9	STRAINER, FUEL	I2	99	27
RUBBER, BOTTOM	J14	127	5	SEAL, MUFFLER PROTECTOR	H11	92	9	STRAP, WIRE HARNESS, 25MM	F16	65	23
RUBBER, CLUTCH DAMPER	I3	100	12	SEAL, VALVE STEM	F1	50	1		J8	121	17
RUBBER, CONTROL BOX	E6	39	17	SEPARATOR, AIR CLEANER	H6	87	2	SUB HARNESS	F14	63	7
RUBBER, FR. BOTTOM	H16	97	17	SHAFT COMP., P.T.O.	J11	124	16		J7	120	7
RUBBER, FUEL	I3	100	15		J14	127	6	SUB HARNESS ASSY.	J5	118	5
	I3	100	15	SHAFT UNIT, GEAR	I11	108	7	SUSPENSION, COUPLER	J7	120	6
RUBBER, SUPPORTER	H14	95	3	SHAFT, GOVERNOR ARM	E6	39	5	SUSPENSION, STRAINER	I5	102	4
	I2	99	26	SHAFT, P.T.O.	J9	122	5	SWITCH ASSY., COMBINATION	J7	120	9
	I5	102	2		J13	126	5		K4	133	13
RUBBER, TANK MOUNTING	I3	100	10	SHAFT, SCREW DRIVER	K2	131	3	SWITCH ASSY., ENGINE STOP	F14	63	8
				SHAFT, SUB	F11	60	12	SWITCH ASSY., OIL LEVEL	E5	38	2
[S]				SHROUD ASSY., UPPER	F14	63	5	SWITCH COMP., STARTING MAGNET	I11	108	2
SCREEN SET	H14	95	5								
	I3	100	4								

PART NAME INDEX

M 5

Part name	Address	Page	Ref.	Part name	Address	Page	Ref.	Part name	Address	Page	Ref.
[T]				WIRE, LOCK	K4	133	8				
TANK ASSY., FUEL	H14	95	7	WRENCH COMP., SPARK PLUG	K2	131	7				
	H15	96	7	WRENCH, BOX	K2	131	6				
TANK COMP., FUEL	H15	96	9								
	I3	100	6	WRENCH, PLUG	K2	131	6				
	I5	102	8				7				
TERMINAL ASSY., HIGH TENSION -	I8	105	2	[Y]							
THROTTLE ASSY., AUTO	J5	118	2	YOKE ASSY.	I11	108	8				
TOOL KIT	K3	132	13								
			14								
			17								
TUBE A, FUEL	I2	99	24								
TUBE B, FUEL	I2	99	25								
TUBE, BREATHER	E2	35	8								
TUBE, DRAIN	K4	133	11								
TUBE, FASTENER, 30MM	J8	121	18								
TUBE, FUEL TANK	I5	102	1								
TUBE, FUEL, 4.5X140	I1	98	21								
TUBE, FUEL, 4.5X155	I1	98	21								
TUBE, FUEL, 4.5X250	I4	101	16								
TUBE, FUEL, 4.5X300	I1	98	21								
	I5	102	15								
TUBE, FUEL, 4.5X380	I5	102	15								
TUBE, FUEL, 4.5X430	I1	98	21								
[V]											
VALVE SET, FLOAT	G1	66	2								
	G14	79	2								
VALVE, DASHPOT CHECK	G13	78	9								
VALVE, EX.	F3	52	10								
VALVE, IN.	F3	52	9								
[W]											
WASHER, 8MM	E13	46	11								
	J10	123	9								
	J14	127	10								
WASHER, 9X16X1.4	J14	127	9								
WASHER, AIR DUCT	I3	100	11								
WASHER, CONTROL LEVER	I16	113	10								
WASHER, DRAIN PLUG, 10.2MM ...	E6	39	8								
	K4	133	18								
WASHER, DRAIN PLUG, 12MM	J12	125	26								
	J13	126	9								
WASHER, PINION	I12	109	26								
WASHER, PLAIN, 4MM	J8	121	27								
WASHER, PLAIN, 5MM	H10	91	21								
WASHER, PLAIN, 6MM	E6	39	14								
WASHER, SPECIAL	I12	109	30								
WASHER, SPRING	I12	109	31								
WASHER, SPRING, 4MM	J8	121	28								
WASHER, SPRING, 8MM	J12	125	27								
WASHER, STARTER	F11	60	11								
WASHER, THRUST, 20MM	J11	124	19								
WASHER, THRUST, 6MM	E6	39	7								
WEIGHT SET, CLUTCH	J14	127	17								
WEIGHT, CLUTCH	J11	124	11								

4

1

FOREWORD INDEX

2

ENGINE GROUP

3

PART NUMBER INDEX

4

PART NAME INDEX

HONDA
The Power of Dreams



PARTS CATALOGUE NEWS

Honda Motor Co., Ltd. Service Division

PARTS CATALOGUE - CORRECTED

Printed in Japan

CODE NO.	BOOKLET TYPE	13ZL00E6
	MICRO-FICHE	13ZL00EF/FF
PARTS CATALOGUE NEWS	GX200 GX200[PROPANE ENGINE]	
NEWS NO.	001	

Block No.	Ref. No.	Note	Part No.	Description	Reqd. QTY	Serial No.	Parts catalogue code
					GX200 (1) (2) (3)		

E-17 FUEL TANK (1)

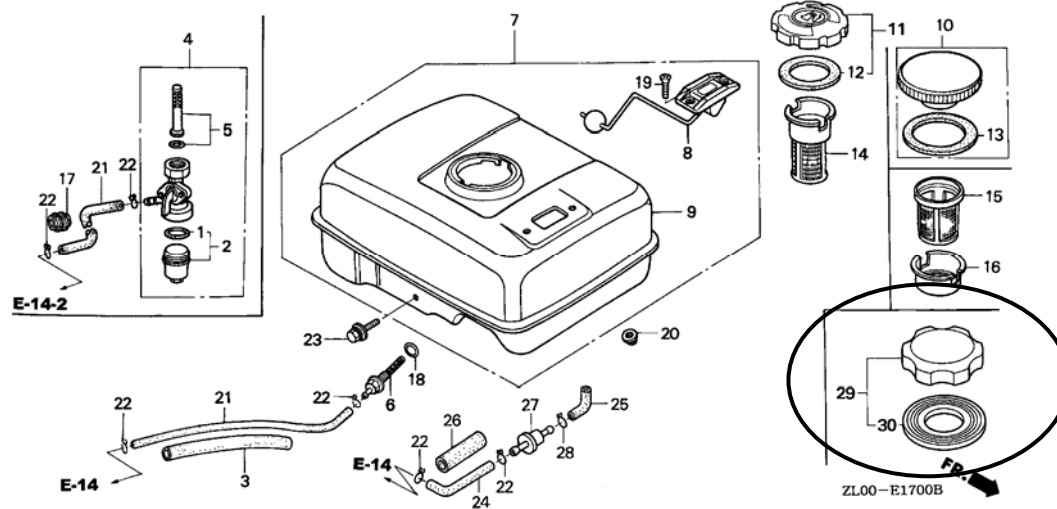

E-17 11 E 17620-Z0T-305 *PARTS NO. DELETION

NOTE A:PART NO. CHANGE D:NEWLY PROVIDED E:PART NO. DELETION K:REQUIRED NO. CORRECTION L:APPLICATION SERIAL NO. CORRECTION
T:APPLICATION CORRECTION Z:REMARKS CHANGE

PARTS CATALOGUE NEWS

BOOKNo. : 13ZL00E6

Block No.	Ref. No.	Note	Part No.	Description	Reqd. QTY			Serial No.	Parts catalogue code
					(1)	(2)	(3)		
	12	E	17631-Z0T-812	*PARTS NO. DELETION					
	29	D	17620-Z0T-305	CAP COMP., FUEL FILLER (CHROME PLATED)	1	-	-	1849431	----- BL, HX, HXU, HX2, HX26, LH, LHB2, LHP1, LHQ4, LJ, LJC1, LJG, LVL, LX2, LX4, NDJ, NJ, NJG, NMB, NTB, NW, NX, PX, PXU, QAB2, QD, QG2, QH, QHP1, QHQ4, QH26, QH4, QJF, QM, QTP, QTP2, QVL, QX, QXB2, QXC9, QXE2, QXE4, QXE6, QXE8, QXH4, QXS2, QXU, QX2, QX26, QX4, QX7, RH, RHQ4, RH2, RH26, RX, RXU, RX2, RX4, SD, SDB2, SH, SHQ4, SJ, SJG, SMC4, SM11, SM12, SM14, SM21, SM22, SM24, SX, SXE4, SXU, SX4, SX7, TX, TXU, TXU1, TX2, VEE1, VEN1, VES1, VMG1, VSD, VSD7, VX, VXU, VXU1, VX2, VX4
	30	D	17631-Z0T-812	PACKING, FUEL FILLER CAP (39X62X3)	1	-	-	1849431	----- BL, HX, HXU, HX2, HX26, LH, LHB2, LHP1, LHQ4, LJ, LJC1, LJG, LVL, LX2, LX4, NDJ, NJ, NJG, NMB, NTB, NW, NX, PX, PXU, QAB2, QD, QG2, QH, QHP1, QHQ4, QH26, QH4, QJF, QM, QTP, QTP2, QVL, QX, QXB2, QXC9, QXE2, QXE4, QXE6, QXE8, QXH4, QXS2, QXU, QX2, QX26, QX4, QX7, RH, RHQ4, RH2, RH26, RX, RXU, RX2, RX4, SD, SDB2, SH, SHQ4, SJ, SJG, SMC4, SM11, SM12, SM14, SM21, SM22, SM24, SX, SXE4, SXU, SX4, SX7, TX, TXU, TXU1, TX2, VEE1, VEN1, VES1, VMG1, VSD, VSD7, VX, VXU, VXU1, VX2, VX4

E-17-1 FUEL TANK (2) (VAA/VAA1/VMT)

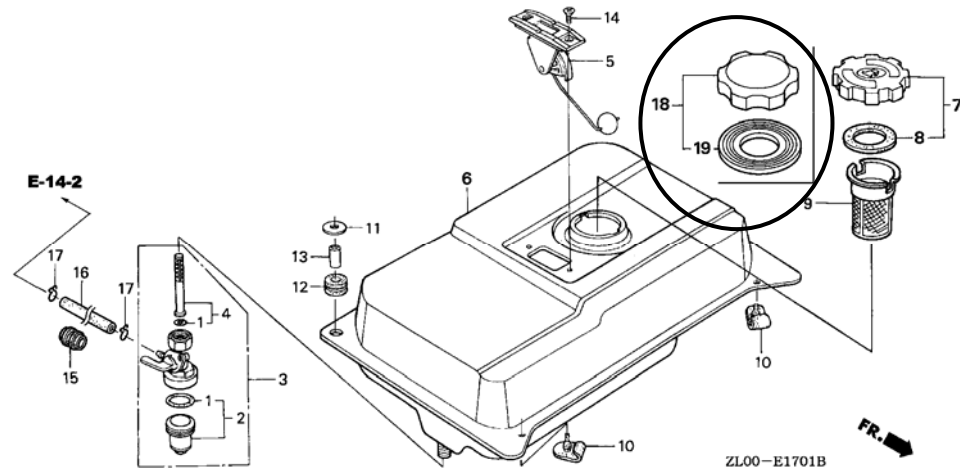

E-17-1 7 E 17620-Z0T-814 *PARTS NO. DELETION

NOTE A:PART NO. CHANGE D:NEWLY PROVIDED E:PART NO.DELETION K:REQUIRED NO. CORRECTION L:APPLICATION SERIAL NO. CORRECTION
T:APPLICATION CORRECTION Z:REMARKS CHANGE

PARTS CATALOGUE NEWS

BOOKNo. : 13ZL00E6

Block No.	Ref. No.	Note	Part No.	Description	Reqd. QTY			Serial No.	Parts catalogue code
					(1)	(2)	(3)		
	8	E	17631-Z0T-812	*PARTS NO. DELETION					
	18	D	17620-Z0T-305	CAP COMP., FUEL FILLER (CHROME PLATED)	1	-	-	1849431 -----	VMT
	19	D	17631-Z0T-812	PACKING, FUEL FILLER CAP (39X62X3)	1	-	-	1849431 -----	VMT

NOTE A:PART NO. CHANGE D:NEWLY PROVIDED E:PART NO.DELETION K:REQUIRED NO. CORRECTION L:APPLICATION SERIAL NO. CORRECTION
T:APPLICATION CORRECTION Z:REMARKS CHANGE



PARTS CATALOGUE NEWS

Honda Motor Co., Ltd. Service Division

PARTS CATALOGUE - CORRECTED

Printed in Japan

CODE NO.	BOOKLET TYPE	13ZL00E6
	MICRO-FICHE	13ZL00EF/FF
PARTS CATALOGUE TITLE	GX200 GX200[PROPANE ENGINE]	
NEWS NO.	002	

Block No.	Ref. No.	Note	Part No.	Description	Reqd. QTY	Serial No.	Parts catalogue code
					(1) (2) (3)		

E-12 FAN COVER

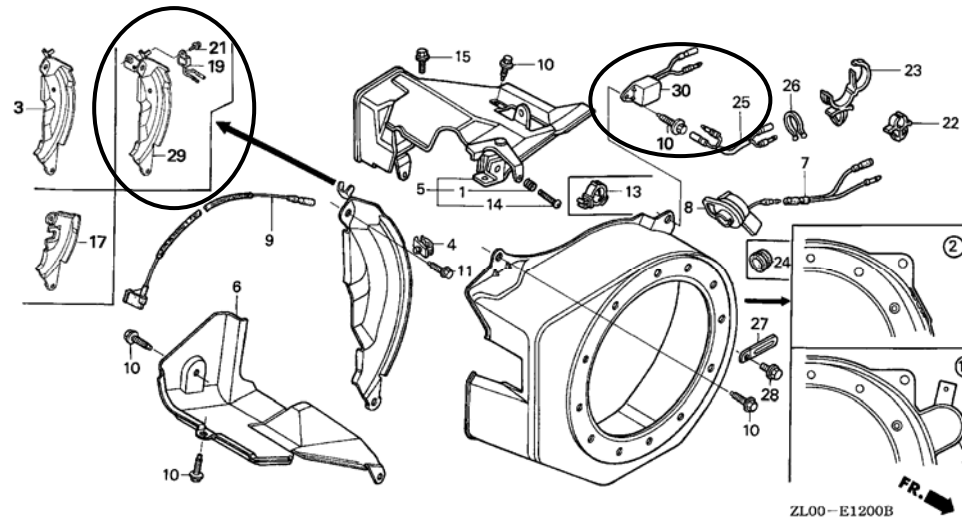

E-12 3 E 19611-ZH8-810 *PARTS NO. DELETION

NOTE A:PART NO. CHANGE D:NEWLY PROVIDED E:PART NO. DELETION K:REQUIRED NO. CORRECTION L:APPLICATION SERIAL NO. CORRECTION
T:APPLICATION CORRECTION Z:REMARKS CHANGE

PARTS CATALOGUE NEWS

BOOKNo. : 13ZL00E6

Block No.	Ref. No.	Note	Part No.	Description	Reqd. QTY			Serial No.	Parts catalogue code
					(1)	(2)	(3)		
		E	19611-ZH8-820	*PARTS NO. DELETION					
	19	T	34150-ZH7-003	ALERT UNIT, OIL	1	-	-	-----	HXU, LJC1, PXU, QG2, QXU, QX7, RXU, RX2, SM12, SM14, SM21, SM22, SM24, SXU, SX7, TXU, VAA1, VEN1, VES, VES1, VMG1, VMT, VNG4, VSD2, VSD7, VS17, VXU1
					1	-	-	----- 1289073	SMG1
					1	-	-	1156171 -----	HX, HX2, HX26, HX4, LSJ, LX, LX2, LX4, NX, PMX, PX, PX2, QX, QXC, QXC9, QXF2, QXS2, QX2, QX26, QX4, RX, RX4, SMC4, SX, SX4, TX, TX2, VAA, VA2, VEE1, VEN, VEN4, VGG2, VSD, VSD1, VX, VXU, VX2, VX4
					-	1	-		
	29	D	19611-ZH8-810	PLATE COMP. , SIDE (OIL ALERT)	1	-	-	-----	HXU, LJC1, PXU, QXU, QX7, RXU, RX2, SM12, SM14, SM21, SM22, SM24, SXU, SX7, TXU, VAA1, VEN1, VMG1, VMT, VNG4, VSD2, VSD7, VS17, VXU1
					1	-	-	----- 1584578	QG2
					1	-	-	1156171 -----	HX, HX2, HX26, HX4, LSJ, LX, LX2, LX4, NX, PMX, PX, PX2, QX, QXC, QXC9, QXF2, QX2, QX26, QX4, RX, RX4, SX, SX4, TX, TX2, VAA, VA2, VEE1, VGG2, VSD, VSD1, VX, VXU, VX2, VX4
					-	1	-	1000088	
		D	19611-ZH8-820	PLATE COMP. , SIDE (ALERT & LAMP)	1	-	-	-----	VES, VES1
					1	-	-	1156171 -----	QXS2, SMC4, VEN, VEN4
					1	-	-	1584579 -----	QG2
	30	D	34150-ZH7-003	ALERT UNIT, OIL	1	-	-	-----	SWG4

NOTE A:PART NO. CHANGE D:NEWLY PROVIDED E:PART NO.DELETION K:REQUIRED NO. CORRECTION L:APPLICATION SERIAL NO. CORRECTION
T:APPLICATION CORRECTION Z:REMARKS CHANGE



PARTS CATALOGUE NEWS

Honda Motor Co., Ltd. Service Division

PARTS CATALOGUE - CORRECTED

Printed in Japan

CODE NO.	BOOKLET TYPE	13ZL00E6
	MICRO- FICHE	13ZL00EF/FF
PARTS CATALOGUE TITLE	GX200 GX200[PROPANE ENGINE]	
NEWS NO.	003	

Block No.	Ref. No.	Note	Part No.	Description	Reqd. QTY			Serial No.	Parts catalogue code		
					(1)	(2)	(3)				
E-23	13		87529-ZE2-811	MARK, CONTROL BOX (EXTERNAL)	1	-	-	-----	-----	QXE, TXE	
					1	-	-	-----	1991201	QXE2, QXE6, QXE8, TXU1	
				87529-ZH9-W40	MARK, CONTROL BOX (ENGLISH) ..	1	-	-	-----	1965563	QXE4, SXE4
			A	87529-ZE2-812	MARK, CONTROL BOX (EXP)	1	-	-	1991202	-----	QXE2, QXE6, QXE8, TXU1
			A	87529-ZH9-W41	MARK, CONTROL BOX (ENGLISH) ..	1	-	-	1965564	-----	QXE4, SXE4
E-28	3		87521-ZL0-W80	EMBLEM	1	-	-	-----	1936815	BL	
			A	87521-ZL0-W81	1	-	-	1936816	-----	BL

NOTE A:PART NO. CHANGE D:NEWLY PROVIDED E:PART NO.DELETION K:REQUIRED NO. CORRECTION L:APPLICATION SERIAL NO. CORRECTION
T:APPLICATION CORRECTION Z:REMARKS CHANGE



PARTS CATALOGUE NEWS

Honda Motor Co., Ltd. Service Division

PARTS CATALOGUE - CORRECTED

Printed in Japan

CODE NO.	BOOKLET TYPE	13ZL00E6
	MICRO-FICHE	13ZL00EF/FF
PARTS CATALOGUE TITLE	GX200 GX200[PROPANE ENGINE]	
NEWS NO.	004	

Block No.	Ref. No.	Note	Part No.	Description	Reqd. QTY			Serial No.	Parts catalogue code	
					(1)	(2)	(3)			
E-14	10	L	16100-ZL0-821	CARBURETOR ASSY. (BE64C B) ...	1	-	-	-----	-----	LDN, LJC1, NTU, NW, NWA, NWB2, QJF, SDN
					1	-	-	-----	1113369	VEE1
					1	-	-	-----	1629601	QJF1
					1	-	-	-----	1863015	NJC1
					1	-	-	1030013	-----	LJ, LJG, LSJ, NAX, NAX1, NJ, NJG, NMB, NTB, QA, QT, SJ, SJG
					1	-	-	1030013	1122110	QAB2
					-	-	1			
	L		16100-ZK0-V01	CARBURETOR ASSY. (BE64U A) ...	1	-	-	1629602	-----	QJF1
					1	-	-	1863016	-----	NJC1

NOTE A:PART NO. CHANGE D:NEWLY PROVIDED E:PART NO. DELETION K:REQUIRED NO. CORRECTION L:APPLICATION SERIAL NO. CORRECTION
T:APPLICATION CORRECTION Z:REMARKS CHANGE



PARTS CATALOGUE NEWS

Honda Motor Co., Ltd. Service Division

PARTS CATALOGUE - CORRECTED

Printed in Japan

CODE NO.	BOOKLET TYPE	13ZL00E6
	MICRO-FICHE	13ZL00EF/FF
PARTS CATALOGUE TITLE	GX200 GX200[PROPANE ENGINE]	
NEWS NO.	005	

Block No.	Ref. No.	Note	Part No.	Description	Reqd. QTY GX200 (1) (2) (3)	Serial No.	Parts catalogue code
-----------	----------	------	----------	-------------	-----------------------------------	------------	----------------------

E-3 CYLINDER BARREL

ILLUSTRATION CORRECTED

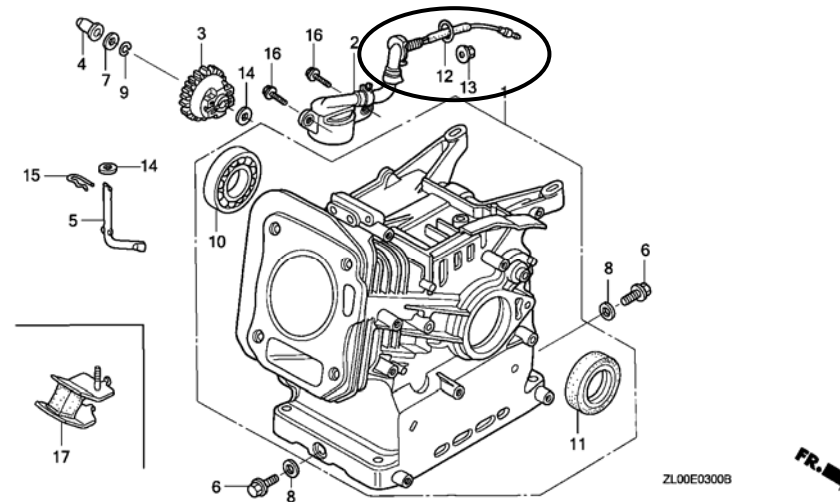

NOTE A:PART NO. CHANGE D:NEWLY PROVIDED E:PART NO. DELETION K:REQUIRED NO. CORRECTION L:APPLICATION SERIAL NO. CORRECTION
T:APPLICATION CORRECTION Z:REMARKS CHANGE



PARTS CATALOGUE NEWS

Honda Motor Co., Ltd. Service Division

PARTS CATALOGUE - CORRECTED

Printed in Japan

CODE NO.	BOOKLET TYPE	13ZL00E6
	MICRO-FICHE	13ZL00EF/FF
PARTS CATALOGUE TITLE	GX200 GX200[PROPANE ENGINE]	
NEWS NO.	006	

Block No.	Ref. No.	Note	Part No.	Description	Reqd. QTY			Serial No.	Parts catalogue code
					(1)	(2)	(3)		
E-11	1	L	28400-ZH8-013ZA	STARTER ASSY., RECOIL *R8*..... BRIGHT RED	1	1	-	-----	QG, RG, VX4P
					1	-	-	-----	1812939
					-	-	1		
	T		28400-ZH8-013YA	*R280*..... POWER RED	1	1	-	-----	QXE8, VXP

NOTE A:PART NO. CHANGE D:NEWLY PROVIDED E:PART NO.DELETION K:REQUIRED NO. CORRECTION L:APPLICATION SERIAL NO. CORRECTION
T:APPLICATION CORRECTION Z:REMARKS CHANGE

PARTS CATALOGUE NEWS

BOOKNo. : 13ZL00E6

Block No.	Ref. No.	Note	Part No.	Description	Reqd. QTY			Serial No.	Parts catalogue code
					(1)	(2)	(3)		
					1	-	-	1812940	----- BL, HX, HXQ, HXU, HX2, HX26, HX4, LD, LDB1, LDB2, LDN, LD4, LH LHB2, LHP1, LHQ4, LJ, LJC1, LJG, LSJ, LX, LX2, LX4, NDF1, NDJ, NJ NJG, NMB, NTB, NW, NWA, NWB2, NX, PMX, PX, PXU, PX2, QA, QAB2, QA2 QD, QG2, QH, QHP1, QHQ4, QH26, QH4, QJF, QM, QSW4, QT, QTP, QTP2 QX, QXB2, QXC, QXC9, QXE, QXE2, QXE4, QXE6, QXF, QXF2, QXH4, QXQ QXS2, QXU, QX2, QX26, QX4, QX7, RH, RHA2, RHQ4, RH2, RH26, RMG2 RX, RXU, RX2, RX4, SD, SDB1, SDB2, SDN, SD4, SH, SHQ4, SJ, SJG SMC4, SMG1, SM11, SM12, SM14, SM21, SM22, SM24, SX, SXE4, SXU SX4, SX7, TX, TXE, TXU, TXU1, TX2, TX4, UX, VAA, VAA1, VA2, VEE1 VGG2, VMG1, VMT, VSD, VSD1, VSD2, VSD7, VS17, VX, VXU, VXU1, VX2 VX4
	2	L	28405-ZL0-000ZB	SPACER, RECOIL STARTER MOUNTING *R8*..... BRIGHT RED	1	1	-	-----	----- NAX, NAX1, QG, RG, VX4P
					1	-	-	-----	1812939 BL, HX, HXQ, HXU, HX2, HX26, HX4, LD, LDB1, LDB2, LDN, LD4, LH LHB2, LHP1, LHQ4, LJ, LJC1, LJG, LSJ, LX, LX2, LX4, NDF1, NDJ, NJ NJC1, NJG, NMB, NTB, NW, NWA, NWB2, NX, PMX, PX, PXU, PX2, QA QAB2, QA2, QD, QG2, QH, QHP1, QHQ4, QH26, QH4, QJF, QM, QSW4, QT QTP, QTP2, QX, QXB2, QXC, QXC9, QXE, QXE2, QXE4, QXE6, QXF, QXF2 QXH4, QXQ, QXS2, QXU, QX2, QX26, QX4, QX7, RH, RHA2, RHQ4, RH2 RH26, RMG2, RX, RXU, RX2, RX4, SD, SDB1, SDB2, SDN, SD4, SH, SHQ4 SJ, SJG, SMC4, SMG1, SM11, SM12, SM14, SM21, SM22, SM24, SWG4 SX, SXE4, SXU, SX4, SX7, TX, TXE, TXU, TXU1, TX2, TX4, UX, VAA VAA1, VA2, VEE1, VGG2, VMG1, VMT, VSD, VSD1, VSD2, VSD7, VS17 VX, VXU, VXU1, VX2, VX4
					-	-	1		
		T	28405-ZL0-000ZD	*R280*..... POWER RED	1	1	-	-----	----- QXE8, VXP
					1	-	-	1812940	----- BL, HX, HXQ, HXU, HX2, HX26, HX4, LD, LDB1, LDB2, LDN, LD4, LH LHB2, LHP1, LHQ4, LJ, LJC1, LJG, LSJ, LX, LX2, LX4, NDF1, NDJ, NJ NJC1, NJG, NMB, NTB, NW, NWA, NWB2, NX, PMX, PX, PXU, PX2, QA QAB2, QA2, QD, QG2, QH, QHP1, QHQ4, QH26, QH4, QJF, QM, QSW4, QT QTP, QTP2, QX, QXB2, QXC, QXC9, QXE, QXE2, QXE4, QXE6, QXF, QXF2 QXH4, QXQ, QXS2, QXU, QX2, QX26, QX4, QX7, RH, RHA2, RHQ4, RH2 RH26, RMG2, RX, RXU, RX2, RX4, SD, SDB1, SDB2, SDN, SD4, SH, SHQ4 SJ, SJG, SMC4, SMG1, SM11, SM12, SM14, SM21, SM22, SM24, SWG4 SX, SXE4, SXU, SX4, SX7, TX, TXE, TXU, TXU1, TX2, TX4, UX, VAA VAA1, VA2, VEE1, VGG2, VMG1, VMT, VSD, VSD1, VSD2, VSD7, VS17 VX, VXU, VXU1, VX2, VX4
	3	L	28410-ZH8-003ZA	CASE COMP., RECOIL STARTER *R8*..... BRIGHT RED	1	1	-	-----	----- NAX, NAX1, QG, RG, VX4P

NOTE A:PART NO. CHANGE D:NEWLY PROVIDED E:PART NO.DELETION K:REQUIRED NO. CORRECTION L:APPLICATION SERIAL NO. CORRECTION
T:APPLICATION CORRECTION Z:REMARKS CHANGE

PARTS CATALOGUE NEWS

BOOKNo. : 13ZL00E6

Block No.	Ref. No.	Note	Part No.	Description	Reqd. QTY			Serial No.	Parts catalogue code
					(1)	(2)	(3)		
					1	-	-	----- 1812939	BL, HX, HXQ, HXU, HX2, HX26, HX4, LD, LDB1, LDB2, LDN, LD4, LH LHB2, LHP1, LHQ4, LJ, LJC1, LJG, LSJ, LX, LX2, LX4, NDF1, NDJ, NJ NJG, NMB, NTB, NW, NWA, NWB2, NX, PMX, PX, PXU, PX2, QA, QAB2, QA2 QD, QG2, QH, QHP1, QHQ4, QH26, QH4, QJF, QM, QSW4, QT, QTP, QTP2 QX, QXB2, QXC, QXC9, QXE, QXE2, QXE4, QXE6, QXF, QXF2, QXH4, QXQ QXS2, QXU, QX2, QX26, QX4, QX7, RH, RHA2, RHQ4, RH2, RH26, RMG2 RX, RXU, RX2, RX4, SD, SDB1, SDB2, SDN, SD4, SH, SHQ4, SJ, SJG SMC4, SMG1, SM11, SM12, SM14, SM21, SM22, SM24, SX, SXE4, SXU SX4, SX7, TX, TXE, TXU, TXU1, TX2, TX4, UX, VAA, VAA1, VA2, VEE1 VGG2, VMG1, VMT, VSD, VSD1, VSD2, VSD7, VS17, VX, VXU, VXU1, VX2 VX4
					-	-	1		
		T	28410-ZH8-003YA	*R280*..... POWER RED	1	1	-	-----	----- QXE8, VXP
					1	-	-	1812940 -----	BL, HX, HXQ, HXU, HX2, HX26, HX4, LD, LDB1, LDB2, LDN, LD4, LH LHB2, LHP1, LHQ4, LJ, LJC1, LJG, LSJ, LX, LX2, LX4, NDF1, NDJ, NJ NJG, NMB, NTB, NW, NWA, NWB2, NX, PMX, PX, PXU, PX2, QA, QAB2, QA2 QD, QG2, QH, QHP1, QHQ4, QH26, QH4, QJF, QM, QSW4, QT, QTP, QTP2 QX, QXB2, QXC, QXC9, QXE, QXE2, QXE4, QXE6, QXF, QXF2, QXH4, QXQ QXS2, QXU, QX2, QX26, QX4, QX7, RH, RHA2, RHQ4, RH2, RH26, RMG2 RX, RXU, RX2, RX4, SD, SDB1, SDB2, SDN, SD4, SH, SHQ4, SJ, SJG SMC4, SMG1, SM11, SM12, SM14, SM21, SM22, SM24, SX, SXE4, SXU SX4, SX7, TX, TXE, TXU, TXU1, TX2, TX4, UX, VAA, VAA1, VA2, VEE1 VGG2, VMG1, VMT, VSD, VSD1, VSD2, VSD7, VS17, VX, VXU, VXU1, VX2 VX4
E-12	2	L	19610-ZL0-000ZB	COVER COMP., FAN *R8*..... BRIGHT RED	1	-	-	-----	----- QG, RG
					1	-	-	----- 1812939	BL, HX, HXQ, HXU, HX2, HX26, HX4, LD, LDB1, LDB2, LDN, LD4, LH LHB2, LHP1, LHQ4, LJ, LJC1, LJG, LSJ, LVL, LX, LX2, LX4, NAX NDF1, NDJ, NJ, NJG, NTB, NW, NWA, NWB2, NX, PMX, PX, PXU, PX2, QA QAB2, QA2, QD, QG2, QH, QHP1, QHQ4, QH26, QJF, QM, QT, QTP, QVL QX, QXB2, QXC, QXC9, QXF, QXF2, QXQ, QXS2, QXU, QX2, QX26, QX4 QX7, RH, RHA2, RHQ4, RH2, RH26, RMG2, RX, RXU, RX2, RX4, SD, SDB1 SDB2, SDN, SD4, SH, SHQ4, SJ, SJG, SMC4, SM11, SM12, SM14, SM21 SM22, SM24, SX, SXU, SX4, SX7, TX, TXU, TX2, TX4, UX, VAA, VAA1 VA2, VEE1, VGG2, VMG1, VMT, VSD, VSD1, VSD2, VSD7, VS17, VX, VXU VXU1, VX2, VX4
					-	1	1		
		L	19610-ZL0-820ZC	*R8*..... BRIGHT RED	1	-	-	----- 1841772	NAX1, NJC1, NMB, NTU, SMG1, SMG2, SWG4

NOTE A:PART NO. CHANGE D:NEWLY PROVIDED E:PART NO.DELETION K:REQUIRED NO. CORRECTION L:APPLICATION SERIAL NO. CORRECTION
T:APPLICATION CORRECTION Z:REMARKS CHANGE

PARTS CATALOGUE NEWS

BOOKNo. : 13ZL00E6

Block No.	Ref. No.	Note	Part No.	Description	Reqd. QTY			Serial No.	Parts catalogue code
					(1)	(2)	(3)		
		T	19610-ZL0-000ZJ	*R280* POWER RED	1	-	-	1812940 -----	BL, HX, HXQ, HXU, HX2, HX26, HX4, LD, LDB1, LDB2, LDN, LD4, LH LHB2, LHP1, LHQ4, LJ, LJC1, LJG, LSJ, LVL, LX, LX2, LX4, NAX NDF1, NDJ, NJ, NJG, NTB, NW, NWA, NWB2, NX, PMX, PX, PXU, PX2, QA QAB2, QA2, QD, QG2, QH, QHP1, QHQ4, QH26, QJF, QM, QT, QTP, QVL QX, QXB2, QXC, QXC9, QXF, QXF2, QXQ, QXS2, QXU, QX2, QX26, QX4 QX7, RH, RHA2, RHQ4, RH2, RH26, RMG2, RX, RXU, RX2, RX4, SD, SDB1 SDB2, SDN, SD4, SH, SHQ4, SJ, SJG, SMC4, SM11, SM12, SM14, SM21 SM22, SM24, SX, SXU, SX4, SX7, TX, TXU, TX2, TX4, UX, VAA, VAA1 VA2, VEE1, VGG2, VMG1, VMT, VSD, VSD1, VSD2, VSD7, VS17, VX, VXU VXU1, VX2, VX4
		T	19610-ZL0-820ZF	*R280* POWER RED	1	-	-	1841773 -----	NAX1, NJC1, NMB, NTU, SMG1, SMG2, SWG4

NOTE A:PART NO. CHANGE D:NEWLY PROVIDED E:PART NO.DELETION K:REQUIRED NO. CORRECTION L:APPLICATION SERIAL NO. CORRECTION
T:APPLICATION CORRECTION Z:REMARKS CHANGE



PARTS CATALOGUE NEWS

Honda Motor Co., Ltd. Service Division

PARTS CATALOGUE - CORRECTED

Printed in Japan

CODE NO.	BOOKLET TYPE	13ZL00E6
	MICRO-FICHE	13ZL00EF/FF
PARTS CATALOGUE NEWS	GX200 GX200[PROPANE ENGINE]	
NEWS NO.	007	

Block No.	Ref. No.	Note	Part No.	Description	Reqd. QTY GX200 (1) (2) (3)	Serial No.	Parts catalogue code
-----------	----------	------	----------	-------------	-----------------------------------	------------	----------------------

E-21 STARTER MOTOR

ILLUSTRATION CORRECTED

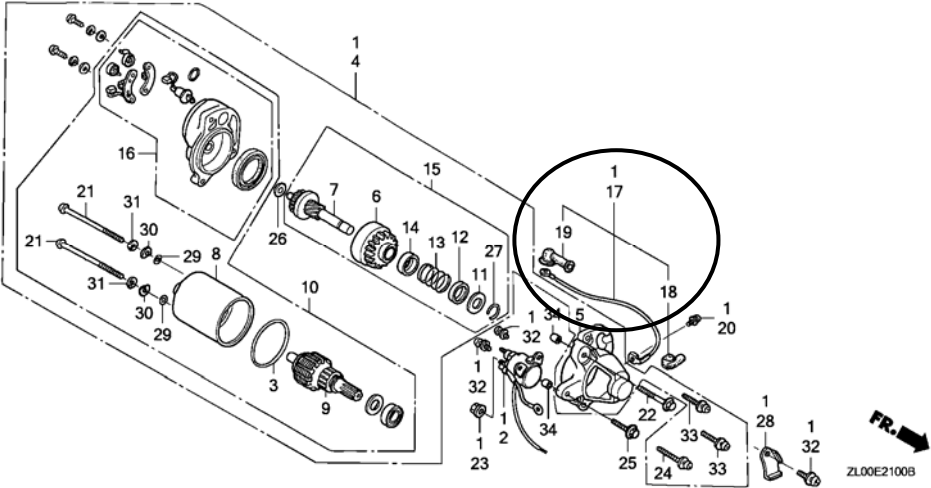

NOTE A:PART NO. CHANGE D:NEWLY PROVIDED E:PART NO.DELETION K:REQUIRED NO. CORRECTION L:APPLICATION SERIAL NO. CORRECTION
T:APPLICATION CORRECTION Z:REMARKS CHANGE



PARTS CATALOGUE NEWS

Honda Motor Co., Ltd. Service Division

PARTS CATALOGUE - CORRECTED

Printed in Japan

CODE NO.	BOOKLET TYPE	13ZL00E6
	MICRO-FICHE	13ZL00EF/FF
PARTS CATALOGUE NEWS	GX200 GX200[PROPANE ENGINE]	
NEWS NO.	008	

Block No.	Ref. No.	Note	Part No.	Description	Reqd. QTY			Serial No.	Parts catalogue code
					(1)	(2)	(3)		

PARTS NAME CORRECTED

E-14	10	Z	16100-ZL0-W51	CARBURETOR ASSY. (BE64B B/C)	1	-	-	-----	-----	QG2, QXB2, QXE8, QX7, RMG2, RX2, SM11, SM12, SM22, SWG4, SX7 VEN1, VES1, VSD7
					1	-	-	1030072	-----	HX2, HX26, LX2, PX2, QH26, QXE2, QXE6, QXF2, QXS2, QX2, QX26 RHA2, RH2, RH26, TX2, VA2, VX2
					1	-	-	1113370	-----	VEE1
					1	-	-	1122111	-----	HX, HXU, HX4, LH, LHB2, LHP1, LHQ4, LX, LX4, NX, PMX, PX, PXU, QH QHP1, QH04, QSW4, QTP, QX, QXE4, QXU, QX4, RH, RHQ4, RX, RXU, RX4 SH, SHQ4, SMC4, SX, SXE4, SXU, SX4, TX, TXE, TXU, TXU1, VNG4, VSD VX, VXU, VXU1, VX4
					1	-	-	1267449	-----	NDF1, SM14, SM21, SM24, VMG1
					1	-	-	1267449	1907885	NDJ

NOTE A:PART NO. CHANGE D:NEWLY PROVIDED E:PART NO.DELETION K:REQUIRED NO. CORRECTION L:APPLICATION SERIAL NO. CORRECTION
T:APPLICATION CORRECTION Z:REMARKS CHANGE



PARTS CATALOGUE NEWS

Honda Motor Co., Ltd. Service Division

PARTS CATALOGUE - CORRECTED

Printed in Japan

CODE NO.	BOOKLET TYPE	13ZL00E6
	MICRO-FICHE	13ZL00EF/FF
PARTS CATALOGUE NEWS	GX200 GX200[PROPANE ENGINE]	
NEWS NO.	009	

Block No.	Ref. No.	Note	Part No.	Description	Reqd. QTY GX200 (1) (2) (3)	Serial No.	Parts catalogue code
-----------	----------	------	----------	-------------	-----------------------------------	------------	----------------------

E-14 CARBURETOR (1)

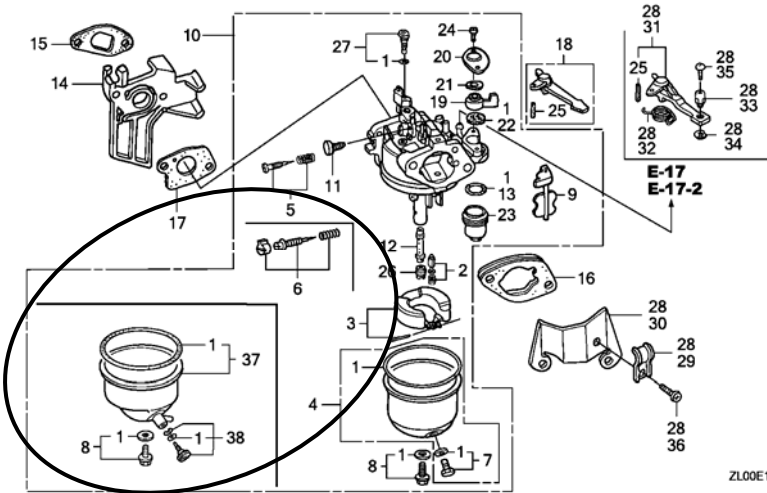

ZL00E1400B

E-14 4 E 16015-ZH7-A20 *PARTS NO. DELETION

NOTE A:PART NO. CHANGE D:NEWLY PROVIDED E:PART NO. DELETION K:REQUIRED NO. CORRECTION L:APPLICATION SERIAL NO. CORRECTION
T:APPLICATION CORRECTION Z:REMARKS CHANGE

PARTS CATALOGUE NEWS

BOOKNo. : 13ZL00E6

Block No.	Ref. No.	Note	Part No.	Description	Reqd. QTY			Serial No.	Parts catalogue code
					(1)	(2)	(3)		
		E	16015-ZH7-A21	*PARTS NO. DELETION					
	7	E	16024-ZH7-A20	*PARTS NO. DELETION					
	37	D	16015-ZH7-A20	CHAMBER SET, FLOAT (CARBURETOR NO.)	1	-	-	----- BE64R A	SMG1
		D	16015-ZH7-A21 (CARBURETOR NO.)	1	-	-	-----	SMG2
					1	-	-	BE64R B -----	SMG1
	38	D	16024-ZH7-A20	SCREW SET, DRAIN	1	-	-	-----	SMG1, SMG2

NOTE A:PART NO. CHANGE D:NEWLY PROVIDED E:PART NO.DELETION K:REQUIRED NO. CORRECTION L:APPLICATION SERIAL NO. CORRECTION
T:APPLICATION CORRECTION Z:REMARKS CHANGE



PARTS CATALOGUE NEWS

Honda Motor Co., Ltd. Service Division

PARTS CATALOGUE - CORRECTED

Printed in Japan

CODE NO.	BOOKLET TYPE	13ZL00E6
	MICRO-FICHE	13ZL00EF/FF
PARTS CATALOGUE NEWS	GX200 GX200[PROPANE ENGINE]	
NEWS NO.	010	

Block No.	Ref. No.	Note	Part No.	Description	Reqd. QTY			Serial No.	Parts catalogue code	
					(1)	(2)	(3)			
E-20	1	L	30500-ZE1-033	COIL ASSY., IGNITION	1	1	-	-----	BL, HXQ, HX4, LD, LDB1, LDB2, LDN, LD4, LJ, LJC1, LJG, LSJ, LVL, NAX, NAX1, NDF1, NJ, NJG, NMB, NTB, NTU, NW, NWA, NWB2, PMX, PX2, QA, QA2, QD, QG, QJF, QJF1, QM, QSW4, QT, QVL, QXE, QXF, QXF2, QXQ, RG, SD, SDB1, SDN, SD4, SJ, SJG, SMG1, SMG2, TXE, TX4, UX, VAA, VAA1, VA2, VEN, VES, VNG4, VX4P	
					1	-	-	-----	1741677	HX, HXU, HX2, HX26, LH, LHB2, LHP1, LHQ4, LX, LX2, LX4, NDJ, NJC1, NX, PX, PXU, QAB2, QG2, QH, QHP1, QHQ4, QH26, QH4, QTP, QTP2, QX, QXB2, QXC, QXC9, QXE2, QXE4, QXE6, QXH4, QXS2, QXU, QX2, QX26, QX4, RH, RHA2, RHQ4, RH2, RH26, RMG2, RX, RXU, RX4, SDB2, SH, SHQ4, SMC4, SM11, SM12, SM14, SM21, SM22, SM24, SX, SXE4, SXU, SX4, TX, TXU, TXU1, TX2, VEE1, VEN4, VES1, VGG2, VMG1, VMT, VSD, VSD1, VSD2, VX, VXU, VXU1, VX2, VX4
					1	-	-	-----	1741678	HX, HXU, HX2, HX26, LH, LHB2, LHP1, LHQ4, LX, LX2, LX4, NDJ, NJC1, NX, PX, PXU, QAB2, QG2, QH, QHP1, QHQ4, QH26, QH4, QTP, QTP2, QX, QXB2, QXC, QXC9, QXE2, QXE4, QXE6, QXH4, QXS2, QXU, QX2, QX26, QX4, RH, RHA2, RHQ4, RH2, RH26, RMG2, RX, RXU, RX4, SDB2, SH, SHQ4, SMC4, SM11, SM12, SM14, SM21, SM22, SM24, SX, SXE4, SXU, SX4, TX, TXU, TXU1, TX2, VEE1, VEN4, VES1, VGG2, VMG1, VMT, VSD, VSD1, VSD2, VX, VXU, VXU1, VX2, VX4
		T	30500-ZE1-043	1	1	-	-----	QXE8, QX7, RX2, SWG4, SX7, VEN1, VSD7, VS17, VXP	
					-	-	1			

NOTE A:PART NO. CHANGE D:NEWLY PROVIDED E:PART NO.DELETION K:REQUIRED NO. CORRECTION L:APPLICATION SERIAL NO. CORRECTION
T:APPLICATION CORRECTION Z:REMARKS CHANGE



PARTS CATALOGUE NEWS

Service Technology Department, Power Products Operations
 Service Division, Honda Motor Co., Ltd.

PARTS CATALOGUE - CORRECTED

Printed in Japan

CODE NO.	BOOKLET TYPE	13ZL00E6
	MICRO-FICHE	13ZL00EF/FF
PARTS CATALOGUE NEWS	GX200 GX200[PROPANE ENGINE]	
NEWS NO.	011	

Block No.	Ref. No.	Note	Part No.	Description	Reqd. QTY			Serial No.	Parts catalogue code
					(1)	(2)	(3)		
E-29	17	E	89000-ZB6-000	*PART NO. DELETION					

NOTE A:PART NO. CHANGE D:NEWLY PROVIDED E:PART NO. DELETION K:REQUIRED NO. CORRECTION L:APPLICATION SERIAL NO. CORRECTION
 M:PART DESCRIPTION CORRECTION T:APPLICATION CORRECTION Z:REMARKS CHANGE



PARTS CATALOGUE NEWS

Service Technology Department, Power Products Operations
 Service Division, Honda Motor Co., Ltd.

PARTS CATALOGUE - CORRECTED

Printed in Japan

CODE NO.	13ZL00E6
PARTS CATALOGUE NEWS	GX200 GX200[PROPANE ENGINE]
NEWS NO.	012

Block No.	Ref. No.	Note	Part No.	Description	Reqd. QTY			Serial No.	Parts catalogue code
					(1)	(2)	(3)		
E-15-2	5	M	17230-ZE1-841	COVER, AIR CLEANER (CYCLONE)...	1	-	-	-----	QH4, QTP2, QXC, QXC9, QXH4

NOTE A:PART NO. CHANGE D:NEWLY PROVIDED E:PART NO. DELETION K:REQUIRED NO. CORRECTION L:APPLICATION SERIAL NO. CORRECTION
 M:PART DESCRIPTION CORRECTION T:APPLICATION CORRECTION Z:REMARKS CHANGE