

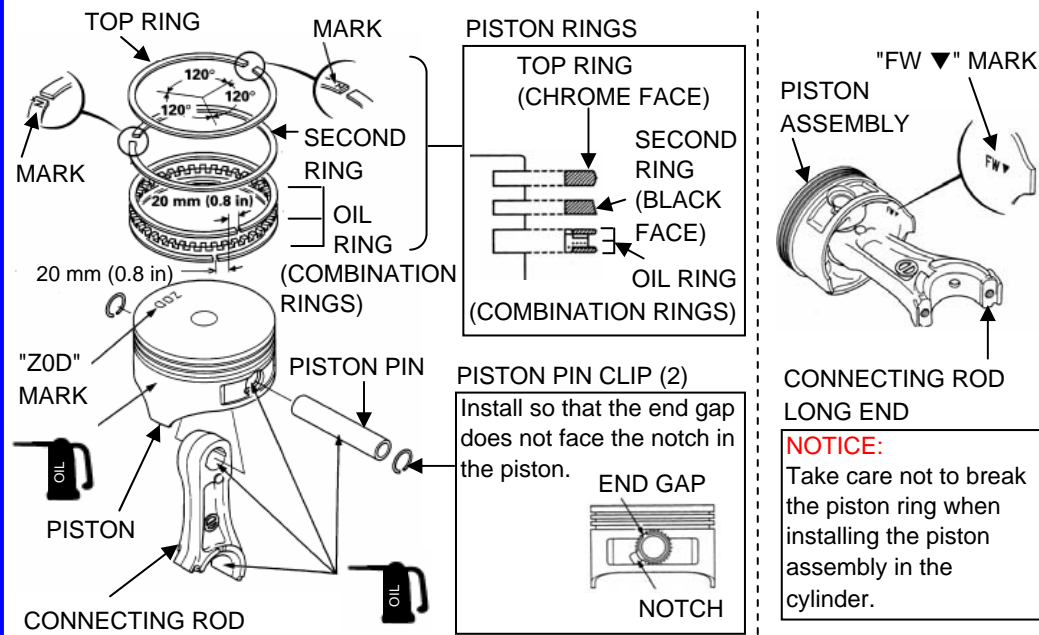

PISTON

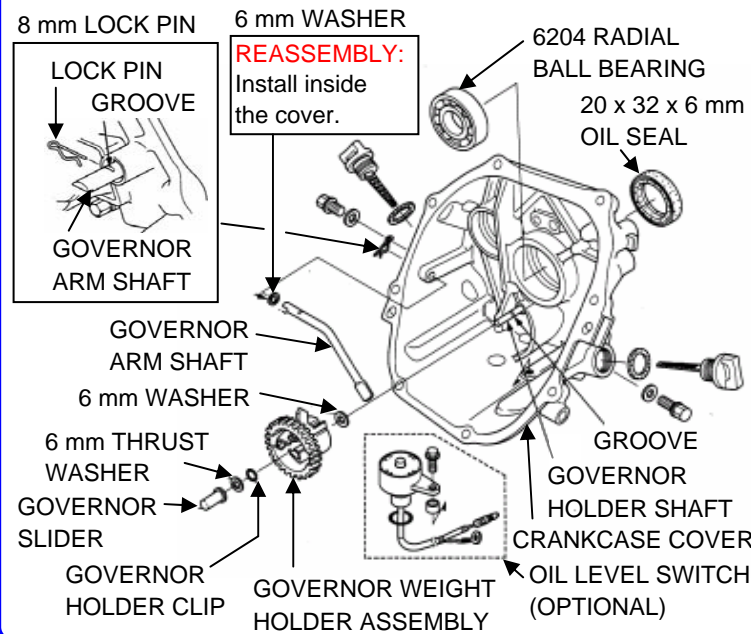

CRANKCASE COVER/GOVERNOR



VALVES/FLYWHEEL

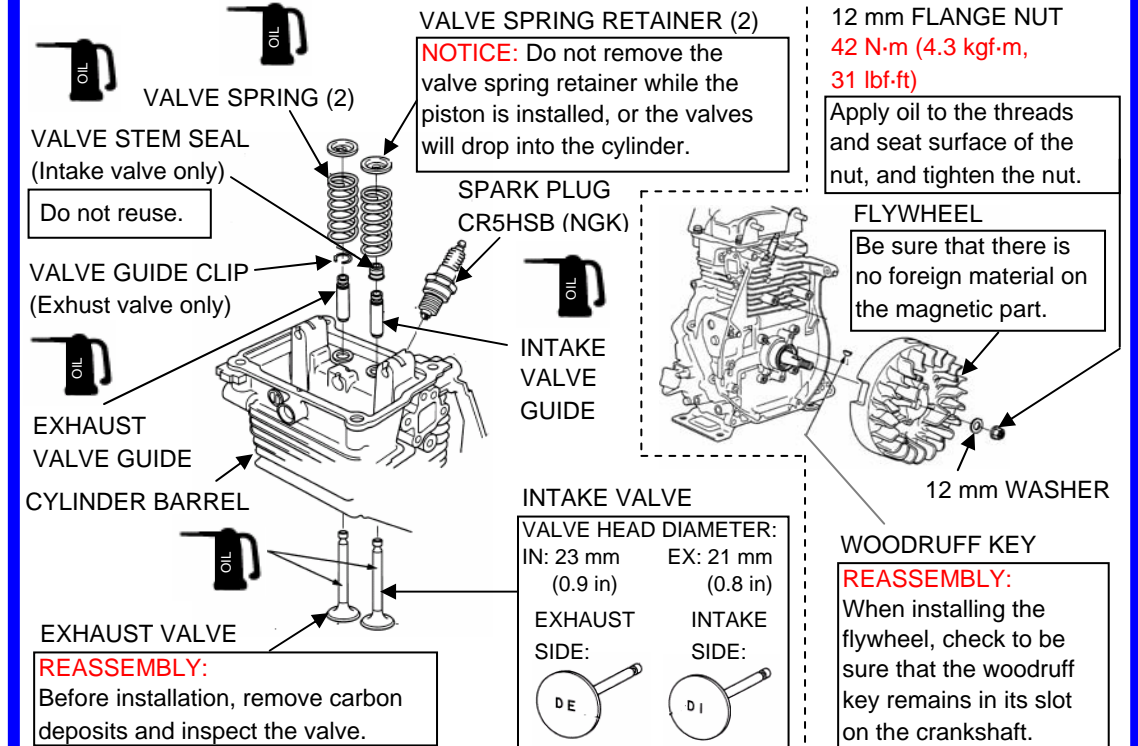

CRANKCASE COVER/CRANKSHAFT/CYLINDER BARREL

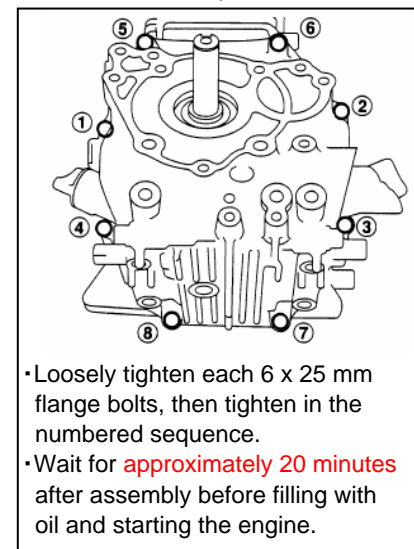
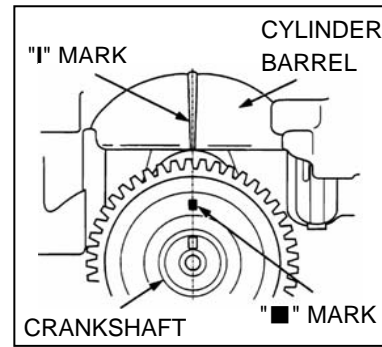
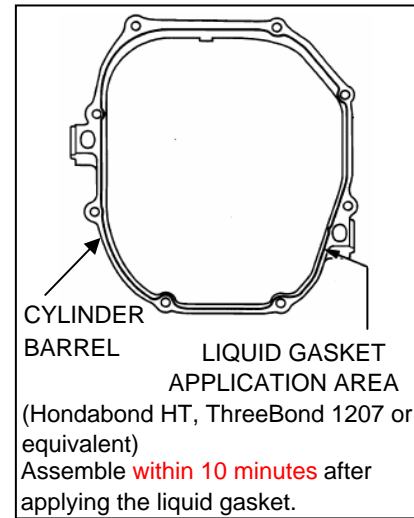
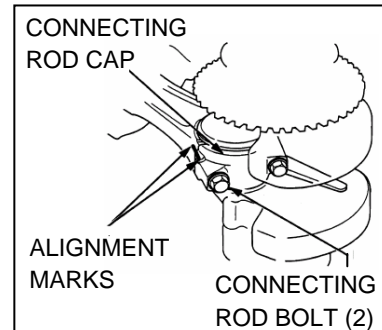
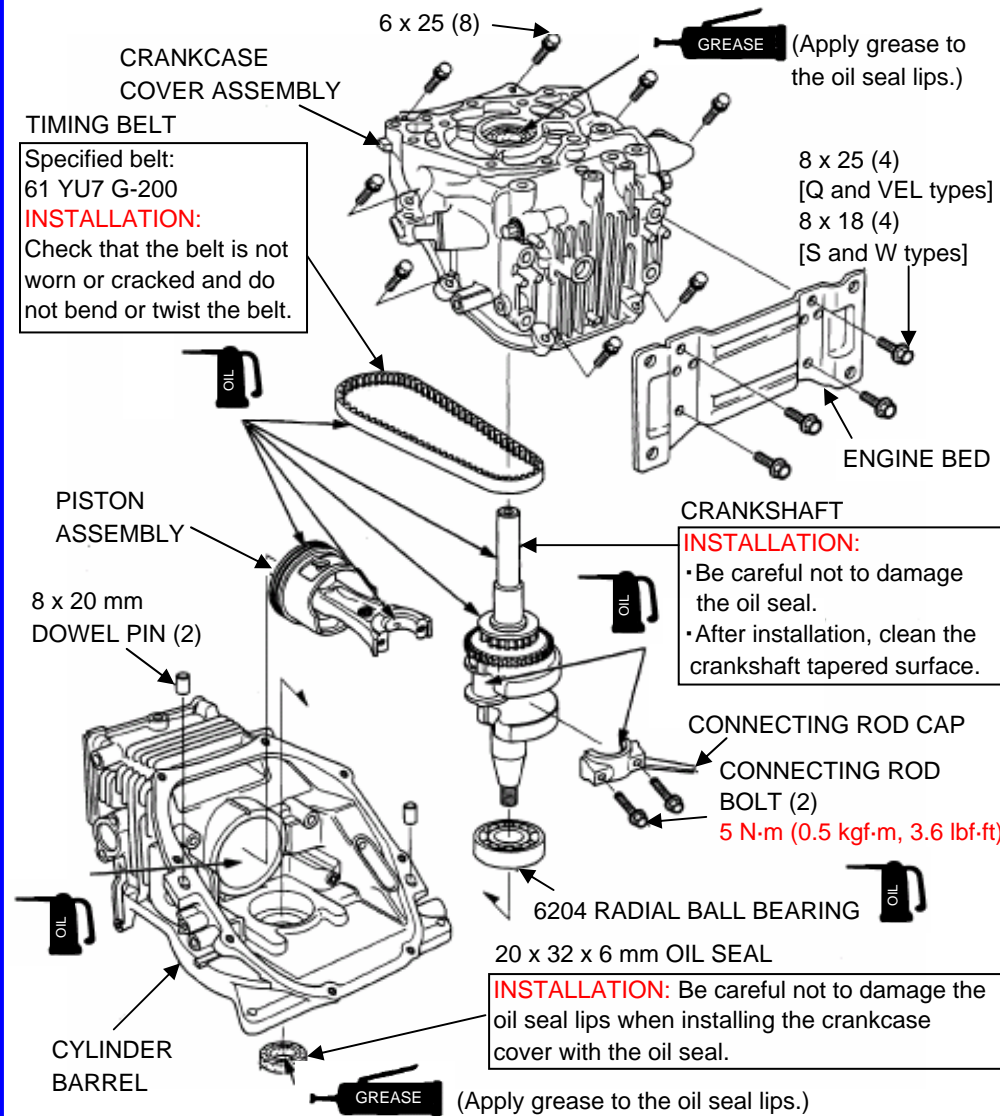

CAM PULLEY/ROCKER ARM/CYLINDER HEAD COVER

