

GENERAL PURPOSE ENGINE

**GX270
GX270
[PROPANE ENGINE]**

PARTS CATALOGUE

9



GX270

FOREWORD INDEX

1

ENGINE GROUP

2

PART NUMBER INDEX

3

PART NAME INDEX

4

Instruction for use of parts catalogue

- **This parts catalogue was prepared based on the latest information available as of January 10, 2006.**
- See the parts catalogue news for any revision that is made after January 10, 2006.
- **Always specify the part number when ordering a part.**
 - Check the model, type, serial numbers, color, maker, and the size as needed before ordering a part.
 - Note that the illustrations (part drawings) can differ from the actual parts in shape. They are given just to help you to refer to the parts.
- **When modifications or additions to this parts catalogue are made, a revised edition will be issued at an appropriate time, with successively progressing revision numbers on the cover. We recommend obtaining such revisions in order to keep your parts catalogue up-to-date at all times. To check whether a parts catalogue revision has been issued, please contact your Honda distributor.**

Initial version issue date November 20, 1990
Honda Motor Co., Ltd.

CONTENTS

	Page	Address No.	
● Instruction for use of parts catalogue	1	B 1	1
● How to refer to the part information	2	B 2	
● Part catalogue structure	3	B 3	
● When the parts were revised.....	4	B 4	
● Abbreviations used in the parts catalogue.....	4	B 4	
● How to check the part block and serial numbers.....	5	B 5	
● Models, parts catalogue codes and applicable serial numbers	6	B 6	
● Features of each type.....	17	C 1	
● Fuel hose, general purpose hoses and vinyl hose.....	33	D 1	
● FLAT RATE SERVICE TIME	34	D 2	
● Illustrated index	39	D 7	
● ENGINE GROUP.....	46	E 1	2
● PART NO. INDEX.....	285	2-G 1	3
● PART NAME INDEX.....	291	2-H 1	4

How to refer to the part information

A Reference with "Illustrated index"

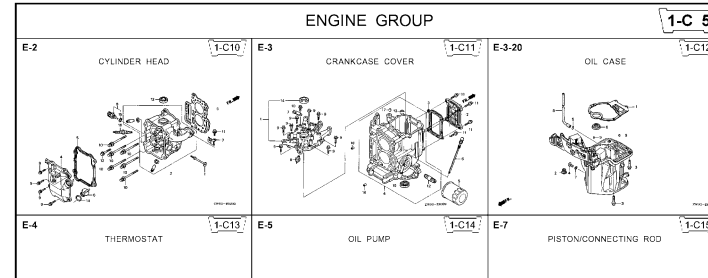

B Reference with "Part number index"

PART NO. INDEX

Part Number	Address	Page	Rel.	Part Number	Address	Page
06000				15212-ZW9-000	1-C14	3C
06316-ZW9-000	1-69	88	1	15220-ZW9-003	1-C14	3C
11000				15332-ZW9-000	1-E8	5E
11300-ZW9-405	1-C11	27	1	15332-ZW9-A30	1-E11	5E
11300-ZW9-406	1-C11	27	1	15400-PFB-004	1-C11	27
11340-ZW9-000	1-C11	27	2	15422-ZW9-000	1-C14	3C
11342-ZW9-000	1-C11	27	3	15473-881-000	1-C14	3C
11381-ZW9-003	1-C12	28	1	15474-ZW9-000	1-C14	3C
				15611-921-000	1-C10	2E
				15655-ZW9-000	1-C11	27
				16000		
12000				16010-ZV4-005	1-D4	3E
12000-ZW9-405ZA	1-C11	27	4	16011-ZV4-005	1-D4	3E
12155-ZV4-A00	1-C13	29	1	16013-ZW9-003	1-D4	3E
12166-ZW9-000	1-C10	26	1	16016-ZW9-003	1-D4	3E
12209-GB4-681	1-C16	32	1	16016-ZW9-721	1-D4	3E
12210-ZW9-405ZA	1-C10	26	2	16023-ZW9-003	1-D4	3E
12216-ZE2-300	1-E8	58	1	16024-ZV4-650	1-D4	3E
	1-E11	58	1	16028-ZV4-650	1-D4	3E

C Reference with "Part name index"

PART NAME INDEX

Part name	Address	Page	Ref.
[A]			
ABSORBER , FUEL	1-E15	62	5
ARMATURE COMP.	1-D11	43	7
ARM COMP. , LINK JOINT	1-G6	85	18
ARM COMP. , SHIFT LINK	1-G6	85	14
ARM COMP. , TILT	1-F15	79	20
ARM , FUEL PUMP ROCKER	1-C16	32	4
ARM , REVERSE LOCK	1-F15	79	18
ARM , SHIFT LINK	1-F11	74	7
ARM , STOPPER	1-D1	33	12
ARM , THROTTLE REMOTE	1-F11	74	6
ARM , VALVE ROCKER	1-C16	32	3
[B]			
BAG , TOOL , 160MM	1-G5	84	10
BAND	1-G6	86	37
BAND B1 , WIRE	1-F6	69	1
BAND , CORD	1-F3	67	18
BAND , TUBE CLIP , 11MM	1-E15	63	20
BAND , TUBE CLIP , 12.5MM	1-E15	63	19

Address No. 1-C10

E-2 CYLINDER HEAD

Block No.

Ref No.

Ref. No.	Part No.	Description	Reqd. QTY						Serial No.	Parts catalogue code
			99D1	99D1	10D1	10D1	10B1	10B1		
1	12166-ZW9-000	STOPPER, ENGINE SIDE	2	2	2	2	2	2		
2	12210-ZW9-000ZA	HEAD COMP., CYLINDER	1	1	1	1	1	1		
3	12251-ZW9-003	GASKET, CYLINDER HEAD	1	1	1	1	1	1		
4	12310-ZW9-000	COVER COMP., HEAD	1	1	1	1	1	1		
5	12312-ZW9-000	PACKING, HEAD COVER	1	1	1	1	1	1		
6	15611-921-000	CAP, OIL (NO GAUGE)	1	1	1	1	1	1		
7	16617-ZW9-000	HOLDER, CABLE	1	1	1	1	1	1	SC,SG	
	16617-ZW9-010		1	1	1	1	1	1	1001800 LHC,LHD	
			1	1	1	1	1	1	1001801 LHC,LHD	
8	35673-ZW5-003	SENSOR ASSY., WATER	1	1	1	1	1	1		
9	90003-ZW9-000	BOLT, FLANGE, 6X22	4	4	4	4	4	4		
10	90007-ZW9-003	BOLT, FLANGE, 8X83	6	6	6	6	6	6		
11	90011-ZW9-000	BOLT, FLANGE, 6X14 (CT200)	1	1	1	1	1	1		
12	90020-ZW9-000	BOLT, FLANGE, 8X40	2	2	2	2	2	2		
13	91202-KJ9-003	OIL SEAL, 20X32X6	1	1	1	1	1	1		
14	91301-805-000	O-RING, 26X2.7	1	1	1	1	1	1		
15	91307-PK2-005	O-RING, 9.5X1.5 (HONDA KIKAKI)	1	1	1	1	1	1		
16	98059-55916	PLUG, SPARK (CR5EH-9)	2	2	2	2	2	2		
	98059-55926	PLUG, SPARK (U16FER9)	2	2	2	2	2	2		

ZW83-80200

2006.09.20 E

Page No.

Part catalogue structure

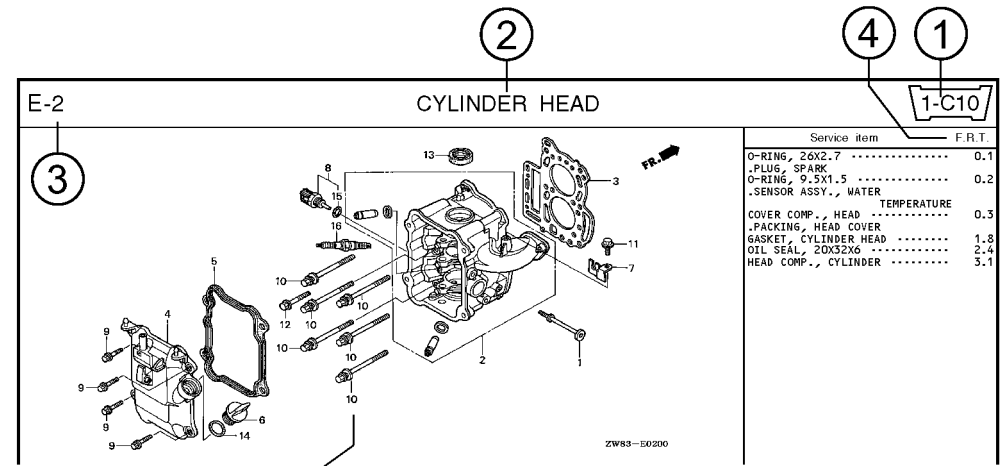

Ref. No.	Part No.	Description	Reqd. QTY						Serial No.	Parts catalogue code
			BF 9/901	BFP 9/901	BF 1001	BFP 1001	BF 1081	BFP 1081		
1	12166-zw9-000	STOPPER, ENGINE SIDE	2	2	2	2	2	2		
2	12210-zw9-000ZA	HEAD COMP., CYLINDER *NH8*	1	1	1	1	1	1		
3	12251-zw9-003	GASKET, CYLINDER HEAD	1	1	1	1	1	1		
4	12310-zw9-000	COVER COMP., HEAD	1	1	1	1	1	1		
5	12312-zw9-000	PACKING, HEAD COVER	1	1	1	1	1	1		
6	15611-921-000	CAP, OIL (NO GAUGE)	1	1	1	1	1	1		
7	16617-zw9-000	HOLDER, CABLE	1	1	1	1	1	1	SC,S6	
	16617-zw9-010		1	1	1	1	1	1	1001800 LHC,LHD	

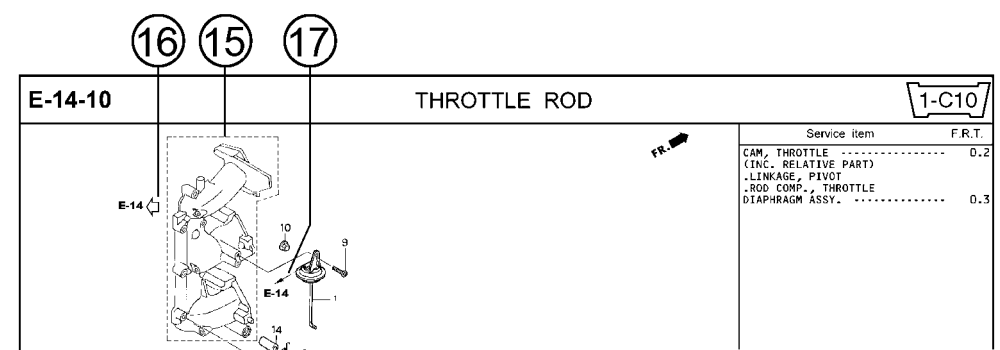

Service item	F.R.T.
.LINKAGE, PIVOT .ROD COMP., THROTTLE DIAPHRAGM ASSY.	0.3

- ① **Address number**
 - Address No. is provided (in place of the page No.) to help you refer to the part with the part No. or part name.
- ② **Block title** ③ **Block number**
- ④ **Service item/Flat rate time**
- ⑤ **Reference number**
 - Title number marked with the parenthesis or parentheses indicates that it continues from the previous page.
- ⑥ **Part number** ⑦ **Honda color code**
- ⑧ **Description**
- ⑨ **Assemblies**
 - Sections framed with broken lines in the exploded view drawings are available as complete assemblies. (Their individual parts can also be obtained.)
- ⑩ **Color description**
- ⑪ **Note**
 - Notes are shown with the parentheses in the part name column.
- ⑫ **Required quantity**
 - Required QTY shown in the parenthesis or parentheses indicates the optional part.
 - Required QTY marked with "N" Indicates the optional part that should be selected as needed.
 - Required QTY indicates the number of the part used in the block.
- ⑬ **Serial number**
- ⑭ **Type**
 - When the type column is blank, it indicates that the part is applicable to all types.
 - As the type of the actual unit may differ from the "parts catalogue, type" please refer to "Models, types and applicable serial numbers" for confirmation.
- ⑮ **[Dotted line box]**
 - Parts enclosed within a dotted line [] are covered in a different block.
- ⑯ **[Hollow arrow]**
 - A hollow arrow [] indicates the block No. for the parts enclosed within a dotted line [] .
- ⑰ **[Solid arrow]**
 - A solid arrow [] indicates the block No. the part in question is connected to.

When the parts were revised

Abbreviations used in the parts catalogue

1



Be sure to check the serial number!!



Ref. No.	Part No.	Description	Reqd. QTY						Serial No.
			BF 99D1	BFP 9.9D1	BF 10D1	BFP 10D1	BF 10B1	BFP 10B1	
1	12166-ZW9-000	STOPPER, ENGINE SIDE	2	2	2	2	2	2	
2	12210-ZW9-000ZA	HEAD COMP., CYLINDER *NH8*.....DARK GRAY	1	1	1	1	1	1	
3	12251-ZW9-003	GASKET, CYLINDER HEAD	1	1	1	1	1	1	
4	12310-ZW9-000	COVER COMP., HEAD	1	1	1	1	1	1	
5	12312-ZW9-000	PACKING, HEAD COVER	1	1	1	1	1	1	
6	15611-921-000	CAP, OIL (NO GAUGE)	1	1	1	1	1	1	
7	16617-ZW9-000	HOLDER, CABLE (###).....	1	1	1	1	1	1	SC, SG 1001800 LHC, LHD 1001801 LHC, LHD
	16617-ZW9-010	1	1	1	1	1	1	

The number has been used from the initial model without revision.

When shown at the left side, it is applicable to the models of No.1001801 and the subsequent numbers.

When shown at the right side, it is applicable to the models up to No.1001800.

• The parts listed with "###" at the end of the parts name have limited supply period (parts not for sale).

• The following abbreviations are used in the parts name column.

- | | |
|--|-----------------------------|
| A Ampere | FR.Front |
| A.C. Alternating current | IN.Inlet |
| ASSY. Assembly | L (100L) .Link (100 Links) |
| AT. Automatic transmission | L.Left |
| C.D.I. Capacitive discharge ignition | MMMillimeter |
| COMP. ... Complete | MT.Manual Transmission |
| D.C. Direct current | P.T.O.Power take off |
| EX. Exhaust | R.Right |
| G.F.C.I ... Ground fault circuit interruptor | RR.Rear |
| HEX. Hexagonal | STD.Standard |
| H.S.T. Hydrostatic transmission | T (22T) ...Tooth (22 Teeth) |
| | V Volt |
| | WWatt |

How to check the part block and serial numbers

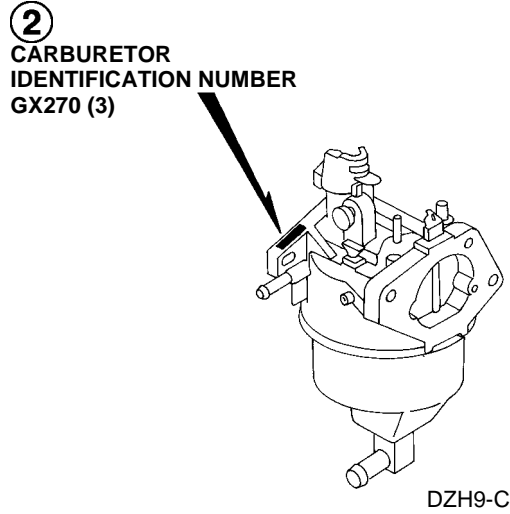
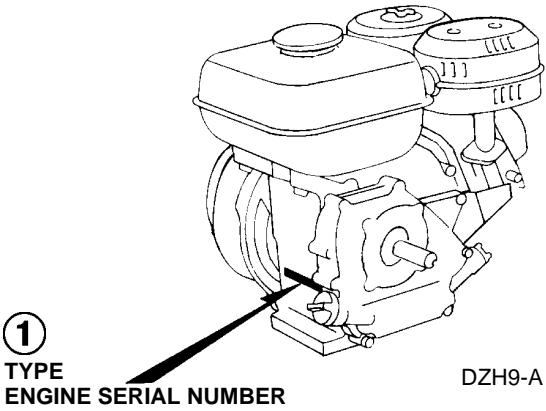
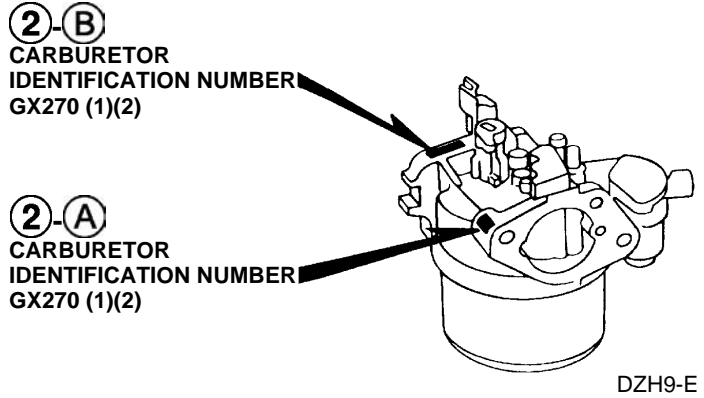
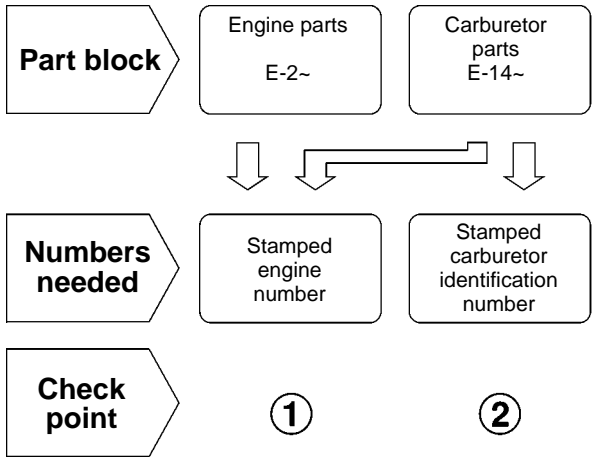

Models, parts catalogue codes and applicable serial numbers

- Models, parts catalogue codes and applicable serial Nos. given in this parts catalogue can be identified as follows.

Model	Type	Parts catalogue type	Applicable engine serial No.	Applicable carburetor identification No.	Model	Type	Parts catalogue type	Applicable engine serial No.	Applicable carburetor identification No.
GX270 (1)	ESS	ESS	GCAB-1000001~1999999	BE21E A / B	GX270 (1)	HX	HX/A	GCAB-2000001~	BE75B B
		ESS/A	GCAB-2000001~	BE21E B / C		HXQ4	HXQ4	GCAB-1000001~1999999	BE21A B / C BE75B B
	ES1	ES1	GCAB-1000001~1999999	BE21A C			HXQ4/A	GCAB-2000001~	BE75B B
		ES1/A	GCAB-2000001~	BE21A C / D		HX26	HX26	GCAB-1000001~1999999	BE75B A / B
	ES3	ES3	GCAB-1000001~1999999	BE77M A			HX26/A	GCAB-2000001~	BE75B B
		ES3/A	GCAB-2000001~						
	HA	HA	GCAB-1000001~1533484	BE21A B / C		HX8	HX8	GCAB-1000001~1999999	BE21A C BE75B B
	HAQ	HAQ		BE75A A / B			HX8/A	GCAB-2000001~	BE75B B
	HA2	HA2	GCAB-1000001~1999999	BE75B A / B		LH	LH	GCAB-1000001~1999999	BE21A B / C BE75B B
		HA2/A	GCAB-2000001~	BE75B B			LH/A	GCAB-2000001~	BE75B B
	HEA	HEA	GCAB-1000001~1533484	BE21A B / C		LHB1	LHB1	GCAB-1000001~1533484	BE21A C
	HEA2	HEA2	GCAB-1000001~1999999	BE75B A / B		LHB3	LHB3		
		HEA2/A	GCAB-2000001~	BE75B B		LHB5	LHB5	GCAB-2000001~	BE75B B
	HEA8	HEA8	GCAB-1000001~1999999			BE75B B	LHE	LHE	GCAB-1000001~1999999
		HEA8/A	GCAB-2000001~	LHE/A				GCAB-2000001~	BE75B B
	HH	HH	GCAB-1000001~1533484	BE21A B / C		LHQ4	LHQ4	GCAB-1000001~1533484	BE21A B / C
HX	HX	GCAB-1000001~1999999	BE21A B / C BE75B B	LJ	LJ	GCAB-1000001~1999999			
					LJ/A	GCAB-2000001~	BE21A C / D		

Model	Type	Parts catalogue type	Applicable engine serial No.	Applicable carburetor identification No.
GX270 (1)	LJC	LJC	GCAB-1000001~1999999	BE21A C
		LJC/A	GCAB-2000001~	BE21A C / D
	LJG	LJG	GCAB-1000001~1999999	BE21A B / C
		LJG/A	GCAB-2000001~	BE21A C / D
	LSS	LSS	GCAB-1000001~	BE21A B / C
	LT	LT	GCAB-1000001~1999999	BE21A C
		LT/A	GCAB-2000001~	BE21A C / D
	LTJ	LTJ	GCAB-1000001~	BE21A B / C
	LW	LW	GCAB-1000001~1999999	
		LW/A	GCAB-2000001~	BE21A C / D
	LWD	LWD	GCAB-1000001~1097930	BE17B A / B / C
	LWD1	LWD1	GCAB-1000001~1999999	BE21A C
		LWD1/A	GCAB-2000001~	BE21A C / D
	LX	LX	GCAB-1000001~1999999	BE21A B / C BE75B B
		LX/A	GCAB-2000001~	BE75B B
	LXE	LXE	GCAB-1000001~1999999	BE21A B / C BE75B B
LXE/A		GCAB-2000001~	BE75B B	

Model	Type	Parts catalogue type	Applicable engine serial No.	Applicable carburetor identification No.
GX270 (1)	LXE8	LXE8	GCAB-1000001~1999999	BE21A C BE75B B
		LXE8/A	GCAB-2000001~	BE75B B
	LXQ4	LXQ4	GCAB-1000001~1999999	BE21A B / C BE75B B
		LXQ4/A	GCAB-2000001~	BE75B B
	LXU	LXU	GCAB-1000001~1999999	BE21A C BE75B B
		LXU/A	GCAB-2000001~	BE75B B
	LXZ	LXZ	GCAB-1000001~1533484	BE21A B / C
	LX16	LX16	GCAB-1000001~	BE21A B / C BE75B B
	PA	PA	GCAB-1000001~1533484	BE21A B / C
	PAE2	PAE2	GCAB-1000001~1999999	BE75B B
		PAE2/A	GCAB-2000001~	
	PA2	PA2	GCAB-1000001~1999999	BE75B A / B
		PA2/A	GCAB-2000001~	BE75B B
	PX	PX	GCAB-1000001~1999999	BE21A B / C BE75B B
		PX/A	GCAB-2000001~	BE75B B
	PXE8	PXE8	GCAB-1000001~1999999	
PXE8/A		GCAB-2000001~		

1

Model	Type	Parts catalogue type	Applicable engine serial No.	Applicable carburetor identification No.	Model	Type	Parts catalogue type	Applicable engine serial No.	Applicable carburetor identification No.
GX270 (1)	PXU	PXU	GCAB-1000001~1999999	BE21A C BE75B B	GX270 (1)	QAQ	QAQ	GCAB-1000001~1533484	BE75A A / B
		PXU/A	GCAB-2000001~	BE75B B		QAQ4	QAQ4	GCAB-1000001~1999999	BE21A B / C BE75B B
	PX26	PX26	GCAB-1000001~1999999	BE75B A / B		QAQ4/A	QAQ4/A	GCAB-2000001~	BE75B B
		PX26/A	GCAB-2000001~	BE75B B		QAR2	QAR2	GCAB-1000001~1999999	BE75B A / B
	QA	QA	GCAB-1000001~1533484	BE21A B / C			QAR2/A	GCAB-2000001~	BE75B B
	QAB1	QAB1		BE21A C		QAW	QAW	GCAB-1000001~1999999	
	QAB3	QAB3	GCAB-1000001~1999999	BE21A C BE75B B			QAW/A	GCAB-2000001~	
		QAB3/A	GCAB-2000001~	BE75B B		QA2	QA2	GCAB-1000001~1999999	BE75B A / B
	QAE	QAE	GCAB-1000001~1533484	BE21A B / C			QA2/A	GCAB-2000001~	BE75B B
	QAE2	QAE2	GCAB-1000001~1999999	BE75B A / B		QD	QD	GCAB-1000001~1999999	BE21B A / B
		QAE2/A	GCAB-2000001~	BE75B B			QD/A	GCAB-2000001~	BE21B B / C
	QAE6	QAE6	GCAB-1000001~1999999	BE75B A / B		QE	QE	GCAB-1000001~1999999	BE21A B / C
		QAE6/A	GCAB-2000001~	BE75B B			QE/A	GCAB-2000001~	BE21A C / D
	QAG	QAG	GCAB-1000001~1999999			QH	QH	GCAB-1000001~1999999	BE21A B / C BE75B B
		QAG/A	GCAB-2000001~				QH/A	GCAB-2000001~	BE75B B
	QAG2	QAG2	GCAB-1000001~1999999			QHB5	QHB5	GCAB-2000001~	BE75B B
QAG2/A		GCAB-2000001~	QHC	QHC	GCAB-1000001~1533484		BE24B B / C		

Model	Type	Parts catalogue type	Applicable engine serial No.	Applicable carburetor identification No.	Model	Type	Parts catalogue type	Applicable engine serial No.	Applicable carburetor identification No.
GX270 (1)	QHE	QHE	GCAB-1000001~1533484	BE21A B / C	GX270 (1)	QKE4	QKE4	GCAB-2000001~	BE75B B
	QHE4	QHE4	GCAB-1000001~1999999	BE21A B / C BE75B B		QL2	QL2	GCAB-1000001~9999999	
		QHE4/A	GCAB-2000001~	BE75B B		QME2	QME2	GCAB-1000001~1999999	BE21A B / C BE75B B
	QHP1	QHP1	GCAB-1000001~1999999	BE21A C BE75B B			QME2/A	GCAB-2000001~	BE75B B
		QHP1/A	GCAB-2000001~	BE75B B		QMH	QMH	GCAB-1000001~1999999	BE21A C BE75B B
	QHQ4	QHQ4	GCAB-1000001~1999999	BE21A B / C BE75B B			QMH/A	GCAB-2000001~	BE75B B
		QHQ4/A	GCAB-2000001~	BE75B B		QP	QP	GCAB-1000001~1999999	BE21A B / C
	QHR	QHR	GCAB-1000001~1999999				QP/A	GCAB-2000001~	BE21A C / D
		QHR/A	GCAB-2000001~			QSC	QSC	GCAB-1000001~1533484	BE24B B / C
	QHR4	QHR4	GCAB-1000001~1999999			BE75B B	QSC9	QSC9	GCAB-1000001~1999999
		QHR4/A	GCAB-2000001~	QSC9/A				GCAB-2000001~	BE75A B
	QHZ	QHZ	GCAB-1000001~1999999	BE21A C BE75B B		QSE	QSE	GCAB-1000001~1999999	BE21A C BE75B B
		QHZ/A	GCAB-2000001~	BE75B B			QSE/A	GCAB-2000001~	BE75B B
	QH26	QH26	GCAB-1000001~1999999	BE75B A / B		QSE2	QSE2	GCAB-2000001~	BE21A C BE75B B
		QH26/A	GCAB-2000001~	BE75B B		QSE8	QSE8		
	QKE3	QKE3	GCAB-1000001~1999999	BE21A C			QSE8/A	GCAB-2000001~	BE75B B
		QKE3/A	GCAB-2000001~	BE21A C / D		QT	QT	GCAB-1000001~1999999	BE21A B / C

Model	Type	Parts catalogue type	Applicable engine serial No.	Applicable carburetor identification No.	Model	Type	Parts catalogue type	Applicable engine serial No.	Applicable carburetor identification No.
GX270 (1)	QT	QT/A	GCAB-2000001~	BE21A C / D	GX270 (1)	QXC6	QXC6	GCAB-1000001~1999999	BE75A A / B
	QWA2	QWA2	GCAB-1000001~9999999	BE75A B			QXC6/A	GCAB-2000001~	BE75A B
	QWA4	QWA4	GCAB-1000001~1999999			QXC9	QXC9	GCAB-1000001~1999999	BE75A A / B
		QWA4/A	GCAB-2000001~				QXC9/A	GCAB-2000001~	BE75A B
	QWH2	QWH2	GCAB-1000001~1999999			QXE	QXE	GCAB-1000001~1999999	BE21A B / C BE75B B
		QWH2/A	GCAB-2000001~	QXE/A			GCAB-2000001~	BE75B B	
	QX	QX	GCAB-1000001~1999999	BE21A B / C BE75B B		QXEB	QXEB	GCAB-1000001~1533484	BE21A B / C
		QX/A	GCAB-2000001~	BE75B B		QXE4	QXE4	GCAB-1000001~1999999	BE21A B / C BE75B B
	QXB	QXB	GCAB-1000001~1999999	BE21A B / C BE75B B			QXE4/A	GCAB-2000001~	BE75B B
		QXB/A	GCAB-2000001~	BE75B B		QXE6	QXE6	GCAB-1000001~1999999	BE75B A / B
	QXB6	QXB6	GCAB-1000001~1999999				QXE6/A	GCAB-2000001~	BE75B B
		QXB6/A	GCAB-2000001~			QXE8	QXE8	GCAB-1000001~1999999	BE21A C BE75B B
	QXB7	QXB7	GCAB-1000001~1999999				QXE8/A	GCAB-2000001~	BE75B B
		QXB7/A	GCAB-2000001~	QXQ4		QXQ4	GCAB-1000001~1999999	BE21A B / C BE75B B	
	QXC	QXC	GCAB-1000001~1533484			QXQ4/A	GCAB-2000001~	BE75B B	
	QXC4	QXC4	GCAB-1000001~1999999	BE24B B / C		QXU	QXU	GCAB-1000001~1999999	BE21A C BE75B B
QXC4/A		GCAB-2000001~	QXU/A		GCAB-2000001~		BE75B B		

Model	Type	Parts catalogue type	Applicable engine serial No.	Applicable carburetor identification No.	Model	Type	Parts catalogue type	Applicable engine serial No.	Applicable carburetor identification No.
GX270 (1)	QX26	QX26	GCAB-1000001~1999999	BE75B A / B	GX270 (1)	RSS	RSS	GCAB-1000001~1999999	BE75B B
		QX26/A	GCAB-2000001~	BE75B B			RSS/A	GCAB-2000001~	
	RA	RA	GCAB-1000001~1533484	BE21A B / C		RX	RX	GCAB-1000001~1999999	BE21A B / C BE75B B
	RA2	RA2	GCAB-1000001~1999999	BE75B A / B			RX/A	GCAB-2000001~	BE75B B
		RA2/A	GCAB-2000001~	BE75B B		RXQ4	RXQ4	GCAB-1000001~1999999	BE21A B / C BE75B B
	RD	RD	GCAB-1000001~1999999	BE21B A / B			RXQ4/A	GCAB-2000001~	BE75B B
		RD/A	GCAB-2000001~	BE21B B / C		RXU	RXU	GCAB-1000001~1999999	BE21A C BE75B B
	RH	RH	GCAB-1000001~	BE21A B / C BE75B B			RXU/A	GCAB-2000001~	BE75B B
	RHE	RHE	GCAB-1000001~1533484	BE21A B / C		SD	SD	GCAB-1000001~1999999	BE21B A / B
	RHE4	RHE4	GCAB-1000001~1999999	BE21A B / C BE75B B			SD/A	GCAB-2000001~	BE21B B / C
		RHE4/A	GCAB-2000001~	BE75B B		SE	SE	GCAB-1000001~1999999	BE21A B / C
	RHQ4	RHQ4	GCAB-1000001~1999999	BE21A B / C BE75B B			SE/A	GCAB-2000001~	BE21A C / D
		RHQ4/A	GCAB-2000001~	BE75B B		SH	SH	GCAB-1000001~1999999	BE21A B / C BE75B B
	RH26	RH26	GCAB-1000001~1999999	BE75B A / B			SH/A	GCAB-2000001~	BE75B B
		RH26/A	GCAB-2000001~	BE75B B		SHE	GCAB-1000001~1533484	BE21A B / C	
	RSC2	RSC2	GCAB-1000001~1999999	BE75B A / B		SHEZ			SHEZ
RSC2/A		GCAB-2000001~	BE75B B	SHQ4	SHQ4	GCAB-1000001~1999999	BE21A B / C BE75B B		

1

Model	Type	Parts catalogue type	Applicable engine serial No.	Applicable carburetor identification No.
GX270 (1)	SHQ4	SHQ4/A	GCAB-2000001~	BE75B B
	SJ	SJ	GCAB-1000001~1999999	BE21A B / C
		SJ/A	GCAB-2000001~	BE21A C / D
	SJG	SJG	GCAB-1000001~1999999	BE21A B / C
		SJG/A	GCAB-2000001~	BE21A C / D
	SJP	SJP	GCAB-1000001~1533484	BE21A B / C
	SK	SK		
	SKE1	SKE1	GCAB-1000001~1338674	BE21A C
	SMC4	SMC4	GCAB-1000001~1999999	BE21B A / B
		SMC4/A	GCAB-2000001~	BE21B B / C
	SMD	SMD	GCAB-1000001~	BE21A C BE21B B BE75B B
	SME1	SME1	GCAB-1000001~1999999	BE21A B / C BE75B B
		SME1/A	GCAB-2000001~	BE75B B
	SME6	SME6	GCAB-1000001~1999999	BE21A B / C
		SME6/A	GCAB-2000001~	BE21A C / D
SMX2	SMX2	BE75B B		

Model	Type	Parts catalogue type	Applicable engine serial No.	Applicable carburetor identification No.
GX270 (1)	SN	SN	GCAB-1000001~1999999	BE21B A / B
		SN/A	GCAB-2000001~	BE21B B / C
	SW	SW	GCAB-1000001~	BE21A B / C
	SWA4	SWA4	GCAB-2000001~	BE75B B
	SWC4	SWC4	GCAB-1000001~1999999	BE21A C BE75B B
		SWC4/A	GCAB-2000001~	BE75B B
	SWE	SWE	GCAB-1000001~1533484	BE21A B / C
	SX	SX	GCAB-1000001~1999999	BE21A B / C BE75B B
		SX/A	GCAB-2000001~	BE75B B
	SXB	SXB	GCAB-1000001~1999999	BE21A B / C BE75B B
		SXB/A	GCAB-2000001~	
	SXB7	SXB7	GCAB-1000001~1999999	BE75B B
		SXB7/A	GCAB-2000001~	
	SXE	SXE	GCAB-1000001~1999999	BE21A B / C BE75B B
		SXE/A	GCAB-2000001~	BE75B B
	SXEB	SXEB	GCAB-1000001~1999999	BE21A B / C BE75B B
		SXEB/A	GCAB-2000001~	BE75B B

Model	Type	Parts catalogue type	Applicable engine serial No.	Applicable carburetor identification No.	Model	Type	Parts catalogue type	Applicable engine serial No.	Applicable carburetor identification No.	
GX270 (1)	SXE4	SXE4	GCAB-1000001~1999999	BE21A B / C BE75B B	GX270 (1)	VDE2	VDE2	GCAB-1000001~1999999	BE75B A / B	
		SXE4/A	GCAB-2000001~	BE75B B			VDE2/A	GCAB-2000001~	BE75B B	
	SXE8	SXE8	GCAB-1000001~1999999	BE21A C BE75B B		VD16	VD16	GCAB-1000001~	BE21A B / C BE75B B	
		SXE8/A	GCAB-2000001~	BE75B B		VEB6	VEB6	GCAB-1000001~1533484		
	SXQ4	SXQ4	GCAB-1000001~1999999	BE21A B / C BE75B B		VH	VH	GCAB-1000001~		
		SXQ4/A	GCAB-2000001~	BE75B B		VKB2	VKB2	GCAB-1000001~1999999	BE75B B	
	SXU	SXU	GCAB-1000001~1999999	BE21A C BE75B B			VKB2/A	GCAB-2000001~		BE21E B / C
		SXU/A	GCAB-2000001~	BE75B B		VKE4	VKE4			BE21D B / C
	SX2	SX2	GCAB-1000001~1533484	BE75B A / B		VKX4	VKX4			BE75A B
	VA	VA		BE21A B / C		VMA4	VMA4			GCAB-1000001~1999999
	VAG2	VAG2	GCAB-1000001~1999999	BE75B B		VME2	VME2			
		VAG2/A	GCAB-2000001~			VME4	VME4	BE77Q A		
	VAW	VAW	GCAB-1000001~1533484	BE21A B / C		VMS2	VMS2	GCAB-1000001~1999999	BE77M A	
	VAW1	VAW1								
	VA2	VA2	GCAB-1000001~1999999	BE75B A / B		VMT	VMT	GCAB-2000001~	BE77Q A	
		VA2/A	GCAB-2000001~	BE75B B						
VDE	VDE	GCAB-1000001~	BE21A B / C BE75B B	VMX2	VMX2					

Model	Type	Parts catalogue type	Applicable engine serial No.	Applicable carburetor identification No.	Model	Type	Parts catalogue type	Applicable engine serial No.	Applicable carburetor identification No.
GX270 (1)	VM2	VM2	GCAB-1000001~1999999	BE75B B	GX270 (1)	VPX7	VPX7/A	GCAB-2000001~	BE21D B / C
		VM2/A	GCAB-2000001~			VSD	VSD	GCAB-1000001~1999999	BE21A B / C BE75B B
	VNG1	VNG1	GCAB-1000001~1999999	BE21A B / C BE75B B		VSD3	VSD/A	GCAB-2000001~	BE75B B
		VNG1/A	GCAB-2000001~	BE75B B			VSD3	VSD3	GCAB-1000001~1999999
	VNT2	VNT2	GCAB-1000001~1999999			BE75B B	VSD3/A	VSD3/A	GCAB-2000001~
		VNT2/A	GCAB-2000001~	VSD7			VSD7	GCAB-1000001~1999999	BE75B B
	VN17	VN17	GCAB-1000001~1999999			BE75B B	VSD7/A	GCAB-2000001~	
		VN17/A	GCAB-2000001~	VS3			VS3		VS37
	VPE4	VPE4	GCAB-1000001~1999999	BE21D B		VWA	VWA	GCAB-1000001~1533484	
		VPE4/A	GCAB-2000001~	BE21D B / C			VWA2	VWA2	GCAB-1000001~1999999
	VPE5	VPE5		BE77R A		VWA2/A		GCAB-2000001~	BE75B B
	VPE7	VPE7	GCAB-1000001~1999999	BE21D B		VWN2	VWN2	GCAB-1000001~1999999	BE75B A / B
		VPE7/A	GCAB-2000001~	BE21D B / C			VWN2/A	GCAB-2000001~	BE75B B
	VPX4	VPX4	GCAB-1000001~1999999	BE21D B		VWT4	VWT4	GCAB-1000001~1999999	BE21A C
		VPX4/A	GCAB-2000001~	BE21D B / C					
	VPX5	VPX5		BE77R A					
VPX7	VPX7	GCAB-1000001~1999999	BE21D B						

Model	Type	Parts catalogue type	Applicable engine serial No.	Applicable carburetor identification No.	Model	Type	Parts catalogue type	Applicable engine serial No.	Applicable carburetor identification No.	
GX270 (1)	VWT4	VWT4/A	GCAB-2000001~	BE21A C / D	GX270 (1)	VXE6	VXE6	GCAB-1000001~1999999	BE75B B	
	VW12	VW12	GCAB-1000001~1999999	BE75B A / B			VXE6/A	GCAB-2000001~		
		VW12/A	GCAB-2000001~	BE75B B		VXE7	VXE7	GCAB-1000001~1999999		
	VW22	VW22	GCAB-1000001~	BE75B A / B			VXE7/A	GCAB-2000001~		
	VX	VX	GCAB-1000001~1999999	BE21A B / C BE75B B		VXG	VXG	GCAB-1000001~		BE21A B / C BE75B B
		VX/A	GCAB-2000001~	BE75B B		VXQ4	VXQ4	GCAB-1000001~1999999		BE75B B
	VXB	VXB	GCAB-1000001~1999999	BE21A B / C BE75B B			VXQ4/A	GCAB-2000001~		
		VXB/A	GCAB-2000001~	BE75B B		VXTB	VXTB	GCAB-1000001~1305066	BE21A C BE75B B	
	VXB2	VXB2	GCAB-1000001~	BE75B A / B		VXT1	VXT1	GCAB-1000001~1999999	BE21A C	
	VXB6	VXB6	GCAB-1000001~1533484				VXT1/A	GCAB-2000001~	BE21A C / D	
	VXB7	VXB7	GCAB-1000001~1999999	BE75B B		VXU	VXU	GCAB-1000001~1999999	BE21A B / C BE75B B	
		VXB7/A	GCAB-2000001~				VXU/A	GCAB-2000001~	BE75B B	
	VXE	VXE	GCAB-1000001~	BE21A B / C BE75B B		VXU1	VXU1	GCAB-1000001~1999999	BE21A C BE75B B	
	VXEB	VXEB	GCAB-1000001~1999999				VXU1/A	GCAB-2000001~	BE75B B	
		VXEB/A	GCAB-2000001~	BE75B B		VX26	VX26	GCAB-1000001~	BE75B A / B	
	VXE4	VXE4	GCAB-1000001~1999999	BE21A B / C BE75B B		WMA4	WMA4	GCAB-2000001~	BE76C A	
VXE4/A		GCAB-2000001~	BE75B B	WMT8	WMT8	GCAB-1000001~1999999	BE21B B BE76C A			

Model	Type	Parts catalogue type	Applicable engine serial No.	Applicable carburetor identification No.	Model	Type	Parts catalogue type	Applicable engine serial No.	Applicable carburetor identification No.
GX270 (1)	WMT8	WMT8/A	GCAB- 2000001~	BE76C A	GX270 (2)	S1	S1	GCAB- 1000001~1999999	BE21A B / C BE21B A / B BE24B B / C
	WXE8	WXE8	GCAB- 1000001~1999999				S1/A	GCAB- 2000001~	BE21A C / D BE21B B / C BE24B C / D
		WXE8/A	GCAB- 2000001~			V1	V1	GCAB- 1000001~1533484	BE21B A / B
GX270 (2)	L1	L1	GCAB- 1000001~1999999	BE21A B / C BE21B A / B BE24B B / C		W1	W1	GCAB- 1000001~1999999	BE21A B / C BE21B A / B BE24B B / C
		L1/A	GCAB- 2000001~	BE21A C / D BE21B B / C BE24B C / D			W1/A	GCAB- 2000001~	BE21A C / D BE21B B / C BE24B C / D
	Q1	Q1	GCAB- 1000001~1999999	BE21A B / C BE21B A / B BE24B B / C		GX270 (3) (Propane)	HAP	HAP	GDAD- 1000001~1099999
		Q1/A	GCAB- 2000001~	BE21A C / D BE21B B / C BE24B C / D	HAP/A			GDAD- 1100001~	
	Q2	Q2	GCAB- 1000001~1533484	BE21A B BE21B A BE24B B / C	RXP		RXP	GDAD- 1000001~1099999	
	R1	R1	GCAB- 1000001~1999999	BE21A B / C BE21B A / B BE24B B / C			VXP	VXP	GDAD- 1000001~1099999
		R1/A	GCAB- 2000001~	BE21A C / D BE21B B / C BE24B C / D	VXP/A	VXP/A	GDAD- 1100001~		
	VXQP	VXQP	GDAD- 1000001~1000029						

* Of carburetor identification numbers, only the portions underlined in the example below are used for registration.

GX270 (1)(2) BE 21E A KC †
 (A) (B)
 GX270 (3) BEL3A A KC †

Features of each type

• See the following table for the features of each type. (Items in brackets are optional)

Specifications		Model		GX270											
		Type		Standard equipment (1)											
		ESS	ES1	ES3	HA	HAQ	HA2	HEA	HEA2	HEA8	HH	HX	HXQ4	HX26	HX8
Crankshaft	25mm Ø Straight														
	25.4mm Ø Straight														
	20mm Ø Spline				●	●	●	●	●	●	●	●	●	●	●
	M20 Stepped thread														
	1" Thread														
	M10 Tapered	●	●	●											
	5/16" Tapered														
Reduction	1/2 Reduction														
	1/2 Reduction (With clutch)														
	1/6 Reduction				●	●	●	●	●	●	●	●	●	●	●
Coil	Lamp coil														
	Charge coil						●	●	●						
Fuel tank	●	●		●	●	●	●	●	●	●	●	●	●	●	●
Control box							●	●	●						
Starter motor							●	●	●						
Oil alert	●	●	●	●		●		●	●		●	●	●	●	●



1

Specifications		Model	GX270												
		Type	Standard equipment (1)												
		LH	LHB1	LHB3	LHB5	LHE	LHQ4	LJ	LJC	LJG	LSS	LT	LTJ	LW	LWD
Crankshaft	25mm Ø Straight														
	25.4mm Ø Straight														
	20mm Ø Spline	●	●	●	●	●	●	●	●	●	●	●	●	●	●
	M20 Stepped thread														
	1" Thread														
	M10 Tapered														
	5/16" Tapered														
Reduction	1/2 Reduction	●	●	●	●	●	●	●	●	●	●	●	●	●	●
	1/2 Reduction (With clutch)														
	1/6 Reduction														
Coil	Lamp coil											●	●	●	
	Charge coil					●							●		●
Fuel tank		●	●	●	●	●	●	●	●	●	●	●	●	●	●
Control box						●							●		
Starter motor						●							●		●
Oil alert									●						

Specifications		Model	GX270												
		Type	Standard equipment (1)												
			LWD1	LX	LXE	LXE8	LXQ4	LXU	LXZ	LX16	PA	PAE2	PA2	PX	PXE8
Crankshaft	25mm Ø Straight														
	25.4mm Ø Straight														
	20mm Ø Spline	●	●	●	●	●	●	●	●						
	M20 Stepped thread														
	1" Thread									●	●	●	●	●	●
	M10 Tapered														
	5/16" Tapered														
Reduction	1/2 Reduction	●	●	●	●	●	●	●	●						
	1/2 Reduction (With clutch)														
	1/6 Reduction														
Coil	Lamp coil														
	Charge coil	●		●	●						●			●	
Fuel tank		●	●	●	●	●	●	●	●	●	●	●	●	●	●
Control box				●	●						●			●	
Starter motor		●		●	●						●			●	
Oil alert			●	●	●	●	●	●	●	●	●	●	●	●	●

Specifications		Model	GX270												
		Type	Standard equipment (1)												
			PX26	QA	QAB1	QAB3	QAE	QAE2	QAE6	QAG	QAG2	QAQ	QAQ4	QAR2	QAW
Crankshaft	25mm Ø Straight														
	25.4mm Ø Straight		●	●	●	●	●	●	●	●	●	●	●	●	●
	20mm Ø Spline														
	M20 Stepped thread														
	1" Thread	●													
	M10 Tapered														
	5/16" Tapered														
Reduction	1/2 Reduction														
	1/2 Reduction (With clutch)														
	1/6 Reduction														
Coil	Lamp coil														
	Charge coil					●	●	●	●				●		
Fuel tank		●	●	●	●	●	●	●	●	●	●	●	●	●	●
Control box					●	●	●								
Starter motor					●	●	●								
Oil alert		●	●		●	●	●	●	●			●	●	●	●

Specifications		Model	GX270												
		Type	Standard equipment (1)												
			QD	QE	QH	QHB5	QHC	QHE	QHE4	QHP1	QHQ4	QHR	QHR4	QHZ	QH26
Crankshaft	25mm Ø Straight														
	25.4mm Ø Straight	●	●	●	●	●	●	●	●	●	●	●	●	●	●
	20mm Ø Spline														
	M20 Stepped thread														
	1" Thread														
	M10 Tapered														
	5/16" Tapered														
Reduction	1/2 Reduction														
	1/2 Reduction (With clutch)														
	1/6 Reduction														
Coil	Lamp coil										●				
	Charge coil						●	●				●			●
Fuel tank		●	●	●	●	●	●	●	●	●	●	●	●	●	●
Control box							●	●							
Starter motor							●	●				●			●
Oil alert															●

Specifications		Model	GX270													
		Type	Standard equipment (1)													
			QKE4	QL2	QME2	QMH	QP	QSC	QSC9	QSE	QSE2	QSE8	QT	QWA2	QWA4	QWH2
Crankshaft	25mm Ø Straight															
	25.4mm Ø Straight	●	●	●	●	●	●	●	●	●	●	●	●	●	●	●
	20mm Ø Spline															
	M20 Stepped thread															
	1" Thread															
	M10 Tapered															
	5/16" Tapered															
Reduction	1/2 Reduction															
	1/2 Reduction (With clutch)															
	1/6 Reduction															
Coil	Lamp coil					●										
	Charge coil	●	●	●			●	●	●	●	●					
Fuel tank		●	●	●	●	●	●	●	●	●	●	●	●	●	●	●
Control box				●			●	●	●	●	●					
Starter motor		●		●			●	●	●	●	●					
Oil alert			●	●				●	●	●	●		●	●	●	

Specifications		GX270													
		Standard equipment (1)													
		QX	QXB	QXB6	QXB7	QXC	QXC4	QXC6	QXC9	QXE	QXEB	QXE4	QXE6	QXE8	QXQ4
Crankshaft	25mm Ø Straight														
	25.4mm Ø Straight	●	●	●	●	●	●	●	●	●	●	●	●	●	●
	20mm Ø Spline														
	M20 Stepped thread														
	1" Thread														
	M10 Tapered														
	5/16" Tapered														
Reduction	1/2 Reduction														
	1/2 Reduction (With clutch)														
	1/6 Reduction														
Coil	Lamp coil														
	Charge coil			●						●	●	●	●	●	
Fuel tank		●	●	●	●	●	●	●	●	●	●	●	●	●	●
Control box				●						●	●	●	●	●	
Starter motor				●						●	●	●	●	●	
Oil alert		●	●	●	●	●	●	●	●	●	●	●	●	●	●

Specifications		Model	GX270													
		Type	Standard equipment (1)													
			QXU	QX26	RA	RA2	RD	RH	RHE	RHE4	RHQ4	RH26	RSC2	RSS	RX	RXQ4
Crankshaft	25mm Ø Straight				●	●	●	●	●	●	●	●	●	●	●	●
	25.4mm Ø Straight	●	●													
	20mm Ø Spline															
	M20 Stepped thread															
	1" Thread															
	M10 Tapered															
	5/16" Tapered															
Reduction	1/2 Reduction															
	1/2 Reduction (With clutch)			●	●	●	●	●	●	●	●	●	●	●	●	●
	1/6 Reduction															
Coil	Lamp coil												●	●		
	Charge coil								●	●						
Fuel tank		●	●	●	●	●	●	●	●	●	●	●		●	●	●
Control box									●	●						
Starter motor									●	●						
Oil alert		●	●	●	●								●		●	●

Specifications		Model	GX270													
		Type	Standard equipment (1)													
			RXU	SD	SE	SH	SHE	SHEZ	SHQ4	SJ	SJG	SJP	SK	SKE1	SMC4	SMD
Crankshaft	25mm Ø Straight	●	●	●	●	●	●	●	●	●	●	●	●	●	●	
	25.4mm Ø Straight															
	20mm Ø Spline															
	M20 Stepped thread															
	1" Thread															
	M10 Tapered															
	5/16" Tapered															
Reduction	1/2 Reduction															
	1/2 Reduction (With clutch)	●														
	1/6 Reduction															
Coil	Lamp coil													●		
	Charge coil					●	●						●			
Fuel tank		●	●	●	●	●	●	●	●	●	●	●		●	●	
Control box						●	●									
Starter motor						●	●					●				
Oil alert		●									●			●	●	

Specifications		Model	GX270													
		Type	Standard equipment (1)													
			SME1	SME6	SMX2	SN	SW	SWA4	SWC4	SWE	SX	SXB	SXB7	SXE	SXEB	SXE4
Crankshaft	25mm Ø Straight		●	●	●	●	●	●	●	●	●	●	●	●	●	●
	25.4mm Ø Straight															
	20mm Ø Spline															
	M20 Stepped thread															
	1" Thread															
	M10 Tapered															
	5/16" Tapered															
Reduction	1/2 Reduction															
	1/2 Reduction (With clutch)															
	1/6 Reduction															
Coil	Lamp coil					●										
	Charge coil		●	●						●				●	●	●
Fuel tank			●	●	●	●	●	●	●	●	●	●	●	●	●	●
Control box			●							●				●	●	●
Starter motor			●							●				●	●	●
Oil alert			●	●	●			●	●		●	●	●	●	●	●

Specifications		Model	GX270												
		Type	Standard equipment (1)												
			SXE8	SXQ4	SXU	SX2	VA	VAG2	VAW	VAW1	VA2	VDE	VDE2	VD16	VEB6
Crankshaft	25mm Ø Straight	●	●	●	●										
	25.4mm Ø Straight														
	20mm Ø Spline														
	M20 Stepped thread														
	1" Thread														
	M10 Tapered														
	5/16" Tapered					●	●	●	●	●	●	●	●	●	●
Reduction	1/2 Reduction														
	1/2 Reduction (With clutch)														
	1/6 Reduction														
Coil	Lamp coil														
	Charge coil	●									●	●		●	
Fuel tank		●	●	●	●	●				●			●	●	●
Control box		●									●	●		●	
Starter motor		●									●	●		●	
Oil alert		●	●	●		●	●	●		●	●	●	●	●	

Specifications		Model	GX270												
		Type	Standard equipment (1)												
			VKB2	VKE4	VKX4	VMA4	VME2	VME4	VMS2	VMT	VMX2	VM2	VNG1	VNT2	VN17
Crankshaft	25mm Ø Straight														
	25.4mm Ø Straight														
	20mm Ø Spline														
	M20 Stepped thread														
	1" Thread														
	M10 Tapered				●		●		●						
	5/16" Tapered	●	●	●		●		●		●	●	●	●	●	●
Reduction	1/2 Reduction														
	1/2 Reduction (With clutch)														
	1/6 Reduction														
Coil	Lamp coil							●		●					
	Charge coil	●	●			●	●	●							●
Fuel tank				●	●	●		●		●					
Control box		●			●		●								
Starter motor		●	●			●	●	●							●
Oil alert		●	●	●	●	●	●	●	●	●	●	●	●	●	●

Specifications		Model	GX270													
		Type	Standard equipment (1)													
			VPE5	VPE7	VPX4	VPX5	VPX7	VSD	VSD3	VSD7	VSH7	VS3	VS37	VWA	VWA2	VWN2
Crankshaft	25mm Ø Straight															
	25.4mm Ø Straight															
	20mm Ø Spline															
	M20 Stepped thread															
	1" Thread															
	M10 Tapered															
	5/16" Tapered	●	●	●	●	●	●	●	●	●	●	●	●	●	●	
Reduction	1/2 Reduction															
	1/2 Reduction (With clutch)															
	1/6 Reduction															
Coil	Lamp coil															
	Charge coil	●	●													
Fuel tank							●		●							
Control box																
Starter motor		●	●													
Oil alert		●	●	●	●	●	●	●	●	●	●	●	●	●	●	●

1

Specifications		Model	GX270												
		Type	Standard equipment (1)												
		VWT4	VW12	VW22	VX	VXB	VXB2	VXB6	VXB7	VXE	VXEB	VXE4	VXE6	VXE7	VXG
Crankshaft	25mm Ø Straight														
	25.4mm Ø Straight														
	20mm Ø Spline														
	M20 Stepped thread														
	1" Thread														
	M10 Tapered														
	5/16" Tapered	●	●	●	●	●	●	●	●	●	●	●	●	●	●
Reduction	1/2 Reduction														
	1/2 Reduction (With clutch)														
	1/6 Reduction														
Coil	Lamp coil														
	Charge coil									●	●	●	●	●	
Fuel tank			●	●	●	●	●	●	●	●	●	●	●	●	●
Control box										●	●	●	●	●	
Starter motor		●								●	●	●	●	●	
Oil alert		●	●	●	●	●	●		●	●	●	●	●	●	●

Specifications		Model	GX270							
		Type	Standard equipment (1)							
			VXQ4	VXTB	VXT1	VXU	VXU1	VX26	WMA4	WMT8
Crankshaft	25mm Ø Straight									
	25.4mm Ø Straight									
	20mm Ø Spline									
	M20 Stepped thread							●	●	●
	1" Thread									
	M10 Tapered									
	5/16" Tapered	●	●	●	●	●	●			
Reduction	1/2 Reduction									
	1/2 Reduction (With clutch)									
	1/6 Reduction									
Coil	Lamp coil									
	Charge coil							●		●
Fuel tank		●	●		●	●	●	●	●	●
Control box								●		●
Starter motor								●		●
Oil alert		●	●	●	●	●	●	●	●	●

Specifications		GX270										
		Model	Selective equipment (2)						Propane (3)			
		Type	L1	Q1	Q2	R1	S1	V1	W1	HAP	RXP	VXP
Crankshaft	25mm Ø Straight				●	●				●		
	25.4mm Ø Straight		●	●								
	20mm Ø Spline	●							●			
	M20 Stepped thread							●				
	1" Thread											
	M10 Tapered											
	5/16" Tapered						●				●	●
Reduction	1/2 Reduction	●										
	1/2 Reduction (With clutch)				●					●		
	1/6 Reduction								●			
Coil	Lamp coil	(●)	(●)	(●)	(●)	(●)	(●)	(●)				
	Charge coil	(●)	(●)	(●)	(●)	(●)	(●)	(●)				
Fuel tank		(●)	(●)	(●)	(●)	(●)	(●)	(●)				
Control box		(●)	(●)	(●)	(●)	(●)	(●)	(●)				
Starter motor		(●)	(●)	(●)	(●)	(●)	(●)	(●)				
Oil alert		(●)	(●)	(●)	(●)	(●)	(●)	(●)	●	●	●	●

Fuel hose, general purpose hoses and vinyl hose

- The standard part fuel hose, general purpose hose and vinyl hose may be substituted by the coiled bulk part.
- When ordering the standard part fuel hose, general purpose hose and vinyl hose use the bulk part number written in the parts catalog in brackets () underneath the part name.
- When exchanging the hose, cut and use at the specified length as mentioned in the part name.
(For the method of cutting the bulk part, and method of filling out orders etc., please refer to the instructions issued with the bulk part.)

Bulk part number of fuel hose, general purpose hose and vinyl hose.

Example: 9 5 0 0 1 - 7 5 0 0 1 - 5 0 M

Bulk part number:
Refers to the bulk part.

Marking code (fuel hose and general purpose hose)

Change code (Vinyl hose)

Indicates number mark or change sequence, however, the code for the bulk part must be strictly 0 (zero).

Types of code:

- | | | | | | |
|-------------|--|----------------|--|--------------|---|
| • Fuel hose | 2: Red outside braid
(3 mm inside dia. only) | • General hose | 1: Ash gray
2: Ash gray
3: Black
5: Black | • Vinyl hose | 1: Clear
2: Black
3: Light red
6: Light red
7: Pale black |
| | 5: Black inside braid | | | | |
| | 3: Red (3 mm inside dia. only) | | | | |
| | 4: Ash gray with red stripe
(3 mm inside dia. only) | | | | |
| | 6: Black | | | | |

Lengths:

- 001: 1 m (standard)
003: 3 m
008: 8 m } Application or specification of some parts is not settled.

I.D code: (fuel hose and general purpose hose)

- | | | | | |
|------------|--------------------|--------------------|-----------------------------|-----------------------------|
| 30: 3.0 mm | 50: 5.0 mm | 70: 7.0 mm | 11: 11 mm | 12: 12 (outside dia. 17) mm |
| 35: 3.5 mm | 55: 5.3 mm, 5.5 mm | 75: 7.3 mm, 7.5 mm | 91: 12 (outside dia. 15) mm | 14: 14 mm |
| 45: 4.5 mm | 65: 6.5 mm | 80: 8.0 mm | 92: 12 (outside dia. 16) mm | 17: 17 mm |

ID./OD. code: (vinyl hose)

- | | | | | |
|-------------------------|--------------------------|---------------------------|---------------------------|---------------------------|
| 01: ID. 2.9, OD. 6.8 mm | 12: ID. 5.0, OD. 7.0 mm | 21: ID. 8.0, OD. 9.0 mm | 37: ID. 11.0, OD. 15.0 mm | 50: ID. 16.0, OD. 19.0 mm |
| 03: ID. 3.0, OD. 6.0 mm | 10: ID. 5.0, OD. 8.0 mm | 23: ID. 8.0, OD. 12.0 mm | 38: ID. 12.0, OD. 13.0 mm | 55: ID. 17.5, OD. 20.5 mm |
| 05: ID. 3.5, OD. 6.5 mm | 11: ID. 5.0, OD. 9.0 mm | 25: ID. 9.0, OD. 11.0 mm | 39: ID. 12.0, OD. 14.0 mm | 60: ID. 22.0, OD. 27.0 mm |
| 07: ID. 4.0, OD. 7.0 mm | 14: ID. 6.0, OD. 9.0 mm | 27: ID. 9.0, OD. 13.0 mm | 40: ID. 12.0, OD. 16.0 mm | |
| 08: ID. 4.5, OD. 6.5 mm | 17: ID. 7.0, OD. 9.0 mm | 33: ID. 10.0, OD. 14.0 mm | 43: ID. 13.0, OD. 15.0 mm | |
| 09: ID. 4.5, OD. 8.0 mm | 19: ID. 7.0, OD. 11.0 mm | 36: ID. 11.0, OD. 13.0 mm | 45: ID. 14.0, OD. 18.0 mm | |

Hose type:

- 1: Fuel hose
3: Vinyl hose
5: General hose

⊙ **CAUTION: It is DANGEROUS to confuse the fuel hose with the general purpose hose or vinyl hose.**

Never use a general purpose hose or vinyl hose in place of a fuel hose or vice versa. Always use the correct bulk part in the parts catalogue, according to the service manual or the instructions issued with the bulk part.

FLAT RATE SERVICE TIME

Flat rate service time (FRT) means the standard time required to service a product, which is listed in this manual to help the dealers control the actual working process and calculate the service charge by using it as a guide.

FRT setting system

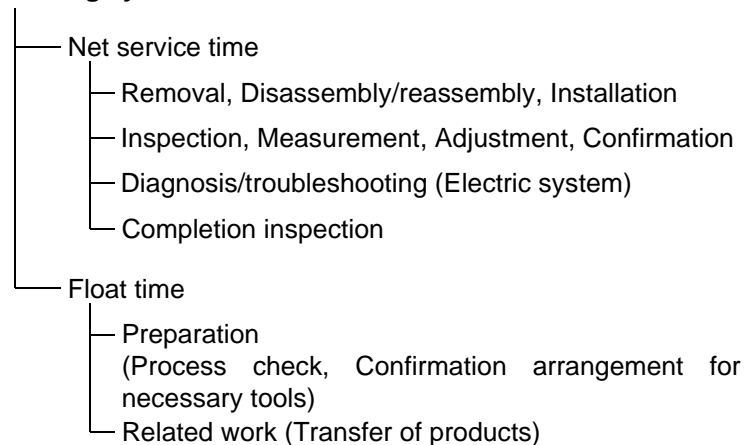

* Float time is set by multiplying the net service time by a given coefficient.

Editorial style

The service items shown in the text are listed with the exchange work time for the repair sales parts as the subject. Other representative service items not using repair parts (removal/installation, adjustment, inspection/measuring, and other work) are listed collectively in the list in the preface, classified according to the work.

FRT setting standard

- Decimal system (in unit of 0.1) is adopted to set FRT as it is convenient to calculate the wage.
Example: (0.1) → 6 minutes, (0.2) → 12 minutes
[Labor cost per hour] x [FRT] = [Wage]
- FRT is set with a hand tool.
- Service items and FRT can be subject to change depending on development of tools and service equipment and improvement in service procedure.

Work procedure

- As the work procedure is set with the work time according to the method in the separate Service Manual, refer to this Manual as required.
- Work methods permitting servicing in the shortest time still permitting assurance of safe work and product warranty are used for the setting of service items not listed in the Service Manual.
- Work basically is to be performed by one person, and when two or more people are required, setting is done as the total time for the number of people.
- The set value for the technological level of the workers uses a person with three years of experience in the repair of Honda products as the standard.
- Special tools and service equipment used to set FRT are those specified or recommended in Service Manual.

Service item whose FRT is not presented

- Accessories and service parts that are not listed to use in this manual.
 - Locations with little aging deterioration or breakage during normal use.
 - Service work that can be finished by one touch.
 - Service work that is seldom done (i.e. extremely small causes of trouble and service frequency).
 - Products and parts whose location for installation differs according to its status of use and application.
- * When FRT is not presented, please calculate wages based on appropriate actual work time.

Operation not included of FRT

- Oil and coolant water draining, Waiting time for warming up operation and etc..
- Additional operation that involves removal/installation of standard exterior equipment.
- Indirect time spent for service by visiting the customer, trade-in, and delivery.
- Indirect time required for ordering and delivery of parts.
- Cost for grease, adhesive agent, etc. used for service work.

**Explanation of FRT by using an example
(The example may differ from the actual presented items)**

Ref. No.	L.O.N.	(Relative ref. Number) Description	F.R.T.
①	1111L1	(1, 3, 4, 7) VALVE, INTAKE4.1	②
②		• NOTE: OHV type	③
③	1111L1A	• Includes: Engine removal and installation	④
		One head (intake all) add1.4	⑤

- ① Reference No. of the illustration of part that shows location of the replacement work.
- ② FRT is an abbreviation of Flat Rate Time indicating the standard service time required for the replacement.
- ③ LON is an abbreviation of Labor Operation Number, and it is a classification of the service items by the work unit code.

The same operation code is used regardless of the models.

Standard operation is indicated with 6 digits code, and additional operation is indicated with 7 digits code.

- ④ Indicating the intake valve replacement and FRT4.1.
- ⑤ Indicating FRT1.4 that will be added when additional operation (whole intake side of one cylinder head) is done in association with intake valve replacement.

- ⑥ Indicating work condition or application condition of the service item.
- ⑦ Indicating work contents that are included in the service item.
- ⑧ Indicating a reference No. whose operation and time are the same as FRT4.1 for the intake valve.

(The application range is limited to the service items without an LON setting within a same block.)

**How to refer to the service item by using the sample
(intake valve replacement)**

Open to the page of the block where the intake valve's spare part illustration is shown.

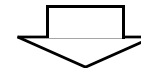

Look for the intake valve illustration, and refer to the service item and FRT that agree with the reference No.

Indication mark for the listing of service items that continues to the following page

Ref. No.	L.O.N.	(Relative ref. Number) Description	F.R.T.
2	1111L1	VALVE, INTAKE	4.1
	.	.	.
	.	.	.

+
Mark indicated at the last line.

Indication of the block with no setting of FRT

Ref. No.	L.O.N.	(Relative ref. Number) Description	F.R.T.
NO INFORMATION			

• LON code system

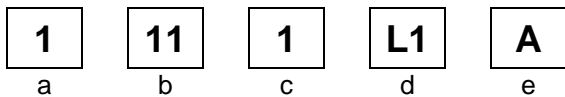

- a) Category code..... Engine
- b) Location/function code Engine upper
- c) Operation code..... Replace
- d) Operation sequence number (Unit code can be shown with alphabet)
..... Intake valve
(No regular rule of code)
- e) Additional code One head (intake all)
(No regular rule of code)

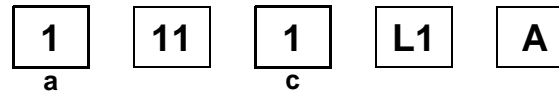

a) Category codes and classification

Code	Category
1	Engine
2	Power drive
3	Fuel & Exhaust
4	Frame & Body
5	Steering
6	Electrical
7	Axle & Brake
8	Control system
9	-
0	Attachments

c) Operation codes and classification

Code	Operation category
1	Replace, Removal/Installation, Change
2	Overhaul
3	Adjust, Rotation
4	(Paint-related work: Top-coat)
5	Test, Inspect/diagnose, Measurement
6	(Overhaul-related work: Rebore)
7	(Overhaul-related work: Reseal)
8	(Resurface)
9	(Paint-related work: Refinish)
0	Repair, Cleaning, Air bleeding

Major service items without using spare parts

(1) Removal/Installation, (2) Adjustment, (3) Inspection/
Measurement, (4) Overhaul, (5) Other work

E: Engine, T: Transmission, D: Drive system, B: Body and related
parts

(1) Removal/Installation

Set with the parts configuration in the status of being removed from
the product.

	LON	DESCRIPTION	FRT
E	1111L3	CYLINDER HEAD ASSEMBLY- REMOVAL/INSTALLATION	0.5

(2) Adjustment

	LON	DESCRIPTION	FRT
E	1113A1	VALVE CLEARANCE-ADJUSTMENT NOTE: For 1 product	0.3
	1163A0	CONTROL, THROTTLE/GOVERNOR- ADJUSTMENT	0.2
	3113A2	CARBURETOR IDLE-ADJUSTMENT	0.2

(3) Inspection, Measurement, Cleaning

	LON	DESCRIPTION	FRT
E	1105A0	ENGINE OIL-INSPECTION	0.1
	3120A0	AIR CLEANER-CLEANING INCLUDES: Air cleaner-inspection	0.1
	3130A0	SPARK ARRESTER-CLEANING	0.2
	6140A0	SPARK PLUG-ADJUSTMENT/CLEANING NOTE: For 1 product	0.2

(4) Overhaul

Work condition: The required Measurements, inspections,
adjustments, and cleaning/washing of each part are performed,
including the main body removal/installation work and the
replacement of defective parts.

	LON	DESCRIPTION	FRT
E	3112A0	CARBURETOR-OVERHAUL INCLUDES: All necessary adjustment	0.6

(5) Other work

	LON	DESCRIPTION	FRT
E	1101E1	ENGINE OIL-CHANGE INCLUDES: Engine oil-inspection	0.1

ENGINE GROUP

D 7

E-2

CYLINDER HEAD

E 1

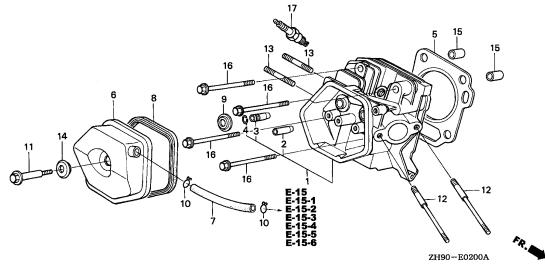

E-3

CYLINDER BARREL

E11

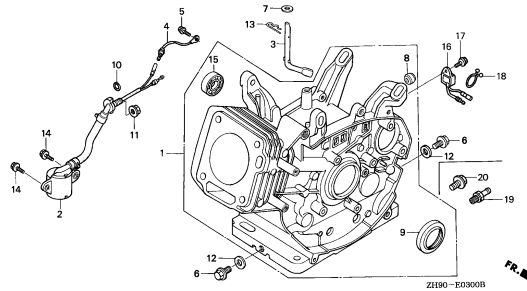

E-6

CRANKCASE COVER(1)

F 4

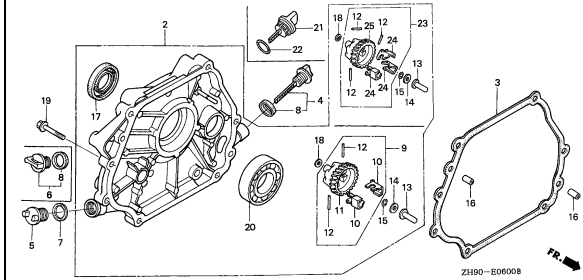

E-6-1

CRANKCASE COVER(2)

F16

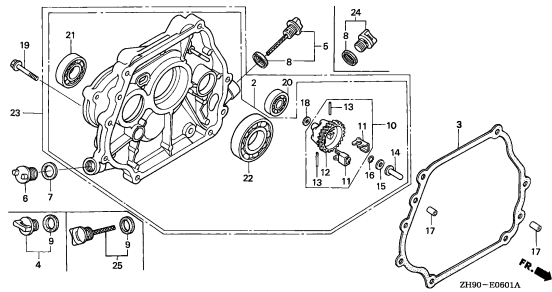

E-6-2

CRANKCASE COVER(3)

G 3

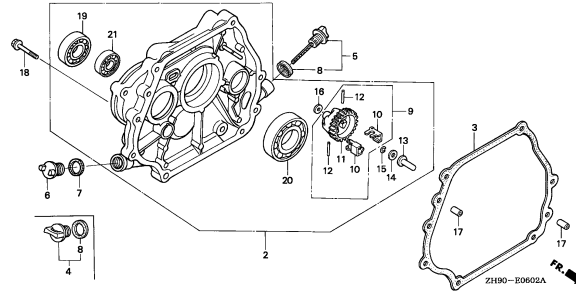

E-6-3

CRANKCASE COVER(4)

G 5

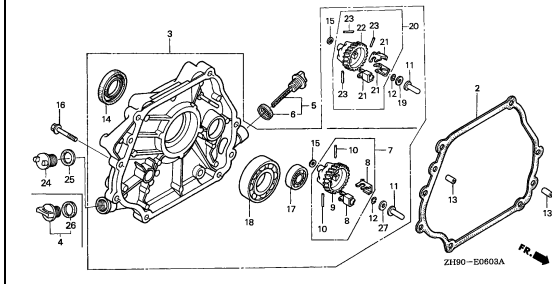

E-6-4

CRANKCASE COVER(5)

G 9

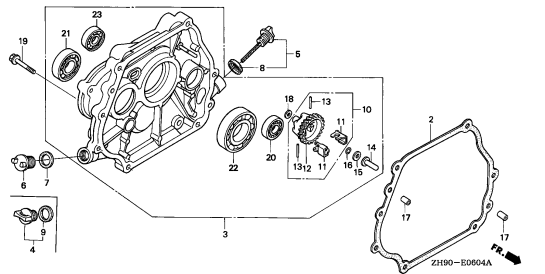

E-6-5

CRANKCASE COVER(6)

G11

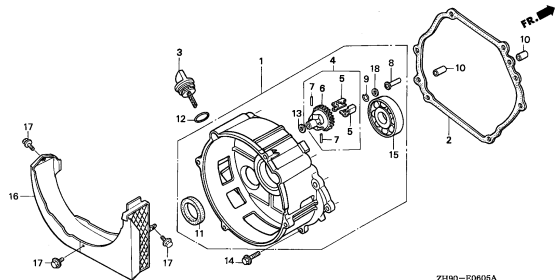

E-7

CRANKSHAFT

G12

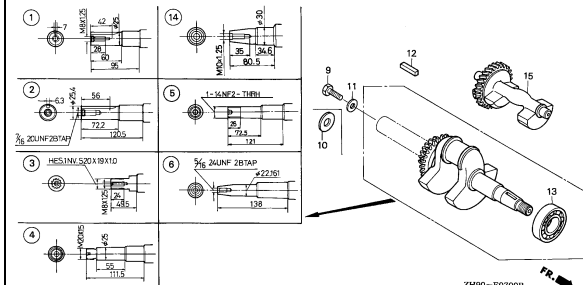

2

ENGINE GROUP

D 8

E-8

PISTON

G15

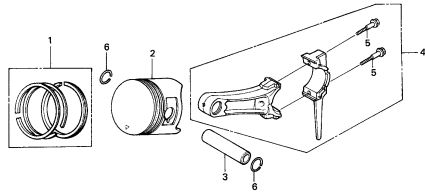

Z190-E0900A



E-9

CAMSHAFT

H 1

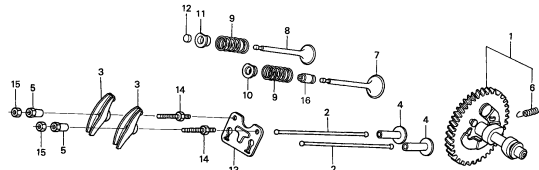

Z190-E0900A



E-11

RECOIL STARTER

H 5

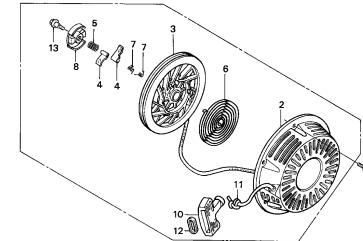

Z190-E1100B



E-12

FAN COVER

I 1

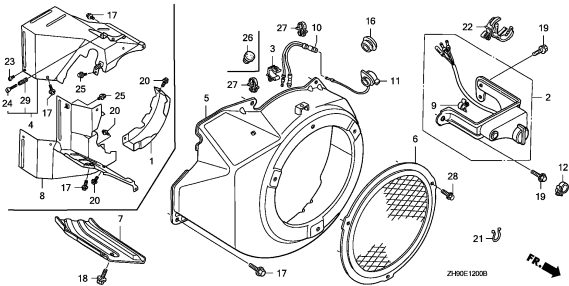

Z190E1200B



E-14

CARBURETOR(1)

I10

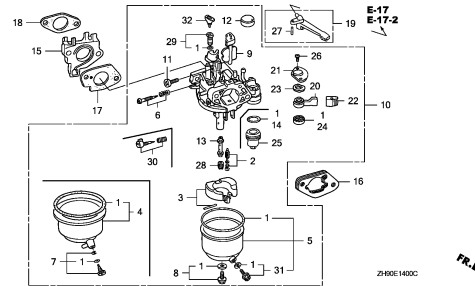

Z190E1400C



E-14-1

CARBURETOR(2)

K 6

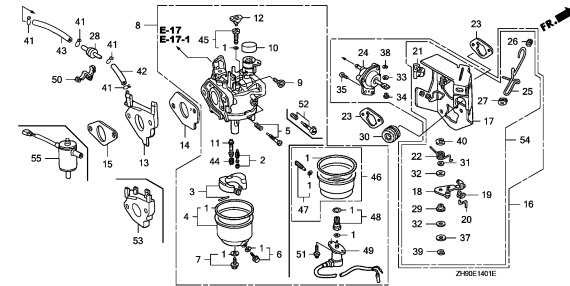

Z190E1401E



E-14-2

CARBURETOR(3)

K10

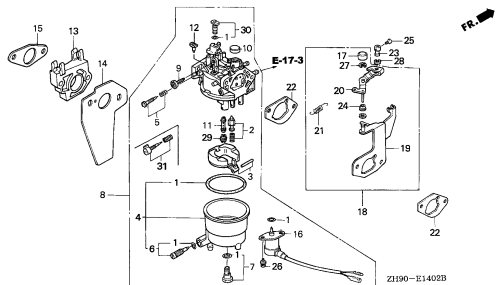

Z190-E1402B



E-14-3

CARBURETOR(4)

K12

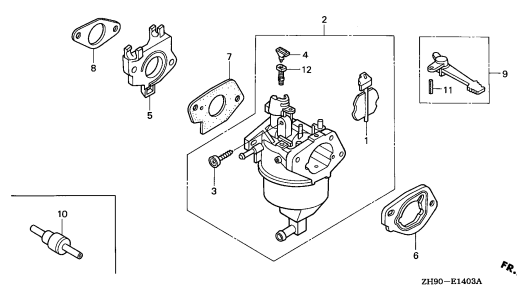

Z190-E1403A



E-15

AIR CLEANER(1)

K13

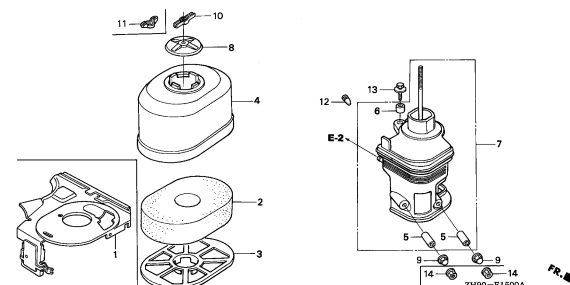

Z190-E1500A



2

ENGINE GROUP

D 9

E-15-1

AIR CLEANER(2)

K15

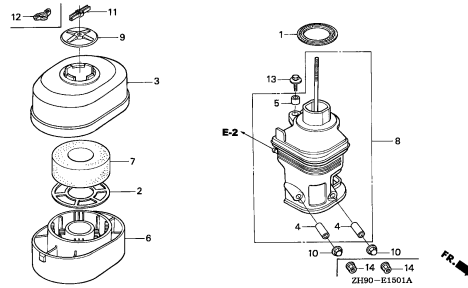

E-15-2

AIR CLEANER(3)

L 1

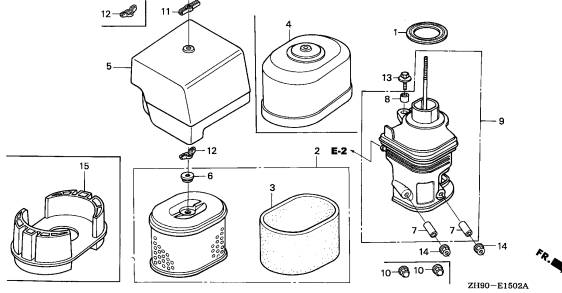

E-15-3

AIR CLEANER(4)

L11

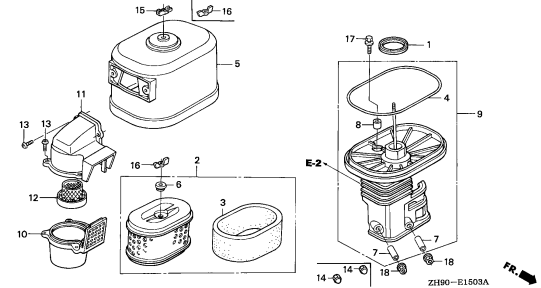

E-15-4

AIR CLEANER(5)

L13

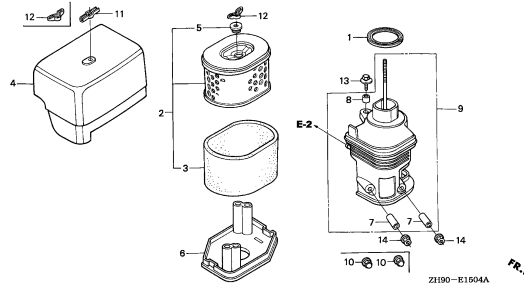

E-15-5

AIR CLEANER(6)

L15

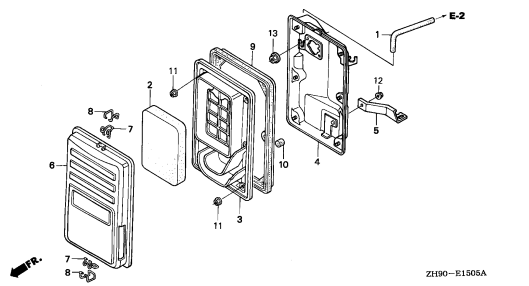

E-15-6

AIR CLEANER(7)

L16

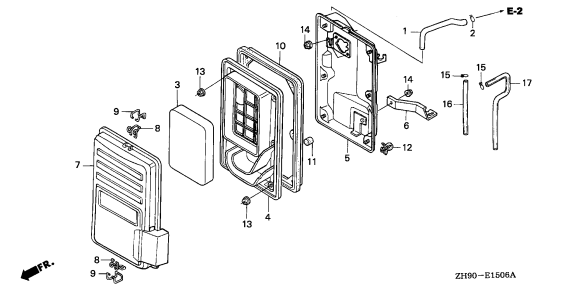

E-16

MUFFLER(1)

M 1

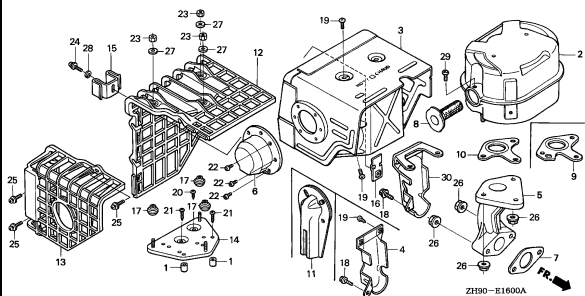

E-16-1

MUFFLER(2)

M 7

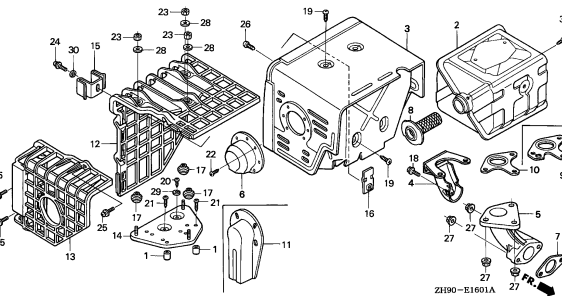

E-16-2

MUFFLER(3)

M15

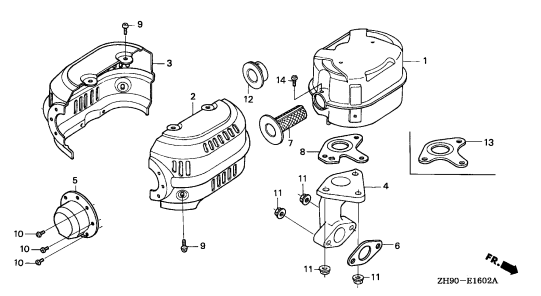

2

ENGINE GROUP

D10

E-16-3

MUFFLER(4)

N 1

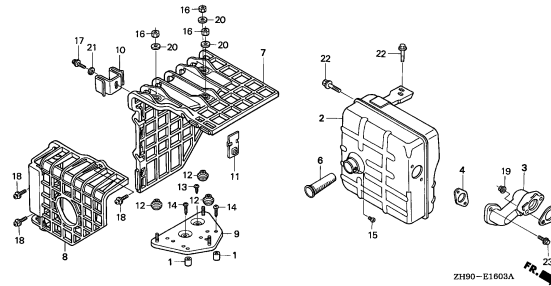

ZH90-E1603A

E-16-4

MUFFLER(5)

N 3

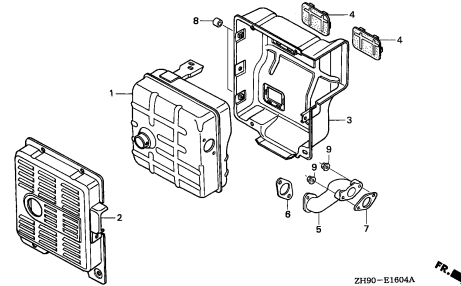

ZH90-E1604A

E-16-5

MUFFLER(6)

N 4

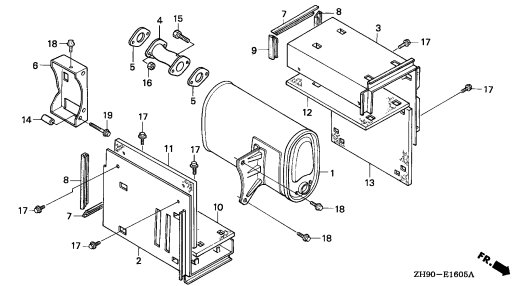

ZH90-E1605A

E-17

FUEL TANK(1)

N 5

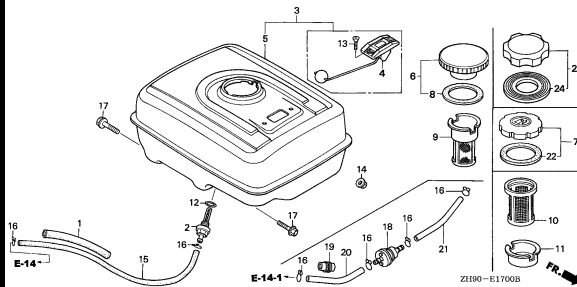

ZH90-E1700B

E-17-1

FUEL TANK(2)

2-B 1

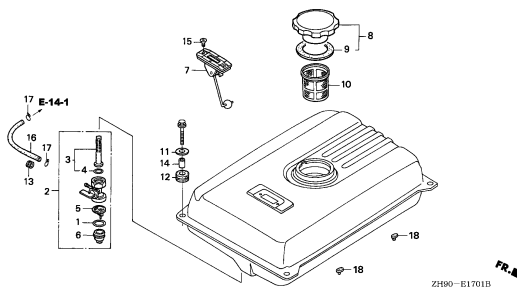

ZH90-E1701B

E-17-2

FUEL TANK(3)

2-B 2

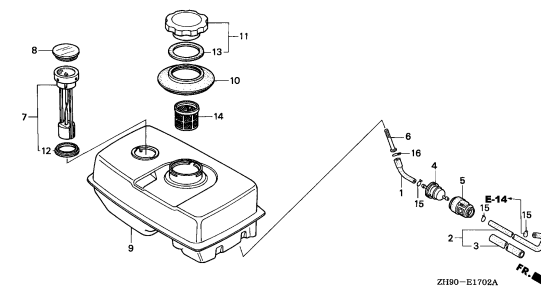

ZH90-E1702A

E-17-3

FUEL TANK(4)

2-B 3

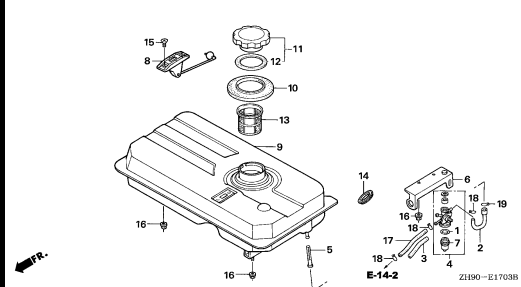

ZH90-E1703B

E-19

FLYWHEEL

2-B 4

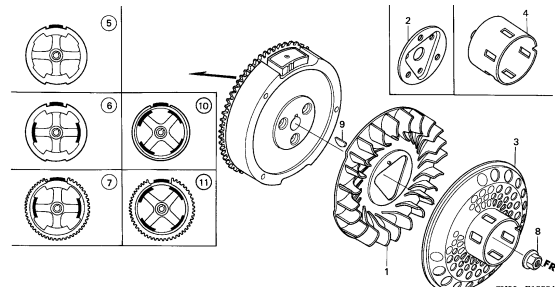

ZH90-E1900A

E-20

IGNITION COIL

2-B 7

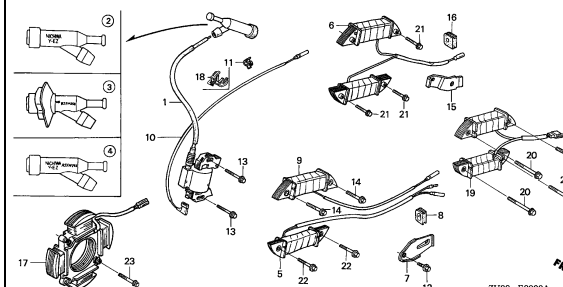

ZH90-E2000A

2

ENGINE GROUP

D11

E-21

STARTER MOTOR

2-B13

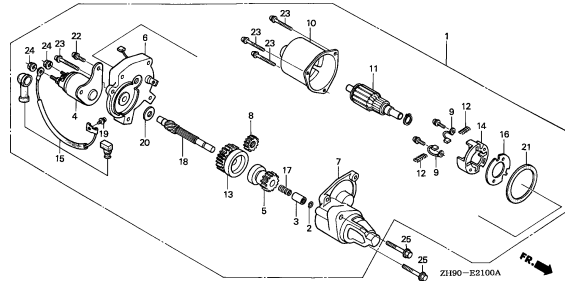

E-22

CONTROL(1)

2-C 5

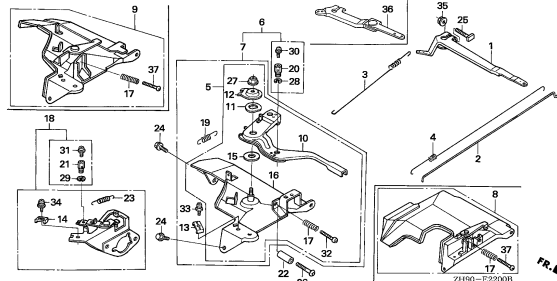

E-22-1

CONTROL(2)

2-D 5

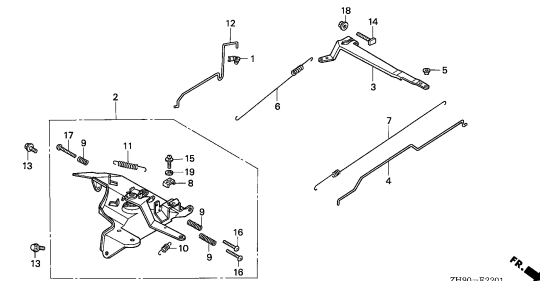

E-22-10

AUTO THROTTLE

2-D 6

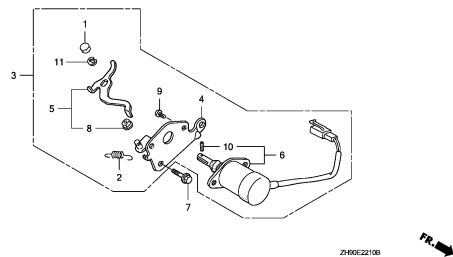

E-23

CONTROL BOX(1)

2-D 7

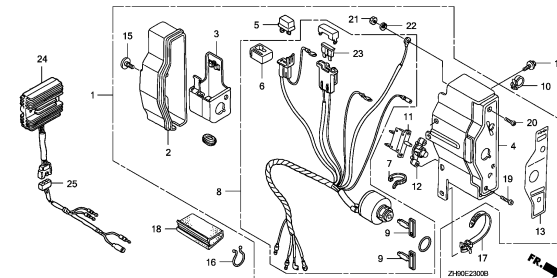

E-23-1

CONTROL BOX(2)

2-D 9

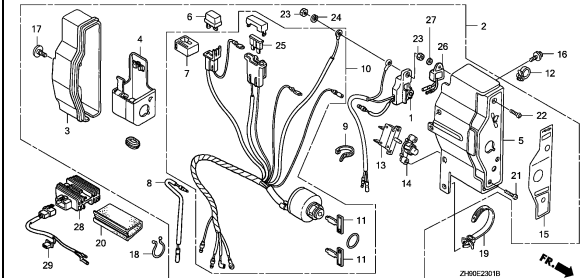

E-23-2

CONTROL BOX(3)

2-E 2

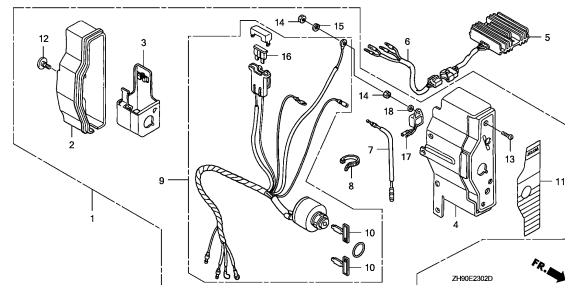

E-26

REDUCTION(1/2)(CLUTCH)

2-E 4

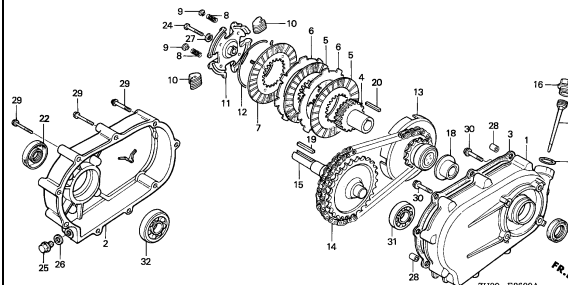

E-26-1

REDUCTION(1/2)

2-E 7

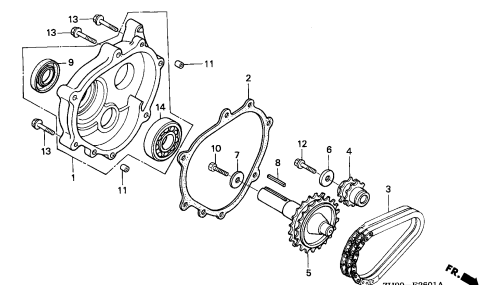

2

ENGINE GROUP

D12

E-26-2

REDUCTION(1/6)

2-E 9

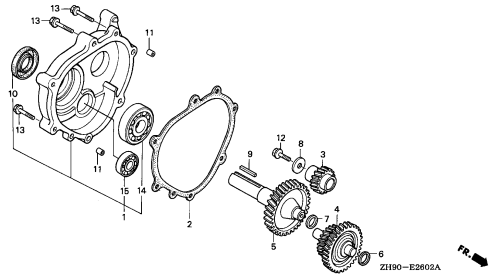

E-28

LABEL(1)

2-E11

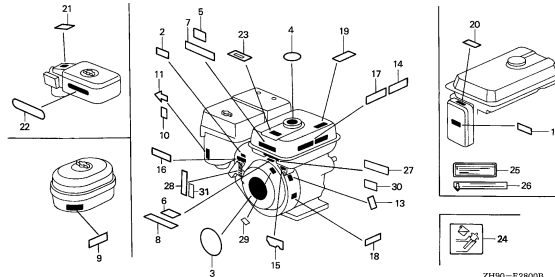

E-28-1

LABEL(2)

2-F 3

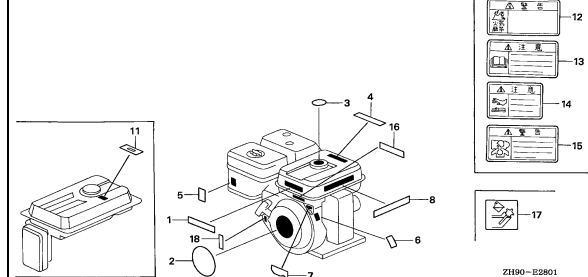

E-29

TOOL(1)

2-F 5

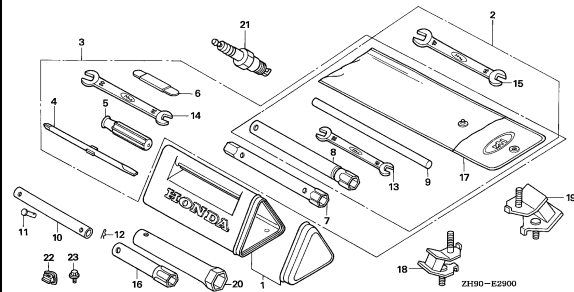

E-29-1

TOOL(2)

2-F 7

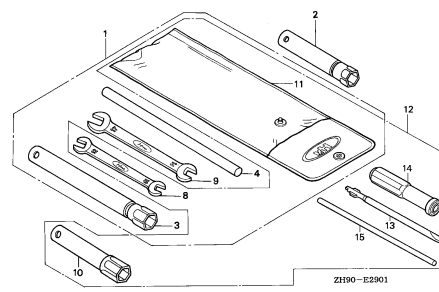

E-40

OTHER PARTS (FUEL TANK)

2-F 8

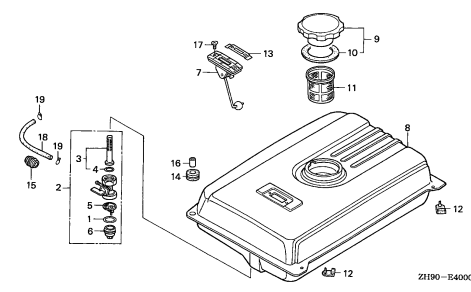

E-40-10

OTHER PARTS (EMERGENCY STOP SWITCH)

2-F 9

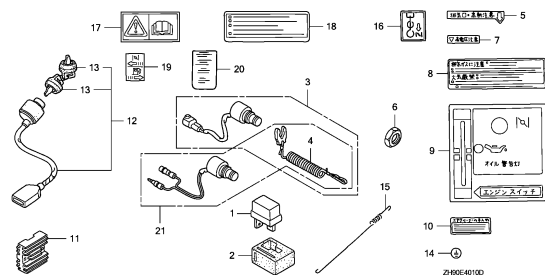

E-40-20

OTHER PARTS (KILL SWITCH/SUB HARNESS)

2-F11

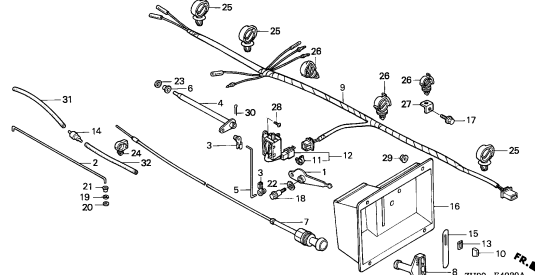

E-40-30

OTHER PARTS (UNDER FRAME)

2-F13

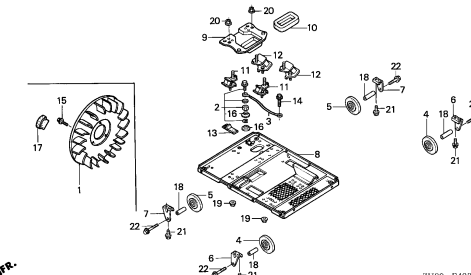

2

ENGINE GROUP

D13

EOP-1

GASKET KIT

2-F15

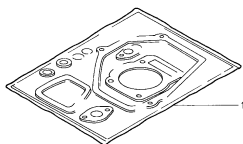

HENG-K0000

2

E-2

CYLINDER HEAD

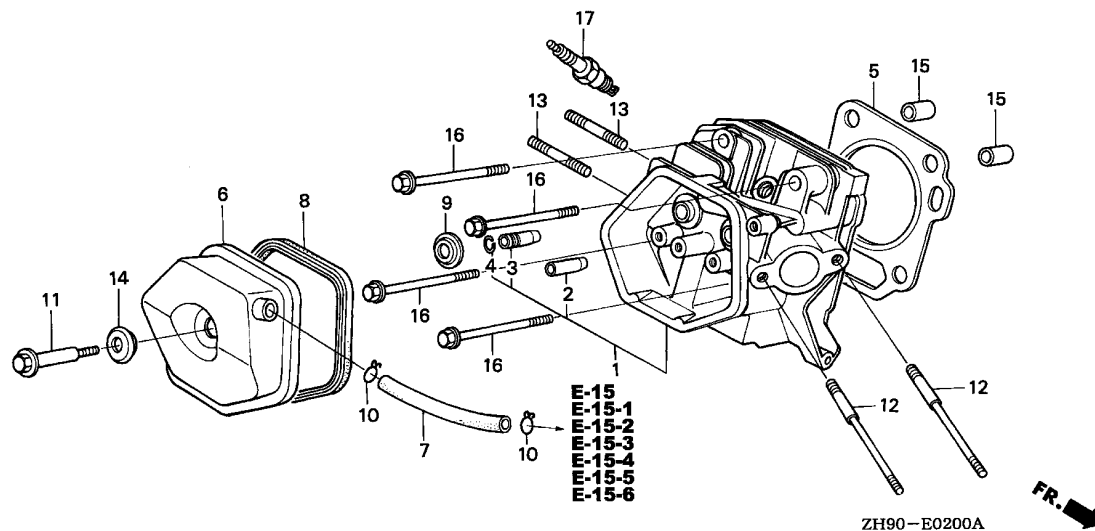

Ref. No.	L.O.N.	(Relative ref. Number) Description	F.R.T.
1	1111N3	HEAD, CYLINDERINCLUDES: Valve clearance adjustment and reface	0.9
2	1111E9	GUIDE, INTAKE VALVEINCLUDES: Valve clearance adjustment	0.8
	1111E9E	.Replace intake and exhaust all add	0.2
3	1111E8	GUIDE, EXHAUST VALVEINCLUDES: Valve clearance adjustment	0.8
	1111E8E	.Replace intake and exhaust all add	0.2
5	1111N4	GASKET, CYLINDER HEAD	0.5
7	1111K5	TUBE, BREATHER	0.2
8	1111D5	COVER, CYLINDER HEAD AND/OR PACKING, HEAD COVER	0.1
17	6141C1	PLUG, SPARKINCLUDES: Spark plug check	0.1

Ref. No.	Part No.	Description	Reqd. QTY			Serial No.	Parts catalogue code
			(1)	(2)	(3)		
1	12200-ZH9-000	HEAD COMP., CYLINDER	1	1	-	-----	ESS,ES1,ES3,HA,HAQ,HA2,HEA,HEA2,HEA8,HH,HX,HXQ4,HX26,HX8,LH,LHB1,LHB3,LHE,LHQ4,LJ,LJC,LJG,LSS,LT,LTJ,LW,LWD,LWD1,LX,LXE,LXE8,LXQ4,LXU,LXZ,LX16,L1,PA,PAE2,PA2,PX,PXE8,PXU,PX26,QA,QAB1,QAB3,QAE,QAE2,QAE6,QAG,QAG2,QAQ,QAQ4,QAR2,QAW,QA2,QD,QE,QH,QHC,QHE,QHE4,QHP1,QHQ4,QHR,QHR4,QHZ,QH26,QKE3,QL2,QME2,QMH,QP,QSC,QSC9,QSE,QSE8,QT,QWA2,QWA4,QWH2,QX,QXB,QXB6,QXB7,QXC,QXC4,QXC6,QXC9,QXE,QXEB,QXE4,QXE6,QXE8,QXQ4,QXU,QX26,Q1,Q2,RA,RA2,RD,RH,RHE,RHE4,RHQ4,RH26,RSC2,RSS,RX,RXQ4,RXU,R1,SD,SE,SH,SHE,SHEZ,SHQ4,SJ,SJG,SJP,SK,SKE1,SMC4,SMD,SME1,SME6,SMX2,SN,SW,SWC4,SWE,SX,SXB,SXB7,SXE,SXEB,SXE4,SXE8,SXQ4,SXU,SX2,S1,VA,VAG2,VAW,VAW1,VA2,VDE,VDE2,VD16,VEB6,VH,VKB2,VKE4,VKX4,VME2,VMS2,VMT,VMX2,VM2,VNG1,VNT2,VN17,VPE4,VPE5,VPE7,VPX4,VPX5,VPX7,VSD,VSD3,VSD7,VSH7,VS37,VWA,VWA2,VWN2,VMT4,VW12,VW22,VX,VXB,VXB2,VXB6,VXB7,VXE,VXEB,VXE4,VXE6,VXE7,VXG,VXQ4,VXTB,VXT1,VXU,VXU1,VX26,V1,WMT8,WXE8,W1
	12200-ZH9-800	-	-	1	-----	HAP,RXP,VXP,VXQP

Ref. No.	Part No.	Description	Reqd. QTY			Serial No.	Parts catalogue code
			(1)	(2)	(3)		
(1)	12200-ZH9-405	HEAD COMP., CYLINDER	1	1	-	-----	ESS/A,ES1/A,ES3/A,HA2/A,HEA2/A,HEA8/A,HX/A,HXQ4/A,HX26/A,HX8/A,LH/A,LHB5,LHE/A,LJ/A,LJC/A,LJG/A,LT/A,LW/A,LWD1/A,LX/A,LXE/A,LXE8/A,LXQ4/A,LXU/A,L1/A,PAE2/A,PA2/A,PX/A,PXE8/A,PXU/A,PX26/A,QAB3/A,QAE2/A,QAE6/A,QAG/A,QAG2/A,QAQ4/A,QAR2/A,QAW/A,QA2/A,QD/A,QE/A,QH/A,QHB5,QHE4/A,QHP1/A,QHQ4/A,QHR/A,QHR4/A,QHZ/A,QH26/A,QKE3/A,QKE4,QME2/A,QMH/A,QP/A,QSC9/A,QSE/A,QSE2,QSE8/A,QT/A,QWA4/A,QWH2/A,QX/A,QXB/A,QXB6/A,QXB7/A,QXC4/A,QXC6/A,QXC9/A,QXE/A,QXE4/A,QXE6/A,QXE8/A,QXQ4/A,QXU/A,QX26/A,Q1/A,RA2/A,RD/A,RHE4/A,RHQ4/A,RH26/A,RSC2/A,RSS/A,RX/A,RXQ4/A,RXU/A,R1/A,SD/A,SE/A,SH/A,SHQ4/A,SJ/A,SJG/A,SMC4/A,SME1/A,SME6/A,SN/A,SWA4,SWC4/A,SN/A,SXB/A,SXB7/A,SXE/A,SXEB/A,SXE4/A,SXE8/A,SXQ4/A,SXU/A,S1/A,VAG2/A,VA2/A,VDE2/A,VKB2/A,VMA4,VME2/A,VME4,VMT/A,VM2/A,VNG1/A,VNT2/A,VN17/A,VPE4/A,VPE7/A,VPX4/A,VPX7/A,VSD/A,VSD3/A,VSD7/A,VS3,VS37/A,VWA2/A,VWN2/A,VWT4/A,VW12/A,VX/A,VXB/A,VXB7/A,VXEB/A,VXE4/A,VXE6/A,VXE7/A,VXQ4/A,VXT1/A,VXU/A,VXU1/A,WMA4,WMT8/A,WXE8/A,W1/A,HAP/A,RXP/A,VXP/A
	12200-ZH9-406	-	-	1	-----	
2	12204-ZE2-306	GUIDE, IN. VALVE (O.S.)	(1)	(1)	(1)		
3	12205-ZE2-305	GUIDE, EX. VALVE (O.S.)	(1)	(1)	(1)		
4	12216-ZE2-300	CLIP, VALVE GUIDE	1	1	1		
5	12251-ZH9-000	GASKET, CYLINDER HEAD	1	1	1		
6	12310-ZE2-010	COVER COMP., HEAD	1	(1)	-	-----	1046250 HA,HH,HX,LH,LHE,LJ,LW,LWD,LX,LXZ,L1,PA,PX,QA,QAE,QD,QE,QH,QHE,QP,QX,QXB,QXE,QXEB,Q1,Q2,RA,RD,RH,RHE,RX,R1,SD,SE,SH,SHE,SHE2,SJ,SJP,SK,SW,SWE,SX,SXB,SXE,SXEB,S1,VA,VAW,VH,VNG1,VSD,VSD3,VX,VXB,VXE,VXEB,V1,W1
	12310-ZE2-020	1	(1)	-	-----	ES1,ES1/A,ES3,ES3/A,HA2,HA2/A,HEA,HEA2,HEA2/A,HEA8,HEA8/A,HX/A,HXQ4,HXQ4/A,HX26,HX26/A,HX8,HX8/A,LH/A,LHB1,LHB3,LHB5,LHE/A,LHQ4,LJ/A,LJC,LJC/A,LJG,LJG/A,LSS,LT,LT/A,LTJ,LW/A,LWD1,LWD1/A,LX/A,LXE,LXE/A,LXE8,LXE8/A,LXQ4,LXQ4/A,LXU,LXU/A,LX16,L1/A,PAE2,PAE2/A,PA2,PA2/A,PX/A,PXE8,PXE8/A,PXU,PXU/A,PX26,PX26/A,QAB1,QAB3,QAB3/A,QAE2,QAE2/A,QAE6,QAE6/A,QAG,QAG/A,QAG2,QAG2/A,QAQ4,QAQ4/A,QAR2,QAR2/A,QAW,QAW/A,QA2,QA2/A,QD/A,QE/A,QH/A,QHB5,QHE4,QHE4/A,QHP1,QHP1/A,QHQ4,QHQ4/A,QHR,QHR/A,QHR4,QHR4/A,QHZ,QHZ/A,QH26,QH26/A,QKE3,QKE3/A,QKE4,QL2,QME2,QME2/A,QMH,QMH/A,QP/A,QSE,QSE/A,QSE2,QSE8,QSE8/A,QT,QT/A,QX/A,QXB/A,QXB6,QXB6/A,QXB7,QXB7/A,QXE/A,QXE4,QXE4/A,QXE6,QXE6/A,QXE8,QXE8/A,QXQ4,QXQ4/A,QXU,QXU/A,QX26,QX26/A,Q1/A,RA2,RA2/A,RD/A,RHE4,RHE4/A,RHQ4,RHQ4/A,RH26,RH26/A,RSC2,RSC2/A,RSS,RSS/A,RX/A,RXQ4,RXQ4/A,RXU,RXU/A,R1/A,SD/A,SE/A,SH/A,SHQ4,SHQ4/A,SJ/A,SJG,SJG/A,SKE1,SMC4,SMC4/A,SMD,SME1,SME1/A,SME6,SME6/A,SMX2,SN,SN/A,SWA4,SWC4,SWC4/A,SX/A,SXB/A,SXB7/A,SXE/A,SXEB/A,SXE4,SXE4/A,SXE8,SXE8/A,SXQ4,SXQ4/A,SXU,SXU/A,SX2,S1/A,VAG2,VAG2/A,VAW1,VA2,VA2/A,VDE,VDE2,VDE2/A,VD16,VEB6,VKB2,VKB2/A,VKE4,VKX4,VME2,VME2/A,VMS2,VMT,VMT/A,VMX2,VM2,VM2/A,VNG1/A,VNT2,VNT2/A,VN17,VN17/A,VPE4,VPE4/A,VPE5,VPE7,VPE7/A,VPX4,VPX4/A,VPX5,VPX7,VPX7/A,VSD/A,VSD3/A,VSD7,VSD7/A,VSH7,VS3,VS37,VS37/A,VWA,VWA2,VWA2/A,VWN2,VWN2/A,VWT4,VWT4/A,VW12,VW12/A,VW22,VX/A,VXB/A,VXB2,VXB6,VXB7,VXB7/A,VXEB/A,VXE4,VXE4/A,VXE6,VXE6/A,VXE7,VXE7/A,VXG,VXQ4,VXQ4/A,VXTB,VXT1,VXT1/A,VXU,VXU/A,VXU1,VXU1/A,VX26,WMA4,WMT8,WMT8/A,WXE8,WXE8/A,W1/A
			1	(1)	-	-----	1046251 HA,HH,HX,LH,LHE,LJ,LW,LWD,LX,LXZ,L1,PA,PX,QA,QAE,QD,QE,QH,QHE,QP,QX,QXB,QXE,QXEB,Q1,Q2,RA,RD,RH,RHE,RX,R1,SD,SE,SH,SHE,SHE2,SJ,SJP,SK,SW,SWE,SX,SXB,SXE,SXEB,S1,VA,VAW,VH,VNG1,VSD,VSD3,VX,VXB,VXE,VXEB,V1,W1
			-	-	1		
	12310-ZE3-790	COVER COMP., HEAD (BRETHER TUBE JOINT)	1	(1)	-	-----	1041913 HAQ,L1,QAQ,QHC,QXC,Q1,Q2,R1,S1,V1,W1



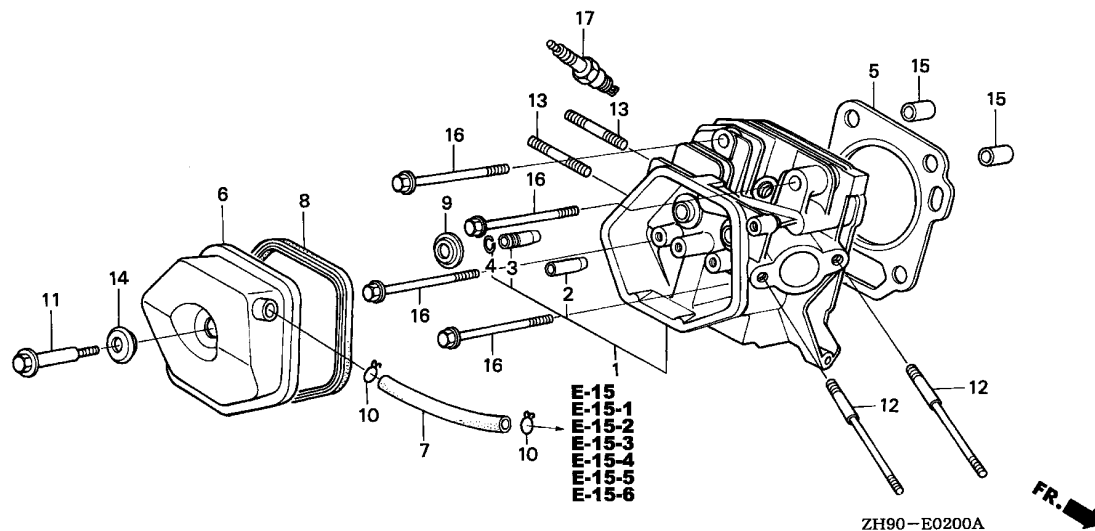

Ref. No.	Part No.	Description	Reqd. QTY			Serial No.	Parts catalogue code
			(1)	(2)	(3)		
(6)	12310-ZE3-791	COVER COMP., HEAD (BRETHER TUBE JOINT)	1	(1)	-	-----	ESS,ESS/A,L1/A,QSC,QSC9,QSC9/A,QWA2,QWA4,QWA4/A,QWH2,QWH2/A,QXC4 QXC4/A,QXC6,QXC6/A,QXC9,QXC9/A,Q1/A,R1/A,S1/A,VMA4,VME4,W1/A
7	12315-ZE3-840	TUBE, BREATHER	1	(1)	-	1041914	HAQ,L1,QAQ,QHC,QXC,Q1,Q2,R1,S1,V1,W1
	95005-11105-30	TUBE, 11X105(95005-11001-30M)	-	(1)	-	-----	HAQ,QAQ,QHC,QSC,QSC9,QSC9/A,QWA2,QWA4,QWA4/A,QWH2,QWH2/A,QXC,QXC4 QXC4/A,QXC6,QXC6/A,QXC9,QXC9/A,VMA4,VME4
			1	(1)	-	1174910	HA,HA2,HEA,HEA2,HH,HX,HXQ4,HX26,LH,LHE,LHQ4,LJ,LJG,LSS,LTJ,LW,LX LXE,LXQ4,LXZ,LX16,L1,PA,PA2,PX,PX26,QA,QAE,QAE2,QAE6,QAQ4,QAR2 QA2,QD,QE,QH,QHE,QHE4,QHQ4,QH26,QME2,QP,QT,QX,QXB,QXE,QXEB,QXE4 QXE6,QXQ4,QX26,Q1,RA,RA2,RD,RH,RHE,RHE4,RHQ4,RH26,RSC2,RX,RXQ4,R1 SD,SE,SH,SHE,SHEZ,SHQ4,SJ,SJG,SJP,SK,SMC4,SME1,SME6,SN,SW,SWE,SX SXB,SXE,SXEB,SXE4,SXQ4,SX2,S1,VA,VAW,VAW1,VA2,VDE,VD16,VEB6,VH VNG1,VSD,VSD3,VVA,VWA2,VWN2,VW12,VW22,VX,VXB,VXB2,VXB6,VXE,VXEB VXE4,VXG,VXQ4,VXU,VX26,V1,W1
			1	-	-	1054062	LWD
			-	(1)	-	-----	Q2
			-	-	1	1000009	VXP,VXQP
	15721-ZE2-780	TUBE, BREATHER	1	-	-	1054063	LWD

Ref. No.	Part No.	Description	Reqd. QTY			Serial No.	Parts catalogue code	
			(1)	(2)	(3)			
(7)	95005-11100-30	TUBE, 11X100(95005-11001-30M)	1	(1)	1	-----	ES1,ES1/A,HAP,HAP/A,HA2/A,HEA2/A,HEA8,HEA8/A,HX/A,HXQ4/A,HX26/A,HX8,HX8/A,LH/A,LHB1,LHB3,LHB5,LHE/A,LJ/A,LJC,LJC/A,LJG/A,LT,LT/A,LW/A,LWD1,LWD1/A,LX/A,LXE/A,LXE8,LXE8/A,LXQ4/A,LXU,LXU/A,L1/A,PAE2,PAE2/A,PA2/A,PX/A,PXE8,PXE8/A,PXU,PXU/A,PX26/A,QAB1,QAB3,QAB3/A,QAE2/A,QAE6/A,QAG,QAG/A,QAG2,QAG2/A,QAQ4/A,QAR2/A,QAW,QAW/A,QA2/A,QD/A,QE/A,QH/A,QHB5,QHE4/A,QHP1,QHP1/A,QHQ4/A,QHR,QHR/A,QHR4,QHR4/A,QHZ,QHZ/A,QH26/A,QKE3,QKE3/A,QKE4,QL2,QME2/A,QMH,QMH/A,QP/A,QSE,QSE/A,QSE2,QSE8,QSE8/A,QT/A,QX/A,QXB/A,QXB6,QXB6/A,QXB7,QXB7/A,QXE/A,QXE4/A,QXE6/A,QXE8,QXE8/A,QXQ4/A,QXU,QXU/A,QX26/A,Q1/A,RA2/A,RD/A,RHE4/A,RHQ4/A,RH26/A,RSC2/A,RSS,RSS/A,RX/A,RXP,RXP/A,RXQ4/A,RXU,RXU/A,R1/A,SD/A,SE/A,SH/A,SHQ4/A,SJ/A,SJG/A,SKE1,SMC4/A,SMD,SME1/A,SME6/A,SMX2,SN/A,SWA4,SWC4,SWC4/A,SX/A,SXB/A,SXB7,SXB7/A,SXE/A,SXEB/A,SXE4/A,SXE8,SXE8/A,SXQ4/A,SXU,SXU/A,S1/A,VAG2,VAG2/A,VA2/A,VDE2,VDE2/A,VKB2,VKB2/A,VME2,VME2/A,VM2,VM2/A,VNG1/A,VNT2,VNT2/A,VN17,VN17/A,VSD/A,VSD7,VSD7/A,VSH7,VS37,VWA2/A,VWN2/A,VWT4,VWT4/A,VW12/A,VX/A,VXB/A,VXB7,VXB7/A,VXEB/A,VXE4/A,VXE6,VXE6/A,VXE7,VXE7/A,VXP/A,VXQ4/A,VXTB,VXT1,VXT1/A,VXU/A,VXU1,VXU1/A,WMA4,WMT8,WMT8/A,WXE8,WXE8/A,W1/A,HA,HA2,HEA,HEA2,HH,HX,HXQ4,HX26,LH,LHE,LHQ4,LJ,LJG,LSS,LTJ,LW,LX,LXE,LXQ4,LXZ,LX16,L1,PA,PA2,PX,PX26,QA,QAE,QAE2,QAQ4,QAR2,QA2,QD,QE,QH,QHE,QHE4,QHQ4,QH26,QME2,QP,QT,QX,QXB,QXE,QXEB,QXE4,QXE6,QXQ4,QX26,Q1,RA,RA2,RD,RH,RHE,RHE4,RHQ4,RH26,RSC2,RX,RXQ4,R1,SD,SE,SH,SHE,SHEZ,SHQ4,SJ,SJG,SJP,SK,SMC4,SME1,SME6,SN,SW,SWE,SX,SXB,SXE,SXEB,SXE4,SXQ4,SX2,S1,VA,VAW,VAW1,VA2,VDE,VD16,VEB6,VH,VNG1,VSD,VSD3,VWA,VWA2,VWN2,VW12,VW22,VX,VXB,VXB2,VXB6,VXE,VXEB,VXE4,VXG,VXQ4,VXU,VX26,V1,W1	
			1	(1)	-	1174911	-----	VXP,VXQP
	8 12391-ZE2-020	PACKING, HEAD COVER	1	(1)	1	1000010	-----	
	9 14775-ZE2-010	SEAT, VALVE SPRING	1	1	1			
	10 17316-611-000	CLIP, BREATHER TUBE	2	-	-	-----	-----	HAQ,QAQ,QHC,QSC,QSC9,QSC9/A,QWA2,QWA4,QWA4/A,QWH2,QWH2/A,QXC,QXC4,QXC4/A,QXC6,QXC6/A,QXC9,QXC9/A,VMA4,VME4
			-	(2)	-			
	11 90014-ZE2-000	BOLT, HEAD COVER	1	1	1			
	12 90042-ZB7-000	BOLT, STUD, 8X111	2	-	-	-----	-----	ESS,ESS/A



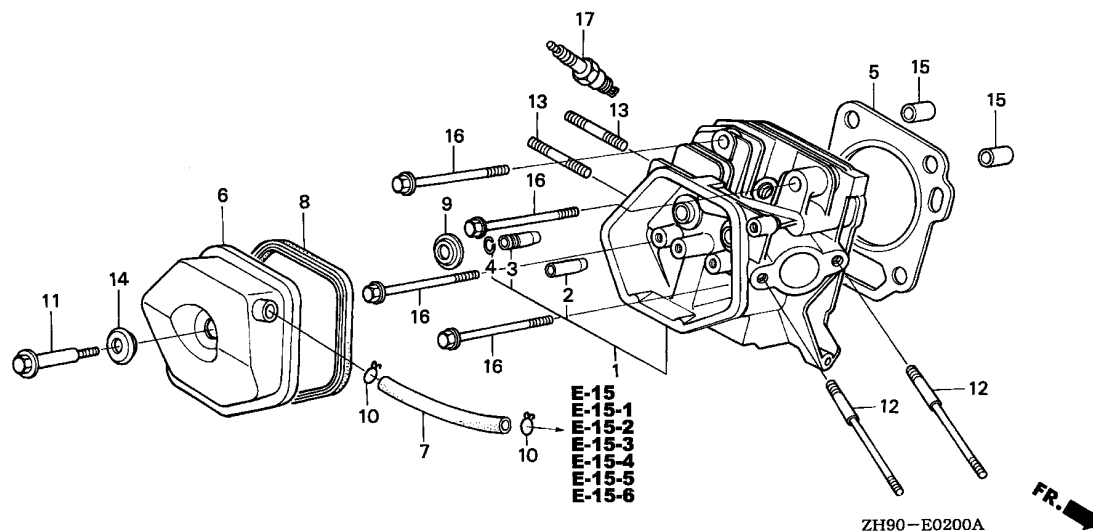

Ref. No.	Part No.	Description	Reqd. QTY			Serial No.	Parts catalogue code
			(1)	(2)	(3)		
12)	90042-ZE2-000	BOLT, STUD, 8X123	2	-	-	-----	ES1,ES1/A,HA,HAQ,HA2,HA2/A,HEA,HEA2,HEA2/A,HEA8,HEA8/A,HH,HX,HX/A,HXQ4,HXQ4/A,HX26,HX26/A,HX8,HX8/A,LH,LH/A,LHB1,LHB3,LHB5,LHE,LHE/A,LHQ4,LJ,LJ/A,LJC,LJC/A,LJG,LJG/A,LSS,LT,LT/A,LTJ,LW,LW/A,LWD,LWD1,LWD1/A,LX,LX/A,LXE,LXE/A,LXE8,LXE8/A,LXQ4,LXQ4/A,LXU,LXU/A,LXZ,LX16,PA,PAE2,PAE2/A,PA2,PA2/A,PX,PX/A,PXE8,PXE8/A,PXU,PXU/A,PX26,PX26/A,QA,QAB1,QAB3,QAB3/A,QAE,QAE2,QAE2/A,QAE6,QAE6/A,QAG,QAG/A,QAG2,QAG2/A,QAQ,QAQ4,QAQ4/A,QAR2,QAR2/A,QAW,QAW/A,QA2,QA2/A,QD,QD/A,QE,QE/A,QH,QH/A,QHB5,QHC,QHE,QHE4,QHE4/A,QHP1,QHP1/A,QHQ4,QHQ4/A,QHR,QHR/A,QHR4,QHR4/A,QHZ,QHZ/A,QH26,QH26/A,QKE3,QKE3/A,QKE4,QL2,QME2,QME2/A,QMH,QMH/A,QP,QP/A,QSC,QSC9,QSC9/A,QSE,QSE/A,QSE2,QSE8,QSE8/A,QT,QT/A,QWA2,QWA4,QWA4/A,QWH2,QWH2/A,QX,QX/A,QXB,QXB/A,QXB6,QXB6/A,QXB7,QXB7/A,QXC,QXC4,QXC4/A,QXC6,QXC6/A,QXC9,QXC9/A,QXE,QXE/A,QXEB,QXE4,QXE4/A,QXE6,QXE6/A,QXE8,QXE8/A,QXQ4,QXQ4/A,QXU,QXU/A,QX26,QX26/A,RA,RA2,RA2/A,RD,RD/A,RH,RHE,RHE4,RHE4/A,RHQ4,RHQ4/A,RH26,RH26/A,RSC2,RSC2/A,RSS,RSS/A,RX,RX/A,RXQ4,RXQ4/A,RXU,RXU/A,SD,SD/A,SE,SE/A,SH,SH/A,SHE,SHEZ,SHQ4,SHQ4/A,SJ,SJ/A,SJG,SJG/A,SJP,SK,SKE1,SMC4,SMC4/A,SMD,SME1,SME1/A,SME6,SME6/A,SMX2,SN,SN/A,SW,SWA4,SWC4,SWC4/A,SWE,SX,SX/A,SXB,SXB/A,SXB7,SXB7/A,SXE,SXE/A,SXEB,SXEB/A,SXE4,SXE4/A,SXE8,SXE8/A,SXQ4,SXQ4/A,SXU,SXU/A,SX2,VA,VAG2,VAG2/A,VAW,VAW1,VA2,VA2/A,VDE,VDE2,VDE2/A,VD16,VEB6,VH,VKB2,VKB2/A,VMA4,VME2,VME2/A,VME4,VM2,VM2/A,VNG1,VNG1/A,VNT2,VNT2/A,VN17,VN17/A,VSD,VSD/A,VSD7,VSD7/A,VSH7,VWA,VWA2,VWA2/A,VWN2,VWN2/A,VWT4,VWT4/A,VW12,VW12/A,VW22,VX,VX/A,VXB,VXB/A,VXB2,VXB6,VXB7,VXB7/A,VXE,VXE6,VXE6/A,VXE4,VXE4/A,VXE7,VXE7/A,VXG,VXG4,VXQ4/VXTB,VXT1,VXT1/A,VXU,VXU/A,VXU1,VXU1/A,VX26,WMA4,WMT8,WMT8/A,WXE8,WXE8/A
	90042-ZE2-700	BOLT, STUD, 8X98	2	2	-	-----	ES3,ES3/A,VKE4,VKX4,VMS2,VMT,VMT/A,VMX2,VPE4,VPE4/A,VPE5,VPE7,VPE7/A,VPX4,VPX4/A,VPX5,VPX7,VPX7/A,VSD3,VSD3/A,VS3,VS37,VS37/A

Ref. No.	Part No.	Description	Reqd. QTY			Serial No.	Parts catalogue code
			(1)	(2)	(3)		
13	90012-KM9-000	BOLT, STUD, 8X34	2	-	-	-----	ESS,ESS/A,SJP
	90018-ZK6-P10	BOLT, STUD, 8X22	2	-	-	-----	VPE5,VPX5
	90047-ZE2-000	BOLT, STUD, 8X47	2	2	-	-----	HA,HAQ,HEA,HH,LHB1,LHB3,LHQ4,LXZ,PA,QA,QAB1,QAE,QAQ,QHC,QHE,QSC,QXC,QXEB,Q2,RA,RHE,SHE,SHEZ,SK,SWE,SX2,VA,VAW,VAW1,VEB6,VWA,VXB6
			2	2	-	1457779	V1 ES1,ES3,HA2,HEA2,HEA8,HX,HXQ4,HX26,HX8,LH,LHE,LJ,LJC,LJG,LSS,LTJ,LW,LWD,LX,LXE,LXE8,LXQ4,LXU,LX16,L1,PAE2,PA2,PX,PXU,PX26,QAB3,QAE2,QAE6,QAQ4,QAR2,QA2,QD,QE,QH,QHE4,QHP1,QHQ4,QHZ,QH26,QKE3,QME2,QMH,QP,QSC9,QSE,QSE8,QT,QX,QXB,QXB6,QXC4,QXC6,QXC9,QXE,QXE4,QXE6,QXE8,QXQ4,QXU,QX26,Q1,RA2,RD,RH,RHE4,RHQ4,RH26,RSC2,RX,RXQ4,RXU,R1,SD,SE,SH,SHQ4,SJ,SJG,SKE1,SMC4,SMD,SME1,SME6,SN,SW,SWC4,SX,SXB,SXE,SXEB,SXE4,SXE8,SXQ4,SXU,S1,VA2,VDE,VDE2,VD16,VH,VKB2,VME2,VM2,VNG1,VNT2,VPE4,VPX4,VSD,VSD3,VWA2,VWN2,VWT4,VW12,VW22,VX,VXB,VXB2,VXE,VXEB,VXE4,VXE6,VXG,VXQ4,VXTB,VXT1,VXU,VXU1,VX26,WMT8
			-	-	2	1000085	VXP,VXQP
	90047-ZE3-791	BOLT, STUD, 8X40	2	-	-	-----	VMS2,VMX2
	92900-08032-0E	BOLT, STUD, 8X32	2	2	2	-----	ES1/A,ES3/A,HAP,HAP/A,HA2/A,HEA2/A,HEA8/A,HX/A,HXQ4/A,HX26/A,HX8/A,LH/A,LHB5,LHE/A,LJ/A,LJC/A,LJG/A,LT,LT/A,LW/A,LWD1,LWD1/A,LX/A,LXE/A,LXE8/A,LXQ4/A,LXU/A,L1/A,PAE2/A,PA2/A,PA/A,PXE8,PXE8/A,PXU/A,PX26/A,QAB3/A,QAE2/A,QAE6/A,QAG,QAG/A,QAG2,QAG2/A,QAQ4/A,QAR2/A,QAW,QAW/A,QA2/A,QD/A,QE/A,QH/A,QHB5,QHE4/A,QHP1/A,QHQ4/A,QHR,QHR/A,QHR4,QHR4/A,QHZ/A,QH26/A,QKE3/A,QKE4,QL2,QME2/A,QMH/A,QP/A,QSC9/A,QSE/A,QSE2,QSE8/A,QT/A,QWA2,QWA4,QWA4/A,QWH2,QWH2/A,QX/A,QXB/A,QXB6/A,QXB7,QXB7/A,QXC4/A,QXC6/A,QXC9/A,QXE/A,QXE4/A,QXE6/A,QXE8/A,QXQ4/A,QXU/A,QX26/A,Q1/A,RA2/A,RD/A,RHE4/A,RHQ4/A,RH26/A,RSC2/A,RSS,RSS/A,RX/A,RXP,RXP/A,RXQ4/A,RXU/A,R1/A,SD/A,SE/A,SH/A,SHQ4/A,SJ/A,SJG/A,SMC4/A,SME1/A,SME6/A,SMX2,SN/A,SWA4,SWC4/A,SX/A,SXB/A,SXB7,SXB7/A,SXE/A,SXEB/A,SXE4/A,SXE8/A,SXQ4/A,SXU/A,S1/A,VAG2,VAG2/A,VA2/A,VDE2/A,VKB2/A,VKE4,VKX4,VMA4,VME2/A,VME4,VMT,VMT/A,VM2/A,VNG1/A,VNT2/A,VN17,VN17/A,VPE4/A,VPE7,VPE7/A,VPX4/A,VPX7,VPX7/A,VSD/A,VSD3/A,VSD7,VSD7/A,VSH7,VS3,VS37,VS37/A,VWA2/A,VWN2/A,VWT4/A,VW12/A,VX/A,VXB/A,VXB7,VXB7/A,VXEB/A,VXE4/A,VXE6/A,VXE7,VXE7/A,VXP/A,VXQ4/A,VXT1/A,VXU/A,VXU1/A,WMA4,WMT8/A,WXE8,WXE8/A,W1,W1/A
			2	2	-	1457780	ES1,ES3,HA2,HEA2,HEA8,HX,HXQ4,HX26,HX8,LH,LHE,LJ,LJC,LJG,LSS,LTJ,LW,LWD,LX,LXE,LXE8,LXQ4,LXU,LX16,L1,PAE2,PA2,PX,PXU,PX26,QAB3,QAE2,QAE6,QAQ4,QAR2,QA2,QD,QE,QH,QHE4,QHP1,QHQ4,QHZ,QH26,QKE3,QME2,QMH,QP,QSC9,QSE,QSE8,QT,QX,QXB,QXB6,QXC4,QXC6,QXC9,QXE,QXE4,QXE6,QXE8,QXQ4,QXU,QX26,Q1,RA2,RD,RH,RHE4,RHQ4,RH26,RSC2,RX,RXQ4,RXU,R1,SD,SE,SH,SHQ4,SJ,SJG,SKE1,SMC4,SMD,SME1,SME6,SN,SW,SWC4,SX,SXB,SXE,SXEB,SXE4,SXE8,SXQ4,SXU,S1,VA2,VDE,VDE2,VD16,VH,VKB2,VME2,VM2,VNG1,VNT2,VPE4,VPX4,VSD,VSD3,VWA2,VWN2,VWT4,VW12,VW22,VX,VXB,VXB2,VXE,VXEB,VXE4,VXE6,VXG,VXQ4,VXTB,VXT1,VXU,VXU1,VX26,WMT8
			-	-	2	1000086	VXP,VXQP
14	90441-ZE2-010	WASHER COMP., HEAD COVER	1	1	1		
15	94301-12200	DOWEL PIN, 12X20	2	2	2		
16	95725-10080-00	BOLT, FLANGE, 10X80	4	4	4		
17	98079-55841	PLUG, SPARK (BP5ES)(NGK)	(1)	-	-	-----	LJ,LJ/A,LJC,LJC/A,LJG,LJG/A,LSS,LT,LT/A,LTJ,LWD1,LWD1/A,QD,QD/A,RD,RD/A,SD,SD/A,SJ,SJ/A,SJG,SJG/A,SK,SN,SN/A
			-	(1)	-		



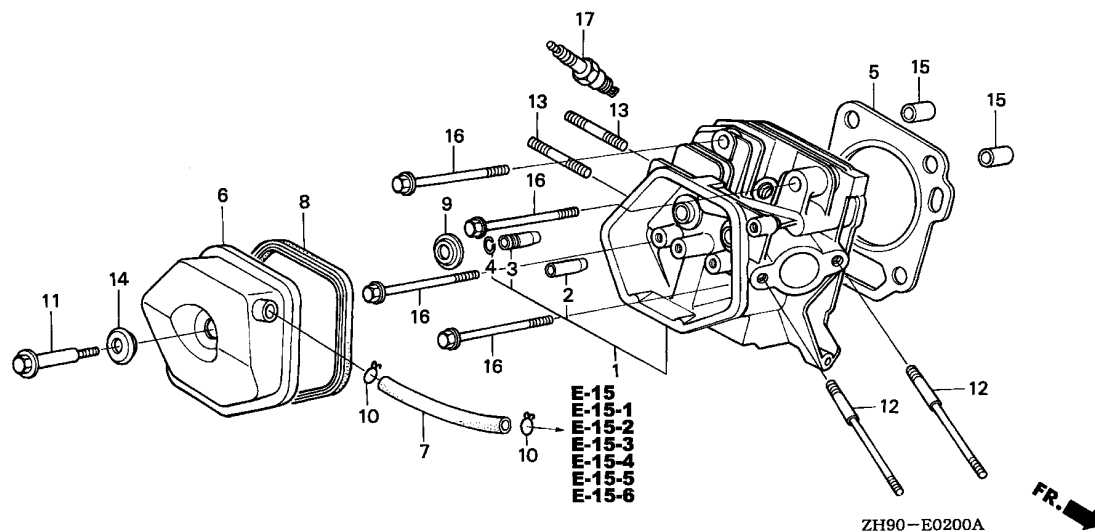

Ref. No.	Part No.	Description	Reqd. QTY			Serial No.	Parts catalogue code
			(1)	(2)	(3)		
17)	98079-55846	PLUG, SPARK (BPR5ES)(NGK) ...	1	-	-	HA2,HA2/A,HX26,HX26/A,PX26,PX26/A,QAE6,QAE6/A,QAQ4,QAQ4/A,QHE4,QHE4/A,QH26,QH26/A,QXC4,QXC4/A,QXC6,QXC6/A,QXE4,QXE4/A,QXE6,QXE6/A,QX26,QX26/A,RHE4,RHE4/A,RH26,RH26/A,SXE4,SXE4/A,VKE4,VKX4,VMT,VMT/A,VPE4,VPE4/A,VPE5,VPX4,VPX4/A,VPX5,VS3,VXE4,VXE4/A,VXE6,VXE6/A,VXQ4,VXQ4/A	
			(1)	-	-	ESS,ESS/A,ES1,ES1/A,ES3,ES3/A,HA,HAQ,HEA,HEA2,HEA2/A,HEA8,HEA8/A,HH,HX,HX/A,HXQ4,HXQ4/A,HX8,HX8/A,LH,LH/A,LHB1,LHB3,LHB5,LHE,LHE/A,LHQ4,LW,LW/A,LWD,LX,LX/A,LXE,LXE/A,LXE8,LXE8/A,LXQ4,LXQ4/A,LXU,LXU/A,LXZ,LX16,PA,PAE2,PAE2/A,PA2,PA2/A,PX,PX/A,PXE8,PXE8/A,PXU,PXU/A,QA,QAB1,QAB3,QAB3/A,QAE,QAE2,QAE2/A,QAG,QAG/A,QAG2,QAG2/A,QAQ,QAR2,QAR2/A,QAW,QAW/A,QA2,QA2/A,QE,QE/A,QH,QH/A,QHB5,QHC,QHE,QHP1,QHP1/A,QHQ4,QHQ4/A,QHR,QHR/A,QHR4,QHR4/A,QHZ,QHZ/A,QL2,QMH,QMH/A,QP,QP/A,QSC,QSC9,QSC9/A,QSE,QSE/A,QSE2,QSE8,QSE8/A,QT,QT/A,QWA2,QWA4,QWA4/A,QWH2,QWH2/A,QX,QX/A,QXB,QXB/A,QXB6,QXB6/A,QXB7,QXB7/A,QXC,QXC9,QXC9/A,QXE,QXE/A,QXEB,QXE8,QXE8/A,QXQ4,QXQ4/A,QXU,QXU/A,RA,RA2,RA2/A,RH,RHE,RHQ4,RHQ4/A,RSC2,RSC2/A,RSS,RSS/A,RX,RX/A,RXQ4,RXQ4/A,RXU,RXU/A,SE,SE/A,SH,SH/A,SHE,SHZ,SHQ4,SHQ4/A,SJP,SKE1,SMD,SMX2,SW,SWA4,SWC4,SWC4/A,SWE,SX,SX/A,SXB,SXB/A,SXB7,SXB7/A,SXE,SXE/A,SXEB,SXEB/A,SXE8,SXE8/A,SXQ4,SXQ4/A,SXU,SXU/A,SX2,VA,VAG2,VAG2/A,VAW,VAW1,VA2,VA2/A,VDE,VDE2,VDE2/A,VD16,VEB6,VH,VKB2,VKB2/A,VMA4,VME2,VME2/A,VME4,VMS2,VMX2,VM2,VM2/A,VNG1,VNG1/A,VNT2,VNT2/A,VN17,VN17/A,VPE7,VPE7/A,VPX7,VPX7/A,VSD,VSD/A,VSD3,VSD3/A,VSD7,VSD7/A,VSH7,VS37,VS37/A,VWA,VWA2,VWA2/A,VWN2,VWN2/A,VWT4,VWT4/A,VW12,VW12/A,VW22,VX,VX/A,VXB,VXB/A,VXB2,VXB6,VXB7,VXB7/A,VXE,VXEB,VXEB/A,VXE7,VXE7/A,VXG,VXTB,VXT1,VXT1/A,VXU,VXU/A,VXU1,VXU1/A,VX26,WMA4,WMT8,WMT8/A,WXE8,WXE8/A	
			-	(1)	(1)		

Ref. No.	Part No.	Description	Reqd. QTY			Serial No.	Parts catalogue code
			(1)	GX270 (2)	(3)		
17)	98079-55854	PLUG, SPARK (W16EP-U) (DENSO)	(1)	-	-	-----	LJ,LJ/A,LJC,LJC/A,LJG,LJG/A,LSS,LT,LT/A,LTJ,LWD1,LWD1/A,QD,QD/A, RD,RD/A,SD,SD/A,SJ,SJ/A,SJG,SJG/A,SK,SN,SN/A
	98079-55855	PLUG, SPARK (W16EPR-U) (DENSO)	-	(1)	-	-----	ESS,ESS/A,VKE4,VKX4,VMT,VMT/A,VPE4,VPE4/A,VPE5,VPE7,VPE7/A,VPX4, VPX4/A,VPX5,VPX7,VPX7/A,VSD3,VSD3/A,VS3,VS37,VS37/A
			(1)	-	-	-----	ES1,ES1/A,ES3,ES3/A,HA,HAQ,HA2,HA2/A,HEA,HEA2,HEA2/A,HEA8,HEA8/A, HH,HX,HX/A,HXQ4,HXQ4/A,HX26,HX26/A,HX8,HX8/A,LH,LH/A,LHB1,LHB3, LHB5,LHE,LHE/A,LHQ4,LW,LW/A,LWD,LX,LX/A,LXE,LXE/A,LXE8,LXE8/A, LXQ4,LXQ4/A,LXU,LXU/A,LXZ,LX16,PA,PAE2,PAE2/A,PA2,PA2/A,PX,PX/A, PXE8,PXE8/A,PXU,PXU/A,PX26,PX26/A,QA,QAB1,QAB3,QAB3/A,QAE,QAE2, QAE2/A,QAE6,QAE6/A,QAG,QAG/A,QAG2,QAG2/A,QAQ,QAQ4,QAQ4/A,QAR2, QAR2/A,QAW,QAW/A,QA2,QA2/A,QE,QE/A,QH,QH/A,QHB5,QHC,QHE,QHE4, QHE4/A,QHP1,QHP1/A,QHQ4,QHQ4/A,QHR,QHR/A,QHR4,QHR4/A,QHZ,QHZ/A, QH26,QH26/A,QL2,QMH,QMH/A,QP,QP/A,QSC,QSC9,QSC9/A,QSE,QSE/A,QSE2, QSE8,QSE8/A,QT,QT/A,QWA2,QWA4,QWA4/A,QWH2,QWH2/A,QX,QX/A,QXB, QXB/A,QXB6,QXB6/A,QXB7,QXB7/A,QXC,QXC4,QXC4/A,QXC6,QXC6/A,QXC9, QXC9/A,QXE,QXE/A,QXEB,QXE4,QXE4/A,QXE6,QXE6/A,QXE8,QXE8/A,QXQ4, QXQ4/A,QXU,QXU/A,QX26,QX26/A,RA,RA2,RA2/A,RH,RHE,RHE4,RHE4/A,RHQ4, RHQ4/A,RH26,RH26/A,RSC2,RSC2/A,RSS,RSS/A,RX,RX/A,RXQ4,RXQ4/A,RXU, RXU/A,SE,SE/A,SH,SH/A,SHE,SHEZ,SHQ4,SHQ4/A,SKE1,SMD,SMX2,SW,SWA4, SWC4,SWC4/A,SWE,SX,SX/A,SXB,SXB/A,SXB7,SXB7/A,SXE,SXE/A,SXEB, SXEB/A,SXE4,SXE4/A,SXE8,SXE8/A,SXQ4,SXQ4/A,SXU,SXU/A,SX2,VA,VAG2, VAG2/A,VAW,VAW1,VA2,VA2/A,VDE,VDE2,VDE2/A,VD16,VEB6,VH,VKB2, VKB2/A,VMA4,VME2,VME2/A,VME4,VMS2,VMX2,VM2,VM2/A,VNG1,VNG1/A,VNT2, VNT2/A,VN17,VN17/A,VSD,VSD/A,VSD7,VSD7/A,VSH7,VWA,VWA2,VWA2/A, VWN2,VWN2/A,VWT4,VWT4/A,VW12,VW12/A,VW22,VX,VX/A,VXB,VXB/A,VXB2, VXB6,VXB7,VXB7/A,VXE,VXEB,VXEB/A,VXE4,VXE4/A,VXE6,VXE6/A,VXE7, VXE7/A,VXG,VXQ4,VXQ4/A,VXTB,VXT1,VXT1/A,VXU,VXU/A,VXU1,VXU1/A, VX26,WMA4,WMT8,WMT8/A,WXE8,WXE8/A
	98079-56841	PLUG, SPARK (BP6ES) (NGK)	-	(1)	(1)	-----	ES1,ES1/A,ES3,ES3/A,LHB3,LJ,LJ/A,LJC,LJC/A,LJG,LJG/A,LSS,LT,LT/A, LTJ,LWD1,LWD1/A,QD,QD/A,QT,QT/A,RD,RD/A,SD,SD/A,SJ,SJ/A,SJG,SJG/A, SJP,SK,SN,SN/A
			1	-	-	-----	1471451 QHZ
			-	(1)	-	-----	



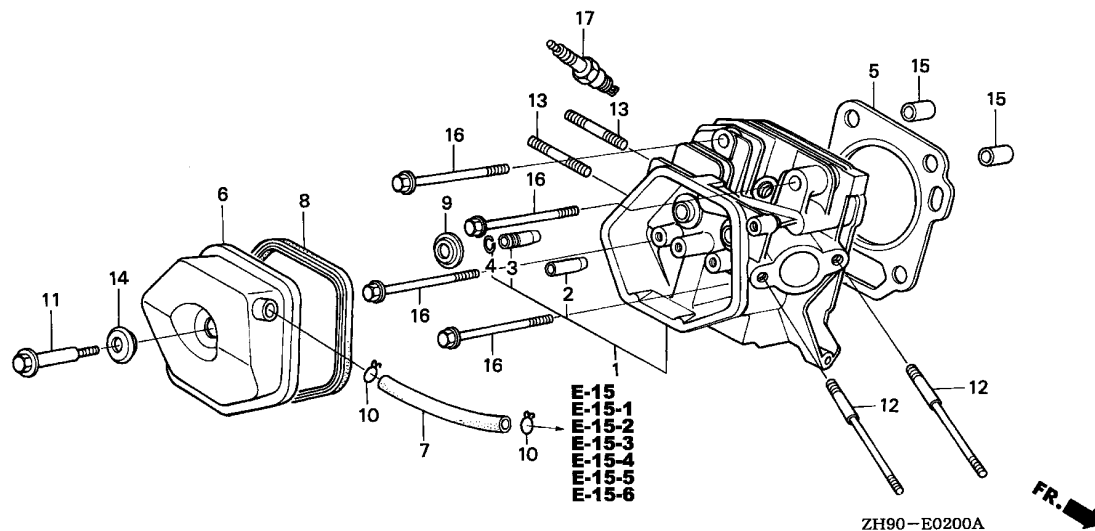

Ref. No.	Part No.	Description	Reqd. QTY			Serial No.	Parts catalogue code
			(1)	(2)	(3)		
17)	98079-56846	PLUG, SPARK (BPR6ES)(NGK) ...	1	-	-	-----	HA,HAQ,HA2,HA2/A,HEA,HEA2,HEA2/A,HEA8,HEA8/A,HH,HX,HX/A,HXQ4 HXQ4/A,HX26,HX26/A,HX8,HX8/A,LH,LH/A,LHB1,LHB3,LHB5,LHE,LHE/A LHQ4,LW,LW/A,LWD,LX,LX/A,LXE,LXE/A,LXE8,LXE8/A,LXQ4,LXQ4/A,LXU LXU/A,LXZ,LX16,PA,PAE2,PAE2/A,PA2,PA2/A,PX,PX/A,PXE8,PXE8/A,PXU PXU/A,PX26,PX26/A,QA,QAB1,QAB3,QAB3/A,QAE,QAE2,QAE2/A,QAE6,QAE6/A QAG,QAG/A,QAG2,QAG2/A,QAQ,QAQ4,QAQ4/A,QAR2,QAR2/A,QAW,QAW/A,QA2 QA2/A,QE,QE/A,QH,QH/A,QHB5,QHC,QHE,QHE4,QHE4/A,QHP1,QHP1/A,QHQ4 QHQ4/A,QHR,QHR/A,QHR4,QHR4/A,QHZ/A,QH26,QH26/A,QKE3,QKE3/A,QKE4 QL2,QME2,QME2/A,QMH,QMH/A,QP,QP/A,QSC,QSC9,QSC9/A,QSE,QSE/A,QSE2 QSE8,QSE8/A,QWA2,QWA4,QWA4/A,QWH2,QWH2/A,QX,QX/A,QXB,QXB/A,QXB6 QXB6/A,QXB7,QXB7/A,QXC,QXC4,QXC4/A,QXC6,QXC6/A,QXC9,QXC9/A,QXE QXE/A,QXEB,QXE4,QXE4/A,QXE6,QXE6/A,QXE8,QXE8/A,QXQ4,QXQ4/A,QXU QXU/A,QX26,QX26/A,RA,RA2,RA2/A,RH,RHE,RHE4,RHE4/A,RHQ4,RHQ4/A RH26,RH26/A,RSC2,RSC2/A,RSS,RSS/A,RX,RX/A,RXQ4,RXQ4/A,RXU,RXU/A SE,SE/A,SH,SH/A,SHE,SHEZ,SHQ4,SHQ4/A,SKE1,SMC4,SMC4/A,SMD,SME1 SME1/A,SME6,SME6/A,SMX2,SW,SWA4,SWC4,SWC4/A,SWE,SX,SX/A,SBX,SBX/A SXB7,SXB7/A,SXE,SXE/A,SXEB,SXEB/A,SXE4,SXE4/A,SXE8,SXE8/A,SXQ4 SXQ4/A,SXU,SXU/A,SX2,VA,VAG2,VAG2/A,VAW,VAW1,VA2,VA2/A,VDE,VDE2 VDE2/A,VD16,VEB6,VH,VKB2,VKB2/A,VMA4,VME2,VME2/A,VME4,VMS2,VMS2 VM2,VM2/A,VNG1,VNG1/A,VNT2,VNT2/A,VN17,VN17/A,VSD,VSD/A,VSD7 VSD7/A,VSH7,VWA,VWA2,VWA2/A,VWN2,VWN2/A,VWT4,VWT4/A,VW12,VW12/A VW22,VX,VX/A,VXB,VXB/A,VXB2,VXB6,VXB7,VXB7/A,VXE,VXEB,VXEB/A,VXE4 VXE4/A,VXE6,VXE6/A,VXE7,VXE7/A,VXG,VXQ4,VXQ4/A,VXTB,VXT1/A VXU,VXU/A,VXU1,VXU1/A,VX26,WMA4,WMT8,WMT8/A,WXE8,WXE8/A QHZ
			1	-	-	1471452 -----	
			-	(1)	1		

Ref. No.	Part No.	Description	Reqd. QTY			Serial No.	Parts catalogue code
			(1)	(2)	(3)		
17)	98079-56854	PLUG, SPARK (W20EP-U) (DENSO)	1	-	-	-----	ES1,ES1/A,ES3,ES3/A,LJ,LJ/A,LJC,LJC/A,LJG,LJG/A,LSS,LT,LT/A,LTJ LWD1,LWD1/A,QD,QD/A,QT,QT/A,RD,RD/A,SD,SD/A,SJ,SJ/A,SJG,SJG/A,SJP SK,SN,SN/A
			1	-	-	-----	1471451 QHZ
	98079-56855	PLUG, SPARK (W20EPR-U) (DENSO)	1	-	-	-----	HA,HAQ,HA2,HA2/A,HEA,HEA2,HEA2/A,HEA8,HEA8/A,HH,HX,HX/A,HXQ4 HXQ4/A,HX26,HX26/A,HX8,HX8/A,LH,LH/A,LHB1,LHB3,LHB5,LHE,LHE/A LHQ4,LW,LW/A,LWD,LX,LX/A,LXE,LXE/A,LXE8,LXE8/A,LXQ4,LXQ4/A,LXU LXU/A,LXZ,LX16,PA,PAE2,PAE2/A,PA2,PA2/A,PX,PX/A,PXE8,PXE8/A,PXU PXU/A,PX26,PX26/A,QA,QAB1,QAB3,QAB3/A,QAE,QAE2,QAE2/A,QAE6,QAE6/A QAG,QAG/A,QAG2,QAG2/A,QAQ,QAQ4,QAQ4/A,QAR2,QAR2/A,QAW,QAW/A,QA2 QA2/A,QE,QE/A,QH,QH/A,QHB5,QHC,QHE,QHE4,QHE4/A,QHP1,QHP1/A,QHQ4 QHQ4/A,QHR,QHR/A,QHR4,QHR4/A,QHZ/A,QH26,QH26/A,QL2,QMH,QMH/A,QP QP/A,QSC,QSC9,QSC9/A,QSE,QSE/A,QSE2,QSE8,QSE8/A,QWA2,QWA4,QWA4/A QWH2,QWH2/A,QX,QX/A,QXB,QXB/A,QXB6,QXB6/A,QXB7,QXB7/A,QXC,QXC4 QXC4/A,QXC6,QXC6/A,QXC9,QXC9/A,QXE,QXE/A,QXEB,QXE4,QXE4/A,QXE6 QXE6/A,QXE8,QXE8/A,QXQ4,QXQ4/A,QXU,QXU/A,QX26,QX26/A,RA,RA2,RA2/A RH,RHE,RHE4,RHE4/A,RHQ4,RHQ4/A,RH26,RH26/A,RSC2,RSC2/A,RSS,RSS/A RX,RX/A,RXQ4,RXQ4/A,RXU,RXU/A,SE,SE/A,SH,SH/A,SHE,SHEZ,SHQ4 SHQ4/A,SKE1,SMD,SMX2,SW,SWA4,SWC4,SWC4/A,SWE,SX,SX/A,SXB,SXB/A SXB7,SXB7/A,SXE,SXE/A,SXEB,SXEB/A,SXE4,SXE4/A,SXE8,SXE8/A,SXQ4 SXQ4/A,SXU,SXU/A,SX2,VA,VAG2,VAG2/A,VAW,VAW1,VA2,VA2/A,VDE,VDE2 VDE2/A,VD16,VEB6,VH,VKB2,VKB2/A,VMA4,VME2,VME2/A,VME4,VMS2,VMX2 VM2,VM2/A,VNG1,VNG1/A,VNT2,VNT2/A,VN17,VN17/A,VSD,VSD/A,VSD7 VSD7/A,VSH7,VWA,VWA2,VWA2/A,VWN2,VWN2/A,VWT4,VWT4/A,VW12,VW12/A VW22,VX,VX/A,VXB,VXB/A,VXB2,VXB6,VXB7,VXB7/A,VXE,VXEB,VXEB/A,VXE4 VXE4/A,VXE6,VXE6/A,VXE7,VXE7/A,VXG,VXQ4,VXQ4/A,VXTB,VXT1,VXT1/A VXU,VXU/A,VXU1,VXU1/A,VX26,WMA4,WMT8,WMT8/A,WXE8,WXE8/A
			1	-	-	-----	1471452 QHZ
			-	(1)	-	-----	

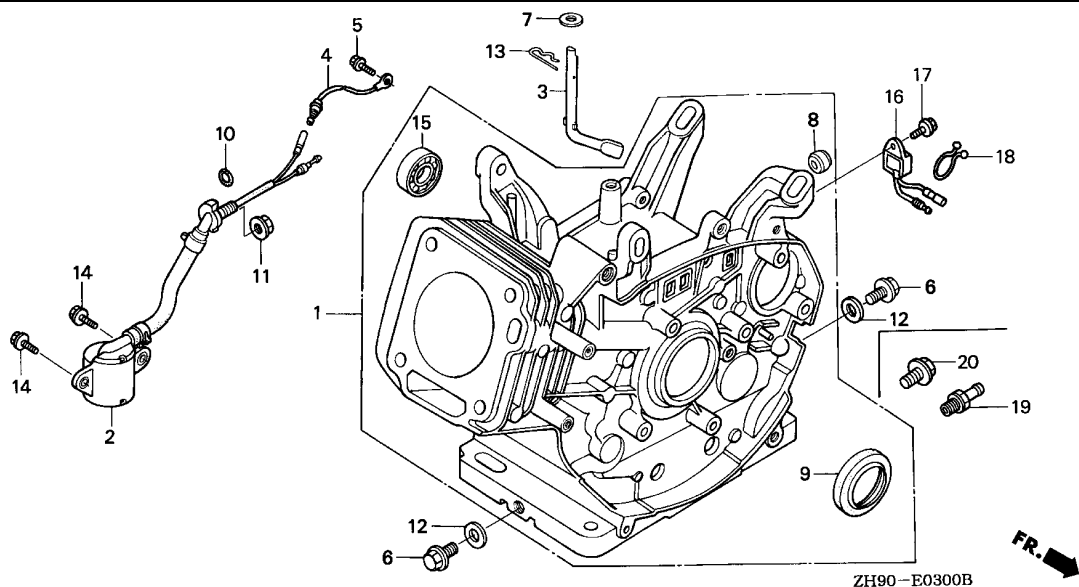

Ref. No.	L.O.N.	(Relative ref. Number) Description	F.R.T.
1	1101A0	BARREL, CYLINDER	1.8
2		(10)	
	6151E8	SWITCH, OIL LEVEL	0.5
	3	1161B4 SHAFT, GOVERNOR ARM	1.1
	4	6111E5 SUB HARNESS, OIL LEVEL SWITCH	0.1
	9	1101E4 OIL SEAL, CRANKSHAFT :FRONT ..	1.1
	15	1101F4 BEARING, BALANCER WEIGHT :FRONT	1.9
	16	6151A0 ALERT UNIT, ENGINE OIL	0.1

Ref. No.	Part No.	Description	Reqd. QTY			Serial No.	Parts catalogue code
			(1)	(2)	(3)		
1	120A0-ZH9-000	BARREL ASSY., CYLINDER (STD.)	1	-	-	1069823 HH,LH,LW,QD,QE,QH,QHC,QP,RD,RH,SD,SE,SH,SW,VH	
			1	-	-	1070054 LJ,SJ	
	120A0-ZH9-800	BARREL ASSY., CYLINDER (ALERT)	1	(1)	-	1069839 L1,Q1,R1,S1,V1,W1	
			1	-	-	1069839 ESS,L1,Q1,R1,SJP,S1,V1,W1	
	120A0-ZH9-810	BARREL ASSY., CYLINDER (SELFSTARTER+ALERT)	1	-	-	1069961 HX,LX,LXZ,PX,QX,QXB,RX,SX,SXB,VNG1,VSD,VSD3,VX,VXB	
			1	-	-	1070139 QXC	
	120A0-ZH9-820	BARREL ASSY., CYLINDER (SELF-STARTER)	1	-	-	1070229 QXE,QXEB,SXE,SXEB,VXE,VXEB	
			1	(1)	-	1069839 L1,Q1,R1,S1,V1,W1	
	120A0-ZH9-850	BARREL ASSY., CYLINDER (BALANCER+ALERT)	1	-	-	1081844 LHE,QHE,RHE,SHE,SHEZ,SWE	
			1	-	-	1097920 LWD	
	120A0-ZH9-860	BARREL ASSY., CYLINDER (BALANCER+SELFSTARTER+ALERT)	1	(1)	-	1069839 L1,Q1,R1,S1,V1,W1	
			1	-	-	1069409 HA,PA,QA,RA,VA,VAW,VWA	
	12000-ZH9-010	BARREL ASSY., CYLINDER (STD.)	1	-	-	1093310 HAQ,HA2,PA2,QAQ,QA2,RA2,VA2	
			1	(1)	-	1069783 HEA,QAE,Q2	
			1	-	-	1121540 QAE2	
			1	-	-	LHB1,LHB3,LHQ4,L1/A,R1/A,S1/A	
			1	-	-	1069824 HH,QHC,RH,SW,VH	
			1	-	-	1070055 SJ	
			1	-	-	1680278 L,JG,LT,QHP1,QHQ4,QHZ,QH26,QMH,QT,RHQ4,RH26,SHQ4,SJG,SN	
			1	-	-	1069824 1680278 LH,LW,QD,QE,QH,QP,RD,SD,SE,SH	
			1	-	-	1680278 LJ	
			1	(1)	-	1069840 L1,R1,S1,V1	
			1	(1)	-	1069840 1680278 Q1,W1	

Ref. No.	Part No.	Description	Reqd. QTY			Serial No.	Parts catalogue code	
			(1)	(2)	(3)			
(1)	12000-ZH9-020	BARREL ASSY., CYLINDER (STD.)	1	(1)	-	-----	QHR,Q1/A,W1/A	
			1	(1)	-	1680279	-----	LH,LJ,LJG,LT,LW,QD,QE,QH,QHP1,QHQ4,QHZ,QH26,QMH,QP,QT,Q1,RD,RHQ4
	12000-ZH9-801	BARREL ASSY., CYLINDER (ALERT)	1	(1)	-	-----	-----	RH26,SD,SE,SH,SHQ4,SJG,SN,W1
			1	(1)	-	1069840	-----	LX16,L1/A,R1/A,SMD,SX2,VD16,VXB2,VXB6,VXG,VX26,W1/A
			1	(1)	-	1069840	1680278	L1,R1,SJP,V1,W1
			1	-	-	1069962	-----	ESS,Q1,S1
			1	-	-	1070140	-----	LXZ
			1	-	-	-----	-----	QXC
			1	-	-	1680278	-----	ES1,ES3,HXQ4,HX26,HX8,LJC,LXQ4,LXU,PXU,PX26,QWA2,QWA4,QXC4,QXC6
								QXC9,QXQ4,QXU,RXQ4,RXU,SMC4,SME6,SWC4,SXQ4,SXU,VMT,VPX4,VXQ4,VXTB
								VXT1,VXU,VXU1,WMT8
			1	-	-	1069962	1680278	HX,LX,PX,QX,QXB,RX,SX,SXB,VNG1,VSD,VSD3,VX,VXB
			-	-	1	-----	-----	VXP,VXQP
	12000-ZH9-802	1	(1)	1	-----	-----	QAG2,QWH2,QXB7,Q1/A,RXP,SXB7,S1/A,VAG2,VN17,VPX7,VSD7,VS37,VXB7
			1	(1)	-	1680279	-----	ESS,ES1,ES3,HX,HXQ4,HX26,HX8,LJC,LX,LXQ4,LXU,PX,PXU,PX26,QWA2
								QWA4,QX,QXB,QXC4,QXC6,QXC9,QXQ4,QXU,Q1,RX,RXQ4,RXU,SMC4,SME6,SWC4
								SX,SXB,SXQ4,SXU,S1,VMT,VNG1,VPX4,VSD,VSD3,VX,VXB,VXQ4,VXTB,VXT1
								VXU,VXU1,WMT8
			-	-	1	1000320	-----	VXP,VXQP
	12000-ZH9-811	BARREL ASSY., CYLINDER (SELFSTARTER+ALERT)	1	(1)	-	-----	-----	L1/A,R1/A,VEB6,W1/A
			1	-	-	1070230	-----	QXEB,VXE
			1	-	-	1680278	-----	LXE,LXE8,QKE3,QME2,QSE,QSE8,QXE4,QXE6,QXE8,SME1,SXE4,SXE8,VPE4
								VWT4,VXE4,VXE6
			1	-	-	1070230	1680278	QXE,SXE,SXEB,VXEB
			-	(1)	-	1069840	-----	L1,R1,V1,W1
			-	(1)	-	1069840	1680278	Q1,S1
	12000-ZH9-812	1	(1)	-	-----	-----	PXE8,Q1/A,S1/A,VKE4,VPE7,VXE7,WXE8
			1	(1)	-	1680279	-----	LXE,LXE8,QKE3,QME2,QSE,QSE8,QXE,QXE4,QXE6,QXE8,Q1,SME1,SXE,SXEB
								SXE4,SXE8,S1,VPE4,VWT4,VXEB,VXE4,VXE6
	12000-ZH9-821	BARREL ASSY., CYLINDER (SELF-STARTER)	1	-	-	1081845	-----	QHE,RHE,SHE,SHEZ,SWE
			1	-	-	1680278	-----	QHE4,QHR4,RHE4,SKE1
			1	-	-	1081845	1680278	LHE
			1	-	-	1097921	1680278	LWD
			-	(1)	-	-----	-----	Q1/A,W1/A
			-	(1)	-	1069840	-----	Q1,V1,W1
			-	(1)	-	1069840	1680278	L1,R1,S1
	12000-ZH9-822	1	(1)	-	1680279	-----	LHE,LWD,L1,QHE4,QHR4,RHE4,R1,SKE1,S1
	12000-ZH9-841	BARREL ASSY., CYLINDER (BALANCER)	1	-	-	-----	-----	LSS,SK
			1	-	-	1680278	-----	RSS
	12000-ZH9-842	1	-	-	1680279	-----	RSS
	12000-ZH9-851	BARREL ASSY., CYLINDER (BALANCER+ALERT)	1	-	-	-----	-----	QAB1,VAW1,VW22
			1	-	-	1069410	-----	HA,PA,QA,RA,VA,VAW,VWA
			1	-	-	1093311	-----	HAQ,QAQ
			1	-	-	1680278	-----	QAB3,QAQ4,QAR2,QAW,QL2,QX26,RSC2,VM2,VNT2,VWA2,VWN2,VW12
			1	-	-	1093311	1680278	HA2,PA2,QA2,RA2,VA2
			-	-	1	-----	-----	HAP
	12000-ZH9-852	1	-	-	-----	-----	QAG
			1	-	-	1680279	-----	HA2,PA2,QAB3,QAQ4,QAR2,QAW,QA2,QL2,QX26,RA2,RSC2,VA2,VM2,VNT2
								VWA2,VWN2,VW12
			-	-	1	1000319	-----	HAP
	12000-ZH9-860	BARREL ASSY., CYLINDER (BALANCER+SELFSTARTER+ALERT)	1	-	-	-----	-----	QSC

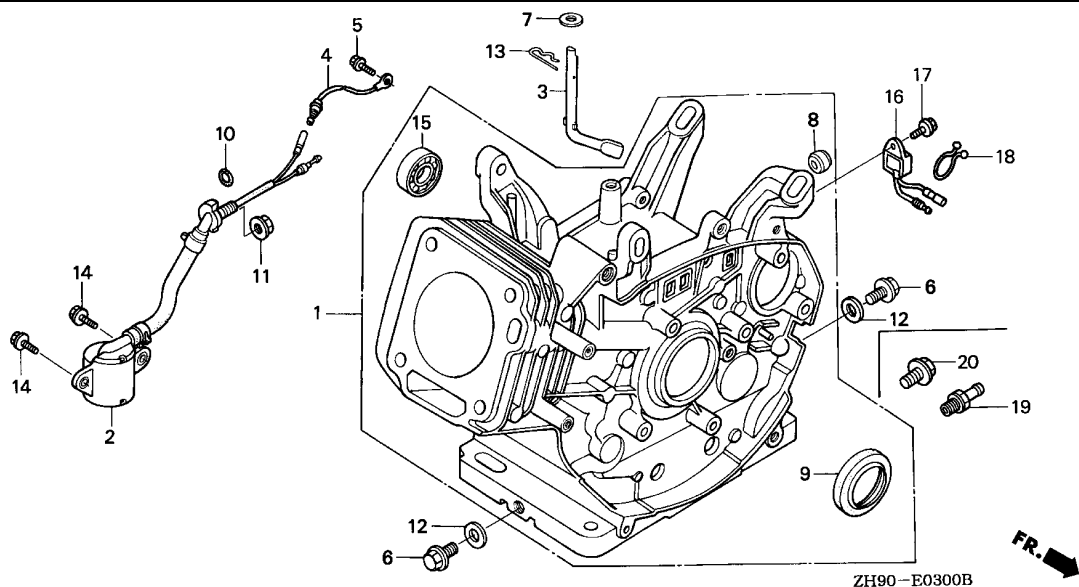

Ref. No.	Part No.	Description	Reqd. QTY			Serial No.	Parts catalogue code
			(1)	(2)	(3)		
(1)	12000-ZH9-861	BARREL ASSY., CYLINDER (BALANCER+SELFSTARTER+ALERT)	1	(1)	-	1069784 -----	HEA,QAE,QSC,Q2 VDE 1680278 HEA2,HEA8,PAE2,QAE6,QSC9,QXB6,VDE2,VKB2,VME2 1121541 1680278 QAE2
	12000-ZH9-862	1	-	-	1680279 -----	HEA2,HEA8,PAE2,QAE2,QAE6,QSC9,QXB6,VDE2,VKB2,VME2
	12000-ZH9-870	BARREL ASSY., CYLINDER (BALANCER+SELFSTARTER)	1	-	-	-----	LTJ 1680278 LWD1
	12000-ZH9-871	1	-	-	1680279 -----	LWD1
	12000-ZH9-Q20	1	-	-	-----	LWD1/A
	12000-ZH9-405	BARREL ASSY., CYLINDER (STD.)	1	-	-	-----	LH/A,LHB5,LJ/A,LJG/A,LT/A,LW/A,QD/A,QE/A,QH/A,QHB5,QHP1/A,QHQ4/A QHR/A,QHZ/A,QH26/A,QMH/A,QP/A,QT/A,RD/A,RHQ4/A,RH26/A,SD/A,SE/A SH/A,SHQ4/A,SJ/A,SJG/A,SN/A
	12000-ZH9-823	BARREL ASSY., CYLINDER (SELF-STARTER)	-	(1)	-	-----	L1/A,R1/A,S1/A
	12000-ZH9-406	BARREL ASSY., CYLINDER (ALERT)	1	-	1	-----	ESS/A,ES1/A,ES3/A,HX/A,HXQ4/A,HX26/A,HX8/A,LJC/A,LX/A,LXQ4/A LXU/A,PX/A,PXU/A,PX26/A,QAG2/A,QWA4/A,QWH2/A,QX/A,QXB/A,QXB7/A QXC4/A,QXC6/A,QXC9/A,QXQ4/A,QXU/A,RX/A,RXP/A,RXQ4/A,RXU/A,SMC4/A SME6/A,SMX2,SWA4,SWC4/A,SX/A,SXB/A,SXB7/A,SXQ4/A,SXU/A,VAG2/A VKX4,VMA4,VMT/A,VNG1/A,VN17/A,VPX4/A,VPX5,VPX7/A,VSD/A,VSD3/A VSD7/A,VSH7,VS3,VS37/A,VX/A,VXB/A,VXB7/A,VXP/A,VXQ4/A,VXT1/A VXU/A,VXU1/A,WMT8/A
	12000-ZH9-408	BARREL ASSY., CYLINDER (SELF-STARTER)	1	-	-	-----	LHE/A,QHE4/A,QHR4/A,RHE4/A
	12000-ZH9-409	BARREL ASSY., CYLINDER (BALANCER)	1	-	-	-----	RSS/A

Ref. No.	Part No.	Description	Reqd. QTY			Serial No.	Parts catalogue code
			(1)	(2)	(3)		
(1)	12000-ZH9-407	BARREL ASSY., CYLINDER (SELFSTARTER+ALERT)	1	-	-		LXE/A, LXE8/A, PXE8/A, QKE3/A, QKE4, QME2/A, QSE/A, QSE2, QSE8/A, QXE/A, QXE4/A, QXE6/A, QXE8/A, SME1/A, SXE/A, SXEB/A, SXE4/A, SXE8/A, VME4, VPE4/A, VPE5, VPE7/A, VWT4/A, VXEB/A, VXE4/A, VXE6/A, VXE7/A, WMA4, WXE8/A
	12000-ZH9-Q00	BARREL ASSY., CYLINDER (BALANCER+ALERT)	1	-	1		HAP/A, HA2/A, PA2/A, QAB3/A, QAG/A, QAQ4/A, QAR2/A, QAW/A, QA2/A, QX26/A, RA2/A, RSC2/A, VA2/A, VMX2, VM2/A, VNT2/A, VWA2/A, VWN2/A, VW12/A
	12000-ZH9-Q10	BARREL ASSY., CYLINDER (BALANCER+SELFSTARTER+ALERT)	1	-	-		HEA2/A, HEA8/A, PAE2/A, QAE2/A, QAE6/A, QSC9/A, QXB6/A, VDE2/A, VKB2/A, VME2/A, VMS2
2	15510-ZE2-043	SWITCH ASSY., OIL LEVEL	1	-	-		ESS, ESS/A, ES1, ES1/A, ES3, ES3/A, HA, HAQ, HA2, HA2/A, HEA, HEA2, HEA2/A, HEA8, HEA8/A, HX, HX/A, HXQ4, HXQ4/A, HX26, HX26/A, HX8, HX8/A, LJC, LJC/A, LX, LX/A, LXE, LXE/A, LXE8, LXE8/A, LXQ4, LXQ4/A, LXU, LXU/A, LXZ, LX16, PA, PAE2, PAE2/A, PA2, PA2/A, PX, PX/A, PXE8, PXE8/A, PXU, PXU/A, PX26, PX26/A, QA, QAB1, QAB3, QAB3/A, QAE, QAE2, QAE2/A, QAE6, QAE6/A, QAG, QAG/A, QAG2, QAG2/A, QAQ, QAQ4, QAQ4/A, QAR2, QAR2/A, QAW, QAW/A, QA2, QA2/A, QKE3, QKE3/A, QKE4, QL2, QME2, QME2/A, QSC, QSC9, QSC9/A, QSE, QSE/A, QSE2, QSE8, QSE8/A, QWA2, QWA4, QWA4/A, QWH2, QWH2/A, QX, QX/A, QXB, QXB/A, QXB6, QXB6/A, QXB7, QXB7/A, QXC, QXC4, QXC4/A, QXC6, QXC6/A, QXC9, QXC9/A, QXE, QXE/A, QXEB, QXE4, QXE4/A, QXE6, QXE6/A, QXE8, QXE8/A, QXQ4, QXQ4/A, QXU, QXU/A, QX26, QX26/A, RA, RA2, RA2/A, RSC2, RSC2/A, RX, RX/A, RXQ4, RXQ4/A, RXU, RXU/A, SJP, SMC4, SMC4/A, SMD, SME1, SME1/A, SME6, SME6/A, SMX2, SWA4, SWC4, SWC4/A, SX, SX/A, SXB, SXB/A, SXB7, SXB7/A, SXE, SXE/A, SXEB, SXEB/A, SXE4, SXE4/A, SXE8, SXE8/A, SXQ4, SXQ4/A, SXU, SXU/A, SX2, VA, VAG2, VAG2/A, VAW, VAW1, VA2, VA2/A, VDE, VDE2, VDE2/A, VD16, VEB6, VKB2, VKB2/A, VKE4, VKX4, VMA4, VME2, VME2/A, VME4, VMS2, VMT, VMT/A, VMX2, VM2, VM2/A, VNG1, VNG1/A, VNT2, VNT2/A, VN17, VN17/A, VPE4, VPE4/A, VPE5, VPE7, VPE7/A, VPX4, VPX4/A, VPX5, VPX7, VPX7/A, VSD, VSD/A, VSD3, VSD3/A, VSD7, VSD7/A, VSH7, VS3, VS37, VS37/A, VWA, VWA2, VWA2/A, VWN2, VWN2/A, VWT4, VWT4/A, VW12, VW12/A, VW22, VX, VX/A, VXB, VXB/A, VXB2, VXB6, VXB7, VXB7/A, VXE, VXEB, VXEB/A, VXE4, VXE4/A, VXE6, VXE6/A, VXE7, VXE7/A, VXG, VXQ4, VXQ4/A, VXT1, VXT1/A, VXU, VXU/A, VXU1, VXU1/A, VX26, WMA4, WMT8, WMT8/A, WXE8, WXE8/A
	3 16541-ZE2-010	SHAFT, GOVERNOR ARM	-	(1)	1		
	4 32197-ZE2-003	SUB HARNESS	1	1	1		
			1	(1)	1	1225386	HAQ, HA2, HEA, HEA2, HXQ4, HX26, LXE, LXQ4, LX16, PA2, PX26, QAB1, QAB3, QAE2, QAE6, QAQ, QAQ4, QAR2, QA2, QME2, QSC, QSC9, QSE, QXC4, QXC6, QXC9, QXE4, QXE6, QXQ4, QX26, Q2, RA2, RSC2, RXQ4, SMC4, SMD, SME1, SME6, SWC4, SXE4, SXQ4, SX2, VAW1, VA2, VDE, VDE2, VD16, VEB6, VSD3, VWA, VWA2, VWN2, VW12, VW22, VXB2, VXB6, VXE4, VXG, VXP, VXQP, VXQ4, VXU, VX26
			1	(1)	-	1033680	1225386 HA, HX, LX, LXZ, L1, PA, PX, QA, QAE, QX, QXB, QXC, QXE, QXEB, Q1, RA, RX, R1, SX, SXB, SXE, SXEB, S1, VA, VAW, VNG1, VSD, VX, VXB, VXE, VXEB, V1, W1
			1	-	-	1033680	SJP
	31161-ZE2-000	CORD, EARTH	1	-	-		ESS/A, ES3, ES3/A, VMT, VMT/A, VS3
			1	-	-	1225387	ESS
5	90013-883-000	BOLT, FLANGE, 6X12(CT200) ...	1	-	-		ESS/A, ES3, ES3/A, VMT, VMT/A, VS3
			1	-	-	1225387	ESS
6	90131-883-000	BOLT, DRAIN PLUG, 12X15	2	2	2		
7	90446-KE1-000	WASHER, 8.2X17X0.8	1	1	1		
8	90801-ZE2-003	PLUG, SEALING (RUBBER 10MM) -	1	(1)	-		HH, LH, LH/A, LHB1, LHB3, LHB5, LHE, LHE/A, LHQ4, LJ, LJ/A, LJG, LJG/A, LSS, LT, LT/A, LTJ, LW, LW/A, LWD, LWD1, LWD1/A, L1, L1/A, QD, QD/A, QE, QE/A, QH, QH/A, QHB5, QHC, QHE, QHE4, QHE4/A, QHP1, QHP1/A, QHQ4, QHQ4/A, QHR, QHR/A, QHR4, QHR4/A, QHZ, QHZ/A, QH26, QH26/A, QMH, QMH/A, QP, QP/A, QT, QT/A, Q1, Q1/A, RD, RD/A, RH, RHE, RHE4, RHE4/A, RHQ4, RHQ4/A, RH26, RH26/A, RSS, RSS/A, R1, R1/A, SD, SD/A, SE, SE/A, SH, SH/A, SHE, SHEZ, SHQ4, SHQ4/A, SJ, SJ/A, SJG, SJG/A, SKE1, SN, SN/A, SW, SWE, S1, S1/A, VH, V1, W1, W1/A
9	91201-890-003	OIL SEAL, 30X46X8	1	1	1		



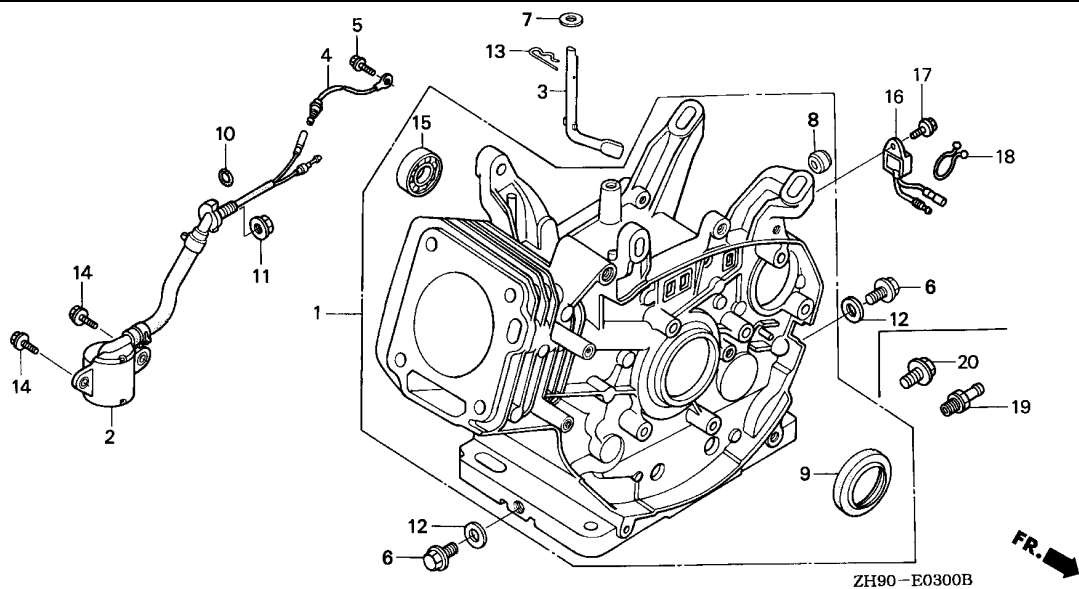

Ref. No.	Part No.	Description	Reqd. QTY			Serial No.	Parts catalogue code
			(1)	(2)	(3)		
10	91353-671-004	O-RING, 14MM(NOK)	1	-	-		ESS,ESS/A,ES1,ES1/A,ES3,ES3/A,HA,HAQ,HA2,HA2/A,HEA,HEA2,HEA2/A,HEA8,HEA8/A,HX,HX/A,HXQ4,HXQ4/A,HX26,HX26/A,HX8,HX8/A,LJC,LJC/A,LX,LX/A,LXE,LXE/A,LXE8,LXE8/A,LXQ4,LXQ4/A,LXU,LXU/A,LXZ,LX16,PA,PAE2,PAE2/A,PA2,PA2/A,PX,PX/A,PXE8,PXE8/A,PXU,PXU/A,PX26,PX26/A,QA,QAB1,QAB3,QAB3/A,QAE,QAE2,QAE2/A,QAE6,QAE6/A,QAG,QAG/A,QAG2,QAG2/A,QAQ,QAQ4,QAQ4/A,QAR2,QAR2/A,QAW,QAW/A,QA2,QA2/A,QKE3,QKE3/A,QKE4,QL2,QME2,QME2/A,QSC,QSC9,QSC9/A,QSE,QSE/A,QSE2,QSE8,QSE8/A,QWA2,QWA4,QWA4/A,QWH2,QWH2/A,QX,QX/A,QXB,QXB/A,QXB6,QXB6/A,QXB7,QXB7/A,QXC,QXC4,QXC4/A,QXC6,QXC6/A,QXC9,QXC9/A,QXE,QXE/A,QXEB,QXE4,QXE4/A,QXE6,QXE6/A,QXE8,QXE8/A,QXQ4,QXQ4/A,QXU,QXU/A,QX26,QX26/A,RA,RA2,RA2/A,RSC2,RSC2/A,RX,RX/A,RXQ4,RXQ4/A,RXU,RXU/A,SJP,SMC4,SMC4/A,SMD,SME1,SME1/A,SME6,SME6/A,SMX2,SWA4,SWC4,SWC4/A,SX,SX/A,SXB,SXB/A,SXB7,SXB7/A,SXE,SXE/A,SXEB,SXEB/A,SXE4,SXE4/A,SXE8,SXE8/A,SXQ4,SXQ4/A,SXU,SXU/A,SX2,VA,VAG2,VAG2/A,VAW,VAW1,VA2,VA2/A,VDE,VDE2,VDE2/A,VD16,VEB6,VKB2,VKB2/A,VKE4,VKX4,VMA4,VME2,VME2/A,VME4,VMS2,VMT,VMT/A,VMX2,VM2,VM2/A,VNG1,VNG1/A,VNT2,VNT2/A,VN17,VN17/A,VPE4,VPE4/A,VPE5,VPE7,VPE7/A,VPX4,VPX4/A,VPX5,VPX7,VPX7/A,VSD,VSD/A,VSD3,VSD3/A,VSD7,VSD7/A,VSH7,VS3,VS37,VS37/A,VWA,VWA2,VWA2/A,VWN2,VWN2/A,VWT4,VWT4/A,VW12,VW12/A,VW22,VX,VX/A,VXB,VXB/A,VXB2,VXB6,VXB7,VXB7/A,VXE,VXE8,VXE8/A,VXE4,VXE4/A,VXE6,VXE6/A,VXE7,VXE7/A,VXG,VXQ4,VXQ4/A,VXTB,VXT1,VXT1/A,VXU,VXU/A,VXU1,VXU1/A,VX26,WMA4,WMT8,WMT8/A,WXE8,WXE8/A

- (1) 1

Ref. No.	Part No.	Description	Reqd. QTY			Serial No.	Parts catalogue code
			(1)	(2)	(3)		
11	94050-10000	NUT, FLANGE, 10MM	1	-	-	-----	ESS,ESS/A,ES1,ES1/A,ES3,ES3/A,HA,HAQ,HA2,HA2/A,HEA,HEA2,HEA2/A,HEA8,HEA8/A,HX,HX/A,HXQ4,HXQ4/A,HX26,HX26/A,HX8,HX8/A,LJC,LJC/A,LX,LX/A,LXE,LXE/A,LXE8,LXE8/A,LXQ4,LXQ4/A,LXU,LXU/A,LXZ,LX16,PA,PAE2,PAE2/A,PA2,PA2/A,PX,PX/A,PXE8,PXE8/A,PXU,PXU/A,PX26,PX26/A,QA,QAB1,QAB3,QAB3/A,QAE,QAE2,QAE2/A,QAE6,QAE6/A,QAG,QAG/A,QAG2,QAG2/A,QAQ,QAQ4,QAQ4/A,QAR2,QAR2/A,QAW,QAW/A,QA2,QA2/A,QKE3,QKE3/A,QKE4,QKE4/A,QME2,QME2/A,QSC,QSC9,QSC9/A,QSE,QSE/A,QSE2,QSE8,QSE8/A,QWA2,QWA4,QWA4/A,QWH2,QWH2/A,QX,QX/A,QXB,QXB/A,QXB6,QXB6/A,QXB7,QXB7/A,QXC,QXC4,QXC4/A,QXC6,QXC6/A,QXC9,QXC9/A,QXE,QXE/A,QXEB,QXE4,QXE4/A,QXE6,QXE6/A,QXE8,QXE8/A,QXQ4,QXQ4/A,QXU,QXU/A,QX26,QX26/A,RA,RA2,RA2/A,RSC2,RSC2/A,RX,RX/A,RXQ4,RXQ4/A,RXU,RXU/A,SJP,SMC4,SMC4/A,SMD,SME1,SME1/A,SME6,SME6/A,SMX2,SWA4,SWC4,SWC4/A,SX,SX/A,SXB,SXB/A,SXB7,SXB7/A,SXE,SXE/A,SXEB,SXEB/A,SXE4,SXE4/A,SXE8,SXE8/A,SXQ4,SXQ4/A,SXU,SXU/A,SX2,VA,VAG2,VAG2/A,VAW,VAW1,VA2,VA2/A,VDE,VDE2,VDE2/A,VD16,VEB6,VKB2,VKB2/A,VKE4,VKX4,VMA4,VME2,VME2/A,VME4,VMS2,VMT,VMT/A,VMX2,VM2,VM2/A,VNG1,VNG1/A,VNT2,VNT2/A,VN17,VN17/A,VPE4,VPE4/A,VPE5,VPE7,VPE7/A,VPX4,VPX4/A,VPX5,VPX7,VPX7/A,VSD,VSD/A,VSD3,VSD3/A,VSD7,VSD7/A,VSH7,VS3,VS37,VS37/A,VWA,VWA2,VWA2/A,VWN2,VWN2/A,VWT4,VWT4/A,VW12,VW12/A,VW22,VX,VX/A,VXB,VXB/A,VXB2,VXB6,VXB7,VXB7/A,VXE,VXEB,VXEB/A,VXE4,VXE4/A,VXE6,VXE6/A,VXE7,VXE7/A,VXG,VXQ4,VXQ4/A,VXTB,VXT1,VXT1/A,VXU,VXU/A,VXU1,VXU1/A,VX26,WMA4,WMT8,WMT8/A,WXE8,WXE8/A
			-	(1)	1		
12	94109-12000	WASHER, DRAIN PLUG, 12MM	2	2	2		
13	94251-08000	PIN, LOCK, 8MM	1	1	-	-----	1116513 HA,HAQ,HA2,HEA,HH,HX,LH,LHE,LW,LX,LXZ,PA,PA2,PX,QA,QAE,QAE2,QAQ,QA2,QD,QE,QH,QHC,QHE,QP,QSC,QX,QXB,QXC,QXE,QXEB,Q2,RA,RA2,RD,RH,RHE,RX,SD,SE,SH,SHE,SHEZ,SN,SW,SWE,SX,SXB,SXE,SXEB,VA,VAW,VAW1,VA2,VDE,VH,VNG1,VSD,VSD3,VWA,VX,VXB,VXE,VXEB,VXG,VXU
			1	1	-	-----	1116745 ESS,LJ,LJG,LSS,LTJ,LWD,L1,Q1,R1,SJ,SJG,SJP,SK,S1,V1,W1



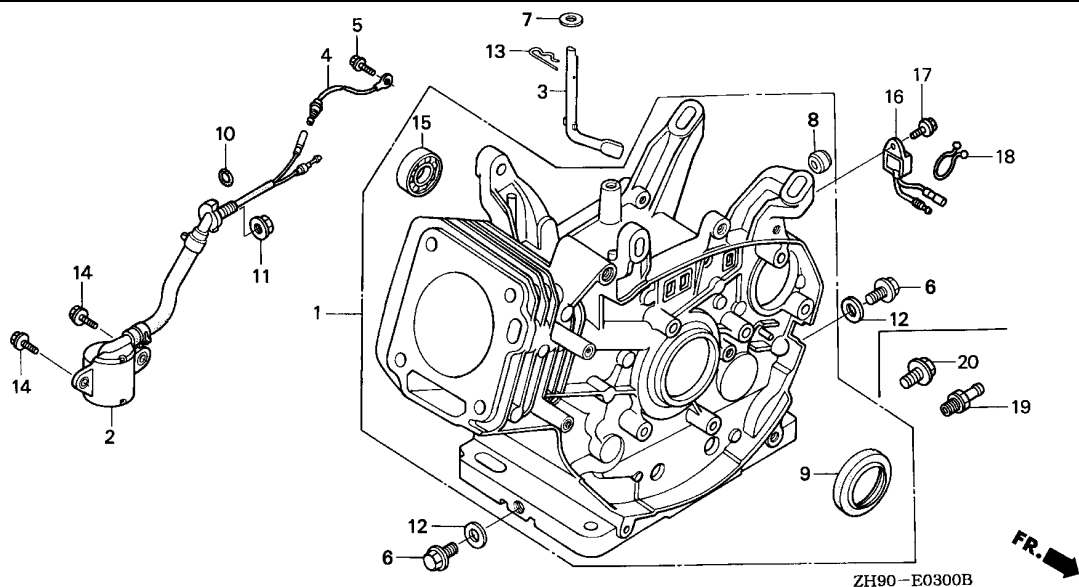

Ref. No.	Part No.	Description	Reqd. QTY			Serial No.	Parts catalogue code
			(1)	(2)	(3)		
13)	94251-10000	PIN, LOCK, 10MM	1	1	-	-----	ESS/A, ES1, ES1/A, ES3, ES3/A, HA2/A, HEA2, HEA2/A, HEA8, HEA8/A, HX/A, HXQ4, HXQ4/A, HX26, HX26/A, HX8, HX8/A, LH/A, LHB1, LHB3, LHB5, LHE/A, LHQ4, LJ/A, LJC, LJC/A, LJG/A, LT, LT/A, LW/A, LWD1, LWD1/A, LX/A, LXE, LXE/A, LXE8, LXE8/A, LXQ4, LXQ4/A, LXU, LXU/A, LX16, L1/A, PAE2, PAE2/A, PA2/A, PX/A, PXE8, PXE8/A, PXU, PXU/A, PX26, PX26/A, QAB1, QAB3, QAB3/A, QAE2/A, QAE6, QAE6/A, QAG, QAG/A, QAG2, QAG2/A, QAQ4, QAQ4/A, QAR2, QAR2/A, QAW, QAW/A, QA2/A, QD/A, QE/A, QH/A, QHB5, QHE4, QHE4/A, QHP1, QHP1/A, QHQ4, QHQ4/A, QHR, QHR/A, QHR4, QHR4/A, QHZ, QHZ/A, QH26, QH26/A, QKE3, QKE3/A, QKE4, QL2, QME2, QME2/A, QMH, QMH/A, QP/A, QSC9, QSC9/A, QSE, QSE/A, QSE2, QSE8, QSE8/A, QT, QT/A, QWA2, QWA4, QWA4/A, QWH2, QWH2/A, QX/A, QXB/A, QXB6, QXB6/A, QXB7, QXB7/A, QXC4, QXC4/A, QXC6, QXC6/A, QXC9, QXC9/A, QXE/A, QXE4, QXE4/A, QXE6, QXE6/A, QXE8, QXE8/A, QXQ4, QXQ4/A, QXU, QXU/A, QX26, QX26/A, Q1/A, RA2/A, RD/A, RHE4, RHE4/A, RHQ4, RHQ4/A, RH26, RH26/A, RSC2, RSC2/A, RSS, RSS/A, RX/A, RXQ4, RXQ4/A, RXU, RXU/A, R1/A, SD/A, SE/A, SH/A, SHQ4, SHQ4/A, SJ/A, SJG/A, SKE1, SMC4, SMC4/A, SMD, SME1, SME1/A, SME6, SME6/A, SMX2, SN/A, SWA4, SWC4, SWC4/A, SX/A, SXB/A, SXB7, SXB7/A, SXE/A, SXEB/A, SXE4, SXE4/A, SXE8, SXE8/A, SXQ4, SXQ4/A, SXU, SXU/A, SX2, S1/A, VAG2, VAG2/A, VA2/A, VDE2, VDE2/A, VD16, VEB6, VKB2, VKB2/A, VKE4, VKX4, VMA4, VME2, VME2/A, VME4, VMS2, VMT, VMT/A, VMX2, VM2, VM2/A, VNG1/A, VNT2, VNT2/A, VN17, VN17/A, VPE4, VPE4/A, VPE5, VPE7, VPE7/A, VPX4, VPX4/A, VPX5, VPX7, VPX7/A, VSD/A, VSD3/A, VSD7, VSD7/A, VSH7, VS3, VS37, VS37/A, VWA2, VWA2/A, VWN2, VWN2/A, VWT4, VWT4/A, VW12, VW12/A, VW22, VX/A, VXB/A, VXB2, VXB6, VXB7, VXB7/A, VXEB/A, VXE4, VXE4/A, VXE6, VXE6/A, VXE7, VXE7/A, VXQ4, VXQ4/A, VXTB, VXT1, VXT1/A, VXU/A, VXU1, VXU1/A, VX26, WMA4, WMT8, WMT8/A, WXE8, WXE8/A, W1/A

Ref. No.	Part No.	Description	Reqd. QTY			Serial No.	Parts catalogue code
			(1)	GX270 (2)	(3)		
13)	94251-10000	PIN, LOCK, 10MM	1	1	-	1116514 -----	HA,HAQ,HA2,HEA,HH,HX,LH,LHE,LW,LX,LXZ,PA,PA2,PX,QA,QAE,QAE2,QAQ QA2,QD,QE,QH,QHC,QHE,QP,QSC,QX,QXB,QXC,QXE,QXEB,Q2,RA,RA2,RD,RH RHE,RX,SD,SE,SH,SHE,SHEZ,SN,SW,SWE,SX,SBX,SXE,SXEB,VA,VAW,VAW1 VA2,VDE,VH,VNG1,VSD,VSD3,VWA,VX,VXB,VXE,VXEB,VXG,VXU
			1	1	-	1116746 -----	ESS,LJ,LJG,LSS,LTJ,LWD,L1,Q1,R1,SJ,SJG,SJP,SK,S1,V1,W1
14	95701-06012-00	BOLT, FLANGE, 6X12	2	-	-	-----	ESS,ESS/A,ES1,ES1/A,ES3,ES3/A,HA,HAQ,HA2,HA2/A,HEA,HEA2,HEA2/A HEA8,HEA8/A,HX,HX/A,HXQ4,HXQ4/A,HX26,HX26/A,HX8,HX8/A,LJC,LJC/A LX,LX/A,LXE,LXE/A,LXE8,LXE8/A,LXQ4,LXQ4/A,LXU,LXU/A,LXZ,LX16,PA PAE2,PAE2/A,PA2,PA2/A,PX,PX/A,PXE8,PXE8/A,PXU,PXU/A,PX26,PX26/A QA,QAB1,QAB3,QAB3/A,QAE,QAE2,QAE2/A,QAE6,QAE6/A,QAG,QAG/A,QAG2 QAG2/A,QAQ,QAQ4,QAQ4/A,QAR2,QAR2/A,QAW,QAW/A,QA2,QA2/A,QKE3 QKE3/A,QKE4,QL2,QME2,QME2/A,QSC,QSC9,QSC9/A,QSE,QSE/A,QSE2,QSE8 QSE8/A,QWA2,QWA4,QWA4/A,QWH2,QWH2/A,QX,QX/A,QXB,QXB/A,QXB6,QXB6/A QXB7,QXB7/A,QXC,QXC4,QXC4/A,QXC6,QXC6/A,QXC9,QXC9/A,QXE,QXE/A QXEB,QXE4,QXE4/A,QXE6,QXE6/A,QXE8,QXE8/A,QXQ4,QXQ4/A,QXU,QXU/A QX26,QX26/A,RA,RA2,RA2/A,RSC2,RSC2/A,RX,RX/A,RXQ4,RXQ4/A,RXU RXU/A,SJP,SMC4,SMC4/A,SMD,SME1,SME1/A,SME6,SME6/A,SMX2,SWA4,SWC4 SWC4/A,SX,SX/A,SBX,SBX/A,SBX7,SBX7/A,SXE,SXE/A,SXE8,SXE8/A,SXE4 SXE4/A,SXE8,SXE8/A,SXQ4,SXQ4/A,SXU,SXU/A,SX2,VA,VAG2,VAG2/A,VAW VAW1,VA2,VA2/A,VDE,VDE2,VDE2/A,VD16,VEB6,VKB2,VKB2/A,VKE4,VKX4 VMA4,VME2,VME2/A,VME4,VMS2,VMT,VMT/A,VMX2,VM2,VM2/A,VNG1,VNG1/A VNT2,VNT2/A,VN17,VN17/A,VPE4,VPE4/A,VPE5,VPE7,VPE7/A,VPX4,VPX4/A VPX5,VPX7,VPX7/A,VSD,VSD/A,VSD3,VSD3/A,VSD7,VSD7/A,VSH7,VS3,VS37 VS37/A,VWA,VWA2,VWA2/A,VWN2,VWN2/A,VWT4,VWT4/A,VW12,VW12/A,VW22 VX,VX/A,VXB,VXB/A,VXB2,VXB6,VXB7,VXB7/A,VXE,VXEB,VXEB/A,VXE4 VXE4/A,VXE6,VXE6/A,VXE7,VXE7/A,VXG,VXG4,VXQ4/A,VXTB,VXT1/VXT1/A VXU,VXU/A,VXU1,VXU1/A,VX26,WMA4,WMT8,WMT8/A,WXE8,WXE8/A
15	96100-62020-00	BEARING, RADIAL BALL, 6202 ..	1	(2)	2	-----	HA,HAP,HAP/A,HAQ,HA2,HA2/A,HEA,HEA2,HEA2/A,HEA8,HEA8/A,LSS,LTJ LWD1,LWD1/A,PA,PAE2,PAE2/A,PA2,PA2/A,QA,QAB1,QAB3,QAB3/A,QAE,QAE2 QAE2/A,QAE6,QAE6/A,QAG,QAG/A,QAQ,QAQ4,QAQ4/A,QAR2,QAR2/A,QAW QAW/A,QA2,QA2/A,QL2,QSC,QSC9,QSC9/A,QXB6,QXB6/A,QX26,QX26/A,Q2,RA RA2,RA2/A,RSC2,RSC2/A,RSS,RSS/A,SK,VA,VAW,VAW1,VA2,VA2/A,VDE,VDE2 VDE2/A,VKB2,VKB2/A,VME2,VME2/A,VMS2,VMX2,VM2,VM2/A,VNT2,VNT2/A VWA,VWA2,VWA2/A,VWN2,VWN2/A,VW12,VW12/A,VW22
16	34150-ZH7-003	ALERT UNIT, OIL	1	(1)	1	-----	ESS/A,ES1/A,ES3/A,HAP,HAP/A,HA2/A,HX/A,HXQ4/A,HX26/A,HX8,HX8/A LJC,LJC/A,LX/A,LXQ4/A,LXU,LXU/A,PA2/A,PX/A,PXU,PXU/A,PX26/A QAB3/A,QAG,QAG/A,QAG2,QAG2/A,QAQ4/A,QAR2/A,QAW,QAW/A,QKE3/A QL2,QME2/A,QWA2,QWA4,QWA4/A,QWH2,QWH2/A,QX/A,QXB/A,QXB7,QXB7/A QXC4/A,QXC6/A,QXC9/A,QXQ4/A,QXU,QXU/A,QX26/A,Q1/A,RA2/A,RSC2/A RX/A,RXP,RXP/A,RXQ4/A,RXU,RXU/A,SMC4/A,SME1/A,SME6/A,SMX2,SWA4 SWC4/A,SX/A,SBX/A,SBX7,SBX7/A,SXQ4/A,SXU,SXU/A,S1/A,VAG2,VAG2/A VA2/A,VKE4,VKX4,VMA4,VME4,VMT,VMT/A,VMX2,VM2/A,VNG1/A,VNT2/A,VN17 VN17/A,VPE4/A,VPE5,VPE7,VPE7/A,VPX4/A,VPX5,VPX7,VPX7/A,VSD/A VSD3/A,VSD7,VSD7/A,VSH7,VS3,VS37,VS37/A,VWA2/A,VWN2/A,VWT4/A VW12/A,VX/A,VXB/A,VXB7,VXB7/A,VXP/A,VXQ4/A,VXT1,VXT1/A,VXU/A,VXU1 VXU1/A,WMT8,WMT8/A
			1	(1)	-	1321603 -----	ESS,ES1,ES3,HA2,HX,HXQ4,HX26,LX,LXQ4,LX16,PA2,PX,PX26,QAB3,QAQ4 QAR2,QA2,QKE3,QME2,QX,QXB,QXC4,QXC6,QXC9,QXQ4,QX26,Q1,RA2,RSC2,RX RXQ4,SMC4,SMD,SME1,SME6,SWC4,SX,SBX,SXQ4,S1,VA2,VD16,VM2,VNG1 VNT2,VPE4,VPX4,VSD,VSD3,VWA2,VWN2,VWT4,VW12,VW22,VX,VXB,VXB2,VXG VXQ4,VXTB,VXU,VX26
			-	-	1	1000070 -----	VXP,VXQP



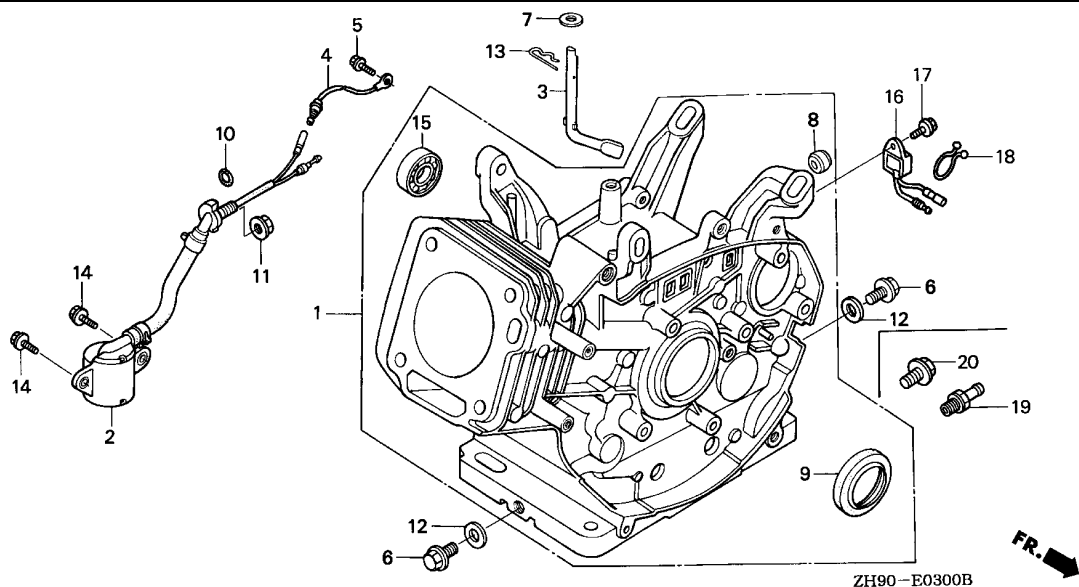

Ref. No.	Part No.	Description	Reqd. QTY			Serial No.	Parts catalogue code	
			(1)	(2)	(3)			
17	90013-883-000	BOLT, FLANGE, 6X12(CT200) ...	1	(1)	1	-----	ESS/A,ES1/A,ES3/A,HAP,HAP/A,HA2/A,HX/A,HXQ4/A,HX26/A,HX8,HX8/A,LJC,LJC/A,LX/A,LXQ4/A,LXU,LXU/A,PA2/A,PX/A,PXU,PXU/A,PX26/A,QAB3/A,QAG,QAG/A,QAG2,QAG2/A,QAQ4/A,QAR2/A,QAW,QAW/A,QA2/A,QKE3/A,QL2,QME2/A,QWA2,QWA4,QWA4/A,QWH2,QWH2/A,QX/A,QXB/A,QXB7,QXB7/A,QXC4/A,QXC6/A,QXC9/A,QXQ4/A,QXU,QXU/A,QX26/A,Q1/A,RA2/A,RSC2/A,RX/A,RXP,RXP/A,RXQ4/A,RXU,RXU/A,SMC4/A,SME1/A,SME6/A,SMX2,SWA4,SWC4/A,SX/A,SXB/A,SXB7/A,SXB7/A,SXQ4/A,SXU,SXU/A,S1/A,VAG2,VAG2/A,VA2/A,VKE4,VKX4,VMA4,VME4,VMT,VMT/A,VMX2,VM2/A,VNG1/A,VNT2/A,VN17,VN17/A,VPE4/A,VPE5,VPE7,VPE7/A,VPX4/A,VPX5,VPX7,VPX7/A,VSD/A,VSD3/A,VSD7,VSD7/A,VSH7,VS3,VS37,VS37/A,VWA2/A,VWN2/A,VWT4/A,VW12/A,VX/A,VXB/A,VXB7/A,VXP/A,VXQ4/A,VXT1,VXT1/A,VXU/A,VXU1,VXU1/A,WMT8,WMT8/A	
			1	(1)	-	1321603	-----	ESS,ES1,ES3,HA2,HX,HXQ4,HX26,LX,LXQ4,LX16,PA2,PX,PX26,QAB3,QAQ4,QAR2,QA2,QKE3,QME2,QX,QXB,QXC4,QXC6,QXC9,QXQ4,QX26,Q1,RA2,RSC2,RX,RXQ4,SMC4,SMD,SME1,SME6,SWC4,SX,SXB,SXQ4,S1,VA2,VD16,VM2,VNG1,VNT2,VPE4,VPX4,VSD,VSD3,VWA2,VWN2,VWT4,VW12,VW22,VX,VXB,VXB2,VXG,VXQ4,VXTB,VXU,VX26
18	90630-751-000	CLIP, PURSE LOCK	1	-	-	1000070	-----	VXP,VXQP
			1	-	-	1350461	-----	VSD3/A,VS37,VS37/A
19	90131-ZE3-790	PLUG, OIL DRAIN	1	-	-	-----	-----	VSD3
20	92800-12000	BOLT, DRAIN PLUG, 12MM	1	-	-	-----	-----	SMX2

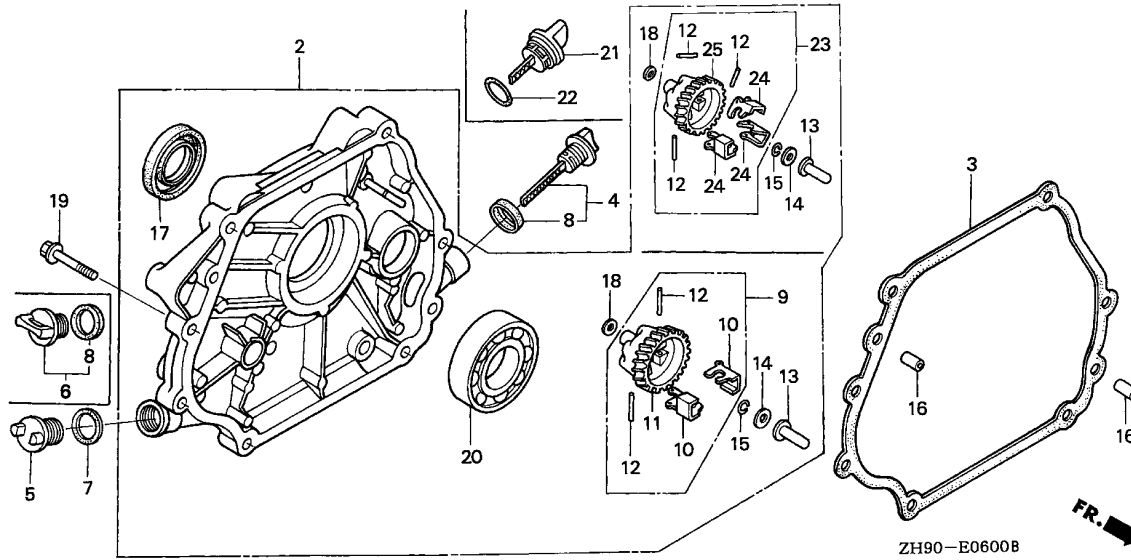

Ref. No.	L.O.N.	(Relative ref. Number) Description	F.R.T.
2	1101F1	COVER, CRANKCASE	0.2
3	1101E9	PACKING, CRANKCASE COVER (10,24,25)	0.2
11	1161A7	HOLDER, GOVERNOR WEIGHT	0.3
13	1161B6	SLIDER, GOVERNOR	0.3
17	1101E5	OIL SEAL, CRANKSHAFT :REAR ...	0.3
20	1101A6	BEARING, CRANKSHAFT :REAR	0.4

Ref. No.	Part No.	Description	Reqd. QTY			Serial No.	Parts catalogue code
			(1)	(2)	(3)		
2	11300-ZE2-000	COVER ASSY., CRANKCASE	1	1	-	1832354	RD, RHE4, RHQ4, RH26, RX, RXQ4, RXU, R1, SD, SE, SH, SHQ4, SJG, SMC4, SME1, SME6, SN, SWC4, SX, SXB, SXE, SXEB, SXE4, SXE8, SXQ4, SXU, S1
	11300-ZE2-600	1	1	1	-----	RH, RHE, SHE, SHEZ, SJ, SJP, SKE1, SMD, SW, SWE, SX2, QHC, QHE, QWA2, QXC, QXEB, VD16, VEB6, VH, VXB2, VXB6, VXE, VXG, VXQP, VXTB, VX26, V1
		1	1	-	1832354	PX, PXE8, PXU, PX26, QAG2, QD, QE, QH, QHE4, QHP1, QHQ4, QHR, QHR4, QHZ, QH26, QKE3, QME2, QMH, QP, QSE, QSE8, QT, QWA4, QWH2, QX, QXB, QXC4, QXC6, QXC9, QXE, QXE4, QXE6, QXE8, QXQ4, QXU, Q1, VNG1, VN17, VPE4, VPE7, VPX4, VSD, VSD3, VMT4, VX, VXB, VXE8, VXE4, VXE6, VXQ4, VXT1, VXU, VXU1
	11300-ZE2-630	1	1	-	1832354	WMT8, WXE8, W1
	11300-ZE2-E70	1	-	-	1832354	ES1
	11300-ZE2-010	1	1	-	1832355	RD, RHE4, RHQ4, RH26, RX, RXQ4, RXU, R1, SD, SE, SH, SHQ4, SJG, SMC4, SME1, SME6, SN, SWC4, SX, SXB, SXE, SXEB, SXE4, SXE8, SXQ4, SXU, S1
	11300-ZE2-601	1	-	1	-----	RXP, SXB7
		1	1	-	1832355	PX, PXE8, PXU, PX26, QAG2, QD, QE, QH, QHE4, QHP1, QHQ4, QHR, QHR4, QHZ, QH26, QKE3, QME2, QMH, QP, QSE, QSE8, QT, QWA4, QWH2, QX, QXB, QXC4, QXC6, QXC9, QXE, QXE4, QXE6, QXE8, QXQ4, QXU, Q1, VNG1, VN17, VPE4, VPE7, VPX4, VSD, VSD3, VMT4, VX, VXB, VXE8, VXE4, VXE6, VXQ4, VXT1, VXU, VXU1
	11300-ZE2-631	1	-	1	-----	QXB7, VAG2, VPX7, VSD7, VS37, VXB7, VXE7, VXP
	11300-ZE2-E71	1	-	-	1832355	WMT8, WXE8, W1
	11300-ZE2-020	1	1	1	-----	ES1
		1	1	1	-----	RD/A, RHE4/A, RHQ4/A, RH26/A, RX/A, RXP/A, RXQ4/A, RXU/A, R1/A, SD/A, SE/A, SH/A, SHQ4/A, SJ/A, SJG/A, SMC4/A, SME1/A, SME6/A, SN/A, SWA4, SWC4/A, SX/A, SXB/A, SXB7/A, SXE/A, SXEB/A, SXE4/A, SXE8/A, SXQ4/A, SXU/A, S1/A, VMA4, VME4

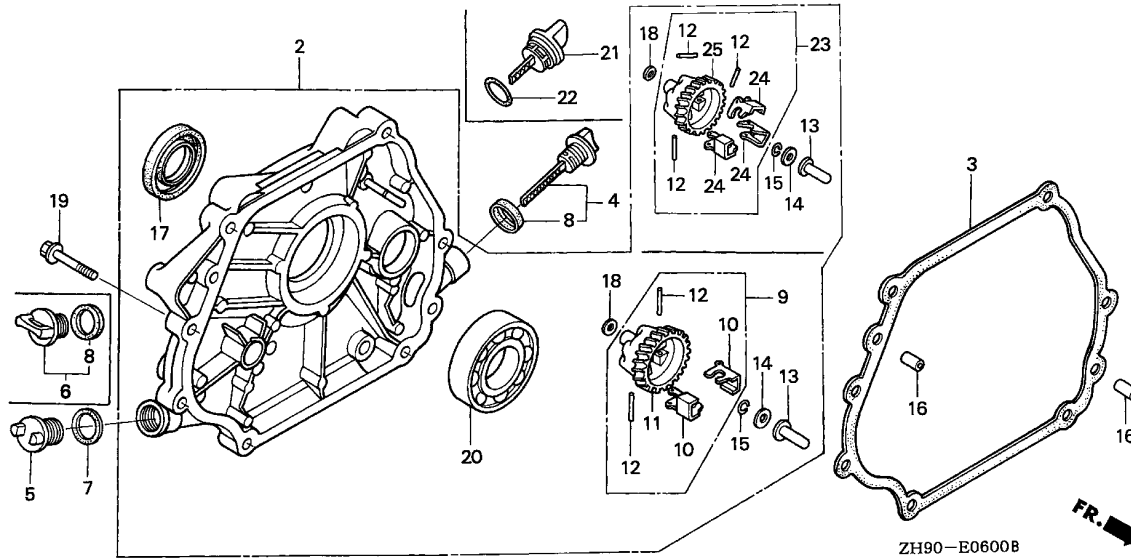

Ref. No.	Part No.	Description	Reqd. QTY			Serial No.	Parts catalogue code
			(1)	(2)	(3)		
(2)	11300-ZE2-602	COVER ASSY., CRANKCASE	1	1	1		PX/A,PXE8/A,PXU/A,PX26/A,QAG2/A,QD/A,QE/A,QH/A,QHB5,QHE4/A,QHP1/A,QHQ4/A,QHR/A,QHR4/A,QHZ/A,QH26/A,QKE3/A,QKE4,QME2/A,QMH/A,QP/A,QSE/A,QSE2,QSE8/A,QT/A,QWA4/A,QWH2/A,QX/A,QXB/A,QXB7/A,QXC4/A,QXC6/A,QXC9/A,QXE/A,QXE4/A,QXE6/A,QXE8/A,QXQ4/A,QXU/A,Q1/A,VAG2/A,VKE4,VKX4,VNG1/A,VN17/A,VPE7/A,VPX7/A,VSD/A,VSD3/A,VSD7/A,VSH7,VS37/A,VWT4/A,VX/A,VXB/A,VXEB/A,VXE4/A,VXE6/A,VXP/A,VXQ4/A,VXT1/A,VXU/A,VXU1/A
			1	-	-	2134945	VPE4/A,VPX4/A,VXB7/A,VXE7/A
	11300-ZE2-405	1	-	-		ES1/A
	11300-ZE2-632	1	1	-		WMA4,WMT8/A,WXE8/A,W1/A
	11300-ZH9-S50	1	-	-		SMX2,VS3
	11300-ZK9-U60	1	-	-		VPE5,VPX5
			1	-	-	2134946	VPE4/A,VPX4/A,VXB7/A,VXE7/A

Ref. No.	Part No.	Description	Reqd. QTY			Serial No.	Parts catalogue code
			(1)	(2)	(3)		
3	11381-ZE2-801	PACKING, CASE COVER	1	(1)	1	-----	ES1,ES1/A,PX,PX/A,PXE8,PXE8/A,PXU,PXU/A,PX26,PX26/A,QAG2,QAG2/A,QD,QD/A,QE,QE/A,QH,QH/A,QHB5,QHC,QHE,QHE4,QHE4/A,QHP1,QHP1/A,QHQ4,QHQ4/A,QHR,QHR/A,QHR4,QHR4/A,QHZ,QHZ/A,QH26,QH26/A,QKE3,QKE3/A,QKE4,QME2,QME2/A,QMH,QMH/A,QP,QP/A,QSE,QSE/A,QSE2,QSE8/A,QT,QT/A,QWA2,QWA4,QWA4/A,QWH2,QWH2/A,QX,QX/A,QXB,QXB/A,QXB7,QXB7/A,QXC,QXC4,QXC4/A,QXC6,QXC6/A,QXC9,QXC9/A,QXE,QXE/A,QXEB,QXE4,QXE4/A,QXE6,QXE6/A,QXE8,QXE8/A,QXQ4,QXQ4/A,QXU,QXU/A,Q1,Q1/A,RD,RD/A,RH,RHE,RHE4,RHE4/A,RHQ4,RHQ4/A,RH26,RH26/A,RX,RX/A,RXP,RXP/A,RXQ4,RXQ4/A,RXU,RXU/A,R1,R1/A,SD,SD/A,SE,SE/A,SH,SH/A,SHE,SHEZ,SHQ4,SHQ4/A,SJ,SJ/A,SJG,SJG/A,SJP,SKE1,SMC4,SMC4/A,SMD,SME1,SME1/A,SME6,SME6/A,SMX2,SN,SN/A,SW,SWA4,SWC4,SWC4/A,SWE,SX,SX/A,SXB,SXB/A,SXB7,SXB7/A,SXE,SXE/A,SXEB,SXEB/A,SXE4,SXE4/A,SXE8,SXE8/A,SXQ4,SXQ4/A,SXU,SXU/A,SX2,S1,S1/A,VAG2,VAG2/A,VD16,VEB6,VH,VKE4,VKX4,VMA4,VME4,VNG1,VNG1/A,VN17,VN17/A,VPE4,VPE4/A,VPE5,VPE7,VPE7/A,VPX4,VPX4/A,VPX5,VPX7,VPX7/A,VSD,VSD/A,VSD3,VSD3/A,VSD7,VSD7/A,VSH7,VS3,VS37,VS37/A,VWT4,VWT4/A,VX,VX/A,VXB,VXB/A,VXB2,VXB6,VXB7,VXB7/A,VXE,VXEB,VXEB/A,VXE4,VXE4/A,VXE6,VXE6/A,VXE7,VXE7/A,VXG,VXP,VXP/A,VXQP,VXQ4,VXQ4/A,VXTB,VXT1,VXT1/A,VXU,VXU/A,VXU1,VXU1/A,VX26,V1,WMA4,WMT8,WMT8/A,WXE8,WXE8/A,W1,W1/A
4	15600-735-700	CAP ASSY., OIL FILLER	1	(1)	-	1071798	PX,QD,QE,QH,QHC,QHE,QP,QX,QXB,QXC,QXE,QXEB,Q1,RD,RH,RHE,RX,R1,SD,SE,SH,SHE,SHEZ,SJ,SJP,SW,SWE,SX,SXB,SXE,SXEB,S1,VH,VNG1,VSD,VSD3,VX,VXB,VXE,VXEB,V1,W1
	15600-735-003	1	(1)	1	-----	PX/A,PXE8,PXE8/A,PXU,PXU/A,PX26,PX26/A,QAG2,QAG2/A,QD/A,QE/A,QH/A,QHB5,QHE4,QHE4/A,QHP1,QHP1/A,QHQ4,QHQ4/A,QHR,QHR/A,QHR4,QHR4/A,QHZ,QHZ/A,QH26,QH26/A,QKE3,QKE3/A,QKE4,QME2,QME2/A,QMH,QMH/A,QP/A,QSE,QSE/A,QSE2,QSE8,QSE8/A,QT,QT/A,QWA2,QWA4,QWA4/A,QWH2,QWH2/A,QX/A,QXB/A,QXB7,QXB7/A,QXC4,QXC4/A,QXC6,QXC6/A,QXC9,QXC9/A,QXE/A,QXE4,QXE4/A,QXE6,QXE6/A,QXE8,QXE8/A,QXQ4,QXQ4/A,QXU,QXU/A,Q1/A,RD/A,RHE4,RHE4/A,RHQ4,RHQ4/A,RH26,RH26/A,RX/A,RXP,RXP/A,RXQ4,RXQ4/A,RXU,RXU/A,R1/A,SD/A,SE/A,SH/A,SHQ4,SHQ4/A,SJ/A,SJG,SJG/A,SKE1,SMC4,SMC4/A,SMD,SME1,SME1/A,SME6,SME6/A,SMX2,SN,SN/A,SWA4,SWC4,SWC4/A,SX/A,SXB/A,SXB7,SXB7/A,SXE/A,SXEB/A,SXE4,SXE4/A,SXE8,SXE8/A,SXQ4,SXQ4/A,SXU,SXU/A,SX2,S1/A,VAG2,VAG2/A,VD16,VEB6,VKE4,VKX4,VMA4,VME4,VNG1/A,VN17,VN17/A,VPE4,VPE4/A,VPE5,VPE7/VPE7/A,VPX4,VPX4/A,VPX5,VPX7,VPX7/A,VSD/A,VSD3/A,VSD7,VSD7/A,VSH7,VS3,VS37,VS37/A,VWT4,VWT4/A,VX/A,VXB/A,VXB2,VXB6,VXB7/VXB7/A,VXEB/A,VXE4,VXE4/A,VXE6,VXE6/A,VXE7,VXE7/A,VXG,VXP,VXP/A,VXQP,VXQ4,VXQ4/A,VXTB,VXT1,VXT1/A,VXU,VXU/A,VXU1,VXU1/A,VX26,WMA4,WMT8,WMT8/A,WXE8,WXE8/A,W1/A
			1	(1)	-	1071799	PX,QD,QE,QH,QHC,QHE,QP,QX,QXB,QXC,QXE,QXEB,Q1,RD,RH,RHE,RX,R1,SD,SE,SH,SHE,SHEZ,SJ,SJP,SW,SWE,SX,SXB,SXE,SXEB,S1,VH,VNG1,VSD,VSD3,VX,VXB,VXE,VXEB,V1,W1
5	15620-ZG4-910	CAP, OIL FILLER	1	1	-	1071798	PX,QD,QE,QH,QHC,QHE,QP,QX,QXB,QXE,QXEB,Q1,RD,RH,RHE,RX,R1,SD,SE,SH,SHE,SHEZ,SJ,SJP,SW,SWE,SX,SXB,SXE,SXEB,S1,VH,VNG1,VSD,VSD3,VX,VXB,VXE,VXEB,V1,W1
			1	-	-	-----	QXC



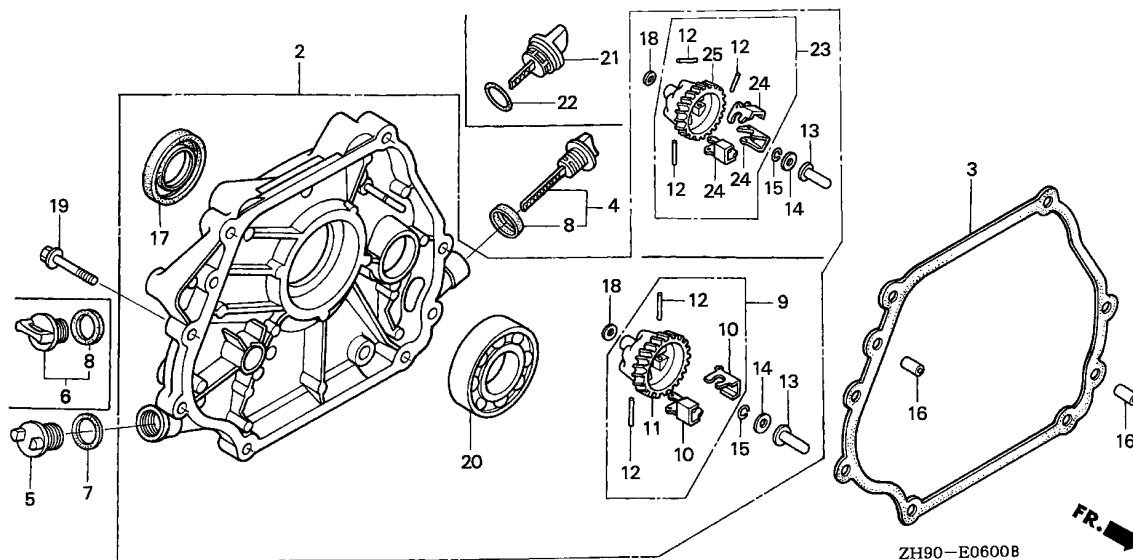

Ref. No.	Part No.	Description	Reqd. QTY			Serial No.	Parts catalogue code
			(1)	(2)	(3)		
6	15600-ZG4-003	CAP ASSY., OIL FILLER	1	1	1	-----	PX/A,PXE8,PXE8/A,PXU,PXU/A,PX26,PX26/A,QAG2,QAG2/A,QD/A,QE/A,QH/A,QHB5,QHE4,QHE4/A,QHP1,QHP1/A,QHQ4,QHQ4/A,QHR,QHR/A,QHR4/A,QHZ,QHZ/A,QH26,QH26/A,QKE3,QKE3/A,QKE4,QME2,QME2/A,QMH,QMH/A,QP/A,QSE,QSE/A,QSE2,QSE8,QSE8/A,QT,QT/A,QWA2,QWA4,QWA4/A,QWH2,QWH2/A,QX/A,QXB/A,QXB7,QXB7/A,QXC4,QXC4/A,QXC6,QXC6/A,QXC9,QXC9/A,QXE/A,QXE4,QXE4/A,QXE6,QXE6/A,QXE8,QXE8/A,QXQ4,QXQ4/A,QXU,QXU/A,Q1/A,RD/A,RHE4,RHE4/A,RHQ4,RHQ4/A,RH26,RH26/A,RX/A,RXP,RXP/A,RXQ4,RXQ4/A,RXU,RXU/A,R1/A,SD/A,SE/A,SH/A,SHQ4,SHQ4/A,SJ/A,SJG,SJG/A,SKE1,SMC4,SMC4/A,SMD,SME1,SME1/A,SME6,SME6/A,SMX2,SN,SN/A,SWA4,SWC4,SWC4/A,SX/A,SXB/A,SXB7,SXB7/A,SXE/A,SXEB/A,SXE4,SXE4/A,SXE8,SXE8/A,SXQ4,SXQ4/A,SXU,SXU/A,SX2,S1/A,VAG2,VAG2/A,VD16,VEB6,VKE4,VKX4,VMA4,VME4,VNG1/A,VN17,VN17/A,VPE4,VPE4/A,VPE5,VPE7,VPE7/A,VPX4,VPX4/A,VPX5,VPX7,VPX7/A,VSD/A,VSD3/A,VSD7,VSD7/A,VSH7,VSD3,VS37,VS37/A,VWT4,VWT4/A,VX/A,VXB/A,VXB2,VXB6,VXB7,VXB7/A,VXEB/A,VXE4,VXE4/A,VXE6,VXE6/A,VXE7,VXE7/A,VXG,VXP,VXP/A,VXQP,VXQ4,VXQ4/A,VXTB,VXT1,VXT1/A,VXU,VXU/A,VXU1,VXU1/A,VX26,WMA4,WMT8,WMT8/A,WXE8,WXE8/A,W1/A
			1	1	-	1071799	-----PX,QD,QE,QH,QHC,QHE,QP,QX,QXB,QXC,QXE,QXEB,Q1,RD,RH,RHE,RX,R1,SD,SE,SH,SHE,SHEZ,SJ,SJP,SW,SWE,SX,SXB,SXE,SXEB,S1,VH,VNG1,VSD,VSD3,VX,VXB,VXE,VXEB,V1,W1
7	15621-896-010	PACKING, OIL FILLER CAP	1	1	-	1071798	-----PX,QD,QE,QH,QHC,QHE,QP,QX,QXB,QXC,QXE,QXEB,Q1,RD,RH,RHE,RX,R1,SD,SE,SH,SHE,SHEZ,SJ,SJP,SW,SWE,SX,SXB,SXE,SXEB,S1,VH,VNG1,VSD,VSD3,VX,VXB,VXE,VXEB,V1,W1
8	15625-ZE1-000	PACKING, OIL FILLER CAP	1	(1)	-	1071798	-----PX,QD,QE,QH,QHC,QHE,QP,QX,QXB,QXE,QXEB,Q1,RD,RH,RHE,RX,R1,SD,SE,SH,SHE,SHEZ,SJ,SJP,SW,SWE,SX,SXB,SXE,SXEB,S1,VH,VNG1,VSD,VSD3,VX,VXB,VXE,VXEB,V1,W1
			1	-	-	-----	-----QXC

Ref. No.	Part No.	Description	Reqd. QTY			Serial No.	Parts catalogue code
			(1)	(2)	(3)		
(8)	15625-ZE1-003	PACKING, OIL FILLER CAP	2	(2)	2	-----	PX/A,PXE8,PXE8/A,PXU,PXU/A,PX26,PX26/A,QAG2,QAG2/A,QD/A,QE/A,QH/A,QHB5,QHE4,QHE4/A,QHP1,QHP1/A,QHQ4,QHQ4/A,QHR,QHR/A,QHR4,QHR4/A,QHZ,QHZ/A,QH26,QH26/A,QKE3,QKE3/A,QKE4,QME2,QME2/A,QMH,QMH/A,QP/A,QSE,QSE/A,QSE2,QSE8,QSE8/A,QT,QT/A,QWA2,QWA4,QWA4/A,QWH2,QWH2/A,QX/A,QXB/A,QXB7,QXB7/A,QXC4,QXC4/A,QXC6,QXC6/A,QXC9,QXC9/A,QXE/A,QXE4,QXE4/A,QXE6,QXE6/A,QXE8,QXE8/A,QXQ4,QXQ4/A,QXU,QXU/A,Q1/A,RD/A,RHE4,RHE4/A,RHQ4,RHQ4/A,RH26,RH26/A,RX/A,RXP,RXP/A,RXQ4,RXQ4/A,RXU,RXU/A,R1/A,SD/A,SE/A,SH/A,SHQ4,SHQ4/A,SJ/A,SJG,SJG/A,SKE1,SMC4,SMC4/A,SMD,SME1,SME1/A,SME6,SME6/A,SMX2,SN,SN/A,SWA4,SWC4,SWC4/A,SX/A,SXB/A,SXB7,SXB7/A,SXE/A,SXEB/A,SXE4,SXE4/A,SXE8,SXE8/A,SXQ4,SXQ4/A,SXU,SXU/A,SX2,S1/A,VAG2,VAG2/A,VD16,VEB6,VKE4,VKX4,VMA4,VME4,VNG1/A,VN17,VN17/A,VPE4,VPE4/A,VPE5,VPE7,VPE7/A,VPX4,VPX4/A,VPX5,VPX7,VPX7/A,VSD/A,VSD3/A,VSD7,VSD7/A,VSH7,VS3,VS37,VS37/A,VWT4,VWT4/A,VX/A,VXB/A,VXB2,VXB6,VXB7,VXB7/A,VXEB/A,VXE4,VXE4/A,VXE6,VXE6/A,VXE7,VXE7/A,VXG,VXP,VXP/A,VXQP,VXQ4/VXQ4/A,VXTB,VXT1,VXT1/A,VXU,VXU/A,VXU1,VXU1/A,VX26,WMA4,WMT8,WMT8/A,WXE8,WXE8/A,W1/A
			2	(2)	-	1071799	-----PX,QD,QE,QH,QHC,QHE,QP,QX,QXB,QXC,QXE,QXEB,Q1,RD,RH,RHE,RX,R1,SD,SE,SH,SHE,SHEZ,SJ,SJP,SW,SWE,SX,SXB,SXE,SXEB,S1,VH,VNG1,VSD,VSD3,VX,VXB,VXE,VXEB,V1,W1
9	16510-ZE2-000	GOVERNOR ASSY.	1	1	1	-----	ES1,ES1/A,PX,PX/A,PXE8,PXE8/A,PXU,PXU/A,PX26,PX26/A,QAG2,QAG2/A,QD,QD/A,QE,QE/A,QH,QH/A,QHB5,QHC,QHE,QHE4,QHE4/A,QHP1,QHP1/A,QHQ4,QHQ4/A,QHR,QHR/A,QHR4,QHR4/A,QHZ,QHZ/A,QH26,QH26/A,QKE3,QKE3/A,QKE4,QME2,QME2/A,QMH,QMH/A,QP,QP/A,QSE,QSE/A,QSE2,QSE8,QSE8/A,QT,QT/A,QWA2,QWA4,QWA4/A,QWH2,QWH2/A,QX,QX/A,QXB,QXB/A,QXB7,QXB7/A,QXC,QXC4,QXC4/A,QXC6,QXC6/A,QXC9,QXC9/A,QXE,QXE/A,QXEB,QXE4,QXE4/A,QXE6,QXE6/A,QXE8,QXE8/A,QXQ4,QXQ4/A,QXU,QXU/A,Q1,Q1/A,RD,RD/A,RH,RHE,RHE4,RHE4/A,RHQ4,RHQ4/A,RH26,RH26/A,RX,RX/A,RXP,RXP/A,RXQ4,RXQ4/A,RXU,RXU/A,R1,R1/A,SD,SD/A,SE,SE/A,SH,SH/A,SHE,SHEZ,SHQ4,SHQ4/A,SJ,SJ/A,SJG,SJG/A,SJP,SKE1,SMC4,SMC4/A,SMD,SME1,SME1/A,SME6,SME6/A,SMX2,SN,SN/A,SW,SWA4,SWC4,SWC4/A,SWE,SX,SX/A,SXB,SXB/A,SXB7,SXB7/A,SXE,SXE/A,SXEB,SXEB/A,SXE4,SXE4/A,SXE8,SXE8/A,SXQ4,SXQ4/A,SXU,SXU/A,SX2,S1,S1/A,VAG2,VAG2/A,VD16,VEB6,VH,VKE4,VKX4,VMA4,VME4,VNG1,VNG1/A,VN17,VN17/A,VPE4,VPE7,VPE7/A,VPX4,VPX7,VPX7/A,VSD,VSD/A,VSD3,VSD3/A,VSD7,VSD7/A,VSH7,VS3,VS37,VS37/A,VWT4,VWT4/A,VX,VX/A,VXB,VXB/A,VXB2,VXB6,VXB7,VXE,VXEB,VXEB/A,VXE4,VXE4/A,VXE6,VXE6/A,VXE7,VXG,VXP,VXP/A,VXQP,VXQ4/VXQ4/A,VXTB,VXT1,VXT1/A,VXU,VXU/A,VXU1,VXU1/A,VX26,V1,WMA4,WMT8,WMT8/A,WXE8,WXE8/A,W1,W1/A
			1	-	-	2134945	-----VPE4/A,VPX4/A,VXB7/A,VXE7/A



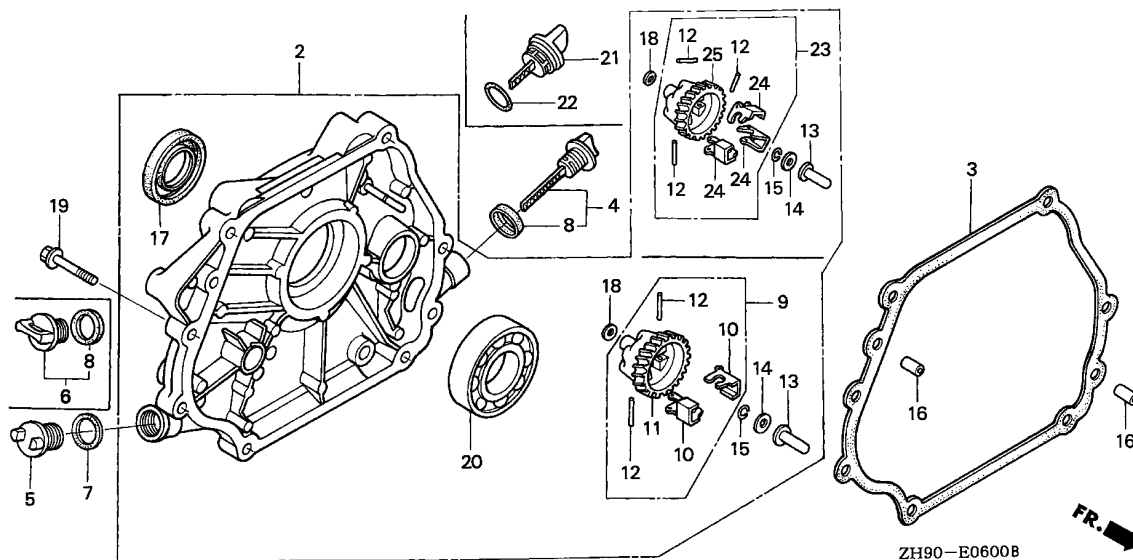

Ref. No.	Part No.	Description	Reqd. QTY			Serial No.	Parts catalogue code
			(1)	(2)	(3)		
10	16511-ZE2-000	WEIGHT, GOVERNOR	2	2	2	-----	ES1,ES1/A,PX,PX/A,PXE8,PXE8/A,PXU,PXU/A,PX26,PX26/A,QAG2,QAG2/A,QD,QD/A,QE,QE/A,QH,QH/A,QHB5,QHC,QHE,QHE4,QHE4/A,QHP1,QHP1/A,QHQ4,QHQ4/A,QHR,QHR/A,QHR4,QHR4/A,QHZ,QHZ/A,QH26,QH26/A,QKE3,QKE3/A,QKE4,QME2,QME2/A,QMH,QMH/A,QP,QP/A,QSE,QSE/A,QSE2,QSE8,QSE8/A,QT,QT/A,QWA2,QWA4,QWA4/A,QWH2,QWH2/A,QX,QX/A,QXB,QXB/A,QXB7,QXB7/A,QXC,QXC4,QXC4/A,QXC6,QXC6/A,QXC9,QXC9/A,QXE,QXE/A,QXEB,QXE4,QXE4/A,QXE6,QXE6/A,QXE8,QXE8/A,QXQ4,QXQ4/A,QXU,QXU/A,Q1,Q1/A,RD,RD/A,RH,RHE,RHE4,RHE4/A,RHQ4,RHQ4/A,RH26,RH26/A,RX,RX/A,RXP,RXP/A,RXQ4,RXQ4/A,RXU,RXU/A,R1,R1/A,SD,SD/A,SE,SE/A,SH,SH/A,SHE,SHEZ,SHQ4,SHQ4/A,SJ,SJ/A,SJG,SJG/A,SJP,SKE1,SMC4,SMC4/A,SMD,SME1,SME1/A,SME6,SME6/A,SMX2,SN,SN/A,SW,SWA4,SWC4,SWC4/A,SWE,SX,SX/A,SXB,SXB/A,SXB7,SXB7/A,SXE,SXE/A,SXEB,SXEB/A,SXE4,SXE4/A,SXE8,SXE8/A,SXQ4,SXQ4/A,SXU,SXU/A,SX2,S1,S1/A,VAG2,VAG2/A,VD16,VEB6,VH,VKE4,VKX4,VMA4,VME4,VNG1,VNG1/A,VN17,VN17/A,VPE4,VPE7,VPE7/A,VPX4,VPX7,VPX7/A,VSD,VSD/A,VSD3,VSD3/A,VSD7,VSD7/A,VSH7,VS3,VS37,VS37/A,VWT4,VWT4/A,VX,VX/A,VXB,VXB/A,VXB2,VXB6,VXB7,VXE,VXEB,VXEB/A,VXE4,VXE4/A,VXE6,VXE6/A,VXE7,VXG,VXP,VXP/A,VXQP,VXQ4,VXQ4/A,VXTB,VXT1,VXT1/A,VXU,VXU/A,VXU1,VXU1/A,VX26,V1,WMA4,WMT8,WMT8/A,WXE8,WXE8/A,W1,W1/A
			2	-	-	-----	2134945 VPE4/A,VPX4/A,VXB7/A,VXE7/A

Ref. No.	Part No.	Description	Reqd. QTY			Serial No.	Parts catalogue code
			(1)	(2)	(3)		
11	16512-ZE2-000	HOLDER, GOVERNOR WEIGHT	1	1	1	-----	ES1,ES1/A,PX,PX/A,PXE8,PXE8/A,PXU,PXU/A,PX26,PX26/A,QAG2,QAG2/A,QD,QD/A,QE,QE/A,QH,QH/A,QHB5,QHC,QHE,QHE4,QHE4/A,QHP1,QHP1/A,QHQ4,QHQ4/A,QHR,QHR/A,QHR4,QHR4/A,QHZ,QHZ/A,QH26,QH26/A,QKE3,QKE3/A,QKE4,QME2,QME2/A,QMH,QMH/A,QP,QP/A,QSE,QSE/A,QSE2,QSE8,QSE8/A,QT,QT/A,QWA2,QWA4,QWA4/A,QWH2,QWH2/A,QX,QX/A,QXB,QXB/A,QXB7,QXB7/A,QXC,QXC4,QXC4/A,QXC6,QXC6/A,QXC9,QXC9/A,QXE,QXE/A,QXEB,QXE4,QXE4/A,QXE6,QXE6/A,QXE8,QXE8/A,QXQ4,QXQ4/A,QXU,QXU/A,Q1,Q1/A,RD,RD/A,RH,RHE,RHE4,RHE4/A,RHQ4,RHQ4/A,RH26,RH26/A,RX,RX/A,RXP,RXP/A,RXQ4,RXQ4/A,RXU,RXU/A,R1,R1/A,SD,SD/A,SE,SE/A,SH,SH/A,SHE,SHEZ,SHQ4,SHQ4/A,SJ,SJ/A,SJG,SJG/A,SJP,SKE1,SMC4,SMC4/A,SMD,SME1,SME1/A,SME6,SME6/A,SMX2,SN,SN/A,SW,SWA4,SWC4,SWC4/A,SWE,SX,SX/A,SXB,SXB/A,SXB7,SXB7/A,SXE,SXE/A,SXEB,SXEB/A,SXE4,SXE4/A,SXE8,SXE8/A,SXQ4,SXQ4/A,SXU,SXU/A,SX2,S1,S1/A,VAG2,VAG2/A,VD16,VEB6,VH,VKE4,VKX4,VMA4,VME4,VNG1,VNG1/A,VN17,VN17/A,VPE4,VPE7,VPE7/A,VPX4,VPX7,VPX7/A,VSD,VSD/A,VSD3,VSD3/A,VSD7,VSD7/A,VSH7,VS3,VS37,VS37/A,VWT4,VWT4/A,VX,VX/A,VXB,VXB/A,VXB2,VXB6,VXB7,VXE,VXEB,VXEB/A,VXE4,VXE4/A,VXE6,VXE6/A,VXE7,VXG,VXP,VXP/A,VXQP,VXQ4,VXQ4/A,VXTB,VXT1,VXT1/A,VXU,VXU/A,VXU1,VXU1/A,VX26,V1,WMA4,WMT8,WMT8/A,WXE8,WXE8/A,W1,W1/A
			1	-	-	-----	2134945 VPE4/A,VPX4/A,VXB7/A,VXE7/A
12	16513-ZE2-000	PIN, GOVERNOR WEIGHT	2	2	2	-----	ES1,ES1/A,PX,PX/A,PXE8,PXE8/A,PXU,PXU/A,PX26,PX26/A,QAG2,QAG2/A,QD,QD/A,QE,QE/A,QH,QH/A,QHB5,QHC,QHE,QHE4,QHE4/A,QHP1,QHP1/A,QHQ4,QHQ4/A,QHR,QHR/A,QHR4,QHR4/A,QHZ,QHZ/A,QH26,QH26/A,QKE3,QKE3/A,QKE4,QME2,QME2/A,QMH,QMH/A,QP,QP/A,QSE,QSE/A,QSE2,QSE8,QSE8/A,QT,QT/A,QWA2,QWA4,QWA4/A,QWH2,QWH2/A,QX,QX/A,QXB,QXB/A,QXB7,QXB7/A,QXC,QXC4,QXC4/A,QXC6,QXC6/A,QXC9,QXC9/A,QXE,QXE/A,QXEB,QXE4,QXE4/A,QXE6,QXE6/A,QXE8,QXE8/A,QXQ4,QXQ4/A,QXU,QXU/A,Q1,Q1/A,RD,RD/A,RH,RHE,RHE4,RHE4/A,RHQ4,RHQ4/A,RH26,RH26/A,RX,RX/A,RXP,RXP/A,RXQ4,RXQ4/A,RXU,RXU/A,R1,R1/A,SD,SD/A,SE,SE/A,SH,SH/A,SHE,SHEZ,SHQ4,SHQ4/A,SJ,SJ/A,SJG,SJG/A,SJP,SKE1,SMC4,SMC4/A,SMD,SME1,SME1/A,SME6,SME6/A,SMX2,SN,SN/A,SW,SWA4,SWC4,SWC4/A,SWE,SX,SX/A,SXB,SXB/A,SXB7,SXB7/A,SXE,SXE/A,SXEB,SXEB/A,SXE4,SXE4/A,SXE8,SXE8/A,SXQ4,SXQ4/A,SXU,SXU/A,SX2,S1,S1/A,VAG2,VAG2/A,VD16,VEB6,VH,VKE4,VKX4,VMA4,VME4,VNG1,VNG1/A,VN17,VN17/A,VPE4,VPE7,VPE7/A,VPX4,VPX7,VPX7/A,VSD,VSD/A,VSD3,VSD3/A,VSD7,VSD7/A,VSH7,VS3,VS37,VS37/A,VWT4,VWT4/A,VX,VX/A,VXB,VXB/A,VXB2,VXB6,VXB7,VXE,VXEB,VXEB/A,VXE4,VXE4/A,VXE6,VXE6/A,VXE7,VXG,VXP,VXP/A,VXQP,VXQ4,VXQ4/A,VXTB,VXT1,VXT1/A,VXU,VXU/A,VXU1,VXU1/A,VX26,V1,WMA4,WMT8,WMT8/A,WXE8,WXE8/A,W1,W1/A
			2	-	-	-----	2134945 VPE4/A,VPX4/A,VXB7/A,VXE7/A
			2	-	-	-----	SWA4,VMA4,VME4,VS3,WMA4
			3	-	-	-----	VPE5,VPX5
			3	-	-	-----	VPE4/A,VPX4/A,VXB7/A,VXE7/A
13	16531-ZE2-000	SLIDER, GOVERNOR	1	1	-	-----	1832354 ES1,PX,PXE8,PXU,PX26,QAG2,QD,QE,QH,QHE4,QHP1,QHQ4,QHR,QHR4,QHZ,QH26,QKE3,QME2,QMH,QP,QSE,QSE8,QT,QWA4,QWH2,QX,QXB,QXC4,QXC6,QXC9,QXE,QXE4,QXE6,QXE8,QXQ4,QXU,Q1,RD,RHE4,RHQ4,RH26,RX,RXQ4,RXU,R1,SD,SE,SH,SHQ4,SJG,SMC4,SME1,SME6,SN,SWC4,SX,SXB,SXE,SXEB,SXE4,SXE8,SXQ4,SXU,S1,VNG1,VN17,VPE4,VPE7,VPX4,VSD,VSD3,VWT4,VX,VXB,VXEB,VXE4,VXE6,VXQ4,VXT1,VXU,VXU1,WMT8,WXE8,W1



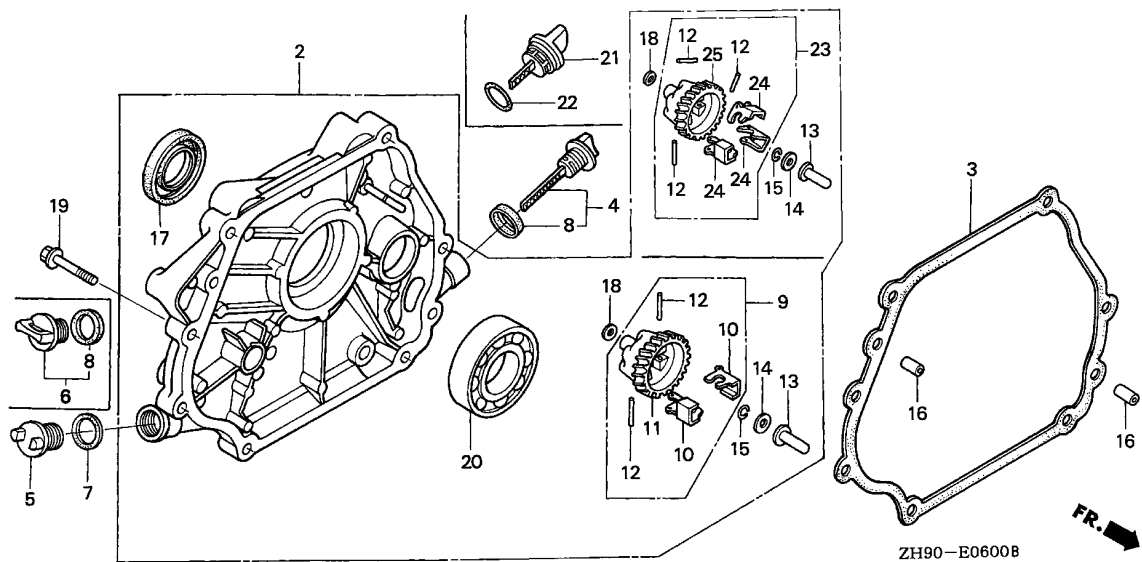

Ref. No.	Part No.	Description	Reqd. QTY			Serial No.	Parts catalogue code
			(1)	(2)	(3)		
13)	16531-Z0A-000	SLIDER, GOVERNOR	1	1	1	-----	ES1/A,PX/A,PXE8/A,PXU/A,PX26/A,QAG2/A,QD/A,QE/A,QH/A,QHB5,QHC,QHE,QHE4/A,QHP1/A,QHQ4/A,QHR/A,QHR4/A,QHZ/A,QH26/A,QKE3/A,QKE4,QME2/A,QMH/A,QP/A,QSE/A,QSE2,QSE8/A,QT/A,QWA2,QWA4/A,QWH2/A,QX/A,QXB/A,QXB7,QXB7/A,QXC,QXC4/A,QXC6/A,QXC9/A,QXE/A,QXEB,QXE4/A,QXE6/A,QXE8/A,QXQ4/A,QXU/A,Q1/A,RD/A,RH,RHE,RHE4/A,RHQ4/A,RH26/A,RX/A,RXP,RXP/A,RXQ4/A,RXU/A,R1/A,SD/A,SE/A,SH/A,SHE,SHEZ,SHQ4/A,SJ,SJ/A,SJG/A,SJP,SKE1,SMC4/A,SMD,SME1/A,SME6/A,SMX2,SN/A,SW,SWA4,SWC4/A,SWE,SX/A,SXB/A,SXB7,SXB7/A,SXE/A,SXEB/A,SXE4/A,SXE8/A,SXQ4/A,SXU/A,SX2,S1/A,VAG2,VAG2/A,VD16,VEB6,VH,VKE4,VKX4,VMA4,VME4,VNG1/A,VN17/A,VPE4/A,VPE5,VPE7/A,VPX4/A,VPX5,VPX7,VPX7/A,VSD/A,VSD3/A,VSD7,VSD7/A,VSH7,VS3,VS37,VS37/A,VWT4/A,VX/A,VXB/A,VXB2,VXB6,VXB7,VXB7/A,VXE,VXEB/A,VXE4/A,VXE6/A,VXE7,VXE7/A,VXG,VXP,VXP/A,VXQP,VXQ4/A,VXTB,VXT1/A,VXU/A,VXU1/A,VX26,V1,WMA4,WMT8/A,WXE8/A,W1/A
			1	1	-	1832355 -----	ES1,PX,PXE8,PXU,PX26,QAG2,QD,QE,QH,QHE4,QHP1,QHQ4,QHR,QHR4,QHZ,QH26,QKE3,QME2,QMH,QP,QSE,QSE8,QT,QWA4,QWH2,QX,QXB,QXC4,QXC6,QXC9,QXE,QXE4,QXE6,QXE8,QXQ4,QXU,Q1,RD,RHE4,RHQ4,RH26,RX,RXP,RXQ4,RXU,R1,SD,SE,SH,SHQ4,SJG,SMC4,SME1,SME6,SN,SWC4,SX,SXB,SXE,SXEB,SXE4,SXE8,SXQ4,SXU,S1,VNG1,VN17,VPE4,VPE7,VPX4,VSD,VSD3,VSD7,VSH7,VS3,VS37,VWT4,VX,VXB,VXB6,VXB7,VXB7/A,VXE,VXEB/A,VXE4/A,VXE6/A,VXE7,VXE7/A,VXG,VXP,VXP/A,VXQP,VXQ4/A,VXTB,VXT1,VXU,VXU1,WMT8,WXE8,W1

Ref. No.	Part No.	Description	Reqd. QTY			Serial No.	Parts catalogue code
			(1)	(2)	(3)		
14	90473-147-000	WASHER, 6X16	1	1	-	1065525	Q1,R1,SJ,SJP,S1,V1,W1
			1	-	-	1064745	PX,QD,QE,QH,QHC,QHE,QP,QX,QXB,QXC,QXE,QXEB,RD,RH,RHE,RX,SD,SE,SH SHE,SHEZ,SW,SWE,SX,SXB,SXE,SXEB,VH,VNG1,VSD,VSD3,VX,VXB,VXE,VXEB
			1	-	-	1073307	SN
			1	1	-	1832355	ES1,PX,PXE8,PXU,PX26,QAG2,QD,QE,QH,QHE4,QHP1,QHQ4,QHR,QHR4,QHZ QH26,QKE3,QME2,QMH,QP,QSE,QSE8,QT,QWA4,QWH2,QX,QXB,QXC4,QXC6,QXC9 QXE,QXE4,QXE6,QXE8,QXQ4,QXU,Q1,RD,RHE4,RHQ4,RH26,RX,RXQ4,RXU,R1 SD,SE,SH,SHQ4,SJG,SMC4,SME1,SME6,SN,SWC4,SX,SXB,SXE,SXEB,SXE4 SXE8,SXQ4,SXU,S1,VNG1,VN17,VPE4,VPE7,VPX4,VSD,VSD3,VWT4,VX,VXB VXEB,VXE4,VXE6,VXQ4,VXT1,VXU,VXU1,WMT8,WXE8,W1
1	-	-		RXP,VPE5,VPX5,VXP			
15	90602-ZE1-000	CLIP, GOVERNOR HOLDER	1	-	-	2134946	VPE4/A,VPX4/A,VXB7/A,VXE7/A
			1	1	1		ES1,ES1/A,PX,PX/A,PXE8,PXE8/A,PXU,PXU/A,PX26,PX26/A,QAG2,QAG2/A QD,QD/A,QE,QE/A,QH,QH/A,QHB5,QHC,QHE,QHE4,QHE4/A,QHP1,QHP1/A,QHQ4 QHQ4/A,QHR,QHR/A,QHR4,QHR4/A,QHZ,QHZ/A,QH26,QH26/A,QKE3,QKE3/A QKE4,QME2,QME2/A,QMH,QMH/A,QP,QP/A,QSE,QSE/A,QSE2,QSE8,QSE8/A,QT QT/A,QWA2,QWA4,QWA4/A,QWH2,QWH2/A,QX,QX/A,QXB,QXB/A,QXB7,QXB7/A QXC,QXC4,QXC4/A,QXC6,QXC6/A,QXC9,QXC9/A,QXE,QXE/A,QXEB,QXE4 QXE4/A,QXE6,QXE6/A,QXE8,QXE8/A,QXQ4,QXQ4/A,QXU,QXU/A,Q1,Q1/A,RD RD/A,RH,RHE,RHE4,RHE4/A,RHQ4,RHQ4/A,RH26,RH26/A,RX,RX/A,RXP,RXP/A RXQ4,RXQ4/A,RXU,RXU/A,R1,R1/A,SD,SD/A,SE,SE/A,SH,SH/A,SHE,SHEZ SHQ4,SHQ4/A,SJ,SJ/A,SJG,SJG/A,SJP,SKE1,SMC4,SMC4/A,SMD,SME1 SME1/A,SME6,SME6/A,SMX2,SN,SN/A,SW,SWA4,SWC4,SWC4/A,SWE,SX,SX/A SXB,SXB/A,SXB7,SXB7/A,SXE,SXE/A,SXEB,SXEB/A,SXE4,SXE4/A,SXE8 SXE8/A,SXQ4,SXQ4/A,SXU,SXU/A,SX2,S1,S1/A,VAG2,VAG2/A,VD16,VEB6,VH VKE4,VKX4,VMA4,VME4,VNG1,VNG1/A,VN17,VN17/A,VPE4,VPE4/A,VPE5,VPE7 VPE7/A,VPX4,VPX4/A,VPX5,VPX7,VPX7/A,VSD,VSD/A,VSD3,VSD3/A,VSD7 VSD7/A,VSH7,VS3,VS37,VS37/A,VWT4,VWT4/A,VX,VX/A,VXB,VXB/A,VXB2 VXB6,VXB7,VXB7/A,VXE,VXEB,VXEB/A,VXE4,VXE4/A,VXE6,VXE6/A,VXE7 VXE7/A,VXG,VXP,VXP/A,VXQP,VXQ4,VXQ4/A,VXTB,VXT1,VXT1/A,VXU,VXU/A VXU1,VXU1/A,VX26,V1,WMA4,WMT8,WMT8/A,WXE8,WXE8/A,W1,W1/A
16	90701-HC4-000	DOWEL PIN, 8X12	2	2	2		ES1,ES1/A,PX,PX/A,PXE8,PXE8/A,PXU,PXU/A,PX26,PX26/A,QAG2,QAG2/A QD,QD/A,QE,QE/A,QH,QH/A,QHB5,QHC,QHE,QHE4,QHE4/A,QHP1,QHP1/A,QHQ4 QHQ4/A,QHR,QHR/A,QHR4,QHR4/A,QHZ,QHZ/A,QH26,QH26/A,QKE3,QKE3/A QKE4,QME2,QME2/A,QMH,QMH/A,QP,QP/A,QSE,QSE/A,QSE2,QSE8,QSE8/A,QT QT/A,QWA2,QWA4,QWA4/A,QWH2,QWH2/A,QX,QX/A,QXB,QXB/A,QXB7,QXB7/A QXC,QXC4,QXC4/A,QXC6,QXC6/A,QXC9,QXC9/A,QXE,QXE/A,QXEB,QXE4 QXE4/A,QXE6,QXE6/A,QXE8,QXE8/A,QXQ4,QXQ4/A,QXU,QXU/A,Q1,Q1/A,RD RD/A,RH,RHE,RHE4,RHE4/A,RHQ4,RHQ4/A,RH26,RH26/A,RX,RX/A,RXP,RXP/A RXQ4,RXQ4/A,RXU,RXU/A,R1,R1/A,SD,SD/A,SE,SE/A,SH,SH/A,SHE,SHEZ SHQ4,SHQ4/A,SJ,SJ/A,SJG,SJG/A,SJP,SKE1,SMC4,SMC4/A,SMD,SME1 SME1/A,SME6,SME6/A,SMX2,SN,SN/A,SW,SWA4,SWC4,SWC4/A,SWE,SX,SX/A SXB,SXB/A,SXB7,SXB7/A,SXE,SXE/A,SXEB,SXEB/A,SXE4,SXE4/A,SXE8 SXE8/A,SXQ4,SXQ4/A,SXU,SXU/A,SX2,S1,S1/A,VAG2,VAG2/A,VD16,VEB6,VH VKE4,VKX4,VMA4,VME4,VNG1,VNG1/A,VN17,VN17/A,VPE4,VPE4/A,VPE5,VPE7 VPE7/A,VPX4,VPX4/A,VPX5,VPX7,VPX7/A,VSD,VSD/A,VSD3,VSD3/A,VSD7 VSD7/A,VSH7,VS3,VS37,VS37/A,VWT4,VWT4/A,VX,VX/A,VXB,VXB/A,VXB2 VXB6,VXB7,VXB7/A,VXE,VXEB,VXEB/A,VXE4,VXE4/A,VXE6,VXE6/A,VXE7 VXE7/A,VXG,VXP,VXP/A,VXQP,VXQ4,VXQ4/A,VXTB,VXT1,VXT1/A,VXU,VXU/A VXU1,VXU1/A,VX26,V1,WMA4,WMT8,WMT8/A,WXE8,WXE8/A,W1,W1/A
			1	1	-		WMA4,WMT8,WMT8/A,WXE8,WXE8/A,W1,W1/A



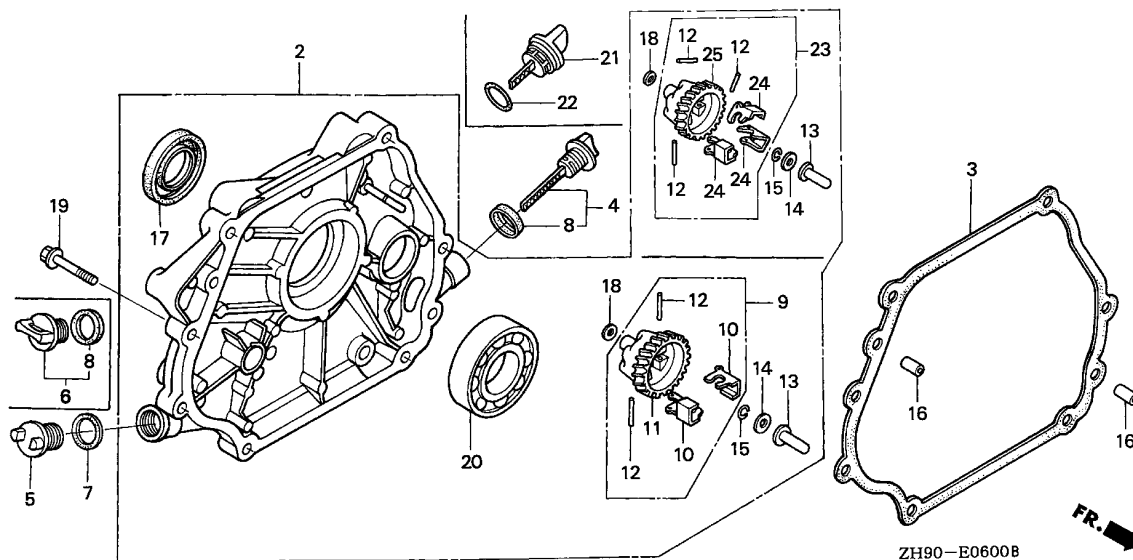

Ref. No.	Part No.	Description	Reqd. QTY			Serial No.	Parts catalogue code
			(1)	(2)	(3)		
17)	91201-890-003	OIL SEAL, 30X46X8	1	1	1	-----	ES1,ES1/A,PX,PX/A,PXE8,PXE8/A,PXU,PXU/A,PX26,PX26/A,QAG2,QAG2/A,QD,QD/A,QE,QE/A,QH,QH/A,QHB5,QHC,QHE,QHE4,QHE4/A,QHP1,QHP1/A,QHQ4,QHQ4/A,QHR,QHR/A,QHR4,QHR4/A,QHZ,QHZ/A,QH26,QH26/A,QKE3,QKE3/A,QKE4,QME2,QME2/A,QMH,QMH/A,QP,QP/A,QSE,QSE/A,QSE2,QSE8,QSE8/A,QT,QT/A,QWA2,QWA4,QWA4/A,QWH2,QWH2/A,QX,QX/A,QXB,QXB/A,QXB7,QXB7/A,QXC,QXC4,QXC4/A,QXC6,QXC6/A,QXC9,QXC9/A,QXE,QXE/A,QXEB,QXE4,QXE4/A,QXE6,QXE6/A,QXE8,QXE8/A,QXQ4,QXQ4/A,QXU,QXU/A,Q1,Q1/A,RD,RD/A,RH,RHE,RHE4,RHE4/A,RHQ4,RHQ4/A,RH26,RH26/A,RX,RX/A,RXP,RXP/A,RXQ4,RXQ4/A,RXU,RXU/A,R1,R1/A,SD,SD/A,SE,SE/A,SH,SH/A,SHE,SHEZ,SHQ4,SHQ4/A,SJ,SJ/A,SJG,SJG/A,SJP,SKE1,SMC4,SMC4/A,SMD,SME1,SME1/A,SME6,SME6/A,SMX2,SN,SN/A,SW,SWA4,SWC4,SWC4/A,SWE,SX,SX/A,SXB,SXB/A,SXB7,SXB7/A,SXE,SXE/A,SXEB,SXEB/A,SXE4,SXE4/A,SXE8,SXE8/A,SXQ4,SXQ4/A,SXU,SXU/A,SX2,S1,S1/A,VAG2,VAG2/A,VD16,VEB6,VH,VKE4,VKX4,VMA4,VME4,VNG1,VNG1/A,VN17,VN17/A,VPE4,VPE4/A,VPE5,VPE7,VPE7/A,VPX4,VPX4/A,VPX5,VPX7,VPX7/A,VSD,VSD/A,VSD3,VSD3/A,VSD7,VSD7/A,VSH7,VS3,VS37,VS37/A,VWT4,VWT4/A,VX,VX/A,VXB,VXB/A,VXB2,VXB6,VXB7,VXB7/A,VXE,VXEB,VXEB/A,VXE4,VXE4/A,VXE6,VXE6/A,VXE7,VXE7/A,VXG,VXP,VXP/A,VXQP,VXQ4,VXQ4/A,VXTB,VXT1,VXT1/A,VXU,VXU/A,VXU1,VXU1/A,VX26,V1

Ref. No.	Part No.	Description	Reqd. QTY			Serial No.	Parts catalogue code
			(1)	(2)	(3)		
18	94101-06800	WASHER, PLAIN, 6MM	1	1	1	-----	ES1, ES1/A, PX, PX/A, PXE8, PXE8/A, PXU, PXU/A, PX26, PX26/A, QAG2, QAG2/A, QD, QD/A, QE, QE/A, QH, QH/A, QHB5, QHC, QHE, QHE4, QHE4/A, QHP1, QHP1/A, QHQ4, QHQ4/A, QHR, QHR/A, QHR4, QHR4/A, QHZ, QHZ/A, QH26, QH26/A, QKE3, QKE3/A, QKE4, QME2, QME2/A, QMH, QMH/A, QP, QP/A, QSE, QSE/A, QSE2, QSE8, QSE8/A, QT, QT/A, QWA2, QWA4, QWA4/A, QWH2, QWH2/A, QX, QX/A, QXB, QXB/A, QXB7, QXB7/A, QXC, QXC4, QXC4/A, QXC6, QXC6/A, QXC9, QXC9/A, QXE, QXE/A, QXE6, QXE6/A, QXE8, QXE8/A, QXQ4, QXQ4/A, Q1, Q1/A, RD, RD/A, RH, RHE, RHE4, RHE4/A, RHQ4, RHQ4/A, RH26, RH26/A, RX, RX/A, RXP, RXP/A, RXQ4, RXQ4/A, RXU, RXU/A, R1, R1/A, SD, SD/A, SE, SE/A, SH, SH/A, SHE, SHEZ, SHQ4, SHQ4/A, SJ, SJ/A, SJG, SJG/A, SJP, SKE1, SMC4, SMC4/A, SMD, SME1, SME1/A, SME6, SME6/A, SMX2, SN, SN/A, SW, SWA4, SWC4, SWC4/A, SWE, SX, SX/A, SXB, SXB/A, SXB7, SXB7/A, SXE, SXE/A, SXEB, SXEB/A, SXE4, SXE4/A, SXE8, SXE8/A, SXQ4, SXQ4/A, SXU, SXU/A, SX2, S1, S1/A, VAG2, VAG2/A, VD16, VEB6, VH, VKE4, VKX4, VMA4, VME4, VNG1, VNG1/A, VN17, VN17/A, VPE4, VPE4/A, VPE5, VPE7, VPE7/A, VPX4, VPX4/A, VPX5, VPX7, VPX7/A, VSD, VSD/A, VSD3, VSD3/A, VSD7, VSD7/A, VSH7, VS3, VS37, VS37/A, VWT4, VWT4/A, VX, VX/A, VXB, VXB/A, VXB2, VXB6, VXB7, VXB7/A, VXE, VXE6, VXE6/A, VXE7, VXE7/A, VXE8, VXE8/A, VXE9, VXE9/A, VXG, VXP, VXP/A, VXQ4, VXQ4/A, VXTB, VXT1, VXT1/A, VXU, VXU/A, VXU1, VXU1/A, VX26, VMA4, WMT8, WMT8/A, WXE8, WXE8/A, W1, W1/A
19	95900-08035-00	BOLT, FLANGE, 8X35	7	7	-	-----	QD, QE, QH, QHC, QHE, QP, QX, QXB, QXC, QXE, QXE6, QXE6/A, QXE8, QXE8/A, QXU, Q1, RD, RH, RHE, RX, RXU, SD, SE, SH, SHE, SHEZ, SJ, SJP, SW, SWE, SX, SXB, SXE, SXEB, SXE8, SXU, S1, VH, VNG1, VX, VXB, VXE, VXE6, V1, W1
	95701-08035-00	7	7	7	-----	ES1, ES1/A, PX, PX/A, PXE8, PXE8/A, PXU, PXU/A, PX26, PX26/A, QAG2, QAG2/A, QD/A, QE/A, QH/A, QHB5, QHE4, QHE4/A, QHP1, QHP1/A, QHQ4, QHQ4/A, QHR, QHR/A, QHR4, QHR4/A, QHZ, QHZ/A, QH26, QH26/A, QKE3, QKE3/A, QKE4, QME2, QME2/A, QMH, QMH/A, QP/A, QSE, QSE/A, QSE2, QSE8, QSE8/A, QT, QT/A, QWA2, QWA4, QWA4/A, QWH2, QWH2/A, QX/A, QXB/A, QXB7, QXB7/A, QXC4, QXC4/A, QXC6, QXC6/A, QXC9, QXC9/A, QXE/A, QXE4, QXE4/A, QXE6, QXE6/A, QXE8/A, QXQ4, QXQ4/A, QXU/A, Q1/A, RD/A, RHE4, RHE4/A, RHQ4, RHQ4/A, RH26, RH26/A, RX/A, RXP, RXP/A, RXQ4, RXQ4/A, RXU/A, R1, R1/A, SD/A, SE/A, SH/A, SHQ4, SHQ4/A, SJ/A, SJG, SJG/A, SKE1, SMC4, SMC4/A, SMD, SME1, SME1/A, SME6, SME6/A, SMX2, SN, SN/A, SWA4, SWC4, SWC4/A, SX/A, SXB/A, SXB7, SXB7/A, SXE/A, SXEB/A, SXE4, SXE4/A, SXE8/A, SXQ4, SXQ4/A, SXU/A, SX2, S1/A, VAG2, VAG2/A, VD16, VEB6, VKE4, VKX4, VMA4, VME4, VNG1/A, VN17, VN17/A, VPE4, VPE4/A, VPE5, VPE7, VPE7/A, VPX4, VPX4/A, VPX5, VPX7, VPX7/A, VSD, VSD/A, VSD3, VSD3/A, VSD7, VSD7/A, VSH7, VS3, VS37, VS37/A, VWT4, VWT4/A, VX/A, VXB/A, VXB2, VXB6, VXB7, VXB7/A, VXE6, VXE6/A, VXE7, VXE7/A, VXG, VXP, VXP/A, VXQ4, VXQ4/A, VXTB, VXT1, VXT1/A, VXU, VXU/A, VXU1, VXU1/A, VX26, VMA4, WMT8, WMT8/A, WXE8, WXE8/A, W1/A
20	96100-62060-00	BEARING, RADIAL BALL, 6206 ..	1	1	1	-----	ES1, ES1/A, PX, PX/A, PXE8, PXE8/A, PXU, PXU/A, PX26, PX26/A, QAG2, QAG2/A, QD, QD/A, QE, QE/A, QH, QH/A, QHB5, QHC, QHE, QHE4, QHE4/A, QHP1, QHP1/A, QHQ4, QHQ4/A, QHR, QHR/A, QHR4, QHR4/A, QHZ, QHZ/A, QH26, QH26/A, QKE3, QKE3/A, QKE4, QME2, QME2/A, QMH, QMH/A, QP, QP/A, QSE, QSE/A, QSE2, QSE8, QSE8/A, QT, QT/A, QWA2, QWA4, QWA4/A, QWH2, QWH2/A, QX, QX/A, QXB, QXB/A, QXB7, QXB7/A, QXC, QXC4, QXC4/A, QXC6, QXC6/A, QXC9, QXC9/A, QXE, QXE/A, QXE6, QXE6/A, QXE8, QXE8/A, QXQ4, QXQ4/A, QXU, QXU/A, Q1, Q1/A, RD, RD/A, RH, RHE, RHE4, RHE4/A, RHQ4, RHQ4/A, RH26, RH26/A, RX, RX/A, RXP, RXP/A, RXQ4, RXQ4/A, RXU, RXU/A, R1, R1/A, SD, SD/A, SE, SE/A, SH, SH/A, SHE, SHEZ, SHQ4, SHQ4/A, SJ, SJ/A, SJG, SJG/A, SJP, SKE1, SMC4, SMC4/A, SMD, SME1, SME1/A, SME6, SME6/A, SMX2, SN, SN/A, SW, SWA4, SWC4, SWC4/A, SWE, SX, SX/A, SXB, SXB/A, SXB7, SXB7/A, SXE, SXE/A, SXEB, SXEB/A, SXE4, SXE4/A, SXE8, SXE8/A, SXQ4, SXQ4/A, SXU, SXU/A, SX2, S1, S1/A, VAG2, VAG2/A, VD16, VEB6, VH, VKE4, VKX4, VMA4, VME4, VNG1, VNG1/A, VN17, VN17/A, VPE4, VPE4/A, VPE5, VPE7, VPE7/A, VPX4, VPX4/A, VPX5, VPX7, VPX7/A, VSD, VSD/A, VSD3, VSD3/A, VSD7, VSD7/A, VSH7, VS3, VS37, VS37/A, VWT4, VWT4/A, VX, VX/A, VXB, VXB/A, VXB2, VXB6, VXB7, VXB7/A, VXE, VXE6, VXE6/A, VXE7, VXE7/A, VXG, VXP, VXP/A, VXQ4, VXQ4/A, VXTB, VXT1, VXT1/A, VXU, VXU/A, VXU1, VXU1/A, VX26, V1, VMA4, WMT8, WMT8/A, WXE8, WXE8/A, W1, W1/A



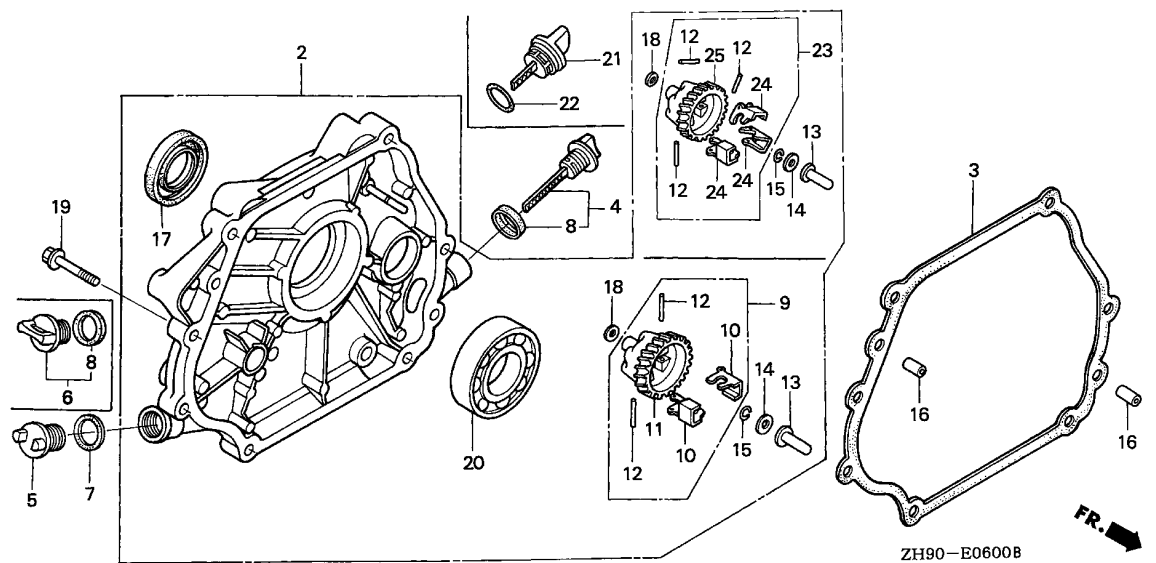

Ref. No.	Part No.	Description	Reqd. QTY			Serial No.	Parts catalogue code
			(1)	(2)	(3)		
21	15620-ZE2-700	CAP, OIL FILLER	1	-	-	ES1,ES1/A	
22	91301-805-000	O-RING, 26X2.7	1	-	-	ES1,ES1/A	
23	16510-ZE3-000	GOVERNOR ASSY.	1	-	-	VPE5,VPX5	
24	16511-ZE8-000	WEIGHT, GOVERNOR	1	-	-	2134946	VPE4/A,VPX4/A,VXB7/A,VXE7/A
			3	-	-		VPE5,VPX5
25	16512-ZE3-000	HOLDER, GOVERNOR WEIGHT	3	-	-	2134946	VPE4/A,VPX4/A,VXB7/A,VXE7/A
			1	-	-		VPE5,VPX5
			1	-	-	2134946	VPE4/A,VPX4/A,VXB7/A,VXE7/A

E-6-1

CRANKCASE COVER(2)

F16

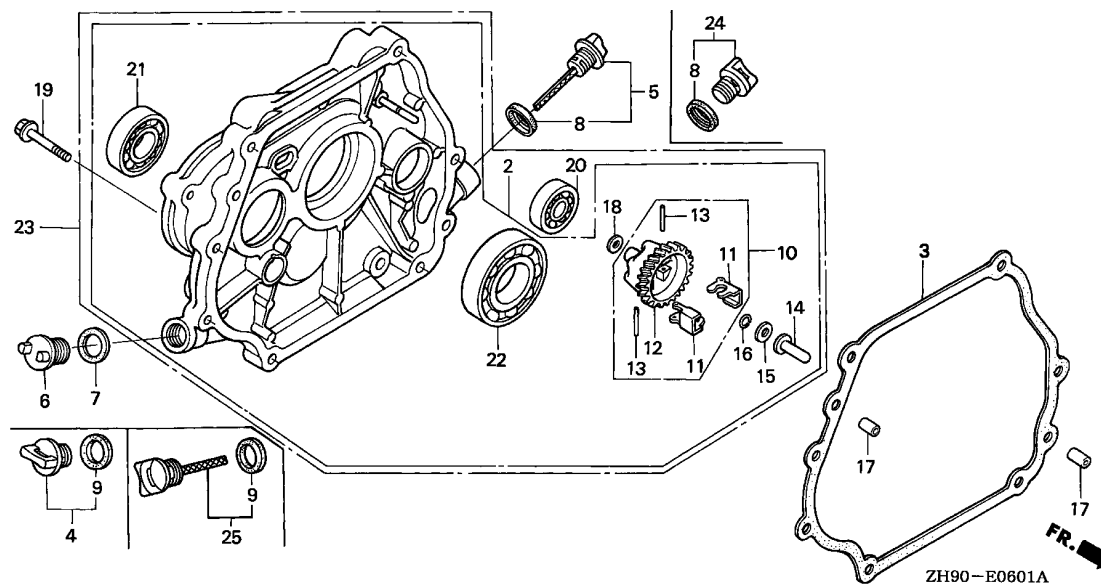

Ref. No.	L.O.N.	(Relative ref. Number) Description	F.R.T.
3	1101F9	PACKING, CRANKCASE COVER(A) (11)	0.3
12	1161C6	HOLDER, GOVERNOR WEIGHT(A)	0.4
14	1161B6	SLIDER, GOVERNOR	0.3
20	1101F5	BEARING, BALANCER WEIGHT :REAR	0.4
21	2141A7	BEARING, POWER TAKE OFF SHAFT :FRONT	0.4
22	1101A6	BEARING, CRANKSHAFT :REAR	0.4
23	1101G0	COVER, CRANKCASE(A)	0.3

Ref. No.	Part No.	Description	Reqd. QTY			Serial No.	Parts catalogue code
			(1)	(2)	(3)		
2	11300-ZE2-610	COVER ASSY., CRANKCASE	1	1	-	1832354	LH,LHE,LJ,LJC,LJG,LT,LW,LX,LXE,LXE8,LXQ4,LXU,L1
	11300-ZE2-611		1	-	-		LHB1,LHB3,LHQ4,LWD,LXZ,LX16
	11300-ZE2-612		1	1	-	1832355	LH,LHE,LJ,LJC,LJG,LT,LW,LX,LXE,LXE8,LXQ4,LXU,L1
3	11381-ZE2-801	PACKING, CASE COVER	1	(1)	-		LH,LH/A,LHB1,LHB3,LHB5,LHE,LHE/A,LHQ4,LJ,LJ/A,LJC,LJC/A,LJG,LJG/A,LSS,LT,LT/A,LTJ,LW,LW/A,LWD,LWD1,LWD1/A,LX,LX/A,LXE,LXE/A,LXE8,LXE8/A,LXQ4,LXQ4/A,LXU,LXU/A,LXZ,LX16,L1,L1/A
4	15600-ZG4-003	CAP ASSY., OIL FILLER	1	1	-		LH/A,LHB1,LHB3,LHB5,LHE/A,LHQ4,LJ/A,LJC,LJC/A,LJG,LJG/A,LSS,LT,LT/A,LTJ,LW/A,LX/A,LXE,LXE/A,LXE8,LXE8/A,LXQ4,LXQ4/A,LXU,LXU/A,LX16,L1/A
5	15600-735-003	CAP ASSY., OIL FILLER	1	1	-	1071799	LH,LHE,LJ,LW,LWD,LX,LXZ,L1
			1	(1)	-		LH,LH/A,LHB1,LHB3,LHB5,LHE,LHE/A,LHQ4,LJ,LJ/A,LJC,LJC/A,LJG,LJG/A,LSS,LT,LT/A,LTJ,LW,LW/A,LWD,LX,LX/A,LXE,LXE/A,LXE8,LXE8/A,LXQ4,LXQ4/A,LXU,LXU/A,LXZ,LX16,L1,L1/A
6	15620-ZG4-910	CAP, OIL FILLER	1	1	-	1071798	LH,LHE,LJ,LW,LWD,LX,LXZ,L1
7	15621-896-010	PACKING, OIL FILLER CAP	1	1	-	1071798	LH,LHE,LJ,LW,LWD,LX,LXZ,L1
8	15625-ZE1-003	PACKING, OIL FILLER CAP	1	(1)	-		LH,LH/A,LHB1,LHB3,LHB5,LHE,LHE/A,LHQ4,LJ,LJ/A,LJC,LJC/A,LJG,LJG/A,LSS,LT,LT/A,LTJ,LW,LW/A,LWD,LWD1,LWD1/A,LX,LX/A,LXE,LXE/A,LXE8,LXE8/A,LXQ4,LXQ4/A,LXU,LXU/A,LXZ,LX16,L1,L1/A
9	15625-ZE1-003	PACKING, OIL FILLER CAP	1	(1)	-		LH/A,LHB1,LHB3,LHB5,LHE/A,LHQ4,LJ/A,LJC,LJC/A,LJG,LJG/A,LSS,LT,LT/A,LTJ,LW/A,LWD1,LWD1/A,LX/A,LXE,LXE/A,LXE8,LXE8/A,LXQ4,LXQ4/A,LXU,LXU/A,LX16,L1/A
10	16510-ZE2-000	GOVERNOR ASSY.	1	(1)	-	1071799	LH,LHE,LJ,LW,LWD,LX,LXZ,L1
	16510-ZE2-811		1	(1)	-		LH,LH/A,LHB1,LHB3,LHB5,LHE,LHE/A,LHQ4,LJ,LJ/A,LJC,LJC/A,LJG,LJG/A,LT,LT/A,LW,LW/A,LWD,LX,LX/A,LXE,LXE/A,LXE8,LXE8/A,LXQ4,LXQ4/A,LXU,LXU/A,LXZ,LX16,L1,L1/A
			1	-	-		LSS,LTJ,LWD1,LWD1/A



E-6-1

CRANKCASE COVER(2)

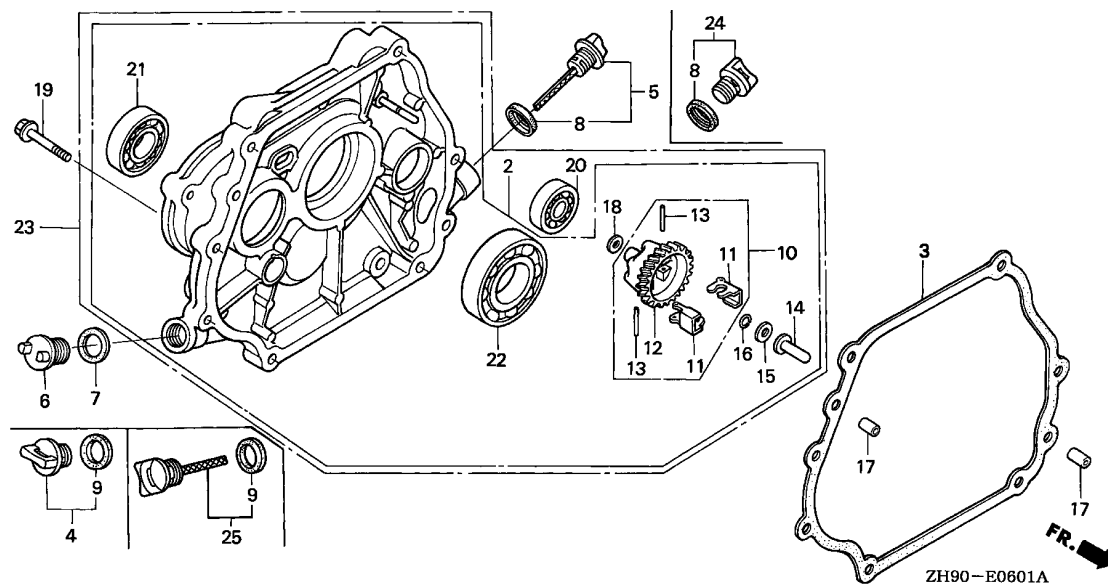

ZH90-E0601A



Ref. No.	Part No.	Description	Reqd. QTY			Serial No.	Parts catalogue code
			(1)	(2)	(3)		
11	16511-ZE2-000	WEIGHT, GOVERNOR	2	2	-	-----	LH,LH/A,LHB1,LHB3,LHB5,LHE,LHE/A,LHQ4,LJ,LJ/A,LJC,LJC/A,LJG,LJG/A,LSS,LT,LT/A,LTJ,LW,LW/A,LWD,LWD1,LWD1/A,LX,LX/A,LXE,LXE/A,LXE8,LXE8/A,LXQ4,LXQ4/A,LXU,LXU/A,LXZ,LX16,L1,L1/A
12	16512-ZE2-000	HOLDER, GOVERNOR WEIGHT	1	1	-	-----	LH,LH/A,LHB1,LHB3,LHB5,LHE,LHE/A,LHQ4,LJ,LJ/A,LJC,LJC/A,LJG,LJG/A,LT,LT/A,LW,LW/A,LWD,LX,LX/A,LXE,LXE/A,LXE8,LXE8/A,LXQ4,LXQ4/A,LXU,LXU/A,LXZ,LX16,L1,L1/A
	16512-ZE2-811	1	-	-	-----	LSS,LTJ,LWD1,LWD1/A
13	16513-ZE2-000	PIN, GOVERNOR WEIGHT	2	2	-	-----	LH,LH/A,LHB1,LHB3,LHB5,LHE,LHE/A,LHQ4,LJ,LJ/A,LJC,LJC/A,LJG,LJG/A,LSS,LT,LT/A,LTJ,LW,LW/A,LWD,LWD1,LWD1/A,LX,LX/A,LXE,LXE/A,LXE8,LXE8/A,LXQ4,LXQ4/A,LXU,LXU/A,LXZ,LX16,L1,L1/A
14	16531-ZE2-000	SLIDER, GOVERNOR	1	1	-	1832354	LH,LHE,LJ,LJC,LJG,LT,LW,LWD1,LX,LXE,LXE8,LXQ4,LXU,L1
	16531-Z0A-000	1	1	-	-----	LH/A,LHB1,LHB3,LHB5,LHE/A,LHQ4,LJ/A,LJC/A,LJG/A,LSS,LT/A,LTJ,LW/A,LWD,LWD1/A,LX/A,LXE/A,LXE8/A,LXQ4/A,LXU/A,LXZ,LX16,L1/A
15	90473-147-000	WASHER, 6X16	1	1	-	1832355	LH,LHE,LJ,LJC,LJG,LT,LW,LWD1,LX,LXE,LXE8,LXQ4,LXU,L1
			1	1	-	1065525	LJ,LWD,L1
			1	-	-	1064745	LH,LHE,LW,LX,LXZ
			1	1	-	1832355	LH,LHE,LJ,LJC,LJG,LT,LW,LWD1,LX,LXE,LXE8,LXQ4,LXU,L1
16	90602-ZE1-000	CLIP, GOVERNOR HOLDER	1	1	-	-----	LH,LH/A,LHB1,LHB3,LHB5,LHE,LHE/A,LHQ4,LJ,LJ/A,LJC,LJC/A,LJG,LJG/A,LSS,LT,LT/A,LTJ,LW,LW/A,LWD,LWD1,LWD1/A,LX,LX/A,LXE,LXE/A,LXE8,LXE8/A,LXQ4,LXQ4/A,LXU,LXU/A,LXZ,LX16,L1,L1/A
17	90701-HC4-000	DOWEL PIN, 8X12	2	2	-	-----	LH,LH/A,LHB1,LHB3,LHB5,LHE,LHE/A,LHQ4,LJ,LJ/A,LJC,LJC/A,LJG,LJG/A,LSS,LT,LT/A,LTJ,LW,LW/A,LWD,LWD1,LWD1/A,LX,LX/A,LXE,LXE/A,LXE8,LXE8/A,LXQ4,LXQ4/A,LXU,LXU/A,LXZ,LX16,L1,L1/A
18	94101-06800	WASHER, PLAIN, 6MM	1	1	-	-----	LH,LH/A,LHB1,LHB3,LHB5,LHE,LHE/A,LHQ4,LJ,LJ/A,LJC,LJC/A,LJG,LJG/A,LSS,LT,LT/A,LTJ,LW,LW/A,LWD,LWD1,LWD1/A,LX,LX/A,LXE,LXE/A,LXE8,LXE8/A,LXQ4,LXQ4/A,LXU,LXU/A,LXZ,LX16,L1,L1/A

E-6-1

CRANKCASE COVER(2)

G 2

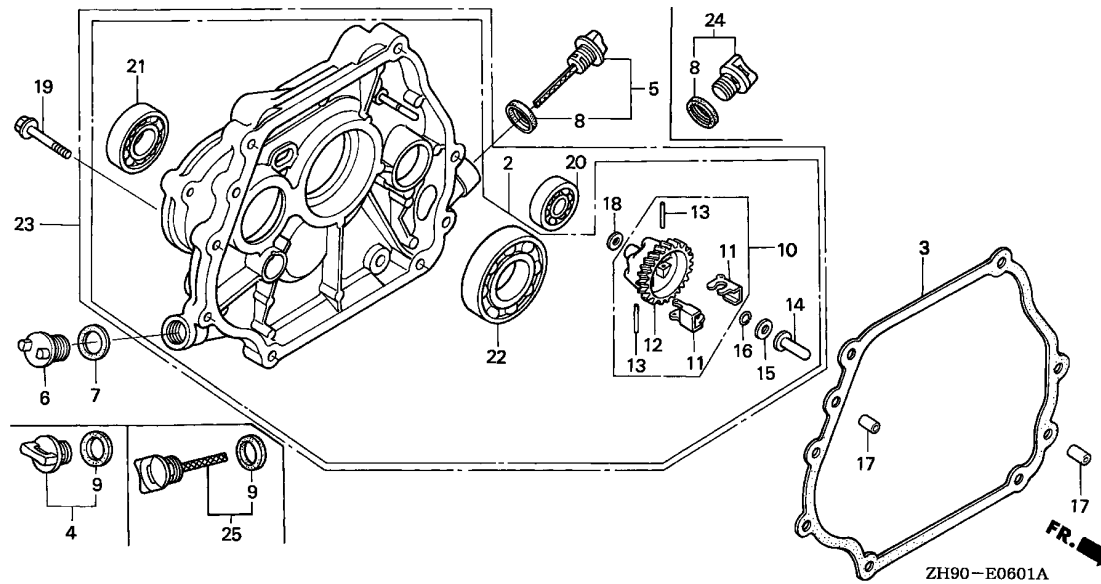

2

Ref. No.	Part No.	Description	Reqd. QTY			Serial No.	Parts catalogue code
			(1)	(2)	(3)		
19	95701-08035-00	BOLT, FLANGE, 8X35	7	7	-		LH/A,LHB1,LHB3,LHB5,LHE/A,LHQ4,LJ/A,LJC,LJC/A,LJG,LJG/A,LSS,LT LT/A,LTJ,LW/A,LWD,LWD1,LWD1/A,LX/A,LXE,LXE/A,LXE8,LXE8/A,LXQ4 LXQ4/A,LXU/A,LX16,L1/A
	95900-08035-00		7	7	-		LH,LHE,LJ,LW,LX,LXU,LXZ,L1
20	96100-62020-00	BEARING, RADIAL BALL, 6202	1	-	-		LSS,LTJ,LWD1,LWD1/A
21	96100-62040-00	BEARING, RADIAL BALL, 6204	1	1	-		LH,LH/A,LHB1,LHB3,LHB5,LHE,LHE/A,LHQ4,LJ,LJ/A,LJC,LJC/A,LJG,LJG/A LSS,LT,LT/A,LTJ,LW,LW/A,LWD,LWD1,LWD1/A,LX,LX/A,LXE,LXE/A,LXE8 LXE8/A,LXQ4,LXQ4/A,LXU,LXU/A,LXZ,LX16,L1,L1/A
22	96100-62060-00	BEARING, RADIAL BALL, 6206	1	1	-		LH,LH/A,LHB1,LHB3,LHB5,LHE,LHE/A,LHQ4,LJ,LJ/A,LJC,LJC/A,LJG,LJG/A LSS,LT,LT/A,LTJ,LW,LW/A,LWD,LWD1,LWD1/A,LX,LX/A,LXE,LXE/A,LXE8 LXE8/A,LXQ4,LXQ4/A,LXU,LXU/A,LXZ,LX16,L1,L1/A
23	11400-ZE2-611	COVER ASSY., CRANKCASE	1	-	-		LSS,LTJ
	11400-ZE2-612		1	-	-	1832354	LWD1
	11400-ZE2-613		1	-	-	1832355	LWD1
	11400-ZE2-613		1	-	-		LWD1/A
24	15600-ZG4-003	CAP ASSY., OIL FILLER	1	-	-		LWD1,LWD1/A
25	15600-735-003	CAP ASSY., OIL FILLER	1	-	-		LWD1,LWD1/A

E-6-2

CRANKCASE COVER(3)

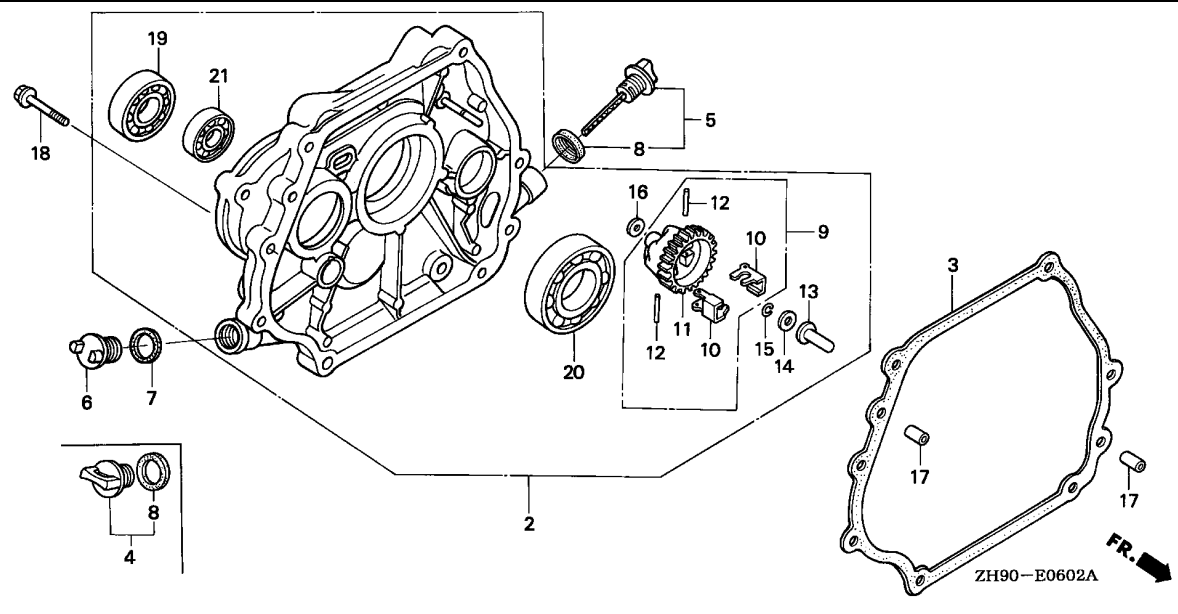
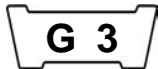

Ref. No.	L.O.N.	(Relative ref. Number) Description	F.R.T.
2	1101G0	COVER, CRANKCASE(A)	0.3
3	1101F9	PACKING, CRANKCASE COVER(A) .. (10)	0.3
11	1161C6	HOLDER, GOVERNOR WEIGHT(A) ...	0.4
13	1161B6	SLIDER, GOVERNOR	0.3
19	2141A7	BEARING, POWER TAKE OFF SHAFT :FRONT	0.4
20	1101A6	BEARING, CRANKSHAFT :REAR	0.4
21	2101U3	BEARING, COUNTERSHAFT :FRONT ..	0.4

Ref. No.	Part No.	Description	Reqd. QTY			Serial No.	Parts catalogue code
			(1)	(2)	(3)		
2	11300-ZE2-620	COVER ASSY., CRANKCASE	1	-	-	HH	
	11300-ZE2-621	1	-	-	1832354	HX, HXQ4, HX26, HX8
	11300-ZE2-622	1	-	-	1832355	HX, HXQ4, HX26, HX8
3	11381-ZE2-801	PACKING, CASE COVER	1	-	-		HX/A, HXQ4/A, HX26/A, HX8/A
4	15600-ZG4-003	CAP ASSY., OIL FILLER	1	-	-		HH, HX, HX/A, HXQ4, HXQ4/A, HX26, HX26/A, HX8, HX8/A
5	15600-735-003	CAP ASSY., OIL FILLER	1	-	-	1071799	HX/A, HXQ4, HXQ4/A, HX26, HX26/A, HX8, HX8/A
6	15620-ZG4-910	CAP, OIL FILLER	1	-	-		HH, HX
7	15621-896-010	PACKING, OIL FILLER CAP	1	-	-	1071798	HH, HX
8	15625-ZE1-003	PACKING, OIL FILLER CAP	1	-	-	1071798	HH, HX
			2	-	-		HX/A, HXQ4, HXQ4/A, HX26, HX26/A, HX8, HX8/A
			2	-	-	1071799	HH, HX
9	16510-ZE2-000	GOVERNOR ASSY.	1	-	-		HH, HX, HX/A, HXQ4, HXQ4/A, HX26, HX26/A, HX8, HX8/A
10	16511-ZE2-000	WEIGHT, GOVERNOR	2	-	-		HH, HX, HX/A, HXQ4, HXQ4/A, HX26, HX26/A, HX8, HX8/A
11	16512-ZE2-000	HOLDER, GOVERNOR WEIGHT	1	-	-		HH, HX, HX/A, HXQ4, HXQ4/A, HX26, HX26/A, HX8, HX8/A
12	16513-ZE2-000	PIN, GOVERNOR WEIGHT	2	-	-		HH, HX, HX/A, HXQ4, HXQ4/A, HX26, HX26/A, HX8, HX8/A
13	16531-ZE2-000	SLIDER, GOVERNOR	1	-	-	1832354	HX, HXQ4, HX26, HX8
	16531-Z0A-000	1	-	-		HH, HX/A, HXQ4/A, HX26/A, HX8/A
			1	-	-	1832355	HX, HXQ4, HX26, HX8
14	90473-147-000	WASHER, 6X16	1	-	-	1064745	HH
			1	-	-	1832355	HX, HXQ4, HX26, HX8
15	90602-ZE1-000	CLIP, GOVERNOR HOLDER	1	-	-		HX/A, HXQ4, HXQ4/A, HX26, HX26/A, HX8/A
	90602-896-000	1	-	-		HH, HX, HX8
16	94101-06800	WASHER, PLAIN, 6MM	1	-	-		HH, HX, HX/A, HXQ4, HXQ4/A, HX26, HX26/A, HX8, HX8/A
17	94301-08140	DOWEL PIN, 8X14	2	-	-		HH, HX, HX/A, HXQ4, HXQ4/A, HX26, HX26/A, HX8, HX8/A

E-6-2

CRANKCASE COVER(3)

G 4

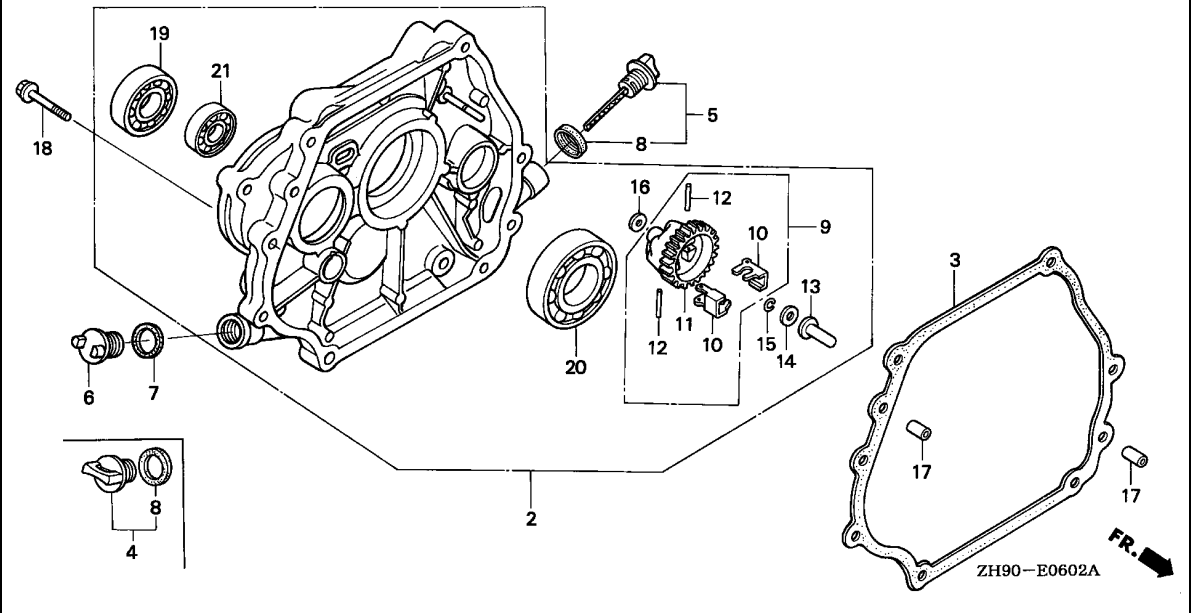

Ref. No.	Part No.	Description	Reqd. QTY			Serial No.	Parts catalogue code
			(1)	(2)	(3)		
18	95701-08035-00	BOLT, FLANGE, 8X35	7	-	-	-----	HX/A,HXQ4,HXQ4/A,HX26,HX26/A,HX8/A
	95900-08035-00	7	-	-	-----	HH,HX,HX8
19	96100-62040-00	BEARING, RADIAL BALL, 6204 ..	1	-	-	-----	HH,HX,HX/A,HXQ4,HXQ4/A,HX26,HX26/A,HX8,HX8/A
20	96100-62060-00	BEARING, RADIAL BALL, 6206 ..	1	-	-	-----	HH,HX,HX/A,HXQ4,HXQ4/A,HX26,HX26/A,HX8,HX8/A
21	96100-63020-00	BEARING, RADIAL BALL, 6302 ..	1	-	-	-----	HH,HX,HX/A,HXQ4,HXQ4/A,HX26,HX26/A,HX8,HX8/A

2

E-6-3

CRANKCASE COVER(4)

G 5

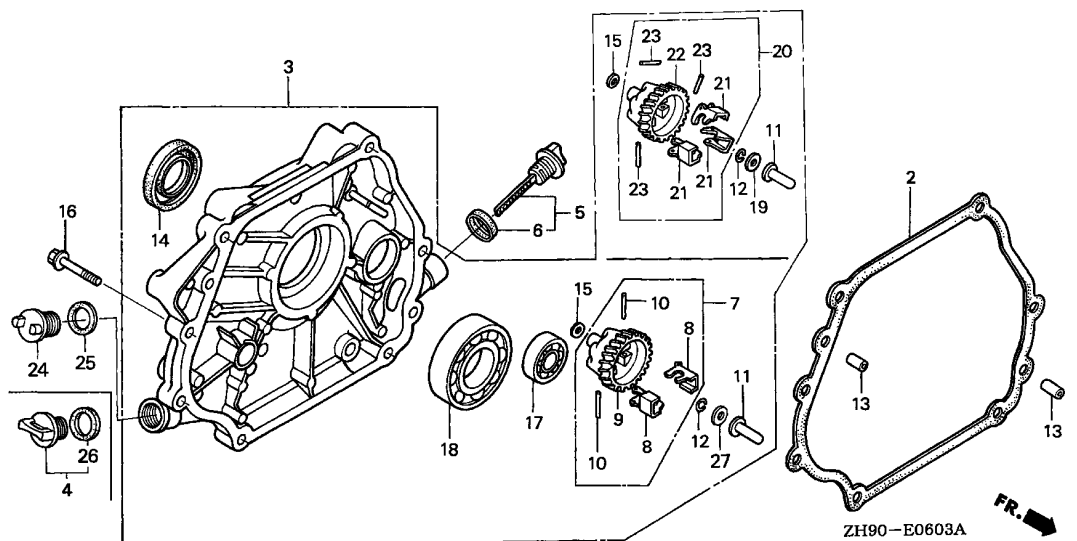

Ref. No.	L.O.N.	(Relative ref. Number) Description	F.R.T.
2	1101F9	PACKING, CRANKCASE COVER(A) ..	0.3
3	1101G0	COVER, CRANKCASE(A)	0.3
9		(8,21,22)	
	1161C6	HOLDER, GOVERNOR WEIGHT(A) ...	0.4
11	1161B6	SLIDER, GOVERNOR	0.3
14	1101E5	OIL SEAL, CRANKSHAFT :REAR ...	0.3
17	1101F5	BEARING, BALANCER WEIGHT :REAR	0.4
18	1101A6	BEARING, CRANKSHAFT :REAR	0.4

Ref. No.	Part No.	Description	Reqd. QTY			Serial No.	Parts catalogue code
			(1)	(2)	(3)		
2	11381-ZE2-801	PACKING, CASE COVER	1	(1)	-	PA,PAE2,PAE2/A,PA2,PA2/A,QA,QAB1,QAB3,QAB3/A,QAE,QAE2,QAE2/A,QAE6,QAE6/A,QAG,QAG/A,QAQ,QAQ4,QAQ4/A,QAR2,QAR2/A,QAW,QAW/A,QA2,QA2/A,QL2,QSC,QSC9,QSC9/A,QXB6,QXB6/A,QX26,QX26/A,Q2,RA,RA2,RA2/A,RSC2,RSC2/A,RSS,RSS/A,SK,VA,VAW,VAW1,VA2,VA2/A,VDE,VDE2,VDE2/A,VKB2,VKB2/A,VME2,VME2/A,VMS2,VMX2,VM2,VM2/A,VNT2,VNT2/A,VWA,VWA2,VWA2/A,VWN2,VWN2/A,VW12,VW12/A,VW22	
3	11400-ZE2-010	COVER ASSY., CRANKCASE	1	-	-	RA,SK	
	11400-ZE2-601	1	1	-	1832354 RA2,RSC2,RSS	
		1	-	-	PA,QA,QAB1,QAE,QAQ,QL2,QSC,Q2,VA,VAW,VAW1,VDE,VWA,VW22	
		1	-	-	1304886 VME2	
		1	-	-	1368686 VM2	
		1	-	-	1832354 PAE2,PA2,QAB3,QAE2,QAE6,QAG,QAQ4,QAR2,QAW,QA2,QSC9,QXB6,QX26,VA2,VDE2,VNT2,VWA2,VWN2,VW12	
	11400-ZE2-670	1	-	-	1832354 VKB2	
		1	-	-	1304887 1832354 VME2	
		1	-	-	1368687 1832354 VM2	
	11400-ZE2-020	1	-	-	1832355 RA2,RSC2,RSS	
	11400-ZE2-602	1	-	-	1832355 PAE2,PA2,QAB3,QAE2,QAE6,QAG,QAQ4,QAR2,QAW,QA2,QSC9,QXB6,QX26,VA2,VDE2,VNT2,VWA2,VWN2,VW12	
	11400-ZE2-671	1	-	-	VKB2/A,VME2/A,VMS2,VMX2,VM2/A	
		1	-	-	1832355 VKB2,VME2,VM2	
	11400-ZE2-030	1	-	-	RA2/A,RSC2/A,RSS/A	
	11400-ZE2-603	1	-	-	PAE2/A,PA2/A,QAB3/A,QAE2/A,QAE6/A,QAG/A,QAQ4/A,QAR2/A,QAW/A,QA2/A,QSC9/A,QXB6/A,QX26/A,VA2/A,VDE2/A,VNT2/A,VWA2/A,VWN2/A,VW12/A	

E-6-3

CRANKCASE COVER(4)



Ref. No.	Part No.	Description	Reqd. QTY			Serial No.	Parts catalogue code
			(1)	GX270 (2)	(3)		
4	15600-ZG4-003	CAP ASSY., OIL FILLER	1	1	-	1071799	PA,PA2,QA,QAE,QAE2,QAQ,QA2,QSC,Q2,RA,RA2,SK,VA,VAW,VA2,VWA,PAE2,PAE2/A,PA2/A,QAB1,QAB3,QAB3/A,QAE2/A,QAE6,QAE6/A,QAG,QAG/A,QAQ4,QAQ4/A,QAR2,QAR2/A,QAW,QAW/A,QA2/A,QL2,QSC9,QSC9/A,QXB6,QXB6/A,QX26,QX26/A,RA2/A,RSC2,RSC2/A,RSS,RSS/A,VAW1,VA2/A,VDE,VDE2,VDE2/A,VKB2,VKB2/A,VME2,VME2/A,VMS2,VMX2,VM2,VM2/A,VNT2,VNT2/A,VWA2,VWA2/A,VWN2,VWN2/A,VW12,VW12/A,VW22
5	15600-735-003	CAP ASSY., OIL FILLER	1	(1)	-		PA,PAE2,PAE2/A,PA2,PA2/A,QA,QAB1,QAB3,QAB3/A,QAE,QAE2,QAE2/A,QAE6,QAE6/A,QAG,QAG/A,QAQ,QAQ4,QAQ4/A,QAR2,QAR2/A,QAW,QAW/A,QA2,QA2/A,QL2,QSC,QSC9,QSC9/A,QXB6,QXB6/A,QX26,QX26/A,Q2,RA,RA2,RA2/A,RSC2,RSC2/A,RSS,RSS/A,SK,VA,VAW,VAW1,VA2,VA2/A,VDE,VDE2,VDE2/A,VKB2,VKB2/A,VME2,VME2/A,VMS2,VMX2,VM2,VM2/A,VNT2,VNT2/A,VWA,VWA2,VWA2/A,VWN2,VWN2/A,VW12,VW12/A,VW22
6	15625-ZE1-003	PACKING, OIL FILLER CAP	1	(1)	-		PA,PAE2,PAE2/A,PA2,PA2/A,QA,QAB1,QAB3,QAB3/A,QAE,QAE2,QAE2/A,QAE6,QAE6/A,QAG,QAG/A,QAQ,QAQ4,QAQ4/A,QAR2,QAR2/A,QAW,QAW/A,QA2,QA2/A,QL2,QSC,QSC9,QSC9/A,QXB6,QXB6/A,QX26,QX26/A,Q2,RA,RA2,RA2/A,RSC2,RSC2/A,RSS,RSS/A,SK,VA,VAW,VAW1,VA2,VA2/A,VDE,VDE2,VDE2/A,VKB2,VKB2/A,VME2,VME2/A,VMS2,VMX2,VM2,VM2/A,VNT2,VNT2/A,VWA,VWA2,VWA2/A,VWN2,VWN2/A,VW12,VW12/A,VW22
7	16510-ZE2-811	GOVERNOR ASSY.	1	1	-		PA,PAE2,PAE2/A,PA2,PA2/A,QA,QAB1,QAB3,QAB3/A,QAE,QAE2,QAE2/A,QAE6,QAE6/A,QAG,QAG/A,QAQ,QAQ4,QAQ4/A,QAR2,QAR2/A,QAW,QAW/A,QA2,QA2/A,QL2,QSC,QSC9,QSC9/A,QXB6,QXB6/A,QX26,QX26/A,Q2,RA,RA2,RA2/A,RSC2,RSC2/A,RSS,RSS/A,SK,VA,VAW,VAW1,VA2,VA2/A,VDE,VDE2,VDE2/A,VNT2,VNT2/A,VWA,VWA2,VWA2/A,VWN2,VWN2/A,VW12,VW12/A,VW22
8	16511-ZE2-000	WEIGHT, GOVERNOR	1	-	-	1304886	VME2
			1	-	-	1368686	VM2
9	16512-ZE2-811	HOLDER, GOVERNOR WEIGHT	2	-	-	1304886	VME2
			2	-	-	1368686	VM2
10	16513-ZE2-000	PIN, GOVERNOR WEIGHT	1	-	-	1304886	VME2
			1	-	-	1368686	VM2
11	16531-ZE2-000 16531-Z0A-000	SLIDER, GOVERNOR	1	-	-	1832354	PAE2,PA2,QAB3,QAE2,QAE6,QAG,QAQ4,QAR2,QAW,QA2,QSC9,QXB6,QX26,RA2,RSC2,RSS,VA2,VDE2,VKB2,VME2,VM2,VNT2,VWA2,VWN2,VW12
			1	1	-		PA,PAE2/A,PA2/A,QA,QAB1,QAB3/A,QAE,QAE2/A,QAE6/A,QAG/A,QAQ,QAQ4/A,QAR2/A,QA2/A,QL2,QSC,QSC9,QSC9/A,QXB6,QXB6/A,QX26,QX26/A,Q2,RA,RA2,RA2/A,RSC2/RSC2/A,RSS,RSS/A,SK,VA,VAW,VAW1,VA2,VA2/A,VDE,VDE2,VDE2/A,VNT2/VNT2/A,VWA,VWA2,VWA2/A,VWN2,VWN2/A,VW12,VW12/A,VW22
			1	-	-	1832355	PAE2,PA2,QAB3,QAE2,QAE6,QAG,QAQ4,QAR2,QAW,QA2,QSC9,QXB6,QX26,RA2,RSC2,RSS,VA2,VDE2,VKB2,VME2,VM2,VNT2,VWA2,VWN2,VW12



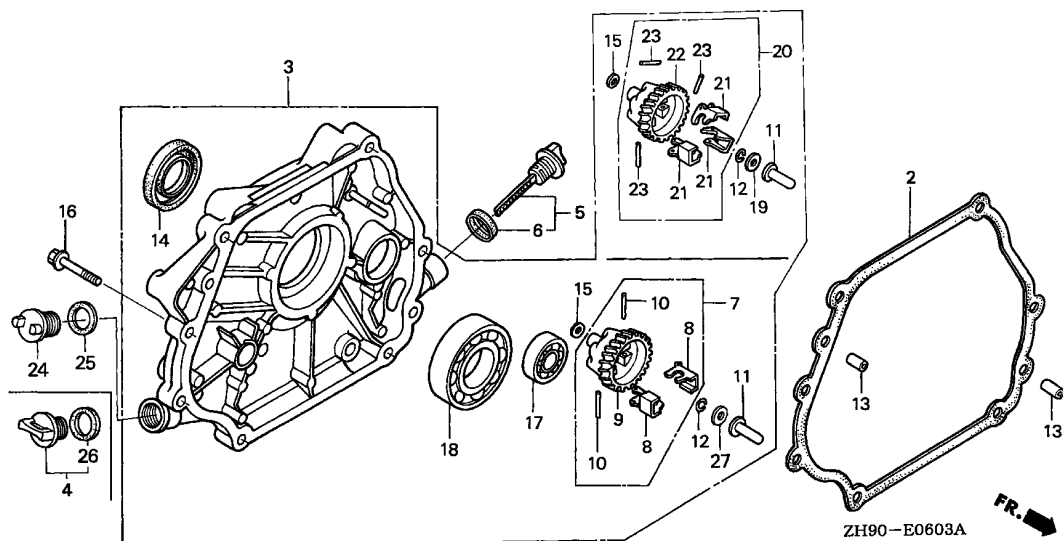

Ref. No.	Part No.	Description	Reqd. QTY			Serial No.	Parts catalogue code
			(1)	(2)	(3)		
12	90602-ZE1-000	CLIP, GOVERNOR HOLDER	1	1	-		PA,PAE2,PAE2/A,PA2,PA2/A,QA,QAB1,QAB3,QAB3/A,QAE,QAE2,QAE2/A,QAE6 QAE6/A,QAG,QAG/A,QAQ,QAQ4,QAQ4/A,QAR2,QAR2/A,QAW,QAW/A,QA2,QA2/A QL2,QSC,QSC9,QSC9/A,QXB6,QXB6/A,QX26,QX26/A,Q2,RA,RA2,RA2/A,RSC2 RSC2/A,RSS,RSS/A,SK,VA,VAW,VAW1,VA2,VA2/A,VDE,VDE2,VDE2/A,VKB2 VKB2/A,VME2,VME2/A,VMS2,VMX2,VM2,VM2/A,VNT2,VNT2/A,VWA,VWA2 VWA2/A,VWN2,VWN2/A,VW12,VW12/A,VW22
	90602-896-000		(1)	-	-		PA,PAE2,PAE2/A,PA2,PA2/A,QA,QAB1,QAB3,QAB3/A,QAE,QAE2,QAE2/A,QAE6 QAE6/A,QAG,QAG/A,QAQ,QAQ4,QAQ4/A,QAR2,QAR2/A,QAW,QAW/A,QA2,QA2/A,QX26 QX26/A,RA,RA2,RA2/A,RSC2,RSC2/A,RSS,RSS/A,SK,VA,VAW,VAW1,VA2 VA2/A,VDE,VDE2,VDE2/A,VKB2,VKB2/A,VME2/A,VM2/A,VNT2,VNT2/A,VWA VWA2,VWA2/A,VWN2,VWN2/A,VW12,VW12/A,VW22
			(1)	-	-	1304886	VME2
			(1)	-	-	1368686	VM2
13	90701-HC4-000	DOWEL PIN, 8X12	2	2	-		PA,PAE2,PAE2/A,PA2,PA2/A,QA,QAB1,QAB3,QAB3/A,QAE,QAE2,QAE2/A,QAE6 QAE6/A,QAG,QAG/A,QAQ,QAQ4,QAQ4/A,QAR2,QAR2/A,QAW,QAW/A,QA2,QA2/A QL2,QSC,QSC9,QSC9/A,QXB6,QXB6/A,QX26,QX26/A,Q2,RA,RA2,RA2/A,RSC2 RSC2/A,RSS,RSS/A,SK,VA,VAW,VAW1,VA2,VA2/A,VDE,VDE2,VDE2/A,VKB2 VKB2/A,VME2,VME2/A,VMS2,VMX2,VM2,VM2/A,VNT2,VNT2/A,VWA,VWA2 VWA2/A,VWN2,VWN2/A,VW12,VW12/A,VW22
14	91201-890-003	OIL SEAL, 30X46X8	1	1	-		PA,PAE2,PAE2/A,PA2,PA2/A,QA,QAB1,QAB3,QAB3/A,QAE,QAE2,QAE2/A,QAE6 QAE6/A,QAG,QAG/A,QAQ,QAQ4,QAQ4/A,QAR2,QAR2/A,QAW,QAW/A,QA2,QA2/A QL2,QSC,QSC9,QSC9/A,QXB6,QXB6/A,QX26,QX26/A,Q2,RA,RA2,RA2/A,RSC2 RSC2/A,RSS,RSS/A,SK,VA,VAW,VAW1,VA2,VA2/A,VDE,VDE2,VDE2/A,VKB2 VKB2/A,VME2,VME2/A,VMS2,VMX2,VM2,VM2/A,VNT2,VNT2/A,VWA,VWA2 VWA2/A,VWN2,VWN2/A,VW12,VW12/A,VW22

Ref. No.	Part No.	Description	Reqd. QTY			Serial No.	Parts catalogue code
			(1)	(2)	(3)		
15	94101-06800	WASHER, PLAIN, 6MM	1	1	-	-----	PA,PAE2,PAE2/A,PA2,PA2/A,QA,QAB1,QAB3,QAB3/A,QAE,QAE2,QAE2/A,QAE6,QAE6/A,QAG,QAG/A,QAQ,QAQ4,QAQ4/A,QAR2,QAR2/A,QAW,QAW/A,QA2,QA2/A,QL2,QSC,QSC9,QSC9/A,QXB6,QXB6/A,QX26,QX26/A,Q2,RA,RA2,RA2/A,RSC2,RSC2/A,RSS,RSS/A,SK,VA,VAW,VAW1,VA2,VA2/A,VDE,VDE2,VDE2/A,VKB2,VKB2/A,VME2,VME2/A,VMS2,VMX2,VM2,VM2/A,VNT2,VNT2/A,VWA,VWA2,VWA2/A,VWN2,VWN2/A,VW12,VW12/A,VW22
16	95701-08035-00	BOLT, FLANGE, 8X35	7	7	-	-----	PAE2,PAE2/A,PA2,PA2/A,QAB1,QAB3,QAB3/A,QAE2,QAE2/A,QAE6,QAE6/A,QAG,QAG/A,QAQ,QAQ4,QAQ4/A,QAR2,QAR2/A,QAW,QAW/A,QA2,QA2/A,QL2,QSC,QSC9,QSC9/A,QXB6,QXB6/A,QX26,QX26/A,Q2,RA2,RA2/A,RSC2,RSC2/A,RSS,RSS/A,VAW1,VA2,VA2/A,VDE,VDE2,VDE2/A,VKB2,VKB2/A,VME2,VME2/A,VMS2,VMX2,VM2,VM2/A,VNT2,VNT2/A,VWA,VWA2,VWA2/A,VWN2,VWN2/A,VW12,VW12/A,VW22
	95900-08035-00	7	-	-	-----	PA,QA,QAE,RA,SK,VA,VAW
17	96100-62020-00	BEARING, RADIAL BALL, 6202 ..	1	1	-	-----	PA,PAE2,PAE2/A,PA2,PA2/A,QA,QAB1,QAB3,QAB3/A,QAE,QAE2,QAE2/A,QAE6,QAE6/A,QAG,QAG/A,QAQ,QAQ4,QAQ4/A,QAR2,QAR2/A,QAW,QAW/A,QA2,QA2/A,QL2,QSC,QSC9,QSC9/A,QXB6,QXB6/A,QX26,QX26/A,Q2,RA,RA2,RA2/A,RSC2,RSC2/A,RSS,RSS/A,SK,VA,VAW,VAW1,VA2,VA2/A,VDE,VDE2,VDE2/A,VKB2,VKB2/A,VME2,VME2/A,VMS2,VMX2,VM2,VM2/A,VNT2,VNT2/A,VWA,VWA2,VWA2/A,VWN2,VWN2/A,VW12,VW12/A,VW22
18	96100-62060-00	BEARING, RADIAL BALL, 6206 ..	1	1	-	-----	PA,PAE2,PAE2/A,PA2,PA2/A,QA,QAB1,QAB3,QAB3/A,QAE,QAE2,QAE2/A,QAE6,QAE6/A,QAG,QAG/A,QAQ,QAQ4,QAQ4/A,QAR2,QAR2/A,QAW,QAW/A,QA2,QA2/A,QL2,QSC,QSC9,QSC9/A,QXB6,QXB6/A,QX26,QX26/A,Q2,RA,RA2,RA2/A,RSC2,RSC2/A,RSS,RSS/A,SK,VA,VAW,VAW1,VA2,VA2/A,VDE,VDE2,VDE2/A,VKB2,VKB2/A,VME2,VME2/A,VMS2,VMX2,VM2,VM2/A,VNT2,VNT2/A,VWA,VWA2,VWA2/A,VWN2,VWN2/A,VW12,VW12/A,VW22
19	90473-147-000	WASHER, 6X16	1	-	-	-----	VKB2,VKB2/A,VME2/A,VMS2,VMX2,VM2/A
			1	-	-	1304887	VME2
			1	-	-	1368687	VM2
20	16510-ZE3-000	GOVERNOR ASSY.	1	-	-	-----	VKB2,VKB2/A,VME2/A,VMS2,VMX2,VM2/A
			1	-	-	1304887	VME2
			1	-	-	1368687	VM2
21	16511-ZE8-000	WEIGHT, GOVERNOR	3	-	-	-----	VKB2,VKB2/A,VME2/A,VMS2,VMX2,VM2/A
			3	-	-	1304887	VME2
			3	-	-	1368687	VM2
22	16512-ZE3-000	HOLDER, GOVERNOR WEIGHT	1	-	-	-----	VKB2,VKB2/A,VME2/A,VMS2,VMX2,VM2/A
			1	-	-	1304887	VME2
			1	-	-	1368687	VM2
23	16513-ZE2-000	PIN, GOVERNOR WEIGHT	3	-	-	-----	VKB2,VKB2/A,VME2/A,VMS2,VMX2,VM2/A
			3	-	-	1304887	VME2
			3	-	-	1368687	VM2
24	15620-ZG4-910	CAP, OIL FILLER	1	1	-	1071798	PA,PA2,QA,QAE,QAE2,QAQ,QA2,QSC,Q2,RA,RA2,SK,VA,VAW,VA2,VWA
25	15621-896-010	PACKING, OIL FILLER CAP	1	1	-	1071798	PA,PA2,QA,QAE,QAE2,QAQ,QA2,QSC,Q2,RA,RA2,SK,VA,VAW,VA2,VWA
26	15625-ZE1-003	PACKING, OIL FILLER CAP	1	1	-	1071799	PA,PA2,QA,QAE,QAE2,QAQ,QA2,QSC,Q2,RA,RA2,SK,VA,VAW,VA2,VWA
			1	-	-	-----	PAE2,PAE2/A,PA2/A,QAB1,QAB3,QAB3/A,QAE2/A,QAE6,QAE6/A,QAG,QAG/A,QAQ4,QAQ4/A,QAR2,QAR2/A,QAW,QAW/A,QA2/A,QL2,QSC9,QSC9/A,QXB6,QXB6/A,QX26,QX26/A,RA2/A,RSC2,RSC2/A,RSS,RSS/A,VAW1,VA2/A,VDE,VDE2,VDE2/A,VKB2,VKB2/A,VME2,VME2/A,VMS2,VMX2,VM2,VM2/A,VNT2,VNT2/A,VWA2,VWA2/A,VWN2,VWN2/A,VW12,VW12/A,VW22
27	90473-147-000	WASHER, 6X16	1	1	-	1064745	PA,QA,QAE,QSC,Q2,RA,VA,VAW,VWA
			1	-	-	1065525	SK
			1	-	-	1090816	PA2,QAE2,QAQ,QA2,RA2,VA2
			1	-	-	1832355	PAE2,PA2,QAB3,QAE2,QAE6,QAG,QAQ4,QAR2,QAW,QA2,QSC9,QXB6,QX26,RA2,RSC2,RSS,VA2,VDE2,VNT2,VWA2,VWN2,VW12



E-6-4

CRANKCASE COVER(5)

G 9

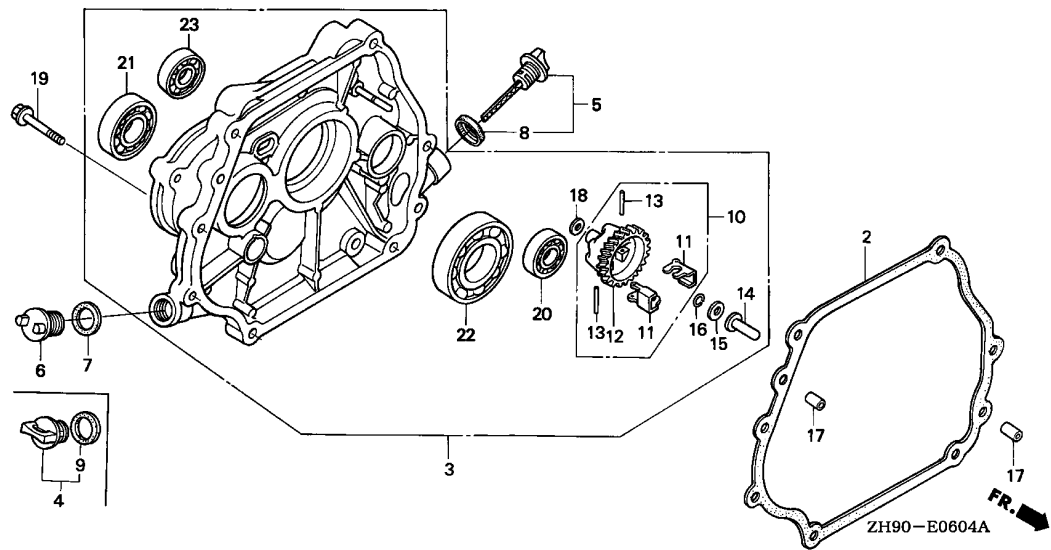

Ref. No.	L.O.N.	(Relative ref. Number) Description	F.R.T.
2	1101F9	PACKING, CRANKCASE COVER(A) ..	0.3
3	1101G0	COVER, CRANKCASE(A)	0.3
12		(11)	
	1161C6	HOLDER, GOVERNOR WEIGHT(A) ...	0.4
14	1161C7	SLIDER, GOVERNOR(A)	0.3
20	1101F5	BEARING, BALANCER WEIGHT :REAR	0.4
21	2141A7	BEARING, POWER TAKE OFF SHAFT	
		:FRONT	0.4
22	1101A6	BEARING, CRANKSHAFT :REAR	0.4
23	2101U3	BEARING, COUNTERSHAFT :FRONT ..	0.4

2

Ref. No.	Part No.	Description	Reqd. QTY			Serial No.	Parts catalogue code
			(1)	(2)	(3)		
2	11381-ZE2-801	PACKING, CASE COVER	1	-	1	-----	HA,HAP,HAP/A,HAQ,HA2,HA2/A,HEA,HEA2,HEA2/A,HEA8,HEA8/A
3	11400-ZE2-621	COVER ASSY., CRANKCASE	1	-	-	-----	HA,HAQ,HEA
	11400-ZE2-622	1	-	-	1832354	HA2,HEA2,HEA8
	11400-ZE2-623	1	-	-	1832355	HA2,HEA2,HEA8
4	15600-ZG4-003	CAP ASSY., OIL FILLER	1	-	1	-----	HAP
	15600-ZG4-003	1	-	1	-----	HAP/A,HA2/A,HEA2/A,HEA8/A
5	15600-735-700	CAP ASSY., OIL FILLER	1	-	-	1071799	HAP,HAP/A,HA2/A,HEA2,HEA2/A,HEA8,HEA8/A
	15600-735-003	1	-	-	1071798	HA2,HEA
	15600-735-003	1	-	-	1071798	HA,HEA
	15600-735-003	1	-	-	1071799	HAQ,HA2
	15600-735-003	1	-	-	1071799	HAP,HAP/A,HA2/A,HEA2,HEA2/A,HEA8,HEA8/A
	15600-735-003	1	-	-	1071799	HAQ,HA2
6	15620-ZG4-910	CAP, OIL FILLER	1	-	-	-----	HA,HAQ
	15620-ZG4-910	1	-	-	1071798	HA2,HEA
7	15621-896-010	PACKING, OIL FILLER CAP	1	-	-	-----	HA,HAQ
	15621-896-010	1	-	-	1071798	HA2,HEA
8	15625-ZE1-000	PACKING, OIL FILLER CAP	1	-	-	-----	HA,HEA
	15625-ZE1-000	1	-	-	1071798	HAQ,HA2
	15625-ZE1-003	1	-	1	-----	HAP,HAP/A,HA2/A,HEA2,HEA2/A,HEA8,HEA8/A
	15625-ZE1-003	1	-	-	1071799	HAQ,HA2
9	15625-ZE1-003	PACKING, OIL FILLER CAP	1	-	1	-----	HAP,HAP/A,HA2/A,HEA2,HEA2/A,HEA8,HEA8/A
	15625-ZE1-003	1	-	-	1071799	HA2,HEA
10	16510-ZE2-811	GOVERNOR ASSY.	1	-	1	-----	HA,HAP,HAP/A,HAQ,HA2,HA2/A,HEA,HEA2,HEA2/A,HEA8,HEA8/A
11	16511-ZE2-000	WEIGHT, GOVERNOR	2	-	2	-----	HA,HAP,HAP/A,HAQ,HA2,HA2/A,HEA,HEA2,HEA2/A,HEA8,HEA8/A
12	16512-ZE2-811	HOLDER, GOVERNOR WEIGHT	1	-	1	-----	HA,HAP,HAP/A,HAQ,HA2,HA2/A,HEA,HEA2,HEA2/A,HEA8,HEA8/A
13	16513-ZE2-000	PIN, GOVERNOR WEIGHT	2	-	2	-----	HA,HAP,HAP/A,HAQ,HA2,HA2/A,HEA,HEA2,HEA2/A,HEA8,HEA8/A
14	16531-ZE2-000	SLIDER, GOVERNOR	1	-	-	1832354	HA2,HEA2,HEA8

E-6-4

CRANKCASE COVER(5)

G10

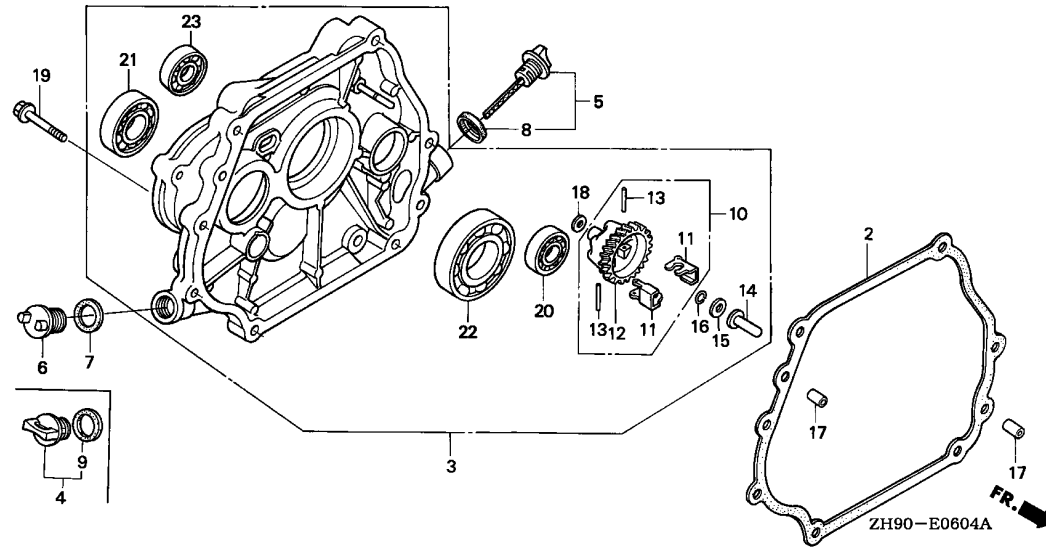

2

Ref. No.	Part No.	Description	Reqd. QTY			Serial No.	Parts catalogue code
			(1)	(2)	(3)		
14)	16531-Z0A-000	SLIDER, GOVERNOR	1	-	1	-----	HA,HAP,HAP/A,HAQ,HA2/A,HEA,HEA2/A,HEA8/A
15	90473-147-000	WASHER, 6X16	1	-	-	1832355	----- HA2,HEA2,HEA8
			1	-	-	1064745	----- HA,HEA
			1	-	-	1090816	----- HAQ
			1	-	-	1832355	----- HA2,HEA2,HEA8
			-	-	1	-----	HAP
16	90602-ZE1-000	CLIP, GOVERNOR HOLDER	1	-	1	-----	HA,HAP,HAP/A,HAQ,HA2,HA2/A,HEA,HEA2,HEA2/A,HEA8,HEA8/A
	90602-896-000	(1)	-	-	-----	HA,HEA,HEA2,HEA2/A,HEA8,HEA8/A
17	90701-HC4-000	DOWEL PIN, 8X12	2	-	2	-----	HA,HAP,HAP/A,HAQ,HA2,HA2/A,HEA,HEA2,HEA2/A,HEA8,HEA8/A
18	94101-06800	WASHER, PLAIN, 6MM	1	-	1	-----	HA,HAP,HAP/A,HAQ,HA2,HA2/A,HEA,HEA2,HEA2/A,HEA8,HEA8/A
19	95701-08035-00	BOLT, FLANGE, 8X35	7	-	7	-----	HAP,HAP/A,HAQ,HA2,HA2/A,HEA,HEA2,HEA2/A,HEA8,HEA8/A
	95900-08035-00	7	-	-	-----	HA
20	96100-62020-00	BEARING, RADIAL BALL, 6202 ..	1	-	1	-----	HA,HAP,HAP/A,HAQ,HA2,HA2/A,HEA,HEA2,HEA2/A,HEA8,HEA8/A
21	96100-62040-00	BEARING, RADIAL BALL, 6204 ..	1	-	1	-----	HA,HAP,HAP/A,HAQ,HA2,HA2/A,HEA,HEA2,HEA2/A,HEA8,HEA8/A
22	96100-62060-00	BEARING, RADIAL BALL, 6206 ..	1	-	1	-----	HA,HAP,HAP/A,HAQ,HA2,HA2/A,HEA,HEA2,HEA2/A,HEA8,HEA8/A
23	96100-63020-00	BEARING, RADIAL BALL, 6302 ..	1	-	1	-----	HA,HAP,HAP/A,HAQ,HA2,HA2/A,HEA,HEA2,HEA2/A,HEA8,HEA8/A

E-6-5

CRANKCASE COVER(6)

G11

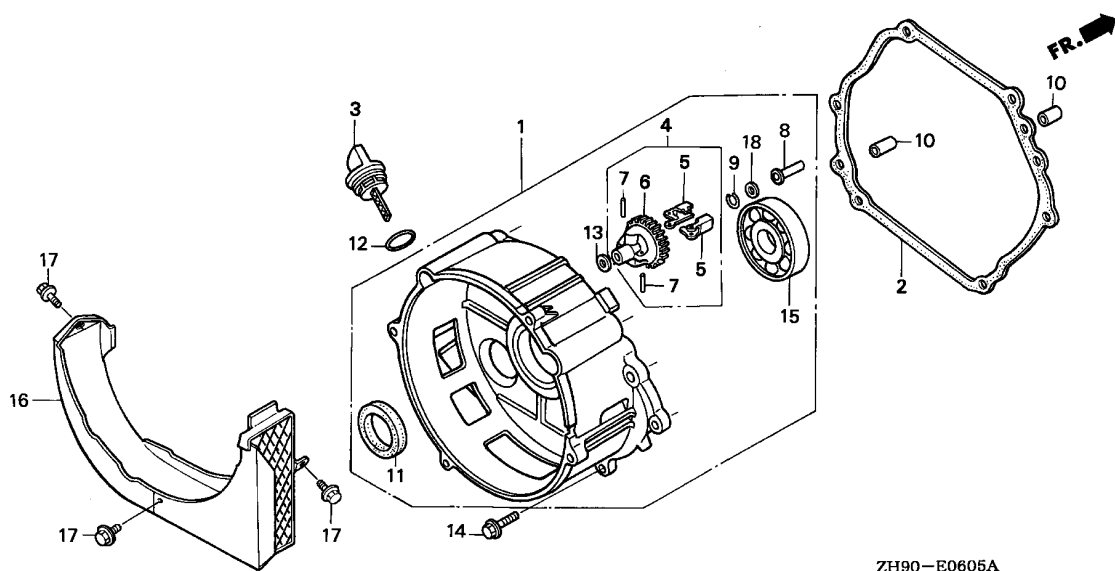

Ref. No.	L.O.N.	(Relative ref. Number) Description	F.R.T.
1	1101G0	COVER, CRANKCASE(A)	0.3
2	1101E9	PACKING, CRANKCASE COVER (5)	0.2
6	1161A7	HOLDER, GOVERNOR WEIGHT	0.3
8	1161B6	SLIDER, GOVERNOR	0.3
11	1101G3	OIL SEAL, CRANKCASE COVER	0.3
15	1101A6	BEARING, CRANKSHAFT :REAR	0.4
16	4141J5	COVER, DUCT	0.1

ZH90-E0605A

Ref. No.	Part No.	Description	Reqd. QTY			Serial No.	Parts catalogue code
			(1)	(2)	(3)		
1	11300-ZE2-700	COVER ASSY., CRANKCASE	1	-	-	1832354	ESS,ES3,VMT
	11300-ZE2-701	1	-	-	1832355	ESS,ES3,VMT
	11300-ZE2-406	1	-	-	-----	ESS/A,ES3/A,VMT/A
2	11381-ZE2-801	PACKING, CASE COVER	1	-	-	-----	ESS,ESS/A,ES3,ES3/A,VMT,VMT/A
3	15620-ZE2-700	CAP, OIL FILLER	1	-	-	-----	ESS,ESS/A,ES3,ES3/A,VMT,VMT/A
4	16510-ZE2-000	GOVERNOR ASSY.	1	-	-	-----	ESS,ESS/A,ES3,ES3/A,VMT,VMT/A
5	16511-ZE2-000	WEIGHT, GOVERNOR	2	-	-	-----	ESS,ESS/A,ES3,ES3/A,VMT,VMT/A
6	16512-ZE2-000	HOLDER, GOVERNOR WEIGHT	1	-	-	-----	ESS,ESS/A,ES3,ES3/A,VMT,VMT/A
7	16513-ZE2-000	PIN, GOVERNOR WEIGHT	2	-	-	-----	ESS,ESS/A,ES3,ES3/A,VMT,VMT/A
8	16531-ZE2-000	SLIDER, GOVERNOR	1	-	-	1832354	ESS,ES3,VMT
	16531-Z0A-000	1	-	-	-----	ESS/A,ES3/A,VMT/A
		1	-	-	1832355	ESS,ES3,VMT
9	90602-ZE1-000	CLIP, GOVERNOR HOLDER	1	-	-	-----	ESS,ESS/A,ES3,ES3/A,VMT,VMT/A
10	90701-HC4-000	DOWEL PIN, 8X12	2	-	-	-----	ESS,ESS/A,ES3,ES3/A,VMT,VMT/A
11	91201-890-003	OIL SEAL, 30X46X8	1	-	-	-----	ESS,ESS/A,ES3,ES3/A,VMT,VMT/A
12	91301-805-000	O-RING, 26X2.7	1	-	-	-----	ESS,ESS/A,ES3,ES3/A,VMT,VMT/A
13	94101-06800	WASHER, PLAIN, 6MM	1	-	-	-----	ESS,ESS/A,ES3,ES3/A,VMT,VMT/A
14	95701-08035-00	BOLT, FLANGE, 8X35	7	-	-	-----	ESS,ESS/A,ES3,ES3/A,VMT,VMT/A
15	96100-62060-00	BEARING, RADIAL BALL, 6206	1	-	-	-----	ESS,ESS/A,ES3,ES3/A,VMT,VMT/A
16	11315-ZE2-700	COVER, DUCT	1	-	-	-----	VMT,VMT/A
17	90019-883-000	BOLT, FLANGE, 5X10	3	-	-	-----	VMT,VMT/A
18	90473-147-000	WASHER, 6X16	1	-	-	1832355	ESS,ES3,VMT

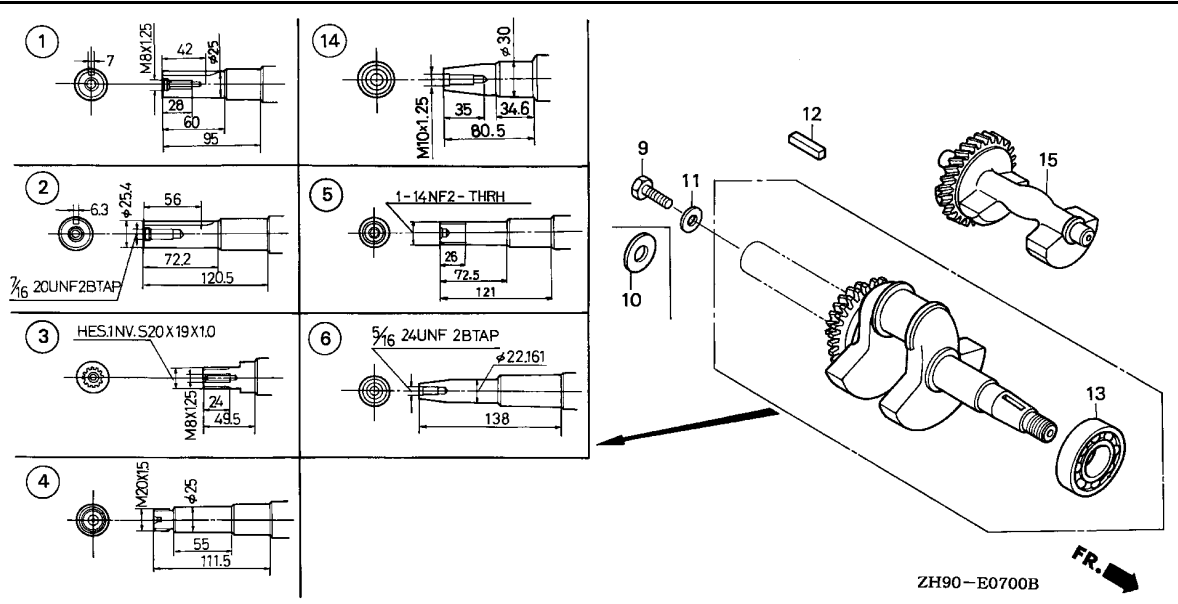

Ref. No.	L.O.N.	(Relative ref. Number) Description	F.R.T.
1		(2,3,4,5,6,14)	
1101F0		CRANKSHAFT	1.1
13		BEARING, CRANKSHAFT :FRONT ...	1.3
15		WEIGHT, BALANCER	0.3

Ref. No.	Part No.	Description	Reqd. QTY			Serial No.	Parts catalogue code	
			(1)	(2)	(3)			
1	13310-ZH9-000	CRANKSHAFT COMP.	1	1	1	RD, RH, RHE, RHE4, RHQ4, RH26, RX, RXP, RXQ4, RXU, R1, SD, SE, SH, SHE, SHEZ, SHQ4, SJ, SJG, SJP, SKE1, SMC4, SMD, SME1, SME6, SN, SW, SWC4, SWE, SX, SXB, SXE, SXEB, SXE4, SXE8, SXQ4, SXU, SX2, S1		
			1	1	-	2394272	RD/A, RHE4/A, RHQ4/A, RH26/A, RX/A, RXQ4/A, RXU/A, R1/A, SD/A, SE/A, SH/A, SHQ4/A, SJ/A, SJG/A, SMC4/A, SME1/A, SME6/A, SMX2, SN/A, SWA4, SWC4/A, SX/A, SXB/A, SXE/A, SXEB/A, SXE4/A, SXE8/A, SXQ4/A, SXU/A, S1/A	
	13310-ZH9-800	1	-	-	2395512	RXP/A	
	13310-ZK9-000	1	-	-	2394435	RA, RA2, RSC2, RSS, SK	
	13310-ZH9-010	1	-	-		RA2/A, RSC2/A, RSS/A	
			1	-	-		SXB7, SXB7/A	
			1	1	-	2394273	RD/A, RHE4/A, RHQ4/A, RH26/A, RX/A, RXQ4/A, RXU/A, R1/A, SD/A, SE/A, SH/A, SHQ4/A, SJ/A, SJG/A, SMC4/A, SME1/A, SME6/A, SMX2, SN/A, SWA4, SWC4/A, SX/A, SXB/A, SXE/A, SXEB/A, SXE4/A, SXE8/A, SXQ4/A, SXU/A, S1/A	
	13310-ZH9-801	-	-	1	2395513	RXP/A	
2	13310-ZH9-600	CRANKSHAFT COMP.	1	1	-	2394436	RA2/A, RSC2/A, RSS/A	
			1	1	-		QAG2, QD, QE, QH, QHC, QHE, QHE4, QHP1, QHQ4, QHR, QHR4, QHZ, QH26, QKE3, QME2, QMH, QP, QSE, QSE8, QT, QWA2, QWA4, QWH2, QX, QXB, QXC, QXC4, QXC6, QXC9, QXE, QXEB, QXE4, QXE6, QXE8, QXQ4, QXU, Q1	
			1	1	-	2395510	QAG2/A, QD/A, QE/A, QH/A, QHB5, QHE4/A, QHP1/A, QHQ4/A, QHR/A, QHR4/A, QHZ/A, QH26/A, QKE3/A, QKE4, QME2/A, QMH/A, QP/A, QSE/A, QSE2, QSE8/A, QT/A, QWA4/A, QWH2/A, QX/A, QXB/A, QXC4/A, QXC6/A, QXC9/A, QXE/A, QXE4/A, QXE6/A, QXE8/A, QXQ4/A, QXU/A, Q1/A	
	13310-ZH9-810	1	1	-		QA, QAB1, QAB3, QAE, QAE2, QAE6, QAG, QAQ, QAQ4, QAR2, QAW, QA2, QL2, QSC, QSC9, QXB6, QX26, Q2	
			1	-	-	2400731	QAB3/A, QAE2/A, QAE6/A, QAG/A, QAQ4/A, QAR2/A, QAW/A, QA2/A, QSC9/A	
	13310-ZK9-600	1	-	-		QXB6/A, QX26/A	
			1	-	-		QXB7, QXB7/A	



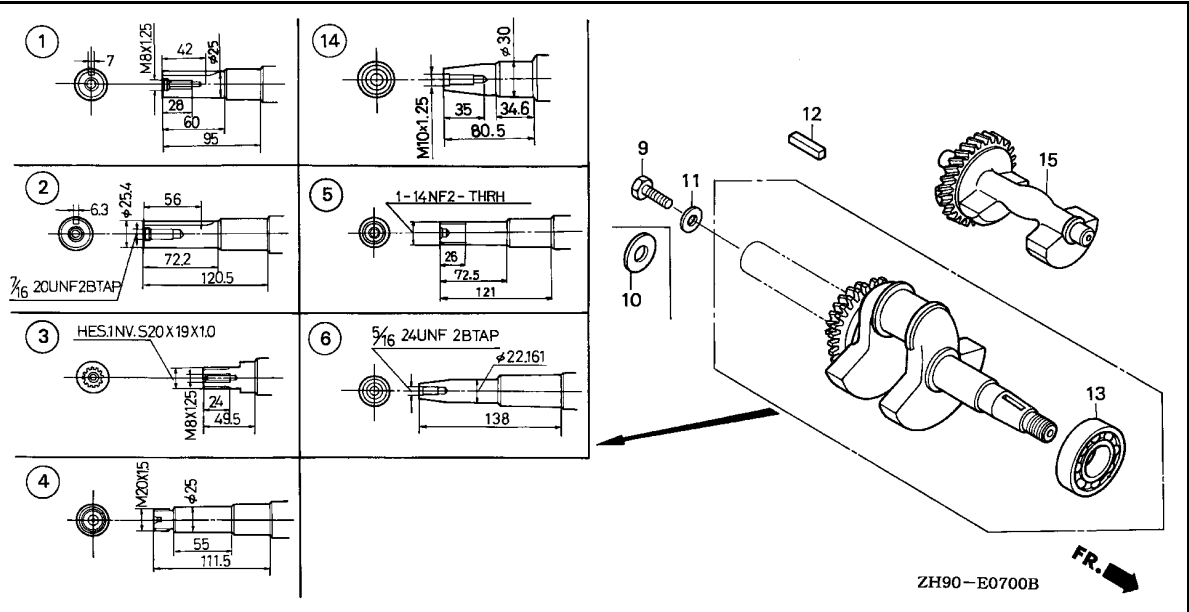

Ref. No.	Part No.	Description	Reqd. QTY			Serial No.	Parts catalogue code
			(1)	(2)	(3)		
(2)	13310-ZH9-601	CRANKSHAFT COMP.	1	1	-	2395511	----- QAG2/A,QD/A,QE/A,QH/A,QHB5,QHE4/A,QHP1/A,QHQ4/A,QHR/A,QHR4/A,QHZ/A,QH26/A,QKE3/A,QKE4,QME2/A,QMH/A,QP/A,QSE/A,QSE2,QSE8/A,QT/A,QWA4/A,QWH2/A,QX/A,QXB/A,QXC4/A,QXC6/A,QXC9/A,QXE/A,QXE4/A,QXE6/A,QXE8/A,QXQ4/A,QXU/A,Q1/A
	13310-ZH9-811	1	-	-	2400732	----- QAB3/A,QAE2/A,QAE6/A,QAG/A,QAQ4/A,QAR2/A,QAW/A,QA2/A,QSC9/A,QXB6/A,QX26/A
3	13310-ZH9-610	CRANKSHAFT COMP.	1	1	-	-----	----- HH,HX,HXQ4,HX26,HX8,LH,LHB1,LHB3,LHE,LHQ4,LJ,LJC,LJG,LT,LW,LWD,LX,LXE,LXE8,LXQ4,LXU,LXZ,LX16,L1
	13310-ZH9-820	1	-	1	2394580	----- HX/A,HXQ4/A,HX26/A,HX8/A,LH/A,LHB5,LHE/A,LJ/A,LJC/A,LJG/A,LT/A,LW/A,LX/A,LXE/A,LXE8/A,LXQ4/A,LXU/A,L1/A
	13310-ZH9-611	1	1	-	2394581	----- HA,HAP,HAP/A,HAQ,HA2,HA2/A,HEA,HEA2,HEA2/A,HEA8,HEA8/A,LSS,LTJ,LWD1,LWD1/A
4	13310-ZH9-630	CRANKSHAFT COMP.	1	1	-	-----	----- WMA4,WMT8,WMT8/A,WXE8,WXE8/A,W1,W1/A
5	13310-ZH9-650	CRANKSHAFT COMP.	1	-	-	-----	----- PX,PX/A,PXE8,PXE8/A,PXU,PXU/A,PX26,PX26/A
	13310-ZH9-830	1	-	-	-----	----- PA,PAE2,PAE2/A,PA2,PA2/A
6	13310-ZH9-670	CRANKSHAFT COMP.	1	1	1	-----	----- VAG2,VD16,VEB6,VH,VNG1,VP4,VPX4,VSD,VSD3,VWT4,VX,VXB,VXB2,VXB6,VXE,VXE8,VXE4,VXE6,VXG,VXP,VPX/A,VXQP,VXQ4,VXTB,VXT1,VXU,VXU1,VX26,V1
			1	-	-	2133729	----- VPE4/A,VPX4/A
			1	-	-	2394170	----- VAG2/A,VKE4,VKX4,VNG1/A,VSD/A,VSD3/A,VS3,VWT4/A,VX/A,VXB/A,VXE8/A,VXE4/A,VXE6/A,VXQ4/A,VXT1/A,VXU/A,VXU1/A
	13310-ZH9-840	1	-	-	-----	----- VA,VAW,VAW1,VA2,VA2/A,VDE,VDE2,VDE2/A,VKB2,VKB2/A,VME2,VME2/A,VMS2,VMX2,VM2,VM2/A,VNT2,VNT2/A,VPE5,VPX5,VWA,VWA2,VWA2/A,VWN2,VWN2/A,VW12,VW12/A,VW22
			1	-	-	2133730	----- VPE4/A,VPX4/A

Ref. No.	Part No.	Description	Reqd. QTY			Serial No.	Parts catalogue code
			(1)	(2)	(3)		
(6)	13310-ZK9-670	CRANKSHAFT COMP.	1	-	-	-----	VN17,VN17/A,VPE7,VPE7/A,VPX7,VPX7/A,VSD7,VSD7/A,VSH7,VS37,VS37/A VXB7,VXE7
	13310-ZK9-800	1	-	-	-----	2135204 VXB7/A,VXE7/A
	13310-ZH9-671	1	-	-	-----	2135205 VXB7/A,VXE7/A
						-----	2394171 VAG2/A,VKE4,VKX4,VNG1/A,VSD/A,VSD3/A,VS3,VMT4/A,VX/A,VXB/A,VXEB/A VXE4/A,VXE6/A,VXQ4/A,VXT1/A,VXU/A,VXU1/A
9	90003-ZE3-600	BOLT, HEX., 3/8-24UNF (25MM) .	1	-	-	-----	LT,LT/A
	90003-ZE2-000	BOLT, HEX. (7/16-20UNF)	-	(1)	-	-----	Q1,Q1/A
	92000-08025-0A	BOLT, HEX., 8X25	1	(1)	-	-----	R1,R1/A,SJP,SK,S1,S1/A
	92101-08025-0A	1	-	-	-----	SJ,SJ/A,SJG,SJG/A,SMX2
10	90473-ZE2-000	WASHER, 11.7MM	-	(1)	-	-----	Q1,Q1/A
11	90534-706-010	WASHER, LOCK, 8MM	1	(1)	-	-----	R1,R1/A,SJ,SJ/A,SJG,SJG/A,SJP,SK,SMX2,S1,S1/A
12	90741-805-000	KEY, 7X7X33	1	(1)	-	-----	SD,SD/A,SE,SE/A,SH,SH/A,SHE,SHEZ,SHQ4,SHQ4/A,SJ,SJ/A,SJG,SJG/A SJP,SK,SKE1,SMD,SMX2,SN,SN/A,SW,SWA4,SWC4,SWC4/A,SWE,SX,SX/A,SXB SXB/A,SXB7,SXB7/A,SXE,SXE/A,SXEB,SXEB/A,SXE4,SXE4/A,SXE8,SXE8/A SXQ4,SXQ4/A,SXU,SXU/A,S1,S1/A
	90741-889-810	KEY, 7X7X33 (YELLOW)	(1)	(1)	-	-----	ES1,ES1/A,ES3,ES3/A,L1,L1/A,SD,SD/A,SE,SE/A,SH,SH/A,SHQ4,SHQ4/A SJ,SJ/A,SJG,SJG/A,SJP,SK,SKE1,SMC4,SMC4/A,SMD,SME1,SME1/A,SME6 SME6/A,SN,SN/A,SWA4,SWC4,SWC4/A,SX,SX/A,SXB,SXB/A,SXB7,SXB7/A,SXE SXE/A,SXEB,SXEB/A,SXE4,SXE4/A,SXE8,SXE8/A,SXQ4,SXQ4/A,SXU,SXU/A S1,S1/A
	90745-ZE2-600	KEY, 6.3X6.3X43	1	(1)	-	-----	QA,QAB1,QAB3,QAB3/A,QAE,QAE2,QAE2/A,QAE6,QAE6/A,QAG,QAG/A,QAG2 QAG2/A,QAQ,QAQ4,QAQ4/A,QAW,QAW/A,QA2,QA2/A,QD,QD/A,QE,QE/A,QH QH/A,QHB5,QHC,QHE,QHE4,QHE4/A,QHP1,QHP1/A,QHQ4,QHQ4/A,QHR,QHR/A QHR4,QHR4/A,QHZ,QHZ/A,QH26,QH26/A,QKE3,QKE3/A,QKE4,QME2,QME2/A QMH,QMH/A,QP,QP/A,QSC,QSC9,QSC9/A,QSE,QSE/A,QSE2,QSE8,QSE8/A,QT QT/A,QWA2,QWA4,QWA4/A,QWH2,QWH2/A,QX,QX/A,QXB,QXB/A,QXB7,QXB7/A QXC,QXC4,QXC4/A,QXC6,QXC6/A,QXC9,QXC9/A,QXE,QXE/A,QXEB,QXE4 QXE4/A,QXE6,QXE6/A,QXE8,QXE8/A,QXQ4,QXQ4/A,QXU,QXU/A,QX26,QX26/A Q1,Q1/A,Q2,VME2,VME2/A,VMS2
13	91001-ZH9-003	BEARING, RADIAL BALL (6206 SH)	1	1	1	-----	ESS,ESS/A,ES1,ES1/A,ES3,ES3/A,VMA4,VME4,VMT,VMT/A
14	13310-ZH9-700	CRANKSHAFT COMP.	1	-	-	-----	HA,HAP,HAP/A,HAQ,HA2,HA2/A,HEA,HEA2,HEA2/A,HEA8,HEA8/A,LSS,LTJ LWD1,LWD1/A,PA,PAE2,PAE2/A,PA2,PA2/A,QA,QAB1,QAB3,QAB3/A,QAE,QAE2 QAE2/A,QAE6,QAE6/A,QAG,QAG/A,QAQ,QAQ4,QAQ4/A,QAR2,QAR2/A,QAW QAW/A,QA2,QA2/A,QL2,QSC,QSC9,QSC9/A,QXB6,QXB6/A,QX26,QX26/A,Q2,RA RA2,RA2/A,RSC2,RSC2/A,RSS,RSS/A,SK,VA,VAW,VAW1,VA2,VA2/A,VDE,VDE2 VDE2/A,VKB2,VKB2/A,VME2,VME2/A,VMS2,VMX2,VM2,VM2/A,VNT2,VNT2/A VWA,VWA2,VWA2/A,VWN2,VWN2/A,VW12,VW12/A,VW22
15	13351-ZE2-010	WEIGHT, BALANCER	1	(1)	1	-----	



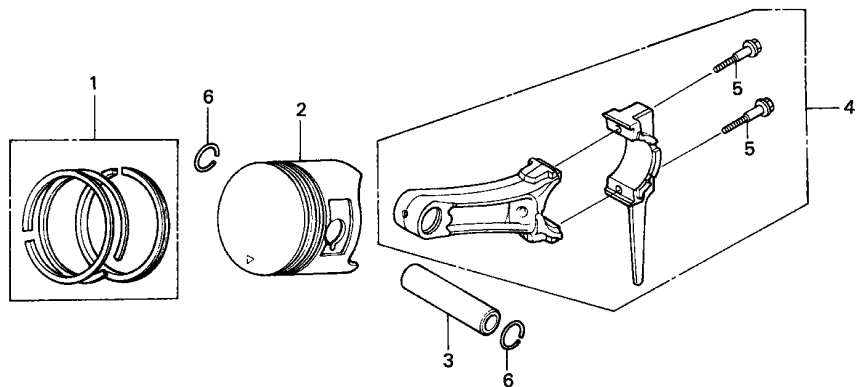

ZH90-E0800A

Ref. No.	L.O.N.	(Relative ref. Number) Description	F.R.T.
2		(1,3,4)	
1111R1		PISTON AND/OR RING SET AND/OR BEARING AND/OR RODINCLUDES: Inspection/ Measurement/Cleaning	1.2

Ref. No.	Part No.	Description	Reqd. QTY			Serial No.	Parts catalogue code
			(1)	(2)	(3)		
1	13010-ZE8-601	RING SET, PISTON (STD.) (NIPPON)	1	1	1		
	13010-ZE8-602	RING SET, PISTON (STD.) (TEIKOKU)	1	1	1		
	13011-ZE8-601	RING SET, PISTON (0.25) (NIPPON)	(1)	(1)	(1)		
	13011-ZE8-602	RING SET, PISTON (0.25) (TEIKOKU)	(1)	(1)	(1)		
	13012-ZE8-601	RING SET, PISTON (0.50) (NIPPON)	(1)	(1)	(1)		
	13012-ZE8-602	RING SET, PISTON (0.50) (TEIKOKU)	(1)	(1)	(1)		
	13013-ZE8-601	RING SET, PISTON (0.75) (NIPPON)	(1)	(1)	(1)		
	13013-ZE8-602	RING SET, PISTON (0.75) (TEIKOKU)	(1)	(1)	(1)		
2	13101-ZE8-810	PISTON (E=7.1)	1	-	-	----- QT,QT/A,SN,SN/A	

Ref. No.	Part No.	Description	Reqd. QTY			Serial No.	Parts catalogue code
			(1)	(2)	(3)		
(2)	13101-ZH9-000	PISTON (STD.)	1	-	-	-----	ESS,ESS/A,ES1,ES1/A,ES3,ES3/A,HA,HAQ,HA2,HA2/A,HEA,HEA2,HEA2/A,HEA8,HEA8/A,HH,HX,HX/A,HXQ4,HXQ4/A,HX26,HX26/A,HX8,HX8/A,LH,LH/A,LHB1,LHB3,LHB5,LHE,LHE/A,LHQ4,LJ,LJ/A,LJC,LJC/A,LJG,LJG/A,LSS,LT,LT/A,LTJ,LW,LW/A,LWD,LWD1,LWD1/A,LX,LX/A,LXE,LXE/A,LXE8,LXE8/A,LXQ4,LXQ4/A,LXU,LXU/A,LXZ,LX16,PA,PAE2,PAE2/A,PA2,PA2/A,PX,PX/A,PXE8,PXE8/A,PXU,PXU/A,PX26,PX26/A,QA,QAB1,QAB3,QAB3/A,QAE,QAE2,QAE2/A,QAE6,QAE6/A,QAG,QAG/A,QAG2,QAG2/A,QAQ,QAQ4,QAQ4/A,QAR2,QAR2/A,QAW,QAW/A,QA2,QA2/A,QD,QD/A,QE,QE/A,QH,QH/A,QHB5,QHC,QHE,QHE4,QHE4/A,QHP1,QHP1/A,QHQ4,QHQ4/A,QHR,QHR/A,QHR4,QHR4/A,QHZ,QHZ/A,QH26,QH26/A,QKE3,QKE3/A,QKE4,QL2,QME2,QME2/A,QMH,QMH/A,QP,QP/A,QSC,QSC9,QSC9/A,QSE,QSE/A,QSE2,QSE8,QSE8/A,QWA2,QWA4,QWA4/A,QWH2,QWH2/A,QX,QX/A,QXB,QXB/A,QXB6,QXB6/A,QXB7,QXB7/A,QXC,QXC4,QXC4/A,QXC6,QXC6/A,QXC9,QXC9/A,QXE,QXE/A,QXEB,QXE4,QXE4/A,QXE6,QXE6/A,QXE8,QXE8/A,QXQ4,QXQ4/A,QXU,QXU/A,QX26,QX26/A,RA,RA2,RA2/A,RD,RD/A,RH,RHE,RHE4,RHE4/A,RHQ4,RHQ4/A,RH26,RH26/A,RSC2,RSC2/A,RSS,RSS/A,RX,RX/A,RXQ4,RXQ4/A,RXU,RXU/A,SD,SD/A,SE,SE/A,SH,SH/A,SHE,SHEZ,SHQ4,SHQ4/A,SJ,SJ/A,SJG,SJG/A,SJP,SK,SKE1,SMC4,SMC4/A,SMD,SME1,SME1/A,SME6,SME6/A,SMX2,SW,SWA4,SWC4,SWC4/A,SWE,SX,SX/A,SXB,SXB/A,SXB7,SXB7/A,SXE,SXE/A,SXEB,SXEB/A,SXE4,SXE4/A,SXE8,SXE8/A,SXQ4,SXQ4/A,SXU,SXU/A,SX2,VA,VAG2,VAG2/A,VAW,VAW1,VA2,VA2/A,VDE,VDE2,VDE2/A,VD16,VEB6,VH,VKB2,VKB2/A,VKE4,VKX4,VMA4,VME2,VME2/A,VME4,VMS2,VMT,VMT/A,VMX2,VM2,VM2/A,VNG1,VNG1/A,VNT2,VNT2/A,VN17,VN17/A,VPE4,VPE4/A,VPE5,VPE7,VPE7/A,VPX4,VPX4/A,VPX5,VPX7,VPX7/A,VSD,VSD/A,VSD3,VSD3/A,VSD7,VSD7/A,VSH7,VS3,VS37,VS37/A,VWA,VWA2,VWA2/A,VWN2,VWN2/A,VWT4,VWT4/A,VW12,VW12/A,VW22,VX,VX/A,VXB,VXB/A,VXB2,VXB6,VXB7,VXB7/A,VXE,VXEB,VXEB/A,VXE4,VXE4/A,VXE6,VXE6/A,VXE7,VXE7/A,VXG,VXQ4,VXQ4/A,VXTB,VXT1,VXT1/A,VXU,VXU/A,VXU1,VXU1/A,VX26,WMA4,WMT8,WMT8/A,WXE8,WXE8/A
			-	1	1		
	13102-ZH9-000	PISTON (0.25)	(1)	(1)	(1)		
	13103-ZH9-000	PISTON (0.50)	(1)	(1)	(1)		
	13104-ZH9-000	PISTON (0.75)	(1)	(1)	(1)		
3	13111-ZE2-000	PIN, PISTON	1	1	1		
4	13200-ZE2-010	ROD ASSY., CONNECTING (STD.)	1	1	1		
	13200-ZE2-305	ROD ASSY., CONNECTING (0.25 UNDER SIZE)	(1)	(1)	(1)		
5	90001-ZE8-000	BOLT, CONNECTING ROD	2	2	2		
6	90551-ZE1-000	CLIP, PISTON PIN, 18MM	2	2	2		



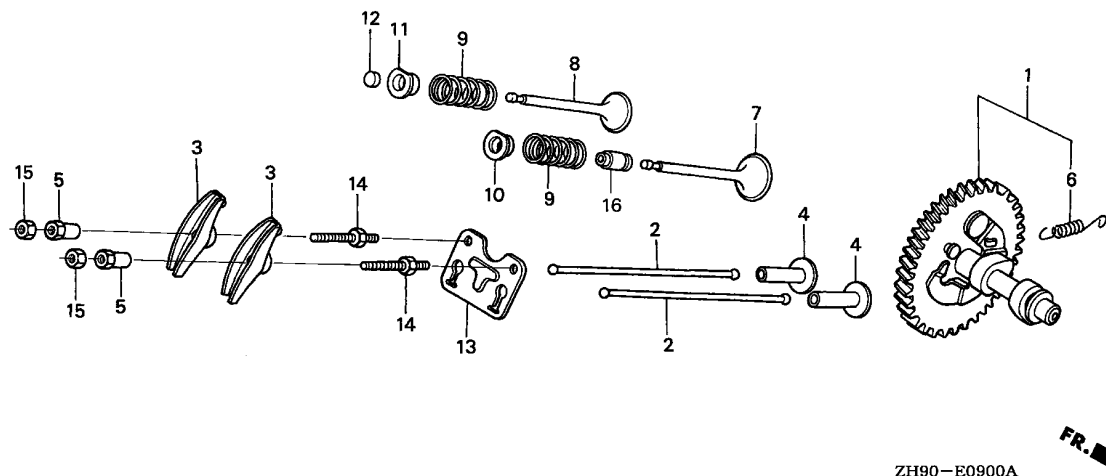

ZH90-E0900A

Ref. No.	L.O.N.	(Relative ref. Number) Description	F.R.T.
1	1111C2	CAMSHAFT .INCLUDES: Valve clearance adjustment	0.4
2	1111L6	ROD, PUSH :INTAKE .INCLUDES: Valve clearance adjustment	0.2
	1111L6A	.Replace exhaust push rod add	0.1
	1111L7	ROD, PUSH :EXHAUST .INCLUDES: Valve clearance adjustment	0.2
	1111L7A	.Replace intake push rod add	0.1
3	1111A2	ARM, ROCKER :INTAKE .INCLUDES: Valve clearance adjustment	0.2
	1111A2A	.Replace exhaust rocker arm add	0.1
	1111A1	ARM, ROCKER :EXHAUST .INCLUDES: Valve clearance adjustment	0.2
	1111A1A	.Replace intake rocker arm add	0.1
4	1111L9	LIFTER, VALVE :INTAKE .NOTE: Same time for two units	0.4
	1111M0	LIFTER, VALVE :EXHAUST .NOTE: Same time for two units	0.4
+ 7	1111L1	VALVE, INTAKE	0.7

Ref. No.	Part No.	Description	Reqd. QTY			Serial No.	Parts catalogue code
			(1)	(2)	(3)		
1	14100-ZH9-000	CAMSHAFT ASSY.	1	1	-	1268284	ESS,HA,HEA,HH,HX,HXQ4,LH,LHB1,LHB3,LHE,LHQ4,LJ,LJG,LSS,LTJ,LW,LWD,LX,LXE,LXQ4,LXZ,L1,PA,PX,QA,QAB1,QAB3,QAE,QAQ4,QD,QE,QH,QHC,QHE,QHE4,QHP1,QHQ4,QHZ,QME2,QMH,QP,QSC,QSE,QT,QX,QXB,QXC,QXC4,QXE,QXEB,QXE4,QXQ4,Q1,Q2,RA,RD,RH,RHE,RHE4,RHQ4,RX,RXQ4,R1,SD,SE,SH,SHE,SHEZ,SHQ4,SJ,SJG,SJP,SK,SMC4,SMD,SME1,SME6,SN,SW,SWC4,SWE,SX,SXB,SXE,SXEB,SXE4,SXQ4,S1,VA,VAW,VAW1,VDE,VH,VNG1,VSD,VSD3,VVA,VWT4,VX,VXB,VXE,VXEB,VXE4,VXG,VXQ4,VXU,V1,W1
	14100-ZH9-010	-	-	1	1000029	VXP,VXQP
		1	1	1	1268285	ESS/A,ES1,ES1/A,ES3,ES3/A,LJ/A,LJC,LJC/A,LJG/A,LT,LT/A,LW/A,LWD1,LWD1/A,L1/A,QD/A,QE/A,QKE3,QKE3/A,QP/A,QT/A,QXC4/A,Q1/A,RD/A,RXP,RXP/A,R1/A,SD/A,SE/A,SJ/A,SJG/A,SKE1,SMC4/A,SME6/A,SN/A,S1/A,VKE4,VKX4,VMT,VMT/A,VPE4,VPE4/A,VPE5,VPX4,VPX4/A,VPX5,VSD3/A,VS3,VWT4/A,VXP/A,VXT1,VXT1/A,W1/A
		1	1	-	1268285	ESS,HA,HEA,HH,LHB1,LHB3,LHQ4,LJ,LJG,LSS,LTJ,LW,LWD,LXZ,L1,PA,QA,QAB1,QAE,QD,QE,QHC,QHE,QP,QSC,QT,QXC,QXC4,QXEB,Q1,Q2,RA,RD,RHE,R1,SD,SE,SHE,SHEZ,SJ,SJG,SJP,SK,SMC4,SME6,SN,SW,SWE,S1,VA,VAW,VAW1,VSD3,VVA,VWT4,V1,W1
		1	-	-	1445376	WMT8
		1	-	-	1471451	HX8,LXE8,LXU,PXU,QSE8,QXE8,QXU,RXU,SXE8,SXU,VXTB,VXU1
		1	-	-	1268285	SWC4
		1	-	-	1268285	1471451 HX,HXQ4,LH,LHE,LX,LXE,LXQ4,PX,QAB3,QAQ4,QH,QHE4,QHP1,QHQ4,QHZ,QME2,QMH,QSE,QX,QXB,QXE,QXE4,QXQ4,RH,RHE4,RHQ4,RX,RXQ4,SH,SHQ4,SMD,SME1,SX,SXB,SXE,SXEB,SXE4,SXQ4,VDE,VH,VNG1,VSD,VX,VXB,VXE,VXEB,VXE4,VXG,VXQ4,VXU
		-	-	1	1000030	VXP,VXQP
	14100-ZE3-010	1	-	-	1267906	HAQ,HA2,HEA2,HX26,LX16,PAE2,PA2,PX26,QAE2,QAE6,QAQ,QAR2,QA2,QH26,QSC9,QXB6,QXC6,QXC9,QXE6,QX26,RA2,RH26,RSC2,SX2,VA2,VDE2,VD16,VEB6,VME2,VM2,VWA2,VWN2,VW12,VW22,VXB2,VXB6,VX26

E-9

CAMSHAFT

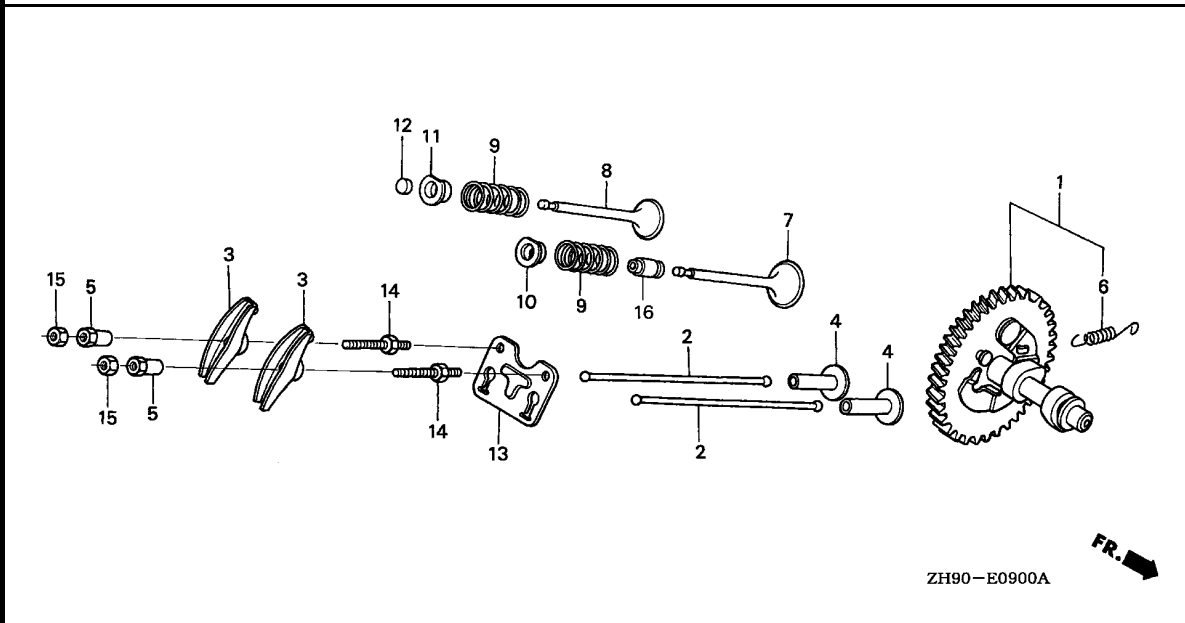

Ref. No.	L.O.N.	(Relative ref. Number) Description	F.R.T.
+ 7		.INCLUDES: Valve clearance adjustment and reface	
1111L1E		.Replace intake and exhaust all add	0.1
8 1111L0		VALVE, EXHAUST	0.7
		.INCLUDES: Valve clearance adjustment and reface	
1111L0E		.Replace intake and exhaust all add	0.1
9 1111P3		SPRING, VALVE :INTAKE	0.6
		.INCLUDES: Valve clearance adjustment	
1111P3A		.Replace intake and exhaust all add	0.1
1111P4		SPRING, VALVE :EXHAUST	0.6
		.INCLUDES: Valve clearance adjustment	
1111P4A		.Replace intake and exhaust all add	0.1
12 1111J7		ROTATOR, VALVE	0.2
		.INCLUDES: Valve clearance adjustment	
16 1111K2		SEAL, INTAKE VALVE STEM	0.6
		.INCLUDES: Valve clearance adjustment	

Ref. No.	Part No.	Description	Reqd. QTY			Serial No.	Parts catalogue code	
			(1)	(2)	(3)			
(1)	14100-ZE3-020	CAMSHAFT ASSY.	1	-	1	-----	HAP, HAP/A, HA2/A, HEA2/A, HEA8, HEA8/A, HX/A, HXQ4/A, HX26/A, HX8/A, LH/A, LHB5, LHE/A, LX/A, LXE/A, LXE8/A, LXQ4/A, LXU/A, PAE2/A, PA2/A, PX/A, PXE8, PXE8/A, PXU/A, PX26/A, QAB3/A, QAE2/A, QAE6/A, QAG, QAG/A, QAG2, QAG2/A, QAQ4/A, QAR2/A, QAW, QAW/A, QAZ/A, QH/A, QHB5, QHE4/A, QHP1/A, QHQ4/A, QHR, QHR/A, QHR4, QHR4/A, QHZ/A, QH26/A, QKE4, QL2, QME2/A, QMH/A, QSC9/A, QSE/A, QSE2, QSE8/A, QWA2, QWA4, QWA4/A, QWH2, QWH2/A, QX/A, QXB/A, QXB6/A, QXC6/A, QXC9/A, QXE/A, QXE4/A, QXE6/A, QXE8/A, QXQ4/A, QXU/A, QX26/A, RA2/A, RHE4/A, RHQ4/A, RH26/A, RSC2/A, RSS, RSS/A, RX/A, RXQ4/A, RXU/A, SH/A, SHQ4/A, SME1/A, SMX2, SWA4, SWC4/A, SX/A, SXB/A, SXE/A, SXEB/A, SXE4/A, SXE8/A, SXQ4/A, SXU/A, VAG2, VAG2/A, VA2/A, VDE2/A, VKB2, VKB2/A, VMA4, VME2/A, VME4, VMS2, VMX2, VM2/A, VNG1/A, VNT2, VNT2/A, VSD/A, VWA2/A, VWN2/A, VW12/A, VX/A, VXB/A, VXEB/A, VXE4/A, VXE6, VXE6/A, VXQ4/A, VXU/A, VXU1/A, WMA4, WMT8/A, WXE8, WXE8/A	
			1	-	-	1267907	-----	HAQ, HA2, HEA2, HX26, LX16, PAE2, PA2, PX26, QAE2, QAE6, QAG, QAR2, QAZ, QH26, QSC9, QXB6, QXC6, QXC9, QXE6, QX26, RA2, RH26, RSC2, SX2, VA2, VDE2, VD16, VEB6, VME2, VM2, VWA2, VWN2, VW12, VW22, VXB2, VXB6, VX26
			1	-	-	1340170	-----	SWC4
			1	-	-	1445377	-----	WMT8
			1	-	-	1471452	-----	HX, HXQ4, HX8, LH, LHE, LX, LXE, LXE8, LXQ4, LXU, PX, PXU, QAB3, QAQ4, QH, QHE4, QHP1, QHQ4, QHZ, QME2, QMH, QSE, QSE8, QX, QXB, QXE4, QXE8, QXQ4, QXU, RH, RHE4, RHQ4, RX, RXQ4, RXU, SH, SHQ4, SMD, SME1, SX, SXB, SXE, SXEB, SXE4, SXE8, SXQ4, SXU, VDE, VH, VNG1, VSD, VX, VXB, VXE, VXEB, VXE4, VXG, VXQ4, VXTB, VXU, VXU1
	14100-ZK3-870	1	-	-	-----	-----	QXB7, QXB7/A, SXB7, SXB7/A, VN17, VN17/A, VSD7, VSD7/A, VSH7, VXB7, VXB7/A, VXE7, VXE7/A
	14100-ZK9-870	1	-	-	-----	-----	VPE7, VPE7/A, VPX7, VPX7/A, VS37, VS37/A
2	14410-ZE2-013	ROD, PUSH	2	2	2			
3	14431-ZE2-010	ARM, VALVE ROCKER	2	2	2			
4	14441-ZE2-000	LIFTER, VALVE	2	2	2			



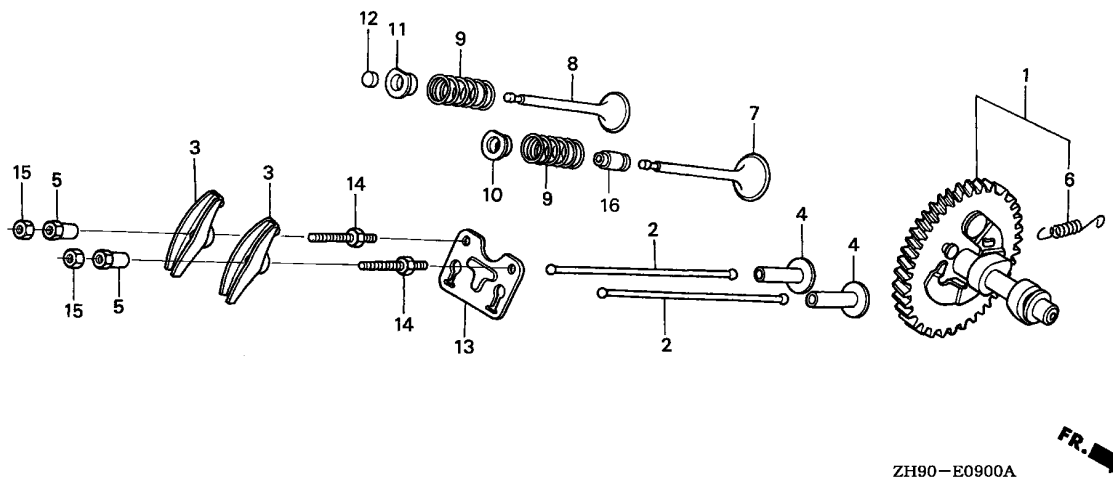

ZH90-E0900A

Ref. No.	Part No.	Description	Reqd. QTY			Serial No.	Parts catalogue code
			(1)	(2)	(3)		
			GX270				
5	14451-ZE1-013	PIVOT, ROCKER ARM	2	2	2		
6	14568-ZE1-000	SPRING, WEIGHT RETURN	1	1	1		
7	14711-ZE2-000	VALVE, IN.	1	1	-		
	14711-ZE2-W00	-	-	1		
8	14721-ZE2-000	VALVE, EX.	1	(1)	-		
	14721-ZE2-810	VALVE, EX. (STELLITE)	-	(1)	-		
	14721-ZE2-W00	-	-	1		
9	14751-ZE2-003	SPRING, VALVE	2	2	2		
10	14771-ZE2-000	RETAINER, IN. VALVE SPRING ..	1	1	1		
11	14773-ZE2-000	RETAINER, EX. VALVE SPRING ..	1	1	-		
	14771-ZE2-000	RETAINER, IN. VALVE SPRING ..	-	-	1		
12	14781-ZE2-000	ROTATOR, VALVE	1	1	-		
13	14791-ZE2-010	PLATE, PUSH ROD GUIDE	1	1	1		
14	90012-ZE0-010	BOLT, PIVOT, 8MM	2	2	2		
15	90206-ZE1-000	NUT, PIVOT ADJUSTING	2	2	2		

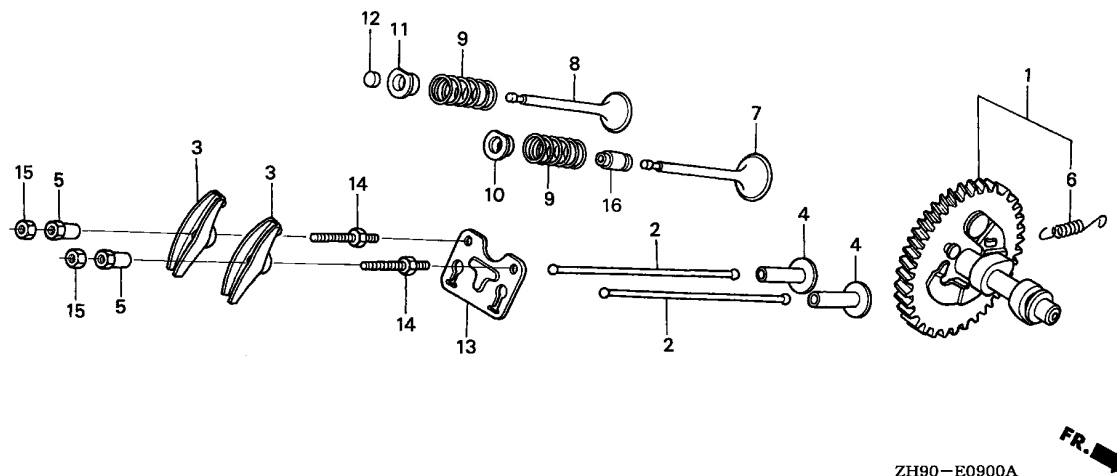

Ref. No.	Part No.	Description	Reqd. QTY			Serial No.	Parts catalogue code
			(1)	(2)	(3)		
16	12209-ZE8-003	SEAL, VALVE STEM	1	1	-	-----	ESS/A,ES1/A,ES3/A,HA2/A,HEA2/A,HEA8/A,HX/A,HXQ4/A,HX26/A,HX8/A,LH/A,LHB5/LHE/A,LJ/A,LJC/A,LJG/A,LT/A,LW/A,LWD1/A,LX/A,LXE/A,LXE8/A,LXQ4/A,LXU/A,L1/A,PAE2/A,PA2/A,PX/A,PXE8/A,PXU/A,PX26/A,QAB3/A,QAE2/A,QAE6/A,QAG,QAG/A,QAG2,QAG2/A,QAQ4/A,QAR2/A,QAW/A,QA2/A,QD/A,QE/A,QH/A,QHB5,QHE4/A,QHP1/A,QHQ4/A,QHR/A,QHR4/A,QHZ/A,QH26/A,QKE3/A,QKE4,QME2/A,QMH/A,QP/A,QSC9/A,QSE/A,QSE2,QSE8/A,QT/A,QWA4/A,QWH2,QWH2/A,QX/A,QXB/A,QXB6/A,QXB7/A,QXC4/A,QXC6/A,QXC9/A,QXE/A,QXE4/A,QXE6/A,QXE8/A,QXQ4/A,QXU/A,QX26/A,Q1/A,RA2/A,RD/A,RHE4/A,RHQ4/A,RH26/A,RSC2/A,RSS/A,RX/A,RXQ4/A,RXU/A,R1/A,SD/A,SE/A,SH/A,SHQ4/A,SJ/A,SJG/A,SMC4/A,SME1/A,SME6/A,SMX2/SN/A,SWA4,SWC4/A,SX/A,SXB/A,SXB7/A,SXB7/A,SXE/A,SXEB/A,SXE4/A,SXE8/A,SXQ4/A,SXU/A,S1/A,VAG2,VAG2/A,VA2/A,VDE2/A,VKB2/A,VKE4/VKX4,VMA4,VME2/A,VME4,VMS2,VMT/A,VMX2,VM2/A,VNG1/A,VNT2/A,VN17/VN17/A,VP4/A,VP5,A,VP6/A,VP7/A,VPX4/A,VPX5,VPX7,VPX7/A,VSD/A,VSD3/A,VSD7,VSD7/A,VSH7,VS3,VS37,VS37/A,VWA2/A,VWN2/A,VWT4/A,VW12/A,VX/A,VXB/A,VXB7/VXB7/A,VXEB/A,VXE4/A,VXE6/A,VXE7/VXE7/A,VXQ4/A,VXT1/A,VXU/A,VXU1/A,WMA4,WMT8/A,WXE8/A,W1/A
			1	1	-	1703119 -----	ESS,ES1,ES3,HA2,HEA2,HEA8,HX,HXQ4,HX26,HX8,LH,LHE,LJ,LJC,LJG,LT,LW,LWD,LWD1,LX,LXE,LXE8,LXQ4,LXU,L1,PAE2,PA2,PX,PXE8,PXU,PX26,QAB3,QAE2,QAE6,QAQ4,QAR2,QAW,QA2,QD,QE,QH,QHE4,QHP1,QHQ4,QHR,QHR4,QHZ,QH26,QKE3,QL2,QME2,QMH,QP,QSC9,QSE,QSE8,QT,QWA2,QWA4,QX,QXB,QXB6,QXC4,QXC6,QXC9,QXE,QXE4,QXE6,QXE8,QXQ4,QXU,QX26,Q1,RA2,RD,RHE4,RHQ4,RH26,RSC2,RSS,RX,RXQ4,RXU,R1,SD,SE,SH,SHQ4,SJ,SJG,SKE1,SMC4,SME1,SME6,SN,SWC4,SX,SXB,SXE,SXEB,SXE4,SXE8,SXQ4,SXU,S1,VA2,VDE2,VKB2,VME2,VMT,VM2,VNG1,VNT2,VPE4,VPX4,VSD,VSD3,VWA2,VWN2,VWT4,VW12,VX,VXB,VXEB,VXE4,VXE6,VXQ4,VXTB,VXT1,VXU,VXU1,WMT8,WXE8,W1
			-	-	1		

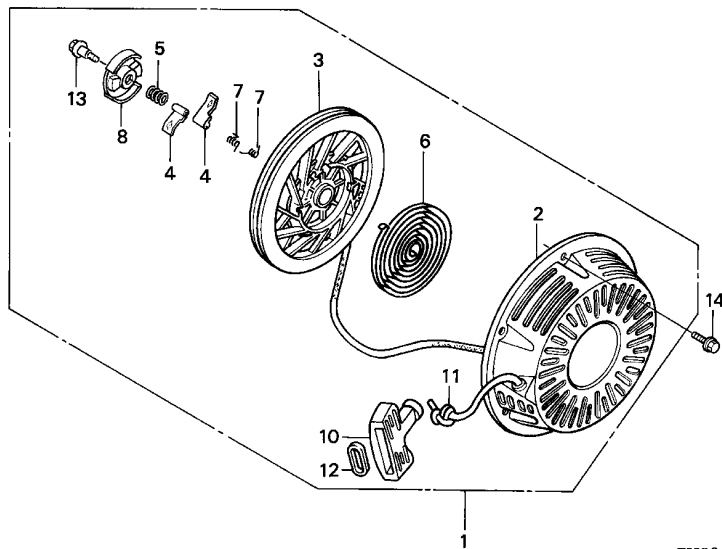

ZH90-E11008

Ref. No.	L.O.N.	(Relative ref. Number) Description	F.R.T.
1	1121B9	STARTER, RECOIL	0.1
3	1121B1	REEL, RECOIL STARTER	0.3
4	1121B0	RATCHET, STARTER AND/OR SPRING, RATCHET	0.2
6	1121B7	SPRING, RECOIL STARTER RETURN	0.3
8	1121B2	RETAINER, SPRING	0.2
11	1121B3	ROPE, RECOIL STARTER	0.3

2

Ref. No.	Part No.	Description	Reqd. QTY	Serial No.	Parts catalogue code
			GX270 (1) (2) (3)		
1	28400-ZE2-W01ZA	STARTER ASSY., RECOIL *R8*.....BRIGHT RED	1 (1) 1	-----	ESS,ES1,ES3,HA,HAP,HAQ,HA2,HEA,HEA2,HEA8,HH,HX,HXQ4,HX26,HX8,LH,LHB1,LHB3,LHE,LHQ4,LJ,LJC,LJG,LSS,LT,LTJ,LW,LX,LXE,LXE8,LXQ4,LXU,LXZ,LX16,L1,PA,PAE2,PA2,PX,PXE8,PXU,PX26,QA,QAB1,QAB3,QAE,QAE2,QAE6,QAG,QAG2,QAQ,QAQ4,QAR2,QAW,QA2,QD,QE,QH,QHC,QHE,QHE4,QHP1,QHQ4,QHR,QHR4,QHZ,QH26,QME2,QMH,QP,QSC,QSC9,QSE,QSE8,QT,QX,QXB,QXB6,QXB7,QXC,QXC4,QXC6,QXC9,QXE,QXEB,QXE4,QXE6,QXE8,QXQ4,QXU,QX26,Q1,Q2,RA,RA2,RD,RH,RHE,RHE4,RHQ4,RH26,RSC2,RSS,RX,RXP,RXQ4,RXU,R1,SD,SE,SH,SHE,SHEZ,SHQ4,SJ,SJG,SJP,SK,SMC4,SMD,SME1,SME6,SN,SW,SWC4,SWE,SX,SXB,SXB7,SXE,SXEB,SXE4,SXE8,SXQ4,SXU,SX2,S1,VA,VAG2,VAW,VA2,VDE,VDE2,VD16,VEB6,VH,VKB2,VME2,VMT,VM2,VNG1,VNT2,VPE4,VPE7,VPX4,VPX7,VSD,VSD3,VSD7,VS37,VVA,VVN2,VWT4,VW12,VX,VXB,VXB2,VXB6,VXB7,VXE,VXEB,VXE4,VXE6,VXE7,VXG,VXP,VXQP,VXQ4,VXTB,VXT1,VXU,VXU1,VX26,V1,WMT8,WXE8,W1

Ref. No.	Part No.	Description	Reqd. QTY			Serial No.	Parts catalogue code
			(1)	(2)	(3)		
(1)	28400-ZE2-W01ZA	STARTER ASSY., RECOIL *R8*.....BRIGHT RED	1	-	-	2080023	ESS/A,ES1/A,ES3/A,HA2/A,HEA2/A,HEA8/A,HX/A,HXQ4/A,HX26/A,HX8/A LH/A,LHB5,LHE/A,LJ/A,LJC/A,LJG/A,LT/A,LW/A,LX/A,LXE/A,LXE8/A LXQ4/A,LXU/A,PAE2/A,PA2/A,PX/A,PXE8/A,PXU/A,PX26/A,QAB3/A,QAE2/A QAE6/A,QAG/A,QAG2/A,QAQ4/A,QAR2/A,QAW/A,QA2/A,QD/A,QE/A,QH/A,QHB5 QHE4/A,QHP1/A,QHQ4/A,QHR/A,QHR4/A,QHZ/A,QH26/A,QME2/A,QMH/A,QP/A QSC9/A,QSE/A,QSE2,QSE8/A,QT/A,QX/A,QXB/A,QXB6/A,QXB7/A,QXC4/A QXC6/A,QXC9/A,QXE/A,QXE4/A,QXE6/A,QXE8/A,QXQ4/A,QXU/A,QX26/A RA2/A,RD/A,RHE4/A,RHQ4/A,RH26/A,RSC2/A,RSS/A,RX/A,RXQ4/A,RXU/A SD/A,SE/A,SH/A,SHQ4/A,SJ/A,SJG/A,SMC4/A,SME1/A,SME6/A,SN/A,SWC4/A SX/A,SXB/A,SXB7/A,SXE/A,SXEB/A,SXE4/A,SXE8/A,SXQ4/A,SXU/A,VAG2/A VA2/A,VDE2/A,VKB2/A,VME2/A,VMT/A,VM2/A,VNG1/A,VNT2/A,VPE4/A VPE7/A,VPX4/A,VPX7/A,VSD/A,VSD3/A,VSD7/A,VS37/A,VWN2/A,VWT4/A VW12/A,VX/A,VXB/A,VXB7/A,VXEB/A,VXE4/A,VXE6/A,VXE7/A,VXQ4/A VXT1/A,VXU/A,VXU1/A,WMT8/A,WXE8/A
			-	(1)	-	2085591	L1/A,Q1/A,R1/A,S1/A,W1/A
			-	-	1	1100008	HAP/A,RXP/A,VXP/A
	28400-ZE2-W01ZB	*NH1*.....BLACK	1	-	-		HA,HAQ,HA2,HA2/A,PA2,PA2/A,PX,PX/A,PXU,PXU/A,QA,QAE2,QAE2/A,QAQ QAQ4,QAQ4/A,QAR2,QAR2/A,QA2,QA2/A,QL2,QWA2,QWA4,QWA4/A,QWH2 QWH2/A,QXC9,QXC9/A,RA2,RA2/A,SMX2,SWC4,SWC4/A,VA2,VA2/A,VKE4,VKX4 VMA4,VME2,VME2/A,VME4,VM2,VM2/A,VNG1,VNG1/A,VN17,VN17/A,VXE4 VXE4/A,VXE7,VXE7/A
	28400-ZE2-W01ZC	*T39*.....GEKO BLUE	1	-	-		VNG1,VNG1/A
	28400-ZE2-W01ZD	*T41*...BARTELL BLUE METALLIC	1	-	-		QA,QAQ4,QAQ4/A,QA2,QA2/A,QX26,QX26/A
	28400-ZE2-W01ZG	*NH105*...MAT BLACK (#15-#20)	1	-	-		VA,VAW1,VME2,VME2/A,VMS2,VMX2,VM2,VM2/A,VS3,VWA2,VWA2/A,VW12 VW12/A,VW22
	28400-ZE2-W01ZL	*T77*.....SEC WINE RED	1	-	-		ES1,ES1/A,ES3,ES3/A
	28400-ZE2-W01ZN	*R280*.....POWER RED	1	-	-		SWA4,VPE5,VPX5,VSH7,VS3,VWA2/A,WMA4
			1	-	-	2080024	ESS/A,ES1/A,ES3/A,HA2/A,HEA2/A,HEA8/A,HX/A,HXQ4/A,HX26/A,HX8/A LH/A,LHB5,LHE/A,LJ/A,LJC/A,LJG/A,LT/A,LW/A,LX/A,LXE/A,LXE8/A LXQ4/A,LXU/A,PAE2/A,PA2/A,PX/A,PXE8/A,PXU/A,PX26/A,QAB3/A,QAE2/A QAE6/A,QAG/A,QAG2/A,QAQ4/A,QAR2/A,QAW/A,QA2/A,QD/A,QE/A,QH/A,QHB5 QHE4/A,QHP1/A,QHQ4/A,QHR/A,QHR4/A,QHZ/A,QH26/A,QME2/A,QMH/A,QP/A QSC9/A,QSE/A,QSE2,QSE8/A,QT/A,QX/A,QXB/A,QXB6/A,QXB7/A,QXC4/A QXC6/A,QXC9/A,QXE/A,QXE4/A,QXE6/A,QXE8/A,QXQ4/A,QXU/A,QX26/A RA2/A,RD/A,RHE4/A,RHQ4/A,RH26/A,RSC2/A,RSS/A,RX/A,RXQ4/A,RXU/A SD/A,SE/A,SH/A,SHQ4/A,SJ/A,SJG/A,SMC4/A,SME1/A,SME6/A,SN/A,SWC4/A SX/A,SXB/A,SXB7/A,SXE/A,SXEB/A,SXE4/A,SXE8/A,SXQ4/A,SXU/A,VAG2/A VA2/A,VDE2/A,VKB2/A,VME2/A,VMT/A,VM2/A,VNG1/A,VNT2/A,VPE4/A VPE7/A,VPX4/A,VPX7/A,VSD/A,VSD3/A,VSD7/A,VS37/A,VWN2/A,VWT4/A VW12/A,VX/A,VXB/A,VXB7/A,VXEB/A,VXE4/A,VXE6/A,VXE7/A,VXQ4/A VXT1/A,VXU/A,VXU1/A,WMT8/A,WXE8/A
			-	(1)	-	2085592	L1/A,Q1/A,R1/A,S1/A,W1/A
			-	-	1	1100009	HAP/A,RXP/A,VXP/A



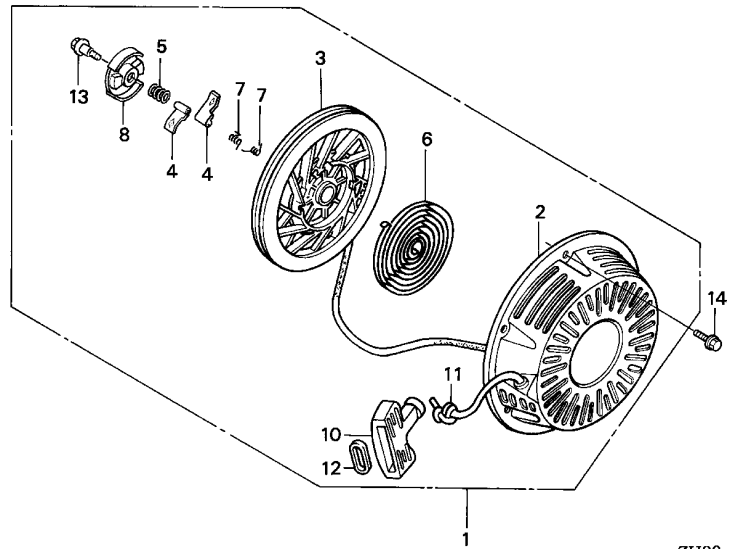

ZH90-E11008



Ref. No.	Part No.	Description	Reqd. QTY			Serial No.	Parts catalogue code
			(1)	(2)	(3)		
2	28410-ZE2-W01ZA	CASE COMP., RECOIL STARTER *R8*.....BRIGHT RED	1	(1)	1	-----	ESS,ES1,ES3,HA,HAP,HAQ,HA2,HEA,HEA2,HEA8,HH,HX,HXQ4,HX26,HX8,LH,LHB1,LHB3,LHE,LHQ4,LJ,LJC,LJG,LSS,LT,LTJ,LW,LX,LXE,LXE8,LXQ4,LXZ,LX16,L1,PA,PAE2,PA2,PX,PXE8,PXU,PX26,QA,QAB1,QAB3,QAE,QAE2,QAE6,QAG,QAG2,QAQ,QAQ4,QAR2,QAW,QA2,QD,QE,QH,QHC,QHE,QHE4,QHP1,QHQ4,QHR,QHR4,QHZ,QH26,QME2,QMH,QP,QSC,QSC9,QSE,QSE8,QT,QX,QXB,QXB6,QXB7,QXC,QXC4,QXC6,QXC9,QXE,QXEB,QXE4,QXE6,QXE8,QXQ4,QXU,QX26,Q1,Q2,RA,RA2,RD,RH,RHE,RHE4,RHQ4,RH26,RSC2,RSS,RX,RXP,RXQ4,RXU,R1,SD,SE,SH,SHE,SHEZ,SHQ4,SJ,SJG,SJP,SK,SMC4,SMD,SME1,SME6,SN,SW,SWC4,SWE,SX,SBX,SBX7,SXE,SXEB,SXE4,SXE8,SXQ4,SXU,SX2,S1,VA,VAG2,VAW,VA2,VDE,VDE2,VD16,VEB6,VH,VKB2,VME2,VMT,VM2,VNG1,VNT2,VPE4,VPE7,VPX4,VPX7,VSD,VSD3,VSD7,VS37,VVA,VVN2,VWT4,VW12,VX,VXB,VXB2,VXB6,VXB7,VXE,VXEB,VXE4,VXE6,VXE7,VXG,VXP,VXQP,VXQ4,VXTB,VXT1,VXU,VXU1,VX26,V1,WMT8,WXE8,W1

Ref. No.	Part No.	Description	Reqd. QTY			Serial No.	Parts catalogue code
			(1)	(2)	(3)		
(2)	28410-ZE2-W01ZA	CASE COMP., RECOIL STARTER *R8*.....BRIGHT RED	1	-	-	2080023	ESS/A,ES1/A,ES3/A,HA2/A,HEA2/A,HEA8/A,HX/A,HXQ4/A,HX26/A,HX8/A LH/A,LHB5,LHE/A,LJ/A,LJC/A,LJG/A,LT/A,LW/A,LX/A,LXE/A,LXE8/A LXQ4/A,LXU/A,PAE2/A,PA2/A,PX/A,PXE8/A,PXU/A,PX26/A,QAB3/A,QAE2/A QAE6/A,QAG/A,QAG2/A,QAQ4/A,QAR2/A,QAW/A,QA2/A,QD/A,QE/A,QH/A,QHB5 QHE4/A,QHP1/A,QHQ4/A,QHR/A,QHR4/A,QHZ/A,QH26/A,QME2/A,QMH/A,QP/A QSC9/A,QSE/A,QSE2,QSE8/A,QT/A,QX/A,QXB/A,QXB6/A,QXB7/A,QXC4/A QXC6/A,QXC9/A,QXE/A,QXE4/A,QXE6/A,QXE8/A,QXQ4/A,QXU/A,QX26/A RA2/A,RD/A,RHE4/A,RHQ4/A,RH26/A,RSC2/A,RSS/A,RX/A,RXQ4/A,RXU/A SD/A,SE/A,SH/A,SHQ4/A,SJ/A,SJG/A,SMC4/A,SME1/A,SME6/A,SN/A,SWC4/A SX/A,SXB/A,SXB7/A,SXE/A,SXEB/A,SXE4/A,SXE8/A,SXQ4/A,SXU/A,VAG2/A VA2/A,VDE2/A,VKB2/A,VME2/A,VMT/A,VM2/A,VNT2/A,VPE4/A,VPE7/A VPX4/A,VPX7/A,VSD/A,VSD3/A,VSD7/A,VS37/A,VWN2/A,VWT4/A,VW12/A VX/A,VXB/A,VXB7/A,VXEB/A,VXE4/A,VXE6/A,VXE7/A,VXQ4/A,VXT1/A,VXU/A VXU1/A,WMT8/A,WXE8/A
			-	(1)	-	2085591	L1/A,Q1/A,R1/A,S1/A,W1/A
			-	-	1	1100008	HAP/A,RXP/A,VXP/A
	28410-ZE2-W01ZB	*NH1*.....BLACK	1	-	-		HA,HAQ,HA2,HA2/A,PA2,PA2/A,PX,PX/A,PXU,PXU/A,QA,QAE2,QAE2/A,QAQ QAQ4,QAR2,QAR2/A,QA2,QA2/A,QL2,QWA2,QWA4,QWA4/A,QWH2,QWH2/A,QXC9 QXC9/A,RA2,RA2/A,SMX2,SWC4,SWC4/A,VA2,VA2/A,VKE4,VKX4,VMA4,VME2 VME2/A,VME4,VM2,VNG1,VNG1/A,VN17,VN17/A,VXE4,VXE4/A,VXE7,VXE7/A VNG1,VNG1/A
	28410-ZE2-W01ZC	*T39*.....GEKO BLUE	1	-	-		QA,QAQ4,QAQ4/A,QA2,QA2/A,QX26,QX26/A
	28410-ZE2-W01ZD	*T41*...BARTELL BLUE METALLIC	1	-	-		VA,VAW1,VME2,VME2/A,VMS2,VMX2,VM2,VM2/A,VS3,VWA2,VWA2/A,VW12 VW12/A,VW22
	28410-ZE2-W01ZG	*NH105*...MAT BLACK (#15-#20)	1	-	-		ES1,ES1/A,ES3,ES3/A
	28410-ZE2-W01ZL	*T77*.....SEC WINE RED	1	-	-		SWA4,VPE5,VPX5,VSH7,VS3,VWA2/A,WMA4
	28410-ZE2-W01ZN	*R280*.....POWER RED	1	-	-	2080024	ESS/A,ES1/A,ES3/A,HA2/A,HEA2/A,HEA8/A,HX/A,HXQ4/A,HX26/A,HX8/A LH/A,LHB5,LHE/A,LJ/A,LJC/A,LJG/A,LT/A,LW/A,LX/A,LXE/A,LXE8/A LXQ4/A,LXU/A,PAE2/A,PA2/A,PX/A,PXE8/A,PXU/A,PX26/A,QAB3/A,QAE2/A QAE6/A,QAG/A,QAG2/A,QAQ4/A,QAR2/A,QAW/A,QA2/A,QD/A,QE/A,QH/A,QHB5 QHE4/A,QHP1/A,QHQ4/A,QHR/A,QHR4/A,QHZ/A,QH26/A,QME2/A,QMH/A,QP/A QSC9/A,QSE/A,QSE2,QSE8/A,QT/A,QX/A,QXB/A,QXB6/A,QXB7/A,QXC4/A QXC6/A,QXC9/A,QXE/A,QXE4/A,QXE6/A,QXE8/A,QXQ4/A,QXU/A,QX26/A RA2/A,RD/A,RHE4/A,RHQ4/A,RH26/A,RSC2/A,RSS/A,RX/A,RXQ4/A,RXU/A SD/A,SE/A,SH/A,SHQ4/A,SJ/A,SJG/A,SMC4/A,SME1/A,SME6/A,SN/A,SWC4/A SX/A,SXB/A,SXB7/A,SXE/A,SXEB/A,SXE4/A,SXE8/A,SXQ4/A,SXU/A,VAG2/A VA2/A,VDE2/A,VKB2/A,VME2/A,VMT/A,VM2/A,VNT2/A,VPE4/A,VPE7/A VPX4/A,VPX7/A,VSD/A,VSD3/A,VSD7/A,VS37/A,VWN2/A,VWT4/A,VW12/A VX/A,VXB/A,VXB7/A,VXEB/A,VXE4/A,VXE6/A,VXE7/A,VXQ4/A,VXT1/A,VXU/A VXU1/A,WMT8/A,WXE8/A
			-	(1)	-	2085592	L1/A,Q1/A,R1/A,S1/A,W1/A
			-	-	1	1100009	HAP/A,RXP/A,VXP/A



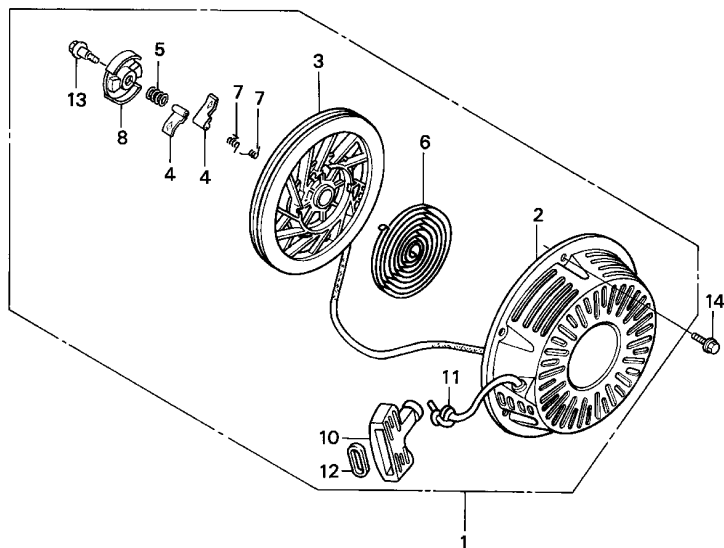

ZH90-E11008



Ref. No.	Part No.	Description	Reqd. QTY			Serial No.	Parts catalogue code
			(1)	(2)	(3)		
3	28421-ZE2-W01	PULLEY, RECOIL STARTER	1	-	-	-----	ESS,ESS/A,ES1,ES1/A,ES3,ES3/A,HA,HAQ,HA2,HA2/A,HEA,HEA2,HEA2/A,HEA8,HEA8/A,HH,HX,HX/A,HXQ4,HXQ4/A,HX26,HX26/A,HX8,HX8/A,LH,LH/A,LHB1,LHB3,LHB5,LHE,LHE/A,LHQ4,LJ,LJ/A,LJC,LJC/A,LJG,LJG/A,LSS,LT,LT/A,LTJ,LW,LW/A,LX,LX/A,LXE,LXE/A,LXE8,LXE8/A,LXQ4,LXQ4/A,LXU,LXU/A,LXZ,LX16,PA,PAE2,PAE2/A,PA2,PA2/A,PX,PX/A,PXE8,PXE8/A,PXU,PXU/A,PX26,PX26/A,QA,QAB1,QAB3,QAB3/A,QAE,QAE2,QAE2/A,QAE6,QAE6/A,QAG,QAG/A,QAG2,QAG2/A,QAQ,QAQ4,QAQ4/A,QAR2,QAR2/A,QAW,QAW/A,QA2,QA2/A,QD,QD/A,QE,QE/A,QH,QH/A,QHB5,QHC,QHE,QHE4,QHE4/A,QHP1,QHP1/A,QHQ4,QHQ4/A,QHR,QHR/A,QHR4,QHR4/A,QHZ,QHZ/A,QH26,QH26/A,QL2,QME2,QME2/A,QMH,QMH/A,QP,QP/A,QSC,QSC9,QSC9/A,QSE,QSE/A,QSE2,QSE8,QSE8/A,QT,QT/A,QWA2,QWA4,QWA4/A,QWH2,QWH2/A,QX,QX/A,QXB,QXB/A,QXB6,QXB6/A,QXB7,QXB7/A,QXC,QXC4,QXC4/A,QXC6,QXC6/A,QXC9,QXC9/A,QXE,QXE/A,QXEB,QXE4,QXE4/A,QXE6,QXE6/A,QXE8,QXE8/A,QXQ4,QXQ4/A,QXU,QXU/A,QX26,QX26/A,RA,RA2,RA2/A,RD,RD/A,RH,RHE,RHE4,RHE4/A,RHQ4,RHQ4/A,RH26,RH26/A,RSC2,RSC2/A,RSS,RSS/A,RX,RX/A,RXQ4,RXQ4/A,RXU,RXU/A,SD,SD/A,SE,SE/A,SH,SH/A,SHE,SHE2,SHQ4,SHQ4/A,SJ,SJ/A,SJG,SJG/A,SJP,SK,SMC4,SMC4/A,SMD,SME1,SME1/A,SME6,SME6/A,SMX2,SN,SN/A,SW,SWA4,SWC4,SWC4/A,SWE,SX,SX/A,SBX,SBX/A,SBX7,SBX7/A,SXE,SXE/A,SXEB,SXEB/A,SXE4,SXE4/A,SXE8,SXE8/A, SXQ4, SXQ4/A, SXU, SXU/A, SX2, VA, VAG2, VAG2/A, VAW, VAW1, VA2, VA2/A, VDE, VDE2, VDE2/A, VD16, VEB6, VH, VKB2, VKB2/A, VKE4, VKX4, VMA4, VME2, VME2/A, VME4, VMS2, VMT, VMT/A, VMX2, VM2, VM2/A, VNG1, VNG1/A, VNT2, VNT2/A, VN17, VN17/A, VPE4, VPE4/A, VPE5, VPE7, VPE7/A, VPX4, VPX4/A, VPX5, VPX7, VPX7/A, VSD, VSD/A, VSD3, VSD3/A, VSD7, VSD7/A, VSH7, VS3, VS37, VS37/A, VWA, VWA2, VWA2/A, VWN2, VWN2/A, VWT4, VWT4/A, VW12, VW12/A, VW22, VX, VX/A, VXB, VXB/A, VXB2, VXB6, VXB7, VXB7/A, VXE, VXE8, VXE8/A, VXE4, VXE4/A, VXE6, VXE6/A, VXE7, VXE7/A, VVG, VXQ4, VXQ4/A, VXTB, VXT1, VXT1/A, VXU, VXU/A, VXU1, VXU1/A, VX26, WMA4, WMT8, WMT8/A, WXE8, WXE8/A

- (1) 1

Ref. No.	Part No.	Description	Reqd. QTY			Serial No.	Parts catalogue code
			(1)	(2)	(3)		
4	28422-ZE2-W01	RATCHET, STARTER	2	-	-	-----	ESS,ESS/A,ES1,ES1/A,ES3,ES3/A,HA,HAQ,HA2,HA2/A,HEA,HEA2,HEA2/A,HEA8,HEA8/A,HH,HX,HX/A,HXQ4,HXQ4/A,HX26,HX26/A,HX8,HX8/A,LH,LH/A,LHB1,LHB3,LHB5,LHE,LHE/A,LHQ4,LJ,LJ/A,LJC,LJC/A,LJG,LJG/A,LSS,LT,LT/A,LTJ,LW,LW/A,LX,LX/A,LXE,LXE/A,LXE8,LXE8/A,LXQ4,LXQ4/A,LXU,LXU/A,LXZ,LX16,PA,PAE2,PAE2/A,PA2,PA2/A,PX,PX/A,PXE8,PXE8/A,PXU,PXU/A,PX26,PX26/A,QA,QAB1,QAB3,QAB3/A,QAQ,QAQ2,QAQ2/A,QAQ,QAQ4,QAQ4/A,QAR2,QAR2/A,QAW,QAW/A,QA2,QA2/A,QD,QD/A,QE,QE/A,QH,QH/A,QHB5,QHC,QHE,QHE4,QHE4/A,QHP1,QHP1/A,QHQ4,QHQ4/A,QHR,QHR/A,QHR4,QHR4/A,QHZ,QHZ/A,QH26,QH26/A,QL2,QME2,QME2/A,QMH,QMH/A,QP,QP/A,QSC,QSC9,QSC9/A,QSE,QSE2,QSE8,QSE8/A,QT,QT/A,QWA2,QWA4,QWA4/A,QWH2,QWH2/A,QX,QX/A,QXB,QXB/A,QXB6,QXB6/A,QXB7,QXB7/A,QXC,QXC4,QXC4/A,QXC6,QXC6/A,QXC9,QXC9/A,QXE,QXE/A,QXEB,QXE4,QXE4/A,QXE6,QXE6/A,QXE8,QXE8/A,QXQ4,QXQ4/A,QXU,QXU/A,QX26,QX26/A,RA,RA2,RA2/A,RD,RD/A,RH,RHE,RHE4,RHE4/A,RHQ4,RHQ4/A,RH26,RH26/A,RSC2,RSC2/A,RSS,RSS/A,RX,RX/A,RXQ4,RXQ4/A,RXU,RXU/A,SD,SD/A,SE,SE/A,SH,SH/A,SHE,SHEZ,SHQ4,SHQ4/A,SJ,SJ/A,SJG,SJG/A,SJP,SK,SMC4,SMC4/A,SMD,SME1,SME1/A,SME6,SME6/A,SMX2,SN,SN/A,SW,SWA4,SWC4,SWC4/A,SWE,SX,SX/A,SBX,SBX/A,SBX7,SBX7/A,SXE,SXE/A,SXEB,SXEB/A,SXE4,SXE4/A,SXE8,SXE8/A, SXQ4, SXQ4/A, SXU, SXU/A, SX2, VA, VAG2, VAG2/A, VAW, VAW1, VA2, VA2/A, VDE, VDE2, VDE2/A, VD16, VEB6, VH, VKB2, VKB2/A, VKE4, VKX4, VMA4, VME2, VME2/A, VME4, VMS2, VMT, VMT/A, VMX2, VM2, VM2/A, VNG1, VNG1/A, VNT2, VNT2/A, VN17, VN17/A, VPE4, VPE4/A, VPE5, VPE7, VPE7/A, VPX4, VPX4/A, VPX5, VPX7, VPX7/A, VSD, VSD/A, VSD3, VSD3/A, VSD7, VSD7/A, VSH7, VS3, VS37, VS37/A, VWA, VWA2, VWA2/A, VWN2, VWN2/A, VWT4, VWT4/A, VW12, VW12/A, VW22, VX, VX/A, VXB, VXB/A, VXB2, VXB6, VXB7, VXB7/A, VXE, VXE8, VXE8/A, VXE4, VXE4/A, VXE6, VXE6/A, VXE7, VXE7/A, VXG, VXQ4, VXQ4/A, VXTB, VXT1, VXT1/A, VXU, VXU/A, VXU1, VXU1/A, VX26, WMA4, WMT8, WMT8/A, WXE8, WXE8/A
5	28441-ZE2-W01	SPRING, FRICTION	1	(2)	2	-----	ESS,ESS/A,ES1,ES1/A,ES3,ES3/A,HA,HAQ,HA2,HA2/A,HEA,HEA2,HEA2/A,HEA8,HEA8/A,HH,HX,HX/A,HXQ4,HXQ4/A,HX26,HX26/A,HX8,HX8/A,LH,LH/A,LHB1,LHB3,LHB5,LHE,LHE/A,LHQ4,LJ,LJ/A,LJC,LJC/A,LJG,LJG/A,LSS,LT,LT/A,LTJ,LW,LW/A,LX,LX/A,LXE,LXE/A,LXE8,LXE8/A,LXQ4,LXQ4/A,LXU,LXU/A,LXZ,LX16,PA,PAE2,PAE2/A,PA2,PA2/A,PX,PX/A,PXE8,PXE8/A,PXU,PXU/A,PX26,PX26/A,QA,QAB1,QAB3,QAB3/A,QAQ,QAQ2,QAQ2/A,QAQ,QAQ4,QAQ4/A,QAR2,QAR2/A,QAW,QAW/A,QA2,QA2/A,QD,QD/A,QE,QE/A,QH,QH/A,QHB5,QHC,QHE,QHE4,QHE4/A,QHP1,QHP1/A,QHQ4,QHQ4/A,QHR,QHR/A,QHR4,QHR4/A,QHZ,QHZ/A,QH26,QH26/A,QL2,QME2,QME2/A,QMH,QMH/A,QP,QP/A,QSC,QSC9,QSC9/A,QSE,QSE/A,QSE2,QSE8,QSE8/A,QT,QT/A,QWA2,QWA4,QWA4/A,QWH2,QWH2/A,QX,QX/A,QXB,QXB/A,QXB6,QXB6/A,QXB7,QXB7/A,QXC,QXC4,QXC4/A,QXC6,QXC6/A,QXC9,QXC9/A,QXE,QXE/A,QXEB,QXE4,QXE4/A,QXE6,QXE6/A,QXE8,QXE8/A,QXQ4,QXQ4/A,QXU,QXU/A,QX26,QX26/A,RA,RA2,RA2/A,RD,RD/A,RH,RHE,RHE4,RHE4/A,RHQ4,RHQ4/A,RH26,RH26/A,RSC2,RSC2/A,RSS,RSS/A,RX,RX/A,RXQ4,RXQ4/A,RXU,RXU/A,SD,SD/A,SE,SE/A,SH,SH/A,SHE,SHEZ,SHQ4,SHQ4/A,SJ,SJ/A,SJG,SJG/A,SJP,SK,SMC4,SMC4/A,SMD,SME1,SME1/A,SME6,SME6/A,SMX2,SN,SN/A,SW,SWA4,SWC4,SWC4/A,SWE,SX,SX/A,SBX,SBX/A,SBX7,SBX7/A,SXE,SXE/A,SXEB,SXEB/A,SXE4,SXE4/A,SXE8,SXE8/A, SXQ4, SXQ4/A, SXU, SXU/A, SX2, VA, VAG2, VAG2/A, VAW, VAW1, VA2, VA2/A, VDE, VDE2, VDE2/A, VD16, VEB6, VH, VKB2, VKB2/A, VKE4, VKX4, VMA4, VME2, VME2/A, VME4, VMS2, VMT, VMT/A, VMX2, VM2, VM2/A, VNG1, VNG1/A, VNT2, VNT2/A, VN17, VN17/A, VPE4, VPE4/A, VPE5, VPE7, VPE7/A, VPX4, VPX4/A, VPX5, VPX7, VPX7/A, VSD, VSD/A, VSD3, VSD3/A, VSD7, VSD7/A, VSH7, VS3, VS37, VS37/A, VWA, VWA2, VWA2/A, VWN2, VWN2/A, VWT4, VWT4/A, VW12, VW12/A, VW22, VX, VX/A, VXB, VXB/A, VXB2, VXB6, VXB7, VXB7/A, VXE, VXE8, VXE8/A, VXE4, VXE4/A, VXE6, VXE6/A, VXE7, VXE7/A, VXG, VXQ4, VXQ4/A, VXTB, VXT1, VXT1/A, VXU, VXU/A, VXU1, VXU1/A, VX26, WMA4, WMT8, WMT8/A, WXE8, WXE8/A



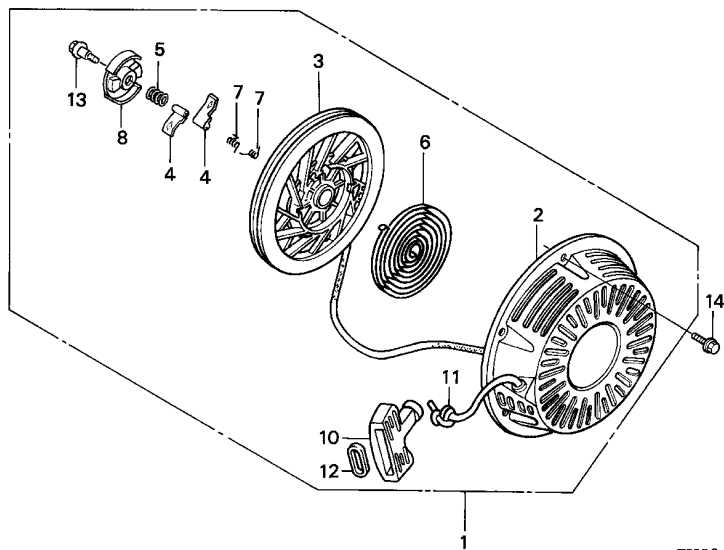

ZH90-E11008



2

Ref. No.	Part No.	Description	Reqd. QTY			Serial No.	Parts catalogue code
			(1)	(2)	(3)		
6	28442-ZE2-W01	SPRING, STARTER RETURN	1	-	-	-----	ESS,ESS/A,ES1,ES1/A,ES3,ES3/A,HA,HAQ,HA2,HA2/A,HEA,HEA2,HEA2/A,HEA8,HEA8/A,HH,HX,HX/A,HXQ4,HXQ4/A,HX26,HX26/A,HX8,HX8/A,LH,LH/A,LHB1,LHB3,LHB5,LHE,LHE/A,LHQ4,LJ,LJ/A,LJC,LJC/A,LJG,LJG/A,LSS,LT,LT/A,LTJ,LW,LW/A,LX,LX/A,LXE,LXE/A,LXE8,LXE8/A,LXQ4,LXQ4/A,LXU,LXU/A,LXZ,LX16,PA,PAE2,PAE2/A,PA2,PA2/A,PX,PX/A,PXE8,PXE8/A,PXU,PXU/A,PX26,PX26/A,QA,QAB1,QAB3,QAB3/A,QAE,QAE2,QAE2/A,QAE6,QAE6/A,QAG,QAG/A,QAG2,QAG2/A,QAQ,QAQ4,QAQ4/A,QAR2,QAR2/A,QAW,QAW/A,QA2,QA2/A,QD,QD/A,QE,QE/A,QH,QH/A,QHB5,QHC,QHE,QHE4,QHE4/A,QHP1,QHP1/A,QHQ4,QHQ4/A,QHR,QHR/A,QHR4,QHR4/A,QHZ,QHZ/A,QH26,QH26/A,QL2,QME2,QME2/A,QMH,QMH/A,QP,QP/A,QSC,QSC9,QSC9/A,QSE,QSE/A,QSE2,QSE8,QSE8/A,QT,QT/A,QWA2,QWA4,QWA4/A,QWH2,QWH2/A,QX,QX/A,QXB,QXB/A,QXB6,QXB6/A,QXB7,QXB7/A,QXC,QXC4,QXC4/A,QXC6,QXC6/A,QXC9,QXC9/A,QXE,QXE/A,QXEB,QXE4,QXE4/A,QXE6,QXE6/A,QXE8,QXE8/A,QXQ4,QXQ4/A,QXU,QXU/A,QX26,QX26/A,RA,RA2,RA2/A,RD,RD/A,RH,RHE,RHE4,RHE4/A,RHQ4,RHQ4/A,RH26,RH26/A,RSC2,RSC2/A,RSS,RSS/A,RX,RX/A,RXQ4,RXQ4/A,RXU,RXU/A,SD,SD/A,SE,SE/A,SH,SH/A,SHE,SHE2,SHQ4,SHQ4/A,SJ,SJ/A,SJG,SJG/A,SJP,SK,SMC4,SMC4/A,SMD,SME1,SME1/A,SME6,SME6/A,SMX2,SN,SN/A,SW,SWA4,SWC4,SWC4/A,SWE,SX,SX/A,SBX,SBX/A,SBX7,SBX7/A,SXE,SXE/A,SXEB,SXEB/A,SXE4,SXE4/A,SXE8,SXE8/A,SXQ4,SXQ4/A,SXU,SXU/A,SX2,VA,VAG2,VAG2/A,VAW,VAW1,VA2,VA2/A,VDE,VDE2,VDE2/A,VD16,VEB6,VH,VKB2,VKB2/A,VKE4,VKX4,VMA4,VME2,VME2/A,VME4,VMS2,VMT,VMT/A,VMX2,VM2,VM2/A,VNG1,VNG1/A,VNT2,VNT2/A,VN17,VN17/A,VPE4,VPE4/A,VPE5,VPE7,VPE7/A,VPX4,VPX4/A,VPX5,VPX7,VPX7/A,VSD,VSD/A,VSD3,VSD3/A,VSD7,VSD7/A,VSH7,VS3,VS37,VS37/A,VVA,VVA2,VVA2/A,VWN2,VWN2/A,VWT4,VWT4/A,VW12,VW12/A,VW22,VX,VX/A,VXB,VXB/A,VXB2,VXB6,VXB7,VXB7/A,VXE,VXEB,VXEB/A,VXE4,VXE4/A,VXE6,VXE6/A,VXE7,VXE7/A,VXG,VXQ4,VXQ4/A,VXTB,VXT1,VXT1/A,VXU,VXU/A,VXU1,VXU1/A,VX26,WMA4,WMT8,WMT8/A,WXE8,WXE8/A

- (1) 1

Ref. No.	Part No.	Description	Reqd. QTY			Serial No.	Parts catalogue code
			(1)	(2)	(3)		
7	28443-ZE2-W01	SPRING, RATCHET	2	-	-	-----	ESS,ESS/A,ES1,ES1/A,ES3,ES3/A,HA,HAQ,HA2,HA2/A,HEA,HEA2,HEA2/A,HEA8,HEA8/A,HH,HX,HX/A,HXQ4,HXQ4/A,HX26,HX26/A,HX8,HX8/A,LH,LH/A,LHB1,LHB3,LHB5,LHE,LHE/A,LHQ4,LJ,LJ/A,LJC,LJC/A,LJG,LJG/A,LSS,LT,LT/A,LTJ,LW,LW/A,LX,LX/A,LXE,LXE/A,LXE8,LXE8/A,LXQ4,LXQ4/A,LXU,LXU/A,LXZ,LX16,PA,PAE2,PAE2/A,PA2,PA2/A,PX,PX/A,PXE8,PXE8/A,PXU,PXU/A,PX26,PX26/A,QA,QAB1,QAB3,QAB3/A,QAQ,QAQ2,QAQ2/A,QAQ,QAQ4,QAQ4/A,QAR2,QAR2/A,QAW,QAW/A,QA2,QA2/A,QD,QD/A,QE,QE/A,QH,QH/A,QHB5,QHC,QHE,QHE4,QHE4/A,QHP1,QHP1/A,QHQ4,QHQ4/A,QHR,QHR/A,QHR4,QHR4/A,QHZ,QHZ/A,QH26,QH26/A,QL2,QME2,QME2/A,QMH,QMH/A,QP,QP/A,QSC,QSC9,QSC9/A,QSE,QSE2,QSE8,QSE8/A,QT,QT/A,QWA2,QWA4,QWA4/A,QWH2,QWH2/A,QX,QX/A,QXB,QXB/A,QXB6,QXB6/A,QXB7,QXB7/A,QXC,QXC4,QXC4/A,QXC6,QXC6/A,QXC9,QXC9/A,QXE,QXE/A,QXEB,QXE4,QXE4/A,QXE6,QXE6/A,QXE8,QXE8/A,QXQ4,QXQ4/A,QXU,QXU/A,QX26,QX26/A,RA,RA2,RA2/A,RD,RD/A,RH,RHE,RHE4,RHE4/A,RHQ4,RHQ4/A,RH26,RH26/A,RSC2,RSC2/A,RSS,RSS/A,RX,RX/A,RXQ4,RXQ4/A,RXU,RXU/A,SD,SD/A,SE,SE/A,SH,SH/A,SHE,SHE2,SHQ4,SHQ4/A,SJ,SJ/A,SJG,SJG/A,SJP,SK,SMC4,SMC4/A,SMD,SME1,SME1/A,SME6,SME6/A,SMX2,SN,SN/A,SW,SWA4,SWC4,SWC4/A,SWE,SX,SX/A,SBX,SBX/A,SBX7,SBX7/A,SXE,SXE/A,SXEB,SXEB/A,SXE4,SXE4/A,SXE8,SXE8/A, SXQ4, SXQ4/A, SXU, SXU/A, SX2, VA, VAG2, VAG2/A, VAW, VAW1, VA2, VA2/A, VDE, VDE2, VDE2/A, VD16, VEB6, VH, VKB2, VKB2/A, VKE4, VKX4, VMA4, VME2, VME2/A, VME4, VMS2, VMT, VMT/A, VMX2, VM2, VM2/A, VNG1, VNG1/A, VNT2, VNT2/A, VN17, VN17/A, VPE4, VPE4/A, VPE5, VPE7, VPE7/A, VPX4, VPX4/A, VPX5, VPX7, VPX7/A, VSD, VSD/A, VSD3, VSD3/A, VSD7, VSD7/A, VSH7, VS3, VS37, VS37/A, VWA, VWA2, VWA2/A, VWN2, VWN2/A, VWT4, VWT4/A, VW12, VW12/A, VW22, VX, VX/A, VXB, VXB/A, VXB2, VXB6, VXB7, VXB7/A, VXE, VXE8, VXE8/A, VXE4, VXE4/A, VXE6, VXE6/A, VXE7, VXE7/A, VXG, VXQ4, VXQ4/A, VXTB, VXT1, VXT1/A, VXU, VXU/A, VXU1, VXU1/A, VX26, WMA4, WMT8, WMT8/A, WXE8, WXE8/A
8	28444-ZE2-W01	RETAINER, SPRING	1	(2)	2	-----	ESS,ESS/A,ES1,ES1/A,ES3,ES3/A,HA,HAQ,HA2,HA2/A,HEA,HEA2,HEA2/A,HEA8,HEA8/A,HH,HX,HX/A,HXQ4,HXQ4/A,HX26,HX26/A,HX8,HX8/A,LH,LH/A,LHB1,LHB3,LHB5,LHE,LHE/A,LHQ4,LJ,LJ/A,LJC,LJC/A,LJG,LJG/A,LSS,LT,LT/A,LTJ,LW,LW/A,LX,LX/A,LXE,LXE/A,LXE8,LXE8/A,LXQ4,LXQ4/A,LXU,LXU/A,LXZ,LX16,PA,PAE2,PAE2/A,PA2,PA2/A,PX,PX/A,PXE8,PXE8/A,PXU,PXU/A,PX26,PX26/A,QA,QAB1,QAB3,QAB3/A,QAQ,QAQ2,QAQ2/A,QAQ,QAQ4,QAQ4/A,QAR2,QAR2/A,QAW,QAW/A,QA2,QA2/A,QD,QD/A,QE,QE/A,QH,QH/A,QHB5,QHC,QHE,QHE4,QHE4/A,QHP1,QHP1/A,QHQ4,QHQ4/A,QHR,QHR/A,QHR4,QHR4/A,QHZ,QHZ/A,QH26,QH26/A,QL2,QME2,QME2/A,QMH,QMH/A,QP,QP/A,QSC,QSC9,QSC9/A,QSE,QSE/A,QSE2,QSE8,QSE8/A,QT,QT/A,QWA2,QWA4,QWA4/A,QWH2,QWH2/A,QX,QX/A,QXB,QXB/A,QXB6,QXB6/A,QXB7,QXB7/A,QXC,QXC4,QXC4/A,QXC6,QXC6/A,QXC9,QXC9/A,QXE,QXE/A,QXEB,QXE4,QXE4/A,QXE6,QXE6/A,QXE8,QXE8/A,QXQ4,QXQ4/A,QXU,QXU/A,QX26,QX26/A,RA,RA2,RA2/A,RD,RD/A,RH,RHE,RHE4,RHE4/A,RHQ4,RHQ4/A,RH26,RH26/A,RSC2,RSC2/A,RSS,RSS/A,RX,RX/A,RXQ4,RXQ4/A,RXU,RXU/A,SD,SD/A,SE,SE/A,SH,SH/A,SHE,SHE2,SHQ4,SHQ4/A,SJ,SJ/A,SJG,SJG/A,SJP,SK,SMC4,SMC4/A,SMD,SME1,SME1/A,SME6,SME6/A,SMX2,SN,SN/A,SW,SWA4,SWC4,SWC4/A,SWE,SX,SX/A,SBX,SBX/A,SBX7,SBX7/A,SXE,SXE/A,SXEB,SXEB/A,SXE4,SXE4/A,SXE8,SXE8/A, SXQ4, SXQ4/A, SXU, SXU/A, SX2, VA, VAG2, VAG2/A, VAW, VAW1, VA2, VA2/A, VDE, VDE2, VDE2/A, VD16, VEB6, VH, VKB2, VKB2/A, VKE4, VKX4, VMA4, VME2, VME2/A, VME4, VMS2, VMT, VMT/A, VMX2, VM2, VM2/A, VNG1, VNG1/A, VNT2, VNT2/A, VN17, VN17/A, VPE4, VPE4/A, VPE5, VPE7, VPE7/A, VPX4, VPX4/A, VPX5, VPX7, VPX7/A, VSD, VSD/A, VSD3, VSD3/A, VSD7, VSD7/A, VSH7, VS3, VS37, VS37/A, VWA, VWA2, VWA2/A, VWN2, VWN2/A, VWT4, VWT4/A, VW12, VW12/A, VW22, VX, VX/A, VXB, VXB/A, VXB2, VXB6, VXB7, VXB7/A, VXE, VXE8, VXE8/A, VXE4, VXE4/A, VXE6, VXE6/A, VXE7, VXE7/A, VXG, VXQ4, VXQ4/A, VXTB, VXT1, VXT1/A, VXU, VXU/A, VXU1, VXU1/A, VX26, WMA4, WMT8, WMT8/A, WXE8, WXE8/A



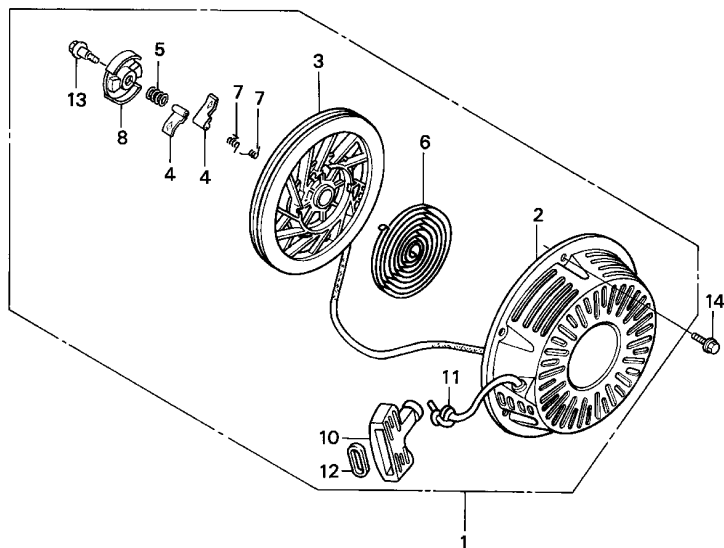

ZH90-E11008



Ref. No.	Part No.	Description	Reqd. QTY			Serial No.	Parts catalogue code
			(1)	(2)	(3)		
10	28461-ZE2-W02	GRIP, STARTER	1	-	-	-----	ESS,ESS/A,ES1,ES1/A,ES3,ES3/A,HA,HAQ,HA2,HA2/A,HEA,HEA2,HEA2/A,HEA8,HEA8/A,HH,HX,HX/A,HXQ4,HXQ4/A,HX26,HX26/A,HX8,HX8/A,LH,LH/A,LHB1,LHB3,LHB5,LHE,LHE/A,LHQ4,LJ,LJ/A,LJC,LJC/A,LJG,LJG/A,LSS,LT,LT/A,LTJ,LW,LW/A,LX,LX/A,LXE,LXE/A,LXE8,LXE8/A,LXQ4,LXQ4/A,LXU,LXU/A,LXZ,LX16,PA,PAE2,PAE2/A,PA2,PA2/A,PX,PX/A,PXE8,PXE8/A,PXU,PXU/A,PX26,PX26/A,QA,QAB1,QAB3,QAB3/A,QAE,QAE2,QAE2/A,QAE6,QAE6/A,QAG,QAG/A,QAG2,QAG2/A,QAQ,QAQ4,QAQ4/A,QAR2,QAR2/A,QAW,QAW/A,QA2,QA2/A,QD,QD/A,QE,QE/A,QH,QH/A,QHB5,QHC,QHE,QHE4,QHE4/A,QHP1,QHP1/A,QHQ4,QHQ4/A,QHR,QHR/A,QHR4,QHR4/A,QHZ,QHZ/A,QH26,QH26/A,QL2,QME2,QME2/A,QMH,QMH/A,QP,QP/A,QSC,QSC9,QSC9/A,QSE,QSE/A,QSE2,QSE8,QSE8/A,QT,QT/A,QWA2,QWA4,QWA4/A,QWH2,QWH2/A,QX,QX/A,QXB,QXB/A,QXB6,QXB6/A,QXB7,QXB7/A,QXC,QXC4,QXC4/A,QXC6,QXC6/A,QXC9,QXC9/A,QXE,QXE/A,QXEB,QXE4,QXE4/A,QXE6,QXE6/A,QXE8,QXE8/A,QXQ4,QXQ4/A,QXU,QXU/A,QX26,QX26/A,RA,RA2,RA2/A,RD,RD/A,RH,RHE,RHE4,RHE4/A,RHQ4,RHQ4/A,RH26,RH26/A,RSC2,RSC2/A,RSS,RSS/A,RX,RX/A,RXQ4,RXQ4/A,RXU,RXU/A,SD,SD/A,SE,SE/A,SH,SH/A,SHE,SHEZ,SHQ4,SHQ4/A,SJ,SJ/A,SJG,SJG/A,SJP,SK,SMC4,SMC4/A,SMD,SME1,SME1/A,SME6,SME6/A,SMX2,SN,SN/A,SW,SWA4,SWC4,SWC4/A,SWE,SX,SX/A,AXB,AXB/A,AXB7,AXB7/A,SXE,SXE/A,SXEB,SXEB/A,SXE4,SXE4/A,SXE8,SXE8/A,SXQ4,SXQ4/A,SXU,SXU/A,SX2,VA,VAG2,VAG2/A,VAW,VAW1,VA2,VA2/A,VDE,VDE2,VDE2/A,VD16,VEB6,VH,VKB2,VKB2/A,VKE4,VKX4,VMA4,VME2,VME2/A,VME4,VMS2,VMT,VMT/A,VMX2,VM2,VM2/A,VNG1,VNG1/A,VNT2,VNT2/A,VN17,VN17/A,VPE4,VPE4/A,VPE5,VPE7,VPE7/A,VPX4,VPX4/A,VPX5,VPX7,VPX7/A,VSD,VSD/A,VSD3,VSD3/A,VSD7,VSD7/A,VSH7,VS3,VS37,VS37/A,VVA,VVA2,VVA2/A,VWN2,VWN2/A,VWT4,VWT4/A,VW12,VW12/A,VW22,VX,VX/A,VXB,VXB/A,VXB2,VXB6,VXB7,VXB7/A,VXE,VXEB,VXEB/A,VXE4,VXE4/A,VXE6,VXE6/A,VXE7,VXE7/A,VXG,VXQ4,VXQ4/A,VXTB,VXT1,VXT1/A,VXU,VXU/A,VXU1,VXU1/A,VX26,WMA4,WMT8,WMT8/A,WXE8,WXE8/A

- (1) 1

Ref. No.	Part No.	Description	Reqd. QTY			Serial No.	Parts catalogue code
			(1)	(2)	(3)		
11	28462-ZE2-W01	ROPE, RECOIL STARTER	1	(1)	-	-----	HA,HAQ,HEA,HH,LHB1,LHB3,LHQ4,LXZ,PA,QA,QAB1,QAE,QAQ,QHC,QHE,QSC QXC,QXEB,Q2,RA,RHE,SHE,SHEZ,SJP,SK,SWE,SX2,VA,VAW,VAW1,VEB6,VWA VXB6,V1,W1,W1/A
			1	(1)	-	-----	1413598
	-	-	1	-----	1000085	VXP,VXQP	
	28462-ZE2-W11	1	(1)	1	-----	ESS/A,ES1/A,ES3/A,HAP,HAP/A,HA2/A,HEA2/A,HEA8/A,HX/A,HXQ4/A HX26/A,HX8/A,LH/A,LHB5,LHE/A,LJ/A,LJC/A,LJG/A,LT,LT/A,LW/A,LX/A LXE/A,LXE8/A,LXQ4/A,LXU/A,L1/A,PAE2/A,PA2/A,PX/A,PXE8,PXE8/A PXU/A,PX26/A,QAB3/A,QAE2/A,QAE6/A,QAG,QAG/A,QAG2,QAG2/A,QAQ4/A QAR2/A,QAW,QAW/A,QA2/A,QD/A,QE/A,QH/A,QHB5,QHE4/A,QHP1/A,QHQ4/A QHR,QHR/A,QHR4,QHR4/A,QHZ/A,QH26/A,QKE4,QL2,QME2/A,QMH/A,QP/A QSC9/A,QSE/A,QSE2,QSE8/A,QT/A,QWA2,QWA4,QWA4/A,QWH2,QWH2/A,QX/A QXB/A,QXB6/A,QXB7,QXB7/A,QXC4/A,QXC6/A,QXC9/A,QXE/A,QXE4/A,QXE6/A QXE8/A,QXQ4/A,QXU/A,QX26/A,Q1/A,RA2/A,RD/A,RHE4/A,RHQ4/A,RH26/A RSC2/A,RSS,RSS/A,RX/A,RXP,RXP/A,RXQ4/A,RXU/A,R1/A,SD/A,SE/A,SH/A SHQ4/A,SJ/A,SJG/A,SMC4/A,SME1/A,SME6/A,SMX2,SN/A,SWA4,SWC4/A,SX/A SXB/A,SXB7,SXB7/A,SXE/A,SXEB/A,SXE4/A,SXE8/A,SXQ4/A,SXU/A,S1/A VAG2,VAG2/A,VA2/A,VDE2/A,VKB2/A,VKE4,VKX4,VMA4,VME2/A,VME4,VMS2 VMT,VMT/A,VMX2,VM2/A,VNG1/A,VNT2/A,VN17,VN17/A,VPE4/A,VPE5,VPE7 VPE7/A,VPX4/A,VPX5,VPX7,VPX7/A,VSD/A,VSD3/A,VSD7,VSD7/A,VSH7,VS3 VS37,VS37/A,VWA2/A,VWN2/A,VWT4/A,VW12/A,VX/A,VXB/A,VXB7,VXB7/A VXEB/A,VXE4/A,VXE6/A,VXE7,VXE7/A,VXP/A,VXQ4/A,VXT1/A,VXU/A,VXU1/A WMA4,WMT8/A,WXE8,WXE8/A
			1	(1)	-	1413599	ESS,ES1,ES3,HA2,HEA2,HEA8,HX,HXQ4,HX26,HX8,LH,LHE,LJ,LJC,LJG,LSS LTJ,LW,LX,LXE,LXE8,LXQ4,LXU,LX16,L1,PAE2,PA2,PX,PXU,PX26,QAB3 QAE2,QAE6,QAQ4,QAR2,QA2,QD,QE,QH,QHE4,QHP1,QHQ4,QHZ,QH26,QME2,QMH QP,QSC9,QSE,QSE8,QT,QX,QXB,QXB6,QXC4,QXC6,QXC9,QXE,QXE4,QXE6,QXE8 QXQ4,QXU,QX26,Q1,RA2,RD,RH,RHE4,RHQ4,RH26,RSC2,RX,RXQ4,RXU,R1,SD SE,SH,SHQ4,SJ,SJG,SMC4,SMD,SME1,SME6,SN,SW,SWC4,SX,SBX,SXE,SXEB SXE4,SXE8,SXQ4,SXU,S1,VA2,VDE,VDE2,VD16,VH,VKB2,VME2,VM2,VNG1 VNT2,VPE4,VPX4,VSD,VSD3,VWA2,VWN2,VWT4,VW12,VW22,VX,VXB,VXB2,VXE VXEB,VXE4,VXE6,VXG,VXQ4,VXTB,VXT1,VXU,VXU1,VX26,WMT8
			-	-	1	1000086	VXP,VXQP
12	28469-ZE2-W01	GRIP, REINFORCEMENT	1	(1)	-	-----	HA,HAQ,HEA,HH,LHB1,LHB3,LHQ4,LXZ,PA,QA,QAB1,QAE,QAQ,QHC,QHE,QSC QXC,QXEB,Q2,RA,RHE,SHE,SHEZ,SJP,SK,SWE,SX2,VA,VAW,VAW1,VEB6,VWA VXB6,V1,W1,W1/A
			1	(1)	-	-----	1413598
	-	-	1	-----	1000079	VXP,VXQP	



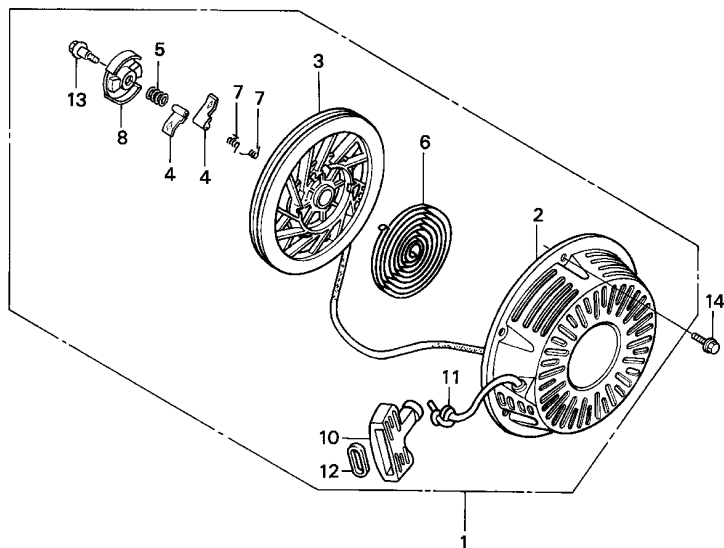

ZH90-E11008



Ref. No.	Part No.	Description	Reqd. QTY			Serial No.	Parts catalogue code
			(1)	(2)	(3)		
13	90004-ZE2-W01	SCREW, CENTER	1	-	-		ESS,ESS/A,ES1,ES1/A,ES3,ES3/A,HA,HAQ,HA2,HA2/A,HEA,HEA2,HEA2/A,HEA8,HEA8/A,HH,HX,HX/A,HXQ4,HXQ4/A,HX26,HX26/A,HX8,HX8/A,LH,LH/A,LHB1,LHB3,LHB5,LHE,LHE/A,LHQ4,LJ,LJ/A,LJC,LJC/A,LJG,LJG/A,LSS,LT,LT/A,LTJ,LW,LW/A,LX,LX/A,LXE,LXE/A,LXE8,LXE8/A,LXQ4,LXQ4/A,LXU,LXU/A,LXZ,LX16,PA,PAE2,PAE2/A,PA2,PA2/A,PX,PX/A,PXE8,PXE8/A,PXU,PXU/A,PX26,PX26/A,QA,QAB1,QAB3,QAB3/A,QAE,QAE2,QAE2/A,QAE6,QAE6/A,QAG,QAG/A,QAG2,QAG2/A,QAQ,QAQ4,QAQ4/A,QAR2,QAR2/A,QAW,QAW/A,QA2,QA2/A,QD,QD/A,QE,QE/A,QH,QH/A,QHB5,QHC,QHE,QHE4,QHE4/A,QHP1,QHP1/A,QHQ4,QHQ4/A,QHR,QHR/A,QHR4,QHR4/A,QHZ,QHZ/A,QH26,QH26/A,QL2,QME2,QME2/A,QMH,QMH/A,QP,QP/A,QSC,QSC9,QSC9/A,QSE,QSE/A,QSE2,QSE8,QSE8/A,QT,QT/A,QWA2,QWA4,QWA4/A,QWH2,QWH2/A,QX,QX/A,QXB,QXB/A,QXB6,QXB6/A,QXB7,QXB7/A,QXC,QXC4,QXC4/A,QXC6,QXC6/A,QXC9,QXC9/A,QXE,QXE/A,QXEB,QXE4,QXE4/A,QXE6,QXE6/A,QXE8,QXE8/A,QXQ4,QXQ4/A,QXU,QXU/A,QX26,QX26/A,RA,RA2,RA2/A,RD,RD/A,RH,RHE,RHE4,RHE4/A,RHQ4,RHQ4/A,RH26,RH26/A,RSC2,RSC2/A,RSS,RSS/A,RX,RX/A,RXQ4,RXQ4/A,RXU,RXU/A,SD,SD/A,SE,SE/A,SH,SH/A,SHE,SHE2,SHQ4,SHQ4/A,SJ,SJ/A,SJG,SJG/A,SJP,SK,SMC4,SMC4/A,SMD,SME1,SME1/A,SME6,SME6/A,SMX2,SN,SN/A,SW,SWA4,SWC4,SWC4/A,SWE,SX,SX/A, SXB,SXB/A, SXB7,SXB7/A, SXE,SXE/A, SXEB,SXEB/A, SXE4,SXE4/A, SXE8,SXE8/A, SXQ4,SXQ4/A, SXU,SXU/A, SX2,VA,VAG2,VAG2/A,VAW,VAW1,VA2,VA2/A,VDE,VDE2,VDE2/A,VD16,VEB6,VH,VKB2,VKB2/A,VKE4,VKX4,VMA4,VME2,VME2/A,VME4,VMS2,VMT,VMT/A,VMX2,VM2,VM2/A,VNG1,VNG1/A,VNT2,VNT2/A,VN17,VN17/A,VPE4,VPE4/A,VPE5,VPE7,VPE7/A,VPX4,VPX4/A,VPX5,VPX7,VPX7/A,VSD,VSD/A,VSD3,VSD3/A,VSD7,VSD7/A,VSH7,VS3,VS37,VS37/A,VVA,VVA2,VVA2/A,VWN2,VWN2/A,VWT4,VWT4/A,VW12,VW12/A,VW22,VX,VX/A,VXB,VXB/A,VXB2,VXB6,VXB7,VXB7/A,VXE,VXEB,VXEB/A,VXE4,VXE4/A,VXE6,VXE6/A,VXE7,VXE7/A,VXG,VXQ4,VXQ4/A,VXTB,VXT1,VXT1/A,VXU,VXU/A,VXU1,VXU1/A,VX26,WMA4,WMT8,WMT8/A,WXE8,WXE8/A

- (1) 1

Ref. No.	Part No.	Description	Reqd. QTY			Serial No.	Parts catalogue code
			(1)	(2)	(3)		
14	95701-06008-00	BOLT, FLANGE, 6X8	3	(3)	-	-----	ES3,ES3/A,HA,HAQ,HEA,HH,LHB1,LHB3,LHE,LHQ4,LSS,LTJ,LXZ,LX16,L1 L1/A,PA,QA,QAB1,QAE,QAQ,QH,QHC,QHE,QSC,QXC,QXEB,Q1,Q1/A,Q2,RA,RH RHE,R1,R1/A,SHE,SHEZ,SJ,SJP,SK,SMD,SW,SWE,SX2,VA,VAW,VAW1,VDE VD16,VEB6,VH,VWA,VW22,VXB2,VXB6,VXE,VXG,VX26,W1,W1/A
	90008-ZE2-003	BOLT, FLANGE, 6X10	3	(3)	-	-----	ESS,ESS/A,ES1,ES1/A,HA2,HA2/A,HEA2,HEA2/A,HEA8,HEA8/A,HX,HX/A HXQ4,HXQ4/A,HX26,HX26/A,HX8,HX8/A,LH,LH/A,LHB5,LHE/A,LJ,LJ/A,LJC LJC/A,LJG,LJG/A,LT,LT/A,LW,LW/A,LX,LX/A,LXE,LXE/A,LXE8,LXE8/A LXQ4,LXQ4/A,LXU,LXU/A,L1,L1/A,PAE2,PAE2/A,PA2,PA2/A,PX,PX/A,PXE8 PXE8/A,PXU,PXU/A,PX26,PX26/A,QAB3,QAB3/A,QAE2,QAE2/A,QAE6,QAE6/A QAG,QAG/A,QAG2,QAG2/A,QAQ4,QAQ4/A,QAR2,QAR2/A,QAW,QAW/A,QA2,QA2/A QD,QD/A,QE,QE/A,QH/A,QHB5,QHE4,QHE4/A,QHP1,QHP1/A,QHQ4,QHQ4/A,QHR QHR/A,QHR4,QHR4/A,QHZ,QHZ/A,QH26,QH26/A,QKE4,QL2,QME2,QME2/A,QMH QMH/A,QP,QP/A,QSC9,QSC9/A,QSE,QSE/A,QSE2,QSE8,QSE8/A,QT,QT/A,QWA2 QWA4,QWA4/A,QWH2,QWH2/A,QX,QX/A,QXB,QXB/A,QXB6,QXB6/A,QXB7,QXB7/A QXC4,QXC4/A,QXC6,QXC6/A,QXC9,QXC9/A,QXE,QXE/A,QXE4,QXE4/A,QXE6 QXE6/A,QXE8,QXE8/A,QXQ4,QXQ4/A,QXU,QXU/A,QX26,QX26/A,Q1,Q1/A,RA2 RA2/A,RD,RD/A,RHE4,RHE4/A,RHQ4,RHQ4/A,RH26,RH26/A,RSC2,RSC2/A,RSS RSS/A,RX,RX/A,RXQ4,RXQ4/A,RXU,RXU/A,R1,R1/A,SD,SD/A,SE,SE/A,SH SH/A,SHQ4,SHQ4/A,SJ/A,SJG,SJG/A,SKE1,SMC4,SMC4/A,SME1,SME1/A,SME6 SME6/A,SMX2,SN,SN/A,SWA4,SWC4,SWC4/A,SX,SX/A,SBX,SBX/A,SBX7 SBX7/A,SXE,SXE/A,SXEB,SXEB/A,SXE4,SXE4/A,SXE8,SXE8/A,SXQ4,SXQ4/A SXU,SXU/A,S1,S1/A,VAG2,VAG2/A,VA2,VA2/A,VDE2,VDE2/A,VKB2,VKB2/A VKE4,VKX4,VMA4,VME2,VME2/A,VME4,VMS2,VMT,VMT/A,VMX2,VM2,VM2/A VNG1,VNG1/A,VNT2,VNT2/A,VN17,VN17/A,VPE4,VPE4/A,VPE5,VPE7,VPE7/A VPX4,VPX4/A,VPX5,VPX7,VPX7/A,VSD,VSD/A,VSD3,VSD3/A,VSD7,VSD7/A VSH7,VS3,VS37,VS37/A,VWA2,VWA2/A,VWN2,VWN2/A,VWT4,VWT4/A,VW12 VW12/A,VX,VX/A,VXB,VXB/A,VXB7,VXB7/A,VXEB,VXEB/A,VXE4,VXE4/A,VXE6 VXE6/A,VXE7,VXE7/A,VXQ4,VXQ4/A,VXTB,VXT1,VXT1/A,VXU,VXU/A,VXU1 VXU1/A,WMA4,WMT8,WMT8/A,WXE8,WXE8/A,W1,W1/A
			-	-	3		



E-12

FAN COVER

11

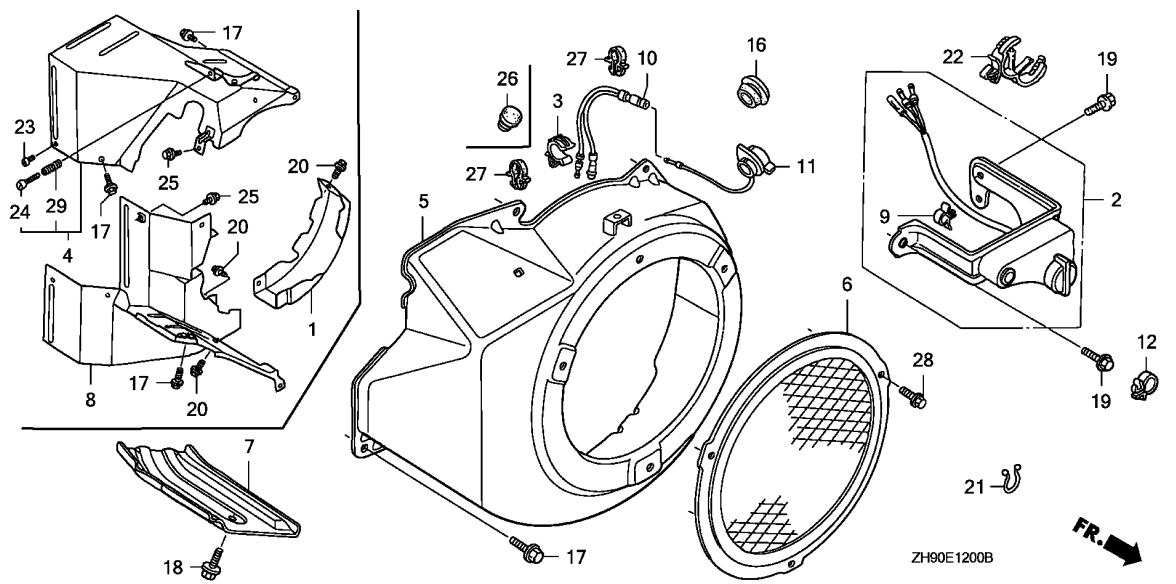

Ref. No.	L.O.N.	(Relative ref. Number) Description	F.R.T.
2	6151C6	SWITCH, OIL ALERT UNIT	0.1
4	4141E2	SHROUD, ENGINE :UPPER	0.3
5	1141G8	COVER, ENGINE COOLING FAN	0.2
6	4141C9	PROTECTOR, FAN COVER	0.1
7	4141E3	SHROUD, ENGINE	0.3
8	4141E0	SHROUD, ENGINE :LOWER	0.3
10	6111A3	CORD, ENGINE STOP SWITCH	0.1
11	6151D9	SWITCH, ENGINE STOP	0.1

2

Ref. No.	Part No.	Description	Reqd. QTY			Serial No.	Parts catalogue code
			(1)	(2)	(3)		
1	11315-ZB7-000	SCROLL, GENERATOR FAN	1	-	-	-----	ESS,ESS/A
2	15520-ZE2-003	ALERT UNIT, OIL	1	(1)	-	-----	1033679 HA,HX,LX,LXZ,L1,PA,PX,QA,QX,QXB,QXC,Q1,RA,RX,R1,SJP,SX,SXB,S1,VA VAW,VNG1,VSD,VX,VXB,V1,W1
	36100-ZH9-V01	SWITCH ASSY., ENGINE STOP (SDMO)	1	-	-	1056015 1225610	VSD3
	36100-ZH9-V02	1	-	-	-----	VSD3/A,VS37,VS37/A
			1	-	-	1225611	VSD3

Ref. No.	Part No.	Description	Reqd. QTY			Serial No.	Parts catalogue code
			(1)	(2)	(3)		
3	16731-ZE2-003	CLIP, TUBE	1	-	-	-----	ES1,ES1/A,HA,HAQ,HA2,HA2/A,HEA,HEA2,HEA2/A,HEA8,HEA8/A,HH,HX,HX/A HXQ4,HXQ4/A,HX26,HX26/A,HX8,HX8/A,LH,LH/A,LHB1,LHB3,LHB5,LHE LHE/A,LHQ4,LJ,LJ/A,LJC,LJC/A,LJG,LJG/A,LSS,LT,LT/A,LTJ,LW,LW/A LWD1,LWD1/A,LX,LX/A,LXE,LXE/A,LXE8,LXE8/A,LXQ4,LXQ4/A,LXU,LXU/A LXZ,LX16,PA,PAE2,PAE2/A,PA2,PA2/A,PX,PX/A,PXE8,PXE8/A,PXU,PXU/A PX26,PX26/A,QA,QAB1,QAB3,QAB3/A,QAE,QAE2,QAE2/A,QAE6,QAE6/A,QAG QAG/A,QAG2,QAG2/A,QAQ,QAQ4,QAQ4/A,QAR2,QAR2/A,QAW,QAW/A,QA2,QA2/A QD,QD/A,QE,QE/A,QH,QH/A,QHB5,QHC,QHE,QHE4,QHE4/A,QHP1,QHP1/A,QHQ4 QHQ4/A,QHR,QHR/A,QHR4,QHR4/A,QHZ,QHZ/A,QH26,QH26/A,QKE3,QKE3/A QKE4,QL2,QME2,QME2/A,QMH,QMH/A,QP,QP/A,QSC,QSC9,QSC9/A,QSE,QSE/A QSE2,QSE8,QSE8/A,QT,QT/A,QWA2,QWA4,QWA4/A,QWH2,QWH2/A,QX,QX/A,QXB QXB/A,QXB6,QXB6/A,QXB7,QXB7/A,QXC,QXC4,QXC4/A,QXC6,QXC6/A,QXC9 QXC9/A,QXE,QXE/A,QXEB,QXE4,QXE4/A,QXE6,QXE6/A,QXE8,QXE8/A,QXQ4 QXQ4/A,QXU,QXU/A,QX26,QX26/A,RA,RA2,RA2/A,RD,RD/A,RH,RHE,RHE4 RHE4/A,RHQ4,RHQ4/A,RH26,RH26/A,RSS,RSS/A,RX,RX/A,RXQ4,RXQ4/A,RXU RXU/A,SD,SD/A,SE,SE/A,SH,SH/A,SHE,SHE2,SHQ4,SHQ4/A,SJ,SJ/A,SJG SJG/A,SJP,SK,SKE1,SMC4,SMC4/A,SMD,SME1,SME1/A,SME6,SME6/A,SMX2,SN SN/A,SW,SWA4,SWC4,SWC4/A,SWE,SX,SX/A,SXB,SXB/A,SXB7,SXB7/A,SXE SXE/A,SXEB,SXEB/A,SXE4,SXE4/A,SXE8,SXE8/A,SXQ4,SXQ4/A,SXU,SXU/A SX2,VA,VAG2,VAG2/A,VAW,VAW1,VA2,VA2/A,VDE,VDE2,VDE2/A,VD16,VEB6 VH,VKB2,VKB2/A,VKE4,VKX4,VMA4,VME2,VME2/A,VME4,VMS2,VMX2,VM2 VM2/A,VNG1,VNG1/A,VNT2,VNT2/A,VN17,VN17/A,VPE4,VPE4/A,VPE5,VPE7 VPE7/A,VPX4,VPX4/A,VPX5,VPX7,VPX7/A,VSD,VSD/A,VSD3,VSD3/A,VSD7 VSD7/A,VSH7,VS37,VS37/A,VWA,VWA2,VWA2/A,VWN2,VWN2/A,VWT4,VWT4/A VW12,VW12/A,VW22,VX,VX/A,VXB,VXB/A,VXB2,VXB6,VXB7,VXB7/A,VXE,VXEB VXEB/A,VXE4,VXE4/A,VXE6,VXE6/A,VXE7,VXE7/A,VXG,VXQ4,VXQ4/A,VXTB VXT1,VXT1/A,VXU,VXU/A,VXU1,VXU1/A,VX26,WMA4,WMT8,WMT8/A,WXE8 WXE8/A
			-	1	-	-----	
4	19602-ZE2-E10	SHROUD ASSY., UPPER	1	-	-	-----	ESS,ESS/A
5	19610-ZE2-W00ZB	COVER COMP., FAN					
		R8.....BRIGHT RED	1	-	-	-----	1061099 HAQ,QAQ
	19610-ZE2-W00ZC	*NH1*.....BLACK	1	-	-	-----	1061099 HAQ,QAQ



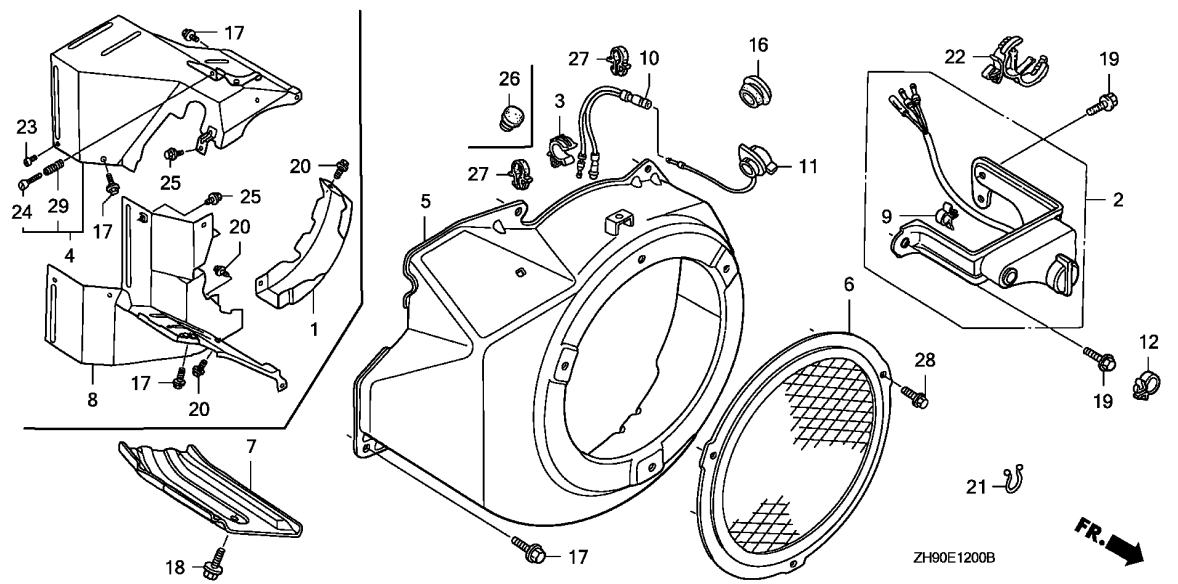

Ref. No.	Part No.	Description	Reqd. QTY	Serial No.	Parts catalogue code
(5)	19610-ZE2-010ZA	COVER COMP., FAN	1		
	R8BRIGHT RED	(1)	(2)	(3)
			1	-----	-----
					ES1,HA,HAP,HA2,HEA,HEA2,HEA8,HH,HX,HXQ4,HX26,HX8,LH,LHB1,LHB3,LHB5,LHE,LHQ4,LJ,LJC,LJG,LSS,LT,LTJ,LW,LWD,LWD1,LX,LXE,LXE8,LXQ4,LXU,LXZ,LX16,L1,PA,PAE2,PA2,PX,PXE8,PXU,PX26,QA,QAB1,QAB3,QAQAE2,QAQAE6,QAQ,QAQ2,QAQ4,QAQ2,QAQ,QA2,QD,QE,QH,QHB5,QHC,QHE,QHE4,QHP1,QHQ4,QHR,QHR4,QHZ,QH26,QKE3,QKE4,QME2,QMH,QP,QSC,QSC9,QSE,QSE8,QT,QWA4,QX,QXB,QXB6,QXB7,QXB7/A,QXC,QXC4,QXC6,QXC9,QXE,QXEB,QXE4,QXE6,QXE8,QXQ4,QXU,QX26,Q1,Q2,RA,RA2,RD,RH,RHE,RHE4,RHQ4,RH26,RSC2,RSS,RX,RXP,RXQ4,RXU,R1,SD,SE,SH,SHE,SHEZ,SHQ4,SJ,SJG,SJP,SK,SKE1,SMC4,SMD,SME1,SME6,SN,SW,SWC4,SWE,SX,SXB,SXB7,SXB7/A,SXE,SXEB,SXE4,SXE8,SXQ4,SXU,SX2,S1,VA,VAW,VA2,VDE,VDE2,VD16,VEB6,VH,VKB2,VME2,VM2,VNG1,VNG1/A,VNT2,VPE4,VPE7,VPX4,VPX7,VPX7/A,VSD,VSD3,VSD7,VSD7/A,VS37,VS37/A,VVA,VVN2,VWT4,VW12,VX,VXB,VXB2,VXB6,VXB7,VXB7/A,VXE,VXEB,VXE4,VXE6,VXE7,VXE7/A,VXG,VXP,VXQP,VXQ4,VXTB,VXT1,VXU,VXU1,VX26,V1,WMT8,WXE8,W1

Ref. No.	Part No.	Description	Reqd. QTY			Serial No.	Parts catalogue code
			(1)	(2)	(3)		
(5)	19610-ZE2-010ZA	COVER COMP., FAN *R8*.....BRIGHT RED	1	-	1	2080023	ES1/A, HAP/A, HA2/A, HEA2/A, HEA8/A, HX/A, HXQ4/A, HX26/A, HX8/A, LH/A, LHE/A, LJ/A, LJC/A, LJG/A, LT/A, LW/A, LWD1/A, LX/A, LXE/A, LXQ4/A, LXU/A, PAE2/A, PA2/A, PX/A, PXE8/A, PXU/A, PX26/A, QAB3/A, QAE2/A, QAE6/A, QAG/A, QAG2/A, QAQ4/A, QAR2/A, QAW/A, QA2/A, QD/A, QE/A, QH/A, QHE4/A, QHP1/A, QHQ4/A, QHR/A, QHR4/A, QHZ/A, QH26/A, QKE3/A, QME2/A, QMH/A, QP/A, QSC9/A, QSE/A, QSE2, QSE8/A, QT/A, QWA4/A, QX/A, QXB/A, QXB6/A, QXC4/A, QXC6/A, QXC9/A, QXE/A, QXE4/A, QXE6/A, QXE8/A, QXQ4/A, QXU/A, QX26/A, RA2/A, RD/A, RHE4/A, RHQ4/A, RH26/A, RSC2/A, RSS/A, RX/A, RXQ4/A, RXU/A, SD/A, SE/A, SH/A, SHQ4/A, SJ/A, SJG/A, SMC4/A, SME1/A, SME6/A, SN/A, SWC4/A, SX/A, SXB/A, SXE/A, SXEB/A, SXE4/A, SXE8/A, SXQ4/A, SXU/A, VAG2, VAG2/A, VA2/A, VDE2/A, VKB2/A, VME2/A, VM2/A, VNT2/A, VPE4/A, VPE7/A, VPX4/A, VSD/A, VSD3/A, VWN2/A, VWT4/A, VX/A, VXB/A, VXE8/A, VXE4/A, VXE6/A, VXQ4/A, VXT1/A, VXU/A, VXU1/A, WMT8/A, WXE8/A
			1	-	-	1061100	HAQ, QAQ
			1	-	-	2080024	VW12/A
			-	(1)	-	2085591	L1/A, Q1/A, R1/A, S1/A, W1/A
			-	-	1	1100008	RXP/A, VXP/A
	19610-ZE2-010ZC	*NH1*.....BLACK	1	-	-		HA, HA2, HA2/A, PA2, PA2/A, QA, QAE2, QAE2/A, QAQ4, QAQ4/A, QAR2, QAR2/A, QA2, QA2/A, QL2, QWA2, QWA4, QWA4/A, QWH2, QWH2/A, QXC9, QXC9/A, RA2, RA2/A, SMX2, SWC4, SWC4/A, VA2, VA2/A, VKE4, VKX4, VMA4, VME2, VME4, VM2, VM2/A, VN17, VN17/A, VXE7, VXE7/A
			1	-	-	1061100	HAQ, QAQ
	19610-ZE2-010ZD	*T41*...BARTELL BLUE METALLIC	1	-	-		QA, QAQ4, QAQ4/A, QA2, QA2/A, QX26, QX26/A
	19610-ZE2-010ZF	*NH246*.....LOOSEY GRAY	1	-	-		HAQ, QAQ
	19610-ZE2-010ZG	*NH105*...MAT BLACK (#15-#20)	1	-	-		VA, VAW1, VME2, VME2/A, VMS2, VMX2, VM2, VM2/A, VWA2, VWA2/A, VW12, VW12/A, VW22
	19610-ZE2-010ZJ	*T77*.....SEC WINE RED	1	-	-		ES1, ES1/A
	19610-ZE2-700ZA	*R8*.....BRIGHT RED	1	-	-		VMT
			1	-	-	2105530	VMT/A
	19610-ZH9-D40ZA	*R8*.....BRIGHT RED	1	-	-		ES3
			1	-	-	2088446	ES3/A
	19610-ZH9-D40ZB	*T77*.....SEC WINE RED	1	-	-		ES3, ES3/A
	19610-ZH9-V10	COVER COMP., FAN (SHIBAURA)	1	-	-		ESS, ESS/A
	19610-ZE2-010ZL	COVER COMP., FAN *R280*.....POWER RED	1	-	1	2080024	ES1/A, HAP/A, HA2/A, HEA2/A, HEA8/A, HX/A, HXQ4/A, HX26/A, HX8/A, LH/A, LHB5, LHE/A, LJ/A, LJC/A, LJG/A, LT/A, LW/A, LWD1/A, LX/A, LXE/A, LXE8/A, LXQ4/A, LXU/A, PAE2/A, PA2/A, PX/A, PXE8/A, PXU/A, PX26/A, QAB3/A, QAE2/A, QAE6/A, QAG/A, QAG2/A, QAQ4/A, QAR2/A, QAW/A, QA2/A, QD/A, QE/A, QH/A, QHB5, QHE4/A, QHP1/A, QHQ4/A, QHR/A, QHR4/A, QHZ/A, QH26/A, QKE3/A, QKE4, QME2/A, QMH/A, QP/A, QSC9/A, QSE/A, QSE2, QSE8/A, QT/A, QWA4/A, QX/A, QXB/A, QXB6/A, QXB7, QXB7/A, QXC4/A, QXC6/A, QXC9/A, QXE/A, QXE4/A, QXE6/A, QXE8/A, QXQ4/A, QXU/A, QX26/A, RA2/A, RD/A, RHE4/A, RHQ4/A, RH26/A, RSC2/A, RSS/A, RX/A, RXQ4/A, RXU/A, SD/A, SE/A, SH/A, SHQ4/A, SJ/A, SJG/A, SMC4/A, SME1/A, SME6/A, SN/A, SWC4/A, SX/A, SXB/A, SXB7, SXB7/A, SXE/A, SXEB/A, SXE4/A, SXE8/A, SXQ4/A, SXU/A, VAG2/A, VA2/A, VDE2/A, VKB2/A, VME2/A, VM2/A, VNT2/A, VPE4/A, VPE7/A, VPX4/A, VPX7, VPX7/A, VSD/A, VSD3/A, VSD7, VSD7/A, VS37, VS37/A, VWN2/A, VWT4/A, VW12/A, VX/A, VXB/A, VXB7, VXB7/A, VXE8/A, VXE4/A, VXE6/A, VXE7, VXE7/A, VXQ4/A, VXT1/A, VXU/A, VXU1/A, WMT8/A, WXE8/A
			1	-	-		SWA4, VPE5, VPX5, VSH7, VWA2/A, WMA4
			-	(1)	-	2085592	L1/A, Q1/A, R1/A, S1/A, W1/A
			-	-	1	1100009	RXP/A, VXP/A
	19610-ZE2-700ZL	*R280*.....POWER RED	1	-	-	2105531	VMT/A
	19610-ZH9-D40ZC	*R280*.....POWER RED	1	-	-		VS3
			1	-	-	2088447	ES3/A
	19610-ZH9-D40ZD	*NH105*...MAT BLACK (#15-#20)	1	-	-		VS3



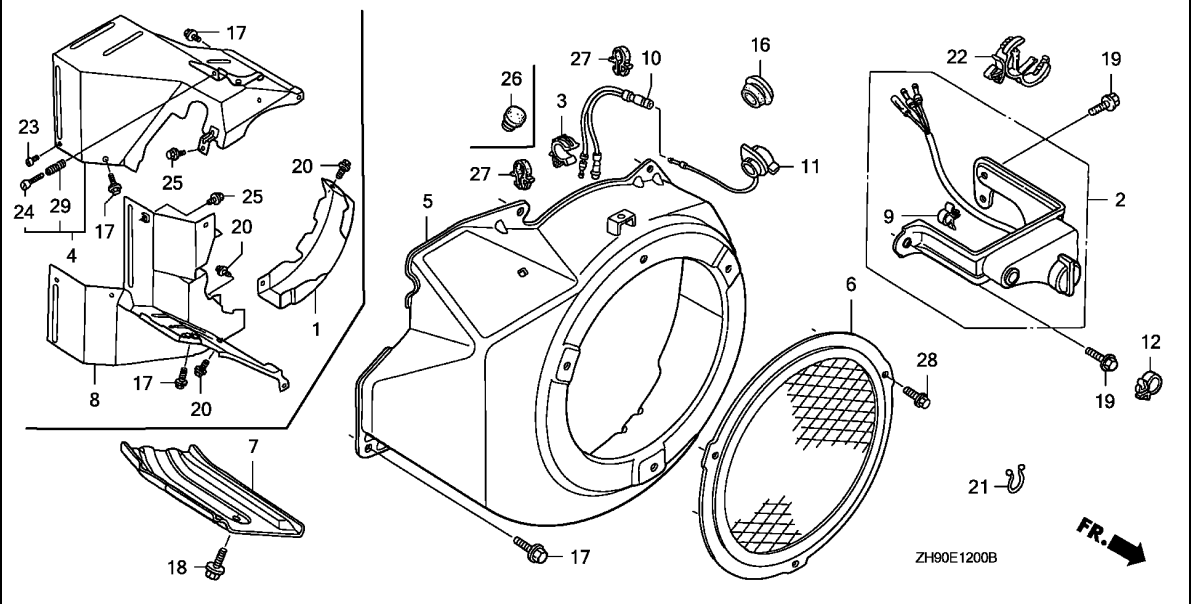

Ref. No.	Part No.	Description	Reqd. QTY			Serial No.	Parts catalogue code
			(1)	(2)	(3)		

6	19620-ZE2-000ZA	PROTECTOR COMP., FAN COVER					
		R8.....BRIGHT RED	1	-	-	-----	LWD,LWD1,QKE3,SKE1
	19620-ZE2-000ZD	*R280*.....POWER RED	1	-	-	-----	LWD1/A,QKE3/A

Ref. No.	Part No.	Description	Reqd. QTY			Serial No.	Parts catalogue code
			(1)	(2)	(3)		
7	19631-ZE2-D00	SHROUD	1	-	-		ES1, ES1/A, ES3, ES3/A, HA, HAQ, HA2, HA2/A, HEA, HEA2, HEA2/A, HEA8, HEA8/A, HH, HX, HX/A, HXQ4, HXQ4/A, HX26, HX26/A, HX8, HX8/A, LH, LH/A, LHB1, LHB3, LHB5, LHE, LHE/A, LHQ4, LJ, LJ/A, LJC, LJC/A, LJG, LJG/A, LSS, LT, LT/A, LTJ, LW, LW/A, LWD, LWD1, LWD1/A, LX, LX/A, LXE, LXE/A, LXE8, LXE8/A, LXQ4, LXQ4/A, LXU, LXU/A, LXZ, LXZ, LX16, PA, PAE2, PAE2/A, PA2, PA2/A, PX, PX/A, PXE8, PXE8/A, PXU, PXU/A, PX26, PX26/A, QA, QAB1, QAB3, QAB3/A, QAE, QAE2, QAE2/A, QAE6, QAE6/A, QAG, QAG/A, QAG2, QAG2/A, QAQ, QAQ4, QAQ4/A, QAR2, QAR2/A, QAW, QAW/A, QA2, QA2/A, QD, QD/A, QE, QE/A, QH, QH/A, QHB5, QHC, QHE, QHE4, QHE4/A, QHP1, QHP1/A, QHQ4, QHQ4/A, QHR, QHR/A, QHR4, QHR4/A, QHZ, QHZ/A, QH26, QH26/A, QKE3, QKE3/A, QKE4, QL2, QME2, QME2/A, QMH, QMH/A, QP, QP/A, QSC, QSC9, QSC9/A, QSE, QSE/A, QSE2, QSE8, QSE8/A, QT, QT/A, QWA2, QWA4, QWA4/A, QWH2, QWH2/A, QX, QX/A, QXB, QXB/A, QXB6, QXB6/A, QXB7, QXB7/A, QXC, QXC4, QXC4/A, QXC6, QXC6/A, QXC9, QXC9/A, QXE, QXE/A, QXB, QXB/A, QXE4, QXE4/A, QXE6, QXE6/A, QXE8, QXE8/A, QXQ4, QXQ4/A, QXU, QXU/A, QX26, QX26/A, RA, RA2, RA2/A, RD, RD/A, RH, RHE, RHE4, RHE4/A, RHQ4, RHQ4/A, RH26, RH26/A, RSC2, RSC2/A, RSS, RSS/A, RX, RX/A, RXQ4, RXQ4/A, RXU, RXU/A, SD, SD/A, SE, SE/A, SH, SH/A, SHE, SHEZ, SHQ4, SHQ4/A, SJ, SJ/A, SJG, SJG/A, SJP, SK, SKE1, SMC4, SMC4/A, SMD, SME1, SME1/A, SME6, SME6/A, SMX2, SN, SN/A, SW, SWA4, SWC4, SWC4/A, SWE, SX, SX/A, SXB, SXB/A, SXB7, SXB7/A, SXE, SXE/A, SXEB, SXEB/A, SXE4, SXE4/A, SXE8, SXE8/A, SXQ4, SXQ4/A, SXU, SXU/A, SX2, VA, VAG2, VAG2/A, VAW, VAW1, VA2, VA2/A, VDE, VDE2, VDE2/A, VD16, VEB6, VH, VKB2, VKB2/A, VKE4, VKX4, VMA4, VME2, VME2/A, VME4, VMS2, VMT, VMT/A, VMX2, VM2, VM2/A, VV1, VV1/A, VNT2, VNT2/A, VN17, VN17/A, VPE4, VPE4/A, VPE5, VPE7, VPE7/A, VPX4, VPX4/A, VPX5, VPX7, VPX7/A, VSD, VSD/A, VSD3, VSD3/A, VSD7, VSD7/A, VSH7, VS37, VS37/A, VWA, VWA2, VWA2/A, VWN2, VWN2/A, VWT4, VWT4/A, VW12, VW12/A, VW22, VX, VX/A, VXB, VXB/A, VXB2, VXB6, VXB7, VXB7/A, VXE, VXE, VXE/A, VXE4, VXE4/A, VXE6, VXE6/A, VXE7, VXE7/A, VXG, VXQ4, VXQ4/A, VXTB, VXT1, VXT1/A, VXU, VXU/A, VXU1, VXU1/A, VX26, WMA4, WMT8, WMT8/A, WX8, WX8/A
8	19640-ZE2-E10	SHROUD COMP., LOWER	1	-	-		ESS, ESS/A
9	30701-883-000	CLIP, HIGH TENSION CORD (8MM)	1	(1)	-	1033679	HA, HX, LX, LXZ, L1, PA, PX, QA, QX, QXB, QXC, Q1, RA, RX, R1, SJP, SX, SXB, S1, VAW, VNG1, VSD, VX, VXB, V1, W1
10	32197-ZH8-003	SUB HARNESS	1	1	-	1033680	1225386 HA, HX, LX, LXZ, L1, PA, PX, QA, QX, QXB, QXC, Q1, RA, RX, R1, SX, SXB, S1, VAW, VNG1, VSD, VX, VXB, V1, W1
			1	(1)	1	1225386	1225386 HAQ, HA2, HXQ4, HX26, LXQ4, LX16, PA2, PX26, QAB1, QAB3, QAQ, QAQ4, QAR2, QA2, QXC4, QXC6, QXC9, QXQ4, QX26, Q2, RA2, RSC2, RXQ4, SMC4, SMD, SME6, SWC4, SXQ4, SX2, VAW1, VA2, VD16, VSD3, VWA2, VWN2, VW12, VW22, VXB2, VXB6, VXG, VXP, VXQ4, VXU, VX26
			1	-	-		VME4, VWA, VWA2/A
			1	-	-	1033680	SJP
11	36100-ZE1-015	SWITCH ASSY., ENGINE STOP ...	1	(1)	-	1225386	1225386 HAQ, HA2, HX26, LX16, L1, PA2, PX26, QAB1, QAB3, QAQ, QAR2, QA2, QXC6, QXC9, QX26, Q1, Q2, RA2, RSC2, R1, SMD, SX2, S1, VAW1, VA2, VWN2, VW12, VW22, VXB2, VXB6, VXU, VX26, V1, W1
			1	-	-		HH, LH, LH/A, LHB1, LHB3, LHB5, LJ, LJ/A, LJG, LJG/A, LSS, LT, LT/A, LW, LW/A, QD, QD/A, QH, QH/A, QHB5, QHC, QHP1, QHP1/A, QHZ, QHZ/A, QH26, QH26/A, QMH, QMH/A, QP, QP/A, QT, QT/A, RD, RD/A, RH, RH26, RH26/A, RSS, RSS/A, SD, SD/A, SH, SH/A, SJ, SJ/A, SJG, SJG/A, SK, SN, SN/A, SW, VH
			1	-	-	1056014	VSD3
			1	-	-	1110060	QE, SE, VXG
			1	-	-	1033680	1110060 QXB, SXB, VNG1, VSD, VXB
			1	-	-	1033680	1225386 HA, HX, LX, LXZ, PA, PX, QA, QX, QXC, RA, RX, SJP, SX, VA, VAW, VD16, VX
			-	-	1	1000009	VXP



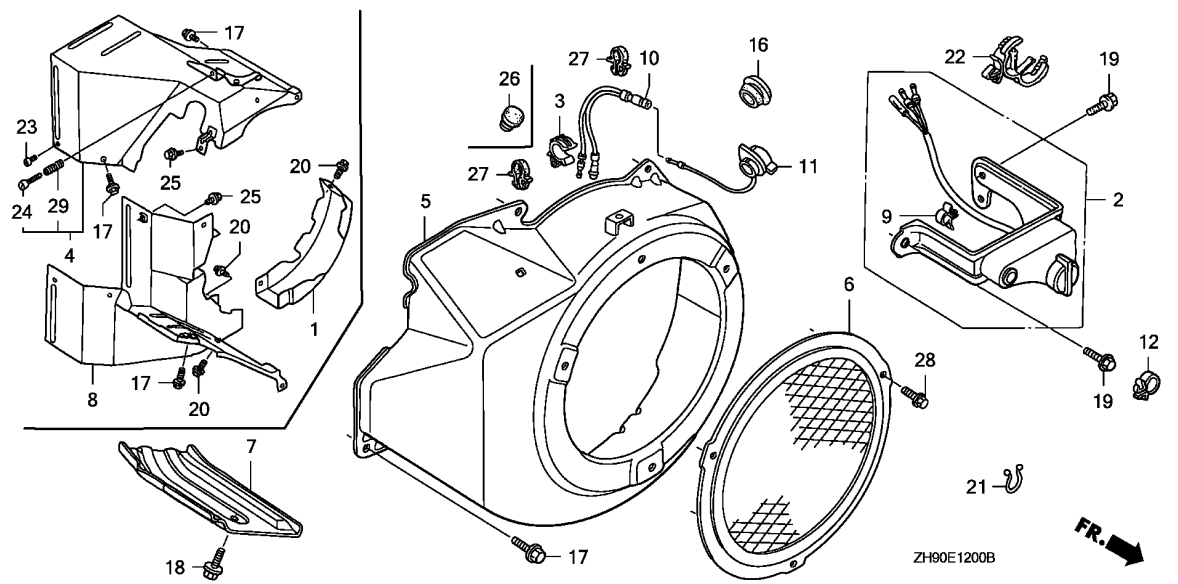

Ref. No.	Part No.	Description	Reqd. QTY			Serial No.	Parts catalogue code
			(1)	(2)	(3)		
11)	36100-ZH8-W41	SWITCH ASSY., ENGINE STOP ...	1	-	-	----- LHQ4, QE/A, QHQ4, QHQ4/A, QHR, QHR/A, RHQ4, RHQ4/A, SE/A, SHQ4, SHQ4/A	
			1	-	-	----- 1110061 ----- QE, SE	
			1	-	-	----- 1033679 VD16	
			1	-	-	----- 1225386 HXQ4, LXQ4, QAQ4, QXC4, QXQ4, RXQ4, SMC4, SME6, SWC4, SXQ4, VXQ4	
			1	-	-	----- 1110061 1225386 QXB, SXB, VNG1, VSD, VXB, VXG	
			-	-	1	----- 1000009 VXQP	
	36100-ZH7-W41	1	-	-	----- HXQ4/A, LXQ4/A, QAQ4/A, QWA4, QXB/A, QXB7, QXB7/A, QXC4/A, QXQ4/A, RXQ4/A	
						----- SMC4/A, SME6/A, SWA4, SXB/A, SXB7, SXB7/A, SXQ4/A, VKX4, VNG1/A, VN17	
						----- VN17/A, VSD/A, VSD7, VSD7/A, VSH7, VXB/A, VXB7, VXB7/A, VXQ4/A, VXTB	
			1	-	-	----- 1225387 ----- HXQ4, LXQ4, QAQ4, QXB, QXC4, QXQ4, RXQ4, SMC4, SME6, SWC4, SXB, SXQ4, VNG1	
						----- VSD, VXB, VXG, VXQ4	
			1	-	-	----- 2375749 QWA4/A, SWC4/A	
			-	-	1	----- 1000010 ----- VXQP	
	36100-ZH7-003	1	(1)	1	----- ES1, ES1/A, HAP, HAP/A, HA2/A, HX/A, HX26/A, HX8, HX8/A, LJC, LJC/A, LX/A	
						----- LXU, LXU/A, L1/A, PA2/A, PX/A, PXU, PXU/A, PX26/A, QAB3/A, QAG, QAG/A, QAG2	
						----- QAG2/A, QAR2/A, QAW, QL2, QWA2, QWH2, QWH2/A, QX/A, QXC6/A, QXU, QXU/A	
						----- QX26/A, Q1/A, RA2/A, RSC2/A, RX/A, RXP, RXP/A, RXU, RXU/A, R1/A, SMX2, SX/A	
						----- SXU, SXU/A, S1/A, VAG2, VAG2/A, VA2/A, VMX2, VM2, VM2/A, VNT2, VNT2/A	
						----- VWN2/A, VW12/A, VX/A, VXP/A, VXT1, VXT1/A, VXU/A, VXU1, VXU1/A, WMT8	
						----- WMT8/A, W1/A	
			1	(1)	-	----- 1225387 ----- HA, HAQ, HA2, HX, HX26, LX, LX2, LX16, L1, PA, PA2, PX, PX26, QA, QAB1, QAB3, QAQ	
						----- QAR2, QA2, QX, QXC, QXC6, QXC9, QX26, Q1, Q2, RA, RA2, RSC2, RX, R1, SJP, SMD, SX	
						----- SX2, S1, VA, VAW, VAW1, VA2, VD16, VWN2, VW12, VW22, VX, VXB2, VXB6, VXU, VX26	
						----- V1, W1	
			1	-	-	----- 2372800 QAW/A, QA2/A, QXC9/A	
			-	-	1	----- 1000010 ----- VXP	
	36100-ZF6-P81	1	-	-	----- VPX5	
			1	-	-	----- 2372801 ----- QAW/A, QA2/A, QXC9/A	
			1	-	-	----- 2375750 ----- QWA4/A, SWC4/A	

Ref. No.	Part No.	Description	Reqd. QTY			Serial No.	Parts catalogue code
			(1)	(2)	(3)		
12	36103-ZE1-000	HOLDER, STOP SWITCH CORD	1	-	-	-----	ESS,ESS/A,LHB5,LWD,QHB5
16	81329-567-020	GROMMET, DRAIN HOLE	1	-	-	-----	ESS,ESS/A,ES3,ES3/A,HEA,HEA2,HEA2/A,HEA8,HEA8/A,LHE,LHE/A,LTJ,LWD LWD1,LWD1/A,LXE,LXE/A,LXE8,LXE8/A,PAE2,PAE2/A,PXE8,PXE8/A,QAE QAE2,QAE2/A,QAE6,QAE6/A,QHE,QHE4,QHE4/A,QHR4,QHR4/A,QKE3,QKE3/A QKE4,QME2,QME2/A,QSC,QSC9,QSC9/A,QSE,QSE/A,QSE2,QSE8,QSE8/A,QXB6 QXB6/A,QXE,QXE/A,QXEB,QXE4,QXE4/A,QXE6,QXE6/A,QXE8,QXE8/A,RHE RHE4,RHE4/A,SHE,SHEZ,SKE1,SME1,SME1/A,SWE,SXE,SXE8,SXE8/A SXE4,SXE4/A,SXE8,SXE8/A,VDE,VDE2,VDE2/A,VEB6,VKB2,VKB2/A,VKE4 VMA4,VME2,VME2/A,VME4,VMS2,VMT,VMT/A,VPE4,VPE4/A,VPE5,VPE7,VPE7/A VPX4,VPX4/A,VPX7,VPX7/A,VSD3/A,VS3,VS37,VS37/A,VVA,VVA2,VVA2/A VWT4,VWT4/A,VXE,VXEB,VXEB/A,VXE4,VXE4/A,VXE6,VXE6/A,VXE7,VXE7/A WMA4,WXE8,WXE8/A
			1	-	-	1056015	VSD3
			1	-	-	1033679	HA,HX,LX,LXZ,PA,PX,QA,QX,QXB,QXC,RA,RX,SJP,SX,SBX,VA,VAW,VNG1,VSD VX,VXB
			-	(1)	-		
17	90013-883-000	BOLT, FLANGE, 6X12(CT200) ...	5	5	5		
18	90013-883-000	BOLT, FLANGE, 6X12(CT200) ...	1	-	-	-----	ES1,ES1/A,ES3,ES3/A,HA,HAQ,HA2,HA2/A,HEA2,HEA2/A,HEA8,HEA8/A,HH HX,HX/A,HXQ4,HXQ4/A,HX26,HX26/A,HX8,HX8/A,LH,LH/A,LHB1,LHB3,LHB5 LHE,LHE/A,LHQ4,LJ,LJ/A,LJC,LJC/A,LJG,LJG/A,LSS,LT,LT/A,LTJ,LW LW/A,LWD,LWD1,LWD1/A,LX,LX/A,LXE,LXE/A,LXE8,LXE8/A,LXQ4,LXQ4/A LXU,LXU/A,LXZ,LX16,PA,PAE2,PAE2/A,PA2,PA2/A,PX,PX/A,PXE8,PXE8/A PXU,PXU/A,PX26,PX26/A,QA,QAB1,QAB3,QAB3/A,QAE,QAE2,QAE2/A,QAE6 QAE6/A,QAG,QAG/A,QAG2,QAG2/A,QAQ,QAQ4,QAQ4/A,QAR2,QAR2/A,QAW QAW/A,QA2,QA2/A,QD,QD/A,QE,QE/A,QH,QH/A,QHB5,QHC,QHE,QHE4/A QHP1,QHP1/A,QHQ4,QHQ4/A,QHR,QHR/A,QHR4,QHR4/A,QHZ,QHZ/A,QH26 QH26/A,QKE3,QKE3/A,QKE4,QL2,QME2,QME2/A,QMH,QMH/A,QP,QP/A,QSC9 QSC9/A,QSE,QSE/A,QSE2,QSE8,QSE8/A,QT,QT/A,QWA2,QWA4,QWA4/A,QWH2 QWH2/A,QX,QX/A,QXB,QXB/A,QXB6,QXB6/A,QXB7,QXB7/A,QXC,QXC4,QXC4/A QXC6,QXC6/A,QXC9,QXC9/A,QXE,QXE/A,QXEB,QXE4,QXE4/A,QXE6,QXE6/A QXE8,QXE8/A,QXQ4,QXQ4/A,QXU,QXU/A,QX26,QX26/A,RA,RA2,RA2/A,RD RD/A,RH,RHE,RHE4,RHE4/A,RHQ4,RHQ4/A,RH26,RH26/A,RSC2,RSC2/A,RSS RSS/A,RX,RX/A,RXQ4,RXQ4/A,RXU,RXU/A,SD,SD/A,SE,SE/A,SH,SH/A,SHE SHEZ,SHQ4,SHQ4/A,SJ,SJ/A,SJG,SJG/A,SJP,SK,SKE1,SMC4,SMC4/A,SMD SME1,SME1/A,SME6,SME6/A,SMX2,SN,SN/A,SW,SWA4,SWC4,SWC4/A,SWE,SX SX/A,SBX,SBX/A,SBX7,SBX7/A,SXE,SXE/A,SBX,SBX/A,SXE4,SXE4/A,SBX8 SBX8/A,SXQ4,SXQ4/A,SXU,SXU/A,SX2,VA,VAG2,VAG2/A,VAW,VA2,VA2/A VDE2,VDE2/A,VD16,VEB6,VH,VKB2,VKB2/A,VKE4,VKX4,VMA4,VME2,VME2/A VME4,VMS2,VMT,VMT/A,VMX2,VM2,VM2/A,VNG1,VNG1/A,VNT2,VNT2/A,VN17 VN17/A,VPE4,VPE4/A,VPE5,VPE7,VPE7/A,VPX4,VPX4/A,VPX5,VPX7,VPX7/A VSD,VSD/A,VSD3,VSD3/A,VSD7,VSD7/A,VSH7,VS3,VS37,VS37/A,VVA2 VVA2/A,VVN2,VVN2/A,VWT4,VWT4/A,VW12,VW12/A,VW22,VX,VX/A,VXB,VXB/A VXB2,VXB6,VXB7,VXB7/A,VXE,VXEB,VXEB/A,VXE4,VXE4/A,VXE6,VXE6/A VXE7,VXE7/A,VXG,VXQ4,VXQ4/A,VXTB,VXT1,VXT1/A,VXU,VXU/A,VXU1 VXU1/A,VX26,WMA4,WMT8,WMT8/A,WXE8,WXE8/A
19	90013-883-000	BOLT, FLANGE, 6X12(CT200) ...	2	(2)	-	-----	1033679 HA,HX,LX,LXZ,L1,PA,PX,QA,QX,QXB,QXC,Q1,RA,RX,R1,SX,SBX,S1,VA,VAW VNG1,VSD,VX,VXB,V1,W1
			2	-	-	-----	VSD3/A,VS37/A
			2	-	-	1056015	VSD3,VS37
20	90019-883-000	BOLT, FLANGE, 5X10	3	-	-	-----	ESS,ESS/A
21	90630-751-000	CLIP, PURSE LOCK	1	-	-	-----	LWD



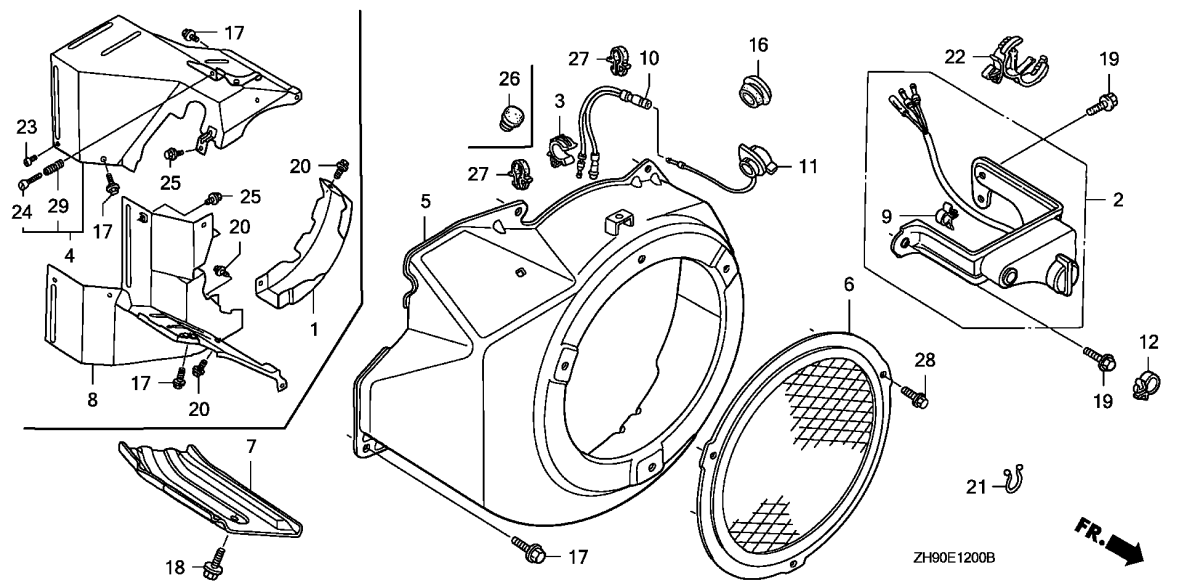

Ref. No.	Part No.	Description	Reqd. QTY			Serial No.	Parts catalogue code
			(1)	(2)	(3)		
22	90684-ZA0-601	CLIP, HARNESS	1	(1)	-	-----	ES1,ES1/A,HA,HAQ,HA2,HA2/A,HX,HX/A,HXQ4,HXQ4/A,HX26,HX26/A,HX8 HX8/A,LJC,LJC/A,LX,LX/A,LXQ4,LXQ4/A,LXU,LXU/A,LXZ,LX16,L1,L1/A,PA PA2,PA2/A,PX,PX/A,PXU,PXU/A,PX26,PX26/A,QA,QAB1,QAB3,QAB3/A,QAG QAG/A,QAG2,QAG2/A,QAQ,QAQ4,QAQ4/A,QAR2,QAR2/A,QAW,QAW/A,QA2,QA2/A QWA4,QWA4/A,QWH2,QWH2/A,QX,QX/A,QXB,QXB/A,QXC,QXC4,QXC4/A,QXC6 QXC6/A,QXC9,QXC9/A,QXQ4,QXQ4/A,QXU,QXU/A,QX26,QX26/A,Q1,Q1/A,RA RA2,RA2/A,RSC2,RSC2/A,RX,RX/A,RXQ4,RXQ4/A,RXU,RXU/A,R1,R1/A,SJP SMC4,SMC4/A,SMD,SME6,SME6/A,SMX2,SWA4,SWC4,SWC4/A,SX,SX/A, SXB/A,SXQ4,SXQ4/A,SXU,SXU/A,SX2,S1,S1/A,VA,VAG2,VAG2/A,VAW,VAW1 VA2,VA2/A,VD16,VKX4,VMX2,VM2,VM2/A,VNG1,VNG1/A,VNT2,VNT2/A, VN17/A,VPX4,VPX4/A,VPX5,VSD,VSD/A,VSD3,VSD3/A,VWA,VWA2,VWA2/A VWN2,VWN2/A,VW12,VW12/A,VW22,VX,VX/A,VXB,VXB/A,VXB2,VXB6,VXG,VXQ4 VXQ4/A,VXTB,VXT1,VXT1/A,VXU,VXU/A,VXU1,VXU1/A,VX26,V1,WMT8,WMT8/A W1,W1/A
			1	-	-	-----	1284916 VPE4
23	93500-05008-0A	SCREW, PAN, 5X8	1	-	1	-----	ESS,ESS/A
24	93500-05032-0A	SCREW, PAN, 5X32	1	-	-	-----	ESS,ESS/A
25	90008-ZE2-003	BOLT, FLANGE, 6X10	3	-	-	-----	ESS,ESS/A
26	50317-254-000	PLUG, USELESS HOLE	-	-	1	-----	
27	90654-SA4-003	CLIP, WIRE HARNESS, 6MM(WHITE)	2	-	-	-----	ES3,ES3/A,VMT,VMT/A,VS3
28	95701-06008-00	BOLT, FLANGE, 6X8	3	-	-	-----	QKE3,SKE1
	90008-ZE2-003	BOLT, FLANGE, 6X10	3	-	-	-----	LWD,LWD1,LWD1/A,QKE3/A
29	16584-883-300	SPRING, CONTROL ADJUSTING	1	-	-	-----	ESS,ESS/A

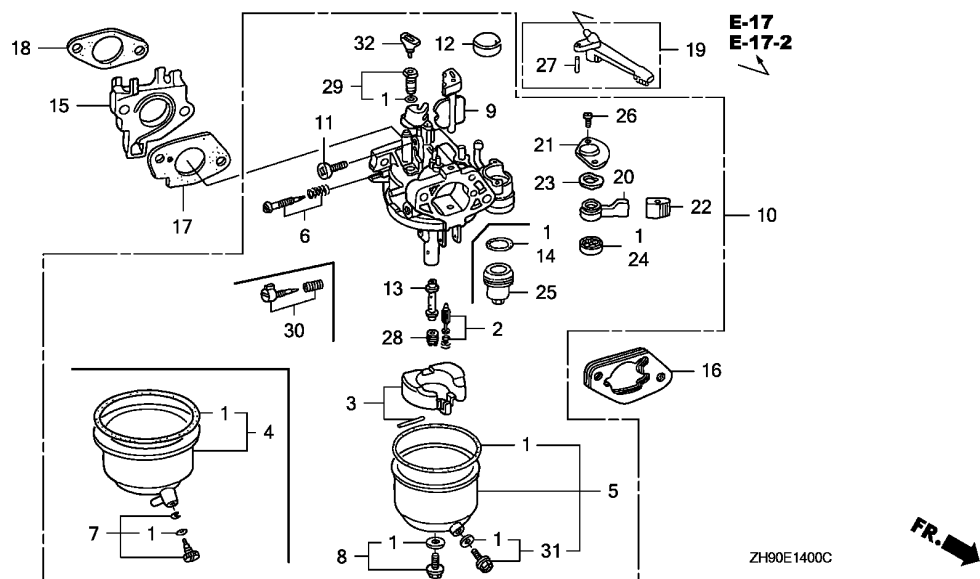

Ref. No.	L.O.N.	(Relative ref. Number) Description	F.R.T.
1	3111B1	GASKET SET, CARBURETOR (3)	0.3
2	3111E1	VALVE SET, FLOAT AND/OR FLOAT SET (30)	0.3
6	3111D7	SCREW SET, PILOT	0.2
10	3111F3	CARBURETOR	0.2
14	3101L6	PACKING, FUEL STRAINER CUP (18)	0.2
15	3111C0	INSULATOR, CARBURETOR AND/OR PACKING, INSULATOR	0.2
16	3111D9	SPACER, CARBURETOR	0.2
17	3111C8	PACKING, CARBURETOR	0.2
19	8101F9	LEVER, CARBURETOR CHOKE	0.2
24	3101C5	PACKING, FUEL COCK	0.2
28	3111C3	JET, MAIN	0.3

Ref. No.	Part No.	Description	Reqd. QTY			Serial No.	Parts catalogue code
			(1)	(2)	(3)		
1	16010-ZE2-015	GASKET SET	1	(1)	-	ES1,HA,HEA,HH,LHB1,LHB3,LHQ4,LJ,LJC,LJG,LSS,LT,LTJ,LW,LWD1,LXZ,L1 PA,QA,QAB1,QAE,QD,QD/A,QE,QHC,QHE,QKE3,QP,QSC,QT,QXC,QXC4,QXC4/A QXEB,Q1,Q2,RA,RD,RD/A,RHE,R1,SD,SD/A,SE,SHE,SHEZ,SJ,SJG,SJP,SK SKE1,SMC4,SMC4/A,SME6,SN,SN/A,SW,SWE,S1,VA,VAW,VAW1,VWA,VWT4,VXT1 V1,W1	
		(CARBURETOR NO.)	1	-	-	BE21A B LX16,VD16,VEB6	
		//	1	-	-	BE21A C ES1/A,HX,HXQ4,HX8,LH,LHE,LJ/A,LJC/A,LJG/A,LT/A,LW/A,LWD1/A,LX,LXE LXE8,LXQ4,LXU,PX,PXU,QAB3,QAQ4,QE/A,QH,QHE4,QHP1,QHQ4,QHZ,QKE3/A QME2,QMH,QP/A,QSE,QSE8,QT/A,QX,QXB,QXE,QXE4,QXE8,QXQ4,QXU,RH,RHE4 RHQ4,RX,RXQ4,RXU,SE/A,SH,SHQ4,SJ/A,SJG/A,SMD,SME1,SME6/A,SWC4,SX SXB,SXE,SXEB,SXE4,SXE8,SXQ4,SXU,VDE,VH,VNG1,VSD,VWT4/A,VX,VXB,VXE VXEB,VXE4,VXG,VXQ4,VXTB,VXT1/A,VXU,VXU1	
		//	1	-	-	BE21B B WMT8	
		//	-	(1)	-	BE21B B L1/A,Q1/A,R1/A,S1/A,W1/A	
		//	-	(1)	-	BE21A C L1/A,Q1/A,R1/A,S1/A,W1/A	
		//	-	(1)	-	BE24B C L1/A,Q1/A,R1/A,S1/A,W1/A	



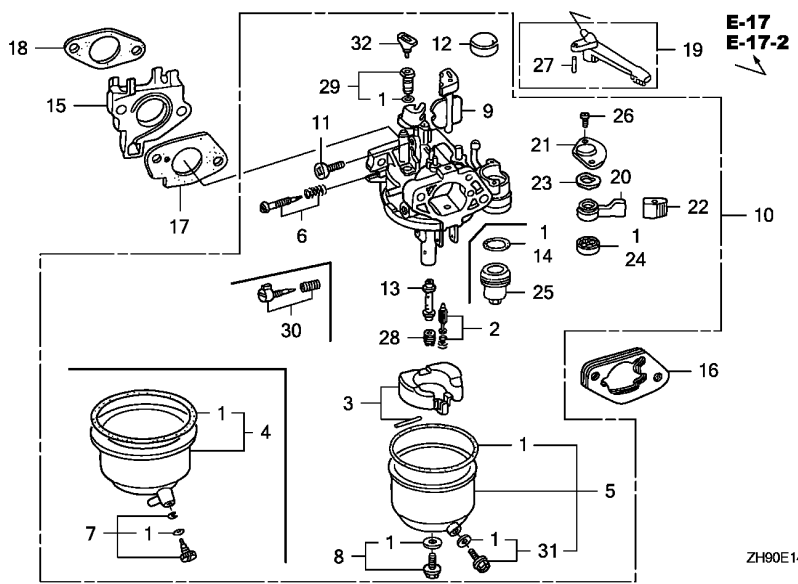

2

Ref. No.	Part No.	Description	Reqd. QTY			Serial No.	Parts catalogue code
			(1)	(2)	(3)		
(1)	16010-ZE2-812	GASKET SET (CARBURETOR NO.)	1	-	-	WMA4	L1/A,Q1/A,R1/A,S1/A,W1/A
			1	(1)	-	BE21A D	HAQ,HA2,HA2/A,HEA2,HEA2/A,HEA8,HEA8/A,HX/A,HXQ4/A,HX26,HX26/A,HX8/A,LH/A,LHB5,LHE/A,LX/A,LXE/A,LXE8/A,LXQ4/A,LXU/A,PAE2,PAE2/A,PA2,PA2/A,PX/A,PXE8,PXE8/A,PXU/A,PX26,PX26/A,QAB3/A,QAE2,QAE2/A,QAE6,QAE6/A,QAG,QAG/A,QAG2,QAG2/A,QAQ,QAQ4/A,QAR2,QAR2/A,QAW,QAW/A,QA2,QA2/A,QH/A,QHB5,QHE4/A,QHP1/A,QHQ4/A,QHR,QHR/A,QHR4,QHR4/A,QHZ/A,QH26,QH26/A,QKE4,QL2,QME2/A,QMH/A,QSC9,QSC9/A,QSE/A,QSE2,QSE8/A,QWA2,QWA4,QWA4/A,QWH2,QWH2/A,QX/A,QXB/A,QXB6,QXB6/A,QXB7,QXB7/A,QXC6,QXC6/A,QXC9,QXC9/A,QXE/A,QXE4/A,QXE6,QXE6/A,QXE8/A,QXQ4/A,QXU/A,QX26,QX26/A,RA2,RA2/A,RHE4/A,RHQ4/A,RH26,RH26/A,RSC2,RSC2/A,RSS,RSS/A,RX/A,RXQ4/A,RXU/A,SH/A,SHQ4/A,SME1/A,SMX2,SWA4,SWC4/A,SX/A,SXB/A,SXB7,SXB7/A,SXE/A,SXEB/A,SXE4/A,SXE8/A,SXQ4/A,SXU/A,SX2,VAG2,VAG2/A,VA2,VA2/A,VDE2,VDE2/A,VKB2,VKB2/A,VMA4,VME2,VME2/A,VME4,VM2,VM2/A,VNG1/A,VNT2,VNT2/A,VN17,VN17/A,VSD/A,VSD7,VSD7/A,VSH7,VWA2,VWA2/A,VWN2,VWN2/A,VW12,VW12/A,VW22,VX/A,VXB/A,VXB2,VXB6,VXB7,VXB7/A,VXEB/A,VXE4/A,VXE6,VXE6/A,VXE7,VXE7/A,VXQ4/A,VXU/A,VXU1/A,VX26,WMA4,WMT8/A,WXE8,WXE8/A,ES1/A,LJ/A,LJC/A,LJG/A,LT/A,LW/A,LWD1/A,QE/A,QKE3/A,QP/A,QT/A,SE/A,SJ/A,SJG/A,SME6/A,VWT4/A,VXT1/A
		(CARBURETOR NO.)	1	-	-	BE21A D	HX,HXQ4,HX8,LH,LHE,LX,LXE,LXE8,LXQ4,LXU,LX16,PX,PXU,QAB3,QAQ4,QH,QHE4,QHP1,QHQ4,QHZ,QME2,QMH,QSE,QSE8,QX,QXB,QXE4,QXE8,QXQ4,QXU,RH,RHE4,RHQ4,RX,RXQ4,RXU,SH,SHQ4,SMD,SME1,SWC4,SX,SXB,SXE,SXEB,SXE4,SXE8,SXQ4,SXU,VDE,VD16,VEB6,VH,VNG1,VSD,VX,VXB,VXE,VXE8,VXE4,VXG,VXQ4,VXTB,VXU,VXU1
		//	1	-	-	BE75B B	WMT8
		//	1	-	-	BE17B A	LWD
		//	-	(1)	-	BE24B D	L1/A,Q1/A,R1/A,S1/A,W1/A

Ref. No.	Part No.	Description	Reqd. QTY			Serial No.	Parts catalogue code
			(1)	(2)	(3)		
(1)	16010-ZE2-A20	GASKET SET (CARBURETOR NO.)	1	-	-	BE17B B	LWD
2	16011-ZA0-931	VALVE SET, FLOAT	1	-	-		ES1, ES1/A, HA, HAQ, HA2, HA2/A, HEA, HEA2, HEA2/A, HEA8, HEA8/A, HH, HX, HX/A, HXQ4, HXQ4/A, HX26, HX26/A, HX8, HX8/A, LH, LH/A, LHB1, LHB3, LHB5, LHE, LHE/A, LHQ4, LJ, LJ/A, LJC, LJC/A, LJG, LJG/A, LSS, LT, LT/A, LTJ, LW, LW/A, LWD, LWD1, LWD1/A, LX, LX/A, LXE, LXE/A, LXE8, LXE8/A, LXQ4, LXQ4/A, LXU, LXU/A, LXZ, LX16, PA, PAE2, PAE2/A, PA2, PA2/A, PX, PX/A, PXE8, PXE8/A, PXU, PXU/A, PX26, PX26/A, QA, QAB1, QAB3, QAB3/A, QAE, QAE2, QAE2/A, QAE6, QAE6/A, QAG, QAG/A, QAG2, QAG2/A, QAQ, QAQ4, QAR2, QAR2/A, QAW, QAW/A, QA2, QA2/A, QD, QD/A, QE, QE/A, QH, QH/A, QHB5, QHC, QHE, QHE4, QHE4/A, QHP1, QHP1/A, QHQ4, QHQ4/A, QHR, QHR/A, QHR4, QHR4/A, QHZ, QHZ/A, QH26, QH26/A, QKE3, QKE3/A, QKE4, QL2, QME2, QME2/A, QMH, QMH/A, QP, QP/A, QSC, QSC9, QSC9/A, QSE, QSE/A, QSE2, QSE8, QSE8/A, QT, QT/A, QWA2, QWA4, QWA4/A, QWH2, QWH2/A, QX, QX/A, QXB, QXB/A, QXB6, QXB6/A, QXB7, QXB7/A, QXC, QXC4, QXC4/A, QXC6, QXC6/A, QXC9, QXC9/A, QXE, QXE/A, QXEB, QXE4, QXE4/A, QXE6, QXE6/A, QXE8, QXE8/A, QXQ4, QXQ4/A, QXU, QXU/A, QX26, QX26/A, RA, RA2, RA2/A, RD, RD/A, RH, RHE, RHE4, RHE4/A, RHQ4, RHQ4/A, RH26, RH26/A, RSC2, RSC2/A, RSS, RSS/A, RX, RX/A, RXQ4, RXQ4/A, RXU, RXU/A, SD, SD/A, SE, SE/A, SH, SH/A, SHE, SHEZ, SHQ4, SHQ4/A, SJ, SJ/A, SJG, SJG/A, SJP, SK, SKE1, SMC4, SMC4/A, SMD, SME1, SME1/A, SME6, SME6/A, SMX2, SN, SN/A, SW, SWA4, SWC4, SWC4/A, SWE, SX, SX/A, SXB, SXB/A, SXB7, SXB7/A, SXE, SXE/A, SXEB, SXEB/A, SXE4, SXE4/A, SXE8, SXE8/A, SXQ4, SXQ4/A, SXU, SXU/A, SX2, VA, VAG2, VAG2/A, VAW, VAW1, VA2, VA2/A, VDE, VDE2, VDE2/A, VD16, VEB6, VH, VKB2, VKB2/A, VMA4, VME2, VME2/A, VME4, VM2, VM2/A, VNG1, VNG1/A, VNT2, VNT2/A, VN17, VN17/A, VSD, VSD/A, VSD7, VSD7/A, VSH7, VWA, VWA2, VWA2/A, VWN2, VWN2/A, VWT4, VWT4/A, VW12, VW12/A, VW22, VX, VX/A, VXB, VXB/A, VXB2, VXB6, VXB7, VXB7/A, VXE, VXE8, VXE8/A, VXE4, VXE4/A, VXE6, VXE6/A, VXE7, VXE7/A, VXG, VXQ4, VXQ4/A, VXTB, VXT1, VXT1/A, VXU, VXU/A, VXU1, VXU1/A, VX26, WMA4, WMT8, WMT8/A, WXE8, WXE8/A
3	16013-ZA0-931	FLOAT SET	-	(1)	-		ES1, ES1/A, HA, HAQ, HA2, HA2/A, HEA, HEA2, HEA2/A, HEA8, HEA8/A, HH, HX, HX/A, HXQ4, HXQ4/A, HX26, HX26/A, HX8, HX8/A, LH, LH/A, LHB1, LHB3, LHB5, LHE, LHE/A, LHQ4, LJ, LJ/A, LJC, LJC/A, LJG, LJG/A, LSS, LT, LT/A, LTJ, LW, LW/A, LWD, LWD1, LWD1/A, LX, LX/A, LXE, LXE/A, LXE8, LXE8/A, LXQ4, LXQ4/A, LXU, LXU/A, LXZ, LX16, PA, PAE2, PAE2/A, PA2, PA2/A, PX, PX/A, PXE8, PXE8/A, PXU, PXU/A, PX26, PX26/A, QA, QAB1, QAB3, QAB3/A, QAE, QAE2, QAE2/A, QAE6, QAE6/A, QAG, QAG/A, QAG2, QAG2/A, QAQ, QAQ4, QAR2, QAR2/A, QAW, QAW/A, QA2, QA2/A, QD, QD/A, QE, QE/A, QH, QH/A, QHB5, QHC, QHE, QHE4, QHE4/A, QHP1, QHP1/A, QHQ4, QHQ4/A, QHR, QHR/A, QHR4, QHR4/A, QHZ, QHZ/A, QH26, QH26/A, QKE3, QKE3/A, QKE4, QL2, QME2, QME2/A, QMH, QMH/A, QP, QP/A, QSC, QSC9, QSC9/A, QSE, QSE/A, QSE2, QSE8, QSE8/A, QT, QT/A, QWA2, QWA4, QWA4/A, QWH2, QWH2/A, QX, QX/A, QXB, QXB/A, QXB6, QXB6/A, QXB7, QXB7/A, QXC, QXC4, QXC4/A, QXC6, QXC6/A, QXC9, QXC9/A, QXE, QXE/A, QXEB, QXE4, QXE4/A, QXE6, QXE6/A, QXE8, QXE8/A, QXQ4, QXQ4/A, QXU, QXU/A, QX26, QX26/A, RA, RA2, RA2/A, RD, RD/A, RH, RHE, RHE4, RHE4/A, RHQ4, RHQ4/A, RH26, RH26/A, RSC2, RSC2/A, RSS, RSS/A, RX, RX/A, RXQ4, RXQ4/A, RXU, RXU/A, SD, SD/A, SE, SE/A, SH, SH/A, SHE, SHEZ, SHQ4, SHQ4/A, SJ, SJ/A, SJG, SJG/A, SJP, SK, SKE1, SMC4, SMC4/A, SMD, SME1, SME1/A, SME6, SME6/A, SMX2, SN, SN/A, SW, SWA4, SWC4, SWC4/A, SWE, SX, SX/A, SXB, SXB/A, SXB7, SXB7/A, SXE, SXE/A, SXEB, SXEB/A, SXE4, SXE4/A, SXE8, SXE8/A, SXQ4, SXQ4/A, SXU, SXU/A, SX2, VA, VAG2, VAG2/A, VAW, VAW1, VA2, VA2/A, VDE, VDE2, VDE2/A, VD16, VEB6, VH, VKB2, VKB2/A, VMA4, VME2, VME2/A, VME4, VM2, VM2/A, VNG1, VNG1/A, VNT2, VNT2/A, VN17, VN17/A, VSD, VSD/A, VSD7, VSD7/A, VSH7, VWA, VWA2, VWA2/A, VWN2, VWN2/A, VWT4, VWT4/A, VW12, VW12/A, VW22, VX, VX/A, VXB, VXB/A, VXB2, VXB6, VXB7, VXB7/A, VXE, VXE8, VXE8/A, VXE4, VXE4/A, VXE6, VXE6/A, VXE7, VXE7/A, VXG, VXQ4, VXQ4/A, VXTB, VXT1, VXT1/A, VXU, VXU/A, VXU1, VXU1/A, VX26, WMA4, WMT8, WMT8/A, WXE8, WXE8/A
4	16015-ZE2-A20	CHAMBER SET, FLOAT (CARBURETOR NO.)	1	-	-	BE17B B	LWD



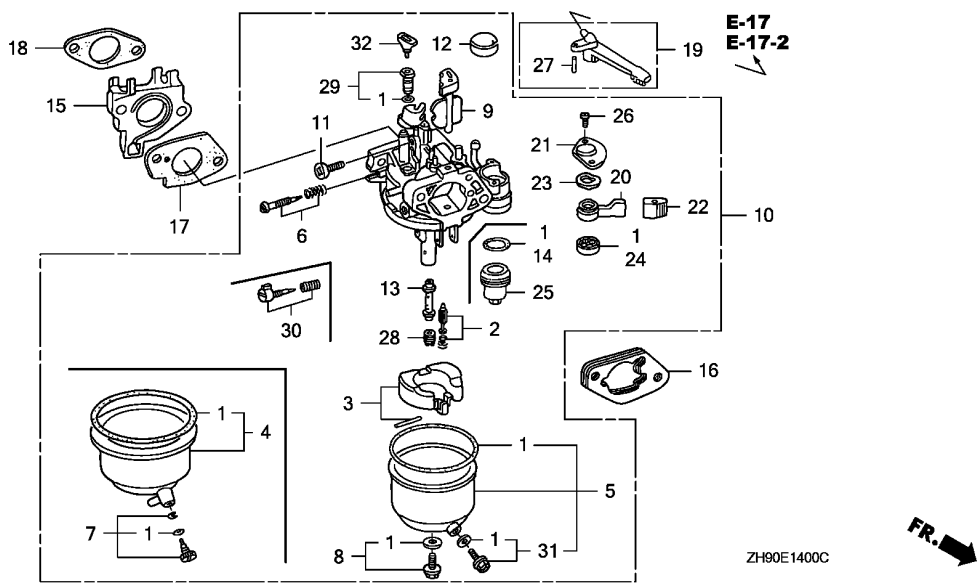

2

Ref. No.	Part No.	Description	Reqd. QTY			Serial No.	Parts catalogue code
			(1)	(2)	(3)		
5	16015-ZE8-005	CHAMBER SET, FLOAT	1	-	-	-----	ES1,ES1/A,HA,HAQ,HA2,HA2/A,HEA,HEA2,HEA2/A,HEA8,HEA8/A,HH,HX,HX/A,HXQ4,HXQ4/A,HX26,HX26/A,HX8,HX8/A,LH,LH/A,LHB1,LHB3,LHB5,LHE,LHE/A,LHQ4,LJ,LJ/A,LJC,LJC/A,LJG,LJG/A,LSS,LT,LT/A,LTJ,LW,LW/A,LWD1,LWD1/A,LX,LX/A,LXE,LXE/A,LXE8,LXE8/A,LXQ4,LXQ4/A,LXU,LXU/A,LXZ,LX16,PA,PAE2,PAE2/A,PA2,PA2/A,PX,PX/A,PXE8,PXE8/A,PXU,PXU/A,PX26,PX26/A,QA,QAB1,QAB3,QAB3/A,QAE,QAE2,QAE2/A,QAE6,QAE6/A,QAG,QAG/A,QAG2,QAG2/A,QAQ,QAQ4,QAQ4/A,QAR2,QAR2/A,QAW,QAW/A,QA2,QA2/A,QD,QD/A,QE,QE/A,QH,QH/A,QHB5,QHC,QHE,QHE4,QHE4/A,QHP1,QHP1/A,QHQ4,QHQ4/A,QHR,QHR/A,QHR4,QHR4/A,QHZ,QHZ/A,QH26,QH26/A,QKE3,QKE3/A,QKE4,QL2,QME2,QME2/A,QMH,QMH/A,QP,QP/A,QSC,QSC9,QSC9/A,QSE,QSE/A,QSE2,QSE8,QSE8/A,QT,QT/A,QWA2,QWA4,QWA4/A,QWH2,QWH2/A,QX,QX/A,QXB,QXB/A,QXB6,QXB6/A,QXB7,QXB7/A,QXC,QXC4,QXC4/A,QXC6,QXC6/A,QXC9,QXC9/A,QXE,QXE/A,QXEB,QXE4,QXE4/A,QXE6,QXE6/A,QXE8,QXE8/A,QXQ4,QXQ4/A,QXU,QXU/A,QX26,QX26/A,RA,RA2,RA2/A,RD,RD/A,RH,RHE,RHE4,RHE4/A,RHQ4,RHQ4/A,RH26,RH26/A,RSC2,RSC2/A,RSS,RSS/A,RX,RX/A,RXQ4,RXQ4/A,RXU,RXU/A,SD,SD/A,SE,SE/A,SH,SH/A,SHE,SHEZ,SHQ4,SHQ4/A,SJ,SJ/A,SJG,SJG/A,SJP,SK,SK1,SMC4,SMC4/A,SMD,SME1,SME1/A,SME6,SME6/A,SMX2,SN,SN/A,SW,SWA4,SWC4,SWC4/A,SWE,SX,SX/A,SXB,SXB/A,SXB7,SXB7/A,SXE,SXE/A,SXEB,SXEB/A,SXE4,SXE4/A,SXE8,SXE8/A,SXQ4,SXQ4/A,SXU,SXU/A,SX2,VA,VAG2,VAG2/A,VAW,VAW1,VA2,VA2/A,VDE,VDE2,VDE2/A,VD16,VEB6,VH,VKB2,VKB2/A,VMA4,VME2,VME2/A,VME4,VM2,VM2/A,VNG1,VNG1/A,VNT2,VNT2/A,VN17,VN17/A,VSD,VSD/A,VSD7,VSD7/A,VSH7,VNA,VNA2,VNA2/A,VWN2,VWN2/A,VWT4,VWT4/A,VW12,VW12/A,VW22,VX,VX/A,VXB,VXB/A,VXB2,VXB6,VXB7,VXB7/A,VXE,VXEB,VXEB/A,VXE4,VXE4/A,VXE6,VXE6/A,VXE7,VXE7/A,VXG,VXQ4,VXQ4/A,VXTB,VXT1,VXT1/A,VXU,VXU/A,VXU1,VXU1/A,VX26,WMA4,WMT8,WMT8/A,WXE8,WXE8/A

- (1) -

Ref. No.	Part No.	Description	Reqd. QTY			Serial No.	Parts catalogue code
			(1)	(2)	(3)		
6	16016-ZA0-931	SCREW SET, PILOT	1	(1)	-	-----	ES1, HA, HEA, HH, LHB1, LHB3, LHQ4, LJ, LJC, LJG, LSS, LT, LTJ, LW, LWD1, LXZ, L1 PA, QA, QAB1, QAE, QD, QE, QHE, QKE3, QP, QT, QXEB, Q1, Q2, RA, RD, RHE, R1, SD, SE SHE, SHEZ, SJ, SJG, SJP, SK, SKE1, SMC4, SME6, SN, SW, SWE, S1, VA, VAW, VAW1 VWA, VWT4, VXT1, V1, W1
		(CARBURETOR NO.)	1	(1)	-	-----	BE21B B L1/A, QD/A, Q1/A, RD/A, R1/A, SD/A, SMC4/A, SN/A, S1/A, WMT8, W1/A
		//	1	-	-	-----	BE21A C ES1/A, HX, HXQ4, HX8, LH, LHE, LJ/A, LJC/A, LJG/A, LT/A, LW/A, LWD1/A, LX, LXE LXE8, LXQ4, LXU, LX16, PX, PXU, QAB3, QAQ4, QE/A, QH, QHE4, QHP1, QHQ4, QHZ QKE3/A, QME2, QMH, QP/A, QSE, QSE8, QT/A, QX, QXB, QXE, QXE4, QXE8, QXQ4, QXU RH, RHE4, RHQ4, RX, RXQ4, RXU, SE/A, SH, SHQ4, SJ/A, SJG/A, SMD, SME1, SME6/A SWC4, SX, SXB, SXE, SXEB, SXE4, SXE8, SXQ4, SXU, VDE, VD16, VEB6, VH, VNG1, VSD VWT4/A, VX, VXB, VXE, VXEB, VXE4, VXG, VXQ4, VXTB, VXT1/A, VXU, VXU1
	16016-ZE0-005	1	(1)	-	-----	LWD, L1, QHC, QSC, QXC, QXC4, Q1, Q2, R1, S1, V1, W1
		(CARBURETOR NO.)	1	(1)	-	-----	BE24B C L1/A, QXC4/A, Q1/A, R1/A, S1/A, W1/A
	16016-ZA0-931	-	(1)	-	-----	BE21A C L1/A, Q1/A, R1/A, S1/A, W1/A
		(CARBURETOR NO.)	-	(1)	-	-----	BE17B B ----- LWD
7	16024-ZH7-A20	SCREW SET, DRAIN	1	-	-	-----	LWD
		(CARBURETOR NO.)	1	-	-	-----	BE17B B ----- LWD
8	16028-ZE0-005	SCREW SET	1	-	-	-----	ES1, ES1/A, HA, HAQ, HA2, HA2/A, HEA, HEA2, HEA2/A, HEA8, HEA8/A, HH, HX, HX/A HXQ4, HXQ4/A, HX26, HX26/A, HX8, HX8/A, LH, LH/A, LHB1, LHB3, LHB5, LHE LHE/A, LHQ4, LJ, LJ/A, LJC, LJC/A, LJG, LJG/A, LSS, LT, LT/A, LTJ, LW, LW/A LWD, LWD1, LWD1/A, LX, LX/A, LXE, LXE/A, LXE8, LXE8/A, LXQ4, LXQ4/A, LXU LXU/A, LXZ, LX16, PA, PAE2, PAE2/A, PA2, PA2/A, PX, PX/A, PXE8, PXE8/A, PXU PXU/A, PX26, PX26/A, QA, QAB1, QAB3, QAB3/A, QAE, QAE2, QAE2/A, QAE6, QAE6/A QAG, QAG/A, QAG2, QAG2/A, QAQ, QAQ4, QAQ4/A, QAR2, QAR2/A, QAW, QAW/A, QA2 QA2/A, QD, QD/A, QE, QE/A, QH, QH/A, QHB5, QHC, QHE, QHE4, QHE4/A, QHP1 QHP1/A, QHQ4, QHQ4/A, QHR, QHR/A, QHR4, QHR4/A, QHZ, QHZ/A, QH26, QH26/A QKE3, QKE3/A, QKE4, QL2, QME2, QME2/A, QMH, QMH/A, QP, QP/A, QSC, QSC9 QSC9/A, QSE, QSE/A, QSE2, QSE8, QSE8/A, QT, QT/A, QWA2, QWA4, QWA4/A, QWH2 QWH2/A, QX, QX/A, QXB, QXB/A, QXB6, QXB6/A, QXB7, QXB7/A, QXC, QXC4, QXC4/A QXC6, QXC6/A, QXC9, QXC9/A, QXE, QXE/A, QXEB, QXE4, QXE4/A, QXE6, QXE6/A QXE8, QXE8/A, QXQ4, QXQ4/A, QXU, QXU/A, QX26, QX26/A, RA, RA2, RA2/A, RD RD/A, RH, RHE, RHE4, RHE4/A, RHQ4, RHQ4/A, RH26, RH26/A, RSC2, RSC2/A, RSS RSS/A, RX, RX/A, RXQ4, RXQ4/A, RXU, RXU/A, SD, SD/A, SE, SE/A, SH, SH/A, SHE SHEZ, SHQ4, SHQ4/A, SJ, SJ/A, SJG, SJG/A, SJP, SK, SKE1, SMC4, SMC4/A, SMD SME1, SME1/A, SME6, SME6/A, SMX2, SN, SN/A, SW, SWA4, SWC4, SWC4/A, SWE, SX SX/A, SXB, SXB/A, SXB7, SXB7/A, SXE, SXE/A, SXEB, SXEB/A, SXE4, SXE4/A, SXE8 SXE8/A, SXQ4, SXQ4/A, SXU, SXU/A, SX2, VA, VAG2, VAG2/A, VAW, VAW1, VA2 VA2/A, VDE, VDE2, VDE2/A, VD16, VEB6, VH, VKB2, VKB2/A, VMA4, VME2, VME2/A VME4, VM2, VM2/A, VNG1, VNG1/A, VNT2, VNT2/A, VN17, VN17/A, VSD, VSD/A, VSD7 VSD7/A, VSH7, VWA, VWA2, VWA2/A, VWN2, VWN2/A, VWT4, VWT4/A, VW12, VW12/A VW22, VX, VX/A, VXB, VXB/A, VXB2, VXB6, VXB7, VXB7/A, VXE, VXE6, VXE6/A, VXE4 VXE4/A, VXE6, VXE6/A, VXE7, VXE7/A, VXG, VXQ4, VXQ4/A, VXTB, VXT1, VXT1/A VXU, VXU/A, VXU1, VXU1/A, VX26, WMA4, WMT8, WMT8/A, WXE8, WXE8/A
			-	(1)	-	-----	



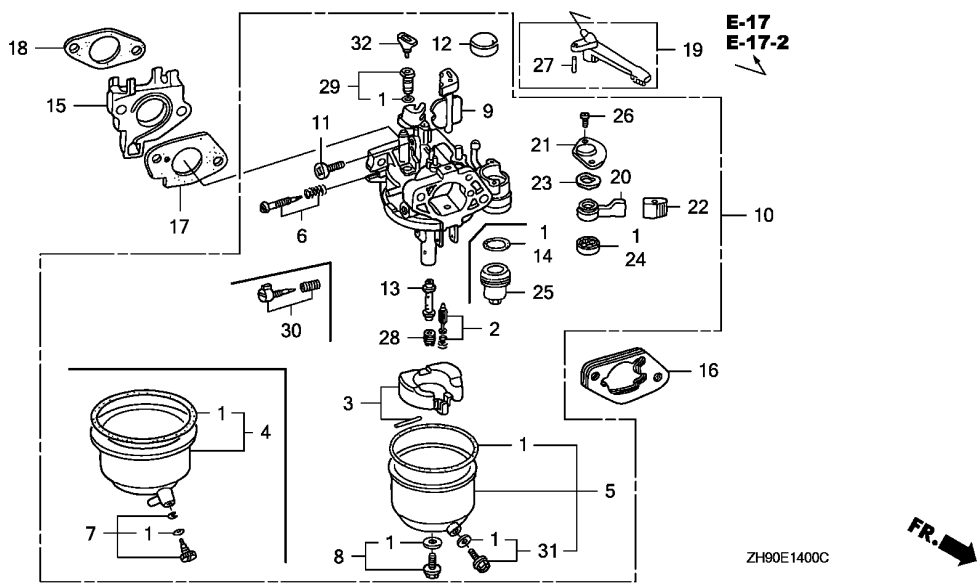

Ref. No.	Part No.	Description	Reqd. QTY			Serial No.	Parts catalogue code
			(1)	(2)	(3)		
9	16044-ZE2-005	CHOKE SET	1	-	-	-----	ES1,ES1/A,HA,HAQ,HA2,HA2/A,HEA,HEA2,HEA2/A,HEA8,HEA8/A,HH,HX,HX/A,HXQ4,HXQ4/A,HX26,HX26/A,HX8,HX8/A,LH,LH/A,LHB1,LHB3,LHB5,LHE,LHE/A,LHQ4,LJ,LJ/A,LJC,LJC/A,LJG,LJG/A,LSS,LT,LT/A,LTJ,LW,LW/A,LWD1,LWD1/A,LX,LX/A,LXE,LXE/A,LXE8,LXE8/A,LXQ4,LXQ4/A,LXU,LXU/A,LXZ,LX16,PA,PAE2,PAE2/A,PA2,PA2/A,PX,PX/A,PXE8,PXE8/A,PXU,PXU/A,PX26,PX26/A,QA,QAB1,QAB3,QAB3/A,QAE,QAE2,QAE2/A,QAE6,QAE6/A,QAG,QAG/A,QAG2,QAG2/A,QAQ,QAQ4,QAQ4/A,QAR2,QAR2/A,QAW,QAW/A,QA2,QA2/A,QD,QD/A,QE,QE/A,QH,QH/A,QHB5,QHC,QHE,QHE4,QHE4/A,QHP1,QHP1/A,QHQ4,QHQ4/A,QHR,QHR/A,QHR4,QHR4/A,QHZ,QHZ/A,QH26,QH26/A,QKE3,QKE3/A,QKE4,QL2,QME2,QME2/A,QMH,QMH/A,QP,QP/A,QSC,QSC9,QSC9/A,QSE,QSE/A,QSE2,QSE8,QSE8/A,QT,QT/A,QWA2,QWA4,QWA4/A,QWH2,QWH2/A,QX,QX/A,QXB,QXB/A,QXB6,QXB6/A,QXB7,QXB7/A,QXC,QXC4,QXC4/A,QXC6,QXC6/A,QXC9,QXC9/A,QXE,QXE/A,QXEB,QXE4,QXE4/A,QXE6,QXE6/A,QXE8,QXE8/A,QXQ4,QXQ4/A,QXU,QXU/A,QX26,QX26/A,RA,RA2,RA2/A,RD,RD/A,RH,RHE,RHE4,RHE4/A,RHQ4,RHQ4/A,RH26,RH26/A,RSC2,RSC2/A,RSS,RSS/A,RX,RX/A,RXQ4,RXQ4/A,RXU,RXU/A,SD,SD/A,SE,SE/A,SH,SH/A,SHE,SHEZ,SHQ4,SHQ4/A,SJ,SJ/A,SJG,SJG/A,SJP,SK,SK1,SMC4,SMC4/A,SMD,SME1,SME1/A,SME6,SME6/A,SMX2,SN,SN/A,SW,SWA4,SWC4,SWC4/A,SWE,SX,SX/A,SXB,SXB/A,SXB7,SXB7/A,SXE,SXE/A,SXEB,SXEB/A,SXE4,SXE4/A,SXE8,SXE8/A,SXQ4,SXQ4/A,SXU,SXU/A,SX2,VA,VAG2,VAG2/A,VAW,VAW1,VA2,VA2/A,VDE,VDE2,VDE2/A,VD16,VEB6,VH,VKB2,VKB2/A,VMA4,VME2,VME2/A,VME4,VM2,VM2/A,VNG1,VNG1/A,VNT2,VNT2/A,VN17,VN17/A,VSD,VSD/A,VSD7,VSD7/A,VSH7,VNA,VNA2,VNA2/A,VWN2,VWN2/A,VWT4,VWT4/A,VW12,VW12/A,VW22,VX,VX/A,VXB,VXB/A,VXB2,VXB6,VXB7,VXB7/A,VXE,VXEB,VXEB/A,VXE4,VXE4/A,VXE6,VXE6/A,VXE7,VXE7/A,VXG,VXQ4,VXQ4/A,VXTB,VXT1,VXT1/A,VXU,VXU/A,VX26,WMA4,WMT8,WMT8/A,WXE8,WXE8/A
10	16100-ZE2-P51 16100-ZE2-P52	CARBURETOR ASSY. (BE17B A) .. CARBURETOR ASSY. (BE17B B) ..	1 1	- -	- -	----- -----	1027933 LWD 1174062 LWD

2

Ref. No.	Part No.	Description	Reqd. QTY			Serial No.	Parts catalogue code
			(1)	GX270 (2)	(3)		
10)	16100-ZE2-P53	CARBURETOR ASSY. (BE17B C)	..	1	-	1174063	----- LWD
	16100-ZH9-W00	CARBURETOR ASSY. (BE75A A)	..	1	-	1175950	HAQ,QAQ,QSC9,QXC6,QXC9
	16100-ZH9-W01	CARBURETOR ASSY. (BE75A B)	..	1	-	-----	QSC9/A,QWA2,QWA4,QWA4/A,QWH2,QWH2/A,QXC6/A,QXC9/A,VMA4,VME4
				1	-	1175951	----- HAQ,QAQ,QSC9,QXC6,QXC9
	16100-ZH9-W20	CARBURETOR ASSY. (BE75B A)	..	1	-	1175523	HA2,HEA2,HX26,PA2,PX26,QAE2,QAE6,QAR2,QA2,QH26,QXE6,QX26,RA2,RH26 RSC2,SX2,VA2,VDE2,VWA2,VWN2,VW12,VW22,VXB2,VXB6,VX26
	16100-ZH9-W21	CARBURETOR ASSY. (BE75B B)	..	1	-	-----	HA2/A,HEA2/A,HEA8,HEA8/A,HX/A,HXQ4/A,HX26/A,HX8/A,LH/A,LHB5,LHE/A LX/A,LXE/A,LXE8/A,LXQ4/A,LXU/A,PAE2,PAE2/A,PA2/A,PX/A,PXE8,PXE8/A PXU/A,PX26/A,QAB3/A,QAE2/A,QAE6/A,QAG,QAG/A,QAG2,QAG2/A,QAQ4/A QAR2/A,QAW,QAW/A,QA2/A,QH/A,QHB5,QHE4/A,QHP1/A,QHQ4/A,QHR,QHR/A QHR4,QHR4/A,QHZ/A,QH26/A,QKE4,QL2,QME2/A,QMH/A,QSE/A,QSE2,QSE8/A QX/A,QXB/A,QXB6,QXB6/A,QXB7,QXB7/A,QXE/A,QXE4/A,QXE6/A,QXE8/A QXQ4/A,QXU/A,QX26/A,RA2/A,RHE4/A,RHQ4/A,RH26/A,RSC2/A,RSS,RSS/A RX/A,RXQ4/A,RXU/A,SH/A,SHQ4/A,SME1/A,SMX2,SWA4,SWC4/A,SX/A,SXB/A SXB7,SXB7/A,SXE/A,SXEB/A,SXE4/A,SXE8/A,SXQ4/A,SXU/A,VAG2,VAG2/A VA2/A,VDE2/A,VKB2,VKB2/A,VME2,VME2/A,VM2,VM2/A,VNG1/A,VNT2,VNT2/A VN17,VN17/A,VSD/A,VSD7,VSD7/A,VSH7,VWA2/A,VWN2/A,VW12/A,VX/A VXB/A,VXB7,VXB7/A,VXEB/A,VXE4/A,VXE6,VXE6/A,VXE7,VXE7/A,VXQ4/A VXU/A,VXU1/A
				1	-	1175524	----- HA2,HEA2,HX26,LX16,PA2,PX26,QAE2,QAE6,QAR2,QA2,QH26,QXE6,QX26,RA2 RH26,RSC2,SX2,VA2,VDE2,VD16,VEB6,VWA2,VWN2,VW12,VW22,VXB2,VXB6 VX26
				1	-	1340170	----- SWC4
				1	-	1471452	----- HX,HXQ4,HX8,LH,LHE,LX,LXE,LXE8,LXQ4,LXU,PX,PXU,QAB3,QAQ4,QH,QHE4 QHP1,QHQ4,QHZ,QME2,QMH,QSE,QSE8,QX,QXB,QXE,QXE4,QXE8,QXQ4,QXU,RH RHE4,RHQ4,RX,RXQ4,RXU,SH,SHQ4,SMD,SME1,SX,SXB,SXE,SXEB,SXE4,SXE8 SXQ4,SXU,VDE,VH,VNG1,VSD,VX,VXB,VXE,VXEB,VXE4,VXG,VXQ4,VXTB,VXU VXU1
	16100-ZH9-800	CARBURETOR ASSY. (BE24B B)	..	1	(1)	-----	1175523 QSC,Q2
				1	-	-----	1173689 QXC4
		(CYCLONE)		1	-	-----	1175033 QHC,QXC
				-	(1)	-----	1173689 L1,Q1,R1,S1,W1
	16100-ZH9-801	CARBURETOR ASSY. (BE24B C)	..	1	(1)	-----	1175524 QSC,Q2
				1	-	-----	1173690 QXC4
				1	-	-----	1175034 QHC,QXC
				1	-	-----	2301831 QXC4/A
		(CYCLONE)		-	(1)	-----	1173690 L1,Q1,R1,S1,W1
				-	(1)	-----	2301831 L1/A,Q1/A,R1/A,S1/A,W1/A
	16100-ZH9-810	CARBURETOR ASSY. (BE21B A)	..	1	-	-----	1175033 QD,RD,SD,SMC4,SN
				-	(1)	-----	Q2
		(STANDARD)		-	(1)	-----	1175034 L1,Q1,R1,S1,V1,W1
	16100-ZH9-811	CARBURETOR ASSY. (BE21B B)	..	1	-	-----	2296345 QD/A,RD/A,SD/A,SMC4/A,SN/A
				(1)	-	-----	1175034 QD,RD,SD,SMC4,SN
				(1)	-	-----	1274336 SMD
				(1)	-	-----	1445376 WMT8
		(STANDARD)		-	(1)	-----	1175035 L1,Q1,R1,S1,V1,W1
				-	(1)	-----	2296345 L1/A,Q1/A,R1/A,S1/A,W1/A
	16100-ZH9-820	CARBURETOR ASSY. (BE21A B)	..	1	-	-----	1173689 HA,HEA,HH,HX,HXQ4,LH,LHE,LHQ4,LJ,LJG,LSS,LTJ,LW,LX,LXE,LXQ4,LXZ LX16,PA,PX,QA,QAE,QAQ4,QE,QH,QHE,QHE4,QHQ4,QME2,QP,QT,QX,QXB,QXE QXEB,QXE4,QXQ4,RA,RH,RHE,RHE4,RHQ4,RX,RXQ4,SE,SH,SHE,SHEZ,SHQ4,SJ SJG,SJP,SK,SME1,SME6,SW,SWE,SX,SXB,SXE,SXEB,SXE4,SXQ4,VA,VAW,VAW1 VDE,VD16,VEB6,VNG1,VSD,VWA,VX,VXB,VXE,VXEB,VXE4,VXG,VXQ4,VXU
				1	-	-----	1175523 VH
				-	(1)	-----	Q2
		(COCK&STRAINER)		-	(1)	-----	1173689 L1,Q1,R1,S1,W1



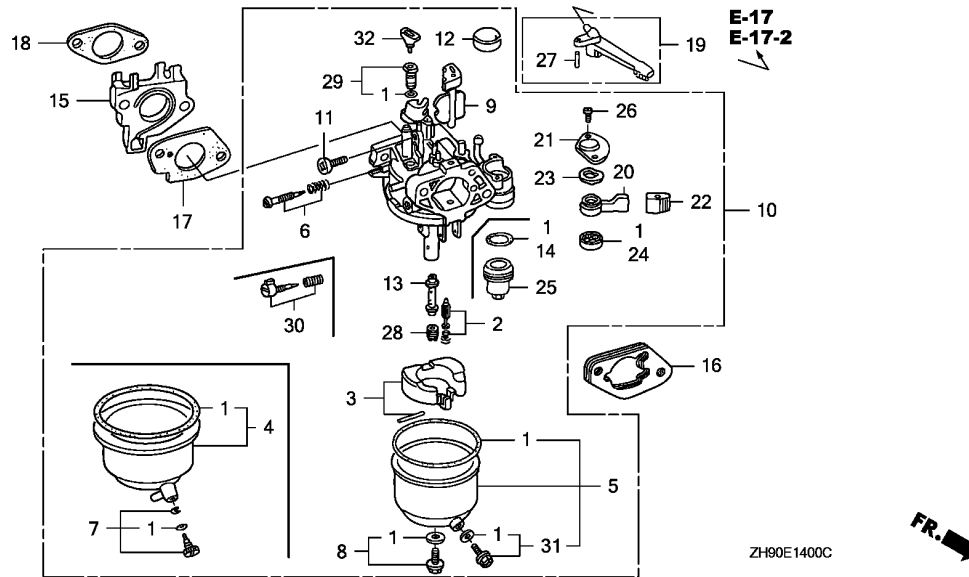

Ref. No.	Part No.	Description	Reqd. QTY			Serial No.	Parts catalogue code
			(1)	(2)	(3)		
10)	16100-ZH9-821	CARBURETOR ASSY. (BE21A C)	1	-	-	-----	ES1,LHB1,LHB3,LJC,LT,LWD1,QAB1,QKE3,SKE1,VWT4,VXT1
			1	-	-	1173690	----- HA,HEA,HH,LHQ4,LJ,LJG,LSS,LTJ,LW,LXZ,PA,QA,QAE,QE,QHE,QP,QT,QXEB
			1	-	-	1340169	----- RA,RHE,SE,SHE,SHEZ,SJ,SJG,SJP,SK,SME6,SW,SWE,VA,VAW,VAW1,VWA
			1	-	-	1471451	----- SWC4
			1	-	-	1471451	----- HX8,LXE8,LXU,PXU,QAB3,QHP1,QHZ,QMH,QSE,QSE8,QXE8,QXU,RXU,SXE8,SXU
			1	-	-	2295156	----- VXTB,VXU1
			1	-	-	1173690	----- ES1/A,LJ/A,LJC/A,LJG/A,LT/A,LW/A,LWD1/A,QA/A,QKE3/A,QP/A,QT/A
			1	-	-	1173690	----- SE/A,SJ/A,SJG/A,SME6/A,VWT4/A,VXT1/A
			1	-	-	1175523	----- LX16,VD16,VEB6
			1	-	-	1471451	----- HX,HXQ4,LH,LHE,LX,LXE,LXQ4,PX,QAQ4,QH,QHE4,QHQ4,QME2,QX,QXB,QXE
			1	-	-	1471451	----- QXE4,QXQ4,RH,RHE4,RHQ4,RX,RXQ4,SH,SHQ4,SME1,SX,SXB,SXE,SXEB,SXE4
			1	-	-	1175524	----- SXQ4,VDE,VNG1,VSD,VX,VXB,VXE,VXEB,VXE4,VXG,VXQ4,VXU
			1	-	-	1471451	----- VH
			1	-	-	1274337	----- SMD
		(COCK&STRAINER)	-	(1)	-	1173690	----- L1,Q1,R1,S1,W1
			-	(1)	-	2295156	----- L1/A,Q1/A,R1/A,S1/A,W1/A
16100-ZK9-V21	CARBURETOR ASSY. (BE76C A)	--	1	-	-	-----	WMA4,WMT8/A,WXE8,WXE8/A
			1	-	-	1445377	----- WMT8
16100-ZH9-802	CARBURETOR ASSY. (BE24B D)	--	1	-	-	2301832	----- QXC4/A
	(CYCLONE)		-	(1)	-	2301832	----- L1/A,Q1/A,R1/A,S1/A,W1/A
16100-ZH9-812	CARBURETOR ASSY. (BE21B C)	--	1	-	-	2296346	----- QD/A,RD/A,SD/A,SMC4/A,SN/A
	(STANDARD)		-	(1)	-	2296346	----- L1/A,Q1/A,R1/A,S1/A,W1/A
16100-ZH9-822	CARBURETOR ASSY. (BE21A D)	--	1	-	-	2295157	----- ES1/A,LJ/A,LJC/A,LJG/A,LT/A,LW/A,LWD1/A,QA/A,QKE3/A,QP/A,QT/A
	(COCK&STRAINER)		-	(1)	-	2295157	----- SE/A,SJ/A,SJG/A,SME6/A,VWT4/A,VXT1/A
			-	(1)	-	2295157	----- L1/A,Q1/A,R1/A,S1/A,W1/A

2

Ref. No.	Part No.	Description	Reqd. QTY			Serial No.	Parts catalogue code
			(1)	(2)	(3)		
11	16124-ZE0-005	SCREW, THROTTLE STOP	1	-	-	-----	ES1,ES1/A,HA,HAQ,HA2,HA2/A,HEA,HEA2,HEA2/A,HEA8,HEA8/A,HH,HX,HX/A,HXQ4,HXQ4/A,HX26,HX26/A,HX8,HX8/A,LH,LH/A,LHB1,LHB3,LHB5,LHE,LHE/A,LHQ4,LJ,LJ/A,LJC,LJC/A,LJG,LJG/A,LSS,LT,LT/A,LTJ,LW,LW/A,LWD,LWD1,LWD1/A,LX,LX/A,LXE,LXE/A,LXE8,LXE8/A,LXQ4,LXQ4/A,LXU,LXU/A,LXZ,LX16,PA,PAE2,PAE2/A,PA2,PA2/A,PX,PX/A,PXE8,PXE8/A,PXU,PXU/A,PX26,PX26/A,QA,QAB1,QAB3,QAB3/A,QAE,QAE2,QAE2/A,QAE6,QAE6/A,QAG,QAG/A,QAG2,QAG2/A,QAQ,QAQ4,QAQ4/A,QAR2,QAR2/A,QAW,QAW/A,QA2,QA2/A,QD,QD/A,QE,QE/A,QH,QH/A,QHB5,QHC,QHE,QHE4,QHE4/A,QHP1,QHP1/A,QHQ4,QHQ4/A,QHR,QHR/A,QHR4,QHR4/A,QHZ,QHZ/A,QH26,QH26/A,QKE3,QKE3/A,QKE4,QL2,QME2,QME2/A,QMH,QMH/A,QP,QP/A,QSC,QSC9,QSC9/A,QSE,QSE/A,QSE2,QSE8,QSE8/A,QT,QT/A,QWA2,QWA4,QWA4/A,QWH2,QWH2/A,QX,QX/A,QXB,QXB/A,QXB6,QXB6/A,QXB7,QXB7/A,QXC,QXC4,QXC4/A,QXC6,QXC6/A,QXC9,QXC9/A,QXE,QXE/A,QXEB,QXE4,QXE4/A,QXE6,QXE6/A,QXE8,QXE8/A,QXQ4,QXQ4/A,QXU,QXU/A,QX26,QX26/A,RA,RA2,RA2/A,RD,RD/A,RH,RHE,RHE4,RHE4/A,RHQ4,RHQ4/A,RH26,RH26/A,RSC2,RSC2/A,RSS,RSS/A,RX,RX/A,RXQ4,RXQ4/A,RXU,RXU/A,SD,SD/A,SE,SE/A,SH,SH/A,SHE,SHEZ,SHQ4,SHQ4/A,SJ,SJ/A,SJG,SJG/A,SJP,SK,SKE1,SMC4,SMC4/A,SMD,SME1,SME1/A,SME6,SME6/A,SMX2,SN,SN/A,SW,SWA4,SWC4,SWC4/A,SWE,SX,SX/A,SXB,SXB/A,SXB7,SXB7/A,SXE,SXE/A,SXEB,SXEB/A,SXE4,SXE4/A,SXE8,SXE8/A,SXQ4,SXQ4/A,SXU,SXU/A,SX2,VA,VAG2,VAG2/A,VAW,VAW1,VA2,VA2/A,VDE,VDE2,VDE2/A,VD16,VEB6,VH,VKB2,VKB2/A,VMA4,VME2,VME2/A,VME4,VME4/A,VNG1,VNG1/A,VNT2,VNT2/A,VN17,VN17/A,VSD,VSD/A,VSD7,VSD7/A,VSH7,VWA,VWA2,VWA2/A,VWN2,VWN2/A,VWT4,VWT4/A,VW12,VW12/A,VW22,VX,VX/A,VXB,VXB/A,VXB2,VXB6,VXB7,VXB7/A,VXE,VXEB,VXEB/A,VXE4,VXE4/A,VXE6,VXE6/A,VXE7,VXE7/A,VXG,VXQ4,VXQ4/A,VXTB,VXT1,VXT1/A,VXU,VXU/A,VXU1,VXU1/A,VX26,WMA4,WMT8,WMT8/A,WXE8,WXE8/A
12	16148-141-881	CAP, CHOKE DUST	1	(1)	-	-----	LWD
13	16166-ZH9-000	NOZZLE, MAIN	1	-	-	-----	QHC,QSC,QXC,QXC4,QXC4/A
	16166-ZH9-820	1	(1)	-	-----	ES1,ES1/A,HA,HEA,HH,LHB1,LHB3,LHQ4,LJ,LJ/A,LJC,LJC/A,LJG,LJG/A,LSS,LT,LT/A,LTJ,LW,LW/A,LWD1,LWD1/A,LXZ,PA,QA,QAB1,QAE,QD,QD/A,QE,QA,QHE,QKE3,QKE3/A,QP,QP/A,QT,QT/A,QXEB,RA,RD,RD/A,RHE,SD,SD/A,SE,SE/A,SHE,SHEZ,SJ,SJ/A,SJG,SJG/A,SJP,SK,SKE1,SMC4,SMC4/A,SME6,SME6/A,SN,SN/A,SW,SWE,VA,VAW,VAW1,VWA,VWT4,VWT4/A,VXT1,VXT1/A
		(CARBURETOR NO.)	1	-	-	-----	BE21A C HX,HXQ4,HX8,LH,LHE,LX,LXE,LXE8,LXQ4,LXU,LX16,PX,PXU,QAB3,QAQ4,QH,QHE4,QHP1,QHQ4,QHZ,QME2,QMH,QSE,QSE8,QX,QXB,QXE,QXE4,QXE8,QXQ4,QXU,RH,RHE4,RHQ4,RX,RXQ4,RXU,SH,SHQ4,SMD,SME1,SWC4,SX,SXB,SXE,SXEB,SXE4,SXE8,SXQ4,SXU,VDE,VD16,VEB6,VH,VNG1,VSD,VX,VXB,VXE,VXEB,VXE4,VXG,VXQ4,VXTB,VXU,VXU1
		//	1	-	-	-----	BE21B B WMT8
			1	(1)	-	-----	LWD
	16166-ZE2-781	1	-	-	-----	HAQ,QAQ,QSC9,QSC9/A,QWA2,QWA4,QWA4/A,QWH2,QWH2/A,QXC6,QXC6/A,QXC9,QXC9/A,VMA4,VME4
	16166-ZH9-W00	1	-	-	-----	



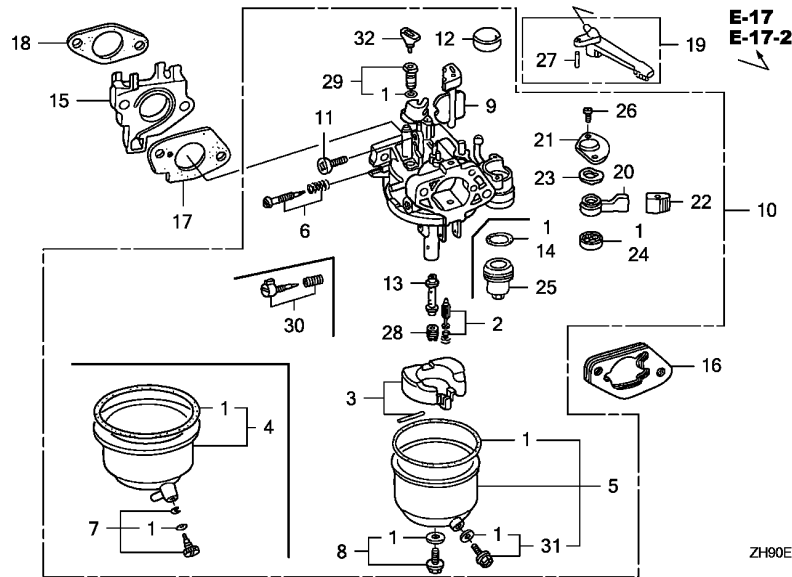

2

Ref. No.	Part No.	Description	Reqd. QTY			Serial No.	Parts catalogue code
			(1)	(2)	(3)		
13)	16166-ZH9-W20	NOZZLE, MAIN	1	-	-	HA2,HA2/A,HEA2,HEA2/A,HEA8,HEA8/A,HX/A,HXQ4/A,HX26,HX26/A,HX8/A,LH/A,LHB5,LHE/A,LX/A,LXE/A,LXE8/A,LXQ4/A,LXU/A,PAE2,PAE2/A,PA2,PA2/A,PX/A,PXE8,PXE8/A,PXU/A,PX26,PX26/A,QAB3/A,QAE2,QAE2/A,QAE6,QAE6/A,QAG,QAG/A,QAG2,QAG2/A,QAQ4/A,QAR2,QAR2/A,QAW,QAW/A,QA2,QA2/A,QH/A,QHB5,QHE4/A,QHP1/A,QHQ4/A,QHR,QHR/A,QHR4,QHR4/A,QHZ/A,QH26,QH26/A,QKE4,QL2,QME2/A,QMH/A,QSE/A,QSE2,QSE8/A,QX/A,QXB/A,QXB6,QXB6/A,QXB7,QXB7/A,QXE/A,QXE4/A,QXE6,QXE6/A,QXE8/A,QXQ4/A,QXU/A,QX26,QX26/A,RA2,RA2/A,RHE4/A,RHQ4/A,RH26,RH26/A,RSC2,RSC2/A,RSS,RSS/A,RX/A,RXQ4/A,RXU/A,SH/A,SHQ4/A,SME1/A,SMX2,SWA4,SWC4/A,SX/A,SXB/A,SXB7,SXB7/A,SXE/A,SXEB/A,SXE4/A,SXE8/A,SXQ4/A,SXU/A,SX2,VAG2,VAG2/A,VA2,VA2/A,VDE2,VDE2/A,VKB2,VKB2/A,VME2,VME2/A,VM2,VM2/A,VNG1/A,VNT2,VNT2/A,VN17,VN17/A,VSD/A,VSD7,VSD7/A,VSH7,VWA2,VWA2/A,VWN2,VWN2/A,VW12,VW12/A,VW22,VX/A,VXB/A,VXB2,VXB6,VXB7,VXB7/A,VXEB/A,VXE4/A,VXE6,VXE6/A,VXE7,VXE7/A,VXQ4/A,VXU/A,VXU1/A,VX26,WMA4,WMT8/A,WXE8,WXE8/A	
		(CARBURETOR NO.)	1	-	-	BE75B B	HX,HXQ4,HX8,LH,LHE,LX,LXE,LXE8,LXQ4,LXU,LX16,PX,PXU,QAB3,QAQ4,QH,QHE4,QHP1,QHQ4,QHZ,QME2,QMH,QSE,QSE8,QX,QXB,QXE,QXE4,QXE8,QXQ4,QXU,RH,RHE4,RHQ4,RX,RXQ4,RXU,SH,SHQ4,SMD,SME1,SWC4,SX,SXB,SXE,SXEB,SXE4,SXE8,SXQ4,SXU,VDE,VD16,VEB6,VH,VNG1,VSD,VX,VXB,VXE,VXEB,VXE4,VXG,VXQ4,VXTB,VXU,VXU1
		..	1	-	-	BE76C A	WMT8

Ref. No.	Part No.	Description	Reqd. QTY			Serial No.	Parts catalogue code
			(1)	(2)	(3)		
14	16173-001-004	PACKING, FUEL STRAINER CUP ..	1	-	-	-----	ES1,ES1/A,HA,HAQ,HA2,HA2/A,HEA,HEA2,HEA2/A,HEA8,HEA8/A,HH,HX,HX/A,HXQ4,HXQ4/A,HX26,HX26/A,HX8,HX8/A,LH,LH/A,LHB1,LHB3,LHB5,LHE,LHE/A,LHQ4,LJ,LJ/A,LJC,LJC/A,LJG,LJG/A,LSS,LT,LT/A,LTJ,LW,LW/A,LWD,LWD1,LWD1/A,LX,LX/A,LXE,LXE/A,LXE8,LXE8/A,LXQ4,LXQ4/A,LXU,LXU/A,LXZ,LX16,PA,PAE2,PAE2/A,PA2,PA2/A,PX,PX/A,PXE8,PXE8/A,PXU,PXU/A,PX26,PX26/A,QA,QAB1,QAB3,QAB3/A,QAE,QAE2,QAE2/A,QAE6,QAE6/A,QAG,QAG/A,QAG2,QAG2/A,QAQ,QAQ4,QAQ4/A,QAR2,QAR2/A,QAW,QAW/A,QA2,QA2/A,QE,QE/A,QH,QH/A,QHB5,QHC,QHE,QHE4,QHE4/A,QHP1,QHP1/A,QHQ4,QHQ4/A,QHR,QHR/A,QHR4,QHR4/A,QHZ,QHZ/A,QH26,QH26/A,QKE3,QKE3/A,QKE4,QL2,QME2,QME2/A,QMH,QMH/A,QP,QP/A,QSC,QSC9,QSC9/A,QSE/A,QSE2,QSE8,QSE8/A,QT,QT/A,QWA2,QWA4,QWA4/A,QWH2,QWH2/A,QX,QX/A,QXB,QXB/A,QXB6,QXB6/A,QXB7,QXB7/A,QXC,QXC4,QXC4/A,QXC6,QXC6/A,QXC9,QXC9/A,QXE,QXE/A,QXEB,QXE4,QXE4/A,QXE6,QXE6/A,QXE8,QXE8/A,QXQ4,QXQ4/A,QXU,QXU/A,QX26,QX26/A,RA,RA2,RA2/A,RH,RHE,RHE4,RHE4/A,RHQ4,RHQ4/A,RH26,RH26/A,RSC2,RSC2/A,RSS,RSS/A,RX,RX/A,RXQ4,RXQ4/A,RXU,RXU/A,SE,SE/A,SH,SH/A,SHE,SHE2,SHQ4,SHQ4/A,SJ,SJ/A,SJG,SJG/A,SJP,SK,SKE1,SME1,SME1/A,SME6,SME6/A,SMX2,SW,SWA4,SWC4,SWC4/A,SWE,SX,SX/A,SXB,SXB/A,SXB7,SXB7/A,SXE,SXE/A,SXEB,SXEB/A,SXE4,SXE4/A,SXE8,SXE8/A,SXQ4,SXQ4/A,SXU,SXU/A,SX2,VA,VAG2,VAG2/A,VAW,VAW1,VA2,VA2/A,VDE,VDE2,VDE2/A,VD16,VEB6,VH,VKB2,VKB2/A,VMA4,VME2,VME2/A,VME4,VM2,VM2/A,VNG1,VNG1/A,VNT2,VNT2/A,VN17,VN17/A,VSD,VSD/A,VSD7,VSD7/A,VSH7,VWA,VWA2,VWA2/A,VWN2,VWN2/A,VWT4,VWT4/A,VW12,VW12/A,VW22,VX,VX/A,VXB,VXB/A,VXB2,VXB6,VXB7,VXB7/A,VXE,VXEB,VXEB/A,VXE4,VXE4/A,VXE6,VXE6/A,VXE7,VXE7/A,VXG,VXQ4,VXQ4/A,VXTB,VXT1,VXT1/A,VXU,VXU/A,VXU1,VXU1/A,VX26
		(CARBURETOR NO.)	1	-	-	BE21A C -----	SMD
15	16211-ZE2-000	INSULATOR, CARBURETOR	1	-	-	-----	ES1,ES1/A,HA,HAQ,HA2,HA2/A,HEA,HEA2,HEA2/A,HEA8,HEA8/A,HH,HX,HX/A,HXQ4,HXQ4/A,HX26,HX26/A,HX8,HX8/A,LH,LH/A,LHB1,LHB3,LHB5,LHE,LHE/A,LHQ4,LJ,LJ/A,LJC,LJC/A,LJG,LJG/A,LSS,LT,LT/A,LTJ,LW,LW/A,LWD,LWD1,LWD1/A,LX,LX/A,LXE,LXE/A,LXE8,LXE8/A,LXQ4,LXQ4/A,LXU,LXU/A,LXZ,LX16,PA,PAE2,PAE2/A,PA2,PA2/A,PX,PX/A,PXE8,PXE8/A,PXU,PXU/A,PX26,PX26/A,QA,QAB1,QAB3,QAB3/A,QAE,QAE2,QAE2/A,QAE6,QAE6/A,QAG,QAG/A,QAG2,QAG2/A,QAQ,QAQ4,QAQ4/A,QAR2,QAR2/A,QAW,QAW/A,QA2,QA2/A,QD,QD/A,QE,QE/A,QH,QH/A,QHB5,QHC,QHE,QHE4,QHE4/A,QHP1,QHP1/A,QHQ4,QHQ4/A,QHR,QHR/A,QHR4,QHR4/A,QHZ,QHZ/A,QH26,QH26/A,QKE3,QKE3/A,QL2,QME2,QME2/A,QMH,QMH/A,QP,QP/A,QSC,QSC9,QSC9/A,QSE/A,QSE2,QSE8,QSE8/A,QT,QT/A,QWA2,QWA4,QWA4/A,QWH2,QWH2/A,QX,QX/A,QXB,QXB/A,QXB6,QXB6/A,QXB7,QXB7/A,QXC,QXC4,QXC4/A,QXC6,QXC6/A,QXC9,QXC9/A,QXE,QXE/A,QXEB,QXE4,QXE4/A,QXE6,QXE6/A,QXE8,QXE8/A,QXQ4,QXQ4/A,QXU,QXU/A,QX26,QX26/A,RA,RA2,RA2/A,RD,RD/A,RH,RHE,RHE4,RHE4/A,RHQ4,RHQ4/A,RH26,RH26/A,RSC2,RSC2/A,RSS,RSS/A,RX,RX/A,RXQ4,RXQ4/A,RXU,RXU/A,SD,SD/A,SE,SE/A,SH,SH/A,SHE,SHE2,SHQ4,SHQ4/A,SJ,SJ/A,SJG,SJG/A,SJP,SK,SKE1,SMC4,SMC4/A,SMD,SME1,SME1/A,SME6,SME6/A,SMX2,SN,SN/A,SW,SWA4,SWC4,SWC4/A,SWE,SX,SX/A,SXB,SXB/A,SXB7,SXB7/A,SXE,SXE/A,SXEB,SXEB/A,SXE4,SXE4/A,SXE8,SXE8/A,SXQ4,SXQ4/A,SXU,SXU/A,SX2,VA,VAG2,VAG2/A,VAW,VAW1,VA2,VA2/A,VDE,VDE2,VDE2/A,VD16,VEB6,VH,VKB2,VKB2/A,VMA4,VME2,VME2/A,VME4,VM2,VM2/A,VNG1,VNG1/A,VNT2,VNT2/A,VN17,VN17/A,VSD,VSD/A,VSD7,VSD7/A,VSH7,VWA,VWA2,VWA2/A,VWN2,VWN2/A,VWT4,VWT4/A,VW12,VW12/A,VW22,VX,VX/A,VXB,VXB/A,VXB2,VXB6,VXB7,VXB7/A,VXE,VXEB,VXEB/A,VXE4,VXE4/A,VXE6,VXE6/A,VXE7,VXE7/A,VXG,VXQ4,VXQ4/A,VXTB,VXT1,VXT1/A,VXU,VXU/A,VXU1,VXU1/A,VX26,WMA4,WMT8,WMT8/A,WXE8,WXE8/A



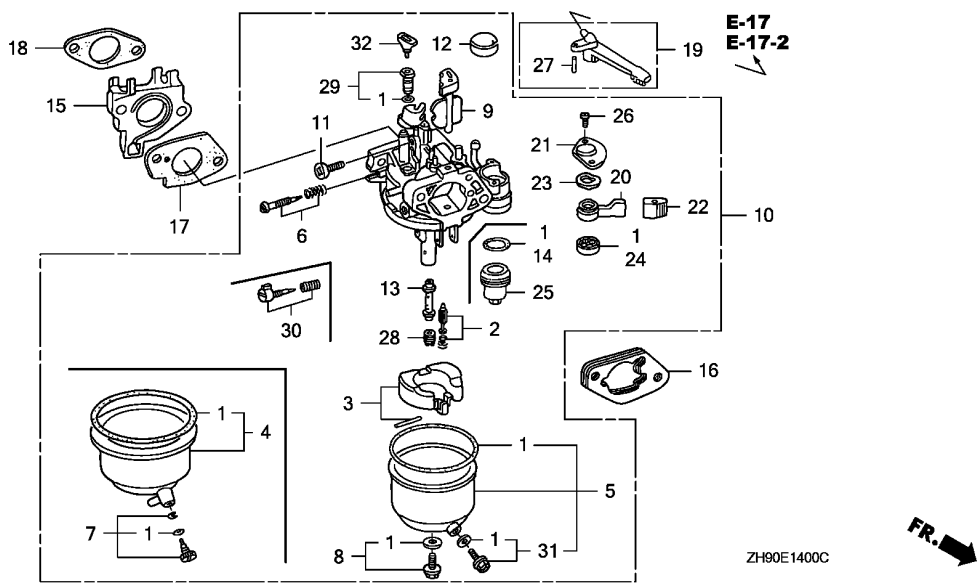

Ref. No.	Part No.	Description	Reqd. QTY			Serial No.	Parts catalogue code
			(1)	(2)	(3)		
16	16220-ZA0-702	SPACER COMP., CARBURETOR	1	-	-	-----	ES1,ES1/A,HA,HAQ,HA2,HA2/A,HEA,HEA2,HEA2/A,HEA8,HEA8/A,HH,HX,HX/A,HXQ4,HXQ4/A,HX26,HX26/A,HX8,HX8/A,LH,LH/A,LHB1,LHB3,LHB5,LHE,LHE/A,LHQ4,LJ,LJ/A,LJC,LJC/A,LJG,LJG/A,LSS,LT,LT/A,LW,LW/A,LWD,LX,LX/A,LXE,LXE/A,LXE8,LXE8/A,LXQ4,LXQ4/A,LXU,LXU/A,LXZ,LX16,PA,PAE2,PAE2/A,PA2,PA2/A,PX,PX/A,PXE8,PXE8/A,PXU,PXU/A,PX26,PX26/A,QA,QAB1,QAB3,QAB3/A,QAE,QAE2,QAE2/A,QAE6,QAE6/A,QAG,QAG/A,QAG2,QAG2/A,QAQ,QAQ4,QAQ4/A,QAR2,QAR2/A,QAW,QAW/A,QA2,QA2/A,QD,QD/A,QE,QE/A,QH,QH/A,QHB5,QHC,QHE,QHE4,QHE4/A,QHP1,QHP1/A,QHQ4,QHQ4/A,QHR,QHR/A,QHR4,QHR4/A,QHZ,QHZ/A,QH26,QH26/A,QL2,QMH,QMH/A,QP,QP/A,QSC,QSC9,QSC9/A,QSE,QSE/A,QSE2,QSE8,QSE8/A,QT,QT/A,QWA2,QWA4,QWA4/A,QWH2,QWH2/A,QX,QX/A,QXB,QXB/A,QXB6,QXB6/A,QXB7,QXB7/A,QXC,QXC4,QXC4/A,QXC6,QXC6/A,QXC9,QXC9/A,QXE,QXE/A,QXEB,QXE4,QXE4/A,QXE6,QXE6/A,QXE8,QXE8/A,QXQ4,QXQ4/A,QXU,QXU/A,QX26,QX26/A,RA,RA2,RA2/A,RD,RD/A,RH,RHE,RHE4,RHE4/A,RHQ4,RHQ4/A,RH26,RH26/A,RSC2,RSC2/A,RSS,RSS/A,RX,RX/A,RXQ4,RXQ4/A,RXU,RXU/A,SD,SD/A,SE,SE/A,SH,SH/A,SHE,SHEZ,SHQ4,SHQ4/A,SJ,SJ/A,SJG,SJG/A,SJP,SK,SMC4,SMC4/A,SMD,SME1,SME1/A,SME6,SME6/A,SMX2,SN,SN/A,SW,SWA4,SWC4,SWC4/A,SWE,SX,SX/A,SXB,SXB/A,SXB7,SXB7/A,SXE,SXE/A,SXEB,SXEB/A,SXE4,SXE4/A,SXE8,SXE8/A,SXQ4,SXQ4/A,SXU,SXU/A,SX2,VA,VAG2,VAG2/A,VAV,VAV1,VA2,VA2/A,VDE,VDE2,VDE2/A,VD16,VEB6,VH,VKB2,VKB2/A,VMA4,VME2,VME2/A,VME4,VM2,VM2/A,VNG1,VNG1/A,VNT2,VNT2/A,VN17,VN17/A,VSD,VSD/A,VSD7,VSD7/A,VSH7,VWA,VWA2,VWA2/A,VWN2,VWN2/A,VWT4,VWT4/A,VW12,VW12/A,VW22,VX,VX/A,VXB,VXB/A,VXB2,VXB6,VXB7,VXB7/A,VXE,VXEB,VXEB/A,VXE4,VXE4/A,VXE6,VXE6/A,VXE7,VXE7/A,VXG,VXQ4,VXQ4/A,VXTB,VXT1,VXT1/A,VXU,VXU/A,VXU1,VXU1/A,VX26,WMA4,WMT8,WMT8/A,WXE8,WXE8/A
17	16221-ZA0-700	PACKING, CARBURETOR	1	(1)	-	-----	1047495 LJ,LW,LXZ,L1,Q1,R1,SHEZ,SJ,SJP,SK,SW,SWE,S1,V1,W1
			-	(1)	-	-----	Q2

2

Ref. No.	Part No.	Description	Reqd. QTY			Serial No.	Parts catalogue code
			(1)	(2)	(3)		
17)	16221-ZA0-800	PACKING, CARBURETOR	1	(1)	-	-----	ES1, ES1/A, HA, HAQ, HA2, HA2/A, HEA, HEA2, HEA2/A, HEA8, HEA8/A, HH, HX, HX/A, HXQ4, HXQ4/A, HX26, HX26/A, HX8, HX8/A, LH, LH/A, LHB1, LHB3, LHB5, LHE, LHE/A, LHQ4, LJ/A, LJC, LJC/A, LJG, LJG/A, LSS, LT, LT/A, LTJ, LW/A, LWD, LWD1, LWD1/A, LX, LX/A, LXE, LXE/A, LXE8, LXE8/A, LXQ4, LXQ4/A, LXU, LXU/A, LX16, LX16/A, PA, PAE2, PAE2/A, PA2, PA2/A, PX, PX/A, PXE8, PXE8/A, PXU, PXU/A, PX26, PX26/A, QA, QAB1, QAB3, QAB3/A, QAE, QAE2, QAE2/A, QAE6, QAE6/A, QAG, QAG/A, QAG2, QAG2/A, QAQ, QAQ4, QAQ4/A, QAR2, QAR2/A, QAW, QAW/A, QA2, QA2/A, QD, QD/A, QE, QE/A, QH, QH/A, QHB5, QHC, QHE, QHE4, QHE4/A, QHP1, QHP1/A, QHQ4, QHQ4/A, QHR, QHR/A, QHR4, QHR4/A, QHZ, QHZ/A, QH26, QH26/A, QKE3, QKE3/A, QKE4, QL2, QME2, QME2/A, QMH, QMH/A, QP, QP/A, QSC, QSC9, QSC9/A, QSE, QSE/A, QSE2, QSE8, QSE8/A, QT, QT/A, QWA2, QWA4, QWA4/A, QWH2, QWH2/A, QX, QX/A, QXB, QXB/A, QXB6, QXB6/A, QXB7, QXB7/A, QXC, QXC4, QXC4/A, QXC6, QXC6/A, QXC9, QXC9/A, QXE, QXE/A, QXEB, QXE4, QXE4/A, QXE6, QXE6/A, QXE8, QXE8/A, QXQ4, QXQ4/A, QXU, QXU/A, QX26, QX26/A, Q1/A, Q2, RA, RA2, RA2/A, RD, RD/A, RH, RHE, RHE4, RHE4/A, RHQ4, RHQ4/A, RH26, RH26/A, RSC2, RSC2/A, RSS, RSS/A, RX, RX/A, RXQ4, RXQ4/A, RXU, RXU/A, R1/A, SD, SD/A, SE, SE/A, SH, SH/A, SHE, SHQ4, SHQ4/A, SJ/A, SJG, SJG/A, SKE1, SMC4, SMC4/A, SMD, SME1, SME1/A, SME6, SME6/A, SMX2, SN, SN/A, SWA4, SWC4, SWC4/A, SX, SX/A, SXB, SXB/A, SXB7, SXB7/A, SXE, SXE/A, SXEB, SXEB/A, SXE4, SXE4/A, SXE8, SXE8/A, SXQ4, SXQ4/A, SXU, SXU/A, SX2, S1/A, VA, VAG2, VAG2/A, VAW, VAW1, VA2, VA2/A, VDE, VDE2, VDE2/A, VD16, VEB6, VH, VKB2, VKB2/A, VMA4, VME2, VME2/A, VME4, VM2, VM2/A, VNG1, VNG1/A, VNT2, VNT2/A, VN17, VN17/A, VSD, VSD/A, VSD7, VSD7/A, VSH7, VWA, VWA2, VWA2/A, VWN2, VWN2/A, VWT4, VWT4/A, VW12, VW12/A, VW22, VX, VX/A, VXB, VXB/A, VXB2, VXB6, VXB7, VXB7/A, VXE, VXE8, VXE8/A, VXE4, VXE4/A, VXE6, VXE6/A, VXE7, VXE7/A, VXG, VXQ4, VXQ4/A, VXTB, VXT1, VXT1/A, VXU, VXU/A, VXU1, VXU1/A, VX26, WMA4, WMT8, WMT8/A, WXE8, WXE8/A, W1/A
18	16223-ZA0-700	PACKING, INSULATOR	1	(1)	-	1047496	LJ, LW, LXZ, L1, Q1, R1, SHEZ, SJ, SJP, SK, SW, SWE, S1, V1, W1
	16223-ZA0-800	1	(1)	-	-----	ES1, ES1/A, HA, HAQ, HA2, HA2/A, HEA, HEA2, HEA2/A, HEA8, HEA8/A, HH, HX, HX/A, HXQ4, HXQ4/A, HX26, HX26/A, HX8, HX8/A, LH, LH/A, LHB1, LHB3, LHB5, LHE, LHE/A, LHQ4, LJ/A, LJC, LJC/A, LJG, LJG/A, LSS, LT, LT/A, LTJ, LW/A, LWD, LWD1, LWD1/A, LX, LX/A, LXE, LXE/A, LXE8, LXE8/A, LXQ4, LXQ4/A, LXU, LXU/A, LX16, LX16/A, PA, PAE2, PAE2/A, PA2, PA2/A, PX, PX/A, PXE8, PXE8/A, PXU, PXU/A, PX26, PX26/A, QA, QAB1, QAB3, QAB3/A, QAE, QAE2, QAE2/A, QAE6, QAE6/A, QAG, QAG/A, QAG2, QAG2/A, QAQ, QAQ4, QAQ4/A, QAR2, QAR2/A, QAW, QAW/A, QA2, QA2/A, QD, QD/A, QE, QE/A, QH, QH/A, QHB5, QHC, QHE, QHE4, QHE4/A, QHP1, QHP1/A, QHQ4, QHQ4/A, QHR, QHR/A, QHR4, QHR4/A, QHZ, QHZ/A, QH26, QH26/A, QKE3, QKE3/A, QKE4, QL2, QME2, QME2/A, QMH, QMH/A, QP, QP/A, QSC, QSC9, QSC9/A, QSE, QSE/A, QSE2, QSE8, QSE8/A, QT, QT/A, QWA2, QWA4, QWA4/A, QWH2, QWH2/A, QX, QX/A, QXB, QXB/A, QXB6, QXB6/A, QXB7, QXB7/A, QXC, QXC4, QXC4/A, QXC6, QXC6/A, QXC9, QXC9/A, QXE, QXE/A, QXEB, QXE4, QXE4/A, QXE6, QXE6/A, QXE8, QXE8/A, QXQ4, QXQ4/A, QXU, QXU/A, QX26, QX26/A, Q1/A, Q2, RA, RA2, RA2/A, RD, RD/A, RH, RHE, RHE4, RHE4/A, RHQ4, RHQ4/A, RH26, RH26/A, RSC2, RSC2/A, RSS, RSS/A, RX, RX/A, RXQ4, RXQ4/A, RXU, RXU/A, R1/A, SD, SD/A, SE, SE/A, SH, SH/A, SHE, SHQ4, SHQ4/A, SJ/A, SJG, SJG/A, SKE1, SMC4, SMC4/A, SMD, SME1, SME1/A, SME6, SME6/A, SMX2, SN, SN/A, SWA4, SWC4, SWC4/A, SX, SX/A, SXB, SXB/A, SXB7, SXB7/A, SXE, SXE/A, SXEB, SXEB/A, SXE4, SXE4/A, SXE8, SXE8/A, SXQ4, SXQ4/A, SXU, SXU/A, SX2, S1/A, VA, VAG2, VAG2/A, VAW, VAW1, VA2, VA2/A, VDE, VDE2, VDE2/A, VD16, VEB6, VH, VKB2, VKB2/A, VMA4, VME2, VME2/A, VME4, VM2, VM2/A, VNG1, VNG1/A, VNT2, VNT2/A, VN17, VN17/A, VSD, VSD/A, VSD7, VSD7/A, VSH7, VWA, VWA2, VWA2/A, VWN2, VWN2/A, VWT4, VWT4/A, VW12, VW12/A, VW22, VX, VX/A, VXB, VXB/A, VXB2, VXB6, VXB7, VXB7/A, VXE, VXE8, VXE8/A, VXE4, VXE4/A, VXE6, VXE6/A, VXE7, VXE7/A, VXG, VXQ4, VXQ4/A, VXTB, VXT1, VXT1/A, VXU, VXU/A, VXU1, VXU1/A, VX26, WMA4, WMT8, WMT8/A, WXE8, WXE8/A, W1/A
			1	(1)	-	1047496	LJ, LW, LXZ, L1, Q1, R1, SHEZ, SJ, SJP, SK, SW, SWE, S1, V1, W1



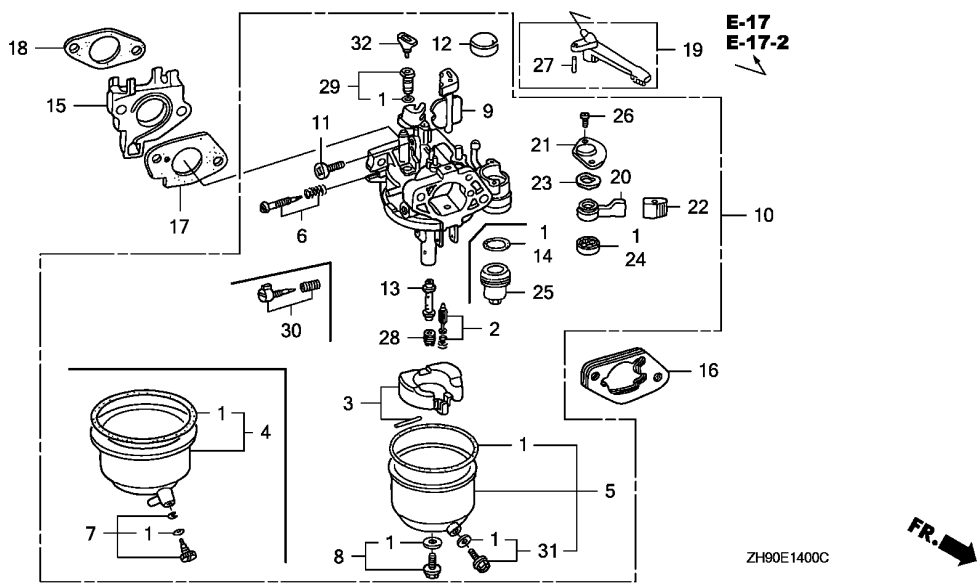

2

Ref. No.	Part No.	Description	Reqd. QTY			Serial No.	Parts catalogue code
			(1)	(2)	(3)		
19	16610-ZE1-000	LEVER COMP., CHOKE (STD.) ...	1	-	-	-----	ES1,ES1/A,HA,HAQ,HA2,HA2/A,HEA,HEA2,HEA2/A,HEA8,HEA8/A,HH,HX,HX/A,HXQ4,HXQ4/A,HX26,HX26/A,HX8,HX8/A,LH,LH/A,LHB1,LHB3,LHB5,LHE,LHE/A,LHQ4,LJ,LJ/A,LJC,LJC/A,LJG,LJG/A,LSS,LT,LT/A,LW,LW/A,LX,LX/A,LXE,LXE/A,LXE8,LXE8/A,LXQ4,LXQ4/A,LXU,LXU/A,LXZ,LX16,PA,PAE2,PAE2/A,PA2,PA2/A,PX,PX/A,PXE8,PXE8/A,PXU,PXU/A,PX26,PX26/A,QA,QAB1,QAB3,QAB3/A,QAE,QAE2,QAE2/A,QAE6,QAE6/A,QAG,QAG/A,QAG2,QAG2/A,QAQ,QAQ4,QAQ4/A,QAR2,QAR2/A,QAW,QAW/A,QA2,QA2/A,QD,QD/A,QE,QE/A,QH,QH/A,QHB5,QHC,QHE,QHE4,QHE4/A,QHP1,QHP1/A,QHQ4,QHQ4/A,QHR,QHR/A,QHR4,QHR4/A,QHZ,QHZ/A,QH26,QH26/A,QL2,QMH,QMH/A,QP,QP/A,QSC,QSC9,QSC9/A,QSE,QSE/A,QSE2,QSE8,QSE8/A,QT,QT/A,QWA2,QWA4,QWA4/A,QWH2,QWH2/A,QX,QX/A,QXB,QXB/A,QXB6,QXB6/A,QXB7,QXB7/A,QXC,QXC4,QXC4/A,QXC6,QXC6/A,QXC9,QXC9/A,QXE,QXE/A,QXEB,QXE4,QXE4/A,QXE6,QXE6/A,QXE8,QXE8/A,QXQ4,QXQ4/A,QXU,QXU/A,QX26,QX26/A,RA,RA2,RA2/A,RD,RD/A,RH,RHE,RHE4,RHE4/A,RHQ4,RHQ4/A,RH26,RH26/A,RSC2,RSC2/A,RSS,RSS/A,RX,RX/A,RXQ4,RXQ4/A,RXU,RXU/A,SD,SD/A,SE,SE/A,SH,SH/A,SHE,SHEZ,SHQ4,SHQ4/A,SJ,SJ/A,SJG,SJG/A,SJP,SK,SMC4,SMC4/A,SMD,SME1,SME1/A,SME6,SME6/A,SMX2,SN,SN/A,SW,SWA4,SWC4,SWC4/A,SWE,SX,SX/A,SXB,SXB/A,SXB7,SXB7/A,SXE,SXE/A,SXEB,SXEB/A,SXE4,SXE4/A,SXE8,SXE8/A,SXQ4,SXQ4/A,SXU,SXU/A,SX2,VA,VAG2,VAG2/A,VAV,VAV1,VA2,VA2/A,VDE,VDE2,VDE2/A,VD16,VEB6,VH,VKB2,VKB2/A,VMA4,VME2,VME2/A,VME4,VM2,VM2/A,VNG1,VNG1/A,VNT2,VNT2/A,VN17,VN17/A,VSD,VSD/A,VSD7,VSD7/A,VSH7,VVA,VVA2,VVA2/A,VWN2,VWN2/A,VWT4,VWT4/A,VW12,VW12/A,VW22,VX,VX/A,VXB,VXB/A,VXB2,VXB6,VXB7,VXB7/A,VXE,VXEB,VXEB/A,VXE4,VXE4/A,VXE6,VXE6/A,VXE7,VXE7/A,VXG,VXQ4,VXQ4/A,VXTB,VXT1,VXT1/A,VXU,VXU/A,VXU1,VXU1/A,VX26,WMA4,WMT8,WMT8/A,WXE8,WXE8/A
			-	(1)	-		

Ref. No.	Part No.	Description	Reqd. QTY			Serial No.	Parts catalogue code
			(1)	(2)	(3)		
20	16953-ZE1-811	LEVER, COCK (CARBURETOR NO.) // // // //	1	(1)	-	BE24B B	L1,QHC,QSC,QXC,QXC4,Q1,R1,S1,V1,W1
			1	-	-	BE21A B	HA,HEA,HH,HX,HXQ4,LH,LHE,LHQ4,LW,LX,LXE,LXQ4,LXZ,LX16,PA,PX,QA,QAE,QAQ4,QE,QH,QHE,QHE4,QHQ4,QME2,QP,QT,QX,QXB,QXE,QXEB,QXE4,QXQ4,RA,RH,RHE,RHE4,RHQ4,RX,RXQ4,SE,SH,SHE,SHEZ,SHQ4,SME1,SME6,SW,SWE,SX,SXB,SXE,SXEB,SXE4,SXQ4,VA,VAW,VAW1,VDE,VD16,VEB6,VH,VNG1,VSD,VWA,VX,VXB,VXE,VXEB,VXE4,VXG,VXQ4,VXU
			1	-	-	BE21B A	QD,RD,SD,SMC4,SN
			1	-	-	BE23A B	LJ,LJG,LSS,LTJ,SJ,SJG,SJP,SK
			1	-	-	BE75A A	HAQ,QAQ,QSC9,QXC6,QXC9
			1	-	-	BE75B A	HA2,HEA2,HX26,PA2,PX26,QAE2,QAE6,QAR2,QA2,QH26,QXE6,QX26,RA2,RH26,RSC2, SX2,VA2,VDE2,VWA2,VWN2,VW12,VW22,VXB2,VXB6,VX26
	16953-ZE1-812 (CARBURETOR NO.) // // // //	1	(1)	-	-----	Q2
			1	(1)	-	-----	ES1,ES1/A,HA2/A,HEA2/A,HEA8,HEA8/A,HX/A,HXQ4/A,HX26/A,HX8,HX8/A,LH/A,LHB1,LHB3,LHB5,LHE/A,LJ/A,LJC,LJC/A,LJG/A,LT,LT/A,LW/A,LWD1,LWD1/A,LX/A,LXE/A,LXE8,LXE8/A,LXQ4/A,LXU,LXU/A,L1/A,PAE2,PAE2/A,PA2/A,PX/A,PXE8,PXE8/A,PXU,PXU/A,PX26/A,QAB1,QAB3,QAB3/A,QAE2/A,QAE6/A,QAG,QAG/A,QAG2,QAG2/A,QAQ4/A,QAR2/A,QAW,QAW/A,QA2/A,QD/A,QE/A,QH/A,QHB5,QHE4/A,QHP1,QHP1/A,QHQ4/A,QHR,QHR/A,QHR4,QHR4/A,QHZ,QHZ/A,QH26/A,QKE3,QKE3/A,QKE4,QL2,QME2/A,QMH,QMH/A,QP/A,QSC9/A,QSE,QSE/A,QSE2,QSE8,QSE8/A,QT/A,QWA2,QWA4,QWA4/A,QWH2,QWH2/A,QX/A,QXB/A,QXB6,QXB6/A,QXB7,QXB7/A,QXC4/A,QXC6/A,QXC9/A,QXE/A,QXE4/A,QXE6/A,QXE8,QXE8/A,QXQ4/A,QXU,QXU/A,QX26/A,Q1/A,RA2/A,RD/A,RHE4/A,RHQ4/A,RH26/A,RSC2/A,RSS,RSS/A,RX/A,RXQ4/A,RXU,RXU/A,R1/A,SD/A,SE/A,SH/A,SHQ4/A,SJ/A,SJG/A,SKE1,SMC4/A,SMD,SME1/A,SME6/A,SMX2,SN/A,SWA4,SWC4,SWC4/A,SX/A,SXB/A,SXB7,SXB7/A,SXE/A,SXEB/A,SXE4/A,SXE8,SXE8/A,SXQ4/A,SXU,SXU/A,S1/A,VAG2,VAG2/A,VA2/A,VDE2/A,VKB2,VKB2/A,VMA4,VME2,VME2/A,VME4,VM2,VM2/A,VNG1/A,VNT2,VNT2/A,VN17,VN17/A,VSD/A,VSD7,VSD7/A,VSH7,VWA2/A,VWN2/A,VWT4,VWT4/A,VW12/A,VX/A,VXB/A,VXB7,VXB7/A,VXEB/A,VXE4/A,VXE6,VXE6/A,VXE7,VXE7/A,VXQ4/A,VXTB,VXT1,VXT1/A,VXU/A,VXU1,VXU1/A,WMA4,WMT8,WMT8/A,WXE8,WXE8/A,W1/A
			1	(1)	-	BE24B C	L1,QHC,QSC,QXC,QXC4,Q1,Q2,R1,S1,V1,W1
			1	-	-	BE21A C	HA,HEA,HH,HX,HXQ4,LH,LHE,LHQ4,LW,LX,LXE,LXQ4,LXZ,LX16,PA,PX,QA,QAE,QAQ4,QE,QH,QHE,QHE4,QHQ4,QME2,QP,QT,QX,QXB,QXE,QXEB,QXE4,QXQ4,RA,RH,RHE,RHE4,RHQ4,RX,RXQ4,SE,SH,SHE,SHEZ,SHQ4,SME1,SME6,SW,SWE,SX,SXB,SXE,SXEB,SXE4,SXQ4,VA,VAW,VAW1,VDE,VD16,VEB6,VH,VNG1,VSD,VWA,VX,VXB,VXE,VXEB,VXE4,VXG,VXQ4,VXU
			1	-	-	BE21B B	QD,RD,SD,SMC4,SN
			1	-	-	BE23A C	LJ,LJG,LSS,LTJ,SJ,SJG,SJP,SK
			1	-	-	BE75A B	HAQ,QAQ,QSC9,QXC6,QXC9
			1	-	-	BE75B B	HA2,HEA2,HX26,PA2,PX26,QAE2,QAE6,QAR2,QA2,QH26,QXE6,QX26,RA2,RH26,RSC2, SX2,VA2,VDE2,VWA2,VWN2,VW12,VW22,VXB2,VXB6,VX26
	16953-ZE1-711 (CARBURETOR NO.)	1	-	-	BE17B B	LWD
	16953-ZE1-712 (CARBURETOR NO.)	1	-	-	BE17B C	LWD



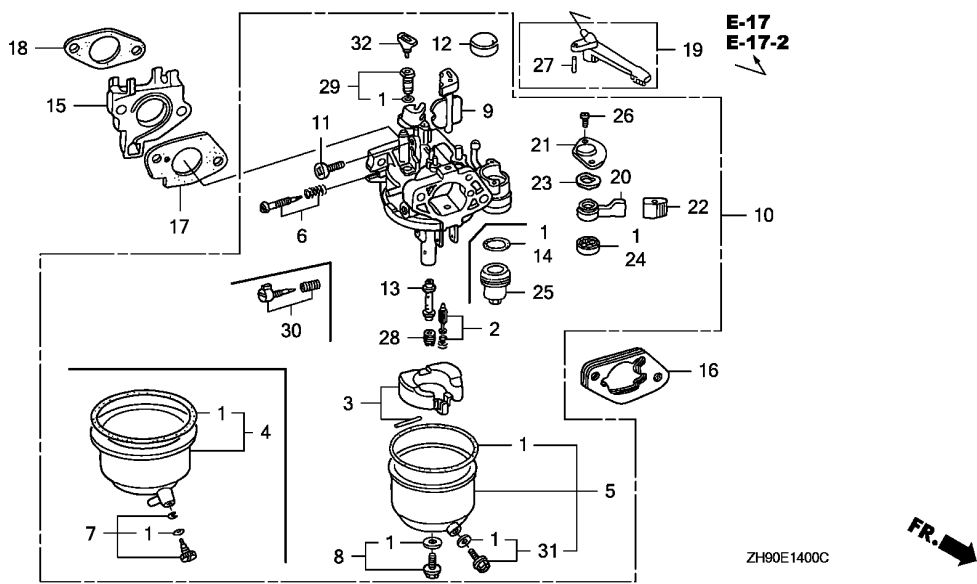

Ref. No.	Part No.	Description	Reqd. QTY			Serial No.	Parts catalogue code
			(1)	(2)	(3)		
21	16954-ZE1-812	PLATE, LEVER SETTING	1	-	-	-----	ES1, ES1/A, HA, HAQ, HA2, HA2/A, HEA, HEA2, HEA2/A, HEA8, HEA8/A, HH, HX, HX/A, HXQ4, HXQ4/A, HX26, HX26/A, HX8, HX8/A, LH, LH/A, LHB1, LHB3, LHB5, LHE, LHE/A, LHQ4, LJ, LJ/A, LJC, LJC/A, LJG, LJG/A, LSS, LT, LT/A, LTJ, LW, LW/A, LWD, LWD1, LWD1/A, LX, LX/A, LXE, LXE/A, LXE8, LXE8/A, LXQ4, LXQ4/A, LXU, LXU/A, LXZ, LX16, PA, PAE2, PAE2/A, PA2, PA2/A, PX, PX/A, PXE8, PXE8/A, PXU, PXU/A, PX26, PX26/A, QA, QAB1, QAB3, QAB3/A, QAE, QAE2, QAE2/A, QAE6, QAE6/A, QAG, QAG/A, QAG2, QAG2/A, QAQ, QAQ4, QAQ4/A, QAR2, QAR2/A, QAW, QAW/A, QA2, QA2/A, QD, QD/A, QE, QE/A, QH, QH/A, QHB5, QHC, QHE, QHE4, QHE4/A, QHP1, QHP1/A, QHQ4, QHQ4/A, QHR, QHR/A, QHR4, QHR4/A, QHZ, QHZ/A, QH26, QH26/A, QKE3, QKE3/A, QKE4, QL2, QME2, QME2/A, QMH, QMH/A, QP, QP/A, QSC, QSC9, QSC9/A, QSE, QSE/A, QSE2, QSE8, QSE8/A, QT, QT/A, QWA2, QWA4, QWA4/A, QWH2, QWH2/A, QX, QX/A, QXB, QXB/A, QXB6, QXB6/A, QXB7, QXB7/A, QXC, QXC4, QXC4/A, QXC6, QXC6/A, QXC9, QXC9/A, QXE, QXE/A, QXEB, QXE4, QXE4/A, QXE6, QXE6/A, QXE8, QXE8/A, QXQ4, QXQ4/A, QXU, QXU/A, QX26, QX26/A, RA, RA2, RA2/A, RD, RD/A, RH, RHE, RHE4, RHE4/A, RHQ4, RHQ4/A, RH26, RH26/A, RSC2, RSC2/A, RSS, RSS/A, RX, RX/A, RXQ4, RXQ4/A, RXU, RXU/A, SD, SD/A, SE, SE/A, SH, SH/A, SHE, SHEZ, SHQ4, SHQ4/A, SJ, SJ/A, SJG, SJG/A, SJP, SK, SKE1, SMC4, SMC4/A, SMD, SME1, SME1/A, SME6, SME6/A, SMX2, SN, SN/A, SW, SWA4, SWC4, SWC4/A, SWE, SX, SX/A, SXB, SXB/A, SXB7, SXB7/A, SXE, SXE/A, SXEB, SXEB/A, SXE4, SXE4/A, SXE8, SXE8/A, SXQ4, SXQ4/A, SXU, SXU/A, SX2, VA, VAG2, VAG2/A, VAW, VAW1, VA2, VA2/A, VDE, VDE2, VDE2/A, VD16, VEB6, VH, VKB2, VKB2/A, VMA4, VME2, VME2/A, VME4, VM2, VM2/A, VNG1, VNG1/A, VNT2, VNT2/A, VN17, VN17/A, VSD, VSD/A, VSD7, VSD7/A, VSH7, VWA, VWA2, VWA2/A, VWN2, VWN2/A, VWT4, VWT4/A, VW12, VW12/A, VW22, VX, VX/A, VXB, VXB/A, VXB2, VXB6, VXB7, VXB7/A, VXE, VXEB, VXEB/A, VXE4, VXE4/A, VXE6, VXE6/A, VXE7, VXE7/A, VXC, VXQ4, VXQ4/A, VXTB, VXT1, VXT1/A, VXU, VXU/A, VXU1, VXU1/A, VX26, WMA4, WMT8, WMT8/A, WXE8, WXE8/A
22	16955-ZE2-H21	CAP, LEVER	1	(1)	-	-----	LWD

2

Ref. No.	Part No.	Description	Reqd. QTY			Serial No.	Parts catalogue code
			(1)	(2)	(3)		
23	16956-ZE1-811	SPRING, COCK LEVER	1	-	-	-----	ES1,ES1/A,HA,HAQ,HA2,HA2/A,HEA,HEA2,HEA2/A,HEA8,HEA8/A,HH,HX,HX/A HXQ4,HXQ4/A,HX26,HX26/A,HX8,HX8/A,LH,LH/A,LHB1,LHB3,LHB5,LHE LHE/A,LHQ4,LJ,LJ/A,LJC,LJC/A,LJG,LJG/A,LSS,LT,LT/A,LTJ,LW,LW/A LWD,LWD1,LWD1/A,LX,LX/A,LXE,LXE/A,LXE8,LXE8/A,LXQ4,LXQ4/A,LXU LXU/A,LXZ,LX16,PA,PAE2,PAE2/A,PA2,PA2/A,PX,PX/A,PXE8,PXE8/A,PXU PXU/A,PX26,PX26/A,QA,QAB1,QAB3,QAB3/A,QAQ,QAQ2,QAQ2/A,QAQ,QAQ4,QAQ4/A,QAR2,QAR2/A,QAW,QAW/A,QA2 QA2/A,QD,QD/A,QE,QE/A,QH,QH/A,QHB5,QHC,QHE,QHE4,QHE4/A,QHP1 QHP1/A,QHQ4,QHQ4/A,QHR,QHR/A,QHR4,QHR4/A,QHZ,QHZ/A,QH26,QH26/A QKE3,QKE3/A,QKE4,QL2,QME2,QME2/A,QMH,QMH/A,QP,QP/A,QSC,QSC9 QSC9/A,QSE,QSE/A,QSE2,QSE8,QSE8/A,QT,QT/A,QWA2,QWA4,QWA4/A,QWH2 QWH2/A,QX,QX/A,QXB,QXB/A,QXB6,QXB6/A,QXB7,QXB7/A,QXC,QXC4,QXC4/A QXC6,QXC6/A,QXC9,QXC9/A,QXE,QXE/A,QXEB,QXE4,QXE6,QXE6/A QXE8,QXE8/A,QXQ4,QXQ4/A,QXU,QXU/A,QX26,QX26/A,RA,RA2,RA2/A,RD RD/A,RH,RHE,RHE4,RHE4/A,RHQ4,RHQ4/A,RH26,RH26/A,RSC2,RSC2/A,RSS RSS/A,RX,RX/A,RXQ4,RXQ4/A,RXU,RXU/A,SD,SD/A,SE,SE/A,SH,SH/A,SHE SHEZ,SHQ4,SHQ4/A,SJ,SJ/A,SJG,SJG/A,SJP,SK,SKE1,SMC4,SMC4/A,SMD SME1,SME1/A,SME6,SME6/A,SMX2,SN,SN/A,SW,SWA4,SWC4,SWC4/A,SWE,SX SX/A,SXB,SXB/A,SXB7,SXB7/A,SXE,SXE/A,SXEB,SXEB/A,SXE4,SXE4/A,SXE8 SXE8/A,SXQ4,SXQ4/A,SXU,SXU/A,SX2,VA,VAG2,VAG2/A,VAW,VAW1,VA2 VA2/A,VDE,VDE2,VDE2/A,VD16,VEB6,VH,VKB2,VKB2/A,VMA4,VME2,VME2/A VME4,VM2,VM2/A,VNG1,VNG1/A,VNT2,VNT2/A,VN17,VN17/A,VSD,VSD/A,VSD7 VSD7/A,VSH7,VWA,VWA2,VWA2/A,VWN2,VWN2/A,VWT4,VWT4/A,VW12,VW12/A VW22,VX,VX/A,VXB,VXB/A,VXB2,VXB6,VXB7,VXB7/A,VXE,VXEB,VXEB/A,VXE4 VXE4/A,VXE6,VXE6/A,VXE7,VXE7/A,VXG,VXQ4,VXQ4/A,VXTB,VXT1,VXT1/A VXU,VXU/A,VXU1,VXU1/A,VX26,WMA4,WMT8,WMT8/A,WXE8,WXE8/A
			-	(1)	-		
24	16957-ZE1-812	PACKING, FUEL COCK	1	-	-	-----	ES1,ES1/A,HA,HAQ,HA2,HA2/A,HEA,HEA2,HEA2/A,HEA8,HEA8/A,HH,HX,HX/A HXQ4,HXQ4/A,HX26,HX26/A,HX8,HX8/A,LH,LH/A,LHB1,LHB3,LHB5,LHE LHE/A,LHQ4,LJ,LJ/A,LJC,LJC/A,LJG,LJG/A,LSS,LT,LT/A,LTJ,LW,LW/A LWD,LWD1,LWD1/A,LX,LX/A,LXE,LXE/A,LXE8,LXE8/A,LXQ4,LXQ4/A,LXU LXU/A,LXZ,LX16,PA,PAE2,PAE2/A,PA2,PA2/A,PX,PX/A,PXE8,PXE8/A,PXU PXU/A,PX26,PX26/A,QA,QAB1,QAB3,QAB3/A,QAQ,QAQ2,QAQ2/A,QAQ,QAQ4,QAQ4/A,QAR2,QAR2/A,QAW,QAW/A,QA2 QA2/A,QD,QD/A,QE,QE/A,QH,QH/A,QHB5,QHC,QHE,QHE4,QHE4/A,QHP1 QHP1/A,QHQ4,QHQ4/A,QHR,QHR/A,QHR4,QHR4/A,QHZ,QHZ/A,QH26,QH26/A QKE3,QKE3/A,QKE4,QL2,QME2,QME2/A,QMH,QMH/A,QP,QP/A,QSC,QSC9 QSC9/A,QSE,QSE/A,QSE2,QSE8,QSE8/A,QT,QT/A,QWA2,QWA4,QWA4/A,QWH2 QWH2/A,QX,QX/A,QXB,QXB/A,QXB6,QXB6/A,QXB7,QXB7/A,QXC,QXC4,QXC4/A QXC6,QXC6/A,QXC9,QXC9/A,QXE,QXE/A,QXEB,QXE4,QXE6,QXE6/A QXE8,QXE8/A,QXQ4,QXQ4/A,QXU,QXU/A,QX26,QX26/A,RA,RA2,RA2/A,RD RD/A,RH,RHE,RHE4,RHE4/A,RHQ4,RHQ4/A,RH26,RH26/A,RSC2,RSC2/A,RSS RSS/A,RX,RX/A,RXQ4,RXQ4/A,RXU,RXU/A,SD,SD/A,SE,SE/A,SH,SH/A,SHE SHEZ,SHQ4,SHQ4/A,SJ,SJ/A,SJG,SJG/A,SJP,SK,SKE1,SMC4,SMC4/A,SMD SME1,SME1/A,SME6,SME6/A,SMX2,SN,SN/A,SW,SWA4,SWC4,SWC4/A,SWE,SX SX/A,SXB,SXB/A,SXB7,SXB7/A,SXE,SXE/A,SXEB,SXEB/A,SXE4,SXE4/A,SXE8 SXE8/A,SXQ4,SXQ4/A,SXU,SXU/A,SX2,VA,VAG2,VAG2/A,VAW,VAW1,VA2 VA2/A,VDE,VDE2,VDE2/A,VD16,VEB6,VH,VKB2,VKB2/A,VMA4,VME2,VME2/A VME4,VM2,VM2/A,VNG1,VNG1/A,VNT2,VNT2/A,VN17,VN17/A,VSD,VSD/A,VSD7 VSD7/A,VSH7,VWA,VWA2,VWA2/A,VWN2,VWN2/A,VWT4,VWT4/A,VW12,VW12/A VW22,VX,VX/A,VXB,VXB/A,VXB2,VXB6,VXB7,VXB7/A,VXE,VXEB,VXEB/A,VXE4 VXE4/A,VXE6,VXE6/A,VXE7,VXE7/A,VXG,VXQ4,VXQ4/A,VXTB,VXT1,VXT1/A VXU,VXU/A,VXU1,VXU1/A,VX26,WMA4,WMT8,WMT8/A,WXE8,WXE8/A
			-	(1)	-		



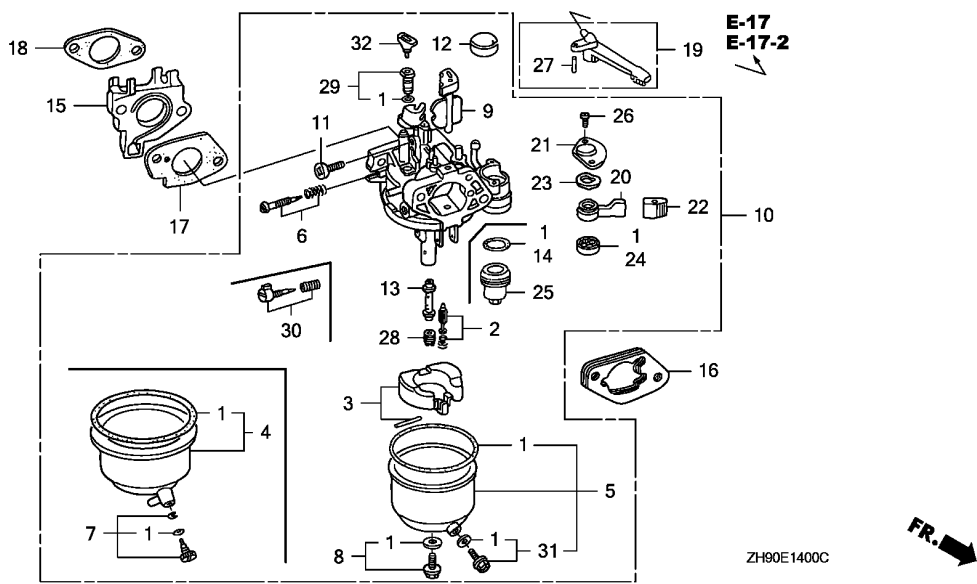

2

Ref. No.	Part No.	Description	Reqd. QTY			Serial No.	Parts catalogue code	
			(1)	(2)	(3)			
25	16967-ZE0-811	CUP, FUEL STRAINER	1	-	-	ES1,ES1/A,HA,HAQ,HA2,HA2/A,HEA,HEA2,HEA2/A,HEA8,HEA8/A,HH,HX,HX/A,HXQ4,HXQ4/A,HX26,HX26/A,HX8,HX8/A,LH,LH/A,LHB1,LHB3,LHB5,LHE,LHE/A,LHQ4,LJ,LJ/A,LJC,LJC/A,LJG,LJG/A,LSS,LT,LT/A,LTJ,LW,LW/A,LWD,LWD1,LWD1/A,LX,LX/A,LXE,LXE/A,LXE8,LXE8/A,LXQ4,LXQ4/A,LXU,LXU/A,LXZ,LX16,PA,PAE2,PAE2/A,PA2,PA2/A,PX,PX/A,PXE8,PXE8/A,PXU,PXU/A,PX26,PX26/A,QA,QAB1,QAB3,QAB3/A,QAE,QAE2,QAE2/A,QAE6,QAE6/A,QAG,QAG/A,QAG2,QAG2/A,QAQ,QAQ4,QAQ4/A,QAR2,QAR2/A,QAW,QAW/A,QA2,QA2/A,QE,QE/A,QH,QH/A,QHB5,QHC,QHE,QHE4,QHE4/A,QHP1,QHP1/A,QHQ4,QHQ4/A,QHR,QHR/A,QHR4,QHR4/A,QHZ,QHZ/A,QH26,QH26/A,QKE3,QKE3/A,QKE4,QL2,QME2,QME2/A,QMH,QMH/A,QP,QP/A,QSC,QSC9,QSC9/A,QSE,QSE/A,QSE2,QSE8,QSE8/A,QT,QT/A,QWA2,QWA4,QWA4/A,QWH2,QWH2/A,QX,QX/A,QXB,QXB/A,QXB6,QXB6/A,QXB7,QXB7/A,QXC,QXC4,QXC4/A,QXC6,QXC6/A,QXC9,QXC9/A,QXE,QXE/A,QXEB,QXE4,QXE4/A,QXE6,QXE6/A,QXE8,QXE8/A,QXQ4,QXQ4/A,QXU,QXU/A,QX26,QX26/A,RA,RA2,RA2/A,RH,RHE,RHE4,RHE4/A,RHQ4,RHQ4/A,RH26,RH26/A,RSC2,RSC2/A,RSS,RSS/A,RX,RX/A,RXQ4,RXQ4/A,RXU,RXU/A,SE,SE/A,SH,SH/A,SHE,SHE2,SHQ4,SHQ4/A,SJ,SJ/A,SJG,SJG/A,SJP,SK,SKE1,SME1,SME1/A,SME6,SME6/A,SMX2,SW,SWA4,SWC4,SWC4/A,SWE,SX,SX/A,SXB,SXB/A,SXB7,SXB7/A,SXE,SXE/A,SXEB,SXEB/A,SXE4,SXE4/A,SXE8,SXE8/A,SXQ4,SXQ4/A,SXU,SXU/A,SX2,VA,VAG2,VAG2/A,VAW,VAW1,VA2,VA2/A,VDE,VDE2,VDE2/A,VD16,VEB6,VH,VKB2,VKB2/A,VMA4,VME2,VME2/A,VME4,VM2,VM2/A,VNG1,VNG1/A,VNT2,VNT2/A,VN17,VN17/A,VSD,VSD/A,VSD7,VSD7/A,VSH7,VWA,VWA2,VWA2/A,VWN2,VWN2/A,VWT4,VWT4/A,VW12,VW12/A,VW22,VX,VX/A,VXB,VXB/A,VXB2,VXB6,VXB7,VXB7/A,VXE,VXEB,VXEB/A,VXE4,VXE4/A,VXE6,VXE6/A,VXE7,VXE7/A,VXG,VXQ4,VXQ4/A,VXTB,VXT1,VXT1/A,VXU,VXU/A,VXU1,VXU1/A,VX26		
	(CARBURETOR NO.)		1	-	-	BE21A C -----	SMD	
			-	(1)	-			

Ref. No.	Part No.	Description	Reqd. QTY			Serial No.	Parts catalogue code
			(1)	(2)	(3)		
26	93500-03008-1G	SCREW, PAN, 3X8 (CARBURETOR NO.)	2	(2)	-	BE24B B	L1,QHC,QSC,QXC,QXC4,Q1,Q2,R1,S1,W1
		//	2	-	-	BE17B B	LWD
		//	2	-	-	BE21A B	HA,HEA,HH,HX,HXQ4,LH,LHE,LHQ4,LJ,LJG,LSS,LTJ,LW,LX,LXE,LXQ4,LXZ LX16,PA,PX,QA,QAE,QAQ4,QE,QH,QHE,QHE4,QHQ4,QME2,QP,QT,QX,QXB,QXE QXEB,QXE4,QXQ4,RA,RH,RHE,RHE4,RHQ4,RX,RXQ4,SE,SH,SHE,SHEZ,SHQ4,SJ SJG,SJP,SK,SME1,SME6,SW,SWE,SX,SB,SXE,SXEB,SXE4, SXQ4,VA,VAW,VAW1 VDE,VD16,VEB6,VH,VNG1,VSD,VWA,VX,VXB,VXE,VXEB,VXE4,VXG,VXQ4,VXU
		//	2	-	-	BE21B A	QD,RD,SD,SMC4,SN
		//	2	-	-	BE75A A	HAQ,QAQ,QSC9,QXC6,QXC9
		//	2	-	-	BE75B A	HA2,HEA2,HX26,PA2,PX26,QAE2,QAE6,QAR2,QA2,QH26,QXE6,QX26,RA2,RH26 RSC2, SX2,VA2,VDE2,VWA2,VWN2,VW12,VW22,VXB2,VXB6,VX26
	93500-03006-1H	SCREW, PAN, 3X6 (CARBURETOR NO.)	2	(2)	-	-----	ES1,ES1/A,HA2/A,HEA2/A,HEA8,HEA8/A,HA/A,HXQ4/A,HX26/A,HX8,HX8/A LH/A,LHB1,LHB3,LHB5,LHE/A,LJ/A,LJC,LJC/A,LJG/A,LT,LT/A,LW/A,LWD1 LWD1/A,LX/A,LXE/A,LXE8,LXE8/A,LXQ4/A,LXU,LXU/A,L1/A,PAE2,PAE2/A PA2/A,PX/A,PXE8,PXE8/A,PXU,PXU/A,PX26/A,QAB1,QAB3,QAB3/A,QAE2/A QAE6/A,QAG,QAG/A,QAG2,QAG2/A,QAQ4/A,QAR2/A,QAW,QAW/A,QA2/A,QD/A QE/A,QH/A,QHB5,QHE4/A,QHP1,QHP1/A,QHQ4/A,QHR,QHR/A,QHR4,QHR4/A QHZ,QHZ/A,QH26/A,QKE3,QKE3/A,QKE4,QL2,QME2/A,QMH,QMH/A,QP/A QSC9/A,QSE,QSE/A,QSE2,QSE8,QSE8/A,QT/A,QWA2,QWA4,QWA4/A,QWH2 QWH2/A,QX/A,QXB/A,QXB6,QXB6/A,QXB7,QXB7/A,QXC4/A,QXC6/A,QXC9/A QXE/A,QXE4/A,QXE6/A,QXE8,QXE8/A,QXQ4/A,QXU,QXU/A,QX26/A,Q1/A RA2/A,RD/A,RHE4/A,RHQ4/A,RH26/A,RSC2/A,RSS,RSS/A,RX/A,RXQ4/A,RXU RXU/A,R1/A,SD/A,SE/A,SH/A,SHQ4/A,SJ/A,SJG/A,SKE1,SMC4/A,SMD SME1/A,SME6/A,SMX2,SN/A,SWA4,SWC4,SWC4/A,SX/A,SXB/A,SXB7,SXB7/A SXE/A,SXEB/A,SXE4/A,SXE8,SXE8/A,SXQ4/A,SXU,SXU/A,S1/A,VAG2,VAG2/A VA2/A,VDE2/A,VKB2,VKB2/A,VMA4,VME2,VME2/A,VME4,VM2,VM2/A,VNG1/A VNT2,VNT2/A,VN17,VN17/A,VSD/A,VSD7,VSD7/A,VSH7,VWA2/A,VWN2/A,VWT4 VWT4/A,VW12/A,VX/A,VXB/A,VXB7,VXB7/A,VXEB/A,VXE4/A,VXE6,VXE6/A VXE7,VXE7/A,VXQ4/A,VXTB,VXT1,VXT1/A,VXU/A,VXU1,VXU1/A,WMA4,WMT8 WMT8/A,WXE8,WXE8/A,W1/A
		//	2	(2)	-	BE24B C	L1,QHC,QSC,QXC,QXC4,Q1,Q2,R1,S1,V1,W1
		//	2	-	-	BE17B C	LWD
		//	2	-	-	BE21A C	HA,HEA,HH,HX,HXQ4,LH,LHE,LHQ4,LJ,LJG,LSS,LTJ,LW,LX,LXE,LXQ4,LXZ LX16,PA,PX,QA,QAE,QAQ4,QE,QH,QHE,QHE4,QHQ4,QME2,QP,QT,QX,QXB,QXE QXEB,QXE4,QXQ4,RA,RH,RHE,RHE4,RHQ4,RX,RXQ4,SE,SH,SHE,SHEZ,SHQ4,SJ SJG,SJP,SK,SME1,SME6,SW,SWE,SX,SB,SXE,SXEB,SXE4, SXQ4,VA,VAW,VAW1 VDE,VD16,VEB6,VH,VNG1,VSD,VWA,VX,VXB,VXE,VXEB,VXE4,VXG,VXQ4,VXU
		//	2	-	-	BE21B B	QD,RD,SD,SMC4,SN
		//	2	-	-	BE75A B	HAQ,QAQ,QSC9,QXC6,QXC9
		//	2	-	-	BE75B B	HA2,HEA2,HX26,PA2,PX26,QAE2,QAE6,QAR2,QA2,QH26,QXE6,QX26,RA2,RH26 RSC2, SX2,VA2,VDE2,VWA2,VWN2,VW12,VW22,VXB2,VXB6,VX26



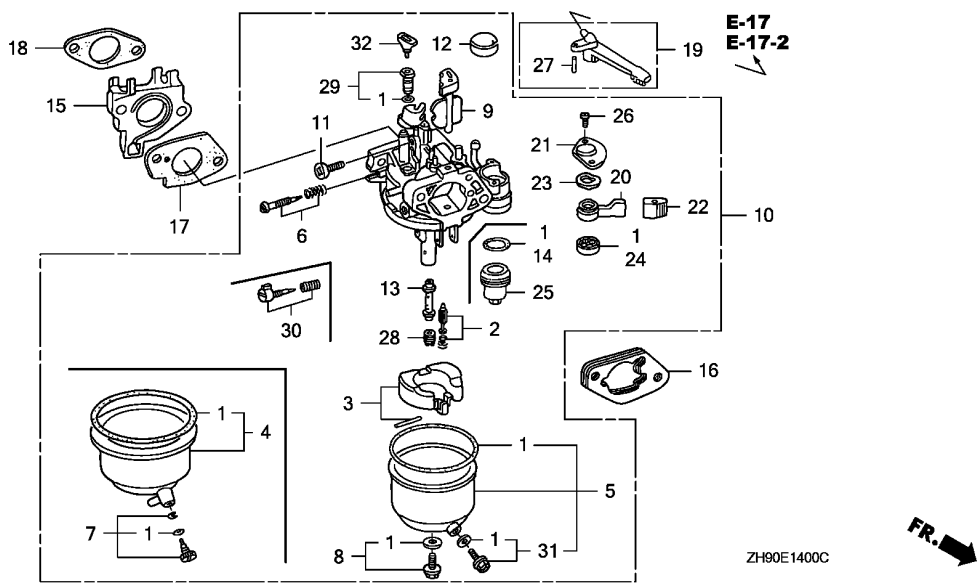

2

Ref. No.	Part No.	Description	Reqd. QTY			Serial No.	Parts catalogue code
			(1)	(2)	(3)		
27	94305-20122	PIN, SPRING, 2X12	1	-	-	-----	ES1,ES1/A,HA,HAQ,HA2,HA2/A,HEA,HEA2,HEA2/A,HEA8,HEA8/A,HH,HX,HX/A,HXQ4,HXQ4/A,HX26,HX26/A,HX8,HX8/A,LH,LH/A,LHB1,LHB3,LHB5,LHE,LHE/A,LHQ4,LJ,LJ/A,LJC,LJC/A,LJG,LJG/A,LSS,LT,LT/A,LW,LW/A,LX,LX/A,LXE,LXE/A,LXE8,LXE8/A,LXQ4,LXQ4/A,LXU,LXU/A,LXZ,LX16,PA,PAE2,PAE2/A,PA2,PA2/A,PX,PX/A,PXE8,PXE8/A,PXU,PXU/A,PX26,PX26/A,QA,QAB1,QAB3,QAB3/A,QAE,QAE2,QAE2/A,QAE6,QAE6/A,QAG,QAG/A,QAG2,QAG2/A,QAQ,QAQ4,QAQ4/A,QAR2,QAR2/A,QAW,QAW/A,QA2,QA2/A,QD,QD/A,QE,QE/A,QH,QH/A,QHB5,QHC,QHE,QHE4,QHE4/A,QHP1,QHP1/A,QHQ4,QHQ4/A,QHR,QHR/A,QHR4,QHR4/A,QHZ,QHZ/A,QH26,QH26/A,QL2,QMH,QMH/A,QP,QP/A,QSC,QSC9,QSC9/A,QSE,QSE/A,QSE2,QSE8,QSE8/A,QT,QT/A,QWA2,QWA4,QWA4/A,QWH2,QWH2/A,QX,QX/A,QXB,QXB/A,QXB6,QXB6/A,QXB7,QXB7/A,QXC,QXC4,QXC4/A,QXC6,QXC6/A,QXC9,QXC9/A,QXE,QXE/A,QXEB,QXE4,QXE4/A,QXE6,QXE6/A,QXE8,QXE8/A,QXQ4,QXQ4/A,QXU,QXU/A,QX26,QX26/A,RA,RA2,RA2/A,RD,RD/A,RH,RHE,RHE4,RHE4/A,RHQ4,RHQ4/A,RH26,RH26/A,RSC2,RSC2/A,RSS,RSS/A,RX,RX/A,RXQ4,RXQ4/A,RXU,RXU/A,SD,SD/A,SE,SE/A,SH,SH/A,SHE,SHEZ,SHQ4,SHQ4/A,SJ,SJ/A,SJG,SJG/A,SJP,SK,SMC4,SMC4/A,SMD,SME1,SME1/A,SME6,SME6/A,SMX2,SN,SN/A,SW,SWA4,SWC4,SWC4/A,SWE,SX,SX/A,SXB,SXB/A,SXB7,SXB7/A,SXE,SXE/A,SXEB,SXEB/A,SXE4,SXE4/A,SXE8,SXE8/A,SXQ4,SXQ4/A,SXU,SXU/A,SX2,VA,VAG2,VAG2/A,VAV,VAV1,VA2,VA2/A,VDE,VDE2,VDE2/A,VD16,VEB6,VH,VKB2,VKB2/A,VMA4,VME2,VME2/A,VME4,VM2,VM2/A,VNG1,VNG1/A,VNT2,VNT2/A,VN17,VN17/A,VSD,VSD/A,VSD7,VSD7/A,VSH7,VVA,VVA2,VVA2/A,VWN2,VWN2/A,VWT4,VWT4/A,VW12,VW12/A,VW22,VX,VX/A,VXB,VXB/A,VXB2,VXB6,VXB7,VXB7/A,VXE,VXEB,VXEB/A,VXE4,VXE4/A,VXE6,VXE6/A,VXE7,VXE7/A,VXG,VXQ4,VXQ4/A,VXTB,VXT1,VXT1/A,VXU,VXU/A,VXU1,VXU1/A,VX26,WMA4,WMT8,WMT8/A,WXE8,WXE8/A
			-	(1)	-		

Ref. No.	Part No.	Description	Reqd. QTY			Serial No.	Parts catalogue code
			(1)	(2)	(3)		
28	99101-ZF5-0820	JET, MAIN, #82 (CARBURETOR NO.)	(1)	(1)	-	BE21A	B HH, HX, HXQ4, LH, LHE, LHQ4, LW, LX, LXE, LXQ4, LXZ, LX16, L1, PX, QA, QAE, QAQ4, QE, QH, QHE, QHE4, QHQ4, QME2, QP, QT, QX, QXB, QXE, QXEB, QXE4, QXQ4, Q1, RH, RHE, RHE4, RHQ4, RX, RXQ4, R1, SE, SH, SHE, SHEZ, SHQ4, SME1, SME6, SW, SWE, SX, SXB, SXE, SXEB, SXE4, SXQ4, VD16, VEB6, VH, VNG1, VSD, VX, VXB, VXE, VXEB, VXE4, VXG, VXQ4, VXU, V1, W1
	99101-ZF5-0850	JET, MAIN, #85 (CARBURETOR NO.)	(1)	(1)	-	BE21A	B HH, HX, HXQ4, LH, LHE, LHQ4, LW, LX, LXE, LXQ4, LXZ, LX16, L1, PX, QA, QAE, QAQ4, QE, QH, QHE, QHE4, QHQ4, QME2, QP, QT, QX, QXB, QXE, QXEB, QXE4, QXQ4, Q1, RH, RHE, RHE4, RHQ4, RX, RXQ4, R1, SE, SH, SHE, SHEZ, SHQ4, SME1, SME6, SW, SWE, SX, SXB, SXE, SXEB, SXE4, SXQ4, VD16, VEB6, VH, VNG1, VSD, VX, VXB, VXE, VXEB, VXE4, VXG, VXQ4, VXU, V1, W1
	99101-ZF5-0880	JET, MAIN, #88 (CARBURETOR NO.)	1	1	-	BE21A	B HH, HX, HXQ4, LH, LHE, LHQ4, LW, LX, LXE, LXQ4, LXZ, LX16, L1, PX, QA, QAE, QAQ4, QE, QH, QHE, QHE4, QHQ4, QME2, QP, QT, QX, QXB, QXE, QXEB, QXE4, QXQ4, Q1, RH, RHE, RHE4, RHQ4, RX, RXQ4, R1, SE, SH, SHE, SHEZ, SHQ4, SME1, SME6, SW, SWE, SX, SXB, SXE, SXEB, SXE4, SXQ4, VD16, VEB6, VH, VNG1, VSD, VX, VXB, VXE, VXEB, VXE4, VXG, VXQ4, VXU, V1, W1
	99101-ZF5-0900	JET, MAIN, #90 (CARBURETOR NO.)	(1)	(1)	-	BE24B	B L1, QHC, QSC, QXC, QXC4, Q1, Q2, R1, V1, W1
	99101-ZF5-0920	JET, MAIN, #92 (CARBURETOR NO.)	(1)	(1)	-	BE24B	B L1, QHC, QSC, QXC, QXC4, Q1, Q2, R1, V1, W1
	99101-ZF5-0950	JET, MAIN, #95 (CARBURETOR NO.)	1	1	-	BE24B	B L1, QHC, QSC, QXC, QXC4, Q1, Q2, R1, V1, W1
	99101-ZH7-0800	JET, MAIN, #80 (CARBURETOR NO.)	(1)	-	-	BE75B	A HX26, PX26, QAE6, QH26, QXE6, QX26, RH26, VXB2, VXB6, VX26
	99101-ZH7-0820	JET, MAIN, #82 (CARBURETOR NO.)	(1)	-	-	BE75B	A HX26, PX26, QAE6, QH26, QXE6, QX26, RH26, VXB2, VXB6, VX26
	99101-ZH7-0850	JET, MAIN, #85 (CARBURETOR NO.)	1	-	-	BE75B	A HX26, PX26, QAE6, QH26, QXE6, QX26, RH26, VXB2, VXB6, VX26
	99101-ZH7-0880	JET, MAIN, #88 (CARBURETOR NO.)	(1)	-	-	BE75A	A HAQ, QAQ, QSC9, QXC6, QXC9
	99101-ZH7-0900	JET, MAIN, #90 (CARBURETOR NO.)	(1)	-	-	BE75A	A HAQ, QAQ, QSC9, QXC6, QXC9
	99101-ZH7-0920	JET, MAIN, #92 (CARBURETOR NO.)	1	-	-	BE75A	A HAQ, QAQ, QSC9, QXC6, QXC9
	99101-ZH8-0800	JET, MAIN, #80 (CARBURETOR NO.)	(1)	-	-	BE21A	C HX8, LXE8, LXU, PXU, QAB3, QHP1, QHZ, QMH, QSE, QSE8, QXE8, QXU, RXU, SWC4, SXE8, SXU, VXTB, VXU1
	99101-ZH8-0820	JET, MAIN, #82 (CARBURETOR NO.)	(1)	-	-	BE21B	B WMT8
	99101-ZH8-0850	JET, MAIN, #85 (CARBURETOR NO.)	(1)	-	-	BE21A	C SMD, VDE
	99101-ZH8-0880	JET, MAIN, #88 (CARBURETOR NO.)	(1)	-	-	BE21A	C HX8, LXE8, LXU, PXU, QAB3, QHP1, QHZ, QMH, QSE, QSE8, QXE8, QXU, RXU, SMD, SWC4, SXE8, SXU, VDE, VXTB, VXU1
	99101-ZH8-0800	JET, MAIN, #80 (CARBURETOR NO.)	(1)	-	-	BE21B	B WMT8
	99101-ZH8-0850	JET, MAIN, #85 (CARBURETOR NO.)	(1)	-	-	BE21A	C HX, HXQ4, LH, LHE, LX, LXE, LXQ4, LX16, PX, QAQ4, QH, QHE4, QHQ4, QME2, QX, QXB, QXE, QXE4, QXQ4, RH, RHE4, RHQ4, RX, RXQ4, SH, SHQ4, SME1, SX, SXB, SXE, SXEB, SXE4, SXQ4, VD16, VEB6, VH, VNG1, VSD, VX, VXB, VXE, VXEB, VXE4, VXG, VXQ4, VXU
	99101-ZH8-0850	JET, MAIN, #85 (CARBURETOR NO.)	(1)	-	-	BE21A	C HX, HXQ4, LH, LHE, LX, LXE, LXQ4, LX16, PX, QAQ4, QH, QHE4, QHQ4, QME2, QX, QXB, QXE, QXE4, QXQ4, RH, RHE4, RHQ4, RX, RXQ4, SH, SHQ4, SME1, SX, SXB, SXE, SXEB, SXE4, SXQ4, VD16, VEB6, VH, VNG1, VSD, VX, VXB, VXE, VXEB, VXE4, VXG, VXQ4, VXU

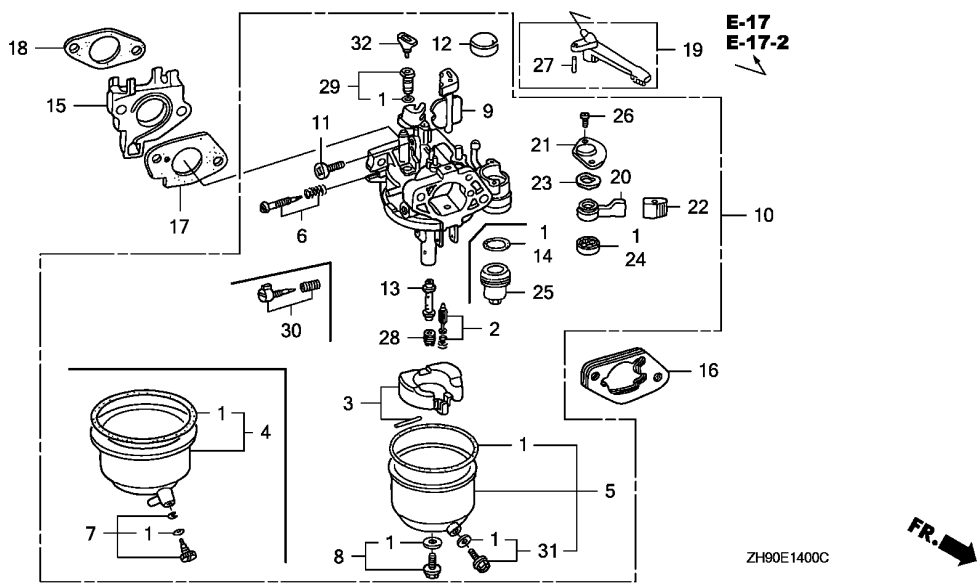

Ref. No.	Part No.	Description	Reqd. QTY			Serial No.		Parts catalogue code
			(1)	(2)	(3)	GX270		
28)	99101-ZH8-0880	JET, MAIN, #88 (CARBURETOR NO.)	1	-	-	BE21A C	BE21A C	HX,HXQ4,LH,LHE,LX,LXE,LXQ4,LX16,PX,QAQ4,QH,QHE4,QHQ4,QME2,QX,QXB,QXE,QXE4,QXQ4,RH,RHE4,RHQ4,RX,RXQ4,SH,SHQ4,SME1,SX,SXB,SXE,SXEB,SXE4,SXQ4,VD16,VEB6,VH,VNG1,VSD,VX,VXB,VXE,VXEB,VXE4,VXG,VXQ4,VXU
	99101-ZF5-0820	JET, MAIN, #82 (CARBURETOR NO.)	(1)	-	-	-----	BE21A B	HA,HEA,PA,QA,QAE,RA,SJP,SK,VA,VAW,VAW1,VWA
	99101-ZF5-0850	JET, MAIN, #85 (CARBURETOR NO.)	-	(1)	-	-----	BE24B C	L1/A,Q1/A,R1/A,S1/A,W1/A
	99101-ZF5-0880	JET, MAIN, #88 (CARBURETOR NO.)	(1)	-	-	-----	BE21A B	HA,HEA,PA,QA,QAE,RA,SJP,SK,VA,VAW,VAW1,VWA
	99101-ZF5-0900	JET, MAIN, #90	-	(1)	-	-----	BE24B C	L1/A,Q1/A,R1/A,S1/A,W1/A
	99101-ZF5-0920	JET, MAIN, #92	-	(1)	-	-----	L1	L1/A,Q1,Q1/A,R1,R1/A,S1,S1/A,V1,W1,W1/A
	99101-ZF5-0950	JET, MAIN, #95	-	1	-	-----	L1	L1/A,Q1,Q1/A,R1,R1/A,S1,S1/A,V1,W1,W1/A

Ref. No.	Part No.	Description	Reqd. QTY			Serial No.	Parts catalogue code
			(1)	(2)	(3)		
28)	99101-ZH8-0800	JET, MAIN, #80	(1)	(1)	-	HA2, HA2/A, HEA2, HEA2/A, HEA8, HEA8/A, HX/A, HXQ4/A, HX26/A, HX8/A, LH/A, LHB1, LHB3, LHB5, LHE/A, LX/A, LXE/A, LXE8/A, LXQ4/A, LXU/A, L1, L1/A, PAE2, PAE2/A, PA2, PA2/A, PX/A, PXE8, PXE8/A, PXU/A, PX26/A, QAB1, QAB3/A, QAE2, QAE2/A, QAE6/A, QAG, QAG/A, QAG2, QAG2/A, QAQ4/A, QAR2, QAR2/A, QAW, QAW/A, QA2, QA2/A, QH/A, QHB5, QHE4/A, QHP1/A, QHQ4/A, QHR, QHR/A, QHR4, QHR4/A, QHZ/A, QH26/A, QKE4, QL2, QME2/A, QMH/A, QSE/A, QSE2, QSE8/A, QX/A, QXB/A, QXB6, QXB6/A, QXB7, QXB7/A, QXE/A, QXE4/A, QXE6/A, QXE8/A, QXQ4/A, QXU/A, QX26/A, Q1, Q1/A, RA2, RA2/A, RHE4/A, RHQ4/A, RH26/A, RSC2, RSC2/A, RSS, RSS/A, RX/A, RXQ4/A, RXU/A, R1, R1/A, SH/A, SHQ4/A, SKE1, SME1/A, SMX2, SWA4, SWC4/A, SX/A, SXB/A, SXB7, SXB7/A, SXE/A, SXE8/A, SXE4/A, SXE8/A, SXQ4/A, SXU/A, SX2, VAG2, VAG2/A, VA2, VA2/A, VDE2, VDE2/A, VKB2, VKB2/A, VME2, VME2/A, VM2, VM2/A, VNG1/A, VNT2, VNT2/A, VN17, VN17/A, VSD/A, VSD7/A, VSH7, VWA2, VWA2/A, VWN2, VWN2/A, VW12, VW12/A, VW22, VX/A, VXB/A, VXB7, VXB7/A, VXEB/A, VXE4/A, VXE6, VXE6/A, VXE7, VXE7/A, VXQ4/A, VXU/A, VXU1/A, WMA4, WMT8/A, WXE8, WXE8/A, W1, W1/A	
		(CARBURETOR NO.)	(1)	-	-	BE75B B	HX, HXQ4, HX26, HX8, LH, LHE, LX, LXE, LXE8, LXQ4, LXU, LX16, PX, PXU, PX26, QAB3, QAE6, QAQ4, QH, QHE4, QHP1, QHQ4, QHZ, QH26, QME2, QMH, QSE, QSE8, QX, QXB, QXE, QXE4, QXE6, QXE8, QXQ4, QXU, QX26, RH, RHE4, RHQ4, RH26, RX, RXQ4, RXU, SH, SHQ4, SMD, SME1, SWC4, SX, SXB, SXE, SXE8, SXE4, SXE8, SXQ4, SXU, VDE, VD16, VEB6, VH, VNG1, VSD, VX, VXB, VXB2, VXB6, VXE, VXEB, VXE4, VXG, VXQ4, VXTB, VXU, VXU1, VX26
	99101-ZH8-0820	JET, MAIN, #82	(1)	-	-	BE76C A	WMT8
		(CARBURETOR NO.)	(1)	(1)	-	ES1, ES1/A, HA2, HA2/A, HEA2, HEA2/A, HEA8, HEA8/A, HX/A, HXQ4/A, HX26/A, HX8/A, LH/A, LHB5, LHE/A, LJ, LJ/A, LJC, LJC/A, LJG, LJG/A, LSS, LT, LT/A, LTJ, LW/A, LWD1, LWD1/A, LX/A, LXE/A, LXE8/A, LXQ4/A, LXU/A, L1/A, PAE2, PAE2/A, PA2, PA2/A, PX/A, PXE8, PXE8/A, PXU/A, PX26/A, QAB3/A, QAE2, QAE2/A, QAE6/A, QAG, QAG/A, QAG2, QAG2/A, QAQ4/A, QAR2, QAR2/A, QAW, QAW/A, QA2, QA2/A, QD, QD/A, QE/A, QH/A, QHB5, QHE4/A, QHP1/A, QHQ4/A, QHR, QHR/A, QHR4, QHR4/A, QHZ/A, QH26/A, QKE3, QKE3/A, QKE4, QL2, QME2/A, QMH/A, QP/A, QSE/A, QSE2, QSE8/A, QT/A, QX/A, QXB/A, QXB6/A, QXB7, QXB7/A, QXE/A, QXE4/A, QXE6/A, QXE8/A, QXQ4/A, QXU/A, QX26/A, Q1/A, RA2, RA2/A, RD, RD/A, RHE4/A, RHQ4/A, RH26/A, RSC2, RSC2/A, RSS, RSS/A, RX/A, RXQ4/A, RXU/A, R1/A, SD, SD/A, SE/A, SH/A, SHQ4/A, SJ, SJ/A, SJG, SJG/A, SMC4, SMC4/A, SME1/A, SME6/A, SMX2, SN, SN/A, SWA4, SWC4/A, SX/A, SXB/A, SXB7, SXB7/A, SXE/A, SXE8/A, SXE4/A, SXE8/A, SXQ4/A, SXU/A, SX2, S1, S1/A, VAG2, VAG2/A, VA2, VA2/A, VDE2, VDE2/A, VKB2, VKB2/A, VME2, VME2/A, VM2, VM2/A, VNG1/A, VNT2, VNT2/A, VN17, VN17/A, VSD/A, VSD7, VSD7/A, VSH7, VWA2, VWA2/A, VWN2, VWN2/A, VWT4, VWT4/A, VW12, VW12/A, VW22, VX/A, VXB/A, VXB7, VXB7/A, VXEB/A, VXE4/A, VXE6/A, VXE7, VXE7/A, VXQ4/A, VXT1, VXT1/A, VXU/A, VXU1/A, WMA4, WMT8/A, WXE8, WXE8/A, W1/A	
		(CARBURETOR NO.)	(1)	(1)	-	BE21A C	HA, HEA, HH, LHQ4, LW, LXZ, L1, PA, QA, QAE, QE, QHE, QP, QT, QXEB, Q1, RA, RHE, R1, SE, SHE, SHEZ, SJP, SK, SME6, SW, SWE, VA, VAW, VAW1, VWA, V1, W1
		//	(1)	-	-	BE75B B	HX, HXQ4, HX26, HX8, LH, LHE, LX, LXE, LXE8, LXQ4, LXU, LX16, PX, PXU, PX26, QAB3, QAE6, QAQ4, QH, QHE4, QHP1, QHQ4, QHZ, QH26, QME2, QMH, QSE, QSE8, QX, QXB, QXB6, QXE, QXE4, QXE6, QXE8, QXQ4, QXU, QX26, RH, RHE4, RHQ4, RH26, RX, RXQ4, RXU, SH, SHQ4, SMD, SME1, SWC4, SX, SXB, SXE, SXE8, SXE4, SXE8, SXQ4, SXU, VDE, VD16, VEB6, VH, VNG1, VSD, VX, VXB, VXE, VXEB, VXE4, VXE6, VXG, VXQ4, VXTB, VXU, VXU1
		//	(1)	-	-	BE76C A	WMT8



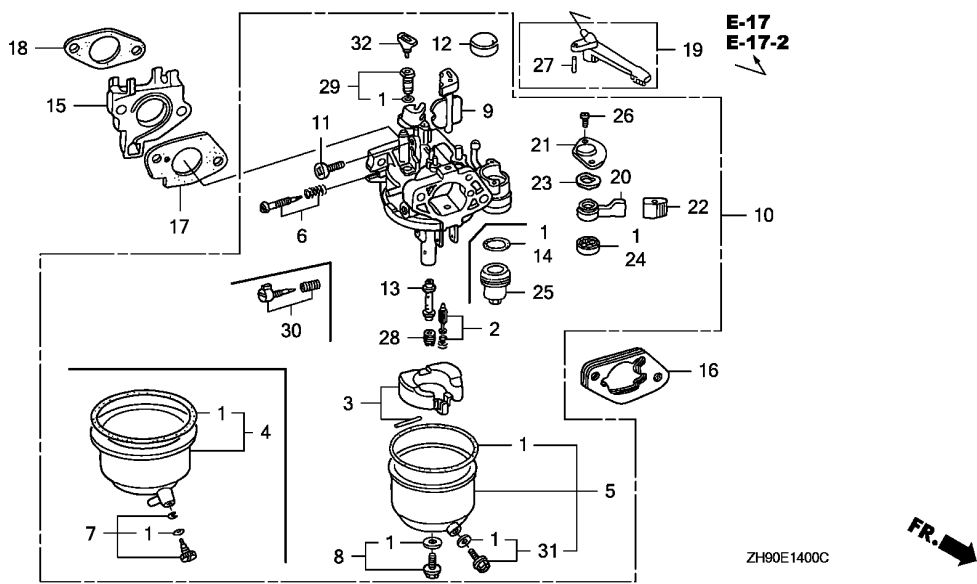

Ref. No.	Part No.	Description	Reqd. QTY			Serial No.	Parts catalogue code
			(1)	(2)	(3)		
28)	99101-ZH8-0850	JET, MAIN, #85	1	-	-	HA2,HA2/A,HEA2,HEA2/A,HEA8,HEA8/A,HX/A,HXQ4/A,HX26/A,HX8/A,LH/A,LHB5,LHE/A,LX/A,LXE/A,LXE8/A,LXQ4/A,LXU/A,PAE2,PAE2/A,PA2,PA2/A,PX/A,PXE8,PXE8/A,PXU/A,PX26/A,QAB3/A,QAE2,QAE2/A,QAE6/A,QAG,QAG/A,QAG2,QAG2/A,QAQ4/A,QAR2,QAR2/A,QAW,QAW/A,QA2,QA2/A,QH/A,QHB5,QHE4/A,QHP1/A,QHQ4/A,QHR,QHR/A,QHR4,QHR4/A,QHZ/A,QH26/A,QKE4,QL2,QME2/A,QMH/A,QSE/A,QSE2,QSE8/A,QX/A,QXB/A,QXB6,QXB6/A,QXB7,QXB7/A,QXE/A,QXE4/A,QXE6/A,QXE8/A,QXQ4/A,QXU/A,QX26/A,RA2,RA2/A,RHE4/A,RHQ4/A,RH26/A,RSC2,RSC2/A,RSS,RSS/A,RX/A,RXQ4/A,RXU/A,SH/A,SHQ4/A,SMC4,SMC4/A,SME1/A,SMX2,SWA4,SWC4/A,SX/A,SXB/A,SXB7,SXB7/A,SXE/A,SXEB/A,SXE4/A,SXE8/A,SXQ4/A,SXU/A,SX2,VAG2,VAG2/A,VA2,VA2/A,VDE2,VDE2/A,VKB2,VKB2/A,VME2,VME2/A,VM2,VM2/A,VNG1/A,VNT2,VNT2/A,VN17,VN17/A,VSD/A,VSD7,VSD7/A,VSH7,VWA2,VWA2/A,VWN2,VWN2/A,VW12,VW12/A,VW22,VX/A,VXB/A,VXB7,VXB7/A,VXEB/A,VXE4/A,VXE6,VXE6/A,VXE7,VXE7/A,VXQ4/A,VXT1,VXT1/A,VXU/A,VXU1/A,WMA4,WMT8/A,WXE8,WXE8/A	
	(CARBURETOR NO.)		1	-	-	BE75B B	HX,HXQ4,HX26,HX8,LH,LHE,LX,LXE,LXE8,LXQ4,LXU,LX16,PX,PXU,PX26,QAB3,QAE6,QAQ4,QH,QHE4,QHP1,QHQ4,QHZ,QH26,QME2,QMH,QSE,QSE8,QX,QXB,QXE,QXE4,QXE6,QXE8,QXQ4,QXU,QX26,RH,RHE4,RHQ4,RH26,RX,RXQ4,RXU,SH,SHQ4,SMD,SME1,SWC4,SX,SXB,SXE,SXEB,SXE4,SXE8,SXQ4,SXU,VDE,VD16,VEB6,VH,VNG1,VSD,VX,VXB,VXB2,VXB6,VXE,VXEB,VXE4,VXG,VXQ4,VXTB,VXU,VXU1,VX26
	"/		1	-	-	BE76C A	WMT8
	(CARBURETOR NO.)		(1)	(1)	-	BE21A C	ES1,ES1/A,LHB1,LHB3,LJ,LJ/A,LJC,LJC/A,LJG,LJG/A,LSS,LT,LT/A,LTJ,LW/A,LWD1,LWD1/A,L1/A,QAB1,QD,QD/A,QA,QAE,QAE3,QAE3/A,QA2,QA2/A,Q1/A,RD,RD/A,R1/A,SD,SD/A,SE/A,SJ,SJ/A,SJG,SJG/A,SKE1,SME6/A,SN,SN/A,S1,S1/A,VWT4,VWT4/A,W1/A
	(CARBURETOR NO.)		(1)	(1)	-	BE21A C	HA,HEA,HH,LHQ4,LW,LXZ,L1,PA,QA,QAE,QE,QHE,QP,QT,QXEB,Q1,RA,RHE,R1,SE,SHE,SHZ,SJP,SK,SME6,SW,SWE,VA,VAW,VAW1,VWA,V1,W1

Ref. No.	Part No.	Description	Reqd. QTY			Serial No.	Parts catalogue code
			(1)	GX270 (2)	(3)		
28)	99101-ZH8-0880	JET, MAIN, #88	1	1	-	-----	ES1,ES1/A,LHB1,LHB3,LJ,LJ/A,LJC,LJC/A,LJG,LJG/A,LSS,LT,LT/A,LTJ LW/A,LWD1,LWD1/A,L1/A,QAB1,QD,QD/A,QE/A,QKE3,QKE3/A,QP/A,QT/A Q1/A,RD,RD/A,R1/A,SD,SD/A,SE/A,SJ,SJ/A,SJG,SJG/A,SKE1,SMC4,SMC4/A SME6/A,SN,SN/A,S1,S1/A,VWT4,VWT4/A,VXT1,VXT1/A,W1/A
		(CARBURETOR NO.)	1	1	-	BE21A C	HA,HEA,HH,LHQ4,LW,LXZ,L1,PA,QA,QAE,QE,QHE,QP,QT,QXEB,Q1,RA,RHE,R1 SE,SHE,SHEZ,SJP,SK,SME6,SW,SWE,VA,VAW,VAW1,VWA,V1,W1
		(CARBURETOR NO.)	(1)	-	-	-----	LWD,QSC9/A,QWA2,QWA4,QWA4/A,QWH2,QWH2/A,QXC6/A,QXC9/A,VMA4,VME4
	99101-ZH8-0900	JET, MAIN, #90	(1)	(1)	-	-----	HAQ,QAQ,QSC9,QXC6,QXC9
		(CARBURETOR NO.)	(1)	(1)	-	BE24B C	LWD,L1/A,QSC9/A,QWA2,QWA4,QWA4/A,QWH2,QWH2/A,QXC4/A,QXC6/A,QXC9/A Q1/A,R1/A,VMA4,VME4,W1/A
		(CARBURETOR NO.)	(1)	-	-	BE75A B	L1,QHC,QSC,QXC,QXC4,Q1,Q2,R1,V1,W1
	99101-ZH8-0920	JET, MAIN, #92	1	(1)	-	-----	HAQ,QAQ,QSC9,QXC6,QXC9
		(CARBURETOR NO.)	1	-	-	BE75A B	LWD,L1/A,QSC9/A,QWA2,QWA4,QWA4/A,QWH2,QWH2/A,QXC6/A,QXC9/A,Q1/A R1/A,VMA4,VME4,W1/A
		//	(1)	(1)	-	BE24B C	HAQ,QAQ,QSC9,QXC6,QXC9
		//	(1)	-	-	-----	L1,QHC,QSC,QXC,QXC4,Q1,Q2,R1,V1,W1
		//	(1)	-	-	-----	QXC4/A
	99101-ZH8-0950	JET, MAIN, #95	1	1	-	-----	L1/A,QXC4/A,Q1/A,R1/A,W1/A
		(CARBURETOR NO.)	1	1	-	BE24B C	L1,QHC,QSC,QXC,QXC4,Q1,Q2,R1,V1,W1
29	99204-ZE0-0350	JET SET, PILOT, #35	1	-	-	-----	HAQ,QAQ,QSC9,QSC9/A,QWA2,QWA4,QWA4/A,QWH2,QWH2/A,QXC6,QXC6/A,QXC9 QXC9/A,VMA4,VME4
	99204-ZE0-0400	JET SET, PILOT, #40	1	(1)	-	-----	ES1,HH,LHB1,LHB3,LHQ4,LJC,LT,LW,LWD1,LXZ,LX16,L1,QAB1,QD,QD/A,QE QHC,QHE,QKE3,QP,QT,QXC4,QXC4/A,QXEB,Q1,Q2,RD,RD/A,RHE,R1,SD,SD/A SE,SHE,SHEZ,SKE1,SMC4/A,SME6,SN/A,SW,SWE,S1,VD16,VEB6,VWT4,VXT1 V1,W1
		(CARBURETOR NO.)	1	(1)	-	BE21A C	ES1/A,HX,HXQ4,HX8,LH,LHE,LJ/A,LJC/A,LJG/A,LT/A,LW/A,LWD1/A,LX,LXE LXE8,LXQ4,LXU,L1/A,PX,PXU,QAB3,QAQ4,QE/A,QH,QHE4,QHP1,QHQ4,QHZ QKE3/A,QME2,QMH,QP/A,QSE,QSE8,QT/A,QX,QXB,QXE,QXE4,QXE8,QXQ4,QXU Q1/A,RH,RHE4,RHQ4,RX,RXQ4,RXU,R1/A,SE/A,SH,SHQ4,SJ/A,SJG/A,SMD SME1,SME6/A,SWC4,SX,SXB,SXE,SXEB,SXE4,SXE8,SXQ4,SXU,S1/A,VDE,VH VNG1,VSD,VWT4/A,VX,VXB,VXE,VXEB,VXE4,VXG,VXQ4,VXTB,VXT1/A,VXU VXU1,W1/A
		//	1	-	-	BE21A C	HA,HEA,LJ,LJG,LSS,LTJ,PA,QA,QAE,RA,SJ,SJG,SJP,SK,VA,VAW,VAW1,VWA
		//	1	-	-	BE21B B	SMC4,SN
		//	1	-	-	BE24B C	QSC,QXC
		//	1	-	-	BE21B B	WMT8
		//	-	(1)	-	BE24B C	L1/A,Q1/A,R1/A,S1/A,W1/A
		//	-	(1)	-	BE21B B	L1/A,Q1/A,R1/A,S1/A,W1/A
	99204-ZE2-0380	JET SET, PILOT, #38	1	-	-	-----	LWD



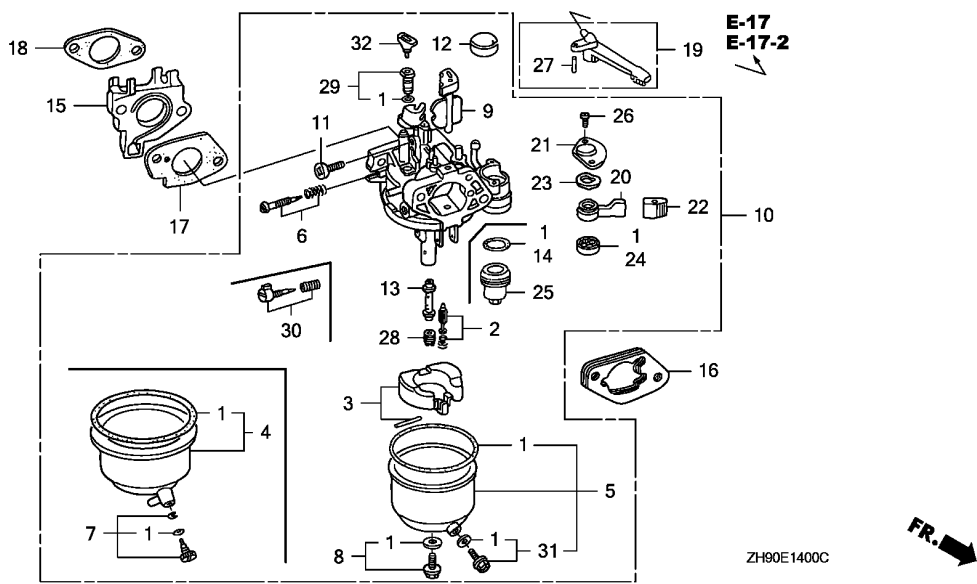

2

Ref. No.	Part No.	Description	Reqd. QTY			Serial No.	Parts catalogue code
			(1)	(2)	(3)		
29)	99204-ZE2-0400	JET SET, PILOT, #40	1	(1)	-	-----	HA2,HA2/A,HEA,HEA2,HEA2/A,HEA8,HEA8/A,HX/A,HXQ4/A,HX26,HX26/A,HX8/A,LH/A,LHB5,LHE/A,LX/A,LXE/A,LXE8/A,LXQ4/A,LXU/A,PAE2,PAE2/A,PA2,PA2/A,PX/A,PXE8,PXE8/A,PXU/A,PX26,PX26/A,QAB3/A,QAE2,QAE2/A,QAE6,QAE6/A,QAG,QAG/A,QAG2,QAG2/A,QAQ4/A,QAR2,QAR2/A,QAW,QAW/A,QA2,QA2/A,QH/A,QHB5,QHE4/A,QHP1/A,QHQ4/A,QHR,QHR/A,QHR4,QHR4/A,QHZ/A,QH26,QH26/A,QKE4,QL2,QME2/A,QMH/A,QSE/A,QSE2,QSE8/A,QX/A,QXB/A,QXB6,QXB6/A,QXB7,QXB7/A,QXE/A,QXE4/A,QXE6,QXE6/A,QXE8/A,QXQ4/A,QXU/A,QX26,QX26/A,Q2,RA2,RA2/A,RHE4/A,RHQ4/A,RH26,RH26/A,RSC2,RSC2/A,RSS,RSS/A,RX/A,RXQ4/A,RXU/A,SH/A,SHQ4/A,SME1/A,SMX2,SWA4,SWC4/A,SX/A,SXB/A,SXB7,SXB7/A,SXE/A,SXEB/A,SXE4/A,SXE8/A,SXQ4/A,SXU/A,SX2,VAG2,VAG2/A,VAW1,VA2,VA2/A,VDE2,VDE2/A,VKB2,VKB2/A,VME2,VME2/A,VM2,VM2/A,VNG1/A,VNT2,VNT2/A,VN17,VN17/A,VSD/VSD7,VSD7/A,VSH7,VMA,VMA2,VMA2/A,VWN2,VWN2/A,VW12,VW12/A,VW22,VX/A,VXB/A,VXB2,VXB6,VXB7,VXB7/A,VXEB/A,VXE4/A,VXE6,VXE6/A,VXE7,VXE7/A,VXQ4/A,VXU/A,VXU1/A,VX26,WMA4,WMT8/A,WXE8,WXE8/A
		(CARBURETOR NO.)	1	(1)	-	BE21A B	LJG,LSS,LTJ,L1,Q1,R1,SJ,SJG,SJP,SK,S1,V1,W1
		//	1	-	-	BE75B B	HX,HXQ4,HX8,LH,LHE,LX,LXE,LXE8,LXQ4,LXU,PX,PXU,QAB3,QAQ4,QH,QHE4,QHP1,QHQ4,QHZ,QME2,QMH,QSE,QSE8,QX,QXB,QXE,QXE4,QXE8,QXQ4,QXU,RH,RHE4,RHQ4,RX,RXQ4,RXU,SH,SHQ4,SMD,SME1,SWC4,SX,SXB,SXE,SXEB,SXE4,SXE8,SXQ4,SXU,VDE,VH,VNG1,VSD,VX,VXB,VXE,VXEB,VXE4,VXG,VXQ4,VXTB,VXU,VXU1
		//	1	-	-	BE76C A	WMT8
		//	1	-	-	BE21B A	SMC4,SN
		//	-	(1)	-	BE24B D	L1/A,Q1/A,R1/A,S1/A,W1/A
		//	1	(1)	-	BE21A D	ES1/A,LJ/A,LJC/A,LJG/A,LT/A,LW/A,LWD1/A,L1/A,QE/A,QKE3/A,QP/A,QT/A,Q1/A,R1/A,SE/A,SJ/A,SJG/A,SME6/A,S1/A,VWT4/A,VXT1/A,W1/A
		(CARBURETOR NO.)	1	-	-	-----	SWA4
		//	-	(1)	-	BE21B C	L1/A,Q1/A,R1/A,S1/A,W1/A

Ref. No.	Part No.	Description	Reqd. QTY			Serial No.	Parts catalogue code
			(1)	(2)	(3)		
30	16016-ZH7-W01	SCREW SET, PILOT (CARBURETOR NO.)	1	(1)	-	BE24B D	L1/A,QXC4/A,Q1/A,R1/A,S1/A,W1/A HAQ,HA2,HA2/A,HEA2,HEA2/A,HEA8,HEA8/A,HX/A,HXQ4/A,HX26,HX26/A HX8/A,LH/A,LHB5,LHE/A,LX/A,LXE/A,LXE8/A,LXQ4/A,LXU/A,LX16,PAE2 PAE2/A,PA2,PA2/A,PX/A,PXE8,PXE8/A,PXU/A,PX26,PX26/A,QAB3/A,QAE2 QAE2/A,QAE6,QAE6/A,QAG,QAG/A,QAG2,QAG2/A,QAQ,QAQ4/A,QAR2,QAR2/A QAW,QAW/A,QA2,QA2/A,QH/A,QHB5,QHE4/A,QHP1/A,QHQ4/A,QHR,QHR/A,QHR4 QHR4/A,QHZ/A,QH26,QH26/A,QKE4,QL2,QME2/A,QMH/A,QSC9,QSC9/A,QSE/A QSE2,QSE8/A,QWA2,QWA4,QWA4/A,QWH2,QWH2/A,QX/A,QXB/A,QXB6,QXB6/A QXB7,QXB7/A,QXC6,QXC6/A,QXC9,QXC9/A,QXE/A,QXE4/A,QXE6,QXE6/A QXE8/A,QXQ4/A,QXU/A,QX26,QX26/A,RA2,RA2/A,RHE4/A,RHQ4/A,RH26 RH26/A,RSC2,RSC2/A,RSS,RSS/A,RX/A,RXQ4/A,RXU/A,SH/A,SHQ4/A,SME1/A SMX2,SWA4,SWC4,SWC4/A,SX/A,SXB/A,SXB7,SXB7/A,SXE/A,SXEB/A,SXE4/A SXE8/A,SXQ4/A,SXU/A,SX2,VAG2,VAG2/A,VA2,VA2/A,VDE2,VDE2/A,VD16 VEB6,VKB2,VKB2/A,VMA4,VME2,VME2/A,VME4,VM2,VM2/A,VNG1/A,VNT2 VNT2/A,VM17,VM17/A,VSD/A,VSD7,VSD7/A,VSH7,VWA2,VWA2/A,VWN2,VWN2/A VW12,VW12/A,VW22,VX/A,VXB/A,VXB2,VXB6,VXB7,VXB7/A,VXEB/A,VXE4/A VXE6,VXE6/A,VXE7,VXE7/A,VXQ4/A,VXU/A,VXU1/A,VX26,WMA4,WMT8/A,WXE8 WXE8/A
		(CARBURETOR NO.)	1	-	-	BE75B B	HX,HXQ4,HX8,LH,LHE,LX,LXE,LXE8,LXQ4,LXU,PX,PXU,QAB3,QAQ4,QH,QHE4 QHP1,QHQ4,QHZ,QME2,QMH,QSE,QSE8,QX,QXB,QXE,QXE4,QXE8,QXQ4,QXU,RH RHE4,RHQ4,RX,RXQ4,RXU,SH,SHQ4,SMD,SME1,SX,SXB,SXE,SXEB,SXE4,SXE8 SXQ4,SXU,VDE,VH,VNG1,VSD,VX,VXB,VXE,VXEB,VXE4,VXG,VXQ4,VXTB,VXU VXU1
	16016-ZH8-W01	SCREW SET (CARBURETOR NO.)	1	-	-	BE76C A	WMT8
		SCREW SET (CARBURETOR NO.)	1	(1)	-	BE21B C	L1/A,QD/A,Q1/A,RD/A,R1/A,SD/A,SMC4/A,SN/A,S1/A,W1/A
		SCREW SET (CARBURETOR NO.)	1	-	-	BE21A D	ES1/A,LJ/A,LJC/A,LJG/A,LT/A,LW/A,LWD1/A,QE/A,QKE3/A,QP/A,QT/A SE/A,SJ/A,SJG/A,SME6/A,VWT4/A,VXT1/A
		SCREW SET (CARBURETOR NO.)	-	(1)	-	BE21A D	L1/A,Q1/A,R1/A,S1/A,W1/A
31	16024-ZE1-811	SCREW SET, DRAIN	1	-	-		HAQ,HA2,HA2/A,HEA2,HEA2/A,HEA8,HEA8/A,HX/A,HXQ4/A,HX26,HX26/A HX8/A,LH/A,LHB5,LHE/A,LX/A,LXE/A,LXE8/A,LXQ4/A,LXU/A,LX16,PAE2 PAE2/A,PA2,PA2/A,PX/A,PXE8,PXE8/A,PXU/A,PX26,PX26/A,QAB3/A,QAE2 QAE2/A,QAE6,QAE6/A,QAG,QAG/A,QAG2,QAG2/A,QAQ,QAQ4/A,QAR2,QAR2/A QAW,QAW/A,QA2,QA2/A,QH/A,QHB5,QHE4/A,QHP1/A,QHQ4/A,QHR,QHR/A,QHR4 QHR4/A,QHZ/A,QH26,QH26/A,QKE4,QL2,QME2/A,QMH/A,QSC9,QSC9/A,QSE/A QSE2,QSE8/A,QWA2,QWA4,QWA4/A,QWH2,QWH2/A,QX/A,QXB/A,QXB6,QXB6/A QXB7,QXB7/A,QXC6,QXC6/A,QXC9,QXC9/A,QXE/A,QXE4/A,QXE6,QXE6/A QXE8/A,QXQ4/A,QXU/A,QX26,QX26/A,RA2,RA2/A,RHE4/A,RHQ4/A,RH26 RH26/A,RSC2,RSC2/A,RSS,RSS/A,RX/A,RXQ4/A,RXU/A,SH/A,SHQ4/A,SME1/A SMX2,SWA4,SWC4,SWC4/A,SX/A,SXB/A,SXB7,SXB7/A,SXE/A,SXEB/A,SXE4/A SXE8/A,SXQ4/A,SXU/A,SX2,VAG2,VAG2/A,VA2,VA2/A,VDE2,VDE2/A,VD16 VEB6,VKB2,VKB2/A,VMA4,VME2,VME2/A,VME4,VM2,VM2/A,VNG1/A,VNT2 VNT2/A,VM17,VM17/A,VSD/A,VSD7,VSD7/A,VSH7,VWA2,VWA2/A,VWN2,VWN2/A VW12,VW12/A,VW22,VX/A,VXB/A,VXB2,VXB6,VXB7,VXB7/A,VXEB/A,VXE4/A VXE6,VXE6/A,VXE7,VXE7/A,VXQ4/A,VXU/A,VXU1/A,VX26,WMA4,WMT8/A,WXE8 WXE8/A
		(CARBURETOR NO.)	1	-	-	BE75B B	HX,HXQ4,HX8,LH,LHE,LX,LXE,LXE8,LXQ4,LXU,PX,PXU,QAB3,QAQ4,QH,QHE4 QHP1,QHQ4,QHZ,QME2,QMH,QSE,QSE8,QX,QXB,QXE,QXE4,QXE8,QXQ4,QXU,RH RHE4,RHQ4,RX,RXQ4,RXU,SH,SHQ4,SMD,SME1,SX,SXB,SXE,SXEB,SXE4,SXE8 SXQ4,SXU,VDE,VH,VNG1,VSD,VX,VXB,VXE,VXEB,VXE4,VXG,VXQ4,VXTB,VXU VXU1
		SCREW SET (CARBURETOR NO.)	1	-	-	BE76C A	WMT8



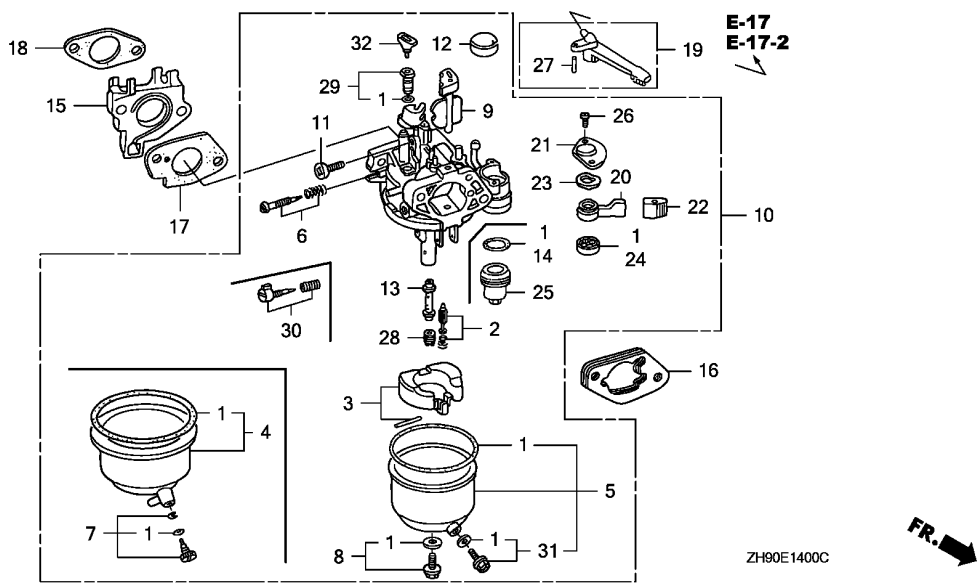

2

Ref. No.	Part No.	Description	Reqd. QTY			Serial No.	Parts catalogue code
			(1)	(2)	(3)		
32	16172-ZE3-W10	COLLAR, SETTING	1	-	-	HAQ,HA2,HA2/A,HEA2,HEA2/A,HEA8,HEA8/A,HX/A,HXQ4/A,HX26,HX26/A,HX8/A,LH/A,LHB5,LHE/A,LX/A,LXE/A,LXE8/A,LXQ4/A,LXU/A,LX16,PAE2,PAE2/A,PA2,PA2/A,PX/A,PXE8,PXE8/A,PXU/A,PX26,PX26/A,QAB3/A,QAE2,QAE2/A,QAE6,QAE6/A,QAG,QAG/A,QAG2,QAG2/A,QAQ,QAQ4/A,QAR2,QAR2/A,QAW,QAW/A,QA2,QA2/A,QH/A,QHB5,QHE4/A,QHP1/A,QHQ4/A,QHR,QHR/A,QHR4,QHR4/A,QHZ/A,QH26,QH26/A,QKE4,QL2,QME2/A,QMH/A,QSC9,QSC9/A,QSE/A,QSE2,QSE8/A,QWA2,QWA4,QWA4/A,QWH2,QWH2/A,QX/A,QXB/A,QXB6,QXB6/A,QXB7,QXB7/A,QXC6,QXC6/A,QXC9,QXC9/A,QXE/A,QXE4/A,QXE6,QXE6/A,QXE8/A,QXQ4/A,QXU/A,QX26,QX26/A,RA2,RA2/A,RHE4/A,RHQ4/A,RH26,RH26/A,RSC2,RSC2/A,RSS,RSS/A,RX/A,RXQ4/A,RXU/A,SH/A,SHQ4/A,SME1/A,SMX2,SWA4,SWC4,SWC4/A,SX/A,SXB/A,SXB7,SXB7/A,SXE/A,SXEB/A,SXE4/A,SXE8/A,SXQ4/A,SXU/A,SX2,VAG2,VAG2/A,VA2,VA2/A,VDE2,VDE2/A,VD16,VEB6,VKB2,VKB2/A,VMA4,VME2,VME2/A,VME4,VM2,VM2/A,VNG1/A,VNT2,VNT2/A,VN17,VN17/A,VSD/A,VSD7,VSD7/A,VSH7,VWA2,VWA2/A,VWN2,VWN2/A,VW12,VW12/A,VW22,VX/A,VXB/A,VXB2,VXB6,VXB7,VXB7/A,VXEB/A,VXE4/A,VXE6,VXE6/A,VXE7,VXE7/A,VXQ4/A,VXU/A,VXU1/A,VX26,WMA4,WMT8/A,WXE8,WXE8/A	
		(CARBURETOR NO.)	1	-	-	BE75B B	HX,HXQ4,HX8,LH,LHE,LX,LXE,LXE8,LXQ4,LXU,PX,PXU,QAB3,QAQ4,QH,QHE4,QHP1,QHQ4,QHZ,QME2,QMH,QSE,QSE8,QX,QXB,QXE,QXE4,QXE8,QXQ4,QXU,RH,RHE4,RHQ4,RX,RXQ4,RXU,SH,SHQ4,SMD,SME1,SX,SXB,SXE,SXEB,SXE4,SXE8,SXQ4,SXU,VDE,VH,VNG1,VSD,VX,VXB,VXE,VXEB,VXE4,VXG,VXQ4,VXTB,VXU1,WMT8
		..	1	-	-	BE76C A	WMT8

E-14-1

CARBURETOR(2)

K 6

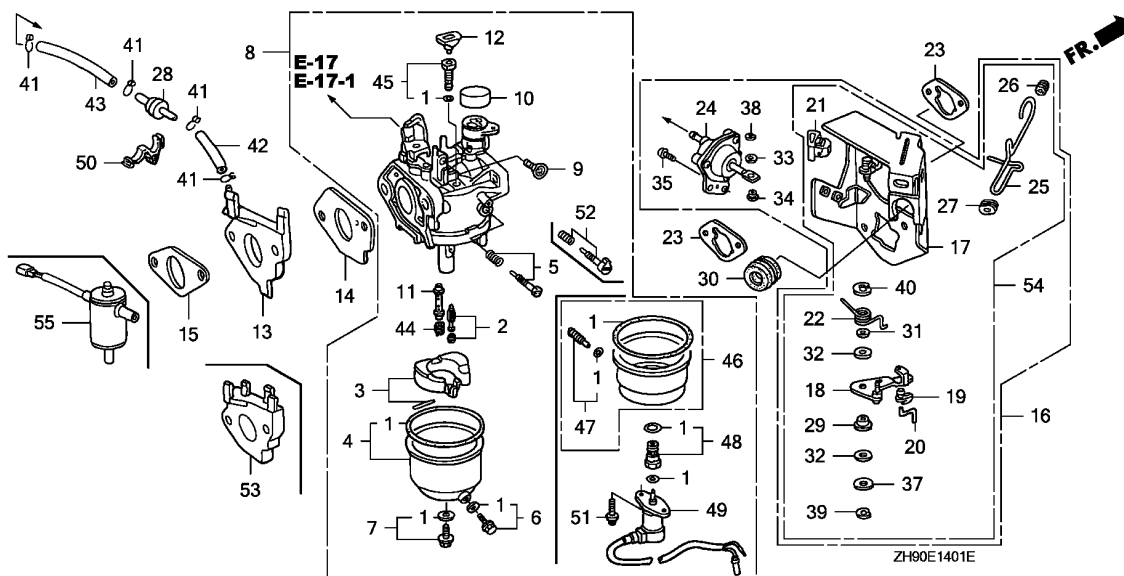

Ref. No.	L.O.N.	(Relative ref. Number) Description	F.R.T.
1	3111G1	GASKET SET, CARBURETOR(A) (3)	0.4
2	3111G6	VALVE SET, FLOAT AND/OR FLOAT SET(A) (52)	0.4
5	3111D7	SCREW SET, PILOT	0.2
8	3111G7	CARBURETOR(A) (15,53)	0.3
13	3111G2	INSULATOR, CARBURETOR AND/OR PACKING, INSULATOR(A)	0.3
14	3111G5	PACKING, CARBURETOR(A)	0.3
16	8101R1	STAY, MANUAL CHOKE	0.3
18	8101F9	LEVER, CARBURETOR CHOKE	0.2
20	8101J8	ROD, CARBURETOR CHOKE	0.2
23	3121D9	PACKING, AIR CLEANER	0.2
24	3111A7	DIAPHRAGM, CARBURETOR	0.3
28	311175	VALVE, DASHPOT CHECK	0.1
44	3111G4	JET, MAIN(A)	0.4
49	6211C0	VALVE, CARBURETOR SOLENOID	0.2

Ref. No.	Part No.	Description	Reqd. QTY			Serial No.	Parts catalogue code
			(1)	(2)	(3)		
1	16010-ZF5-900	GASKET SET	1	-	-	VKX4,VPE4,VPE4/A,VPE5,VPE7,VPE7/A,VPX4,VPX4/A,VPX5,VPX7,VPX7/A VSD3,VSD3/A,VS37,VS37/A	
	16010-ZE3-701		1	-	-	ES3,ES3/A,VKE4,VMS2,VMT,VMT/A,VMX2,VS3	
2	16011-ZA0-931	VALVE SET, FLOAT	1	-	-	ES3,ES3/A,VKE4,VKX4,VMS2,VMT,VMT/A,VMX2,VPE4,VPE4/A,VPE5,VPE7 VPE7/A,VPX4,VPX4/A,VPX5,VPX7,VPX7/A,VSD3,VSD3/A,VS3,VS37,VS37/A	
3	16013-ZA0-931	FLOAT SET	1	-	-	ES3,ES3/A,VKE4,VKX4,VMS2,VMT,VMT/A,VMX2,VPE4,VPE4/A,VPE5,VPE7 VPE7/A,VPX4,VPX4/A,VPX5,VPX7,VPX7/A,VSD3,VSD3/A,VS3,VS37,VS37/A	
4	16015-ZE8-005	CHAMBER SET, FLOAT	1	-	-	VKX4,VPE4,VPE4/A,VPE5,VPE7,VPE7/A,VPX4,VPX4/A,VPX5,VPX7,VPX7/A VSD3,VSD3/A,VS37,VS37/A	
5	16016-ZA0-931	SCREW SET, PILOT (CARBURETOR NO.)	1	-	-	ES3,ES3/A,VMT,VMT/A,VPE4,VPE7,VPX4,VPX7,VSD3,VS3,VS37	
	“	“	1	-	-	BE21D B VKX4,VPE4/A,VPE7/A,VPX4/A,VPX7/A,VSD3/A,VS37/A	
	“	“	1	-	-	BE21E B VKE4	
6	16024-ZE1-811	SCREW SET, DRAIN	1	-	-	VKX4,VPE4,VPE4/A,VPE5,VPE7,VPE7/A,VPX4,VPX4/A,VPX5,VPX7,VPX7/A VSD3,VSD3/A,VS37,VS37/A	
7	16028-ZE0-005	SCREW SET	1	-	-	VKX4,VPE4,VPE4/A,VPE5,VPE7,VPE7/A,VPX4,VPX4/A,VPX5,VPX7,VPX7/A VSD3,VSD3/A,VS37,VS37/A	
8	16100-ZH9-V00	CARBURETOR ASSY. (BE21D A)	1	-	-	1183071 VSD3	
	16100-ZH9-V01	CARBURETOR ASSY. (BE21D B)	1	-	-	VPE4,VPE7,VPX4,VPX7,VS37	
			1	-	-	1183072 VSD3	
			1	-	-	2302737 VKX4,VPE4/A,VPE7/A,VPX4/A,VPX7/A,VSD3/A,VS37/A	
	16100-ZH9-D41	CARBURETOR ASSY. (BE77M A)	1	-	-	ES3,ES3/A,VMT,VMT/A,VS3	
	16100-ZH9-V02	CARBURETOR ASSY. (BE21D C)	1	-	-	2302738 VKX4,VPE4/A,VPE7/A,VPX4/A,VPX7/A,VSD3/A,VS37/A	
	16100-ZH9-V11	CARBURETOR ASSY. (BE21E B)	1	-	-	2341615 VKE4	
	16100-ZK9-R41	CARBURETOR ASSY. (BE77Q A)	1	-	-	VMS2,VMX2	
	16100-ZH9-V12	CARBURETOR ASSY. (BE21E C)	1	-	-	2341616 VKE4	
	16100-ZK9-R61	CARBURETOR ASSY. (BE77R A)	1	-	-	VPE5,VPX5	
9	16124-ZE0-005	SCREW, THROTTLE STOP	1	-	-	ES3,ES3/A,VKE4,VKX4,VMS2,VMT,VMT/A,VMX2,VPE4,VPE4/A,VPE5,VPE7 VPE7/A,VPX4,VPX4/A,VPX5,VPX7,VPX7/A,VSD3,VSD3/A,VS3,VS37,VS37/A	

2

E-14-1

CARBURETOR(2)

K 7

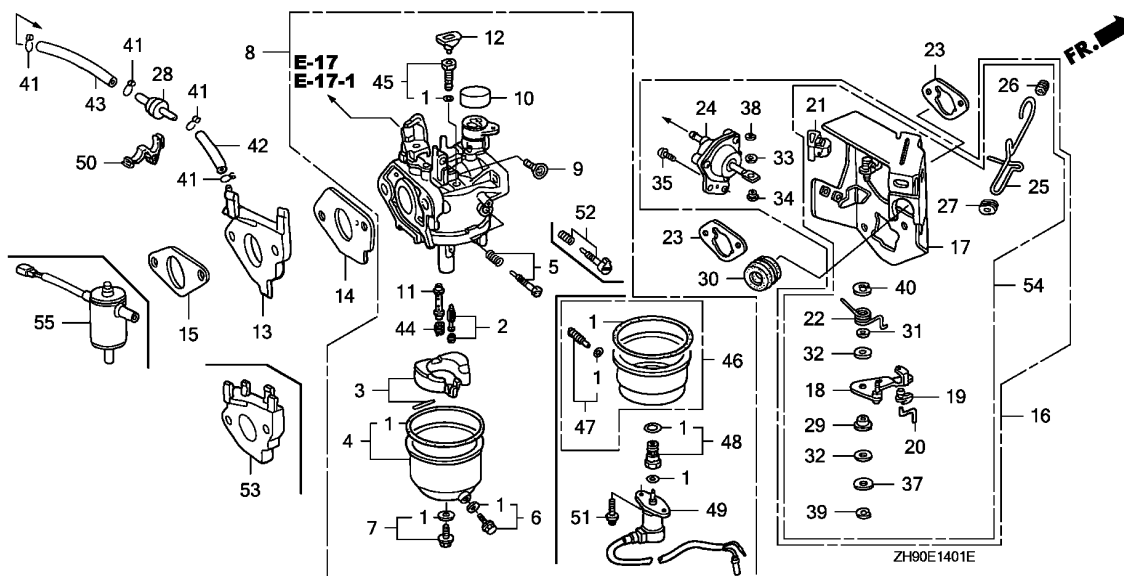

Ref. No.	Part No.	Description	Reqd. QTY			Serial No.	Parts catalogue code
			(1)	(2)	(3)		
10	16148-141-881	CAP, CHOKE DUST	1	-	-	-	ES3, ES3/A, VKE4, VKX4, VMS2, VMT, VMT/A, VMX2, VPE4, VPE4/A, VPE5, VPE7, VPE7/A, VPX4, VPX4/A, VPX5, VPX7, VPX7/A, VSD3, VSD3/A, VS3, VS37, VS37/A
11	16166-ZH9-820	NOZZLE, MAIN	1	-	-	-	ES3, ES3/A, VKE4, VKX4, VMS2, VMT, VMT/A, VMX2, VPE4, VPE4/A, VPE5, VPE7, VPE7/A, VPX4, VPX4/A, VPX5, VPX7, VPX7/A, VSD3, VSD3/A, VS3, VS37, VS37/A
12	16172-ZE3-W10	COLLAR, SETTING	1	-	-	-	ES3, ES3/A, VKE4, VKX4, VMS2, VMT, VMT/A, VMX2, VPE4, VPE4/A, VPE5, VPE7, VPE7/A, VPX4, VPX4/A, VPX5, VPX7, VPX7/A, VSD3, VSD3/A, VS3, VS37, VS37/A
13	16211-ZE2-700	INSULATOR, CARBURETOR	1	-	-	-	ES3, ES3/A, VKE4, VKX4, VMT, VMT/A, VPE4, VPE4/A, VPE5, VPE7, VPE7/A, VPX4, VPX4/A, VPX5, VPX7, VPX7/A, VSD3, VSD3/A, VS3, VS37, VS37/A
14	16221-ZA0-800	PACKING, CARBURETOR	1	-	-	-	ES3, ES3/A, VKE4, VKX4, VMS2, VMT, VMT/A, VMX2, VPE4, VPE4/A, VPE5, VPE7, VPE7/A, VPX4, VPX4/A, VPX5, VPX7, VPX7/A, VSD3, VSD3/A, VS3, VS37, VS37/A
15	16223-ZA0-800	PACKING, INSULATOR	1	-	-	-	ES3, ES3/A, VKE4, VKX4, VMS2, VMT, VMT/A, VMX2, VPE4, VPE4/A, VPE5, VPE7, VPE7/A, VPX4, VPX4/A, VPX5, VPX7, VPX7/A, VSD3, VSD3/A, VS3, VS37, VS37/A
16	16260-ZE2-722	STAY ASSY., MANUAL CHOKE	1	-	-	-	ES3, ES3/A, VKE4, VMT, VMT/A, VPE4, VPE7, VPE7/A, VPX4, VPX7, VPX7/A, VSD3, VSD3/A, VS3, VS37
	16260-ZE2-730		1	-	-	2207390	VKX4, VPE4/A, VPE5, VPX4/A, VPX5, VS37/A
	16260-ZE2-730		1	-	-	2207391	VKX4, VPE4/A, VPE5, VPX4/A, VPX5, VS37/A
17	16261-ZE2-702	STAY COMP., SOLENOID	1	-	-	-	ES3, ES3/A, VKE4, VKX4, VMS2, VMT, VMT/A, VMX2, VPE4, VPE4/A, VPE5, VPE7, VPE7/A, VPX4, VPX4/A, VPX5, VPX7, VPX7/A, VSD3, VSD3/A, VS3, VS37, VS37/A
18	16262-ZE2-711	LEVER, CHOKE	1	-	-	-	ES3, ES3/A, VKE4, VKX4, VMS2, VMT, VMT/A, VMX2, VPE4, VPE4/A, VPE5, VPE7, VPE7/A, VPX4, VPX4/A, VPX5, VPX7, VPX7/A, VSD3, VSD3/A, VS3, VS37, VS37/A
19	16263-ZA0-000	JOINT, ROD	1	-	-	-	ES3, ES3/A, VKE4, VKX4, VMS2, VMT, VMT/A, VMX2, VPE4, VPE4/A, VPE5, VPE7, VPE7/A, VPX4, VPX4/A, VPX5, VPX7, VPX7/A, VSD3, VSD3/A, VS3, VS37, VS37/A
20	16264-ZE2-701	ROD, CHOKE	1	-	-	-	ES3, ES3/A, VKE4, VKX4, VMS2, VMT, VMT/A, VMX2, VPE4, VPE4/A, VPE5, VPE7, VPE7/A, VPX4, VPX4/A, VPX5, VPX7, VPX7/A, VSD3, VSD3/A, VS3, VS37, VS37/A
	16264-ZE2-700		1	-	-	-	VSD3

Ref. No.	Part No.	Description	Reqd. QTY			Serial No.	Parts catalogue code
			(1)	GX270 (2)	(3)		
21	16265-ZE2-721	STOPPER, CHOKE ROD	1	-	-	-	ES3,ES3/A,VKE4,VKX4,VMS2,VMT,VMT/A,VMX2,VPE4,VPE4/A,VPE5,VPE7 VPE7/A,VPX4,VPX4/A,VPX5,VPX7,VPX7/A,VSD3,VSD3/A,VS3,VS37,VS37/A
22	16268-ZE2-721	SPRING, MANUAL CHOKE	1	-	-	-	ES3,ES3/A,VKE4,VKX4,VMS2,VMT,VMT/A,VMX2,VPE4,VPE4/A,VPE5,VPE7 VPE7/A,VPX4,VPX4/A,VPX5,VPX7,VPX7/A,VSD3,VSD3/A,VS3,VS37,VS37/A
23	16269-ZA0-800	PACKING, AIR CLEANER	2	-	-	-	ES3,ES3/A,VKE4,VKX4,VMS2,VMT,VMT/A,VMX2,VPE4,VPE4/A,VPE5,VPE7 VPE7/A,VPX4,VPX4/A,VPX5,VPX7,VPX7/A,VSD3,VSD3/A,VS3,VS37,VS37/A
24	16400-ZE2-703	DIAPHRAGM ASSY.	1	-	-	-	ES3,ES3/A,VKE4,VKX4,VMT,VMT/A,VPE4,VPE4/A,VPE5,VPE7,VPE7/A,VPX4 VPX4/A,VPX5,VPX7,VPX7/A,VSD3,VSD3/A,VS3,VS37,VS37/A
25	16611-ZE2-711	ROD, CHOKE CONTROL	1	-	-	-	ES3,ES3/A,VKE4,VMS2,VMT,VMT/A,VMX2,VPE4,VPE7,VPE7/A,VPX4,VPX7 VPX7/A,VSD3,VSD3/A,VS3,VS37
	16611-ZE3-D21	1	-	-	2207390	VKX4,VPE4/A,VPE5,VPX4/A,VPX5,VS37/A
			1	-	-	2207391	VKX4,VPE4/A,VPE5,VPX4/A,VPX5,VS37/A
26	16613-893-000	GROMMET, CHOKE ROD	1	-	-	-	ES3,ES3/A,VKE4,VKX4,VMS2,VMT,VMT/A,VMX2,VPE4,VPE4/A,VPE5,VPE7 VPE7/A,VPX4,VPX4/A,VPX5,VPX7,VPX7/A,VSD3,VSD3/A,VS3,VS37,VS37/A
27	16615-893-000	GUIDE, CHOKE ROD	1	-	-	-	ES3,ES3/A,VKE4,VKX4,VMS2,VMT,VMT/A,VMX2,VPE4,VPE4/A,VPE5,VPE7 VPE7/A,VPX4,VPX4/A,VPX5,VPX7,VPX7/A,VSD3,VSD3/A,VS3,VS37,VS37/A
28	36135-ZV1-003	VALVE, DASHPOT CHECK	1	-	-	1119302	VSD3
	36135-ZF6-D41	1	-	-	-	ES3,ES3/A,VKE4,VKX4,VMT,VMT/A,VPE4,VPE4/A,VPE5,VPE7,VPE7/A,VPX4 VPX4/A,VPX5,VPX7,VPX7/A,VSD3/A,VS3,VS37,VS37/A
			1	-	-	1119303	VSD3
29	53149-964-003	BUSH, ARM PIVOT	1	-	-	-	ES3,ES3/A,VKE4,VKX4,VMS2,VMT,VMT/A,VMX2,VPE4,VPE4/A,VPE5,VPE7 VPE7/A,VPX4,VPX4/A,VPX5,VPX7,VPX7/A,VSD3,VSD3/A,VS3,VS37,VS37/A
30	88911-MJ3-000	GROMMET, FENDER	1	-	-	-	ES3,ES3/A,VKE4,VKX4,VMS2,VMT,VMT/A,VMX2,VPE4,VPE4/A,VPE5,VPE7 VPE7/A,VPX4,VPX4/A,VPX5,VPX7,VPX7/A,VSD3,VSD3/A,VS3,VS37,VS37/A
31	90431-ZE2-700	WASHER, CHOKE LEVER	1	-	-	-	ES3,ES3/A,VKE4,VKX4,VMS2,VMT,VMT/A,VMX2,VPE4,VPE4/A,VPE5,VPE7 VPE7/A,VPX4,VPX4/A,VPX5,VPX7,VPX7/A,VSD3,VSD3/A,VS3,VS37,VS37/A
32	90432-ZE2-700	SEAL, CHOKE LEVER	2	-	-	-	ES3,ES3/A,VKE4,VKX4,VMS2,VMT,VMT/A,VMX2,VPE4,VPE4/A,VPE5,VPE7 VPE7/A,VPX4,VPX4/A,VPX5,VPX7,VPX7/A,VSD3,VSD3/A,VS3,VS37,VS37/A
33	90433-ZE2-700	WASHER, THRUST, 2.7X8	1	-	-	-	ES3,ES3/A,VKE4,VKX4,VMT,VMT/A,VPE4,VPE4/A,VPE5,VPE7,VPE7/A,VPX4 VPX4/A,VPX5,VPX7,VPX7/A,VSD3,VSD3/A,VS3,VS37,VS37/A
34	90434-ZE2-700	COLLAR, LEVER	1	-	-	-	ES3,ES3/A,VKE4,VKX4,VMT,VMT/A,VPE4,VPE4/A,VPE5,VPE7,VPE7/A,VPX4 VPX4/A,VPX5,VPX7,VPX7/A,VSD3,VSD3/A,VS3,VS37,VS37/A
35	93500-05012-0A	SCREW, PAN, 5X12	2	-	-	-	ES3,ES3/A,VKE4,VKX4,VMT,VMT/A,VPE4,VPE4/A,VPE5,VPE7,VPE7/A,VPX4 VPX4/A,VPX5,VPX7,VPX7/A,VSD3,VSD3/A,VS3,VS37,VS37/A
37	94103-05000	WASHER, PLAIN, 5MM	1	-	-	-	ES3,ES3/A,VKE4,VKX4,VMS2,VMT,VMT/A,VMX2,VPE4,VPE4/A,VPE5,VPE7 VPE7/A,VPX4,VPX4/A,VPX5,VPX7,VPX7/A,VSD3,VSD3/A,VS3,VS37,VS37/A
38	94540-02010	E-RING, 2MM	1	-	-	-	ES3,ES3/A,VKE4,VKX4,VMT,VMT/A,VPE4,VPE4/A,VPE5,VPE7,VPE7/A,VPX4 VPX4/A,VPX5,VPX7,VPX7/A,VSD3,VSD3/A,VS3,VS37,VS37/A
39	94540-04010	E-RING, 4MM	1	-	-	-	ES3,ES3/A,VKE4,VKX4,VMS2,VMT,VMT/A,VMX2,VPE4,VPE4/A,VPE5,VPE7 VPE7/A,VPX4,VPX4/A,VPX5,VPX7,VPX7/A,VSD3,VSD3/A,VS3,VS37,VS37/A
40	94540-07010	E-RING, 7MM	1	-	-	-	ES3,ES3/A,VKE4,VKX4,VMS2,VMT,VMT/A,VMX2,VPE4,VPE4/A,VPE5,VPE7 VPE7/A,VPX4,VPX4/A,VPX5,VPX7,VPX7/A,VSD3,VSD3/A,VS3,VS37,VS37/A
41	95002-02070	CLIP, TUBE (B7)	4	-	-	-	ES3,ES3/A,VKE4,VKX4,VMT,VMT/A,VPE4,VPE4/A,VPE5,VPE7,VPE7/A,VPX4 VPX4/A,VPX5,VPX7,VPX7/A,VSD3,VSD3/A,VS3,VS37,VS37/A
42	95005-35040-10	TUBE, 3.5X40(95005-35001-10M)	1	-	-	1056014	VSD3
	95005-35055-10	TUBE, 3.5X55(95005-35001-10M)	1	-	-	-	VKE4,VKX4,VPE4,VPE4/A,VPE5,VPE7,VPE7/A,VPX4,VPX4/A,VPX5,VPX7 VPX7/A,VSD3/A,VS37,VS37/A
			1	-	-	1056015	VSD3
	95005-35065-10	TUBE, 3.5X65(95005-35001-10M)	1	-	-	-	ES3,ES3/A,VMT,VMT/A,VS3
43	95005-35075-10	TUBE, 3.5X75(95005-35001-10M)	1	-	-	-	VKE4,VKX4,VPE4,VPE4/A,VPE5,VPE7,VPE7/A,VPX4,VPX4/A,VPX5,VPX7 VPX7/A,VSD3,VSD3/A,VS37,VS37/A
	95005-35130-10	TUBE, 3.5X130(95005-35001-10M)	1	-	-	-	ES3,ES3/A,VMT,VMT/A,VS3
44	99101-ZH8-0850	JET, MAIN, #85	(1)	-	-	-	ES3,ES3/A,VMS2,VMT,VMT/A,VMX2,VS3

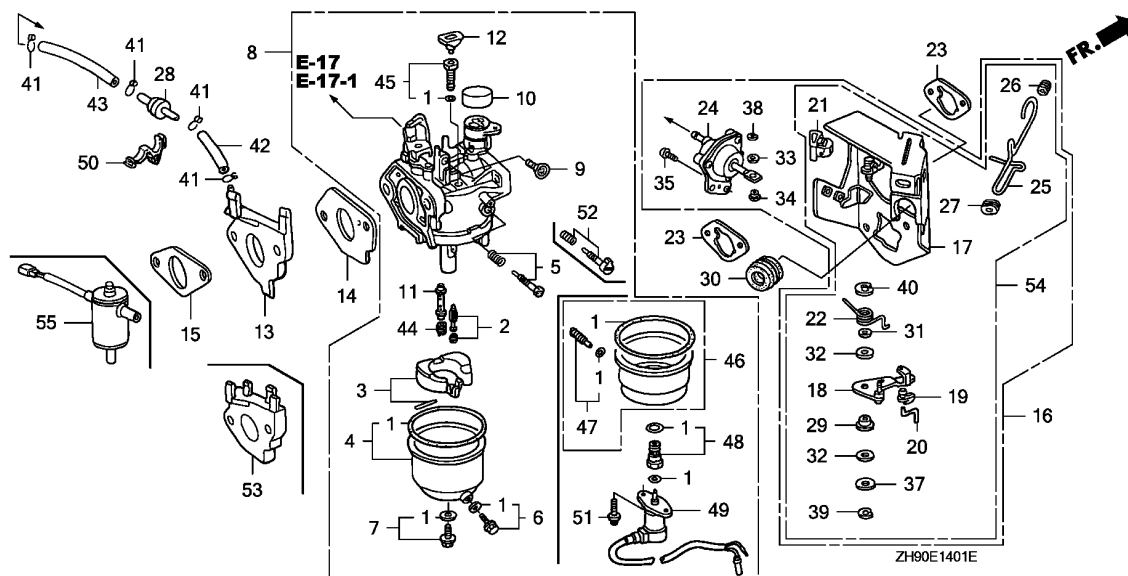

Ref. No.	Part No.	Description	Reqd. QTY			Serial No.	Parts catalogue code
			(1)	(2)	(3)		
44)	99101-ZH8-0880	JET, MAIN, #88	(1)	-	-	-----	ES3,ES3/A,VKE4,VKX4,VMS2,VMT,VMT/A,VMX2,VPE4,VPE4/A,VPE5,VPE7,VPE7/A,VPX4,VPX4/A,VPX5,VPX7,VPX7/A,VSD3,VSD3/A,VS3,VS37,VS37/A
	99101-ZH8-0900	JET, MAIN, #90	1	-	-	-----	ES3,ES3/A,VMS2,VMT,VMT/A,VMX2,VS3
	99101-ZH8-0920	JET, MAIN, #92	(1)	-	-	-----	VKE4,VKX4,VPE4,VPE4/A,VPE5,VPE7,VPE7/A,VPX4,VPX4/A,VPX5,VPX7,VPX7/A,VSD3,VSD3/A,VS37,VS37/A
45	99204-ZE2-0400	JET SET, PILOT, #40	1	-	-	-----	VKE4,VKX4,VPE4,VPE4/A,VPE5,VPE7,VPE7/A,VPX4,VPX4/A,VPX5,VPX7,VPX7/A,VSD3,VSD3/A,VS37,VS37/A
	99204-ZE0-0400		1	-	-	-----	ES3,ES3/A,VKE4,VMS2,VMT,VMT/A,VMX2,VS3
						-----	VKX4,VPE4,VPE4/A,VPE5,VPE7,VPE7/A,VPX4,VPX4/A,VPX5,VPX7,VPX7/A,VSD3,VSD3/A,VS37,VS37/A
46	16015-ZA0-931	CHAMBER SET, FLOAT	1	-	-	-----	ES3,ES3/A,VKE4,VMS2,VMT,VMT/A,VMX2,VS3
47	16024-124-761	SCREW SET, DRAIN	1	-	-	-----	ES3,ES3/A,VMS2,VMT,VMT/A,VMX2,VS3
	16024-124-760	(CARBURETOR NO.)	1	-	-	BE21E B	VKE4
		(CARBURETOR NO.)	1	-	-	BE21E C	VKE4
48	16028-ZA0-931	SCREW SET	1	-	-	-----	ES3,ES3/A,VKE4,VMS2,VMT,VMT/A,VMX2,VS3
49	16230-ZE3-701	VALVE ASSY., SOLENOID	1	-	-	-----	ES3,ES3/A,VKE4,VMS2,VMT,VMT/A,VMX2,VS3
50	90650-SD9-003	CLIP, WIRE HARNESS	1	-	-	-----	ES3,ES3/A,VMT,VMT/A,VS3
51	93892-05012-18	SCREW-WASHER, 5X12	2	-	-	-----	ES3,ES3/A,VKE4,VMS2,VMT,VMT/A,VMX2,VS3
52	16016-ZH8-W01	SCREW SET	1	-	-	-----	VMS2,VMX2,VPE5,VPX5
		(CARBURETOR NO.)	1	-	-	BE21D C	VKX4,VPE4/A,VPE7/A,VPX4/A,VPX7/A,VSD3/A,VS37/A
			1	-	-	BE21E C	VKE4
53	16211-ZE2-000	INSULATOR, CARBURETOR	1	-	-	-----	VMS2,VMX2
54	16260-ZF6-U70	STAY ASSY., MANUAL CHOKE	1	-	-	-----	VMS2,VMX2
55	36170-ZB4-003	VALVE ASSY., SOLENOID	1	-	-	-----	VKE4

E-14-2

CARBURETOR(3)

K10

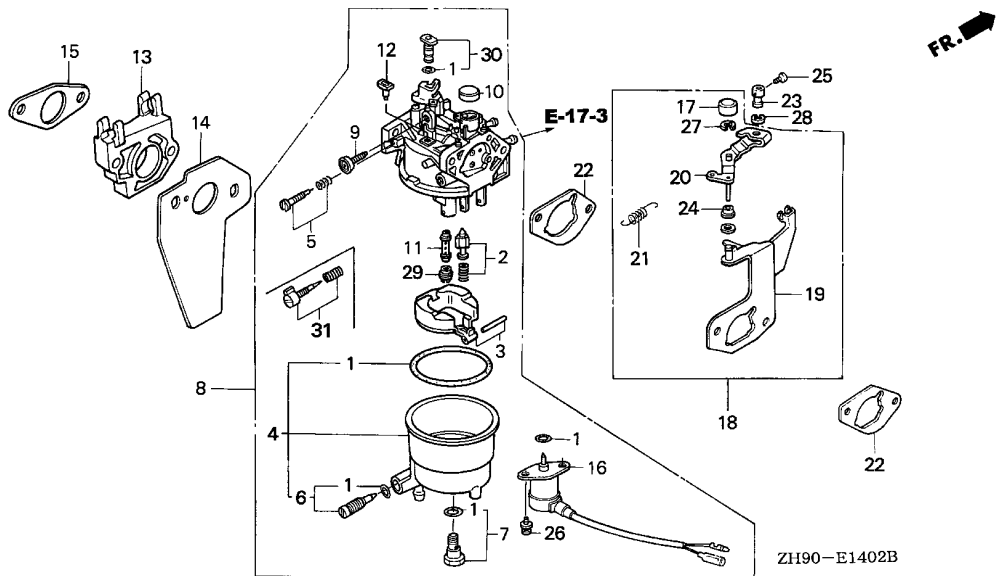

Ref. No.	L.O.N.	(Relative ref. Number) Description	F.R.T.
1	3111G1	GASKET SET, CARBURETOR(A) (3)	0.4
2	3111G6	VALVE SET, FLOAT AND/OR FLOAT SET(A)	0.4
5	3111D7	SCREW SET, PILOT	0.2
8	3111G7	CARBURETOR(A)	0.3
13	3111G2	INSULATOR, CARBURETOR AND/OR PACKING, INSULATOR(A)	0.3
14	3111G5	PACKING, CARBURETOR(A)	0.3
16	6211C0	VALVE, CARBURETOR SOLENOID ...	0.2
19	3111G3	STAY, CHOKE CONTROL	0.2
22	3121D9	PACKING, AIR CLEANER	0.2
29	3111G4	JET, MAIN(A)	0.4

.NOTE: Same time for two units

Ref. No.	Part No.	Description	Reqd. QTY			Serial No.	Parts catalogue code
			(1)	(2)	(3)		
1	16010-ZE3-701	GASKET SET	1	-	-	ESS,ESS/A	
2	16011-ZA0-931	VALVE SET, FLOAT	1	-	-	ESS,ESS/A	
3	16013-ZA0-931	FLOAT SET	1	-	-	ESS,ESS/A	
4	16015-ZA0-931	CHAMBER SET, FLOAT	1	-	-	ESS,ESS/A	
5	16016-ZA0-931	SCREW SET, PILOT	1	-	-	ESS	
		(CARBURETOR NO.)	1	-	-	BE21E B ESS/A	
6	16024-124-761	SCREW SET, DRAIN	1	-	-	ESS	
		(CARBURETOR NO.)	1	-	-	BE21E B ESS/A	
	16024-124-760	1	-	-	BE21E C ESS/A	
		(CARBURETOR NO.)	1	-	-	ESS/A	
7	16028-ZA0-931	SCREW SET	1	-	-	ESS,ESS/A	
8	16100-ZH9-V10	CARBURETOR ASSY. (BE21E A) ..	1	-	-	1175523 ESS	
	16100-ZH9-V11	CARBURETOR ASSY. (BE21E B) ..	1	-	-	1175524 ESS	
		1	-	-	2341615 ESS/A	
	16100-ZH9-V12	CARBURETOR ASSY. (BE21E C) ..	1	-	-	2341616 ESS/A	
9	16124-ZE0-005	SCREW, THROTTLE STOP	1	-	-	ESS,ESS/A	
10	16148-141-881	CAP, CHOKE DUST	1	-	-	ESS,ESS/A	
11	16166-ZH9-820	NOZZLE, MAIN	1	-	-	ESS,ESS/A	
12	16172-ZE3-W10	COLLAR, SETTING	1	-	-	ESS,ESS/A	
13	16211-ZB7-000	INSULATOR, CARBURETOR	1	-	-	ESS,ESS/A	
14	16221-ZB7-800	PACKING, CARBURETOR	1	-	-	ESS,ESS/A	
15	16223-ZA0-800	PACKING, INSULATOR	1	-	-	ESS,ESS/A	
16	16230-ZE3-701	VALVE ASSY., SOLENOID	1	-	-	ESS,ESS/A	
17	16252-ZA1-010	CAP, CHOKE LEVER	1	-	-	ESS,ESS/A	
18	16260-ZB7-702	STAY ASSY., REMOTE CHOKE	1	-	-	ESS,ESS/A	
19	16261-ZB7-700	STAY COMP., REMOTE CHOKE	1	-	-	ESS,ESS/A	

2

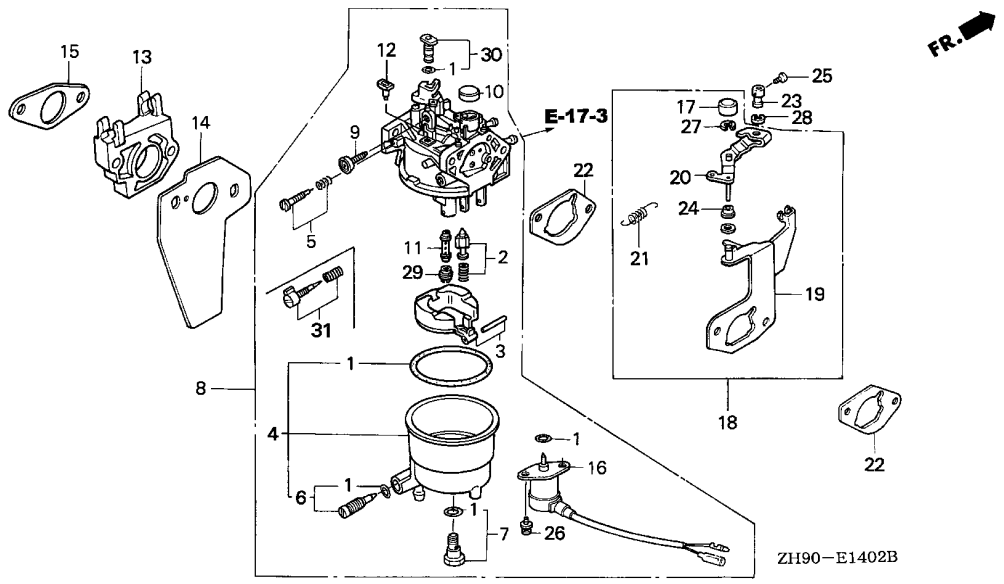

Ref. No.	Part No.	Description	Reqd. QTY			Serial No.	Parts catalogue code
			(1)	(2)	(3)		
20	16263-ZB7-701	LEVER, REMOTE CHOKE	1	-	-	-----	ESS,ESS/A
21	16268-893-000	SPRING, CHOKE RETURN	1	-	-	-----	ESS,ESS/A
22	16269-ZA0-800	PACKING, AIR CLEANER	2	-	-	-----	ESS,ESS/A
23	16617-890-010	HOLDER, CABLE	1	-	-	-----	ESS,ESS/A
24	91502-ZB7-700	BUSH, CHOKE LEVER	1	-	-	-----	ESS,ESS/A
25	93500-04008-0A	SCREW, PAN, 4X8	1	-	-	-----	ESS,ESS/A
26	93892-05012-18	SCREW-WASHER, 5X12	2	-	-	-----	ESS,ESS/A
27	94540-04018	E-RING, 4MM	1	-	-	-----	ESS,ESS/A
28	94540-05010	E-RING, 5MM	1	-	-	-----	ESS,ESS/A
29	99101-ZH8-0880	JET, MAIN, #88	(1)	-	-	-----	ESS,ESS/A
	99101-ZH8-0900	JET, MAIN, #90	(1)	-	-	-----	ESS,ESS/A
	99101-ZH8-0920	JET, MAIN, #92	1	-	-	-----	ESS,ESS/A
30	99204-ZE2-0400	JET SET, PILOT, #40	1	-	-	-----	ESS,ESS/A
31	16016-ZH8-W01	SCREW SET	1	-	-	BE21E C -----	ESS/A
		(CARBURETOR NO.)					

E-14-3

CARBURETOR(4)

K12

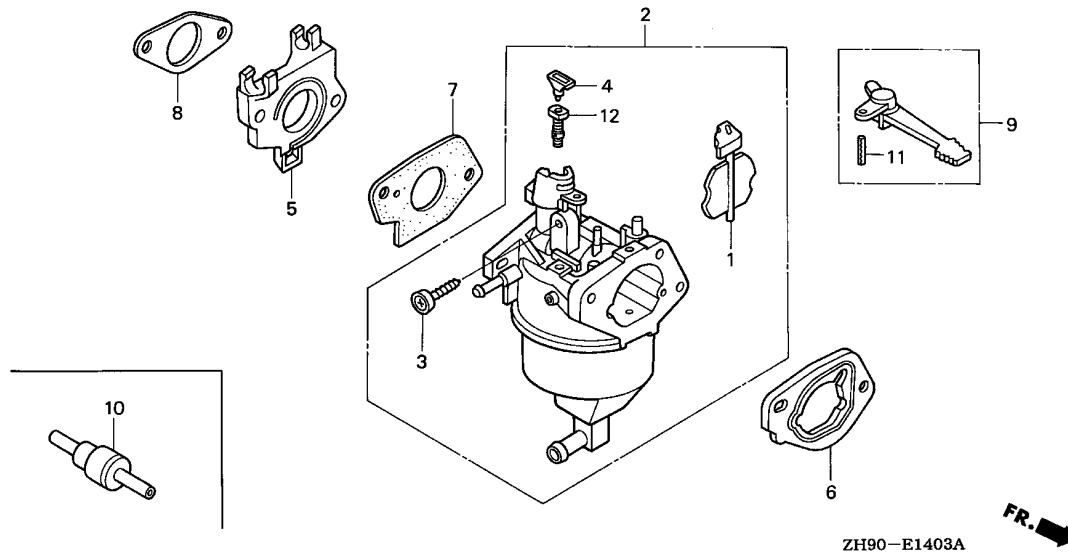

Ref. No.	L.O.N.	(Relative ref. Number) Description	F.R.T.
1	8101C5	CHOKE SET, CARBURETOR	0.2
2	3111F3	CARBURETOR	0.2
5	3111C0	(8) INSULATOR, CARBURETOR AND/OR PACKING, INSULATOR	0.2
6	3111D9	SPACER, CARBURETOR	0.2
7	3111C8	PACKING, CARBURETOR	0.2
9	8101F9	LEVER, CARBURETOR CHOKE	0.2
10	311175	VALVE, DASHPOT CHECK	0.1

Ref. No.	Part No.	Description	Reqd. QTY			Serial No.	Parts catalogue code
			(1)	(2)	(3)		
1	16044-ZH9-831	CHOKE SET	-	-	1		
2	16100-ZH9-831	CARBURETOR ASSY. (BEL3A A) ..	-	-	1		
3	16124-ZE0-005	SCREW, THROTTLE STOP	-	-	1		
4	16172-ZE3-W10	COLLAR, SETTING	-	-	1		
5	16211-ZE2-000	INSULATOR, CARBURETOR	-	-	1		
6	16220-ZA0-702	SPACER COMP., CARBURETOR	-	-	1		
7	16221-ZA0-800	PACKING, CARBURETOR	-	-	1		
8	16223-ZA0-800	PACKING, INSULATOR	-	-	1		
9	16610-ZE1-000	LEVER COMP., CHOKE (STD.) ...	-	-	1		
10	36135-PH3-004	VALVE, DASHPOT CHECK	-	-	(1)	-----	HAP,HAP/A,VXP,VXP/A,VXQP
11	94305-20122	PIN, SPRING, 2X12	-	-	1		
12	99104-ZE0-0450	JET, PILOT, #45	-	-	1		

2

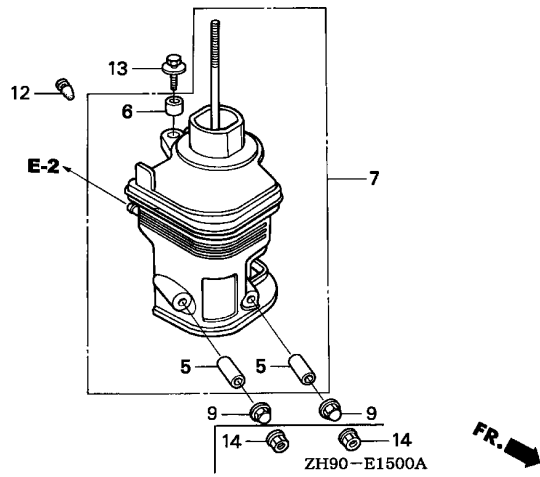
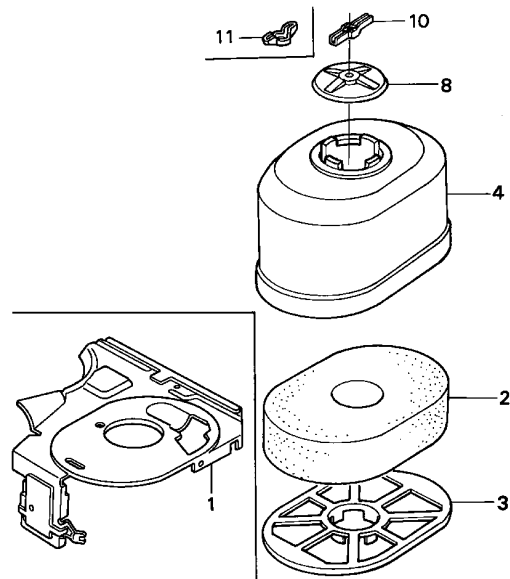

Ref. No.	L.O.N.	(Relative ref. Number) Description	F.R.T.
1	4141J6	COVER, AIR CLEANER CONTROL ... (3)	0.1
2	3121B8	ELEMENT, AIR CLEANER	0.1
7	3121B4	ELBOW, AIR CLEANER	0.1

Ref. No.	Part No.	Description	Reqd. QTY			Serial No.	Parts catalogue code
			(1)	(2)	(3)		
1	16591-ZE2-P51	COVER, CONTROL	1	-	-	LWD	
2	17211-ZE2-000	ELEMENT, AIR CLEANER (SEMI DRY)	1	-	-	LJ,LJ/A,LJC,LJC/A,LJG,LJG/A,QD,QD/A,RD,RD/A,SD,SD/A,SJ,SJ/A,SJG,SJG/A,SJP,SK,SKE1,SN,SN/A	
3	17212-ZE2-000	GRID, AIR CLEANER	-	(1)	-	LJ,LJ/A,LJC,LJC/A,LJG,LJG/A,QD,QD/A,RD,RD/A,SD,SD/A,SJ,SJ/A,SJG,SJG/A,SJP,SK,SKE1,SN,SN/A	
4	17231-ZE2-000	COVER, AIR CLEANER (SEMI DRY)	1	-	-	LJ,LJ/A,LJC,LJC/A,LJG,LJG/A,LWD,QD,QD/A,RD,RD/A,SD,SD/A,SJ,SJ/A,SJG,SJG/A,SJP,SK,SKE1,SN,SN/A	
5	17238-ZE2-310	COLLAR, AIR CLEANER	2	-	-	LJ,LJ/A,LJC,LJC/A,LJG,LJG/A,LWD,QD,QD/A,RD,RD/A,SD,SD/A,SJ,SJ/A,SJG,SJG/A,SJP,SK,SKE1,SN,SN/A	
6	17239-ZE1-000	COLLAR B, AIR CLEANER	1	-	-	LJ,LJ/A,LJC,LJC/A,LJG,LJG/A,LWD,QD,QD/A,RD,RD/A,SD,SD/A,SJ,SJ/A,SJG,SJG/A,SJP,SK,SKE1,SN,SN/A	
7	17410-ZE2-020	ELBOW COMP., AIR CLEANER	1	-	-	LJ,LJ/A,LJC,LJC/A,LJG,LJG/A,LWD,QD,QD/A,RD,RD/A,SD,SD/A,SJ,SJ/A,SJG,SJG/A,SJP,SK,SKE1,SN,SN/A	
8	17420-ZE2-000	CAP COMP., AIR CLEANER	1	-	-	LJ,LJ/A,LJC,LJC/A,LJG,LJG/A,QD,QD/A,RD,RD/A,SD,SD/A,SJ,SJ/A,SJG,SJG/A,SJP,SK,SKE1,SN,SN/A	
	17420-ZE2-P50	1	-	-	LWD	
9	90201-415-000	NUT, CAP, 6MM	2	(2)	-	1053526 LJ,L1,QD,Q1,Q2,RD,R1,SD,SJ,SJP,SK,S1,V1,W1	
			2	-	-	1070319 LWD	
10	90203-PB2-000	NUT, AIR CLEANER COVER (DACRO COATING)	1	(1)	-	1034589 LJ,L1,QD,Q1,RD,R1,SD,SJ,SJP,SK,S1,V1,W1	

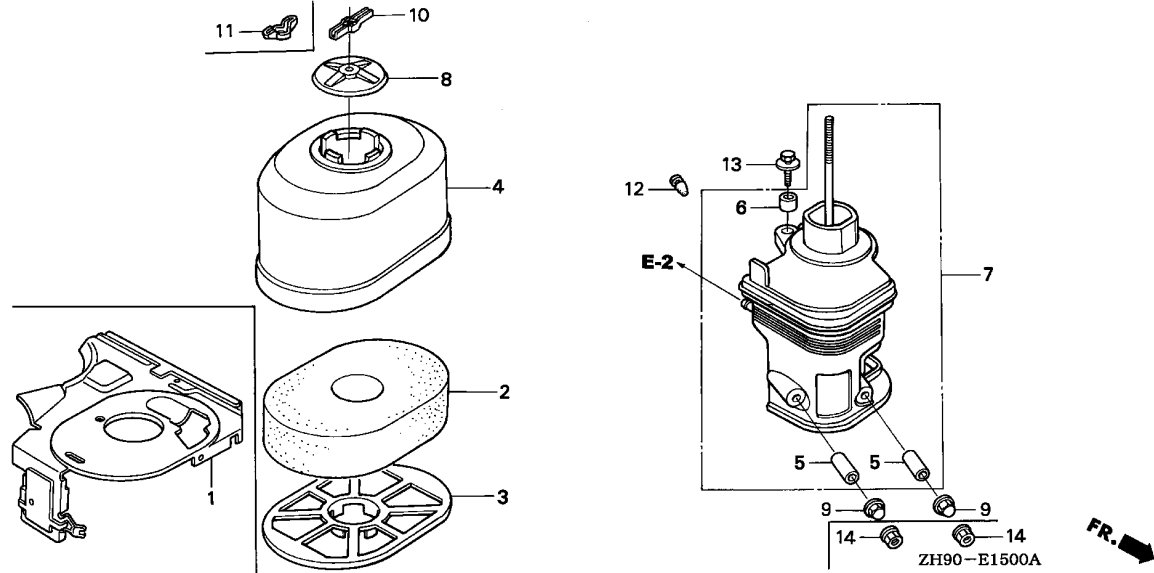

Ref. No.	Part No.	Description	Reqd. QTY			Serial No.	Parts catalogue code
			(1)	(2)	(3)		
10)	90301-ZV0-000	NUT, WING	1	-	-	1097920	LWD
	90203-ZA0-800	NUT, WING, 6MM(BLACK)	1	(1)	-	1094660	Q2,SN
			1	(1)	-	1034590	1094660 LJ,L1,QD,Q1,RD,R1,SD,SJ,SJP,SK,S1,V1,W1
11	90325-044-000	NUT, TOOL BOX SETTING	1	(1)	-	-	LJ/A,LJC,LJC/A,LJG,LJG/A,L1/A,QD/A,Q1/A,RD/A,R1/A,SD/A,SJ/A,SJG
			1	(1)	-	1094661	SJG/A,SKE1,SN/A,S1/A,W1/A
			1	-	-	1097921	LJ,L1,QD,Q1,Q2,RD,R1,SD,SJ,SJP,SK,SN,S1,V1,W1
12	90899-422-610	PLUG, CONE TYPE	1	-	-	-	LWD
13	93494-06020-08	BOLT-WASHER, 6X20	1	(1)	-	-	LJ,QD,RD,SD,SJ,SJP,SK,V1
	93404-06020-08	-	1	-	-	Q2
	90009-ZE2-003	BOLT-WASHER, 6X22	1	1	-	-	LJ/A,LJC,LJC/A,LJG,LJG/A,L1,L1/A,QD/A,Q1,Q1/A,RD/A,R1,R1/A,SD/A
	95701-06035-08	BOLT, FLANGE, 6X35	1	-	-	-	SJ/A,SJG,SJG/A,SKE1,SN,SN/A,S1,S1/A,W1,W1/A
14	94050-06000	NUT, FLANGE, 6MM	2	(2)	-	-	LWD
			2	(2)	-	-	LJ/A,LJC,LJC/A,LJG,LJG/A,L1/A,QD/A,Q1/A,RD/A,R1/A,SD/A,SJ/A,SJG
			2	(2)	-	1053527	SJG/A,SKE1,SN,SN/A,S1/A,W1/A
			2	-	-	1070320	LJ,L1,QD,Q1,Q2,RD,R1,SD,SJ,SJP,SK,S1,V1,W1
							LWD



E-15-1

AIR CLEANER(2)

K15

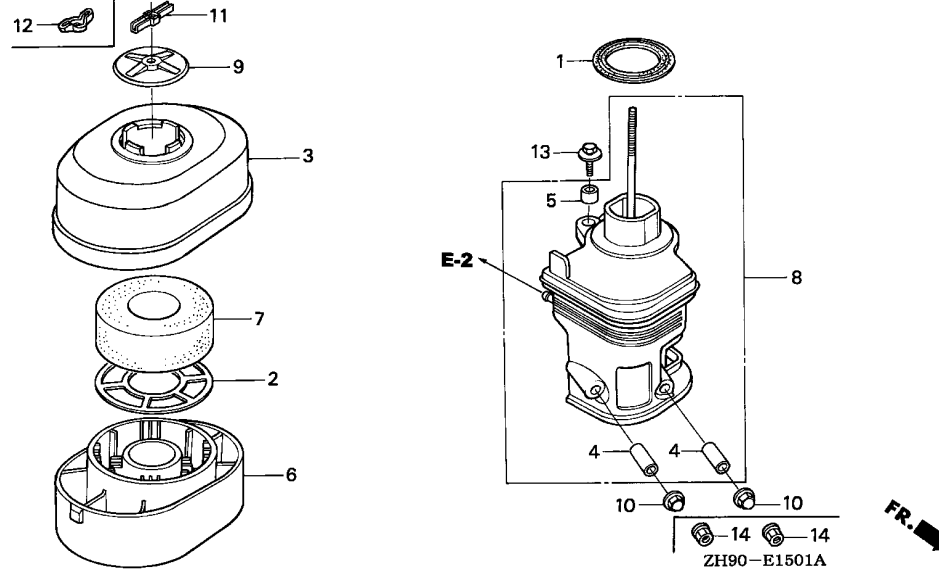

Ref. No.	L.O.N.	(Relative ref. Number) Description	F.R.T.
6	3121E5	PAN, AIR CLEANER OIL	0.1
7		(2)	
	3121B8	ELEMENT, AIR CLEANER	0.1
8	3121B4	ELBOW, AIR CLEANER	0.1

Ref. No.	Part No.	Description	Reqd. QTY			Serial No.	Parts catalogue code
			(1)	(2)	(3)		
1	16271-ZE2-000	PACKING, ELBOW	1	(1)	-	LT,LW,L1,QP,QT,Q1,Q2,R1,SW,SWE,S1,V1,W1	
	16271-ZE2-010	1	-	-	1274336 SMD	
2	17212-ZE2-810	GRID, AIR CLEANER (OIL BATH)	1	(1)	-	LT/A,LW/A,L1/A,QP/A,QT/A,Q1/A,R1/A,S1/A,W1/A	
			1	-	-	LSS,LT,LT/A,LW,LW/A,QP,QP/A,QT,QT/A,SW,SWE	
			-	(1)	-	1274336 SMD	
3	17231-ZE2-810	COVER, AIR CLEANER (OIL BATH)	1	-	-	LSS,LT,LT/A,LW,LW/A,QP,QP/A,QT,QT/A,SW,SWE	
			1	-	-	1274336 SMD	
4	17238-ZE2-310	COLLAR, AIR CLEANER	2	(1)	-	LSS,LT,LT/A,LW,LW/A,QP,QP/A,QT,QT/A,SW,SWE	
			2	-	-	1274336 SMD	
5	17239-ZE1-000	COLLAR B, AIR CLEANER	1	(2)	-	LSS,LT,LT/A,LW,LW/A,QP,QP/A,QT,QT/A,SW,SWE	
			1	-	-	1274336 SMD	
			-	(1)	-		
6	17402-ZE2-810	PAN, CLEANER OIL (OIL BATH) -	1	-	-	LSS,LT,LT/A,LW,LW/A,QP,QP/A,QT,QT/A,SW,SWE	
			1	-	-	1274336 SMD	
7	17403-ZE2-810	ELEMENT, AIR CLEANER (OIL BATH)	1	(1)	-	LSS,LT,LT/A,LW,LW/A,QP,QP/A,QT,QT/A,SW,SWE	
			1	-	-	1274336 SMD	
8	17410-ZE2-020	ELBOW COMP., AIR CLEANER	1	(1)	-	LSS,LT,LT/A,LW,LW/A,QP,QP/A,QT,QT/A,SW,SWE	
			1	-	-	1274336 SMD	
			-	(1)	-		
9	17420-ZE2-000	CAP COMP., AIR CLEANER	1	-	-	LSS,LT,LT/A,LW,LW/A,QP,QP/A,QT,QT/A,SW,SWE	
			1	-	-	1274336 SMD	
			-	(1)	-		

2

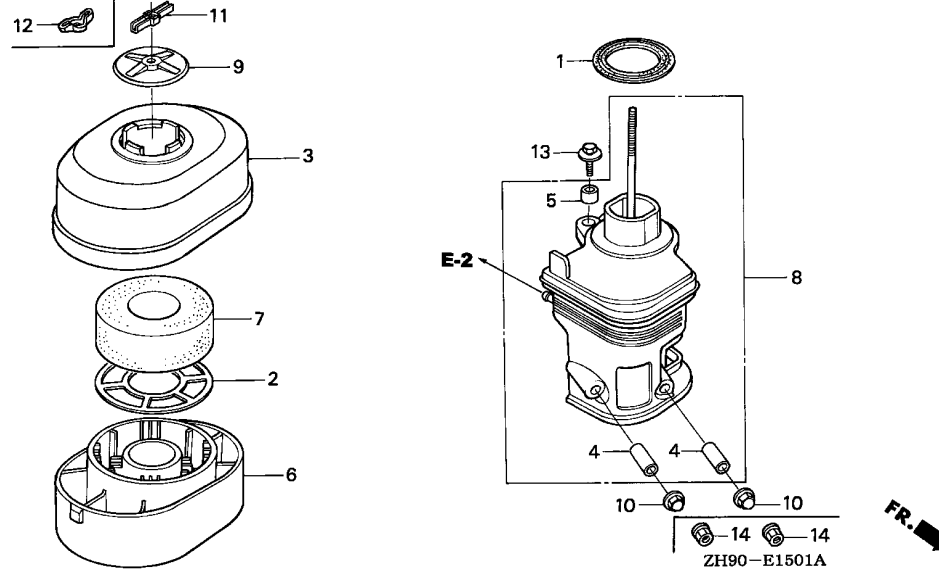

Ref. No.	Part No.	Description	Reqd. QTY			Serial No.	Parts catalogue code
			(1)	(2)	(3)		
10	90201-415-000	NUT, CAP, 6MM	2	(2)	-	1053526 LW,L1,QP,Q1,Q2,R1,SW,SWE,S1,V1,W1	
11	90203-PB2-000	NUT, AIR CLEANER COVER (DACRO COATING)	1	(1)	-	1034589 LW,L1,QP,Q1,R1,SW,SWE,S1,V1,W1	
	90203-ZA0-800	NUT, WING, 6MM(BLACK)	1	(1)	-	1034590 1094660 LW,L1,QP,Q1,R1,SW,SWE,S1,V1,W1	
			-	(1)	-	1094660 Q2	
12	90325-044-000	NUT, TOOL BOX SETTING	1	(1)	-	LSS,LT,LT/A,LW/A,L1/A,QP/A,QT,QT/A,Q1/A,R1/A,S1/A,W1/A	
			1	(1)	-	1094661 LW,L1,QP,Q1,Q2,R1,SW,SWE,S1,V1,W1	
			1	-	-	1274336 SMD	
13	93494-06020-08	BOLT-WASHER, 6X20	1	(1)	-	LW,SW,SWE,V1	
	93404-06020-08	1	1	-	LSS,Q2	
			1	-	-	1274336 SMD	
	90009-ZE2-003	BOLT-WASHER, 6X22	1	1	-	LT,LT/A,LW/A,L1,L1/A,QP,QP/A,QT,QT/A,Q1,Q1/A,R1,R1/A,S1,S1/A,W1/A	
14	94050-06000	NUT, FLANGE, 6MM	2	(2)	-	LSS,LT,LT/A,LW/A,L1/A,QP/A,QT,QT/A,Q1/A,R1/A,S1/A,W1/A	
			2	(2)	-	1053527 LW,L1,QP,Q1,Q2,R1,SW,SWE,S1,V1,W1	
			2	-	-	1274336 SMD	



E-15-2

AIR CLEANER(3)

L 1

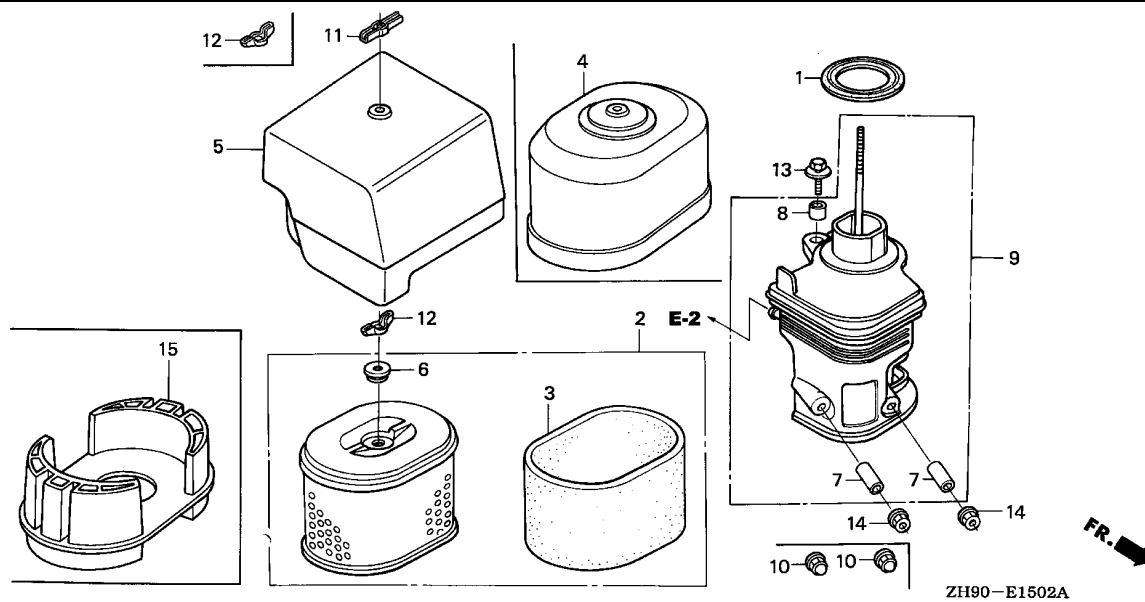

Ref. No.	L.O.N.	(Relative ref. Number) Description	F.R.T.
1	3121E1	PACKING, ELBOW	0.1
2	3121B8	ELEMENT, AIR CLEANER	0.1
3	3121C1	FILTER, OUTER	0.1
9	3121B4	ELBOW, AIR CLEANER	0.1
15	3121D6	NOSE, SILENCER	0.1

Ref. No.	Part No.	Description	Reqd. QTY			Serial No.	Parts catalogue code	
			(1)	(2)	(3)			
1	16271-ZE2-000	PACKING, ELBOW	1	(1)	1	-----	ES1, HA, HAP, HAQ, HA2, HEA, HEA2, HEA8, HH, HX, HXQ4, HX26, HX8, LH, LHB1, LHB3, LHE, LHQ4, LWD1, LX, LXE, LXE8, LXQ4, LXU, LXZ, LX16, L1, PA, PAE2, PA2, PX, PXE8, PXU, PX26, QA, QAB1, QAB3, QAE, QAE2, QAE6, QAG, QAG2, QAQ, QAQ4, QAR2, QAW, QA2, QE, QH, QHE, QHE4, QHP1, QHQ4, QHR, QHR4, QHZ, QH26, QKE3, QL2, QME2, QMH, QSE, QSE8, QX, QXB6, QXE, QXE4, QXE6, QXE8, QXQ4, QXU, QX26, Q1, Q2, RA, RA2, RH, RHE, RHE4, RHQ4, RH26, RSC2, RSS, RX, RXP, RXQ4, RXU, R1, SE, SH, SHE, SHEZ, SHQ4, SMC4, SME1, SME6, SWC4, SX, SXE, SXE4, SXE8, SXQ4, SXU, SX2, S1, VA, VAG2, VAW, VAW1, VA2, VDE, VDE2, VH, VKB2, VME2, VM2, VNT2, VWA, VWA2, VWN2, VW12, VW22, VX, VXE, VXE4, VXE6, VXP, VXQP, VXQ4, VXT1, VXU, VXU1, VX26, V1, WMT8, WXE8, W1	
			1	-	-	1274337	-----	SMD
	16271-ZE2-010	(1)	-	-	-----	-----	QD, RD, SD
			1	(1)	1	-----	-----	ES1/A, HAP/A, HA2/A, HEA2/A, HEA8/A, HX/A, HXQ4/A, HX26/A, HX8/A, LH/A, LHB5, LHE/A, LWD1/A, LX/A, LXE/A, LXE8/A, LXQ4/A, LXU/A, L1/A, PAE2/A, PA2/A, PX/A, PXE8/A, PXU/A, PX26/A, QAB3/A, QAE2/A, QAE6/A, QAG/A, QAG2/A, QAQ4/A, QAR2/A, QAW/A, QA2/A, QE/A, QH/A, QHB5, QHE4/A, QHP1/A, QHQ4/A, QHR/A, QHR4/A, QHZ/A, QH26/A, QKE3/A, QKE4, QME2/A, QMH/A, QSE/A, QSE2, QSE8/A, QX/A, QXB6/A, QXE/A, QXE4/A, QXE6/A, QXE8/A, QXQ4/A, QXU/A, QX26/A, Q1/A, RA2/A, RHE4/A, RHQ4/A, RH26/A, RSC2/A, RSS/A, RX/A, RXP/A, RXQ4/A, RXU/A, R1/A, SE/A, SH/A, SHQ4/A, SMC4/A, SME1/A, SME6/A, SMX2, SWA4, SWC4/A, SX/A, SXE/A, SXE4/A, SXE8/A, SXQ4/A, SXU/A, S1/A, VAG2/A, VA2/A, VDE2/A, VKB2/A, VME2/A, VM2/A, VNT2/A, VWA2/A, VWN2/A, VW12/A, VX/A, VXE4/A, VXE6/A, VXP/A, VXQ4/A, VXT1/A, VXU/A, VXU1/A, WMA4, WMT8/A, WXE8/A, W1/A
			(1)	-	-	-----	-----	QD/A, RD/A, SD/A

Ref. No.	Part No.	Description	Reqd. QTY			Serial No.	Parts catalogue code
			(1)	(2)	(3)		
2	17210-ZE2-822	ELEMENT, AIR CLEANER (DUAL) -	1	-	-	-----	ES1,ES1/A,HA,HAQ,HA2,HA2/A,HEA,HEA2,HEA2/A,HEA8,HEA8/A,HH,HX,HX/A,HXQ4,HXQ4/A,HX26,HX26/A,HX8,HX8/A,LH,LH/A,LHB1,LHB3,LHB5,LHE,LHE/A,LHQ4,LWD1,LWD1/A,LX,LX/A,LXE,LXE/A,LXE8,LXE8/A,LXQ4,LXQ4/A,LXU,LXU/A,LXZ,LX16,PA,PAE2,PAE2/A,PA2,PA2/A,PX,PX/A,PXE8,PXE8/A,PXU,PXU/A,PX26,PX26/A,QA,QAB1,QAB3,QAB3/A,QAE,QAE2,QAE2/A,QAE6,QAE6/A,QAG,QAG/A,QAG2,QAG2/A,QAQ,QAQ4,QAQ4/A,QAR2,QAR2/A,QAW,QAW/A,QA2,QA2/A,QE,QE/A,QH,QH/A,QHB5,QHE,QHE4,QHE4/A,QHP1,QHP1/A,QHQ4,QHQ4/A,QHR,QHR/A,QHR4,QHR4/A,QHZ,QHZ/A,QH26,QH26/A,QKE3,QKE3/A,QKE4,QL2,QME2,QME2/A,QMH,QMH/A,QSE,QSE/A,QSE2,QSE8,QSE8/A,QX,QX/A,QXB6,QXB6/A,QXE,QXE/A,QXE4,QXE4/A,QXE6,QXE6/A,QXE8,QXE8/A,QXQ4,QXQ4/A,QXU,QXU/A,QX26,QX26/A,RA,RA2,RA2/A,RH,RHE,RHE4,RHE4/A,RHQ4,RHQ4/A,RH26,RH26/A,RSC2,RSC2/A,RSS,RSS/A,RX,RX/A,RXQ4,RXQ4/A,RXU,RXU/A,SE,SE/A,SH,SH/A,SHE,SHEZ,SHQ4,SHQ4/A,SMC4,SMC4/A,SME1/A,SME6,SME6/A,SMX2,SWA4,SWC4,SWC4/A,SX,SX/A,SXE,SXE/A,SXE4,SXE4/A,SXE8,SXE8/A,SXQ4,SXQ4/A,SXU,SXU/A,SX2,VA,VAG2,VAG2/A,VAW,VAW1,VA2,VA2/A,VDE,VDE2,VDE2/A,VH,VKB2,VKB2/A,VME2,VME2/A,VM2,VM2/A,VNT2,VNT2/A,VWA,VWA2,VWA2/A,VWN2,VWN2/A,VW12,VW12/A,VW22,VX,VX/A,VXE,VXE4,VXE4/A,VXE6,VXE6/A,VXQ4,VXQ4/A,VXT1,VXT1/A,VXU,VXU/A,VXU1,VXU1/A,VX26,WMA4,WMT8,WMT8/A,WXE8,WXE8/A
			1	-	-	1274337	----- SMD
			(1)	-	-	-----	QD,QD/A,RD,RD/A,SD,SD/A
			-	(1)	1		
3	17218-ZE2-821	FILTER, OUTER	1	-	-	-----	ES1,ES1/A,HA,HAQ,HA2,HA2/A,HEA,HEA2,HEA2/A,HEA8,HEA8/A,HH,HX,HX/A,HXQ4,HXQ4/A,HX26,HX26/A,HX8,HX8/A,LH,LH/A,LHB1,LHB3,LHB5,LHE,LHE/A,LHQ4,LWD1,LWD1/A,LX,LX/A,LXE,LXE/A,LXE8,LXE8/A,LXQ4,LXQ4/A,LXU,LXU/A,LXZ,LX16,PA,PAE2,PAE2/A,PA2,PA2/A,PX,PX/A,PXE8,PXE8/A,PXU,PXU/A,PX26,PX26/A,QA,QAB1,QAB3,QAB3/A,QAE,QAE2,QAE2/A,QAE6,QAE6/A,QAG,QAG/A,QAG2,QAG2/A,QAQ,QAQ4,QAQ4/A,QAR2,QAR2/A,QAW,QAW/A,QA2,QA2/A,QE,QE/A,QH,QH/A,QHB5,QHE,QHE4,QHE4/A,QHP1,QHP1/A,QHQ4,QHQ4/A,QHR,QHR/A,QHR4,QHR4/A,QHZ,QHZ/A,QH26,QH26/A,QKE3,QKE3/A,QKE4,QL2,QME2,QME2/A,QMH,QMH/A,QSE,QSE/A,QSE2,QSE8,QSE8/A,QX,QX/A,QXB6,QXB6/A,QXE,QXE/A,QXE4,QXE4/A,QXE6,QXE6/A,QXE8,QXE8/A,QXQ4,QXQ4/A,QXU,QXU/A,QX26,QX26/A,RA,RA2,RA2/A,RH,RHE,RHE4,RHE4/A,RHQ4,RHQ4/A,RH26,RH26/A,RSC2,RSC2/A,RSS,RSS/A,RX,RX/A,RXQ4,RXQ4/A,RXU,RXU/A,SE,SE/A,SH,SH/A,SHE,SHEZ,SHQ4,SHQ4/A,SMC4,SMC4/A,SME1/A,SME6,SME6/A,SMX2,SWA4,SWC4,SWC4/A,SX,SX/A,SXE,SXE/A,SXE4,SXE4/A,SXE8,SXE8/A,SXQ4,SXQ4/A,SXU,SXU/A,SX2,VA,VAG2,VAG2/A,VAW,VAW1,VA2,VA2/A,VDE,VDE2,VDE2/A,VH,VKB2,VKB2/A,VME2,VME2/A,VM2,VM2/A,VNT2,VNT2/A,VWA,VWA2,VWA2/A,VWN2,VWN2/A,VW12,VW12/A,VW22,VX,VX/A,VXE,VXE4,VXE4/A,VXE6,VXE6/A,VXQ4,VXQ4/A,VXT1,VXT1/A,VXU,VXU/A,VXU1,VXU1/A,VX26,WMA4,WMT8,WMT8/A,WXE8,WXE8/A
			1	-	-	1274337	----- SMD
			(1)	-	-	-----	QD,QD/A,RD,RD/A,SD,SD/A
			-	(1)	1		
4	17230-ZE2-820	COVER, AIR CLEANER (DUAL) ...	(1)	-	-	-----	QD,QD/A,RD,RD/A,SD,SD/A
			-	(1)	-		



E-15-2

AIR CLEANER(3)

L 3

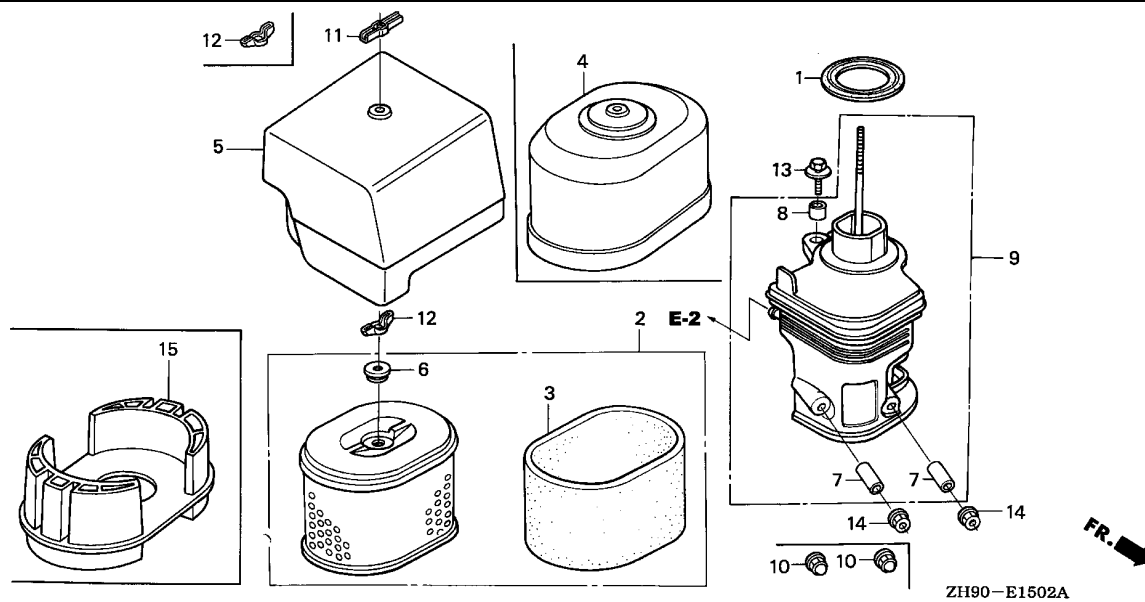

Ref. No.	Part No.	Description	Reqd. QTY			Serial No.	Parts catalogue code				
			(1)	(2)	(3)						
5	17231-ZH9-820	COVER, AIR CLEANER	1	-	-	ES1,ES1/A,HA,HAQ,HA2,HA2/A,HEA,HEA2,HEA2/A,HEA8,HEA8/A,HH,HX,HX/A,HXQ4,HXQ4/A,HX26,HX26/A,HX8,HX8/A,LH,LH/A,LHB1,LHB3,LHB5,LHE,LHE/A,LHQ4,LWD1,LWD1/A,LX,LX/A,LXE,LXE/A,LXE8,LXE8/A,LXQ4,LXQ4/A,LXU,LXU/A,LXZ,LX16,PA,PAE2,PAE2/A,PA2,PA2/A,PX,PX/A,PXE8,PXE8/A,PXU,PXU/A,PX26,PX26/A,QA,QAB1,QAB3,QAB3/A,QAE,QAE2,QAE2/A,QAE6,QAE6/A,QAG,QAG/A,QAG2,QAG2/A,QAQ,QAQ4,QAQ4/A,QAR2,QAR2/A,QAW,QAW/A,QA2,QA2/A,QE,QE/A,QH,QH/A,QHB5,QHE,QHE4,QHE4/A,QHP1,QHP1/A,QHQ4,QHQ4/A,QHR,QHR/A,QHR4,QHR4/A,QHZ,QHZ/A,QH26,QH26/A,QL2,QME2,QME2/A,QMH,QMH/A,QSE,QSE/A,QSE2,QSE8,QSE8/A,QX,QX/A,QXB6,QXB6/A,QXE,QXE/A,QXE4,QXE4/A,QXE6,QXE6/A,QXE8,QXE8/A,QXQ4,QXQ4/A,QXU,QXU/A,QX26,QX26/A,RA,RA2,RA2/A,RH,RHE,RHE4,RHE4/A,RHQ4,RHQ4/A,RH26,RH26/A,RSC2,RSC2/A,RSS,RSS/A,RX,RX/A,RXQ4,RXQ4/A,RXU,RXU/A,SE,SE/A,SH,SH/A,SHE,SHEZ,SHQ4,SHQ4/A,SMC4,SMC4/A,SME1,SME1/A,SME6,SME6/A,SMX2,SWA4,SWC4,SWC4/A,SX,SX/A,SXE,SXE/A,SXE4,SXE4/A,SXE8,SXE8/A,SXQ4,SXQ4/A,SXU,SXU/A,SX2,VA,VAG2,VAG2/A,VAW,VAW1,VA2,VA2/A,VDE,VDE2,VDE2/A,VH,VKB2,VKB2/A,VME2,VME2/A,VM2,VM2/A,VNT2/VNT2/A,VWA,VWA2,VWA2/A,VWN2,VWN2/A,VW12,VW12/A,VW22,VX,VX/A,VXE,VXE4,VXE4/A,VXE6,VXE6/A,VXQ4,VXQ4/A,VXT1,VXT1/A,VXU,VXU/A,VXU1/VXU1/A,VX26,WMA4,WMT8,WMT8/A,WXE8,WXE8/A	1	-	-	1274337	SMD
			-	(1)	1						

Ref. No.	Part No.	Description	Reqd. QTY			Serial No.	Parts catalogue code
			(1)	(2)	(3)		
6	17232-891-000	GROMMET, AIR CLEANER	1	-	-	-----	ES1,ES1/A,HA,HAQ,HA2,HA2/A,HEA,HEA2,HEA2/A,HEA8,HEA8/A,HH,HX,HX/A,HXQ4,HXQ4/A,HX26,HX26/A,HX8,HX8/A,LH,LH/A,LHB1,LHB3,LHB5,LHE,LHE/A,LHQ4,LWD1,LWD1/A,LX,LX/A,LXE,LXE/A,LXE8,LXE8/A,LXQ4,LXQ4/A,LXU,LXU/A,LXZ,LX16,PA,PAE2,PAE2/A,PA2,PA2/A,PX,PX/A,PXE8,PXE8/A,PXU,PXU/A,PX26,PX26/A,QA,QAB1,QAB3,QAB3/A,QAE,QAE2,QAE2/A,QAE6,QAE6/A,QAG,QAG/A,QAG2,QAG2/A,QAQ,QAQ4,QAQ4/A,QAR2,QAR2/A,QAW,QAW/A,QA2,QA2/A,QE,QE/A,QH,QH/A,QHB5,QHE,QHE4,QHE4/A,QHP1,QHP1/A,QHQ4,QHQ4/A,QHR,QHR/A,QHR4,QHR4/A,QHZ,QHZ/A,QH26,QH26/A,QKE3,QKE3/A,QKE4,QKE4,A,QME2,QME2/A,QMH,QMH/A,QSE,QSE/A,QSE2,QSE8,QSE8/A,QX,QX/A,QXB6,QXB6/A,QXE,QXE/A,QXE4,QXE4/A,QXE6,QXE6/A,QXE8,QXE8/A,QXQ4,QXQ4/A,QXU,QXU/A,QX26,QX26/A,RA,RA2,RA2/A,RH,RHE,RHE4,RHE4/A,RHQ4,RHQ4/A,RH26,RH26/A,RSC2,RSC2/A,RSS,RSS/A,RX,RX/A,RXQ4,RXQ4/A,RXU,RXU/A,SE,SE/A,SH,SH/A,SHE,SHEZ,SHQ4,SHQ4/A,SMC4,SMC4/A,SME1/A,SME6,SME6/A,SMX2,SWA4,SWC4,SWC4/A,SX,SX/A,SXE,SXE/A,SXE4,SXE4/A,SXE8,SXE8/A,SXQ4,SXQ4/A,SXU,SXU/A,SX2,VA,VAG2,VAG2/A,VAW,VAW1,VA2,VA2/A,VDE,VDE2,VDE2/A,VH,VKB2,VKB2/A,VME2,VME2/A,VM2,VM2/A,VNT2,VNT2/A,VWA,VWA2,VWA2/A,VWN2,VWN2/A,VW12,VW12/A,VW22,VX,VX/A,VXE,VXE4,VXE4/A,VXE6,VXE6/A,VXQ4,VXQ4/A,VXT1,VXT1/A,VXU,VXU/A,VXU1,VXU1/A,VX26,WMA4,WMT8,WMT8/A,WXE8,WXE8/A
			1	-	-	1274337	SMD
			(1)	-	-	-----	QD,QD/A,RD,RD/A,SD,SD/A
			-	(1)	1		
7	17238-ZE2-310	COLLAR, AIR CLEANER	2	-	-	-----	ES1,ES1/A,HA,HAQ,HA2,HA2/A,HEA,HEA2,HEA2/A,HEA8,HEA8/A,HH,HX,HX/A,HXQ4,HXQ4/A,HX26,HX26/A,HX8,HX8/A,LH,LH/A,LHB1,LHB3,LHB5,LHE,LHE/A,LHQ4,LWD1,LWD1/A,LX,LX/A,LXE,LXE/A,LXE8,LXE8/A,LXQ4,LXQ4/A,LXU,LXU/A,LXZ,LX16,PA,PAE2,PAE2/A,PA2,PA2/A,PX,PX/A,PXE8,PXE8/A,PXU,PXU/A,PX26,PX26/A,QA,QAB1,QAB3,QAB3/A,QAE,QAE2,QAE2/A,QAE6,QAE6/A,QAG,QAG/A,QAG2,QAG2/A,QAQ,QAQ4,QAQ4/A,QAR2,QAR2/A,QAW,QAW/A,QA2,QA2/A,QE,QE/A,QH,QH/A,QHB5,QHE,QHE4,QHE4/A,QHP1,QHP1/A,QHQ4,QHQ4/A,QHR,QHR/A,QHR4,QHR4/A,QHZ,QHZ/A,QH26,QH26/A,QKE3,QKE3/A,QKE4,QKE4,A,QME2,QME2/A,QMH,QMH/A,QSE,QSE/A,QSE2,QSE8,QSE8/A,QX,QX/A,QXB6,QXB6/A,QXE,QXE/A,QXE4,QXE4/A,QXE6,QXE6/A,QXE8,QXE8/A,QXQ4,QXQ4/A,QXU,QXU/A,QX26,QX26/A,RA,RA2,RA2/A,RH,RHE,RHE4,RHE4/A,RHQ4,RHQ4/A,RH26,RH26/A,RSC2,RSC2/A,RSS,RSS/A,RX,RX/A,RXQ4,RXQ4/A,RXU,RXU/A,SE,SE/A,SH,SH/A,SHE,SHEZ,SHQ4,SHQ4/A,SMC4,SMC4/A,SME1/A,SME6,SME6/A,SMX2,SWA4,SWC4,SWC4/A,SX,SX/A,SXE,SXE/A,SXE4,SXE4/A,SXE8,SXE8/A,SXQ4,SXQ4/A,SXU,SXU/A,SX2,VA,VAG2,VAG2/A,VAW,VAW1,VA2,VA2/A,VDE,VDE2,VDE2/A,VH,VKB2,VKB2/A,VME2,VME2/A,VM2,VM2/A,VNT2,VNT2/A,VWA,VWA2,VWA2/A,VWN2,VWN2/A,VW12,VW12/A,VW22,VX,VX/A,VXE,VXE4,VXE4/A,VXE6,VXE6/A,VXQ4,VXQ4/A,VXT1,VXT1/A,VXU,VXU/A,VXU1,VXU1/A,VX26,WMA4,WMT8,WMT8/A,WXE8,WXE8/A
			2	-	-	1274337	SMD
			(2)	-	-	-----	QD,QD/A,RD,RD/A,SD,SD/A
			-	(2)	2		



E-15-2

AIR CLEANER(3)

L 5

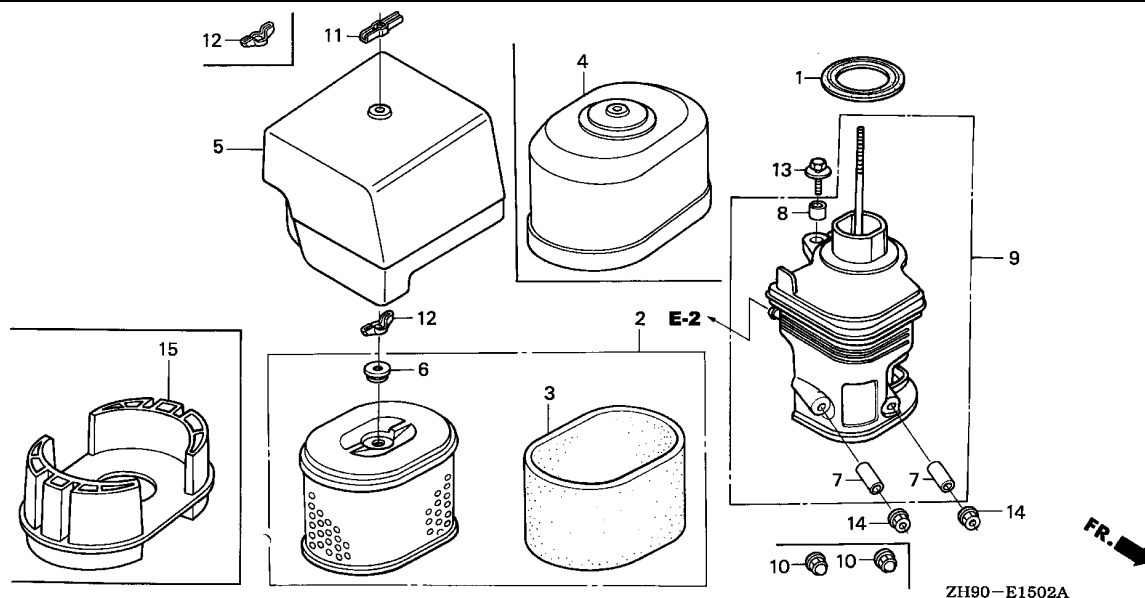

Ref. No.	Part No.	Description	Reqd. QTY			Serial No.	Parts catalogue code
			(1)	(2)	(3)		
8	17239-ZE1-000	COLLAR B, AIR CLEANER	1	-	-	-----	ES1,ES1/A,HA,HAQ,HA2,HA2/A,HEA,HEA2,HEA2/A,HEA8,HEA8/A,HH,HX,HX/A,HXQ4,HXQ4/A,HX26,HX26/A,HX8,HX8/A,LH,LH/A,LHB1,LHB3,LHB5,LHE,LHE/A,LHQ4,LWD1,LWD1/A,LX,LX/A,LXE,LXE/A,LXE8,LXE8/A,LXQ4,LXQ4/A,LXU,LXU/A,LXZ,LX16,PA,PAE2,PAE2/A,PA2,PA2/A,PX,PX/A,PXE8,PXE8/A,PXU,PXU/A,PX26,PX26/A,QA,QAB1,QAB3,QAB3/A,QAE,QAE2,QAE2/A,QAE6,QAE6/A,QAG,QAG/A,QAG2,QAG2/A,QAQ,QAQ4,QAQ4/A,QAR2,QAR2/A,QAW,QAW/A,QA2,QA2/A,QE,QE/A,QH,QH/A,QHB5,QHE,QHE4,QHE4/A,QHP1,QHP1/A,QHQ4,QHQ4/A,QHR,QHR/A,QHR4,QHR4/A,QHZ,QHZ/A,QH26,QH26/A,QKE3,QKE3/A,QKE4,QL2,QME2,QME2/A,QMH,QMH/A,QSE,QSE/A,QSE2,QSE8,QSE8/A,QX,QX/A,QXB6,QXB6/A,QXE,QXE/A,QXE4,QXE4/A,QXE6,QXE6/A,QXE8,QXE8/A,QXQ4,QXQ4/A,QXU,QXU/A,QX26,QX26/A,RA,RA2,RA2/A,RH,RHE,RHE4,RHE4/A,RHQ4,RHQ4/A,RH26,RH26/A,RSC2,RSC2/A,RSS,RSS/A,RX,RX/A,RXQ4,RXQ4/A,RXU,RXU/A,SE,SE/A,SH,SH/A,SHE,SHEZ,SHQ4,SHQ4/A,SMC4,SMC4/A,SME1,SME1/A,SME6,SME6/A,SMX2,SWA4,SWC4,SWC4/A,SX,SX/A,SXE,SXE/A,SXE4,SXE4/A,SXE8,SXE8/A,SXQ4,SXQ4/A,SXU,SXU/A,SX2,VA,VAG2,VAG2/A,VAW,VAW1,VA2,VA2/A,VDE,VDE2,VDE2/A,VH,VKB2,VKB2/A,VME2,VME2/A,VM2,VM2/A,VNT2,VNT2/A,VWA,VWA2,VWA2/A,VWN2,VWN2/A,VW12,VW12/A,VW22,VX,VX/A,VXE,VXE4,VXE4/A,VXE6,VXE6/A,VXQ4,VXQ4/A,VXT1,VXT1/A,VXU,VXU/A,VXU1,VXU1/A,VX26,WMA4,WMT8,WMT8/A,WXE8,WXE8/A
			1	-	-	1274337	SMD
			(1)	-	-	-----	QD,QD/A,RD,RD/A,SD,SD/A
			-	(1)	1		

Ref. No.	Part No.	Description	Reqd. QTY			Serial No.	Parts catalogue code
			(1)	(2)	(3)		
9	17410-ZE2-020	ELBOW COMP., AIR CLEANER	1	-	-	-----	ES1,ES1/A,HA,HAQ,HA2,HA2/A,HEA,HEA2,HEA2/A,HEA8,HEA8/A,HH,HX,HX/A,HXQ4,HXQ4/A,HX26,HX26/A,HX8,HX8/A,LH,LH/A,LHB1,LHB3,LHB5,LHE,LHE/A,LHQ4,LWD1,LWD1/A,LX,LX/A,LXE,LXE/A,LXE8,LXE8/A,LXQ4,LXQ4/A,LXU,LXU/A,LXZ,LX16,PA,PAE2,PAE2/A,PA2,PA2/A,PX,PX/A,PXE8,PXE8/A,PXU,PXU/A,PX26,PX26/A,QA,QAB1,QAB3,QAB3/A,QAE,QAE2,QAE2/A,QAE6,QAE6/A,QAG,QAG/A,QAG2,QAG2/A,QAQ,QAQ4,QAQ4/A,QAR2,QAR2/A,QAW,QAW/A,QA2,QA2/A,QE,QE/A,QH,QH/A,QHB5,QHE,QHE4,QHE4/A,QHP1,QHP1/A,QHQ4,QHQ4/A,QHR,QHR/A,QHR4,QHR4/A,QHZ,QHZ/A,QH26,QH26/A,QKE3,QKE3/A,QKE4,QL2,QME2,QME2/A,QMH,QMH/A,QSE,QSE/A,QSE2,QSE8,QSE8/A,QX,QX/A,QXB6,QXB6/A,QXE,QXE/A,QXE4,QXE4/A,QXE6,QXE6/A,QXE8,QXE8/A,QXQ4,QXQ4/A,QXU,QXU/A,QX26,QX26/A,RA,RA2,RA2/A,RH,RHE,RHE4,RHE4/A,RHQ4,RHQ4/A,RH26,RH26/A,RSC2,RSC2/A,RSS,RSS/A,RX,RX/A,RXQ4,RXQ4/A,RXU,RXU/A,SE,SE/A,SH,SH/A,SHE,SHEZ,SHQ4,SHQ4/A,SMC4,SMC4/A,SME1,SME1/A,SME6,SME6/A,SMX2,SWA4,SWC4,SWC4/A,SX,SX/A,SXE,SXE/A,SXE4,SXE4/A,SXE8,SXE8/A,SXQ4,SXQ4/A,SXU,SXU/A,SX2,VA,VAG2,VAG2/A,VAW,VAW1,VA2,VA2/A,VDE,VDE2,VDE2/A,VH,VKB2,VKB2/A,VME2,VME2/A,VM2,VM2/A,VNT2,VNT2/A,VWA,VWA2,VWA2/A,VWN2,VWN2/A,VW12,VW12/A,VW22,VX,VX/A,VXE,VXE4,VXE4/A,VXE6,VXE6/A,VXQ4,VXQ4/A,VXT1,VXT1/A,VXU,VXU/A,VXU1,VXU1/A,VX26,WMA4,WMT8,WMT8/A,WXE8,WXE8/A
			1	-	-	1274337	----- SMD
			(1)	-	-	-----	QD,QD/A,RD,RD/A,SD,SD/A
			-	(1)	1		
10	90201-415-000	NUT, CAP, 6MM	2	(2)	-	-----	1053526 HH,HX,LH,LHE,LX,LXZ,L1,PX,QA,QAE,QE,QH,QHE,QX,QXE,Q1,Q2,RH,RHE,RX,R1,SE,SH,SHE,SHEZ,SX,SXE,S1,VH,VX,VXE,V1,W1
			2	-	-	-----	HA,HAQ,HEA,PA,QAQ,RA,VA,VAW,VWA
			(2)	-	-	-----	1053526 QD,RD,SD
11	90203-PB2-000	NUT, AIR CLEANER COVER (DACRO COATING)	1	(1)	-	-----	1034589 HA,HH,HX,LH,LHE,LX,LXZ,L1,PA,PX,QA,QAE,QE,QH,QHE,QX,QXE,Q1,RA,RH,RHE,RX,R1,SE,SH,SHE,SHEZ,SX,SXE,S1,VA,VAW,VH,VX,VXE,V1,W1
			(1)	-	-	-----	1034589 QD,RD,SD
	90203-ZA0-800	NUT, WING, 6MM(BLACK)	1	(1)	-	-----	1094660 HEA,Q2,VWA,VXU
			1	(1)	-	1034590	1094660 HA,HH,HX,LH,LHE,LX,LXZ,L1,PA,PX,QA,QAE,QD,QE,QH,QHE,QX,QXE,Q1,RA,RD,RH,RHE,RX,R1,SD,SE,SH,SHE,SHEZ,SX,SXE,S1,VA,VAW,VH,VX,VXE,V1,W1
			1	-	-	-----	1096095 HAQ,HA2,PA2,QAE2,QAQ,QA2,RA2,VA2



E-15-2

AIR CLEANER(3)

L 7

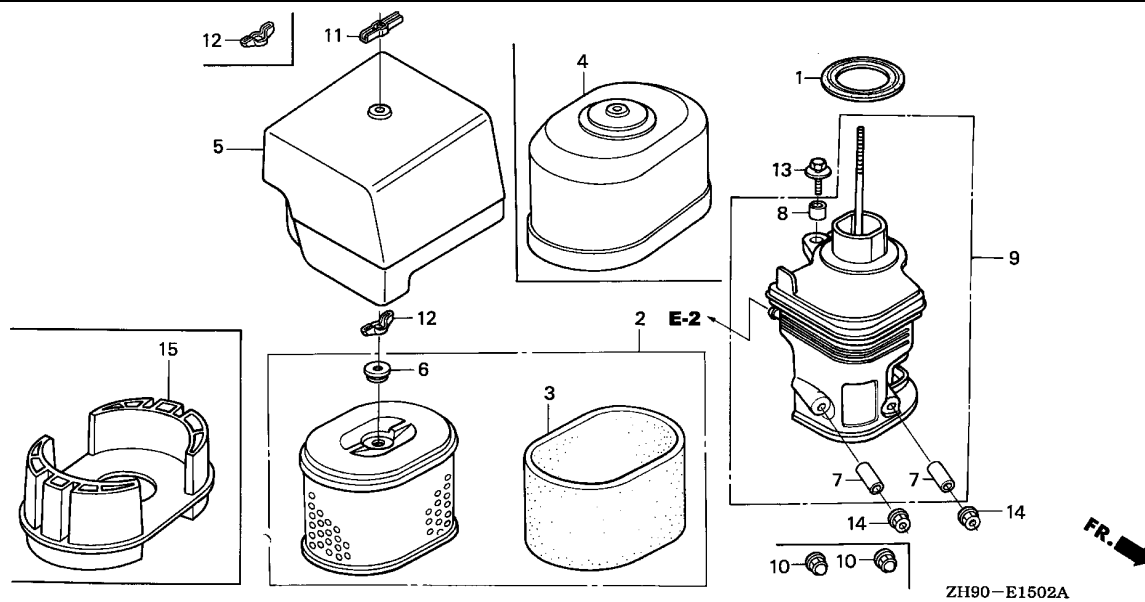

Ref. No.	Part No.	Description	Reqd. QTY			Serial No.	Parts catalogue code
			(1)	(2)	(3)		
12	90325-044-000	NUT, TOOL BOX SETTING	1	(1)	-	1094660 HH,HX,LH,LHE,LX,LXZ,L1,PX,QA,QAE,QE,QH,QHE,QX,QXE,Q1,Q2,RH,RHE,RX R1,SE,SH,SHE,SHEZ,SX,SXE,S1,VH,VX,VXE,VXU,V1,W1	

2

Ref. No.	Part No.	Description	Reqd. QTY			Serial No.	Parts catalogue code
			(1)	(2)	(3)		
12)	90325-044-000	NUT, TOOL BOX SETTING	1	-	-	1096095	HAQ,HA2,PA2,QAE2,QAQ,QA2,RA2,VA2
			(1)	-	-	1094660	QD,RD,SD
			1	-	-		QKE3,QKE3/A,QKE4
			2	(2)	-		ES1,ES1/A,HA2/A,HEA2,HEA2/A,HEA8,HEA8/A,HX/A,HXQ4,HXQ4/A,HX26 HX26/A,HX8,HX8/A,LH/A,LHB1,LHB3,LHB5,LHE/A,LHQ4,LWD1,LWD1/A,LX/A LXE,LXE/A,LXE8,LXE8/A,LXQ4,LXQ4/A,LXU,LXU/A,L16,L1/A,PAE2,PAE2/A PA2/A,PX/A,PXE8,PXE8/A,PXU,PXU/A,PX26,PX26/A,QAB1,QAB3,QAB3/A QAE2/A,QAE6,QAE6/A,QAG,QAG/A,QAG2,QAG2/A,QAQ4,QAQ4/A,QAR2,QAR2/A QAW,QAW/A,QA2/A,QE/A,QH/A,QHB5,QHE4,QHE4/A,QHP1,QHP1/A,QHQ4 QHQ4/A,QHR,QHR/A,QHR4,QHR4/A,QHZ,QHZ/A,QH26,QH26/A,QL2,QME2 QME2/A,QMH,QMH/A,QSE,QSE/A,QSE2,QSE8,QSE8/A,QX/A,QXB6,QXB6/A QXE/A,QXE4,QXE4/A,QXE6,QXE6/A,QXE8,QXE8/A,QXQ4,QXQ4/A,QXU,QXU/A QX26,QX26/A,Q1/A,RA2/A,RHE4,RHE4/A,RHQ4,RHQ4/A,RH26,RH26/A,RSC2 RSC2/A,RSS,RSS/A,RX/A,RXQ4,RXQ4/A,RXU,RXU/A,R1/A,SE/A,SH/A,SHQ4 SHQ4/A,SMC4,SMC4/A,SME1,SME1/A,SME6,SME6/A,SMX2,SWA4,SWC4,SWC4/A SX/A,SXE/A,SXE4,SXE4/A,SXE8,SXE8/A,SXQ4,SXQ4/A,SXU,SXU/A,SX2,S1/A VAG2,VAG2/A,VAW1,VA2/A,VDE,VDE2,VDE2/A,VKB2,VKB2/A,VME2,VME2/A VM2,VM2/A,VNT2,VNT2/A,VWA2,VWA2/A,VWN2,VWN2/A,VW12,VW12/A,VW22 VX/A,VXE4,VXE4/A,VXE6,VXE6/A,VXQ4,VXQ4/A,VXT1,VXT1/A,VXU/A,VXU1 VXU1/A,VX26,WMA4,WMT8,WMT8/A,WXE8,WXE8/A,W1/A
			2	(2)	-	1094661	HA,HEA,HH,HX,LH,LHE,LX,LXZ,L1,PA,PX,QA,QAE,QE,QH,QHE,QX,QXE,Q1,Q2 RA,RH,RHE,RX,R1,SE,SH,SHE,SHEZ,SX,SXE,S1,VA,VAW,VH,VWA,VX,VXE,VXU V1,W1
			2	-	-	1096096	HAQ,HA2,PA2,QAE2,QAQ,QA2,RA2,VA2
			2	-	-	1274337	SMD
			(2)	-	-		QD/A,RD/A,SD/A
			(2)	-	-	1094661	QD,RD,SD
			-	-	2		
13	93494-06020-08	BOLT-WASHER, 6X20	1	(1)	-		HA,HH,HX,HX8,LH,LHE,LX,LXU,LXZ,PA,QA,QAE,QE,QH,QHE,QX,QXE,QXE8 QXU,RA,RH,RHE,RX,RXU,SE,SH,SHE,SHEZ,SX,SXE,SXE8,SXU,VA,VAW,VH,VX VXE,V1
	93404-06020-08	1	1	-		HAQ,HEA,LHB1,LHB3,LHQ4,LX16,QAB1,QAQ,Q2,SX2,VAW1,VDE,VWA,VW22 VX26
			1	-	-	1274337	SMD
	90009-ZE2-003	BOLT-WASHER, 6X22	1	1	-		ES1,ES1/A,HA2,HA2/A,HEA2,HEA2/A,HEA8,HEA8/A,HX/A,HXQ4,HXQ4/A,HX26 HX26/A,HX8/A,LH/A,LHB5,LHE/A,LWD1,LWD1/A,LX/A,LXE,LXE/A,LXE8 LXE8/A,LXQ4,LXQ4/A,LXU/A,L1,L1/A,PAE2,PAE2/A,PA2,PA2/A,PX,PX/A PXE8,PXE8/A,PXU,PXU/A,PX26,PX26/A,QAB3,QAB3/A,QAE2,QAE2/A,QAE6 QAE6/A,QAG,QAG/A,QAG2,QAG2/A,QAQ4,QAQ4/A,QAR2,QAR2/A,QAW,QAW/A QA2,QA2/A,QE/A,QH/A,QHB5,QHE4,QHE4/A,QHP1,QHP1/A,QHQ4,QHQ4/A,QHR QHR/A,QHR4,QHR4/A,QHZ,QHZ/A,QH26,QH26/A,QKE3,QKE3/A,QKE4,QL2,QME2 QME2/A,QMH,QMH/A,QSE,QSE/A,QSE2,QSE8,QSE8/A,QX/A,QXB6,QXB6/A QXE/A,QXE4,QXE4/A,QXE6,QXE6/A,QXE8/A,QXQ4,QXQ4/A,QXU/A,QX26 QX26/A,Q1,Q1/A,RA2,RA2/A,RHE4,RHE4/A,RHQ4,RHQ4/A,RH26,RH26/A,RSC2 RSC2/A,RSS,RSS/A,RX/A,RXQ4,RXQ4/A,RXU/A,R1,R1/A,SE/A,SH/A,SHQ4 SHQ4/A,SMC4,SMC4/A,SME1,SME1/A,SME6,SME6/A,SMX2,SWA4,SWC4,SWC4/A SX/A,SXE/A,SXE4,SXE4/A,SXE8/A,SXQ4,SXQ4/A,SXU/A,S1,S1/A,VAG2 VAG2/A,VA2,VA2/A,VDE2,VDE2/A,VKB2,VKB2/A,VME2,VME2/A,VM2,VM2/A VNT2,VNT2/A,VWA2,VWA2/A,VWN2,VWN2/A,VW12,VW12/A,VX/A,VXE4,VXE4/A VXE6,VXE6/A,VXQ4,VXQ4/A,VXT1,VXT1/A,VXU,VXU/A,VXU1,VXU1/A,WMA4 WMT8,WMT8/A,WXE8,WXE8/A,W1,W1/A
			-	-	1		



E-15-2

AIR CLEANER(3)

L 9

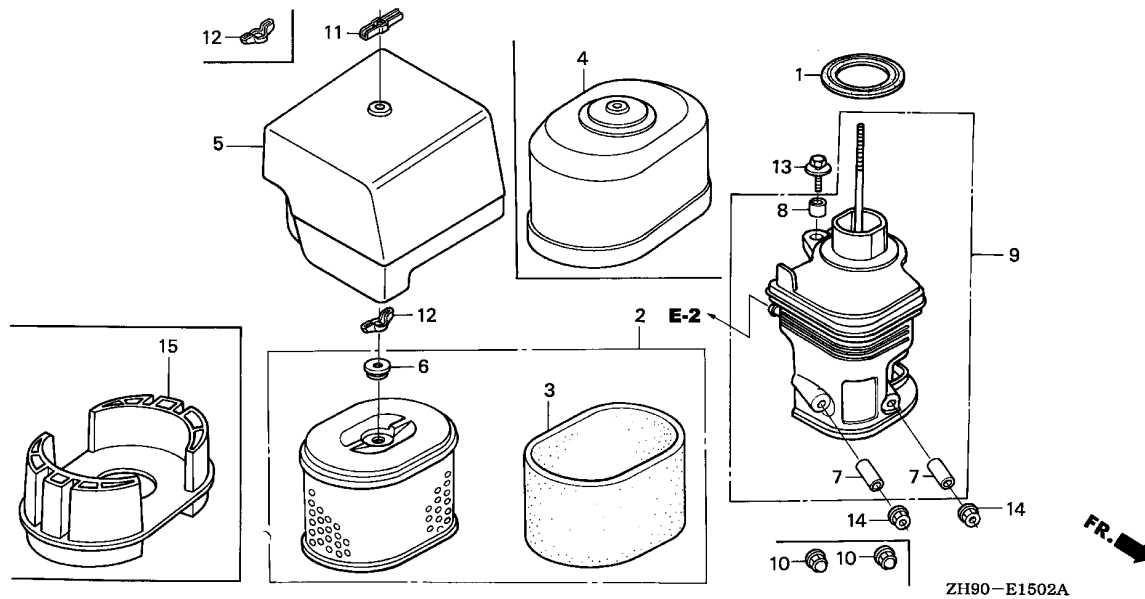

Ref. No.	Part No.	Description	Reqd. QTY			Serial No.	Parts catalogue code				
			(1)	(2)	(3)						
14	94050-06000	NUT, FLANGE, 6MM	2	(2)	-	ES1,ES1/A,HA2,HA2/A,HEA2,HEA2/A,HEA8,HEA8/A,HX/A,HXQ4,HXQ4/A,HX26,HX26/A,HX8,HX8/A,LH/A,LHB1,LHB3,LHB5,LHE/A,LHQ4,LWD1,LWD1/A,LX/A,LXE,LXE/A,LXE8,LXE8/A,LXQ4,LXQ4/A,LXU,LXU/A,LX16,L1/A,PAE2,PAE2/A,PA2,PA2/A,PX/A,PXE8,PXE8/A,PXU,PXU/A,PX26,PX26/A,QAB1,QAB3,QAB3/A,QAE2,QAE2/A,QAE6,QAE6/A,QAG,QAG/A,QAG2,QAG2/A,QAQ4,QAQ4/A,QAR2,QAR2/A,QAW,QAW/A,QA2,QA2/A,QE/A,QH/A,QHB5,QHE4,QHE4/A,QHP1,QHP1/A,QHQ4,QHQ4/A,QHR,QHR/A,QHR4,QHR4/A,QHZ,QHZ/A,QH26,QH26/A,QKE3,QKE3/A,QKE4,QKE4,A,QME2,QME2/A,QMH,QMH/A,QSE,QSE/A,QSE2,QSE8,QSE8/A,QX/A,QXB6,QXB6/A,QXE4,QXE4/A,QXE6,QXE6/A,QXE8,QXE8/A,QXQ4,QXQ4/A,QXU,QXU/A,QX26,QX26/A,Q1/A,RA2,RA2/A,RHE4,RHE4/A,RHQ4,RHQ4/A,RH26,RH26/A,RSC2,RSC2/A,RSS,RSS/A,RX/A,RXQ4,RXQ4/A,RXU,RXU/A,R1/A,SE/A,SH/A,SHQ4,SHQ4/A,SMC4,SMC4/A,SME1,SME1/A,SME6,SME6/A,SMX2,SWA4,SWC4,SWC4/A,SX/A,SXE/A,SXE4,SXE4/A,SXE8,SXE8/A,SXQ4,SXQ4/A,SXU,SXU/A,SX2,S1/A,VAG2,VAG2/A,VAW1,VA2,VA2/A,VDE,VDE2/VDE2/A,VKB2,VKB2/A,VME2,VME2/A,VM2,VM2/A,VNT2,VNT2/A,VWA2,VWA2/A,VWN2,VWN2/A,VW12,VW12/A,VW22,VX/A,VXE4,VXE4/A,VXE6,VXE6/A,VXQ4,VXQ4/A,VXT1,VXT1/A,VXU,VXU/A,VXU1,VXU1/A,VX26,WMA4,WMT8,WMT8/A,WXE8,WXE8/A,W1/A	2	(2)	-	1053527	HH,HX,LH,LHE,LX,LXZ,L1,PX,QA,QAE,QE,QH,QHE,QX,QXE,Q1,Q2,RH,RHE,RX,R1,SE,SH,SHE,SHZ,SX,SXE,S1,VH,VX,VXE,V1,W1
			2	-	-	1274337	SMD				
			(2)	-	-		QD/A,RD/A,SD/A				
			(2)	-	-	1053527	QD,RD,SD				
			-	-	2						

E-15-2

AIR CLEANER(3)

L10

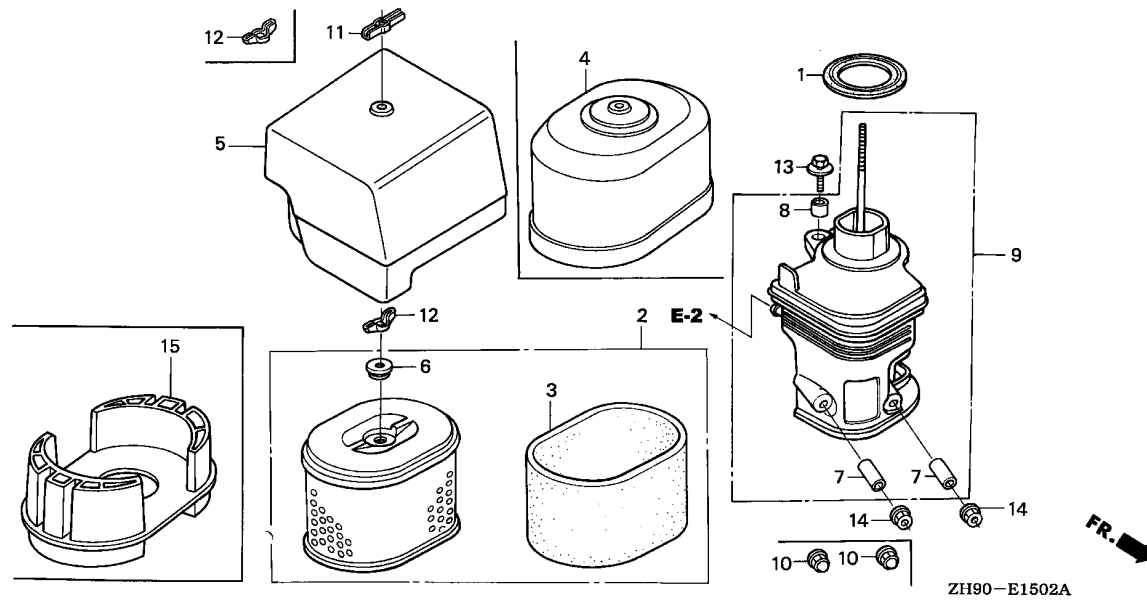

Ref. No.	Part No.	Description	Reqd. QTY			Serial No.	Parts catalogue code
			GX270				
			(1)	(2)	(3)		
15	17235-ZE2-820	NOSE, SILENCER	1	(1)	1	-----	HX,HX/A,HX26,HX26/A,HX8,HX8/A,LX,LX/A,LXE,LXE/A,LXE8,LXE8/A,LXU LXU/A,LXZ,LX16,L1,L1/A,PX,PX/A,PXE8,PXE8/A,PXU,PXU/A,PX26,PX26/A QE,QE/A,QKE3,QKE3/A,QSE,QSE/A,QSE2,QSE8,QSE8/A,QX,QX/A,QXB6 QXB6/A,QXE,QXE/A,QXE8,QXE8/A,QXQ4,QXQ4/A,QXU,QXU/A,Q1,Q1/A,RSC2 RSC2/A,RSS,RSS/A,RX,RX/A,RXP,RXP/A,RXU,RXU/A,R1,R1/A,SE,SE/A,SMX2 SWA4,SX,SX/A,SXE,SXE/A,SXE8,SXE8/A,SXU,SXU/A,SX2,S1,S1/A,VKB2 VKB2/A,VNT2,VNT2/A,VX,VX/A,VXE,VXE6,VXE6/A,VXP,VXP/A,VXQP,VXT1 VXT1/A,VXU,VXU/A,VXU1,VXU1/A,VX26,V1,W1,W1/A
			1	-	-	-----	1340169 SWC4

2

E-15-3

AIR CLEANER(4)

L11

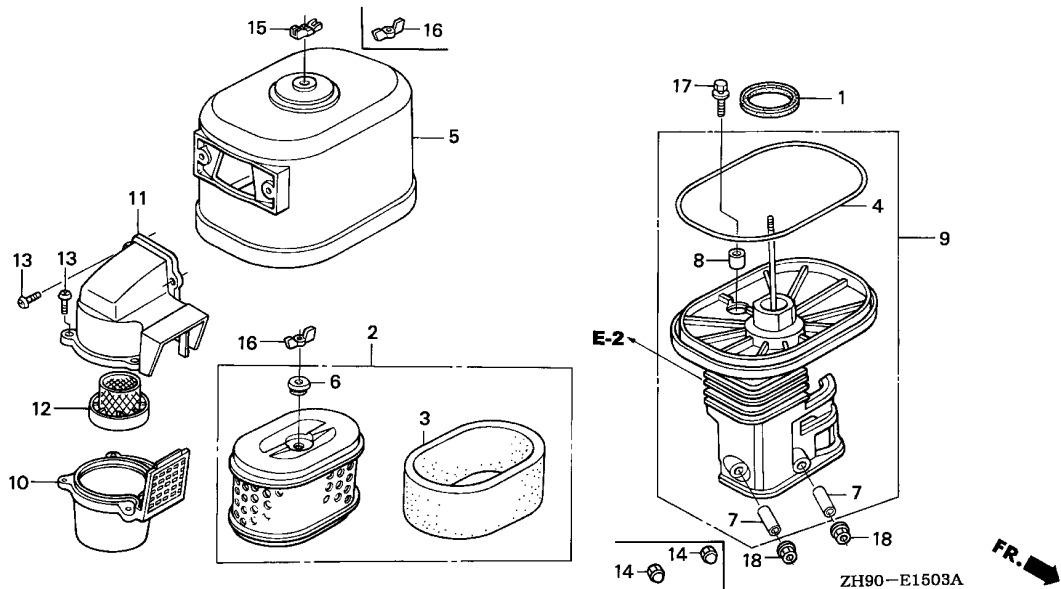

Ref. No.	L.O.N.	(Relative ref. Number) Description	F.R.T.
1	3121E1	PACKING, ELBOW	0.1
2	3121B8	ELEMENT, AIR CLEANER	0.1
3	3121C1	FILTER, OUTER	0.1
4	3121E0	PACKING, AIR CLEANER COVER ...	0.1
9	3121B4	ELBOW, AIR CLEANER	0.1
10	3121A6	CASE, PRE AIR CLEANER	0.1
11	3121A4	CAP, PRE AIR CLEANER	0.1
12	3121C8	GUIDE, PRE AIR CLEANER	0.1

Ref. No.	Part No.	Description	Reqd. QTY			Serial No.	Parts catalogue code
			(1)	(2)	(3)		
1	16271-ZE2-000	PACKING, ELBOW	1	(1)	-	L1,QHC,QSC,QSC9,QWA2,QWA4,QWH2,QXC,QXC4,QXC6,QXC9,Q1,Q2,R1,S1,V1,W1	
	16271-ZE2-010	1	(1)	-	L1/A,QSC9/A,QWA4/A,QWH2/A,QXC4/A,QXC6/A,QXC9/A,Q1/A,R1/A,S1/A,VMA4,VME4,W1/A	
2	17210-ZE3-010	ELEMENT, AIR CLEANER	1	-	-	QHC,QSC,QSC9,QSC9/A,QWA2,QWA4,QWA4/A,QWH2,QWH2/A,QXC,QXC4,QXC4/A,QXC6,QXC6/A,QXC9,QXC9/A,VMA4,VME4	
3	17218-ZE3-000	FILTER, OUTER	-	(1)	-	QHC,QSC,QSC9,QSC9/A,QWA2,QWA4,QWA4/A,QWH2,QWH2/A,QXC,QXC4,QXC4/A,QXC6,QXC6/A,QXC9,QXC9/A,VMA4,VME4	
4	17219-ZE3-840	PACKING, AIR CLEANER COVER ..	1	-	-	QHC,QSC,QSC9,QSC9/A,QWA2,QWA4,QWA4/A,QWH2,QWH2/A,QXC,QXC4,QXC4/A,QXC6,QXC6/A,QXC9,QXC9/A,VMA4,VME4	
5	17230-ZE3-841	COVER COMP., AIR CLEANER (CYCLONE)	1	-	-	QHC,QSC,QSC9,QSC9/A,QWA2,QWA4,QWA4/A,QWH2,QWH2/A,QXC,QXC4,QXC4/A,QXC6,QXC6/A,QXC9,QXC9/A,VMA4,VME4	
6	17232-891-000	GROMMET, AIR CLEANER	1	-	-	QHC,QSC,QSC9,QSC9/A,QWA2,QWA4,QWA4/A,QWH2,QWH2/A,QXC,QXC4,QXC4/A,QXC6,QXC6/A,QXC9,QXC9/A,VMA4,VME4	
7	17238-ZE2-310	COLLAR, AIR CLEANER	-	(1)	-	QHC,QSC,QSC9,QSC9/A,QWA2,QWA4,QWA4/A,QWH2,QWH2/A,QXC,QXC4,QXC4/A,QXC6,QXC6/A,QXC9,QXC9/A,VMA4,VME4	
8	17239-ZE3-840	COLLAR B, AIR CLEANER	1	-	-	QHC,QSC,QSC9,QSC9/A,QWA2,QWA4,QWA4/A,QWH2,QWH2/A,QXC,QXC4,QXC4/A,QXC6,QXC6/A,QXC9,QXC9/A,VMA4,VME4	
			-	(1)	-		

Ref. No.	Part No.	Description	Reqd. QTY			Serial No.	Parts catalogue code
			(1)	(2)	(3)		
9	17410-ZE3-840	ELBOW COMP., AIR CLEANER	1	-	-		QHC,QSC,QSC9,QSC9/A,QWA2,QWA4,QWA4/A,QWH2,QWH2/A,QXC,QXC4,QXC4/A,QXC6,QXC6/A,QXC9,QXC9/A,VMA4,VME4
10	17470-ZE3-841	CASE COMP., PRE AIR CLEANER	1	(1)	-		L1,QHC,QSC,QSC9,QWA2,QWA4,QWH2,QXC,QXC4,QXC6,QXC9,Q1,Q2,R1,S1,V1,W1
	17470-ZE3-842	1	(1)	-		L1/A,QSC9/A,QWA4/A,QWH2/A,QXC4/A,QXC6/A,QXC9/A,Q1/A,R1/A,S1/A,VMA4,VME4,W1/A
11	17475-ZE3-841	CAP, PRE AIR CLEANER	1	-	-		QHC,QSC,QSC9,QSC9/A,QWA2,QWA4,QWA4/A,QWH2,QWH2/A,QXC,QXC4,QXC4/A,QXC6,QXC6/A,QXC9,QXC9/A,VMA4,VME4
12	17476-ZE3-841	GUIDE, PRE AIR CLEANER	1	-	-		QHC,QSC,QSC9,QSC9/A,QWA2,QWA4,QWA4/A,QWH2,QWH2/A,QXC,QXC4,QXC4/A,QXC6,QXC6/A,QXC9,QXC9/A,VMA4,VME4
13	90142-MB0-000	SCREW, PAN, 5X16.5	5	-	-		QHC,QSC,QSC9,QSC9/A,QWA2,QWA4,QWA4/A,QWH2,QWH2/A,QXC,QXC4,QXC4/A,QXC6,QXC6/A,QXC9,QXC9/A,VMA4,VME4
14	90201-415-000	NUT, CAP, 6MM	2	(2)	-	1053526	L1,QHC,Q1,Q2,R1,S1,V1,W1
			2	-	-	1053286	QXC
15	90203-PB2-000	NUT, AIR CLEANER COVER (DACRO COATING)	1	(1)	-	1034589	L1,QXC,Q1,R1,S1,V1,W1
			1	-	-	1094660	QHC
	90203-ZA0-800	NUT, WING, 6MM(BLACK)	1	(1)	-	1094660	QSC,Q2
			1	(1)	-	1034590	1094660 L1,QXC,Q1,R1,S1,V1,W1
16	90325-044-000	NUT, TOOL BOX SETTING	1	(1)	-	1094660	L1,QHC,QSC,QXC,Q1,Q2,R1,S1,V1,W1
			2	-	-		QSC9/A,QWA4/A,QWH2/A,QXC4,QXC4/A,QXC6,QXC6/A,QXC9/A
			2	(2)	-		L1/A,QSC9,QSC9/A,QWA2,QWA4,QWA4/A,QWH2,QWH2/A,QXC4/A,QXC6/A,QXC9,QXC9/A,Q1/A,R1/A,S1/A,VMA4,VME4,W1/A
			2	(2)	-	1094661	L1,QHC,QSC,QXC,Q1,Q2,R1,S1,V1,W1
17	93494-06020-08	BOLT-WASHER, 6X20	1	(1)	-		QHC,QXC,V1
	93404-06020-08	1	1	-		QSC,Q2
	90009-ZE2-003	BOLT-WASHER, 6X22	1	1	-		L1,L1/A,QSC9,QSC9/A,QWA2,QWA4,QWA4/A,QWH2,QWH2/A,QXC4,QXC4/A,QXC6,QXC6/A,QXC9,QXC9/A,Q1,Q1/A,R1,R1/A,S1,S1/A,VMA4,VME4,W1,W1/A
18	94050-06000	NUT, FLANGE, 6MM	2	(2)	-		L1/A,QSC,QSC9,QSC9/A,QWA2,QWA4,QWA4/A,QWH2,QWH2/A,QXC4,QXC4/A,QXC6,QXC6/A,QXC9,QXC9/A,Q1/A,R1/A,S1/A,VMA4,VME4,W1/A
			2	(2)	-	1053527	L1,QHC,Q1,Q2,R1,S1,V1,W1
			2	-	-	1053287	QXC



E-15-4

AIR CLEANER(5)

L13

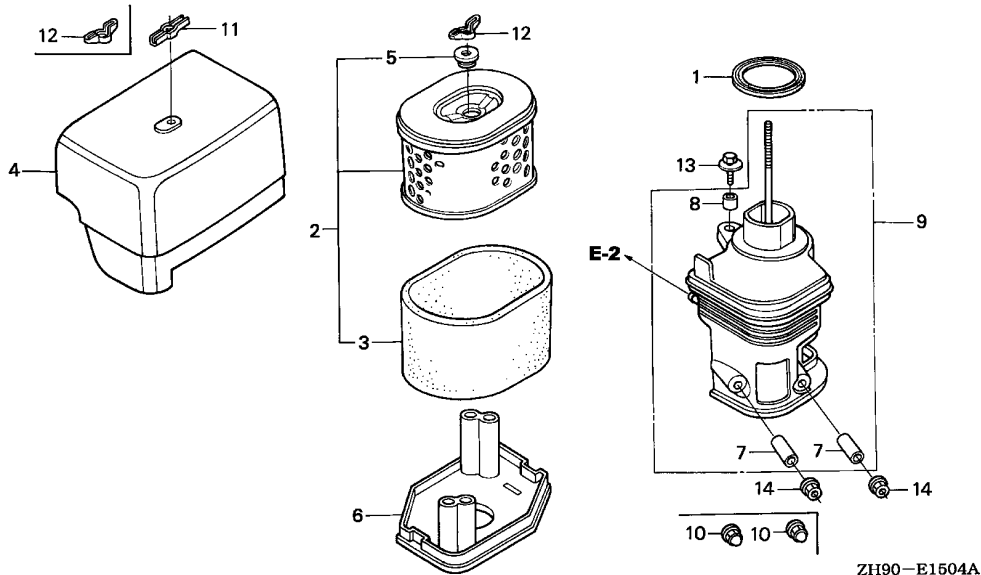

Ref. No.	L.O.N.	(Relative ref. Number) Description	F.R.T.
2	3121B8	ELEMENT, AIR CLEANER	0.1
3	3121C1	FILTER, OUTER	0.1
6	3121D6	NOSE, SILENCER	0.1
9	3121B4	ELBOW, AIR CLEANER	0.1

2

Ref. No.	Part No.	Description	Reqd. QTY			Serial No.	Parts catalogue code
			(1)	(2)	(3)		
1	16271-ZE2-000	PACKING, ELBOW	1	-	-	LTJ,QXB,QXB7,QXEB,SXB,SXB7,SXEB,VD16,VEB6,VNG1,VN17,VSD,VSD7,VWT4	
	16271-ZE2-010	1	-	-	VXB,VXB2,VXB6,VXB7,VXEB,VXE7,VXG,VXTB	
2	17210-ZE3-010	ELEMENT, AIR CLEANER	1	-	-	QXB/A,QXB7/A,SXB/A,SXB7/A,SXEB/A,VNG1/A,VN17/A,VSD/A,VSD7/A,VSH7	
						VWT4/A,VXB/A,VXB7/A,VXEB/A,VXE7/A	
3	17218-ZE3-000	FILTER, OUTER	1	-	-	LTJ,QXB,QXB/A,QXB7,QXB7/A,QXEB,SXB,SXB/A,SXB7,SXB7/A,SXEB,SXEB/A	
						VD16,VEB6,VNG1,VNG1/A,VN17,VN17/A,VSD,VSD/A,VSD7,VSD7/A,VSH7,VWT4	
4	17231-ZH9-N01	COVER, AIR CLEANER (100DB) ..	1	-	-	VWT4/A,VXB,VXB/A,VXB2,VXB6,VXB7,VXB7/A,VXEB,VXEB/A,VXE7,VXE7/A	
						VXG,VXTB	
5	17232-891-000	GROMMET, AIR CLEANER	1	-	-	QXB,QXB/A,QXB7,QXB7/A,SXB,SXB/A,SXB7,SXB7/A,SXEB,SXEB/A,VNG1	
						VNG1/A,VN17,VN17/A,VSD,VSD/A,VSD7,VSD7/A,VSH7,VWT4,VWT4/A,VXB	
6	17235-ZH9-N00	NOSE, SILENCER	1	-	-	VXB/A,VXB7,VXB7/A,VXEB,VXEB/A,VXE7,VXE7/A	
						LTJ,QXB,QXB/A,QXB7,QXB7/A,QXEB,SXB,SXB/A,SXB7,SXB7/A,SXEB,SXEB/A	
						VD16,VEB6,VNG1,VNG1/A,VN17,VN17/A,VSD,VSD/A,VSD7,VSD7/A,VSH7,VWT4	
	17235-ZH9-N01	1	-	-	VWT4/A,VXB,VXB/A,VXB2,VXB6,VXB7,VXB7/A,VXEB,VXEB/A,VXE7,VXE7/A	
						VXG,VXTB	
						LTJ,QXB,QXB7,QXEB,SXB,SXB7,SXEB,VD16,VEB6,VNG1,VN17,VSD,VSD7,VWT4	
						VXB,VXB2,VXB6,VXB7,VXEB,VXE7,VXG,VXTB	
					2401096	QXB/A,QXB7/A,SXB/A,SXB7/A,SXEB/A,VNG1/A,VN17/A,VSD/A,VSD7/A,VSH7	
						VWT4/A,VXB/A,VXB7/A,VXEB/A,VXE7/A	
					2401097	QXB/A,QXB7/A,SXB/A,SXB7/A,SXEB/A,VNG1/A,VN17/A,VSD/A,VSD7/A,VSH7	
						VWT4/A,VXB/A,VXB7/A,VXEB/A,VXE7/A	

Ref. No.	Part No.	Description	Reqd. QTY			Serial No.	Parts catalogue code
			(1)	(2)	(3)		
7	17238-ZE2-310	COLLAR, AIR CLEANER	2	-	-	-----	LTJ,QXB,QXB/A,QXB7,QXB7/A,QXEB,SXB,SXB/A,SXB7,SXB7/A,SXEB,SXEB/A,VD16,VEB6,VNG1,VNG1/A,VN17,VN17/A,VSD,VSD/A,VSD7,VSD7/A,VSH7,VWT4,VWT4/A,VXB,VXB/A,VXB2,VXB6,VXB7,VXB7/A,VXEB,VXEB/A,VXE7,VXE7/A,VXG,VXTB
8	17239-ZE1-000	COLLAR B, AIR CLEANER	1	-	-	-----	LTJ,QXB,QXB/A,QXB7,QXB7/A,QXEB,SXB,SXB/A,SXB7,SXB7/A,SXEB,SXEB/A,VD16,VEB6,VNG1,VNG1/A,VN17,VN17/A,VSD,VSD/A,VSD7,VSD7/A,VSH7,VWT4,VWT4/A,VXB,VXB/A,VXB2,VXB6,VXB7,VXB7/A,VXEB,VXEB/A,VXE7,VXE7/A,VXG,VXTB
9	17410-ZH9-N00	ELBOW COMP., AIR CLEANER	1	-	-	-----	LTJ,QXB,QXB/A,QXB7,QXB7/A,QXEB,SXB,SXB/A,SXB7,SXB7/A,SXEB,SXEB/A,VD16,VEB6,VNG1,VNG1/A,VN17,VN17/A,VSD,VSD/A,VSD7,VSD7/A,VSH7,VWT4,VWT4/A,VXB,VXB/A,VXB2,VXB6,VXB7,VXB7/A,VXEB,VXEB/A,VXE7,VXE7/A,VXG,VXTB
10	90201-415-000	NUT, CAP, 6MM	2	-	-	-----	1053526 QXB,QXEB,SXB,SXEB,VNG1,VSD,VXB,VXEB
11	90203-PB2-000	NUT, AIR CLEANER COVER (DACRO COATING)	1	-	-	-----	1034589 QXB,QXEB,SXB,SXEB,VNG1,VSD,VXB,VXEB
	90203-ZA0-800	NUT, WING, 6MM(BLACK)	1	-	-	-----	1094660 VXG
			1	-	-	1034590	1094660 QXB,QXEB,SXB,SXEB,VNG1,VSD,VXB,VXEB
12	90325-044-000	NUT, TOOL BOX SETTING	1	-	-	-----	1094660 QXB,QXEB,SXB,SXEB,VNG1,VSD,VXB,VXEB,VXG
			2	-	-	-----	-----
				-	-	1094661	-----
			2	-	-	-----	-----
13	93494-06020-08	BOLT-WASHER, 6X20	1	-	-	-----	-----
	93404-06020-08	1	-	-	-----	-----
	90009-ZE2-003	BOLT-WASHER, 6X22	1	-	-	-----	-----
				-	-	-----	-----
14	94050-06000	NUT, FLANGE, 6MM	2	-	-	-----	-----
				-	-	-----	-----
			2	-	-	1053527	-----



E-15-5

AIR CLEANER(6)

L15

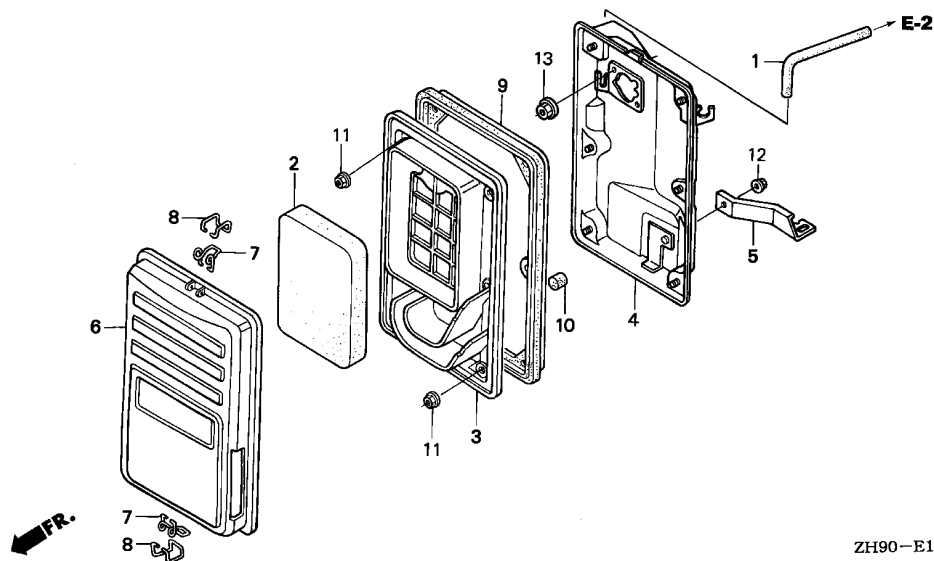

Ref. No.	L.O.N.	(Relative ref. Number) Description	F.R.T.
1	1111K5	TUBE, BREATHER	0.2
2	3121B8	ELEMENT, AIR CLEANER	0.1
3	3121F0	SEPARATOR, AIR CLEANER	0.1
4	3121A5	CASE, AIR CLEANER	0.2
9	3121E8	SEAL, AIR CLEANER CASE	0.1

Ref. No.	Part No.	Description	Reqd. QTY			Serial No.	Parts catalogue code
			(1)	(2)	(3)		
1	15721-ZB4-000	TUBE, BREATHER	1	-	-	-----	ES3,ES3/A,VKE4,VKX4,VMS2,VMT,VMT/A,VMX2,VPE4,VPE4/A,VPE5,VPE7,VPE7/A,VPX4,VPX4/A,VPX5,VPX7,VPX7/A,VSD3,VSD3/A,VS3,VS37,VS37/A
2	17211-899-000	ELEMENT, AIR CLEANER	1	-	-	-----	ES3,ES3/A,VKE4,VKX4,VMS2,VMT,VMT/A,VMX2,VPE4,VPE4/A,VPE5,VPE7,VPE7/A,VPX4,VPX4/A,VPX5,VPX7,VPX7/A,VSD3,VSD3/A,VS3,VS37,VS37/A
3	17212-ZB4-003	SEPARATOR, AIR CLEANER	1	-	-	-----	ES3,ES3/A,VKE4,VKX4,VMS2,VMT,VMT/A,VMX2,VPE4,VPE4/A,VPE5,VPE7,VPE7/A,VPX4,VPX4/A,VPX5,VPX7,VPX7/A,VSD3,VSD3/A,VS3,VS37,VS37/A
4	17220-ZB4-003	CASE COMP., AIR CLEANER	1	-	-	-----	ES3,ES3/A,VKE4,VKX4,VMS2,VMT,VMT/A,VMX2,VPE4,VPE4/A,VPE5,VPE7,VPE7/A,VPX4,VPX4/A,VPX5,VPX7,VPX7/A,VSD3,VSD3/A,VS3,VS37,VS37/A
5	17222-ZB4-000	STAY, AIR CLEANER	1	-	-	-----	ES3,ES3/A,VKE4,VKX4,VMS2,VMT,VMT/A,VMX2,VPE4,VPE4/A,VPE5,VPE7,VPE7/A,VPX4,VPX4/A,VPX5,VPX7,VPX7/A,VSD3,VSD3/A,VS3,VS37,VS37/A
6	17231-899-000	COVER COMP., AIR CLEANER	1	-	-	-----	ES3,ES3/A,VKE4,VKX4,VMS2,VMT,VMT/A,VMX2,VPE4,VPE4/A,VPE5,VPE7,VPE7/A,VPX4,VPX4/A,VPX5,VPX7,VPX7/A,VSD3,VSD3/A,VS3,VS37,VS37/A
7	17235-899-000	CLIP A, AIR CLEANER WIRE	2	-	-	-----	ES3,ES3/A,VKE4,VKX4,VMS2,VMT,VMT/A,VMX2,VPE4,VPE4/A,VPE5,VPE7,VPE7/A,VPX4,VPX4/A,VPX5,VPX7,VPX7/A,VSD3,VSD3/A,VS3,VS37,VS37/A
8	17236-899-000	CLIP B, AIR CLEANER WIRE	2	-	-	-----	ES3,ES3/A,VKE4,VKX4,VMS2,VMT,VMT/A,VMX2,VPE4,VPE4/A,VPE5,VPE7,VPE7/A,VPX4,VPX4/A,VPX5,VPX7,VPX7/A,VSD3,VSD3/A,VS3,VS37,VS37/A
9	17252-899-000	SEAL, AIR CLEANER	1	-	-	-----	ES3,ES3/A,VKE4,VKX4,VMS2,VMT,VMT/A,VMX2,VPE4,VPE4/A,VPE5,VPE7,VPE7/A,VPX4,VPX4/A,VPX5,VPX7,VPX7/A,VSD3,VSD3/A,VS3,VS37,VS37/A
10	17367-413-690	FILTER, DRAIN TUBE	1	-	-	-----	ES3,ES3/A,VKE4,VKX4,VMS2,VMT,VMT/A,VMX2,VPE4,VPE4/A,VPE5,VPE7,VPE7/A,VPX4,VPX4/A,VPX5,VPX7,VPX7/A,VSD3,VSD3/A,VS3,VS37,VS37/A
11	94050-05000	NUT, FLANGE, 5MM	6	-	-	-----	ES3,ES3/A,VKE4,VKX4,VMS2,VMT,VMT/A,VMX2,VPE4,VPE4/A,VPE5,VPE7,VPE7/A,VPX4,VPX4/A,VPX5,VPX7,VPX7/A,VSD3,VSD3/A,VS3,VS37,VS37/A
12	94050-06080	NUT, FLANGE, 6MM	1	-	-	-----	ES3,ES3/A,VKE4,VKX4,VMS2,VMT,VMT/A,VMX2,VPE4,VPE4/A,VPE5,VPE7,VPE7/A,VPX4,VPX4/A,VPX5,VPX7,VPX7/A,VSD3,VSD3/A,VS3,VS37,VS37/A
13	94050-06000	NUT, FLANGE, 6MM	2	-	-	-----	ES3,ES3/A,VKE4,VKX4,VMS2,VMT,VMT/A,VMX2,VPE4,VPE4/A,VPE5,VPE7,VPE7/A,VPX4,VPX4/A,VPX5,VPX7,VPX7/A,VSD3,VSD3/A,VS3,VS37,VS37/A

2

E-15-6

AIR CLEANER(7)

L16

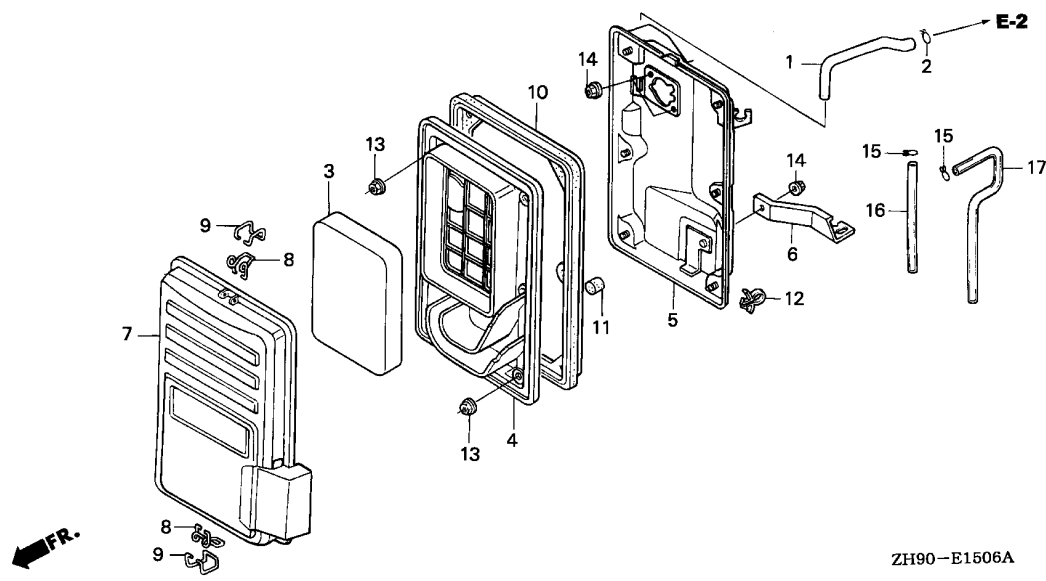

ZH90-E1506A

Ref. No.	L.O.N.	(Relative ref. Number) Description	F.R.T.
1	1111K5	TUBE, BREATHER	0.2
3	3121B8	ELEMENT, AIR CLEANER	0.1
4	3121F0	SEPARATOR, AIR CLEANER	0.1
5	3121A5	CASE, AIR CLEANER	0.2
10	3121E8	SEAL, AIR CLEANER CASE	0.1

Ref. No.	Part No.	Description	Reqd. QTY			Serial No.	Parts catalogue code
			(1)	(2)	(3)		
1	15721-ZB7-000	TUBE, BREATHER	1	-	-	ESS,ESS/A	
2	15772-292-010	CLIP, BREATHER TUBE	1	-	-	ESS,ESS/A	
3	17211-899-000	ELEMENT, AIR CLEANER	1	-	-	ESS,ESS/A	
4	17212-ZB4-003	SEPARATOR, AIR CLEANER	1	-	-	ESS,ESS/A	
5	17220-ZB7-000	CASE COMP., AIR CLEANER	1	-	-	ESS,ESS/A	
6	17222-ZB7-000	STAY, AIR CLEANER	1	-	-	ESS,ESS/A	
7	17231-ZB7-000	COVER COMP., AIR CLEANER	1	-	-	ESS,ESS/A	
8	17235-899-000	CLIP A, AIR CLEANER WIRE	2	-	-	ESS,ESS/A	
9	17236-899-000	CLIP B, AIR CLEANER WIRE	2	-	-	ESS,ESS/A	
10	17252-899-000	SEAL, AIR CLEANER	1	-	-	ESS,ESS/A	
11	17367-413-690	FILTER, DRAIN TUBE	1	-	-	ESS,ESS/A	
12	90624-SB0-003	CLIP, WIRE HARNESS	1	-	-	ESS,ESS/A	
13	94050-05000	NUT, FLANGE, 5MM	6	-	-	ESS,ESS/A	
14	94050-06000	NUT, FLANGE, 6MM	3	-	-	ESS,ESS/A	
15	95002-45000	CLIP, TUBE (C8)	2	-	-	ESS,ESS/A	
16	95003-09023-31	TUBE, VINYL, 4.5X8X230 (95003-09001-60M)	1	-	-	ESS,ESS/A	
17	95003-09038-31	TUBE, VINYL, 4.5X8X380 (95003-09001-60M)	1	-	-	ESS,ESS/A	

2

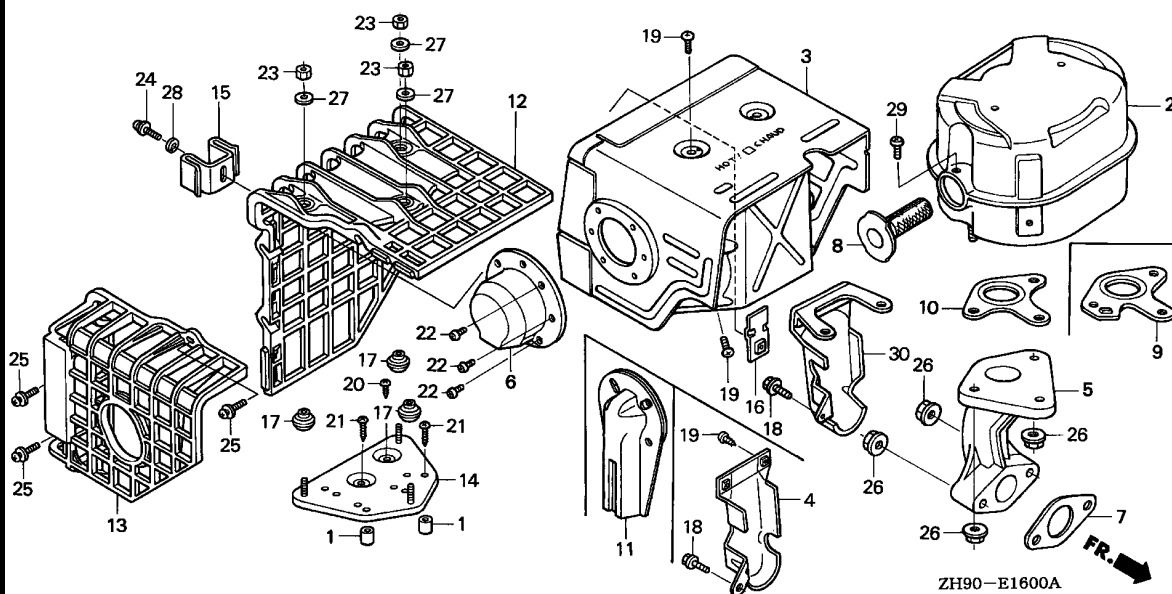

Ref. No.	L.O.N.	(Relative ref. Number) Description	F.R.T.
2	3131C5	MUFFLER, EXHAUST	0.2
3	3131D6	PROTECTOR, EXHAUST MUFFLER ...	0.2
5	3131D6	PROTECTOR, EXHAUST MUFFLER ...	0.2
7	3131B5	GASKET, EXHAUST PIPE	0.2
8	3131A1	ARRESTER, SPARK	0.2
.INCLUDES: Spark arrester check (9)			
10	3131B4	GASKET, EXHAUST MUFFLER	0.2
12	3131A7	COVER, EXHAUST MUFFLER	0.1
13	3131K6	COVER, EXHAUST MUFFLER :RIGHT	0.1
14	3131A2	BASE, EXHAUST MUFFLER COVER ..	0.2

ZH90-E1600A



Ref. No.	Part No.	Description	Reqd. QTY			Serial No.	Parts catalogue code
			(1)	(2)	(3)		
1	17233-896-701	COLLAR, AIR CLEANER CASE	(2)	-	-	-----	LHQ4,QAQ4,QAQ4/A,QHE4,QHE4/A,QHQ4,QHQ4/A,QHR,QHR/A,QHR4,QHR4/A,RHE4,RHE4/A,RHQ4,RHQ4/A,SHQ4,SHQ4/A,SKE1,SWC4,SWC4/A,VMA4,VME4,WMA4
2	18310-ZE2-W00	MUFFLER COMP.	1	-	1	-----	HA,HAP,HAP/A,HAQ,HA2,HA2/A,HEA,HEA2,HEA2/A,HEA8,HEA8/A,HH,LH,LH/A,LHB1,LHB3,LHB5,LHE,LHE/A,LHQ4,LJ,LJ/A,LJC,LJC/A,LJG,LJG/A,LSS,LT,LT/A,LW,LW/A,LWD,PA,PAE2,PAE2/A,PA2,PA2/A,QA,QAB1,QAB3,QAB3/A,QAE,QAE2,QAE2/A,QAE6,QAE6/A,QAG,QAG/A,QAG2,QAG2/A,QAQ,QAQ4,QAQ4/A,QAR2,QAR2/A,QA2,QA2/A,QD,QD/A,QH,QH/A,QHB5,QHC,QHE,QHE4,QHE4/A,QHP1,QHP1/A,QHQ4,QHQ4/A,QHR,QHR/A,QHR4,QHR4/A,QHZ,QHZ/A,QH26,QH26/A,QL2,QMH,QMH/A,QP,QP/A,QT,QT/A,QX26,QX26/A,RA,RA2,RA2/A,RD,RD/A,RH,RHE,RHE4,RHE4/A,RHQ4,RHQ4/A,RH26,RH26/A,RSS,RSS/A,SD,SD/A,SH,SH/A,SHE,SHEZ,SHQ4,SHQ4/A,SJ,SJ/A,SJG,SJG/A,SK,SKE1,SMD,SMX2,SN,SN/A,SW,SWC4,SWC4/A,SWE,VA,VAG2,VAG2/A,VAW,VAW1,VA2,VA2/A,VDE,VDE2,VDE2/A,VH,VMA4,VME2,VME2/A,VME4,VM2,VM2/A,VWA,VWA2,VWA2/A,VWN2,VWN2/A,VW12,VW12/A,VW22,WMA4,WMT8,WMT8/A,WXE8,WXE8/A
			-	(1)	-		

Ref. No.	Part No.	Description	Reqd. QTY			Serial No.	Parts catalogue code
			(1)	(2)	(3)		
3	18320-ZE2-W01	PROTECTOR COMP., MUFFLER (STD.)	1	-	1	-----	HA,HAP,HAP/A,HAQ,HA2,HA2/A,HEA,HEA2,HEA2/A,HEA8,HEA8/A,HH,LH,LH/A,LHB1,LHB3,LHB5,LHE,LHE/A,LHQ4,LJ,LJ/A,LJC,LJC/A,LJG,LJG/A,LSS,LT,LT/A,LW,LW/A,LWD,PA,PAE2,PAE2/A,PA2,PA2/A,QA,QAB1,QAB3,QAB3/A,QAE,QAE2/A,QAE6,QAE6/A,QAG,QAG/A,QAG2,QAG2/A,QAQ,QAQ4,QAQ4/A,QAR2,QAR2/A,QA2,QA2/A,QD,QD/A,QH,QH/A,QHB5,QHC,QHE,QHE4,QHE4/A,QHP1,QHP1/A,QHQ4,QHQ4/A,QHR,QHR/A,QHR4,QHR4/A,QHZ,QHZ/A,QH26,QH26/A,QL2,QMH,QMH/A,QP,QP/A,QT,QT/A,QX26,QX26/A,RA,RA2,RA2/A,RD,RD/A,RH,RHE,RHE4,RHE4/A,RHQ4,RHQ4/A,RH26,RH26/A,RSS,RSS/A,SD,SD/A,SH,SH/A,SHE,SHEZ,SHQ4,SHQ4/A,SJ,SJ/A,SJG,SJG/A,SK,SKE1,SMD,SMX2,SN,SN/A,SW,SWC4,SWC4/A,SWE,VA,VAG2,VAG2/A,VAW,VAW1,VA2,VA2/A,VDE,VDE2,VDE2/A,VH,VMA4,VME2,VME2/A,VME4,VM2,VM2/A,VWA,VWA2,VWA2/A,VWN2,VWN2/A,VW12,VW12/A,VW22,WMA4,WMT8,WMT8/A,WXE8,WXE8/A
4	18323-ZE2-W00	PROTECTOR, EX. PIPE	1	-	1	-----	HA,HAP,HAP/A,HAQ,HA2,HA2/A,HEA,HEA2,HEA2/A,HEA8,HEA8/A,LJ,LJ/A,LJC,LJC/A,LJG,LJG/A,LSS,LT,LT/A,PA,PAE2,PAE2/A,PA2,PA2/A,QA,QAB1,QAB3,QAB3/A,QAE,QAE2,QAE2/A,QAE6,QAE6/A,QAG,QAG/A,QAG2,QAG2/A,QAQ,QAQ4,QAQ4/A,QAR2,QAR2/A,QA2,QA2/A,QL2,QX26,QX26/A,RA,RA2,RA2/A,SJ,SJ/A,SJG,SJG/A,SK,SMX2,VA,VAG2,VAG2/A,VAW,VAW1,VA2,VA2/A,VDE,VDE2,VDE2/A,VMA4,VME2,VME2/A,VME4,VM2,VM2/A,VWA,VWA2,VWA2/A,VWN2,VWN2/A,VW12,VW12/A,VW22
			1	-	-	-----	1283257 SWC4
5	18330-ZE2-W00	PIPE, EX.	1	-	1	-----	HA,HAP,HAP/A,HAQ,HA2,HA2/A,HEA,HEA2,HEA2/A,HEA8,HEA8/A,HH,LH,LH/A,LHB1,LHB3,LHB5,LHE,LHE/A,LHQ4,LJ,LJ/A,LJC,LJC/A,LJG,LJG/A,LSS,LT,LT/A,LW,LW/A,LWD,PA,PAE2,PAE2/A,PA2,PA2/A,QA,QAB1,QAB3,QAB3/A,QAE,QAE2,QAE2/A,QAE6,QAE6/A,QAG,QAG/A,QAG2,QAG2/A,QAQ,QAQ4,QAQ4/A,QAR2,QAR2/A,QA2,QA2/A,QD,QD/A,QH,QH/A,QHB5,QHC,QHE,QHE4,QHE4/A,QHP1,QHP1/A,QHQ4,QHQ4/A,QHR,QHR/A,QHR4,QHR4/A,QHZ,QHZ/A,QH26,QH26/A,QL2,QMH,QMH/A,QP,QP/A,QT,QT/A,QX26,QX26/A,RA,RA2,RA2/A,RD,RD/A,RH,RHE,RHE4,RHE4/A,RHQ4,RHQ4/A,RH26,RH26/A,RSS,RSS/A,SD,SD/A,SH,SH/A,SHE,SHEZ,SHQ4,SHQ4/A,SJ,SJ/A,SJG,SJG/A,SK,SKE1,SMD,SMX2,SN,SN/A,SW,SWE,VA,VAG2,VAG2/A,VAW,VAW1,VA2,VA2/A,VDE,VDE2,VDE2/A,VH,VMA4,VME2,VME2/A,VME4,VM2,VM2/A,VWA,VWA2,VWA2/A,VWN2,VWN2/A,VW12,VW12/A,VW22,WMA4,WMT8,WMT8/A,WXE8,WXE8/A
			1	-	-	-----	1283257 SWC4
	18330-ZH9-N00	1	-	-	-----	SWC4/A
			1	-	-	-----	1283258 SWC4
6	18331-ZE2-810	CAP, MUFFLER	1	-	1	-----	HA,HAP,HAP/A,HAQ,HA2,HA2/A,HEA,HEA2,HEA2/A,HEA8,HEA8/A,LSS,LT,LT/A,LW,LW/A,PA,PAE2,PAE2/A,PA2,PA2/A,QA,QAB1,QAB3,QAB3/A,QAE,QAE2,QAE2/A,QAE6,QAE6/A,QAG,QAG/A,QAQ,QAQ4,QAQ4/A,QAR2,QAR2/A,QA2,QA2/A,QL2,QMH,QMH/A,QP,QP/A,QT,QT/A,QX26,QX26/A,RA,RA2,RA2/A,RSS,RSS/A,SMD,SW,SWE,VA,VAG2,VAG2/A,VAW,VA2,VA2/A,VDE,VDE2,VDE2/A,VMA4,VME4,VWA,VWA2,VWA2/A,VWN2,VWN2/A,VW22
			-	(1)	-		



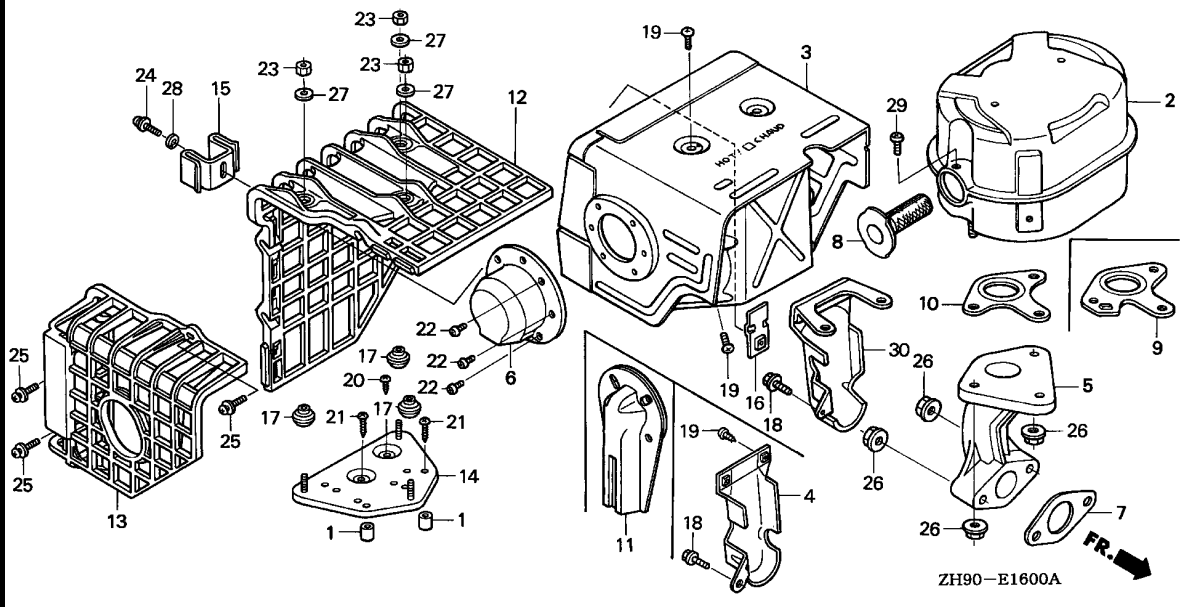

Ref. No.	Part No.	Description	Reqd. QTY			Serial No.	Parts catalogue code	
			(1)	(2)	(3)			
7	18333-ZE3-800	GASKET, EX. PIPE	1	-	1	-----	HA,HAP,HAP/A,HAQ,HA2,HA2/A,HEA,HEA2,HEA2/A,HEA8,HEA8/A,HH,LH,LH/A,LHB1,LHB3,LHB5,LHE,LHE/A,LHQ4,LJ,LJ/A,LJC,LJC/A,LJG,LJG/A,LSS,LT,LT/A,LW,LW/A,LWD,PA,PAE2,PAE2/A,PA2,PA2/A,QA,QAB1,QAB3,QAB3/A,QAE,QAE2,QAE2/A,QAE6,QAE6/A,QAG,QAG/A,QAG2,QAG2/A,QAQ,QAQ4,QAQ4/A,QAR2,QAR2/A,QA2,QA2/A,QD,QD/A,QH,QH/A,QHB5,QHC,QHE,QHE4,QHE4/A,QHP1,QHP1/A,QHQ4,QHQ4/A,QHR,QHR/A,QHR4,QHR4/A,QHZ,QHZ/A,QH26,QH26/A,QL2,QMH,QMH/A,QP,QP/A,QT,QT/A,QX26,QX26/A,RA,RA2,RA2/A,RD,RD/A,RH,RHE,RHE4,RHE4/A,RHQ4,RHQ4/A,RH26,RH26/A,SD,SD/A,SH,SH/A,SHE,SHEZ,SHQ4,SHQ4/A,SJ,SJ/A,SJG,SJG/A,SK,SMD,SMX2,SN,SN/A,SW,SWE,VA,VAG2,VAW,VAW1,VA2,VA2/A,VDE,VDE2,VDE2/A,VH,VMA4,VME2,VME2/A,VME4,VMS2,VMX2,VM2,VM2/A,VWA,VWA2,VWA2/A,VWN2,VWN2/A,VW12,VW12/A,VW22,WMA4,WMT8,WMT8/A,WXE8,WXE8/A	
	18333-ZK6-Y00	-	(1)	-	-----	SKE1	
			1	-	-	-----	1457779 SWC4	
	18333-ZF6-W01	1	-	-	-----	RSS,RSS/A,SWC4/A	
			1	-	-	-----	1457780 SWC4	
8	18355-ZE2-010	ARRESTER, SPARK	1	-	-	-----	QA,QAB1,QAB3,QAB3/A,QAE,QAE2,QAE2/A,QAE6,QAE6/A,QAG,QAG/A,QAQ,QAQ4,QAQ4/A,QAR2,QAR2/A,QA2,QA2/A,QL2,QX26,QX26/A,RSS,RSS/A,SMX2,SWC4/A,VA,VAG2,VAG2/A,VAW,VAW1,VA2,VA2/A,VDE,VDE2,VDE2/A,VMA4,VMA4/VME2,VME2/A,VME4,VM2,VM2/A,VWA,VWA2,VWA2/A,VWN2,VWN2/A,VW12,VW12/A,VW22	
			1	-	-	1340170	-----	SWC4
			(1)	-	(1)	-----	HA,HAP,HAP/A,HAQ,HA2,HA2/A,HEA,HEA2,HEA2/A,HEA8,HEA8/A,PA,PA2,PA2/A,RA,RA2,RA2/A	
			-	(1)	-	-----		

Ref. No.	Part No.	Description	Reqd. QTY			Serial No.	Parts catalogue code
			(1)	(2)	(3)		
9	18381-ZE2-W10	GASKET, MUFFLER (ARRESTER) ..	1	-	-	-----	QA,QAB1,QAB3,QAB3/A,QAE,QAE2,QAE2/A,QAE6,QAE6/A,QAG,QAG/A,QAQ QAQ4,QAQ4/A,QAR2,QAR2/A,QA2,QA2/A,QL2,QX26,QX26/A,RSS,RSS/A,SMX2 SWC4/A,VA,VAG2,VAG2/A,VAW,VAW1,VA2,VA2/A,VDE,VDE2,VDE2/A,VMA4 VME2,VME2/A,VME4,VM2,VM2/A,VWA,VWA2,VWA2/A,VWN2,VWN2/A,VW12 VW12/A,VW22
			1	-	-	1340170	----- SWC4
			(1)	-	(1)	-----	HA,HAP,HAP/A,HAQ,HA2,HA2/A,HEA,HEA2,HEA2/A,HEA8,HEA8/A,PA,PA2 PA2/A,RA,RA2,RA2/A
10	18381-ZE2-800	GASKET, MUFFLER	1	(1)	-	-----	HA,HAP,HAP/A,HAQ,HA2,HA2/A,HEA,HEA2,HEA2/A,HEA8,HEA8/A,HH,LH,LH/A LHB1,LHB3,LHB5,LHE,LHE/A,LHQ4,LJ,LJ/A,LJC,LJC/A,LJG,LJG/A,LSS,LT LT/A,LW,LW/A,LWD,PA,PAE2,PAE2/A,PA2,PA2/A,QAG2,QAG2/A,QD,QD/A,QH QH/A,QHB5,QHC,QHE,QHE4,QHE4/A,QHP1,QHP1/A,QHQ4,QHQ4/A,QHR,QHR/A QHR4,QHR4/A,QHZ,QHZ/A,QH26,QH26/A,QMH,QMH/A,QP,QP/A,QT,QT/A,RA RA2,RA2/A,RD,RD/A,RH,RHE,RHE4,RHE4/A,RHQ4,RHQ4/A,RH26,RH26/A,SD SD/A,SH,SH/A,SHE,SHEZ,SHQ4,SHQ4/A,SJ,SJ/A,SJG,SJG/A,SK,SK1,SMD SN,SN/A,SW,SWE,VH,WMA4,WMT8,WMT8/A,WXE8,WXE8/A
			1	-	-	1340169	----- SWC4
			-	(1)	-	-----	
11	18430-ZK9-W50	DEFLECTOR COMP., MUFFLER	(1)	-	-	-----	QAQ4,QAQ4/A
12	18433-ZK9-W40	COVER COMP., MUFFLER	(1)	-	-	-----	LHQ4,QAQ4,QAQ4/A,QHE4,QHE4/A,QHQ4,QHQ4/A,QHR,QHR/A,QHR4,QHR4/A RHE4,RHE4/A,RHQ4,RHQ4/A,SHQ4,SHQ4/A,WMA4
	18433-ZF6-W40	(1)	-	-	-----	VMA4,VME4
13	18434-ZK9-W40	COVER COMP., MUFFLER RR.	(1)	-	-	-----	LHQ4,QAQ4,QAQ4/A,QHE4,QHE4/A,QHQ4,QHQ4/A,QHR,QHR/A,QHR4,QHR4/A RHE4,RHE4/A,RHQ4,RHQ4/A,SHQ4,SHQ4/A,WMA4
	18434-ZF6-W40	(1)	-	-	-----	VMA4,VME4
14	18436-ZH8-W40	BASE COMP., MUFFLER COVER ...	(1)	-	-	-----	LHQ4,QAQ4,QAQ4/A,QHE4,QHE4/A,QHQ4,QHQ4/A,QHR,QHR/A,QHR4,QHR4/A RHE4,RHE4/A,RHQ4,RHQ4/A,SHQ4,SHQ4/A,SKE1,SWC4,SWC4/A,VMA4,VME4 WMA4
15	18437-ZF6-W40	STAY, MUFFLER COVER	(1)	-	-	-----	LHQ4,QAQ4,QAQ4/A,QHE4,QHE4/A,QHQ4,QHQ4/A,QHR,QHR/A,QHR4,QHR4/A RHE4,RHE4/A,RHQ4,RHQ4/A,SHQ4,SHQ4/A,SKE1,SWC4,SWC4/A,VMA4,VME4 WMA4
16	18438-ZF6-W40	PLATE, SET	(1)	-	-	-----	LHQ4,QAQ4,QAQ4/A,QHE4,QHE4/A,QHQ4,QHQ4/A,QHR,QHR/A,QHR4,QHR4/A RHE4,RHE4/A,RHQ4,RHQ4/A,SHQ4,SHQ4/A,SKE1,SWC4,SWC4/A,VMA4,VME4 WMA4
17	18466-ZH8-W40	SPACER, MUFFLER COVER	(3)	-	-	-----	LHQ4,QAQ4,QAQ4/A,QHE4,QHE4/A,QHQ4,QHQ4/A,QHR,QHR/A,QHR4,QHR4/A RHE4,RHE4/A,RHQ4,RHQ4/A,SHQ4,SHQ4/A,SKE1,SWC4,SWC4/A,VMA4,VME4 WMA4
18	90013-883-000	BOLT, FLANGE, 6X12(CT200) ...	1	-	1	-----	HA,HAP,HAP/A,HAQ,HA2,HA2/A,HEA,HEA2,HEA2/A,HEA8,HEA8/A,LJ,LJ/A LJC,LJC/A,LJG,LJG/A,LSS,LT,LT/A,PA,PAE2,PAE2/A,PA2,PA2/A,QA,QAB1 QAB3,QAB3/A,QAE,QAE2,QAE2/A,QAE6,QAE6/A,QAG,QAG/A,QAG2,QAG2/A,QAQ QAQ4,QAQ4/A,QAR2,QAR2/A,QA2,QA2/A,QL2,QX26,QX26/A,RA,RA2,RA2/A,SJ SJ/A,SJG,SJG/A,SK,SMX2,SWC4,SWC4/A,VA,VAG2,VAG2/A,VAW,VAW1,VA2 VA2/A,VDE,VDE2,VDE2/A,VMA4,VME2,VME2/A,VWA,VWA2 VWA2/A,VWN2,VWN2/A,VW12,VW12/A,VW22
			-	(1)	-	-----	



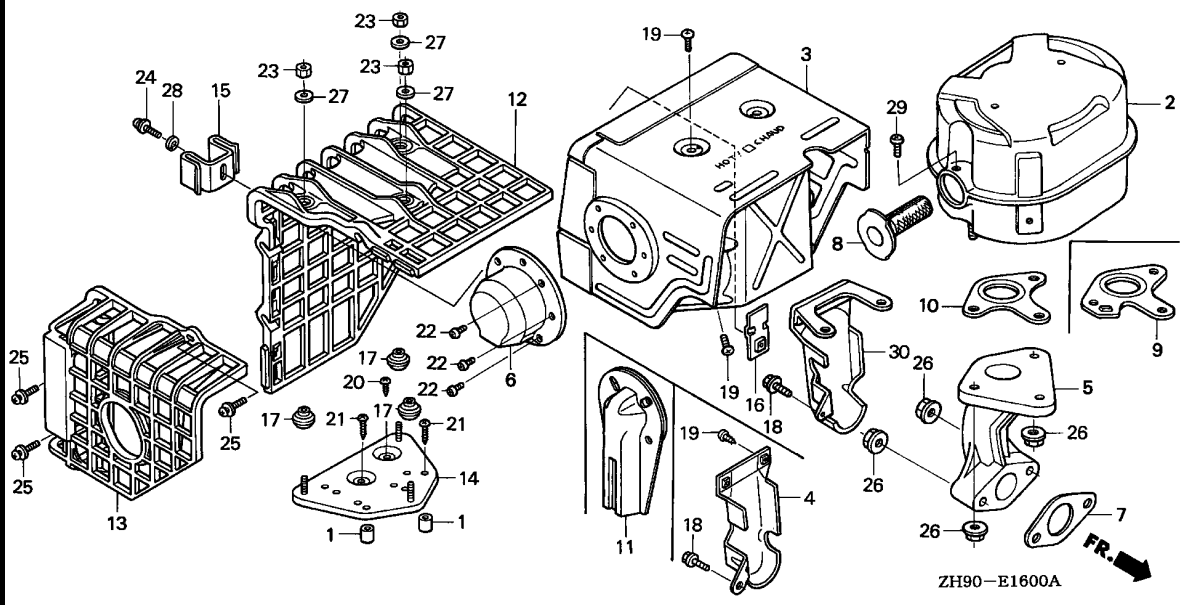

Ref. No.	Part No.	Description	Reqd. QTY			Serial No.	Parts catalogue code
			(1)	(2)	(3)		
19	90050-ZE1-000	SCREW, TAPPING, 5X8	4	(7)	-		HH, LH, LH/A, LHB1, LHB3, LHB5, LHE, LHE/A, LHQ4, LT, LT/A, LW, LW/A, LWD, QD, QD/A, QH, QH/A, QHB5, QHC, QHE, QHE4, QHE4/A, QHP1, QHP1/A, QHQ4, QHQ4/A, QHR, QHR/A, QHR4, QHR4/A, QHZ, QHZ/A, QH26, QH26/A, QMH, QMH/A, QP, QP/A, QT, QT/A, Q2, RD, RD/A, RH, RHE, RHE4, RHE4/A, RHQ4, RHQ4/A, RH26, RH26/A, RSS, RSS/A, SD, SD/A, SH, SH/A, SHE, SHEZ, SHQ4, SHQ4/A, SKE1, SMD, SN, SN/A, SW, SWE, VH, WMA4, WMT8, WMT8/A, WXE8, WXE8/A
			5	-	-		QAQ4, QAQ4/A, SWC4/A
			6	(6)	6		HA, HAP, HAP/A, HAQ, HA2, HA2/A, HEA, HEA2, HEA2/A, HEA8, HEA8/A, LJ, LJ/A, LJC, LJC/A, LJG, LJG/A, LSS, L1, L1/A, PA, PAE2, PAE2/A, PA2, PA2/A, QA, QAE, QAE2, QAE2/A, QAG, QAG/A, QAG2, QAG2/A, QAQ, QAR2, QAR2/A, QA2, QA2/A, QL2, Q1, Q1/A, RA, RA2, RA2/A, R1, R1/A, SJ, SJ/A, SJG, SJG/A, SK, SMX2, S1, S1/A, VAW, VAW1, VA2, VA2/A, VDE, VDE2, VDE2/A, VMA4, VME2, VME2/A, VME4, VM2, VM2/A, VWA, VWA2, VWA2/A, VWN2, VWN2/A, VW12, VW12/A, VW22, V1, W1, W1/A
			6	-	-	1283257	SWC4
			7	-	-		QAB1, QAB3, QAB3/A, QAE6, QAE6/A, QX26, QX26/A
			4	-	-	1283258	1340169 SWC4
			4	-	-		WMA4
			5	-	-	1340170	SWC4
20	90050-ZE1-000	SCREW, TAPPING, 5X8	(1)	-	-		LHQ4, QAQ4, QAQ4/A, QHE4, QHE4/A, QHQ4, QHQ4/A, QHR, QHR/A, QHR4, QHR4/A, RHE4, RHE4/A, RHQ4, RHQ4/A, SHQ4, SHQ4/A, SKE1, SWC4, SWC4/A, VMA4, VME4, WMA4
21	90050-ZH8-W40	SCREW, TAPPING, 5X25	(2)	-	-		LHQ4, QAQ4, QAQ4/A, QHE4, QHE4/A, QHQ4, QHQ4/A, QHR, QHR/A, QHR4, QHR4/A, RHE4, RHE4/A, RHQ4, RHQ4/A, SHQ4, SHQ4/A, SKE1, SWC4, SWC4/A, VMA4, VME4, WMA4

Ref. No.	Part No.	Description	Reqd. QTY			Serial No.	Parts catalogue code
			(1)	(2)	(3)		
22	90055-ZE1-000	SCREW, TAPPING, 4X6	3	-	3		HA, HAP, HAP/A, HAQ, HA2, HA2/A, HEA, HEA2, HEA2/A, HEA8, HEA8/A, LSS, LT, LT/A, LW, LW/A, PA, PAE2, PAE2/A, PA2, PA2/A, QA, QAB1, QAB3, QAB3/A, QAE, QAE2, QAE2/A, QAE6, QAE6/A, QAG, QAG/A, QAQ, QAQ4, QAQ4/A, QAR2, QAR2/A, QA2, QA2/A, QL2, QMH, QMH/A, QP, QP/A, QT, QT/A, QX26, QX26/A, RA, RA2, RA2/A, RSS, RSS/A, SMD, SW, SWE, VA, VAG2, VAG2/A, VAW, VA2, VA2/A, VDE, VDE2, VDE2/A, VMA4, VME4, VWA, VWA2, VWA2/A, VWN2, VWN2/A, VW22
23	90302-KF9-900	NUT, HEX., 5MM	-	(3)	-		LHQ4, QAAQ4, QAAQ4/A, QHE4, QHE4/A, QHQ4, QHQ4/A, QHR, QHR/A, QHR4, QHR4/A, RHE4, RHE4/A, RHQ4, RHQ4/A, SHQ4, SHQ4/A, SKE1, SWC4, SWC4/A, VMA4, VME4, WMA4
24	93891-05012-00	SCREW-WASHER, 5X12	(1)	-	-		LHQ4, QAAQ4, QAAQ4/A, QHE4, QHE4/A, QHQ4, QHQ4/A, QHR, QHR/A, QHR4, QHR4/A, RHE4, RHE4/A, RHQ4, RHQ4/A, SHQ4, SHQ4/A, SKE1, SWC4, SWC4/A, VMA4, VME4, WMA4
25	93891-06020-07	SCREW-WASHER, 6X20	(3)	-	-		LHQ4, QAAQ4, QAAQ4/A, QHE4, QHE4/A, QHQ4, QHQ4/A, QHR, QHR/A, QHR4, QHR4/A, RHE4, RHE4/A, RHQ4, RHQ4/A, SHQ4, SHQ4/A, VMA4, VME4, WMA4
26	94050-08000	NUT, FLANGE, 8MM	2	(3)	-		Q2, VMS2, VMX2
			5	(5)	5		HA, HAP, HAP/A, HAQ, HA2, HA2/A, HEA, HEA2, HEA2/A, HEA8, HEA8/A, HH, LH, LH/A, LHB1, LHB3, LHB5, LHE, LHE/A, LHQ4, LJ, LJ/A, LJC, LJC/A, LJG, LJG/A, LSS, LT, LT/A, LW, LW/A, LWD, L1, L1/A, PA, PAE2, PAE2/A, PA2, PA2/A, QA, QAB1, QAB3, QAB3/A, QAE, QAE2, QAE2/A, QAE6, QAE6/A, QAG, QAG/A, QAG2, QAG2/A, QAQ, QAAQ4, QAAQ4/A, QAR2, QAR2/A, QA2, QA2/A, QD, QD/A, QH, QH/A, QHB5, QHC, QHE, QHE4, QHE4/A, QHP1, QHP1/A, QHQ4, QHQ4/A, QHR, QHR/A, QHR4, QHR4/A, QHZ, QHZ/A, QH26, QH26/A, QL2, QMH, QMH/A, QP, QP/A, QT, QT/A, QX26, QX26/A, Q1, Q1/A, RA, RA2, RA2/A, RD, RD/A, RH, RHE, RHE4, RHE4/A, RHQ4, RHQ4/A, RH26, RH26/A, RSS, RSS/A, R1, R1/A, SD, SD/A, SH, SH/A, SHE, SHEZ, SHQ4, SHQ4/A, SJ, SJ/A, SJG, SJG/A, SK, SKE1, SMD, SMX2, SN, SN/A, SW, SWE, S1, S1/A, VA, VAG2, VAG2/A, VAW, VAW1, VA2, VA2/A, VDE, VDE2, VDE2/A, VH, VMA4, VME2, VME2/A, VME4, VM2, VM2/A, VWA, VWA2, VWA2/A, VWN2, VWN2/A, VW12, VW12/A, VW22, V1, WMA4, WMT8, WMT8/A, WXE8, WXE8/A, W1, W1/A
			5	-	-	1283257	SWC4
			3	-	-		SWC4/A
			3	-	-	1283258	SWC4
27	94103-05700	WASHER, PLAIN, 5MM	(3)	-	-		LHQ4, QAAQ4, QAAQ4/A, QHE4, QHE4/A, QHQ4, QHQ4/A, QHR, QHR/A, QHR4, QHR4/A, RHE4, RHE4/A, RHQ4, RHQ4/A, SHQ4, SHQ4/A, SKE1, SWC4, SWC4/A, VMA4, VME4, WMA4
28	94111-05000	WASHER, SPRING, 5MM	(1)	-	-		LHQ4, QAAQ4, QAAQ4/A, QHE4, QHE4/A, QHQ4, QHQ4/A, QHR, QHR/A, QHR4, QHR4/A, RHE4, RHE4/A, RHQ4, RHQ4/A, SHQ4, SHQ4/A, SKE1, SWC4, SWC4/A, VMA4, VME4, WMA4
29	90050-ZE1-000	SCREW, TAPPING, 5X8	1	-	-		QA, QAE, QAG, QAG/A, QA2/A, QL2, SMX2, VA, VAG2, VAG2/A, VAW, VAW1, VDE, VDE2, VDE2/A, VMA4, VME2, VME2/A, VME4, VM2, VM2/A, VWA
	90055-ZE1-000	SCREW, TAPPING, 4X6	(1)	-	-		HA, HEA, PA, RA
			1	(1)	(1)		HAP, HAP/A, HAQ, HA2, L1, L1/A, PA2, QA, QAB1, QAB3, QAE, QAE2, QAE6, QAQ, QAAQ4, QAR2, QA2, QX26, Q1, Q1/A, Q2, RA2, RSS, R1, R1/A, SWC4/A, VA2, VWA2, VWN2, VW12, VW12/A, VW22, V1, W1, W1/A
			1	-	-	1340170	SWC4
			(1)	-	-		HA2/A, HEA2, HEA2/A, HEA8, HEA8/A, PA2/A, QAB3/A, QAE2/A, QAE6/A, QAAQ4/A, QAR2/A, QX26/A, RA2/A, RSS/A, VA2/A, VWA2/A, VWN2/A
30	18323-ZE2-W60	PROTECTOR, EX. PIPE (100DB)	1	-	-		SWC4/A
			1	-	-	1283258	SWC4



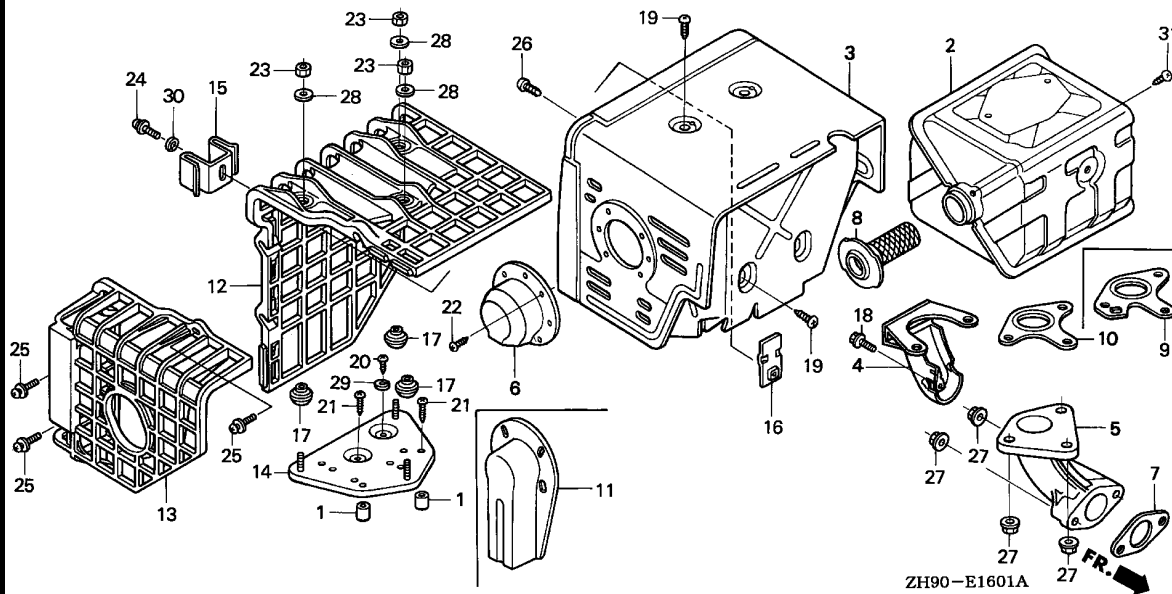

Ref. No.	L.O.N.	(Relative ref. Number) Description	F.R.T.
2	3131C5	MUFFLER, EXHAUST	0.2
3	3131D6	PROTECTOR, EXHAUST MUFFLER ...	0.2
5	3131C9	PIPE, EXHAUST	0.2
7	3131B5	GASKET, EXHAUST PIPE	0.2
8	3131A1	ARRESTER, SPARK	0.2
		.INCLUDES: Spark arrester check (9)	
10	3131B4	GASKET, EXHAUST MUFFLER	0.2
12	3131A7	COVER, EXHAUST MUFFLER	0.1
13	3131K6	COVER, EXHAUST MUFFLER :RIGHT	0.1
14	3131A2	BASE, EXHAUST MUFFLER COVER ..	0.2

Ref. No.	Part No.	Description	Reqd. QTY			Serial No.	Parts catalogue code
			(1)	(2)	(3)		
1	17233-896-701	COLLAR, AIR CLEANER CASE	2	-	-	-----	HXQ4/A, LXQ4/A, QKE3/A, QKE4, QME2/A, QWA4/A, QXC4/A, QXE4/A, QXQ4/A, RXQ4/A, SMC4/A, SME1/A, SME6/A, SWA4, SXE4/A, SXQ4/A, VN17/A, VSH7, VWT4/A, VXE4/A, VXQ4/A
2	18310-ZE2-W61	MUFFLER COMP. (100DB)	1	-	1	-----	ES1, ES1/A, HX, HX/A, HXQ4, HXQ4/A, HX26, HX26/A, HX8, HX8/A, LTJ, LWD1, LWD1/A, LX, LX/A, LXE, LXE/A, LXE8, LXE8/A, LXQ4, LXQ4/A, LXU, LXU/A, LXZ, LX16, PX, PX/A, PXE8, PXE8/A, PXU, PXU/A, PX26, PX26/A, QE, QE/A, QKE3, QKE3/A, QKE4, QME2, QME2/A, QSC, QSC9, QSC9/A, QSE, QSE/A, QSE2, QSE8, QSE8/A, QWA2, QWA4, QWA4/A, QWH2, QWH2/A, QX, QX/A, QXB, QXB/A, QXB6, QXB6/A, QXB7, QXB7/A, QXC, QXC4, QXC4/A, QXC6, QXC6/A, QXC9, QXC9/A, QXE, QXE/A, QXEB, QXE4, QXE4/A, QXE6, QXE6/A, QXE8, QXE8/A, QXQ4, QXQ4/A, QXU, QXU/A, RSC2, RSC2/A, RX, RX/A, RXP, RXP/A, RXQ4, RXQ4/A, RXU, RXU/A, SE, SE/A, SMC4, SMC4/A, SME1, SME1/A, SME6, SME6/A, SWA4, SX, SX/A, SXB, SXB/A, SXB7, SXB7/A, SXE, SXE/A, SXEB, SXEB/A, SXE4, SXE4/A, SXE8, SXE8/A, SXQ4, SXQ4/A, SXU, SXU/A, SX2, VD16, VEB6, VKB2, VKB2/A, VNG1, VNG1/A, VNT2, VNT2/A, VN17, VN17/A, VSD, VSD/A, VSD7, VSD7/A, VSH7, VX, VX/A, VXB, VXB/A, VXB2, VXB6, VXB7, VXB7/A, VXE, VXEB, VXEB/A, VXE4, VXE4/A, VXE6, VXE6/A, VXE7, VXE7/A, VXG, VXP, VXP/A, VXQP, VXQ4, VXQ4/A, VXTB, VXT1, VXT1/A, VXU, VXU/A, VXU1, VXU1/A, VX26
			-	(1)	-		

Ref. No.	Part No.	Description	Reqd. QTY			Serial No.	Parts catalogue code
			(1)	GX270 (2)	(3)		
3	18320-ZE2-W61	PROTECTOR COMP., MUFFLER	1	-	1	-----	ES1,ES1/A,HX,HX/A,HXQ4,HXQ4/A,HX26,HX26/A,HX8,HX8/A,LTJ,LWD1 LWD1/A,LX,LX/A,LXE,LXE/A,LXE8,LXE8/A,LXQ4,LXQ4/A,LXU,LXU/A,LXZ LX16,PX,PX/A,PXE8,PXE8/A,PXU,PXU/A,PX26,PX26/A,QE,QE/A,QME2 QME2/A,QSC,QSC9,QSC9/A,QSE,QSE/A,QSE2,QSE8,QSE8/A,QWA2,QWA4 QWA4/A,QWH2,QWH2/A,QX,QX/A,QXB,QXB/A,QXB6,QXB6/A,QXC,QXC4,QXC4/A QXC6,QXC6/A,QXC9,QXC9/A,QXE,QXE/A,QXEB,QXE4,QXE4/A,QXE6,QXE6/A QXE8,QXE8/A,QXQ4,QXQ4/A,QXU,QXU/A,RSC2,RSC2/A,RX,RX/A,RXP,RXP/A RXQ4,RXQ4/A,RXU,RXU/A,SE,SE/A,SMC4,SMC4/A,SME1,SME1/A,SME6,SME6/A SWA4,SX,SX/A,SXB,SXB/A,SXE,SXE/A,SXEB,SXEB/A,SXE4,SXE4/A,SXE8 SXE8/A,SXQ4,SXQ4/A,SXU,SXU/A,SX2,VD16,VEB6,VKB2,VKB2/A,VNG1 VNG1/A,VNT2,VNT2/A,VSD,VSD/A,VX,VX/A,VXB,VXB/A,VXB2,VXB6,VXE,VXEB VXEB/A,VXE4,VXE4/A,VXE6,VXE6/A,VXG,VXP,VXP/A,VXQP,VXQ4,VXQ4/A VXTB,VXT1,VXT1/A,VXU,VXU/A,VXU1,VXU1/A,VX26
	18320-ZF6-W01	PROTECTOR COMP., MUFFLER (100DB)	1	-	-	-----	QXB7,QXB7/A,SXB7,SXB7/A,VN17,VN17/A,VSD7,VSD7/A,VSH7,VXB7,VXB7/A VXE7,VXE7/A
4	18323-ZE2-W60	PROTECTOR, EX. PIPE (100DB)	1	-	-	-----	LTJ,LWD1,LWD1/A,RSC2,RSC2/A,SWA4,VKB2,VKB2/A,VNT2,VNT2/A
5	18330-ZH9-N00	PIPE, EX.	1	-	1	-----	ES1,ES1/A,HX,HX/A,HXQ4,HXQ4/A,HX26,HX26/A,HX8,HX8/A,LTJ,LWD1 LWD1/A,LX,LX/A,LXE,LXE/A,LXE8,LXE8/A,LXQ4,LXQ4/A,LXU,LXU/A,LXZ LX16,PX,PX/A,PXE8,PXE8/A,PXU,PXU/A,PX26,PX26/A,QE,QE/A,QME2 QME2/A,QSC,QSC9,QSC9/A,QSE,QSE/A,QSE2,QSE8,QSE8/A,QWA2,QWA4 QWA4/A,QWH2,QWH2/A,QX,QX/A,QXB,QXB/A,QXB6,QXB6/A,QXB7,QXB7/A,QXC QXC4,QXC4/A,QXC6,QXC6/A,QXC9,QXC9/A,QXE,QXE/A,QXEB,QXE4,QXE4/A QXE6,QXE6/A,QXE8,QXE8/A,QXQ4,QXQ4/A,QXU,QXU/A,RSC2,RSC2/A,RX,RX/A RXP,RXP/A,RXQ4,RXQ4/A,RXU,RXU/A,SE,SE/A,SMC4,SMC4/A,SME1,SME1/A SME6,SME6/A,SWA4,SX,SX/A,SXB,SXB/A,SXB7,SXB7/A,SXE,SXE/A,SXEB SXEB/A,SXE4,SXE4/A,SXE8,SXE8/A,SXQ4,SXQ4/A,SXU,SXU/A,SX2,VD16 VEB6,VKB2,VKB2/A,VNG1,VNG1/A,VNT2,VNT2/A,VN17,VN17/A,VSD,VSD/A VSD7,VSD7/A,VSH7,VX,VX/A,VXB,VXB/A,VXB2,VXB6,VXB7,VXB7/A,VXE,VXEB VXEB/A,VXE4,VXE4/A,VXE6,VXE6/A,VXE7,VXE7/A,VXG,VXP,VXP/A,VXQP VXQ4,VXQ4/A,VXTB,VXT1,VXT1/A,VXU,VXU/A,VXU1,VXU1/A,VX26
6	18331-ZE2-810	CAP, MUFFLER	1	(1)	-	-----	LTJ,L1,L1/A,QE,QE/A,QWA2,QWA4,QWA4/A,QWH2,QWH2/A,Q1,Q1/A,Q2,R1 R1/A,SE,SE/A,VKB2,VKB2/A,VNT2,VNT2/A,V1,W1,W1/A
7	18333-ZE3-000	GASKET, EX. PIPE	1	(1)	-	-----	1031041 LXZ,L1,Q1,R1,S1,V1,W1
	18333-ZE3-800	1	-	-	-----	VPE5,VPX5,VWT4,VWT4/A
			1	-	-	-----	1187115 HX,HXQ4,HX26,LTJ,LX,LXE,LXQ4,LX16,PX,PX26,QE,QME2,QSC,QSC9,QX,QXB QXC,QXC4,QXC6,QXC9,QXE,QXEB,QXE4,QXE6,QXQ4,RSC2,RX,RXQ4,SE,SMC4 SME1,SME6,SX,SXB,SXE,SXEB,SXE4,SXQ4,SX2,VD16,VEB6,VNG1,VSD,VX,VXB VXB2,VXB6,VXE,VXEB,VXE4,VXG,VXQ4,VXU,VX26
			1	-	-	-----	1031042 1187115 LXZ
			-	(1)	-	-----	
			-	-	1	-----	1000009 VXP,VXQP
	18333-ZK6-Y00	1	-	-	-----	QKE3,QKE3/A,QKE4
			1	-	-	-----	1187116 LXZ,QSC,QXC,QXEB,SX2,VEB6,VXB6
			1	-	-	-----	1457779 ES1,HX8,LXE8,LXU,PXU,QSE,QSE8,QXB6,QXE8,QXU,RXU,SXE8,SXU,VKB2 VNT2,VXE6,VXTB,VXT1,VXU1
			1	-	-	-----	1187116 1457779 HX,HXQ4,HX26,LTJ,LX,LXE,LXQ4,LX16,PX,PX26,QE,QME2,QSC9,QX,QXB QXC4,QXC6,QXC9,QXE,QXE4,QXE6,QXQ4,RSC2,RX,RXQ4,SE,SMC4,SME1,SME6 SX,SXB,SXE,SXEB,SXE4,SXQ4,VD16,VNG1,VSD,VX,VXB,VXB2,VXE,VXEB,VXE4 VXG,VXQ4,VXU,VX26
			-	(1)	-	-----	
			-	-	1	-----	1000010 1000085 VXP,VXQP



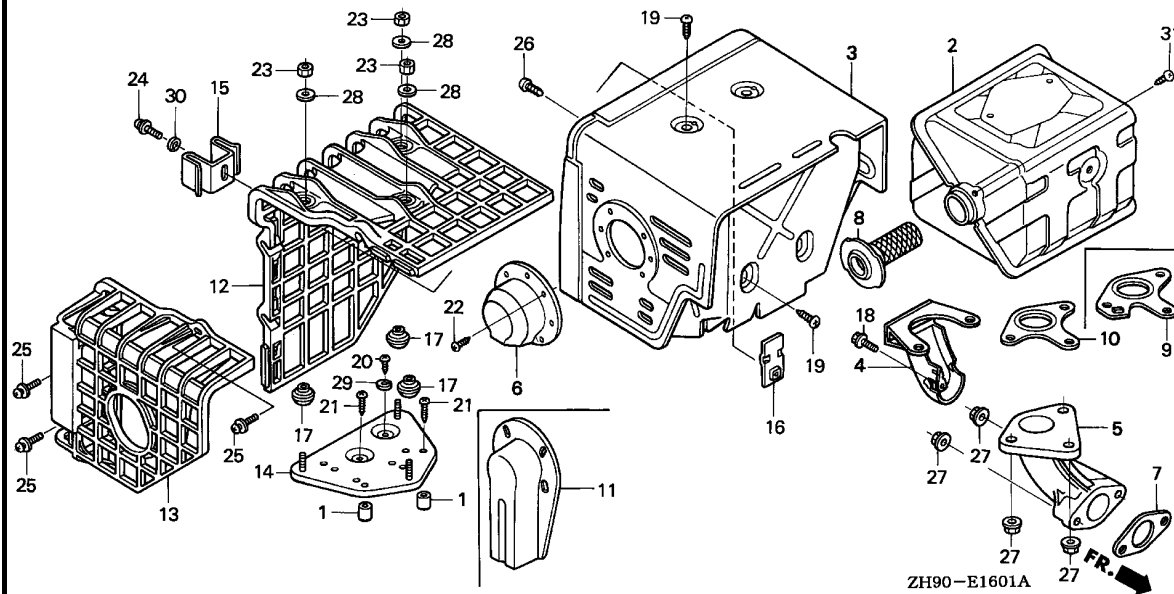

Ref. No.	Part No.	Description	Reqd. QTY			Serial No.	Parts catalogue code	
			(1)	(2)	(3)			
(7)	18333-ZF6-W01	GASKET, EX. PIPE	1	-	1	-----	ES1/A, HX/A, HXQ4/A, HX26/A, HX8/A, LWD1, LWD1/A, LX/A, LXE/A, LXE8/A, LXQ4/A, LXU/A, PX/A, PXE8, PXE8/A, PXU/A, PX26/A, QE/A, QME2/A, QSC9/A, QSE/A, QSE2, QSE8/A, QWA4, QWA4/A, QWH2, QWH2/A, QX/A, QXB/A, QXB6/A, QXB7, QXB7/A, QXC4/A, QXC6/A, QXC9/A, QXE/A, QXE4/A, QXE6/A, QXE8/A, QXQ4/A, QXU/A, RSC2/A, RX/A, RXP, RXP/A, RXQ4/A, RXU/A, SE/A, SMC4/A, SME1/A, SME6/A, SWA4, SX/A, SXB/A, SXB7, SXB7/A, SXE/A, SXEB/A, SXE4/A, SXE8/A, SXQ4/A, SXU/A, VKB2/A, VNG1/A, VNT2/A, VN17, VN17/A, VSD/A, VSD7, VSD7/A, VSH7, VX/A, VXB/A, VXB7, VXB7/A, VXEB/A, VXE4/A, VXE6/A, VXE7, VXE7/A, VXP/A, VXQ4/A, VXT1/A, VXU/A, VXU1/A	
			1	-	-	1457780	-----	ES1, HX, HXQ4, HX26, HX8, LTJ, LX, LXE, LXE8, LXQ4, LXU, LX16, PX, PXU, PX26, QE, QME2, QSC9, QSE, QSE8, QX, QXB, QXB6, QXC4, QXC6, QXC9, QXE, QXE4, QXE8, QXQ4, QXU, RSC2, RX, RXQ4, RXU, SE, SMC4, SME1, SME6, SX, SXB, SXE, SXEB, SXE4, SXE8, SXQ4, SXU, VD16, VKB2, VNG1, VNT2, VSD, VX, VXB, VXB2, VXE, VXEB, VXE4, VXE6, VXG, VXQ4, VXTB, VXT1, VXU, VXU1, VX26
8	18355-ZE2-W00	ARRESTER, SPARK	1	-	-	1000086	-----	VXP, VXQP QE, QE/A, QXB, QXB/A, QXB7, QXB7/A, QXEB, SE, SE/A, SMC4, SMC4/A, SXB, SXB/A, SXB7, SXB7/A, SXEB, SXEB/A, VD16, VEB6, VKB2, VKB2/A, VNG1, VNG1/A, VNT2, VNT2/A, VN17, VN17/A, VPE5, VPE5, VSD, VSD/A, VSD7, VSD7/A, VSH7, VXB, VXB/A, VXB2, VXB6, VXB7, VXB7/A, VXEB, VXEB/A, VXE7, VXE7/A, VXG, VXTB, HXQ4, HXQ4/A, HX26, HX26/A, QSC, QSC9, QSC9/A, QSE2, QWA2, QWA4/A, QWH2, QWH2/A, QXC, QXC4, QXC4/A, QXC6, QXC6/A, QXC9, QXC9/A
	18355-ZE2-010	(1)	-	-	-----	-----	RSC2, RSC2/A

2

Ref. No.	Part No.	Description	Reqd. QTY			Serial No.	Parts catalogue code
			(1)	(2)	(3)		
9	18381-ZE2-W10	GASKET, MUFFLER (ARRESTER) ..	1	-	-	-----	LTJ, LWD1, LWD1/A, QE, QE/A, QXB, QXB/A, QXB7, QXB7/A, QXEB, RSC2, RSC2/A, SE SE/A, SMC4, SMC4/A, SWA4, SXB, SXB/A, SXB7, SXB7/A, SXEB, SXEB/A, VD16, VEB6 VKB2, VKB2/A, VNG1, VNG1/A, VNT2, VNT2/A, VN17, VN17/A, VSD, VSD/A, VSD7 VSD7/A, VSH7, VXB, VXB/A, VXB2, VXB6, VXB7, VXB7/A, VXE7, VXE7/A, VXE7 VXE7/A, VXG, VXTB
			(1)	-	-	-----	HXQ4, HXQ4/A, HX26, HX26/A, QSC, QSC9, QSC9/A, QSE2, QWA2, QWA4, QWA4/A QWH2, QWH2/A, QXC, QXC4, QXC4/A, QXC6, QXC6/A, QXC9, QXC9/A
10	18381-ZE2-800	GASKET, MUFFLER	1	-	1	-----	ES1, ES1/A, HX, HX/A, HXQ4, HXQ4/A, HX26, HX26/A, HX8, HX8/A, LX, LX/A, LXE LXE/A, LXE8, LXE8/A, LXQ4, LXQ4/A, LXU, LXU/A, LXZ, LX16, PX, PX/A, PXE8 PXE8/A, PXU, PXU/A, PX26, PX26/A, QKE3, QKE3/A, QKE4, QME2, QME2/A, QSC QSC9, QSC9/A, QSE, QSE/A, QSE2, QSE8, QSE8/A, QWA2, QWA4, QWA4/A, QWH2 QWH2/A, QX, QX/A, QXB6, QXB6/A, QXC, QXC4, QXC4/A, QXC6, QXC6/A, QXC9 QXC9/A, QXE, QXE/A, QXE4, QXE4/A, QXE6, QXE6/A, QXE8, QXE8/A, QXQ4, QXQ4/A QXU, QXU/A, RX, RX/A, RXP, RXP/A, RXQ4, RXQ4/A, RXU, RXU/A, SME1, SME1/A SME6, SME6/A, SX, SX/A, SXE, SXE/A, SXE4, SXE4/A, SXE8, SXE8/A, SXQ4, SXQ4/A SXU, SXU/A, SX2, VX, VX/A, VXE, VXE4, VXE4/A, VXE6, VXE6/A, VXP, VXP/A, VXQP VXQ4, VXQ4/A, VXT1, VXT1/A, VXU, VXU/A, VXU1, VXU1/A, VX26
			-	(1)	-	-----	
11	18430-ZF6-W50	DEFLECTOR COMP., MUFFLER	(1)	-	-	-----	QE, QE/A, SE, SE/A
12	18433-ZF6-W40	COVER COMP., MUFFLER	(1)	-	(1)	-----	HXQ4, HXQ4/A, LXQ4, LXQ4/A, QE, QE/A, QKE3, QKE3/A, QKE4, QME2, QME2/A, QWA4 QWA4/A, QXB, QXB/A, QXB7, QXB7/A, QXC4, QXC4/A, QXE4, QXE4/A, QXQ4, QXQ4/A RXQ4, RXQ4/A, SE, SE/A, SMC4, SMC4/A, SME1, SME1/A, SME6, SME6/A, SWA4, SXB SXB/A, SXB7, SXB7/A, SXEB, SXEB/A, SXE4, SXE4/A, SXQ4, SXQ4/A, VD16, VEB6 VNG1, VNG1/A, VN17, VN17/A, VSD, VSD/A, VSD7, VSD7/A, VSH7, VWT4, VWT4/A VXB, VXB/A, VXB7, VXB7/A, VXEB, VXEB/A, VXE4, VXE4/A, VXE7, VXE7/A, VXG VXQP, VXQ4, VXQ4/A, VXTB
13	18434-ZF6-W40	COVER COMP., MUFFLER RR.	(1)	-	(1)	-----	HXQ4, HXQ4/A, LXQ4, LXQ4/A, QE, QE/A, QKE3, QKE3/A, QKE4, QME2, QME2/A, QWA4 QWA4/A, QXB, QXB/A, QXB7, QXB7/A, QXC4, QXC4/A, QXE4, QXE4/A, QXQ4, QXQ4/A RXQ4, RXQ4/A, SE, SE/A, SMC4, SMC4/A, SME1, SME1/A, SME6, SME6/A, SWA4, SXB SXB/A, SXB7, SXB7/A, SXEB, SXEB/A, SXE4, SXE4/A, SXQ4, SXQ4/A, VD16, VEB6 VNG1, VNG1/A, VN17, VN17/A, VSD, VSD/A, VSD7, VSD7/A, VSH7, VWT4, VWT4/A VXB, VXB/A, VXB7, VXB7/A, VXEB, VXEB/A, VXE4, VXE4/A, VXE7, VXE7/A, VXG VXQP, VXQ4, VXQ4/A, VXTB
14	18436-ZH8-W40	BASE COMP., MUFFLER COVER ...	(1)	-	(1)	-----	HXQ4, HXQ4/A, LXQ4, LXQ4/A, QE, QE/A, QKE3, QKE3/A, QKE4, QME2, QME2/A, QWA4 QWA4/A, QXB, QXB/A, QXB7, QXB7/A, QXC4, QXC4/A, QXE4, QXE4/A, QXQ4, QXQ4/A RXQ4, RXQ4/A, SE, SE/A, SMC4, SMC4/A, SME1, SME1/A, SME6, SME6/A, SWA4, SXB SXB/A, SXB7, SXB7/A, SXEB, SXEB/A, SXE4, SXE4/A, SXQ4, SXQ4/A, VD16, VEB6 VNG1, VNG1/A, VN17, VN17/A, VSD, VSD/A, VSD7, VSD7/A, VSH7, VWT4, VWT4/A VXB, VXB/A, VXB7, VXB7/A, VXEB, VXEB/A, VXE4, VXE4/A, VXE7, VXE7/A, VXG VXQP, VXQ4, VXQ4/A, VXTB
15	18437-ZF6-W40	STAY, MUFFLER COVER	(1)	-	(1)	-----	HXQ4, HXQ4/A, LXQ4, LXQ4/A, QE, QE/A, QKE3, QKE3/A, QKE4, QME2, QME2/A, QWA4 QWA4/A, QXB, QXB/A, QXB7, QXB7/A, QXC4, QXC4/A, QXE4, QXE4/A, QXQ4, QXQ4/A RXQ4, RXQ4/A, SE, SE/A, SMC4, SMC4/A, SME1, SME1/A, SME6, SME6/A, SWA4, SXB SXB/A, SXB7, SXB7/A, SXEB, SXEB/A, SXE4, SXE4/A, SXQ4, SXQ4/A, VD16, VEB6 VNG1, VNG1/A, VN17, VN17/A, VSD, VSD/A, VSD7, VSD7/A, VSH7, VWT4, VWT4/A VXB, VXB/A, VXB7, VXB7/A, VXEB, VXEB/A, VXE4, VXE4/A, VXE7, VXE7/A, VXG VXQP, VXQ4, VXQ4/A, VXTB
16	18438-ZF6-W40	PLATE, SET	(1)	-	(1)	-----	HXQ4, HXQ4/A, LXQ4, LXQ4/A, QE, QE/A, QKE3, QKE3/A, QKE4, QME2, QME2/A, QWA4 QWA4/A, QXB, QXB/A, QXB7, QXB7/A, QXC4, QXC4/A, QXE4, QXE4/A, QXQ4, QXQ4/A RXQ4, RXQ4/A, SE, SE/A, SMC4, SMC4/A, SME1, SME1/A, SME6, SME6/A, SWA4, SXB SXB/A, SXB7, SXB7/A, SXEB, SXEB/A, SXE4, SXE4/A, SXQ4, SXQ4/A, VD16, VEB6 VNG1, VNG1/A, VN17, VN17/A, VSD, VSD/A, VSD7, VSD7/A, VSH7, VWT4, VWT4/A VXB, VXB/A, VXB7, VXB7/A, VXEB, VXEB/A, VXE4, VXE4/A, VXE7, VXE7/A, VXG VXQP, VXQ4, VXQ4/A, VXTB



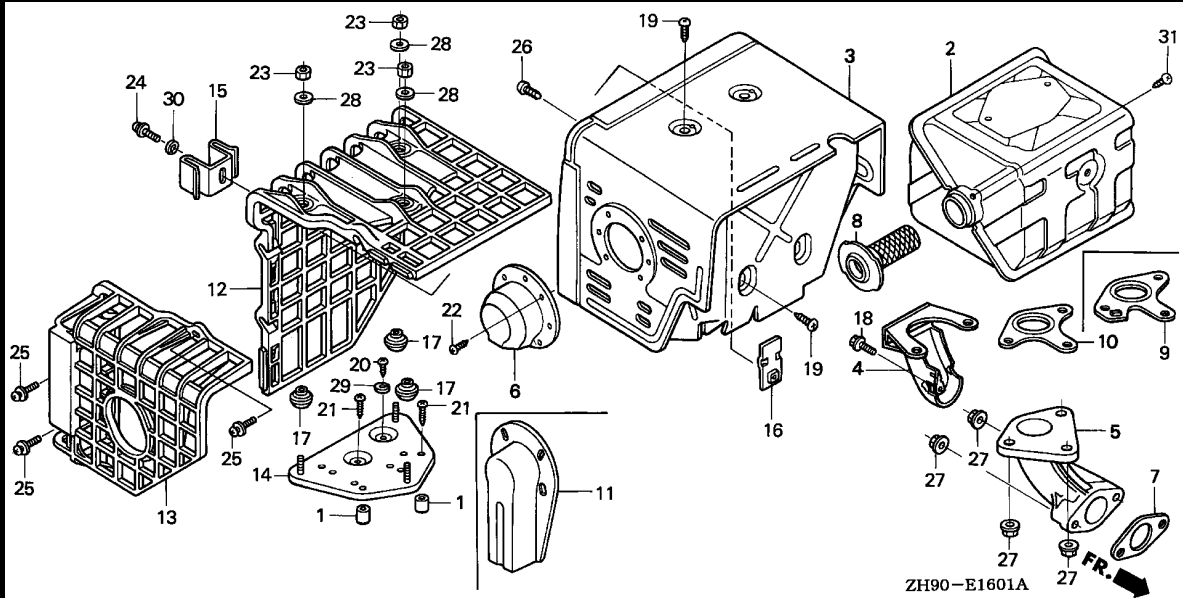

Ref. No.	Part No.	Description	Reqd. QTY			Serial No.	Parts catalogue code
			(1)	(2)	(3)		
17	18466-ZH8-W40	SPACER, MUFFLER COVER	(3)	-	(3)	-----	HXQ4, HXQ4/A, LXQ4, LXQ4/A, QE, QE/A, QKE3, QKE3/A, QKE4, QME2, QME2/A, QWA4, QWA4/A, QXB, QXB/A, QXB7, QXB7/A, QXC4, QXC4/A, QXE4, QXE4/A, QXQ4, QXQ4/A, RXQ4, RXQ4/A, SE, SE/A, SMC4, SMC4/A, SME1, SME1/A, SME6, SME6/A, SWA4, SXB, SXB/A, SXB7, SXB7/A, SXEB, SXEB/A, SXE4, SXE4/A, SXQ4, SXQ4/A, VD16, VEB6, VNG1, VNG1/A, VN17, VN17/A, VSD, VSD/A, VSD7, VSD7/A, VSH7, VWT4, VWT4/A, VXB, VXB/A, VXB7, VXB7/A, VXEB, VXEB/A, VXE4, VXE4/A, VXE7, VXE7/A, VXG, VXQP, VXQ4, VXQ4/A, VXTB
18	90013-883-000	BOLT, FLANGE, 6X12(CT200)	1	-	-	-----	LTJ, LWD1, LWD1/A, RSC2, RSC2/A, SWA4, VKB2, VKB2/A, VNT2, VNT2/A
19	90050-ZE1-000	SCREW, TAPPING, 5X8	4	(4)	4	-----	ES1, ES1/A, HX, HX/A, HXQ4, HXQ4/A, HX26, HX26/A, HX8, HX8/A, LTJ, LWD1, LWD1/A, LX, LX/A, LXQ4, LXQ4/A, LXU, LXU/A, LXZ, LXZ/A, LX16, LX16/A, PX, PX/A, PXE8, PXE8/A, PXU, PXU/A, PX26, PX26/A, QME2, QME2/A, QSC, QSC9, QSC9/A, QSE, QSE/A, QSE2, QSE8, QSE8/A, QWA2, QWA4, QWA4/A, QWH2, QWH2/A, QX, QX/A, QXB6, QXB6/A, QXC, QXC4, QXC4/A, QXC6, QXC6/A, QXC9, QXC9/A, QXE, QXE/A, QXE4, QXE4/A, QXE6, QXE6/A, QXE8, QXE8/A, QXQ4, QXQ4/A, QXU, QXU/A, Q1, Q1/A, RSC2, RSC2/A, RX, RX/A, RXP, RXP/A, RXQ4, RXQ4/A, RXU, RXU/A, R1, R1/A, SME1, SME1/A, SME6, SME6/A, SWA4, SX, SX/A, SXE, SXE/A, SXE4, SXE4/A, SXEB, SXEB/A, SXQ4, SXQ4/A, SXU, SXU/A, SX2, S1, S1/A, VKB2, VKB2/A, VNT2, VNT2/A, VX, VX/A, VXE, VXE4, VXE4/A, VXE6, VXE6/A, VXG, VXP, VXP/A, VXQP, VXQ4, VXQ4/A, VXT1, VXT1/A, VXU, VXU/A, VXU1, VXU1/A, VX26, V1, W1, W1/A
			5	(5)	-	-----	QE, QE/A, QXB, QXB/A, QXB7, QXB7/A, QXEB, Q2, SE, SE/A, SMC4, SMC4/A, SXB, SXB/A, SXB7, SXB7/A, SXEB, SXEB/A, VD16, VEB6, VNG1, VNG1/A, VN17, VN17/A, VSD, VSD/A, VSD7, VSD7/A, VSH7, VXB, VXB/A, VXB2, VXB6, VXB7, VXB7/A, VXEB, VXEB/A, VXE7, VXE7/A, VXTB

Ref. No.	Part No.	Description	Reqd. QTY			Serial No.	Parts catalogue code	
			(1)	(2)	(3)			
20	90050-ZE1-000	SCREW, TAPPING, 5X8	(1)	-	(1)	-----	HXQ4, HXQ4/A, LXQ4, LXQ4/A, QE, QE/A, QKE3, QKE3/A, QKE4, QME2, QME2/A, QWA4, QWA4/A, QXB, QXB/A, QXB7, QXB7/A, QXC4, QXC4/A, QXE4, QXE4/A, QXQ4, QXQ4/A, RXQ4, RXQ4/A, SE, SE/A, SMC4, SMC4/A, SME1, SME1/A, SME6, SME6/A, SWA4, SXB, SXB/A, SXB7, SXB7/A, SXEB, SXEB/A, SXE4, SXE4/A, SXQ4, SXQ4/A, VD16, VEB6, VNG1, VNG1/A, VN17, VN17/A, VSD, VSD/A, VSD7, VSD7/A, VSH7, VWT4, VWT4/A, VXB, VXB/A, VXB7, VXB7/A, VXEB, VXEB/A, VXE4, VXE4/A, VXE7, VXE7/A, VXG, VXQP, VXQ4, VXQ4/A, VXTB	
21	90050-ZH8-W40	SCREW, TAPPING, 5X25	(2)	-	(2)	-----	HXQ4, HXQ4/A, LXQ4, LXQ4/A, QE, QE/A, QKE3, QKE3/A, QKE4, QME2, QME2/A, QWA4, QWA4/A, QXB, QXB/A, QXB7, QXB7/A, QXC4, QXC4/A, QXE4, QXE4/A, QXQ4, QXQ4/A, RXQ4, RXQ4/A, SE, SE/A, SMC4, SMC4/A, SME1, SME1/A, SME6, SME6/A, SWA4, SXB, SXB/A, SXB7, SXB7/A, SXEB, SXEB/A, SXE4, SXE4/A, SXQ4, SXQ4/A, VD16, VEB6, VNG1, VNG1/A, VN17, VN17/A, VSD, VSD/A, VSD7, VSD7/A, VSH7, VWT4, VWT4/A, VXB, VXB/A, VXB7, VXB7/A, VXEB, VXEB/A, VXE4, VXE4/A, VXE7, VXE7/A, VXG, VXQP, VXQ4, VXQ4/A, VXTB	
22	90055-ZE1-000	SCREW, TAPPING, 4X6	3	(3)	-	-----	LTJ, L1, L1/A, QE, QE/A, QWA2, QWA4, QWA4/A, QWH2, QWH2/A, Q1, Q1/A, Q2, R1, R1/A, SE, SE/A, VKB2, VKB2/A, VNT2, VNT2/A, V1, W1, W1/A	
23	90302-KF9-900	NUT, HEX., 5MM	(3)	-	(3)	-----	HXQ4, HXQ4/A, LXQ4, LXQ4/A, QE, QE/A, QKE3, QKE3/A, QKE4, QME2, QME2/A, QWA4, QWA4/A, QXB, QXB/A, QXB7, QXB7/A, QXC4, QXC4/A, QXE4, QXE4/A, QXQ4, QXQ4/A, RXQ4, RXQ4/A, SE, SE/A, SMC4, SMC4/A, SME1, SME1/A, SME6, SME6/A, SWA4, SXB, SXB/A, SXB7, SXB7/A, SXEB, SXEB/A, SXE4, SXE4/A, SXQ4, SXQ4/A, VD16, VEB6, VNG1, VNG1/A, VN17, VN17/A, VSD, VSD/A, VSD7, VSD7/A, VSH7, VWT4, VWT4/A, VXB, VXB/A, VXB7, VXB7/A, VXEB, VXEB/A, VXE4, VXE4/A, VXE7, VXE7/A, VXG, VXQP, VXQ4, VXQ4/A, VXTB	
24	93891-05012-00	SCREW-WASHER, 5X12	(1)	-	(1)	-----	HXQ4, HXQ4/A, LXQ4, LXQ4/A, QE, QE/A, QKE3, QKE3/A, QKE4, QME2, QME2/A, QWA4, QWA4/A, QXB, QXB/A, QXB7, QXB7/A, QXC4, QXC4/A, QXE4, QXE4/A, QXQ4, QXQ4/A, RXQ4, RXQ4/A, SE, SE/A, SMC4, SMC4/A, SME1, SME1/A, SME6, SME6/A, SWA4, SXB, SXB/A, SXB7, SXB7/A, SXEB, SXEB/A, SXE4, SXE4/A, SXQ4, SXQ4/A, VD16, VEB6, VNG1, VNG1/A, VN17, VN17/A, VSD, VSD/A, VSD7, VSD7/A, VSH7, VWT4, VWT4/A, VXB, VXB/A, VXB7, VXB7/A, VXEB, VXEB/A, VXE4, VXE4/A, VXE7, VXE7/A, VXG, VXQP, VXQ4, VXQ4/A, VXTB	
25	93891-06020-07	SCREW-WASHER, 6X20	(3)	-	(3)	-----	HXQ4, HXQ4/A, LXQ4, LXQ4/A, QE, QE/A, QKE3, QKE3/A, QKE4, QME2, QME2/A, QWA4, QWA4/A, QXB, QXB/A, QXB7, QXB7/A, QXC4, QXC4/A, QXE4, QXE4/A, QXQ4, QXQ4/A, RXQ4, RXQ4/A, SE, SE/A, SMC4, SMC4/A, SME1, SME1/A, SME6, SME6/A, SWA4, SXB, SXB/A, SXB7, SXB7/A, SXEB, SXEB/A, SXE4, SXE4/A, SXQ4, SXQ4/A, VD16, VEB6, VNG1, VNG1/A, VN17, VN17/A, VSD, VSD/A, VSD7, VSD7/A, VSH7, VWT4, VWT4/A, VXB, VXB/A, VXB7, VXB7/A, VXEB, VXEB/A, VXE4, VXE4/A, VXE7, VXE7/A, VXG, VXQP, VXQ4, VXQ4/A, VXTB	
26	90006-ZE2-000	SCREW, TAPPING, 6X10	1	(1)	1	-----	ES1, ES1/A, HX/A, HXQ4, HXQ4/A, HX26, HX26/A, HX8, HX8/A, LTJ, LWD1, LWD1/A, LX/A, LXE, LXE/A, LXE8, LXE8/A, LXQ4, LXQ4/A, LXU, LXU/A, LX16, L1/A, PX/A, PXE8, PXE8/A, PXU, PXU/A, PX26, PX26/A, QE/A, QME2, QME2/A, QSC, QSC9, QSC9/A, QSE, QSE/A, QSE2, QSE8, QSE8/A, QWA2, QWA4, QWA4/A, QWH2, QWH2/A, QX/A, QXB/A, QXB6, QXB6/A, QXB7, QXB7/A, QXC4, QXC4/A, QXC6, QXC6/A, QXC9, QXC9/A, QXE/A, QXE4, QXE4/A, QXE6, QXE6/A, QXE8, QXE8/A, QXQ4, QXQ4/A, QXU, QXU/A, Q1/A, RSC2, RSC2/A, RX/A, RXP, RXP/A, RXQ4, RXQ4/A, RXU, RXU/A, R1/A, SE/A, SMC4, SMC4/A, SME1, SME1/A, SME6, SME6/A, SWA4, SX/A, SXB/A, SXB7, SXB7/A, SXE/A, SXEB/A, SXE4, SXE4/A, SXE8, SXE8/A, SXQ4, SXQ4/A, SXU, SXU/A, SX2, S1/A, VD16, VEB6, VKB2, VKB2/A, VNG1/A, VNT2, VNT2/A, VN17, VN17/A, VSD/A, VSD7, VSD7/A, VSH7, VX/A, VXB/A, VXB2, VXB6, VXB7, VXB7/A, VXEB/A, VXE4, VXE4/A, VXE6, VXE6/A, VXE7, VXE7/A, VXG, VXP, VXP/A, VXQP, VXQ4, VXQ4/A, VXTB, VXT1, VXT1/A, VXU, VXU/A, VXU1, VXU1/A, VX26, W1/A	
	93901-360J0	1	(1)	-	1047506	-----	HX, LX, LXZ, L1, PX, QE, QX, QXB, QXC, QXE, QXEB, Q1, RX, R1, SE, SX, SXB, SXE, SXEB, S1, VNG1, VSD, VX, VXB, VXE, VXEB, V1, W1
			-	(1)	-	-----	-----	HX, LX, LXZ, L1, PX, QE, QX, QXB, QXC, QXE, QXEB, Q1, RX, R1, SE, SX, SXB, SXE, SXEB, S1, VNG1, VSD, VX, VXB, VXE, VXEB, V1, W1
			-	(1)	-	-----	-----	Q2



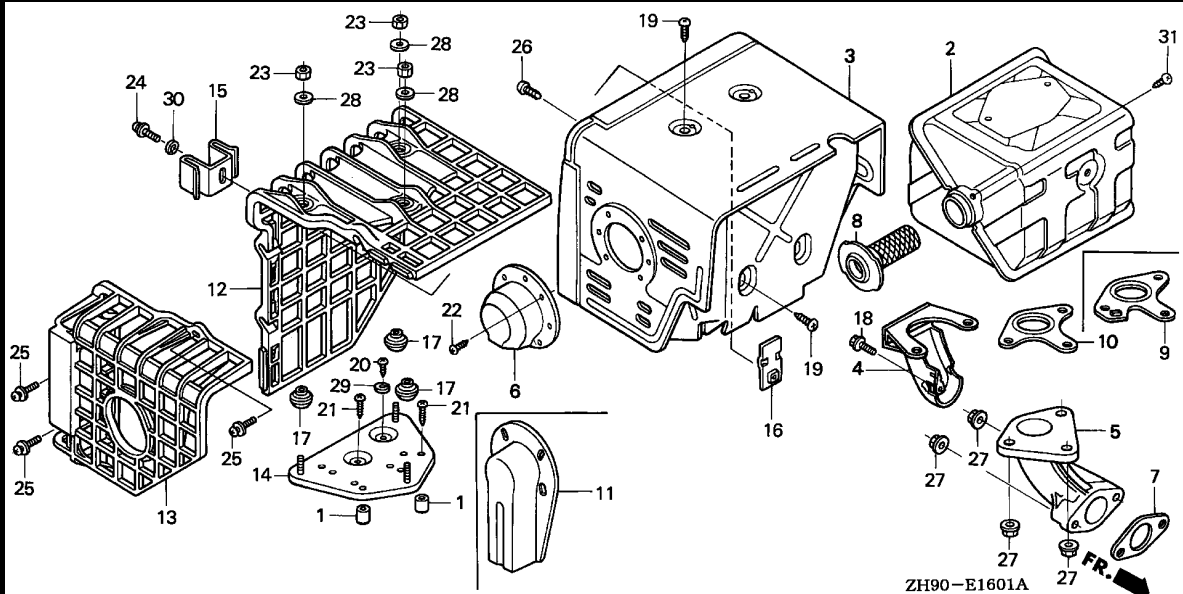

Ref. No.	Part No.	Description	Reqd. QTY			Serial No.	Parts catalogue code
			GX270 (1)	(2)	(3)		
27	94050-08000	NUT, FLANGE, 8MM	2	-	-	VPE5,VPX5	ES1,ES1/A,HX,HX/A,HXQ4,HXQ4/A,HX26,HX26/A,HX8,HX8/A,LTJ,LWD1 LWD1/A,LX,LX/A,LXE,LXE/A,LXE8,LXE8/A,LXQ4,LXQ4/A,LXU,LXU/A,LXZ LX16,PX,PX/A,PXE8,PXE8/A,PXU,PXU/A,PX26,PX26/A,QE,QE/A,QKE3 QKE3/A,QKE4,QME2,QME2/A,QSC,QSC9,QSC9/A,QSE,QSE/A,QSE2,QSE8 QSE8/A,QWA2,QWA4,QWA4/A,QWH2,QWH2/A,QX,QX/A,QXB,QXB/A,QXB6,QXB6/A QXB7,QXB7/A,QXC,QXC4,QXC4/A,QXC6,QXC6/A,QXC9,QXC9/A,QXE,QXE/A QXEB,QXE4,QXE4/A,QXE6,QXE6/A,QXE8,QXE8/A,QXQ4,QXQ4/A,QXU,QXU/A RSC2,RSC2/A,RX,RX/A,RXP,RXP/A,RXQ4,RXQ4/A,RXU,RXU/A,SE,SE/A,SMC4 SMC4/A,SME1,SME1/A,SME6,SME6/A,SWA4,SX,SX/A,SXB,SXB/A,SXB7,SXB7/A SXE,SXE/A,SXEB,SXEB/A,SXE4,SXE4/A,SXE8,SXE8/A,SXQ4,SXQ4/A,SXU SXU/A,SX2,VD16,VEB6,VKB2,VKB2/A,VNG1,VNG1/A,VNT2,VNT2/A,VN17 VN17/A,VSD,VSD/A,VSD7,VSD7/A,VSH7,VX,VX/A,VXB,VXB/A,VXB2,VXB6 VXB7,VXB7/A,VXE,VXEB,VXEB/A,VXE4,VXE4/A,VXE6,VXE6/A,VXE7,VXE7/A VXG,VXP,VXP/A,VXQP,VXQ4,VXQ4/A,VXTB,VXT1,VXT1/A,VXU,VXU/A,VXU1 VXU1/A,VX26
28	94103-05700	WASHER, PLAIN, 5MM	-	(5)	-	HXQ4,HXQ4/A,LXQ4,LXQ4/A,QE,QE/A,QKE3,QKE3/A,QKE4,QME2,QME2/A,QWA4 QWA4/A,QXB,QXB/A,QXB7,QXB7/A,QXC4,QXC4/A,QXE4,QXE4/A,QXQ4,QXQ4/A RXQ4,RXQ4/A,SE,SE/A,SMC4,SMC4/A,SME1,SME1/A,SMC6,SMC6/A,SWA4,SXB SXB/A,SXB7,SXB7/A,SXEB,SXEB/A,SXE4,SXE4/A,SXQ4,SXQ4/A,VD16,VEB6 VNG1,VNG1/A,VN17,VN17/A,VSD,VSD/A,VSD7,VSD7/A,VSH7,VWT4,VWT4/A VXB,VXB/A,VXB7,VXB7/A,VXEB,VXEB/A,VXE4,VXE4/A,VXE6,VXE6/A,VXE7,VXE7/A,VXG VXQP,VXQ4,VXQ4/A,VXTB	

2

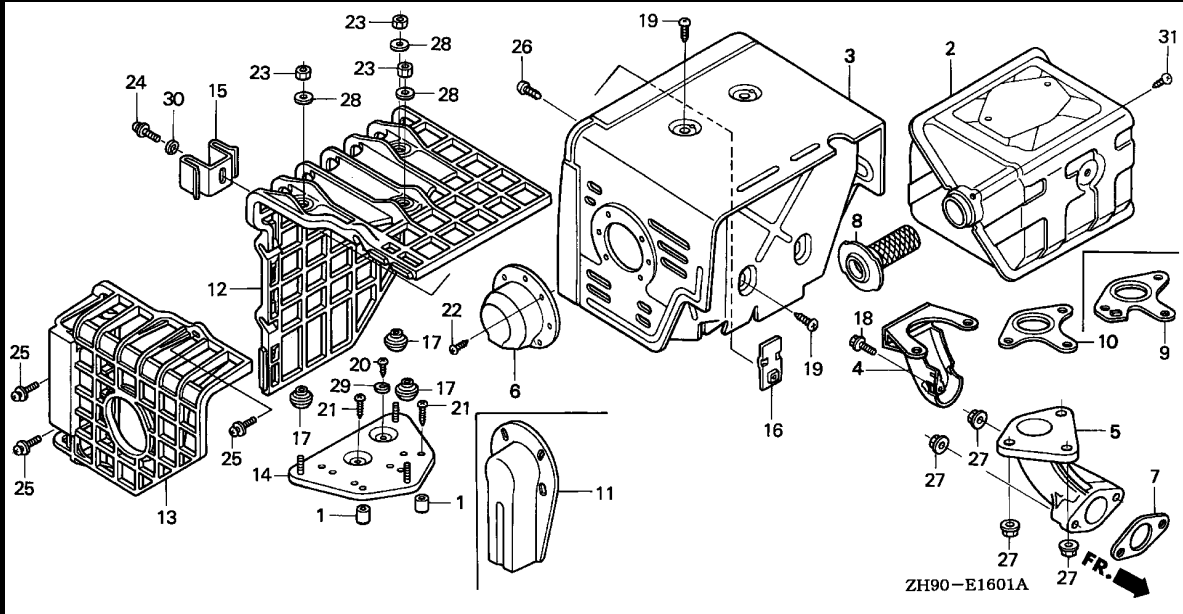

Ref. No.	Part No.	Description	Reqd. QTY			Serial No.	Parts catalogue code
			(1)	(2)	(3)		
29	94111-05000	WASHER, SPRING, 5MM	(1)	-	(1)	-----	HXQ4, HXQ4/A, LXQ4, LXQ4/A, QE, QE/A, QKE3, QKE3/A, QKE4, QME2, QME2/A, QWA4, QWA4/A, QXB, QXB/A, QXB7, QXB7/A, QXC4, QXC4/A, QXE4, QXE4/A, QXQ4, QXQ4/A, RXQ4, RXQ4/A, SE, SE/A, SMC4, SMC4/A, SME1, SME1/A, SME6, SME6/A, SWA4, SXB, SXB/A, SXB7, SXB7/A, SXEB, SXEB/A, SXE4, SXE4/A, SXQ4, SXQ4/A, VD16, VEB6, VNG1, VNG1/A, VN17, VN17/A, VSD, VSD/A, VSD7, VSD7/A, VSH7, VWT4, VWT4/A, VXB, VXB/A, VXB7, VXB7/A, VXEB, VXEB/A, VXE4, VXE4/A, VXE7, VXE7/A, VXG, VXQP, VXQ4, VXQ4/A, VXTB
30	94111-05000	WASHER, SPRING, 5MM	(1)	-	(1)	-----	HXQ4, HXQ4/A, LXQ4, LXQ4/A, QE, QE/A, QKE3, QKE3/A, QKE4, QME2, QME2/A, QWA4, QWA4/A, QXB, QXB/A, QXB7, QXB7/A, QXC4, QXC4/A, QXE4, QXE4/A, QXQ4, QXQ4/A, RXQ4, RXQ4/A, SE, SE/A, SMC4, SMC4/A, SME1, SME1/A, SME6, SME6/A, SWA4, SXB, SXB/A, SXB7, SXB7/A, SXEB, SXEB/A, SXE4, SXE4/A, SXQ4, SXQ4/A, VD16, VEB6, VNG1, VNG1/A, VN17, VN17/A, VSD, VSD/A, VSD7, VSD7/A, VSH7, VWT4, VWT4/A, VXB, VXB/A, VXB7, VXB7/A, VXEB, VXEB/A, VXE4, VXE4/A, VXE7, VXE7/A, VXG, VXQP, VXQ4, VXQ4/A, VXTB
31	90050-ZE1-000	SCREW, TAPPING, 5X8	1	-	-	-----	QXB7, QXB7/A, SXB7, SXB7/A, VSD7, VSD7/A, VSH7, VXB7, VXB7/A, VXE7, VXE7/A, L1, L1/A, QSC, QXC, Q1, Q1/A, R1, R1/A, S1, S1/A, V1, W1, W1/A
	90055-ZE1-000	SCREW, TAPPING, 4X6	1	-	-	-----	QE, QE/A, QXB, QXB/A, QXEB, SE, SE/A, SMC4, SMC4/A, SXB, SXB/A, SXEB, SXEB/A, VD16, VEB6, VKB2, VKB2/A, VNG1, VNG1/A, VNT2, VNT2/A, VSD, VSD/A, VXB, VXB/A, VXB2, VXB6, VXEB, VXEB/A, VXG, VXTB
			(1)	(1)	-	-----	HXQ4, HXQ4/A, HX26, HX26/A, L1, L1/A, QSC, QSC9, QSC9/A, QSE2, QWA2, QWA4, QWA4/A, QWH2, QWH2/A, QXC, QXC4, QXC4/A, QXC6, QXC6/A, QXC9, QXC9/A, Q1, Q1/A, Q2, RSC2, RSC2/A, R1, R1/A, V1, W1, W1/A



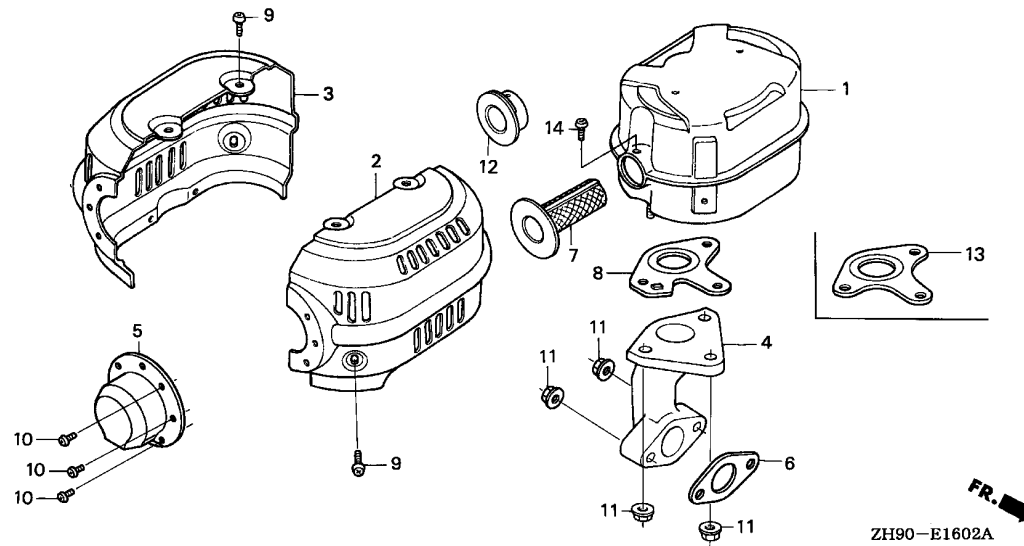

Ref. No.	L.O.N.	(Relative ref. Number) Description	F.R.T.
1	3131C5	MUFFLER, EXHAUST	0.2
2	3131H0	PROTECTOR, EXHAUST MUFFLER :FRONT	0.2
3	3131D3	PROTECTOR, EXHAUST MUFFLER :REAR	0.2
4	3131C9	PIPE, EXHAUST	0.2
6	3131B5	GASKET, EXHAUST PIPE	0.2
7	3131A1	ARRESTER, SPARK .INCLUDES: Spark arrester check (13)	0.2
8	3131B4	GASKET, EXHAUST MUFFLER	0.2

Ref. No.	Part No.	Description	Reqd. QTY			Serial No.	Parts catalogue code
			(1)	(2)	(3)		
1	18310-ZE2-013	MUFFLER COMP.	1	-	-	QAW,QAW/A	
			(1)	-	-	QD,QD/A,RD,RD/A,SD,SD/A	
	18310-ZE2-822	MUFFLER COMP. (SILENT)	-	(1)	-	QD,QD/A,RD,RD/A,SD,SD/A	
2	18320-ZE2-P30	PROTECTOR, R. MUFFLER (STD.)	1	-	-	QAW,QAW/A	
	18320-ZE2-003	PROTECTOR, R. MUFFLER	(1)	-	-	QD,QD/A,RD,RD/A,SD,SD/A	
			-	(1)	-		
	18320-ZE2-821	PROTECTOR, R. MUFFLER (SILENT)	(1)	(1)	-	1075941 L1,QD,Q1,Q2,RD,R1,SD,S1,V1,W1	
	18320-ZE2-P50	(1)	(1)	-	L1/A,QD/A,Q1/A,RD/A,R1/A,SD/A,S1/A,W1/A	
			(1)	(1)	-	1075942 L1,QD,Q1,Q2,RD,R1,SD,S1,V1,W1	
3	18325-ZE2-P30	PROTECTOR, L. MUFFLER (STD.)	1	-	-	QAW,QAW/A	
	18325-ZE2-003	PROTECTOR, L. MUFFLER	(1)	-	-	QD,QD/A,RD,RD/A,SD,SD/A	
			-	(1)	-		
	18325-ZE2-821	PROTECTOR, L. MUFFLER (SILENT)	(1)	(1)	-	1075941 L1,QD,Q1,Q2,RD,R1,SD,S1,V1,W1	
	18325-ZE2-P50	(1)	(1)	-	L1/A,QD/A,Q1/A,RD/A,R1/A,SD/A,S1/A,W1/A	
			(1)	(1)	-	1075942 L1,QD,Q1,Q2,RD,R1,SD,S1,V1,W1	
4	18330-ZE2-000	PIPE, EX.	1	-	-	QAW,QAW/A	
			(1)	-	-	QD,QD/A,RD,RD/A,SD,SD/A	
			-	(1)	-		
5	18331-ZE2-810	CAP, MUFFLER	1	-	-	QAW,QAW/A	
6	18333-ZE3-800	GASKET, EX. PIPE	1	-	-	QAW,QAW/A	
7	18355-ZE2-010	ARRESTER, SPARK	1	-	-	QAW,QAW/A	
			(1)	-	-	QD,QD/A,RD,RD/A,SD,SD/A	
			-	(1)	-		
8	18381-ZE2-820	GASKET, MUFFLER (ARRESTER) ..	(1)	(1)	-	1053817 L1,QD,Q1,Q2,RD,R1,SD,S1,V1,W1	



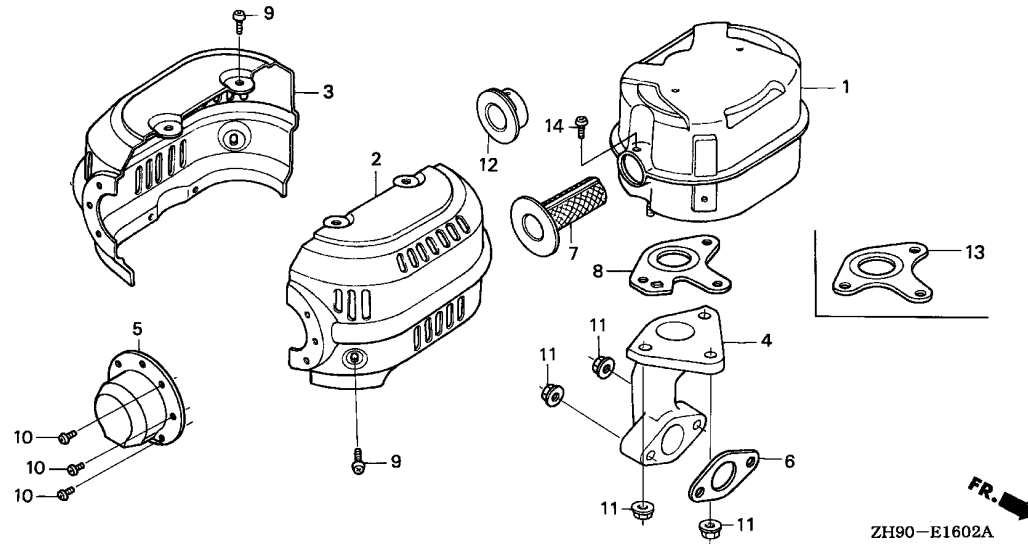

ZH90-E1602A

Ref. No.	Part No.	Description	Reqd. QTY			Serial No.	Parts catalogue code	
			(1)	(2)	(3)			
(8)	18381-ZE2-W10	GASKET, MUFFLER (ARRESTER) ..	1	(1)	-	-----	L1/A,QAW,QAW/A,Q1/A,R1/A,S1/A,W1/A	
			(1)	(1)	-	1053818	-----	L1,QD,Q1,Q2,RD,R1,SD,S1,V1,W1
			(1)	-	-	-----	-----	QD/A,RD/A,SD/A
9	90050-ZE1-000	SCREW, TAPPING, 5X8	6	-	-	-----	-----	QAW,QAW/A
	90050-ZE3-H00	(6)	(6)	-	1075941	-----	L1,QD,Q1,RD,R1,SD,S1,V1,W1
			(6)	(6)	-	-----	-----	L1/A,QD/A,Q1/A,Q2,RD/A,R1/A,SD/A,S1/A,W1/A
10	90055-ZE1-000	SCREW, TAPPING, 4X6	(6)	(6)	-	1075942	-----	L1,QD,Q1,RD,R1,SD,S1,V1,W1
			3	-	-	-----	-----	QAW,QAW/A
11	94050-08000	NUT, FLANGE, 8MM	5	-	-	-----	-----	QAW,QAW/A
			(3)	-	-	-----	-----	QD,QD/A,RD,RD/A,SD,SD/A
			-	(3)	-	-----	-----	-----
12	18336-ZE2-000	FLANGE COMP., BAFFLE	(1)	-	-	-----	-----	QD,QD/A,RD,RD/A,SD,SD/A
			-	(1)	-	-----	-----	-----
13	18381-ZE2-800	GASKET, MUFFLER	(1)	-	-	-----	-----	QD,QD/A,RD,RD/A,SD,SD/A
			-	(1)	-	-----	-----	-----
14	90050-ZE1-000	SCREW, TAPPING, 5X8	1	-	-	-----	-----	QAW,QAW/A
	90055-ZE1-000	SCREW, TAPPING, 4X6	(1)	-	-	-----	-----	QD,QD/A,RD,RD/A,SD,SD/A
			-	(1)	-	-----	-----	-----

E-16-3

MUFFLER(4)

N 1

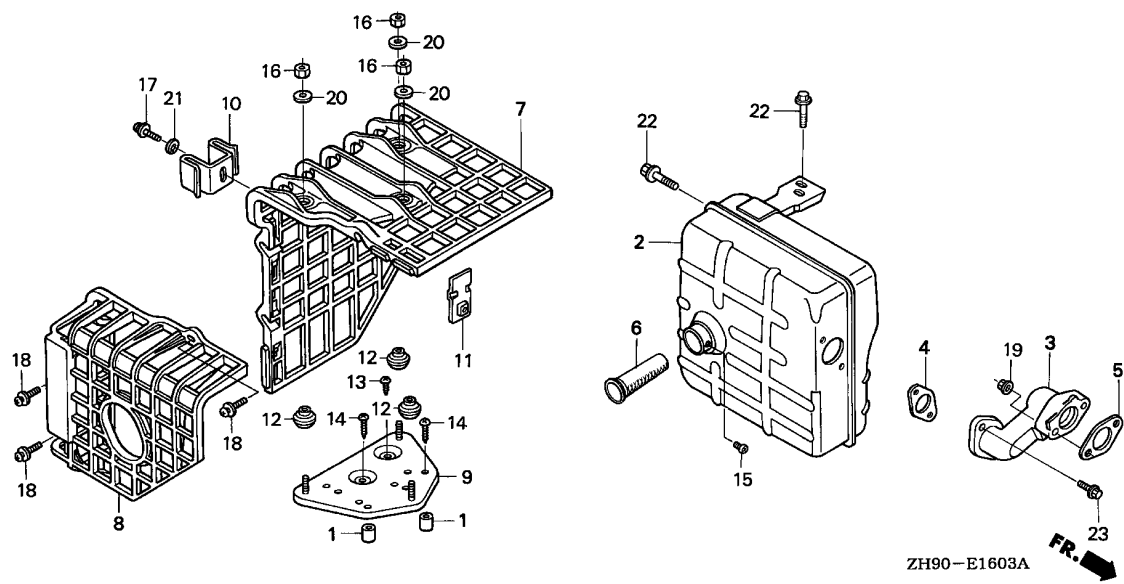

Ref. No.	L.O.N.	(Relative ref. Number) Description	F.R.T.
2	3131C5	MUFFLER, EXHAUST	0.2
3	3131C9	PIPE, EXHAUST	0.2
4		(5)	
	3131B5	GASKET, EXHAUST PIPE	0.2
6	3131A1	ARRESTER, SPARK	0.2
		.INCLUDES: Spark arrester check	
7	3131A7	COVER, EXHAUST MUFFLER	0.1
8	3131K6	COVER, EXHAUST MUFFLER :RIGHT	0.1
9	3131A2	BASE, EXHAUST MUFFLER COVER ..	0.2

Ref. No.	Part No.	Description	Reqd. QTY			Serial No.	Parts catalogue code
			(1)	(2)	(3)		
1	17233-896-701	COLLAR, AIR CLEANER CASE	(2)	-	-	-----	VPE4,VPE4/A,VPE7,VPE7/A,VPX4,VPX4/A,VPX7,VPX7/A,VSD3/A,VS37 VS37/A
2	18310-ZD1-E31	MUFFLER COMP.	(2)	-	-	1106096	----- VSD3
	18310-ZH9-V01	MUFFLER COMP. (SDMO)	1	-	-	1085396	----- VSD3
			1	-	-	-----	VPE4,VPE4/A,VPE7,VPE7/A,VPX4,VPX4/A,VPX7,VPX7/A,VSD3/A,VS37 VS37/A
3	18330-ZE2-700	PIPE, EX.	1	-	-	1085397	----- VSD3
			1	-	-	-----	VPE4,VPE4/A,VPE7,VPE7/A,VPX4,VPX4/A,VPX7,VPX7/A,VSD3,VSD3/A,VS37 VS37/A
4	18333-ZB4-800	GASKET, EX. PIPE	1	-	-	-----	VPE4,VPE4/A,VPE7,VPE7/A,VPX4,VPX4/A,VPX7,VPX7/A,VSD3,VSD3/A,VS37 VS37/A
5	18333-ZE3-800	GASKET, EX. PIPE	1	-	-	-----	VPE4,VPE4/A,VPE7,VPE7/A,VPX4,VPX4/A,VPX7,VPX7/A,VSD3,VSD3/A,VS37 VS37/A
6	18355-ZB4-630	ARRESTER, SPARK	1	-	-	-----	VPE4,VPE4/A,VPE7,VPE7/A,VPX4,VPX4/A,VPX7,VPX7/A,VSD3,VSD3/A,VS37 VS37/A
7	18433-ZF6-W40	COVER COMP., MUFFLER	(1)	-	-	-----	VPE4,VPE4/A,VPE7,VPE7/A,VPX4,VPX4/A,VPX7,VPX7/A,VSD3/A,VS37 VS37/A
			(1)	-	-	1106096	----- VSD3
8	18434-ZF6-W40	COVER COMP., MUFFLER RR.	(1)	-	-	-----	VPE4,VPE4/A,VPE7,VPE7/A,VPX4,VPX4/A,VPX7,VPX7/A,VSD3/A,VS37 VS37/A
			(1)	-	-	1106096	----- VSD3
9	18436-ZH8-W40	BASE COMP., MUFFLER COVER ...	(1)	-	-	-----	VPE4,VPE4/A,VPE7,VPE7/A,VPX4,VPX4/A,VPX7,VPX7/A,VSD3/A,VS37 VS37/A
			(1)	-	-	1106096	----- VSD3
10	18437-ZF6-W40	STAY, MUFFLER COVER	(1)	-	-	-----	VPE4,VPE4/A,VPE7,VPE7/A,VPX4,VPX4/A,VPX7,VPX7/A,VSD3/A,VS37 VS37/A
			(1)	-	-	1106096	----- VSD3

2

E-16-3

MUFFLER(4)

N 2

Ref. No.	Part No.	Description	Reqd. QTY			Serial No.	Parts catalogue code	
			(1)	(2)	(3)			
11	18438-ZF6-W40	PLATE, SET	(1)	-	-	-----	VPE4,VPE4/A,VPE7,VPE7/A,VPX4,VPX4/A,VPX7,VPX7/A,VSD3/A,VS37 VS37/A	
12	18466-ZH8-W40	SPACER, MUFFLER COVER	(1)	-	-	1106096	-----	VSD3
13	90050-ZE1-000	SCREW, TAPPING, 5X8	(3)	-	-	1106096	-----	VPE4,VPE4/A,VPE7,VPE7/A,VPX4,VPX4/A,VPX7,VPX7/A,VSD3/A,VS37 VS37/A
14	90050-ZH8-W40	SCREW, TAPPING, 5X25	(1)	-	-	1106096	-----	VSD3
15	90002-ZE2-U91	SCREW, TAPPING, 4X8	(2)	-	-	1106096	-----	VPE4,VPE4/A,VPE7,VPE7/A,VPX4,VPX4/A,VPX7,VPX7/A,VSD3/A,VS37 VS37/A
16	90302-KF9-900	NUT, HEX., 5MM	(3)	-	-	-----	-----	VPE4,VPE4/A,VPE7,VPE7/A,VPX4,VPX4/A,VPX7,VPX7/A,VSD3/A,VS37 VS37/A
17	93891-05012-00	SCREW-WASHER, 5X12	(1)	-	-	1106096	-----	VSD3
18	93891-06020-07	SCREW-WASHER, 6X20	(1)	-	-	1106096	-----	VPE4,VPE4/A,VPE7,VPE7/A,VPX4,VPX4/A,VPX7,VPX7/A,VSD3/A,VS37 VS37/A
19	94050-08000	NUT, FLANGE, 8MM	(3)	-	-	1106096	-----	VSD3
20	94103-05700	WASHER, PLAIN, 5MM	2	-	-	-----	-----	VPE4,VPE4/A,VPE7,VPE7/A,VPX4,VPX4/A,VPX7,VPX7/A,VSD3,VSD3/A,VS37 VS37/A
21	94111-05000	WASHER, SPRING, 5MM	(3)	-	-	-----	-----	VPE4,VPE4/A,VPE7,VPE7/A,VPX4,VPX4/A,VPX7,VPX7/A,VSD3/A,VS37 VS37/A
22	95701-08016-00	BOLT, FLANGE, 8X16	(1)	-	-	1106096	-----	VSD3
	95701-08016-08	2	-	-	-----	-----	VSD3
23	95701-08020-00	BOLT, FLANGE, 8X20	2	-	-	-----	-----	VPE4,VPE4/A,VPE7,VPE7/A,VPX4,VPX4/A,VPX7,VPX7/A,VSD3/A,VS37,VS37/A
	95701-08020-08	2	-	-	-----	-----	VSD3,VSD3/A,VS37,VS37/A

2

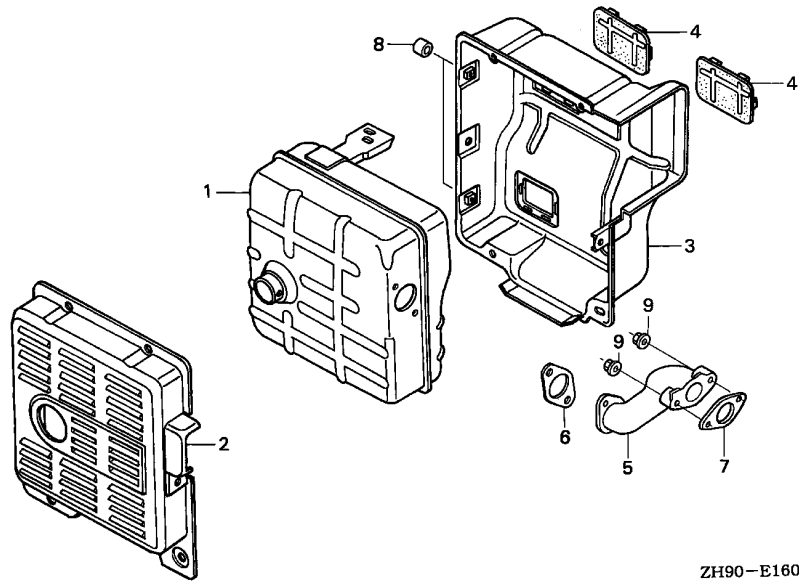

Ref. No.	L.O.N.	(Relative ref. Number) Description	F.R.T.
1	3131C5	MUFFLER, EXHAUST	0.2
2	3131D9	PROTECTOR, EXHAUST MUFFLER : OUTER	0.1
3	3131D8	PROTECTOR, EXHAUST MUFFLER : INNER	0.3
4	3131G6	SEAL, MUFFLER PROTECTOR	0.3
5	3131C9	PIPE, EXHAUST	0.2
6	3131B5	GASKET, EXHAUST PIPE	0.2

2

Ref. No.	Part No.	Description	Reqd. QTY			Serial No.	Parts catalogue code
			(1)	(2)	(3)		
			GX270				
1	18310-ZD1-E31	MUFFLER COMP.	1	-	-	-----	ES3,ES3/A,VMT,VMT/A
	18310-ZE2-V60	MUFFLER COMP. (TSURUMI)	1	-	-	-----	VKE4,VKX4,VS3
2	18320-ZB4-000	PROTECTOR, MUFFLER OUTER	1	-	-	-----	ES3,ES3/A,VKE4,VKX4,VMT,VMT/A,VS3
3	18325-ZB4-000	PROTECTOR, MUFFLER INNER	1	-	-	-----	ES3,ES3/A,VKE4,VKX4,VMT,VMT/A,VS3
4	18329-ZB4-000	SEAL, MUFFLER PROTECTOR	2	-	-	-----	ES3,ES3/A,VKE4,VKX4,VMT,VMT/A,VS3
5	18330-ZE2-700	PIPE, EX.	1	-	-	-----	VKE4,VKX4,VMT,VMT/A
	18330-ZH9-D40	1	-	-	-----	ES3,ES3/A,VS3
6	18333-ZB4-800	GASKET, EX. PIPE	1	-	-	-----	ES3,ES3/A,VKE4,VKX4,VMT,VMT/A,VS3
7	18333-ZE3-800	GASKET, EX. PIPE	1	-	-	-----	ES3,ES3/A,VKE4,VKX4,VMT,VMT/A,VS3
8	91552-ZT1-000	COLLAR, 6.9X9	2	-	-	-----	ES3,ES3/A
9	94050-08000	NUT, FLANGE, 8MM	2	-	-	-----	ES3,ES3/A,VKE4,VKX4,VMT,VMT/A,VS3

E-16-5

MUFFLER(6)

N 4

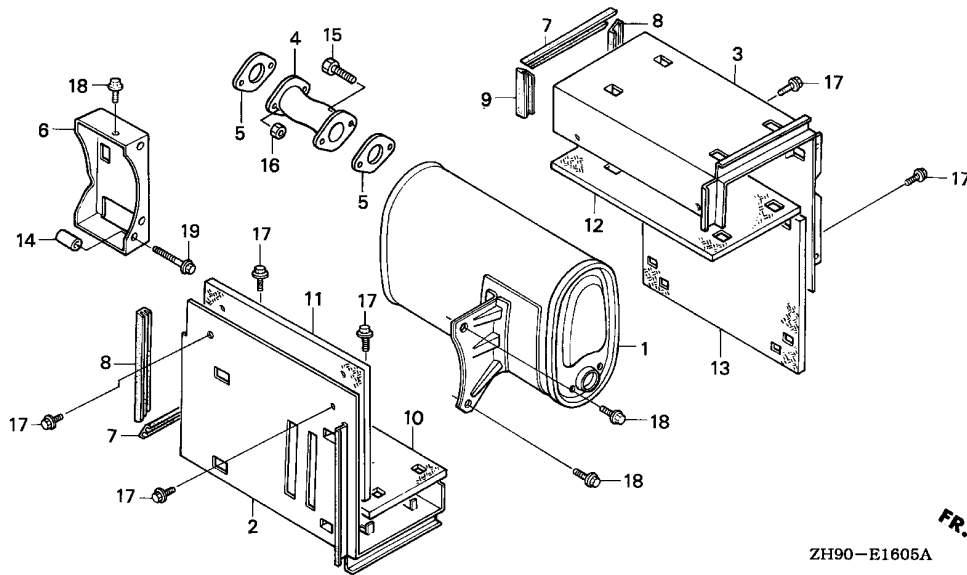

Ref. No.	L.O.N.	(Relative ref. Number) Description	F.R.T.
1	3131F7	MUFFLER, EXHAUST(A)	0.3
2	3131L3	DUCT, MUFFLER :RIGHT	0.2
3	3131L2	DUCT, MUFFLER :LEFT	0.2
4	3131G1	PIPE, EXHAUST(A)	0.3
5	3131H9	GASKET, EXHAUST PIPE(A)	0.3
10	3131L5	INSULATOR A, MUFFLER DUCT :RIGHT	0.2
11	3131L7	INSULATOR B, MUFFLER DUCT :RIGHT	0.2
12	3131L4	INSULATOR A, MUFFLER DUCT :LEFT	0.2
13	3131L6	INSULATOR B, MUFFLER DUCT :LEFT	0.2

Ref. No.	Part No.	Description	Reqd. QTY			Serial No.	Parts catalogue code
			(1)	(2)	(3)		
1	18310-ZB7-003	MUFFLER COMP.	1	-	-	ESS,ESS/A,SJP	
2	18321-ZB7-000	DUCT, LOWER MUFFLER	1	-	-	ESS,ESS/A	
3	18325-ZB7-000	DUCT, UPPER MUFFLER	1	-	-	ESS,ESS/A	
4	18330-ZB7-003	PIPE COMP., EX.	1	-	-	ESS,ESS/A,SJP	
5	18333-ZB7-800	GASKET, EX. PIPE	2	-	-	ESS,ESS/A,SJP	
6	18338-ZB7-000	STAY COMP., MUFFLER	1	-	-	ESS,ESS/A	
7	18412-ZB7-000	SEAL, MUFFLER DUCT (A)	2	-	-	ESS,ESS/A	
8	18413-ZB7-000	SEAL, MUFFLER DUCT (B)	2	-	-	ESS,ESS/A	
9	18414-ZB7-000	SEAL, MUFFLER DUCT (C)	2	-	-	ESS,ESS/A	
10	64181-ZB7-000	INSULATOR A, LOWER MUFFLER DUCT	1	-	-	ESS,ESS/A	
11	64182-ZB7-000	INSULATOR B, LOWER MUFFLER DUCT	1	-	-	ESS,ESS/A	
12	64185-ZB7-000	INSULATOR A, UPPER MUFFLER DUCT	1	-	-	ESS,ESS/A	
13	64186-ZB7-000	INSULATOR B, UPPER MUFFLER DUCT	1	-	-	ESS,ESS/A	
14	91551-ZB7-000	COLLAR, MUFFLER STAY	1	-	-	ESS,ESS/A	
15	92101-08028-0A	BOLT, HEX., 8X28	2	-	-	ESS,ESS/A	
16	94001-08000-0S	NUT, HEX., 8MM	2	-	-	ESS,ESS/A	
17	95701-06012-00	BOLT, FLANGE, 6X12	8	-	-	ESS,ESS/A	
18	95701-08016-00	BOLT, FLANGE, 8X16	3	-	-	ESS,ESS/A	
19	95701-08040-00	BOLT, FLANGE, 8X40	1	-	-	ESS,ESS/A	

2

E-17

FUEL TANK(1)

N 5

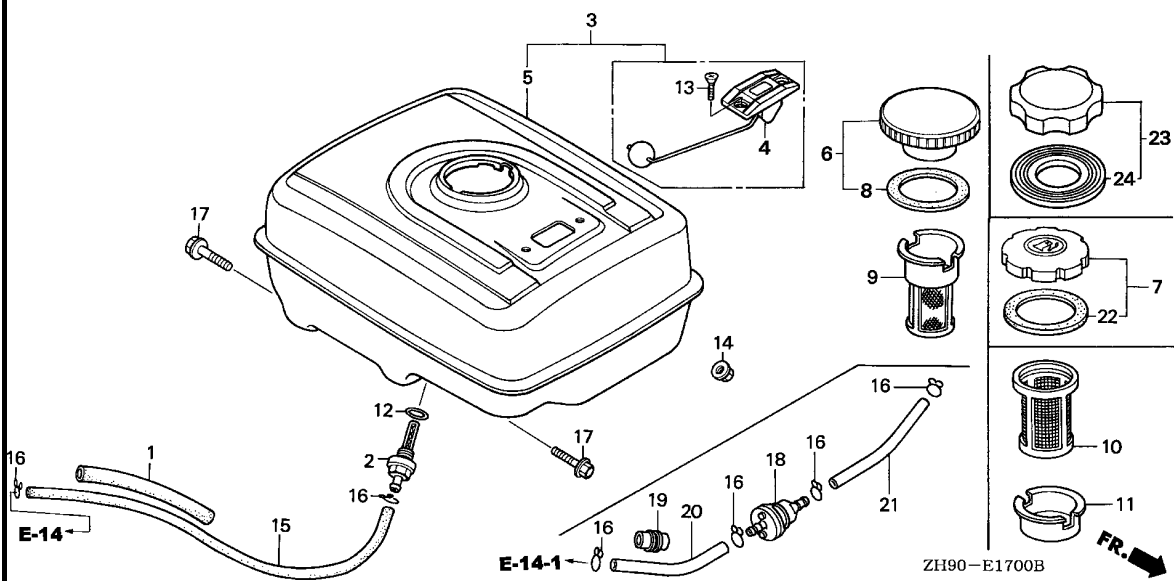

Ref. No.	L.O.N.	(Relative ref. Number) Description	F.R.T.
2	3101H6	(12) JOINT, FUEL STRAINER	0.2
3	3101H7	(5) TANK, FUEL	0.2
4	6171A1	METER/GAUGE UNIT, FUEL	0.1
9	3101A6	(10) FILTER, FUEL	0.1
15	3101F1	TUBE, FUEL TANK	0.2
18	3101H8	STRAINER, FUEL	0.1
20	3101G0	TUBE, FUEL STRAINER	0.1
21	3101F6	TUBE, FUEL	0.1

2

Ref. No.	Part No.	Description	Reqd. QTY			Serial No.	Parts catalogue code
			(1)	(2)	(3)		
1	16854-ZE1-000	RUBBER, SUPPORTER (107MM) ...	1	-	-	HA,LJ,PA,RA,SJ,SK,VA	
			1	-	-	1012864	HH,HX,LH,LHE,LW,LX,LXZ,PX,QA,QAE,QD,QE,QH,QHC,QHE,QX,QXB,QXC,QXE,QXEB,RD,RH,RHE,RX,SD,SE,SH,SHE,SHEZ,SW,SWE,SX,SXB,SXE,SXEB,VH,VX,VXB,VXE,VXEB
			-	(1)	-	1044603	L1,Q1,R1,S1,V1,W1

Ref. No.	Part No.	Description	Reqd. QTY			Serial No.	Parts catalogue code		
			(1)	(2)	(3)				
(1)	16854-ZH8-000	RUBBER, SUPPORTER (107MM) ...	1	(1)	-	-----	ES1, ES1/A, HAQ, HA2, HA2/A, HEA, HEA2, HEA2/A, HEA8, HEA8/A, HX/A, HXQ4, HXQ4/A, HX26, HX26/A, HX8, HX8/A, LH/A, LHB1, LHB3, LHB5, LHE/A, LHQ4, LJ/A, LJC, LJC/A, LJG, LJG/A, LSS, LT, LT/A, LTJ, LW/A, LWD, LWD1, LWD1/A, LX/A, LXE, LXE/A, LX8, LX8/A, LXQ4, LXQ4/A, LXU, LXU/A, LX16, LX16/A, PAE2, PAE2/A, PA2, PA2/A, PX/A, PXE8, PXE8/A, PXU, PXU/A, PX26, PX26/A, QAB1, QAB3, QAB3/A, QAE2, QAE2/A, QAE6, QAE6/A, QAG, QAG/A, QAG2, QAG2/A, QAG, QAG4/A, QAR2, QAR2/A, QAW, QAW/A, QA2, QA2/A, QD/A, QE/A, QH/A, QHB5, QHE4, QHE4/A, QHP1, QHP1/A, QHQ4, QHQ4/A, QHR, QHR/A, QHR4, QHR4/A, QHZ, QHZ/A, QH26, QH26/A, QKE3, QKE3/A, QKE4, QL2, QME2, QME2/A, QMH, QMH/A, QP, QP/A, QSC, QSC9, QSC9/A, QSE, QSE/A, QSE2, QSE8, QSE8/A, QT, QT/A, QWA2, QWA4, QWA4/A, QWH2, QWH2/A, QX/A, QXB/A, QXB6, QXB6/A, QXB7, QXB7/A, QXC4, QXC4/A, QXC6, QXC6/A, QXC9, QXC9/A, QXE/A, QXE4, QXE4/A, QXE6, QXE6/A, QXE8, QXE8/A, QXQ4, QXQ4/A, QXU, QXU/A, QX26, QX26/A, Q1/A, Q2, RA2, RA2/A, RD/A, RHE4, RHE4/A, RHQ4, RHQ4/A, RH26, RH26/A, RSS, RSS/A, RX/A, RXQ4, RXQ4/A, RXU, RXU/A, R1/A, SD/A, SE/A, SH/A, SHQ4, SHQ4/A, SJ/A, SJG, SJG/A, SMC4, SMC4/A, SMD, SME1, SME1/A, SME6, SME6/A, SMX2, SN, SN/A, SWA4, SWC4, SWC4/A, SX/A, SXB/A, SXB7, SXB7/A, SXE/A, SXEB/A, SXE4, SXE4/A, SXE8, SXE8/A, SXQ4, SXQ4/A, SXU, SXU/A, SX2, S1/A, VAG2, VAG2/A, VAW1, VA2, VA2/A, VDE, VDE2, VDE2/A, VD16, VEB6, VEB6/A, VKB2, VKB2/A, VMA4, VME2, VME2/A, VME4, VMS2, VMX2, VM2, VM2/A, VNG1, VNG1/A, VNT2, VNT2/A, VN17, VN17/A, VSD, VSD/A, VSD3, VSD3/A, VSD7, VSD7/A, VS37, VS37/A, VWN2, VWN2/A, VW12, VW12/A, VW22, VX/A, VXB/A, VXB2, VXB6, VXB7, VXB7/A, VXEB/A, VXE4, VXE4/A, VXE6, VXE6/A, VXE7, VXE7/A, VXG, VXQ4, VXQ4/A, VXTB, VXU, VXU/A, VXU1, VXU1/A, VX26, WMA4, WMT8, WMT8/A, WXE8, WXE8/A, W1/A, HH, HX, LH, LHE, LW, LX, LXZ, PX, QA, QAE, QD, QE, QH, QHC, QHE, QX, QXB, QXC, QXE, QXEB, RD, RH, RHE, RX, SD, SE, SH, SHE, SHEZ, SW, SWE, SX, SXB, SXE, SXEB, VH, VXB, VXE, VXE8		
			1	-	-	1012865	-----	L1, Q1, R1, S1, V1, W1	
2	16955-ZE1-000	JOINT, FUEL TANK	1	(1)	-	-----	1044604	-----	ES1, ES1/A, HA, HAQ, HA2, HA2/A, HEA, HEA2, HEA2/A, HEA8, HEA8/A, HH, HX, HX/A, HXQ4, HXQ4/A, HX26, HX26/A, HX8, HX8/A, LH, LH/A, LHB1, LHB3, LHB5, LHE, LHE/A, LHQ4, LJ, LJ/A, LJC, LJC/A, LJG, LJG/A, LSS, LT, LT/A, LTJ, LW, LW/A, LWD, LWD1, LWD1/A, LX, LX/A, LXE, LXE/A, LXE8, LXE8/A, LXQ4, LXQ4/A, LXU, LXU/A, LXZ, LX16, PA, PAE2, PAE2/A, PA2, PA2/A, PX, PX/A, PXE8, PXE8/A, PXU, PXU/A, PX26, PX26/A, QA, QAB1, QAB3, QAB3/A, QAE, QAE2, QAE2/A, QAE6, QAE6/A, QAG, QAG/A, QAG2, QAG2/A, QAG, QAG4/A, QAR2, QAR2/A, QAW, QAW/A, QA2, QA2/A, QD, QD/A, QE, QE/A, QH, QH/A, QHB5, QHC, QHE, QHE4, QHE4/A, QHP1, QHP1/A, QHQ4, QHQ4/A, QHR, QHR/A, QHR4, QHR4/A, QHZ, QHZ/A, QH26, QH26/A, QKE3, QKE3/A, QKE4, QL2, QME2, QME2/A, QMH, QMH/A, QP, QP/A, QSC, QSC9, QSC9/A, QSE, QSE/A, QSE2, QSE8, QSE8/A, QT, QT/A, QWA2, QWA4, QWA4/A, QWH2, QWH2/A, QX, QX/A, QXB, QXB/A, QXB6, QXB6/A, QXB7, QXB7/A, QXC, QXC4, QXC4/A, QXC6, QXC6/A, QXC9, QXC9/A, QXE, QXE/A, QXEB, QXE4, QXE4/A, QXE6, QXE6/A, QXE8, QXE8/A, QXQ4, QXQ4/A, QXU, QXU/A, QX26, QX26/A, RA, RA2, RA2/A, RD, RD/A, RH, RHE, RHE4, RHE4/A, RHQ4, RHQ4/A, RH26, RH26/A, RSS, RSS/A, RX, RX/A, RXQ4, RXQ4/A, RXU, RXU/A, SD, SD/A, SE, SE/A, SH, SH/A, SHE, SHEZ, SHQ4, SHQ4/A, SJ, SJ/A, SJG, SJG/A, SK, SMC4, SMC4/A, SMD, SME1, SME1/A, SME6, SME6/A, SMX2, SN, SN/A, SW, SWA4, SWC4, SWC4/A, SWE, SX, SX/A, SXB, SXB/A, SXB7, SXB7/A, SXE, SXE/A, SXEB, SXEB/A, SXE4, SXE4/A, SXE8, SXE8/A, SXQ4, SXQ4/A, SXU, SXU/A, SX2, VA, VA2, VA2/A, VD16, VEB6, VH, VMA4, VME2, VME2/A, VME4, VM2, VM2/A, VSD, VSD/A, VSD7, VSD7/A, VW22, VX, VX/A, VXB, VXB/A, VXB2, VXB6, VXB7, VXB7/A, VXE, VXE8, VXE8/A, VXE4, VXE4/A, VXE6, VXE6/A, VXE7, VXE7/A, VXG, VXQ4, VXQ4/A, VXTB, VXU, VXU/A, VXU1, VXU1/A, VX26, WMA4, WMT8
			-	(1)	-	-----			WMT8/A, WXE8, WXE8/A
3	17500-ZE2-811ZA	TANK ASSY., FUEL (GAUGE)		(1)	-	-----			LJG, LSS, LTJ, LWD, LWD1, L1, QKE3, QSC, QSC9, Q1, Q2, R1, SJG, S1, VXG, V1, W1
		NH31.....MCKINLEY WHITE	1	(1)	-	-----			LJG/A, LWD1/A, L1/A, QKE3/A, QKE4, QSC9/A, Q1/A, R1/A, SJG/A, S1/A, W1/A
			1	(1)	-	2205487	2399494		LJG/A, LWD1/A, L1/A, QKE3/A, QKE4, QSC9/A, Q1/A, R1/A, SJG/A, S1/A, W1/A
	17500-ZE2-812ZA	*NH31*.....MCKINLEY WHITE	1	(1)	-	2205488	2399495		LJG/A, LWD1/A, L1/A, QKE3/A, QKE4, QSC9/A, Q1/A, R1/A, SJG/A, S1/A, W1/A
	17500-ZE2-813ZA	*NH31*.....MCKINLEY WHITE	1	(1)	-	2399495	-----		LJG/A, LWD1/A, L1/A, QKE3/A, QKE4, QSC9/A, Q1/A, R1/A, SJG/A, S1/A, W1/A



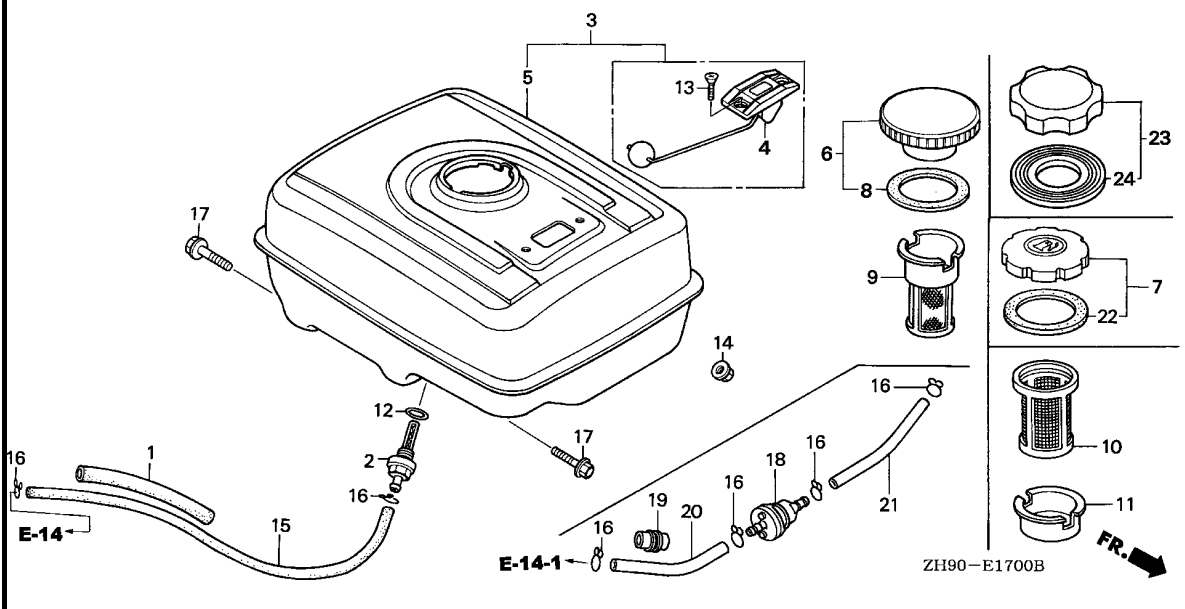

Ref. No.	Part No.	Description	Reqd. QTY			Serial No.	Parts catalogue code	
			(1)	(2)	(3)			
4	17505-ZE2-013	GAUGE ASSY., FUEL	1	-	-	-----	LJG,LJG/A,LSS,LTJ,LWD,LWD1,LWD1/A,QKE3,QKE3/A,QKE4,QSC,QSC9 QSC9/A,SJG,SJG/A,VXG	
5	17510-ZE2-010ZA	TANK COMP., FUEL *NH31*.....MCKINLEY WHITE	1	(1)	-	-----	HA,HA2,HEA,HEA2,HEA8,HH,HX,HXQ4,HX26,HX8,LH,LHB1,LHB3,LHE,LHQ4,LJ LJC,LT,LW,LX,LXE,LXE8,LXQ4,LXU,LXZ,LX16,L1,PA,PAE2,PA2,PX,PXE8 PXU,PX26,QA,QAB1,QAB3,QA2,QA2/A,QA2/A,QAE2,QA2/A,QAE6,QA2/A,QAG,QAG2,QAQ4,QAR2,QAW,QA2,QD QE,QH,QHC,QHE,QHE4,QHP1,QHQ4,QHR,QHR4,QHZ,QH26,QME2,QMH,QP,QSE QSE8,QT,QX,QXB,QXB6,QXB7,QXC,QXC4,QXC6,QXC9,QXE,QXE8,QXE4,QXE6 QXE8,QXQ4,QXU,QX26,Q1,Q2,RA,RA2,RD,RH,RHE,RHE4,RHQ4,RH26,RX,RXQ4 RXU,R1,SD,SE,SH,SHE,SHEZ,SHQ4,SJ,SK,SMC4,SMD,SME1,SME6,SN,SW,SWC4 SWE,SX,SXB,SXB7,SXE,SXE8,SXE4,SXE8,SXQ4,SXU,SX2,S1,VA,VA2,VD16 VEB6,VH,VME2,VM2,VSD,VSD7,VX,VXB,VXB2,VXB6,VXB7,VXE,VXE8,VXE4 VXE6,VXE7,VXQ4,VXTB,VXU,VXU1,VX26,V1,WMT8,WXE8,W1	
			1	(1)	-	2205579	ES1/A,HA2/A,HEA2/A,HEA8/A,HA/A,HXQ4/A,HX26/A,HX8/A,LH/A,LHB5 LHE/A,LJ/A,LJC/A,LT/A,LW/A,LX/A,LXE/A,LXE8/A,LXQ4/A,LXU/A,L1/A PAE2/A,PA2/A,PX/A,PXE8/A,PXU/A,PX26/A,QAB3/A,QA2/A,QA2/A,QAG/A QAQ2/A,QAQ4/A,QAR2/A,QAW/A,QA2/A,QD/A,QE/A,QH/A,QHB5,QHE4/A QHP1/A,QHQ4/A,QHR/A,QHR4/A,QHZ/A,QH26/A,QME2/A,QMH/A,QP/A,QSE/A QSE2,QSE8/A,QT/A,QWA4/A,QX/A,QXB/A,QXB6/A,QXB7/A,QXC4/A,QXC6/A QXC9/A,QXE/A,QXE4/A,QXE6/A,QXE8/A,QXQ4/A,QXU/A,QX26/A,Q1/A,RA2/A RD/A,RHE4/A,RHQ4/A,RH26/A,RX/A,RXQ4/A,RXU/A,R1/A,SD/A,SE/A,SH/A SHQ4/A,SJ/A,SMC4/A,SME1/A,SME6/A,SN/A,SWC4/A,SX/A,SXB/A,SXB7/A SXE/A,SXE8/A,SXE4/A,SXE8/A,SXQ4/A,SXU/A,S1/A,VA2/A,VME2/A,VM2/A VSD/A,VSD7/A,VX/A,VXB/A,VXB7/A,VXE8/A,VXE4/A,VXE6/A,VXE7/A,VXQ4/A VXU/A,VXU1/A,WMT8/A,WXE8/A,W1/A	
			1	-	-	1061100	-----	HAQ,QAQ

2

Ref. No.	Part No.	Description	Reqd. QTY			Serial No.	Parts catalogue code
			(1)	(2)	(3)		
(5)	17510-ZE2-010ZB	TANK COMP., FUEL					
		R8.....BRIGHT RED	1	-	-	-----	ES1
			1	-	-	-----	2096864 ES1/A
	17510-ZE2-010ZD	*NH1*.....BLACK	1	-	-	-----	HAQ,HA2,PA2,QAE2,QAQ,QAQ4,QAR2,QA2,QL2,QWA2,QWA4,QWH2,QXC9,RA2
			1	-	-	1041914	SWC4,VA2,VME2,VM2,VXE7
			1	-	-	-----	HA,QA
			1	-	-	2205579	HA2/A,PA2/A,PX/A,PXU/A,QAE2/A,QAQ4/A,QAR2/A,QA2/A,QWA4/A,QWH2/A
	17510-ZE2-010ZE	*NH105*...MAT BLACK (#15-#20)	1	-	-	-----	QXB/A,QXC9/A,RA2/A,SWC4/A,VA2/A,VME2/A,VM2/A,VXE4/A,VXE7/A,VXU/A
			1	-	-	1041914	VME2,VM2,VW22
			1	-	-	-----	VA
			1	-	-	2205579	VME2/A,VM2/A
	17510-ZE2-010ZG	*T77*.....SEC WINE RED	1	-	-	-----	ES1
			1	-	-	-----	ES1/A
			1	-	-	-----	RSS,RSS/A
	17510-ZE3-010ZA	*NH31*.....MCKINLEY WHITE	1	-	-	-----	ES1/A
	17510-ZE2-010ZH	*R280*.....POWER RED	1	-	-	2096865	2205579
	17510-ZE2-020ZA	*NH31*.....MCKINLEY WHITE	1	(1)	-	2205580	-----
							ES1/A,HA2/A,HEA2/A,HEA8/A,HX/A,HXQ4/A,HX26/A,HX8/A,LH/A,LHB5
							LHE/A,LJ/A,LJC/A,LT/A,LW/A,LX/A,LXE/A,LXE8/A,LXQ4/A,LXU/A,L1/A
							PAE2/A,PA2/A,PX/A,PXE8/A,PXU/A,PX26/A,QAB3/A,QAE2/A,QAE6/A,QAG/A
							QAG2/A,QAQ4/A,QAR2/A,QAW/A,QA2/A,QD/A,QE/A,QH/A,QHB5,QHE4/A
							QHP1/A,QHQ4/A,QHR/A,QHR4/A,QHZ/A,QH26/A,QME2/A,QMH/A,QP/A,QSE/A
							QSE2,QSE8/A,QT/A,QWA4/A,QX/A,QXB/A,QXB6/A,QXB7/A,QXC4/A,QXC6/A
							QXC9/A,QXE/A,QXE4/A,QXE6/A,QXE8/A,QXQ4/A,QXU/A,QX26/A,Q1/A,RA2/A
							RD/A,RHE4/A,RHQ4/A,RH26/A,RX/A,RXQ4/A,RXU/A,R1/A,SD/A,SE/A,SH/A
							SHQ4/A,SJ/A,SMC4/A,SME1/A,SME6/A,SN/A,SWC4/A,SX/A,SXB/A,SXB7/A
							SXE/A,SXEB/A,SXE4/A,SXE8/A,SXQ4/A,SXU/A,S1/A,VA2/A,VME2/A,VM2/A
							VSD/A,VSD7/A,VX/A,VXB/A,VXB7/A,VXEB/A,VXE4/A,VXE6/A,VXE7/A,VXQ4/A
							VXU/A,VXU1/A,WMT8/A,WXE8/A,W1/A
			1	-	-	-----	SWA4,WMA4
	17510-ZE2-020ZD	*NH1*.....BLACK	1	-	-	-----	SMX2,VMA4,VME4
			1	-	-	2205580	-----
							HA2/A,PA2/A,PX/A,PXU/A,QAE2/A,QAQ4/A,QAR2/A,QA2/A,QWA4/A,QWH2/A
							QXB/A,QXC9/A,RA2/A,SWC4/A,VA2/A,VME2/A,VM2/A,VXE4/A,VXE7/A,VXU/A
	17510-ZE2-020ZE	*NH105*...MAT BLACK (#15-#20)	1	-	-	2205580	-----
	17510-ZE2-020ZG	*T77*.....SEC WINE RED	1	-	-	2205580	-----
	17510-ZE2-020ZH	*R280*.....POWER RED	1	-	-	2205580	-----
							ES1/A
6	17620-ZE2-W00	CAP COMP., FUEL FILLER (CHROME PLATED)	1	(1)	-	-----	1090815 HA,HAQ,HA2,HEA,HH,HX,LH,LHE,LJ,LTJ,LW,LWD,LX,LXZ,L1,PA,PA2,PX,QA
							QAE,QAE2,QAQ,QA2,QD,QE,QH,QHC,QHE,QP,QSC,QX,QXB,QXC,QXE,QXEB,Q1
							Q2,RA,RA2,RD,RH,RHE,RX,R1,SD,SE,SH,SHE,SHEZ,SJ,SK,SN,SW,SWE,SX
							SXB,SXE,SXEB,S1,VA,VA2,VH,VSD,VX,VXB,VXE,VXEB,VXU,V1,W1
			1	-	-	-----	LHB1,LHB3,LT,QAB1,QAB3,QHZ,QT
			1	-	-	-----	2118570 LT/A,QAB3/A,QHZ/A,QT/A
7	17620-ZH7-013	CAP COMP., FUEL FILLER	1	(1)	-	1090816	1227142 HA,HAQ,HA2,HEA,HH,HX,LH,LHE,LJ,LTJ,LW,LWD,LX,LXZ,L1,PA,PA2,PX,QA
							QAE,QAE2,QAQ,QA2,QD,QE,QH,QHC,QHE,QP,QSC,QX,QXB,QXC,QXE,QXEB,Q1
							Q2,RA,RA2,RD,RH,RHE,RX,R1,SD,SE,SH,SHE,SHEZ,SJ,SK,SN,SW,SWE,SX
							SXB,SXE,SXEB,S1,VA,VA2,VH,VSD,VX,VXB,VXE,VXEB,VXU,W1
			1	-	-	1227142	HEA2,HXQ4,HX26,LHQ4,LJG,LSS,LXE,LXQ4,LX16,PX26,QAE6,QAQ4,QAR2
							QHE4,QHP1,QHQ4,QH26,QME2,QSC9,QSE,QXC4,QXC6,QXC9,QXE4,QXE6,QXQ4
							QX26,RHE4,RHQ4,RH26,RXQ4,SHQ4,SJG,SMC4,SMD,SME1,SME6,SWC4,SXE4
							SXQ4,SX2,VD16,VEB6,VW22,VXB2,VXB6,VXE4,VXG,VXQ4,VX26
			-	(1)	-	1090816	-----
							V1



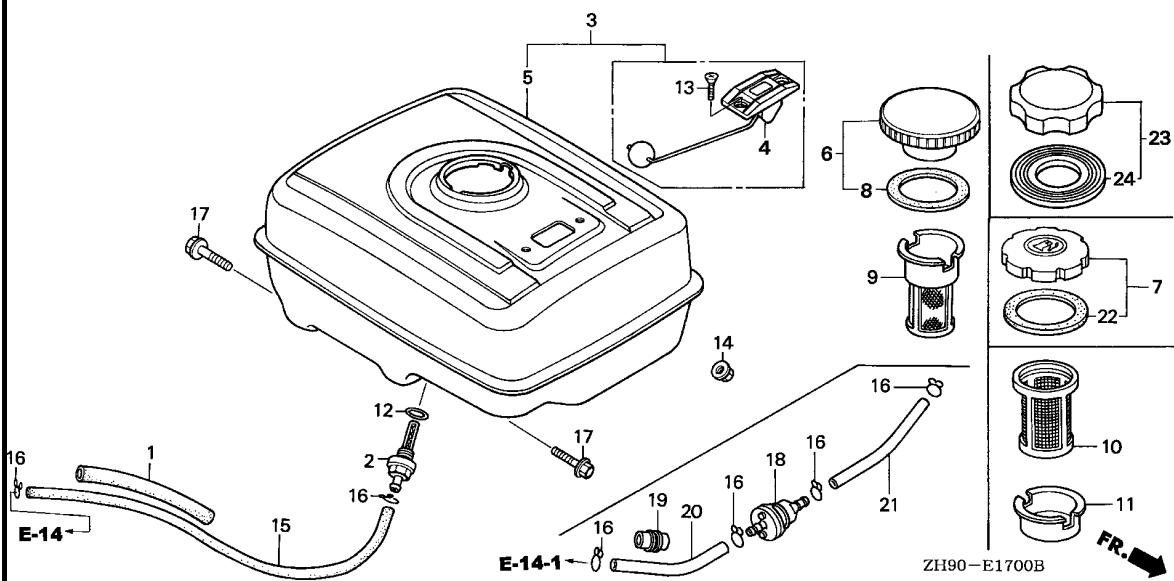

Ref. No.	Part No.	Description	Reqd. QTY			Serial No.	Parts catalogue code
			(1)	(2)	(3)		
(7)	17620-ZH7-023	CAP COMP., FUEL FILLER (BLACK)	1	(1)	-	1227143	HA,HAQ,HA2,HEA,HEA2,HH,HX,HXQ4,HX26,LH,LHE,LHQ4,LJ,LJG,LSS,LTJ,LW,LWD,LX,LXE,LXQ4,LXZ,LX16,L1,PA,PA2,PX,PX26,QA,QAE,QAE2,QAQ,QAQ4,QAR2,QA2,QD,QE,QH,QHC,QHE,QHE4,QHP1,QHQ4,QH26,QME2,QP,QSC,QSC9,QSE,QX,QXB,QXC,QXC4,QXC6,QXC9,QXE,QXEB,QXE4,QXE6,QXQ4,QX26,Q1,Q2,RA,RA2,RD,RH,RHE,RHE4,RHQ4,RH26,RX,RXQ4,R1,SD,SE,SH,SHE,SHEZ,SHQ4,SJ,SJG,SK,SMC4,SMD,SME1,SME6,SN,SW,SWC4,SWE,SX,SXB,SXE,SXEB,SXE4,SXQ4,SX2,S1,VA,VA2,VD16,VEB6,VH,VSD,VW22,VX,VXB,VXB2,VXB6,VXE,VXEB,VXE4,VXG,VXQ4,VXU,VX26,W1
			1	(1)	-	2118570	ES1/A,HA2/A,HEA2/A,HEA8/A,HX/A,HXQ4/A,HX26/A,HX8/A,LH/A,LHB5,LHE/A,LJ/A,LJC/A,LJG/A,LW/A,LWD1/A,LX/A,LXE/A,LXE8/A,LXQ4/A,LXU/A,L1/A,PAE2/A,PA2/A,PX/A,PXE8/A,PXU/A,PX26/A,QAE2/A,QAE6/A,QAG/A,QAG2/A,QAQ4/A,QAR2/A,QAW/A,QA2/A,QD/A,QE/A,QH/A,QHB5,QHE4/A,QHP1/A,QHQ4/A,QHR/A,QHR4/A,QH26/A,QKE3/A,QKE4,QME2/A,QMH/A,QP/A,QSC9/A,QSE/A,QSE2,QSE8/A,QWA4/A,QWH2/A,QX/A,QXB/A,QXB6/A,QXB7/A,QXC4/A,QXC6/A,QXC9/A,QXE/A,QXE4/A,QXE6/A,QXE8/A,QXQ4/A,QXU/A,QX26/A,Q1/A,RA2/A,RD/A,RHE4/A,RHQ4/A,RH26/A,RSS/A,RX/A,RXQ4/A,RXU/A,R1/A,SD/A,SE/A,SH/A,SHQ4/A,SJ/A,SJG/A,SMC4/A,SME1/A,SME6/A,SN/A,SWC4/A,SX/A,SXB/A,SXB7/A,SXE/A,SXEB/A,SXE4/A,SXE8/A,SXQ4/A,SXU/A,S1/A,VA2/A,VME2/A,VM2/A,VSD/A,VSD7/A,VX/A,VXB/A,VXB7/A,VXEB/A,VXE4/A,VXE6/A,VXE7/A,VXQ4/A,VXU/A,VXU1/A,WMT8/A,WXE8/A,W1/A
			1	-	-	-	ES1,HEA8,HX8,LJC,LWD1,LXE8,LXU,PAE2,PXE8,PXU,QAG,QAG2,QAW,QHR,QHR4,QKE3,QL2,QMH,QSE8,QWA2,QWA4,QWH2,QXB6,QXB7,QXE8,QXU,RSS,RXU,SXB7,SXE8,SXU,VME2,VM2,VSD7,VXB7,VXE6,VXE7,VXTB,VXU1,WMT8,WXE8

Ref. No.	Part No.	Description	Reqd. QTY			Serial No.	Parts catalogue code
			(1)	(2)	(3)		
8	17631-329-003	PACKING, FUEL FILLER CAP (39X58X3)	1	(1)	-	1010815	HH,HX,LH,LHE,LW,LX,LXZ,PX,QD,QE,QH,QHC,QHE,QP,QX,QXB,QXE,QXEB,Q2 RD,RH,RHE,RX,SD,SE,SH,SHE,SHEZ,SN,SW,SWE,SX,SB,SXE,SXEB,VH,VSD VX,VXB,VXE,VXEB,VXU
			1	(1)	-	1090815	HA,HAQ,HA2,HEA,LJ,LTJ,LWD,L1,PA,PA2,QA,QAE,QAE2,QAQ,QA2,QSC,QXC Q1,RA,RA2,R1,SJ,SK,S1,VA,VA2,V1,W1
			1	-	-	2118570	LHB1,LHB3,LT,QAB1,QAB3,QHZ,QT
9	17672-ZE2-W00 17672-ZE2-W01	FILTER, FUEL	1	(1)	-	1033679	LT/A,QAB3/A,QHZ/A,QT/A
			1	(1)	-	1033679	LJ,LW,L1,QE,QP,Q1,R1,SE,SJ,SK,SW,SWE,S1,V1,W1 ES1,ES1/A,HA2/A,HEA2,HEA2/A,HEA8,HEA8/A,LHB3,LJ/A,LJC,LJC/A,LJG LJG/A,LSS,LT,LT/A,LTJ,LW/A,LWD1,LWD1/A,L1/A,PAE2,PAE2/A,PA2/A QAB1,QAB3,QAB3/A,QAE2/A,QAE6,QAE6/A,QAG,QAG/A,QAG2,QAG2/A,QAQ4 QAQ4/A,QAR2,QAR2/A,QAW,QAW/A,QA2/A,QE/A,QKE3,QKE3/A,QKE4,QL2,QME2 QME2/A,QP/A,QT,QT/A,QX26,QX26/A,Q1/A,RA2/A,RSS,RSS/A,R1/A,SE/A SJ/A,SJG,SJG/A,SMC4,SMC4/A,SMD,SMX2,S1/A,VA2/A,VME2,VME2/A,VM2 VM2/A,VW22,WMA4,WMT8,WMT8/A,WXE8,WXE8/A,W1/A
10	17672-880-000	FILTER, FUEL	1	(1)	-	1065525	HA,HAQ,HA2,HEA,LJ,LW,L1,PA,PA2,QA,QAE,QAE2,QAQ,QA2,QE,QP,QSC,Q1 Q2,RA,RA2,R1,SE,SJ,SK,SW,SWE,S1,VA,VA2,V1,W1
			1	-	-	1241083	QSC9
			1	(1)	-	1065524	HA,HAQ,HA2,HEA,LJ,PA,PA2,QA,QAE,QAE2,QAQ,QA2,QSC,Q2,RA,RA2,SJ,SK VA,VA2
11	17673-893-000	HOLDER, FUEL FILTER	1	(1)	-	1033680	LW,L1,QE,QP,Q1,R1,SE,SW,SWE,S1,V1,W1
			1	-	-	1241084	QSC9/A
			1	-	-	1241084	QSC9
12	91353-671-004	O-RING, 14MM(NOK)	1	(1)	-	1065524	HA,HAQ,HA2,HEA,LJ,PA,PA2,QA,QAE,QAE2,QAQ,QA2,QSC,Q2,RA,RA2,SJ,SK VA,VA2
			1	(1)	-	1033680	LW,L1,QE,QP,Q1,R1,SE,SW,SWE,S1,V1,W1
			1	-	-	1241084	QSC9/A
13	93600-05010-0A	SCREW, FLAT, 5X10	-	(1)	-		ES1,ES1/A,HA,HAQ,HA2,HA2/A,HEA,HEA2,HEA2/A,HEA8,HEA8/A,HH,HX,HX/A HXQ4,HXQ4/A,HX26,HX26/A,HX8,HX8/A,LH,LH/A,LHB1,LHB3,LHB5,LHE LHE/A,LHQ4,LJ,LJ/A,LJC,LJC/A,LJG,LJG/A,LSS,LT,LT/A,LTJ,LW,LW/A LWD,LWD1,LWD1/A,LX,LX/A,LXE,LXE/A,LXE8,LXE8/A,LXQ4,LXQ4/A,LXU LXU/A,LXZ,LX16,PA,PAE2,PAE2/A,PA2,PA2/A,PX,PX/A,PXE8,PXE8/A,PXU PXU/A,PX26,PX26/A,QA,QAB1,QAB3,QAB3/A,QAE,QAE2,QAE2/A,QAE6,QAE6/A QAG,QAG/A,QAG2,QAG2/A,QAQ,QAQ4,QAQ4/A,QAR2,QAR2/A,QAW,QAW/A,QA2 QA2/A,QD,QD/A,QE,QE/A,QH,QH/A,QHB5,QHC,QHE,QHE4,QHE4/A,QHP1 QHP1/A,QHQ4,QHQ4/A,QHR,QHR/A,QHR4,QHR4/A,QHZ,QHZ/A,QH26,QH26/A QKE3,QKE3/A,QKE4,QL2,QME2,QME2/A,QMH,QMH/A,QP,QP/A,QSC,QSC9 QSC9/A,QSE,QSE/A,QSE2,QSE8,QSE8/A,QT,QT/A,QWA2,QWA4,QWA4/A,QWH2 QWH2/A,QX,QX/A,QXB,QXB/A,QXB6,QXB6/A,QXB7,QXB7/A,QXC,QXC4,QXC4/A QXC6,QXC6/A,QXC9,QXC9/A,QXE,QXE/A,QXEB,QXE4,QXE4/A,QXE6,QXE6/A QXE8,QXE8/A,QXQ4,QXQ4/A,QXU,QXU/A,QX26,QX26/A,RA,RA2,RA2/A,RD RD/A,RH,RHE,RHE4,RHE4/A,RHQ4,RHQ4/A,RH26,RH26/A,RSS,RSS/A,RX,RX/A RXQ4,RXQ4/A,RXU,RXU/A,SD,SD/A,SE,SE/A,SH,SH/A,SHE,SHEZ,SHQ4 SHQ4/A,SJ,SJ/A,SJG,SJG/A,SK,SMC4,SMC4/A,SMD,SME1,SME1/A,SME6 SME6/A,SMX2,SN,SN/A,SW,SWA4,SWC4,SWC4/A,SWE,SX,SX/A,SB,SB/A SB7,SB7/A,SXE,SXE/A,SXEB,SXEB/A,SXE4,SXE4/A,SXE8,SXE8/A,SXQ4 SXQ4/A,SXU,SXU/A,SX2,VA,VA2,VA2/A,VD16,VEB6,VH,VMA4,VME2,VME2/A VME4,VMS2,VMX2,VM2,VM2/A,VSD,VSD/A,VSD7,VSD7/A,VW22,VX,VX/A,VXB VXB/A,VXB2,VXB6,VXB7,VXB7/A,VXE,VXEB,VXEB/A,VXE4,VXE4/A,VXE6 VXE6/A,VXE7,VXE7/A,VXG,VXQ4,VXQ4/A,VXTB,VXU,VXU/A,VXU1,VXU1/A VX26,WMA4,WMT8,WMT8/A,WXE8,WXE8/A
			2	-	-		LJG,LJG/A,LSS,LTJ,LWD,LWD1,LWD1/A,QKE3,QKE3/A,QKE4,QSC,QSC9 QSC9/A,SJG,SJG/A,VXG



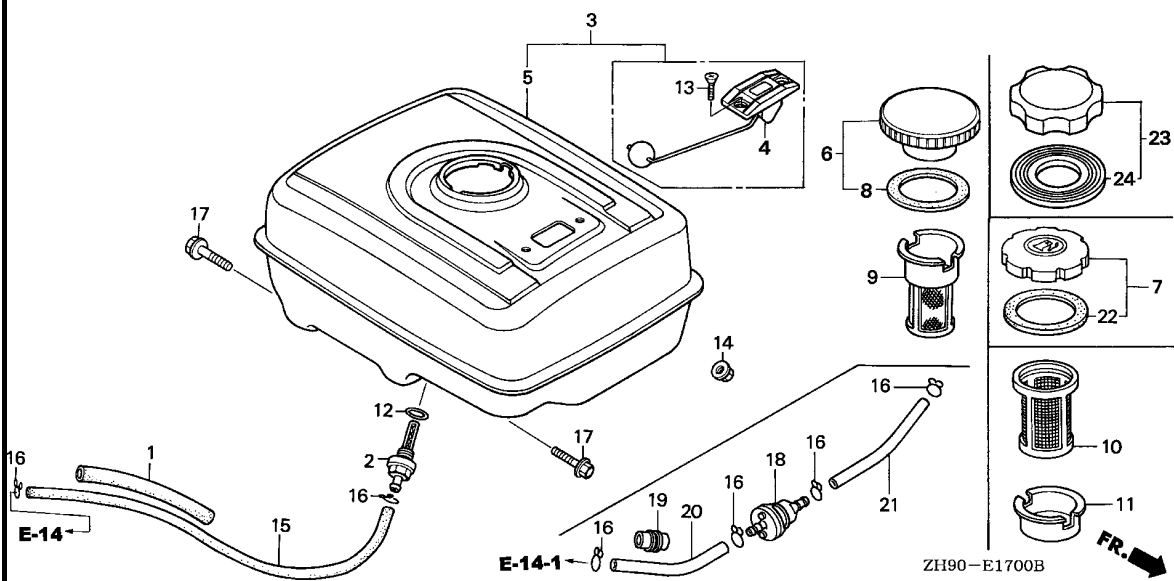

Ref. No.	Part No.	Description	Reqd. QTY			Serial No.	Parts catalogue code
			(1)	(2)	(3)		
14	94050-08000	NUT, FLANGE, 8MM	2	-	-	-----	ES1,ES1/A,HA,HAQ,HA2,HA2/A,HEA,HEA2,HEA2/A,HEA8,HEA8/A,HH,HX,HX/A,HXQ4,HXQ4/A,HX26,HX26/A,HX8,HX8/A,LH,LH/A,LHB1,LHB3,LHB5,LHE,LHE/A,LHQ4,LJ,LJ/A,LJC,LJC/A,LJG,LJG/A,LSS,LT,LT/A,LTJ,LW,LW/A,LWD,LWD1,LWD1/A,LX,LX/A,LXE,LXE/A,LXE8,LXE8/A,LXQ4,LXQ4/A,LXU,LXU/A,LXZ,LX16,PA,PAE2,PAE2/A,PA2,PA2/A,PX,PX/A,PXE8,PXE8/A,PXU,PXU/A,PX26,PX26/A,QA,QAB1,QAB3,QAB3/A,QAE,QAE2,QAE2/A,QAE6,QAE6/A,QAG,QAG/A,QAG2,QAG2/A,QAQ,QAQ4,QAQ4/A,QAR2,QAR2/A,QAW,QAW/A,QA2,QA2/A,QD,QD/A,QE,QE/A,QH,QH/A,QHB5,QHC,QHE,QHE4,QHE4/A,QHP1,QHP1/A,QHQ4,QHQ4/A,QHR,QHR/A,QHR4,QHR4/A,QHZ,QHZ/A,QH26,QH26/A,QKE3,QKE3/A,QKE4,QL2,QME2,QME2/A,QMH,QMH/A,QP,QP/A,QSC,QSC9,QSC9/A,QSE,QSE/A,QSE2,QSE8,QSE8/A,QT,QT/A,QWA2,QWA4,QWA4/A,QWH2,QWH2/A,QX,QX/A,QXB,QXB/A,QXB6,QXB6/A,QXB7,QXB7/A,QXC,QXC4,QXC4/A,QXC6,QXC6/A,QXC9,QXC9/A,QXE,QXE/A,QXEB,QXE4,QXE4/A,QXE6,QXE6/A,QXE8,QXE8/A,QXQ4,QXQ4/A,QXU,QXU/A,QX26,QX26/A,RA,RA2,RA2/A,RD,RD/A,RH,RHE,RHE4,RHE4/A,RHQ4,RHQ4/A,RH26,RH26/A,RSS,RSS/A,RX,RX/A,RXQ4,RXQ4/A,RXU,RXU/A,SD,SD/A,SE,SE/A,SH,SH/A,SHE,SHE2,SHQ4,SHQ4/A,SJ,SJ/A,SJG,SJG/A,SK,SKE1,SMC4,SMC4/A,SMD,SME1/A,SME6,SME6/A,SMX2,SN,SN/A,SW,SWA4,SWC4,SWC4/A,SWE,SX,SX/A,SXB,SXB/A,SXB7,SXB7/A,SXE,SXE/A,SXEB,SXEB/A,SXE4,SXE4/A,SXE8,SXE8/A,SXQ4,SXQ4/A,SXU,SXU/A,SX2,VA,VA2,VA2/A,VDE,VD16,VEB6,VH,VMA4,VME2,VME2/A,VME4,VMS2,VMX2,VM2,VM2/A,VPX7,VPX7/A,VSD,VSD/A,VSD7,VSD7/A,VS37,VS37/A,VW22,VX,VX/A,VXB,VXB/A,VXB2,VXB6,VXB7,VXB7/A,VXE,VXEB,VXEB/A,VXE4,VXE4/A,VXE6,VXE6/A,VXE7,VXG,VXQ4,VXQ4/A,VXTB,VXU,VXU/A,VXU1,VXU1/A,VX26,WMA4,WMT8,WMT8/A,WXE8,WXE8/A

- (2) -

Ref. No.	Part No.	Description	Reqd. QTY			Serial No.	Parts catalogue code
			(1)	(2)	(3)		
15	95001-45222-40	TUBE, FUEL, 4.5X222 (95001-45001-60M)	1	-	-	-----	ES1,ES1/A,HA,HAQ,HA2,HA2/A,HEA,HEA2,HEA2/A,HEA8,HEA8/A,HH,HX,HX/A HXQ4,HXQ4/A,HX26,HX26/A,HX8,HX8/A,LH,LH/A,LHB1,LHB3,LHB5,LHE LHE/A,LHQ4,LJ,LJ/A,LJC,LJC/A,LJG,LJG/A,LSS,LT,LT/A,LTJ,LW,LW/A LWD,LWD1,LWD1/A,LX,LX/A,LXE,LXE/A,LXE8,LXE8/A,LXQ4,LXQ4/A,LXU LXU/A,LXZ,LX16,PA,PAE2,PAE2/A,PA2,PA2/A,PX,PX/A,PXE8,PXE8/A,PXU PXU/A,PX26,PX26/A,QA,QAB1,QAB3,QAB3/A,QAE,QAE2,QAE2/A,QAE6,QAE6/A QAG,QAG/A,QAG2,QAG2/A,QAQ,QAQ4,QAQ4/A,QAR2,QAR2/A,QAW,QAW/A,QA2 QA2/A,QD,QD/A,QE,QE/A,QH,QH/A,QHB5,QHC,QHE,QHE4,QHE4/A,QHP1 QHP1/A,QHQ4,QHQ4/A,QHR,QHR/A,QHR4,QHR4/A,QHZ,QHZ/A,QH26,QH26/A QKE3,QKE3/A,QKE4,QL2,QME2,QME2/A,QMH,QMH/A,QP,QP/A,QSC,QSC9 QSC9/A,QSE,QSE/A,QSE2,QSE8,QSE8/A,QT,QT/A,QWA2,QWA4,QWA4/A,QWH2 QWH2/A,QX,QX/A,QXB,QXB/A,QXB6,QXB6/A,QXB7,QXB7/A,QXC,QXC4,QXC4/A QXC6,QXC6/A,QXC9,QXC9/A,QXE,QXE/A,QXEB,QXE4,QXE4/A,QXE6,QXE6/A QXE8,QXE8/A,QXQ4,QXQ4/A,QXU,QXU/A,QX26,QX26/A,RA,RA2,RA2/A,RD RD/A,RH,RHE,RHE4,RHE4/A,RHQ4,RHQ4/A,RH26,RH26/A,RSS,RSS/A,RX,RX/A RXQ4,RXQ4/A,RXU,RXU/A,SD,SD/A,SE,SE/A,SH,SH/A,SHE,SHE2,SHQ4 SHQ4/A,SJ,SJ/A,SJG,SJG/A,SK,SMC4,SMC4/A,SMD,SME1,SME1/A,SME6 SME6/A,SMX2,SN,SN/A,SW,SWA4,SWC4,SWC4/A,SWE,SX,SX/A,SXB,SXB/A SXB7,SXB7/A,SXE,SXE/A,SXEB,SXEB/A,SXE4,SXE4/A,SXE8,SXE8/A,SXQ4 SXQ4/A,SXU,SXU/A,SX2,VA,VAG2,VAG2/A,VAW,VAW1,VA2,VA2/A,VDE,VDE2 VDE2/A,VD16,VEB6,VH,VKB2,VKB2/A,VMA4,VME2,VME2/A,VME4,VMS2,VMX2 VM2,VM2/A,VNG1,VNG1/A,VNT2,VNT2/A,VN17,VN17/A,VSD,VSD/A,VSD7 VSD7/A,VSH7,VWN2,VWN2/A,VW12,VW12/A,VW22,VX,VX/A,VXB,VXB/A,VXB2 VXB6,VXB7,VXB7/A,VXE,VXEB,VXEB/A,VXE4,VXE4/A,VXE6,VXE6/A,VXE7 VXE7/A,VXG,VXQ4,VXQ4/A,VXTB,VXU,VXU/A,VXU1,VXU1/A,VX26,WMA4,WMT8 WMT8/A,WXE8,WXE8/A
			-	(1)	-		
	95001-45430-40	TUBE, FUEL, 4.5X430 (95001-45001-60M)	1	-	-	-----	VSD3,VSD3/A,VS37,VS37/A

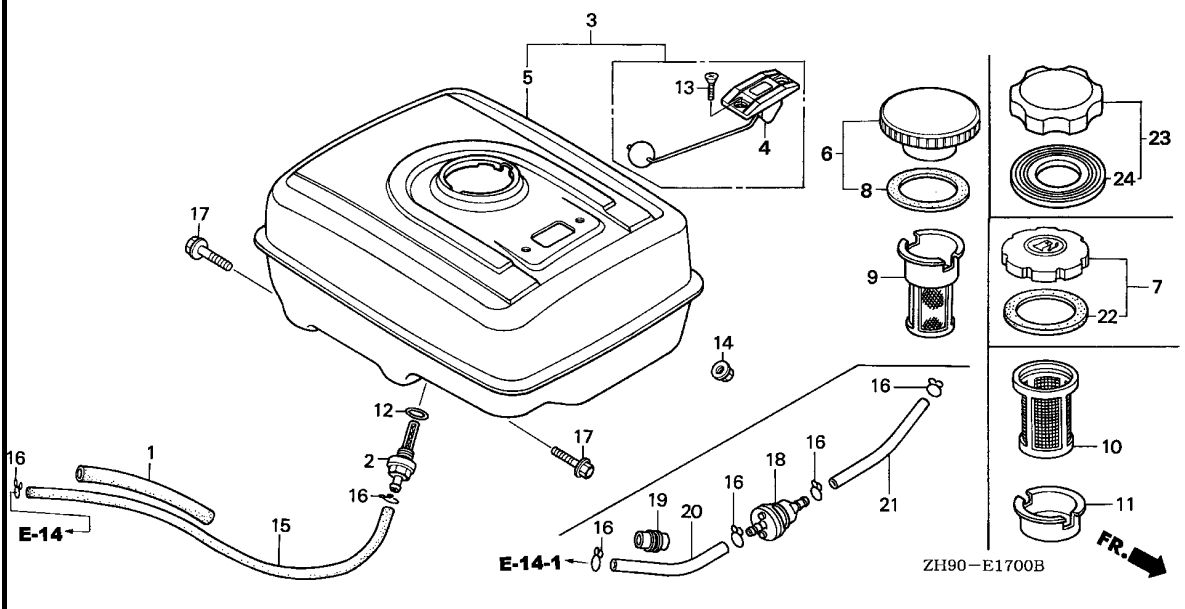

Ref. No.	Part No.	Description	Reqd. QTY			Serial No.	Parts catalogue code
			(1)	(2)	(3)		
16	95002-02080	CLIP, TUBE (B8)	2	-	-	-----	ES1, ES1/A, HA, HAQ, HA2, HA2/A, HEA, HEA2, HEA2/A, HEA8, HEA8/A, HH, HX, HX/A, HXQ4, HXQ4/A, HX26, HX26/A, HX8, HX8/A, LH, LH/A, LHB1, LHB3, LHB5, LHE, LHE/A, LHQ4, LJ, LJ/A, LJC, LJC/A, LJG, LJG/A, LSS, LT, LT/A, LTJ, LW, LW/A, LWD, LWD1, LWD1/A, LX, LX/A, LXE, LXE/A, LXE8, LXE8/A, LXQ4, LXQ4/A, LXU, LXU/A, LXZ, LX16, PA, PAE2, PAE2/A, PA2, PA2/A, PX, PX/A, PXE8, PXE8/A, PXU, PXU/A, PX26, PX26/A, QA, QAB1, QAB3, QAB3/A, QAE, QAE2, QAE2/A, QAE6, QAE6/A, QAG, QAG/A, QAG2, QAG2/A, QAQ, QAQ4, QAQ4/A, QAR2, QAR2/A, QAW, QAW/A, QA2, QA2/A, QD, QD/A, QE, QE/A, QH, QH/A, QHB5, QHC, QHE, QHE4, QHE4/A, QHP1, QHP1/A, QHQ4, QHQ4/A, QHR, QHR/A, QHR4, QHR4/A, QHZ, QHZ/A, QH26, QH26/A, QKE3, QKE3/A, QKE4, QL2, QME2, QME2/A, QMH, QMH/A, QP, QP/A, QSC, QSC9, QSC9/A, QSE, QSE/A, QSE2, QSE8, QSE8/A, QT, QT/A, QWA2, QWA4, QWA4/A, QWH2, QWH2/A, QX, QX/A, QXB, QXB/A, QXB6, QXB6/A, QXB7, QXB7/A, QXC, QXC4, QXC4/A, QXC6, QXC6/A, QXC9, QXC9/A, QXE, QXE/A, QXEB, QXE4, QXE4/A, QXE6, QXE6/A, QXE8, QXE8/A, QXQ4, QXQ4/A, QXU, QXU/A, QX26, QX26/A, RA, RA2, RA2/A, RD, RD/A, RH, RHE, RHE4, RHE4/A, RHQ4, RHQ4/A, RH26, RH26/A, RSS, RSS/A, RX, RX/A, RXQ4, RXQ4/A, RXU, RXU/A, SD, SD/A, SE, SE/A, SH, SH/A, SHE, SHE2, SHQ4, SHQ4/A, SJ, SJ/A, SJG, SJG/A, SK, SMC4, SMC4/A, SMD, SME1, SME1/A, SME6, SME6/A, SMX2, SN, SN/A, SW, SWA4, SWC4, SWC4/A, SWE, SX, SX/A, SXB, SXB/A, SXB7, SXB7/A, SXE, SXE/A, SXEB, SXEB/A, SXE4, SXE4/A, SXE8, SXE8/A, SXQ4, SXQ4/A, SXU, SXU/A, SX2, VA, VAG2, VAG2/A, VAW, VAW1, VA2, VA2/A, VDE, VDE2, VDE2/A, VD16, VEB6, VH, VKB2, VKB2/A, VMA4, VME2, VME2/A, VME4, VMS2, VMT, VMT/A, VMX2, VM2, VM2/A, VNG1, VNG1/A, VNT2, VNT2/A, VN17, VN17/A, VSD, VSD/A, VSD3, VSD3/A, VSD7, VSD7/A, VSH7, VS37, VS37/A, VWN2, VWN2/A, VW12, VW12/A, VW22, VX, VX/A, VXB, VXB/A, VXB2, VXB6, VXB7, VXB7/A, VXE, VXE8, VXE8/A, VXE4, VXE4/A, VXE6, VXE6/A, VXE7, VXE7/A, VXG, VXQ4, VXQ4/A, VXTB, VXU, VXU/A, VXU1, VXU1/A, VX26, WMA4, WMT8, WMT8/A, WXE8, WXE8/A, VKE4, VKX4, VPE4, VPE4/A, VPE5, VPE7, VPE7/A, VPX4, VPX4/A, VPX5, VPX7, VPX7/A
			4	-	-	-----	
			-	(2)	-	-----	

Ref. No.	Part No.	Description	Reqd. QTY			Serial No.	Parts catalogue code
			(1)	(2)	(3)		
17	95900-08025-00	BOLT, FLANGE, 8X25	2	(2)	-	-----	HA,HH,HX,HX8,LH,LHE,LJ,LW,LX,LXU,LXZ,L1,PA,QA,QAE,QD,QE,QH,QHC QHE,QP,QX,QXB,QXC,QXE,QXEB,QXE8,QXU,Q1,Q2,RA,RD,RH,RHE,RX,RXU,R1 SD,SE,SH,SHE,SHEZ,SJ,SK,SW,SWE,SX,SXB,SXE,SXEB,SXE8,SXU,S1,VA,VH VX,VXB,VXE,VXEB,V1,W1
	95701-08025-00	2	(2)	-	-----	ES1,ES1/A,HAQ,HA2,HA2/A,HEA,HEA2,HEA2/A,HEA8,HEA8/A,HX/A,HXQ4 HXQ4/A,HX26,HX26/A,HX8/A,LH/A,LHB1,LHB3,LHB5,LHE/A,LHQ4,LJ/A,LJC LJC/A,LJG,LJG/A,LSS,LT,LT/A,LTJ,LW/A,LWD,LWD1,LWD1/A,LX/A,LXE LXE/A,LXE8,LXE8/A,LXQ4,LXQ4/A,LXU/A,LX16,L1/A,PAE2,PAE2/A,PA2 PA2/A,PX,PX/A,PXE8,PXE8/A,PXU,PXU/A,PX26,PX26/A,QAB1,QAB3,QAB3/A QAE2,QAE2/A,QAE6,QAE6/A,QAG,QAG/A,QAG2,QAG2/A,QAQ,QAQ4,QAQ4/A QAR2,QAR2/A,QAW,QAW/A,QA2,QA2/A,QD/A,QE/A,QH/A,QHB5,QHE4,QHE4/A QHP1,QHP1/A,QHQ4,QHQ4/A,QHR,QHR/A,QHR4,QHR4/A,QHZ,QHZ/A,QH26 QH26/A,QKE3,QKE3/A,QKE4,QL2,QME2,QME2/A,QMH,QMH/A,QP/A,QSC,QSC9 QSC9/A,QSE,QSE/A,QSE2,QSE8,QSE8/A,QT,QT/A,QWA2,QWA4,QWA4/A,QWH2 QWH2/A,QX/A,QXB/A,QXB6,QXB6/A,QXB7,QXB7/A,QXC4,QXC4/A,QXC6,QXC6/A QXC9,QXC9/A,QXE/A,QXE4,QXE4/A,QXE6,QXE6/A,QXE8/A,QXQ4,QXQ4/A QXU/A,QX26,QX26/A,Q1/A,RA2,RA2/A,RD/A,RHE4,RHE4/A,RHQ4,RHQ4/A RH26,RH26/A,RSS,RSS/A,RX/A,RXQ4,RXQ4/A,RXU/A,R1/A,SD/A,SE/A,SH/A SHQ4,SHQ4/A,SJ/A,SJG,SJG/A,SMC4,SMC4/A,SMD,SME1,SME1/A,SME6 SME6/A,SMX2,SN,SN/A,SWA4,SWC4,SWC4/A,SX/A,SXB/A,SXB7,SXB7/A,SXE/A SXEB/A,SXE4,SXE4/A,SXE8/A,SXQ4,SXQ4/A,SXU/A,SX2,S1/A,VA2,VA2/A VD16,VEB6,VMA4,VME2,VME2/A,VME4,VM2,VM2/A,VSD,VSD/A,VSD7,VSD7/A VW22,VX/A,VXB/A,VXB2,VXB6,VXB7,VXB7/A,VXEB/A,VXE4,VXE4/A,VXE6 VXE6/A,VXE7,VXE7/A,VXG,VXQ4,VXQ4/A,VXTB,VXU,VXU/A,VXU1,VXU1/A VX26,WMA4,WMT8,WMT8/A,WXE8,WXE8/A,W1/A
18	16910-GB2-005	STRAINER COMP., FUEL	1	-	-	-----	VKE4,VKX4,VPE4,VPE4/A,VPE5,VPE7,VPE7/A,VPX4,VPX4/A,VPX5,VPX7 VPX7/A
19	90854-ZB3-000	RUBBER, FUEL (9X15X20)	1	-	-	-----	VKE4,VKX4,VPE4,VPE4/A,VPE5,VPE7,VPE7/A,VPX4,VPX4/A,VPX5,VPX7 VPX7/A
20	95001-45120-40	TUBE, FUEL, 4.5X120 (95001-45001-60M)	1	-	-	-----	VKE4,VKX4,VPE4,VPE4/A,VPE5,VPE7,VPE7/A,VPX4,VPX4/A,VPX5,VPX7 VPX7/A
21	95001-45150-40	TUBE, FUEL, 4.5X150 (95001-45001-60M)	1	-	-	-----	VKE4,VKX4,VPE4,VPE4/A,VPE5,VPE7,VPE7/A,VPX4,VPX4/A,VPX5,VPX7 VPX7/A



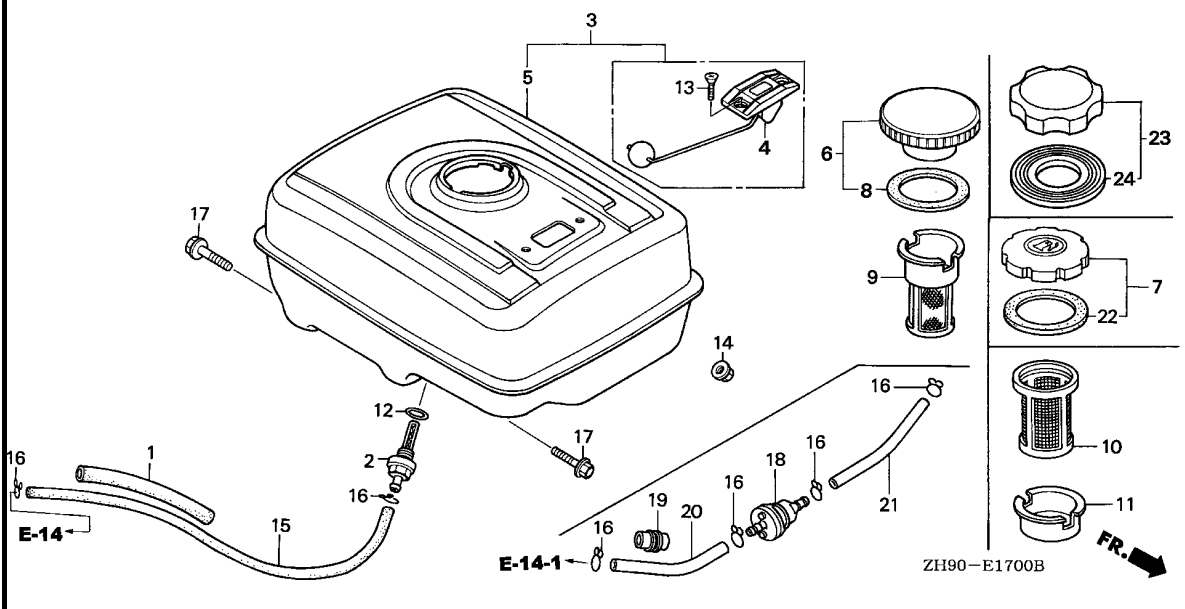

Ref. No.	Part No.	Description	Reqd. QTY			Serial No.	Parts catalogue code
			(1)	(2)	(3)		
22	17631-ZH7-003	PACKING, FUEL FILLER CAP (39X58X3)	1	(1)	-	1010816	----- HH, HX, LH, LHE, LW, LX, LXZ, PX, QD, QE, QH, QHC, QHE, QP, QX, QXB, QXE, QXEB, Q2 RD, RH, RHE, RX, SD, SE, SH, SHE, SHEZ, SN, SW, SWE, SX, SXB, SXE, SXEB, VH, VSD VX, VXB, VXE, VXEB, VXU
			1	(1)	-	1090816	----- HA, HAQ, HA2, HEA, LJ, LTJ, LWD, L1, PA, PA2, QA, QAE, QAE2, QAQ, QA2, QSC, QXC Q1, RA, RA2, R1, SJ, SK, S1, VA, VA2, V1, W1
			1	(1)	-	2118570	----- ES1/A, HA2/A, HEA2/A, HEA8/A, HX/A, HXQ4/A, HX26/A, HX8/A, LH/A, LHB5 LHE/A, LJ/A, LJC/A, LJG/A, LW/A, LWD1/A, LX/A, LXE/A, LXE8/A, LXQ4/A, LXU/A L1/A, PAE2/A, PA2/A, PX/A, PXE8/A, PXU/A, PX26/A, QAE2/A, QAE6/A, QAG/A QAG2/A, QAQ4/A, QAR2/A, QAW/A, QA2/A, QD/A, QE/A, QH/A, QHB5, QHE4/A QHP1/A, QHQ4/A, QHR/A, QHR4/A, QH26/A, QKE3/A, QKE4, QME2/A, QMH/A, QP/A QSC9/A, QSE/A, QSE2, QSE8/A, QWA4/A, QWH2/A, QX/A, QXB/A, QXB6/A, QXB7/A QXC4/A, QXC6/A, QXC9/A, QXE/A, QXE4/A, QXE6/A, QXE8/A, QXQ4/A, QXU/A QX26/A, Q1/A, RA2/A, RD/A, RHE4/A, RHQ4/A, RH26/A, RSS/A, RX/A, RXQ4/A RXU/A, R1/A, SD/A, SE/A, SH/A, SHQ4/A, SJ/A, SJG/A, SMC4/A, SME1/A, SME6/A SN/A, SWC4/A, SX/A, SXB/A, SXB7/A, SXE/A, SXEB/A, SXE4/A, SXE8/A, SXQ4/A SXU/A, S1/A, VA2/A, VME2/A, VM2/A, VSD/A, VSD7/A, VX/A, VXB/A, VXB7/A VXEB/A, VXE4/A, VXE6/A, VXE7/A, VXQ4/A, VXU/A, VXU1/A, WMT8/A, WXE8/A W1/A
			1	-	-	-----	ES1, HEA2, HEA8, HXQ4, HX26, HX8, LHQ4, LJC, LJG, LSS, LWD1, LXE, LXE8, LXQ4 LXU, LX16, PAE2, PXE8, PXU, PX26, QAE6, QAG, QAG2, QAQ4, QAR2, QAW, QHE4, QHP1 QHQ4, QHR, QHR4, QH26, QKE3, QL2, QME2, QMH, QSC9, QSE, QSE8, QWA4, QWA4, QWH2 QXB6, QXB7, QXC4, QXC6, QXC9, QXE4, QXE6, QXE8, QXQ4, QXU, QX26, RHE4, RHQ4 RH26, RSS, RXQ4, RXU, SHQ4, SJG, SMC4, SMD, SME1, SME6, SWC4, SXB7, SXE4, SXE8 SXQ4, SXU, SX2, VD16, VEB6, VME2, VM2, VSD7, VM22, VXB2, VXB6, VXB7, VXE4 VXE6, VXE7, VVG, VXQ4, VXTB, VXU1, VX26, WMT8, WXE8

Ref. No.	Part No.	Description	Reqd. QTY			Serial No.	Parts catalogue code
			(1)	(2)	(3)		
23	17620-ZOT-305	CAP COMP., FUEL FILLER (CHROME PLATED)	1	(1)	-	2118571 -----	ES1/A,HA2/A,HEA2/A,HEA8/A,HX/A,HXQ4/A,HX26/A,HX8/A,LH/A,LHB5 LHE/A,LJ/A,LJC/A,LJG/A,LT/A,LW/A,LWD1/A,LX/A,LXE/A,LXE8/A,LXQ4/A LXU/A,L1/A,PAE2/A,PA2/A,PX/A,PXE8/A,PXU/A,PX26/A,QAB3/A,QAE2/A QAE6/A,QAG/A,QAG2/A,QAQ4/A,QAR2/A,QAW/A,QA2/A,QD/A,QE/A,QH/A,QHB5 QHE4/A,QHP1/A,QHQ4/A,QHR/A,QHR4/A,QHZ/A,QH26/A,QKE3/A,QKE4,QME2/A QMH/A,QP/A,QSC9/A,QSE/A,QSE2,QSE8/A,QT/A,QWA4/A,QWH2/A,QX/A,QXB/A QXB6/A,QXB7/A,QXC4/A,QXC6/A,QXC9/A,QXE/A,QXE4/A,QXE6/A,QXE8/A QXQ4/A,QXU/A,QX26/A,Q1/A,RA2/A,RD/A,RHE4/A,RHQ4/A,RH26/A,RSS/A RX/A,RXQ4/A,RXU/A,R1/A,SD/A,SE/A,SH/A,SHQ4/A,SJ/A,SJG/A,SMC4/A SME1/A,SME6/A,SN/A,SWC4/A,SX/A,SXB/A,SXB7/A,SXE/A,SXEB/A,SXE4/A SXE8/A,SXQ4/A,SXU/A,S1/A,VA2/A,VME2/A,VM2/A,VSD/A,VSD7/A,VX/A VXB/A,VXB7/A,VXEB/A,VXE4/A,VXE6/A,VXE7/A,VXQ4/A,VXU/A,VXU1/A WMT8/A,WXE8/A,W1/A SMX2,SWA4,VMA4,VME4,WMA4
24	17631-ZOT-812	PACKING, FUEL FILLER CAP (39X62X3)	1	(1)	-	2118571 -----	ES1/A,HA2/A,HEA2/A,HEA8/A,HX/A,HXQ4/A,HX26/A,HX8/A,LH/A,LHB5 LHE/A,LJ/A,LJC/A,LJG/A,LT/A,LW/A,LWD1/A,LX/A,LXE/A,LXE8/A,LXQ4/A LXU/A,L1/A,PAE2/A,PA2/A,PX/A,PXE8/A,PXU/A,PX26/A,QAB3/A,QAE2/A QAE6/A,QAG/A,QAG2/A,QAQ4/A,QAR2/A,QAW/A,QA2/A,QD/A,QE/A,QH/A,QHB5 QHE4/A,QHP1/A,QHQ4/A,QHR/A,QHR4/A,QHZ/A,QH26/A,QKE3/A,QKE4,QME2/A QMH/A,QP/A,QSC9/A,QSE/A,QSE2,QSE8/A,QT/A,QWA4/A,QWH2/A,QX/A,QXB/A QXB6/A,QXB7/A,QXC4/A,QXC6/A,QXC9/A,QXE/A,QXE4/A,QXE6/A,QXE8/A QXQ4/A,QXU/A,QX26/A,Q1/A,RA2/A,RD/A,RHE4/A,RHQ4/A,RH26/A,RSS/A RX/A,RXQ4/A,RXU/A,R1/A,SD/A,SE/A,SH/A,SHQ4/A,SJ/A,SJG/A,SMC4/A SME1/A,SME6/A,SN/A,SWC4/A,SX/A,SXB/A,SXB7/A,SXE/A,SXEB/A,SXE4/A SXE8/A,SXQ4/A,SXU/A,S1/A,VA2/A,VME2/A,VM2/A,VSD/A,VSD7/A,VX/A VXB/A,VXB7/A,VXEB/A,VXE4/A,VXE6/A,VXE7/A,VXQ4/A,VXU/A,VXU1/A WMT8/A,WXE8/A,W1/A SMX2,SWA4,VMA4,VME4,WMA4



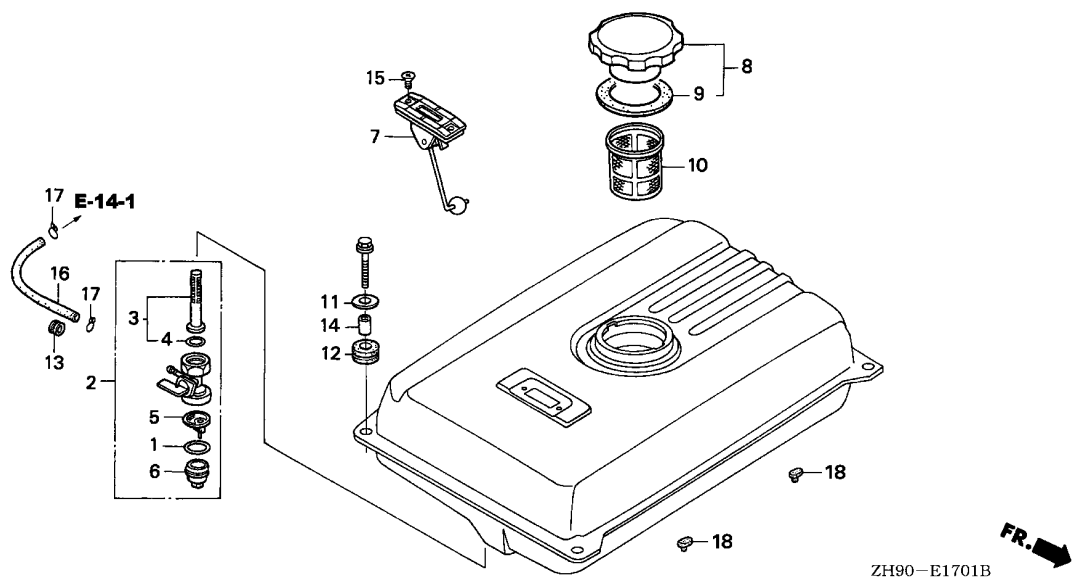

Ref. No.	L.O.N.	(Relative ref. Number) Description	F.R.T.
3	3101D5	SCREEN, FUEL STRAINER	0.2
5	3101A7	FILTER, FUEL TANK CUP	0.2
7	6171A1	METER/GAUGE UNIT, FUEL	0.1
10	3101A6	FILTER, FUEL	0.1
16	3101F2	TUBE, FUEL COCK	0.2

Ref. No.	Part No.	Description	Reqd. QTY			Serial No.	Parts catalogue code
			(1)	(2)	(3)		
1	16173-001-004	PACKING, FUEL STRAINER CUP ..	1	-	-	-----	ES3,ES3/A,VS3
2	16950-ZB4-015	COCK ASSY., FUEL	1	-	-	-----	ES3,ES3/A,VS3
3	16952-ZB4-005	SCREEN, FUEL STRAINER	1	-	-	-----	ES3,ES3/A,VS3
4	16958-397-771	O-RING	1	-	-	-----	ES3,ES3/A,VS3
5	16959-471-831	FILTER, CUP	1	-	-	-----	ES3,ES3/A,VS3
6	16967-GA6-671	CUP, FUEL STRAINER	1	-	-	-----	ES3,ES3/A,VS3
7	17505-ZB2-003	METER ASSY., FUEL	1	-	-	-----	ES3,ES3/A,VS3
8	17620-899-013	CAP COMP., FUEL FILLER	1	-	-	-----	ES3,ES3/A,VS3
9	17631-899-000	PACKING, FUEL FILLER CAP	1	-	-	-----	ES3,ES3/A,VS3
10	17670-899-000	FILTER COMP., FUEL	1	-	-	-----	ES3,ES3/A,VS3
11	90503-898-000	WASHER, TANK CUSHION	4	-	-	-----	ES3,ES3/A,VS3
12	90851-898-000	RUBBER, TANK CUSHION	4	-	-	-----	ES3,ES3/A,VS3
13	90854-ZB2-000	RUBBER, FUEL (9X15X10)	1	-	-	-----	ES3,ES3/A,VS3
14	91551-898-000	COLLAR, TANK CUSHION	4	-	-	-----	ES3,ES3/A,VS3
15	93600-05010-0A	SCREW, FLAT, 5X10	2	-	-	-----	ES3,ES3/A
16	95001-45150-40	TUBE, FUEL, 4.5X150 (95001-45001-60M)	1	-	-	-----	ES3,ES3/A,VS3
17	95002-02080	CLIP, TUBE (B8)	2	-	-	-----	ES3,ES3/A,VS3
18	76122-952-000	STOPPER, DISCHARGE GUARD	4	-	-	-----	VS3

2

E-17-2

FUEL TANK(3)

2-B 2

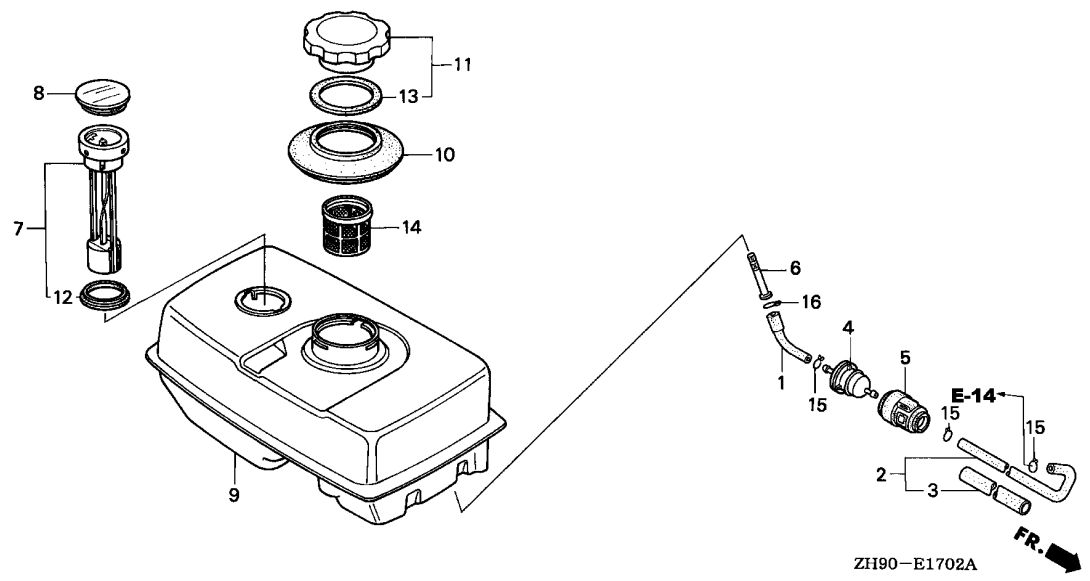

Ref. No.	L.O.N.	(Relative ref. Number) Description	F.R.T.
1	3101F1	TUBE, FUEL TANK	0.2
2	3101Q7	TUBE, FUEL STRAINER(A)	0.2
4	3101K6	STRAINER, FUEL(A)	0.2
6	3101H6	JOINT, FUEL STRAINER	0.2
7	6171A1	METER/GAUGE UNIT, FUEL	0.1
9	3101H7	TANK, FUEL	0.2
14	3101A6	FILTER, FUEL	0.1

Ref. No.	Part No.	Description	Reqd. QTY			Serial No.	Parts catalogue code
			(1)	(2)	(3)		
1	16852-ZB6-000	TUBE, FUEL TANK	1	-	-	-----	SJP
2	16854-ZB6-000	TUBE ASSY., COCK-CARBURETOR ..	1	-	-	-----	SJP
3	16857-ZB6-000	RUBBER, SUPPORTER	1	-	-	-----	SJP
4	16910-GB2-005	STRAINER COMP., FUEL	1	-	-	-----	SJP
5	16915-GB2-000	SUSPENSION, STRAINER	1	-	-	-----	SJP
6	16952-ZB6-000	BUSH, FUEL PURGE	1	-	-	-----	SJP
7	17505-898-023	METER COMP., FUEL	1	-	-	-----	SJP
8	17507-ZA0-800	CAP, FUEL METER	1	-	-	-----	SJP
9	17510-ZB6-010	TANK COMP., FUEL	1	-	-	-----	SJP
10	17520-ZA0-800	SEAL, FUEL FILLER NECK	1	-	-	-----	SJP
11	17620-899-013	CAP COMP., FUEL FILLER	1	-	-	-----	SJP
12	17624-187-020	PACKING C, FUEL METER	1	-	-	-----	SJP
13	17631-899-000	PACKING, FUEL FILLER CAP	1	-	-	-----	SJP
14	17670-ZB6-000	FILTER COMP., FUEL	1	-	-	-----	SJP
15	95002-02080	CLIP, TUBE (B8)	3	-	-	-----	SJP
16	95002-02100	CLIP, TUBE (B10)	1	-	-	-----	SJP

2

E-17-3

FUEL TANK(4)

2-B 3

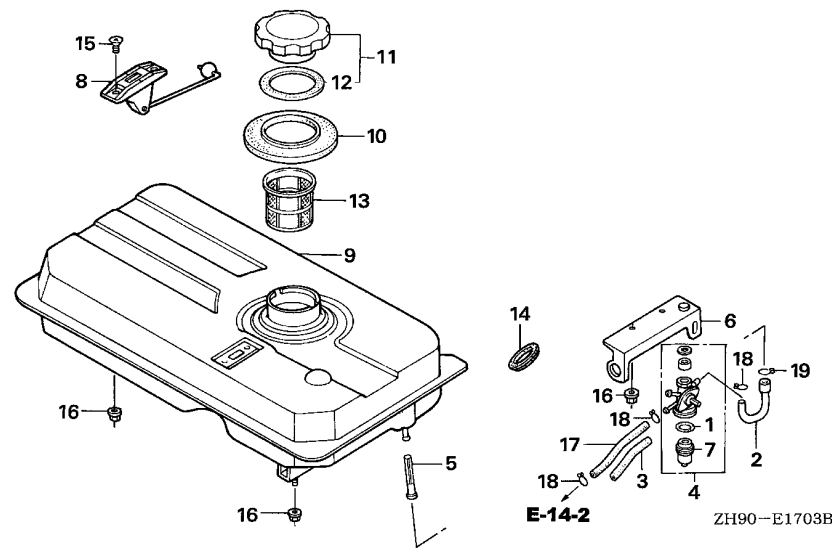

Ref. No.	L.O.N.	(Relative ref. Number) Description	F.R.T.
1	3101L6	PACKING, FUEL STRAINER CUP ...	0.2
2	3101F1	TUBE, FUEL TANK	0.2
4	3101A3	COCK, FUEL	0.2
5	3101K6	STRAINER, FUEL(A)	0.2
8	6171A1	METER/GAUGE UNIT, FUEL	0.1
9	3101D0	TANK, FUEL(A)	0.3
13	3101A6	FILTER, FUEL	0.1
17	3101F2	TUBE, FUEL COCK	0.2

Ref. No.	Part No.	Description	Reqd. QTY			Serial No.	Parts catalogue code
			(1)	(2)	(3)		
1	16173-001-004	PACKING, FUEL STRAINER CUP ..	1	-	-	ESS,ESS/A	
2	16851-ZB7-700	TUBE, FUEL (TANK-COCK)	1	-	-	ESS,ESS/A	
3	16857-ZB7-000	TUBE, FUEL SUPPORTER	1	-	-	ESS,ESS/A	
4	16950-ZA0-803	COCK ASSY., FUEL	1	-	-	ESS,ESS/A	
5	16952-ZB7-000	STRAINER, FUEL	1	-	-	ESS,ESS/A	
6	16956-ZB7-700	BRACKET, FUEL COCK	1	-	-	ESS,ESS/A	
7	16967-MA2-771	CUP, FUEL STRAINER	1	-	-	ESS,ESS/A	
8	17505-ZB2-003	METER ASSY., FUEL	1	-	-	ESS,ESS/A	
9	17510-ZB7-000	TANK COMP., FUEL	1	-	-	ESS,ESS/A	
10	17520-ZA0-800	SEAL, FUEL FILLER NECK	1	-	-	ESS,ESS/A	
11	17620-899-013	CAP COMP., FUEL FILLER	1	-	-	ESS,ESS/A	
12	17631-899-000	PACKING, FUEL FILLER CAP	1	-	-	ESS,ESS/A	
13	17670-899-000	FILTER COMP., FUEL	1	-	-	ESS,ESS/A	
14	32112-611-000	GROMMET, WIRE CORD	1	-	-	ESS,ESS/A	
15	93600-05010-0A	SCREW, FLAT, 5X10	2	-	-	ESS,ESS/A	
16	94050-06000	NUT, FLANGE, 6MM	6	-	-	ESS,ESS/A	
17	95001-45250-40	TUBE, FUEL, 4.5X250 (95001-45001-60M)	1	-	-	ESS,ESS/A	
18	95002-02080	CLIP, TUBE (B8)	3	-	-	ESS,ESS/A	
19	95002-02100	CLIP, TUBE (B10)	1	-	-	ESS,ESS/A	

2

FR.

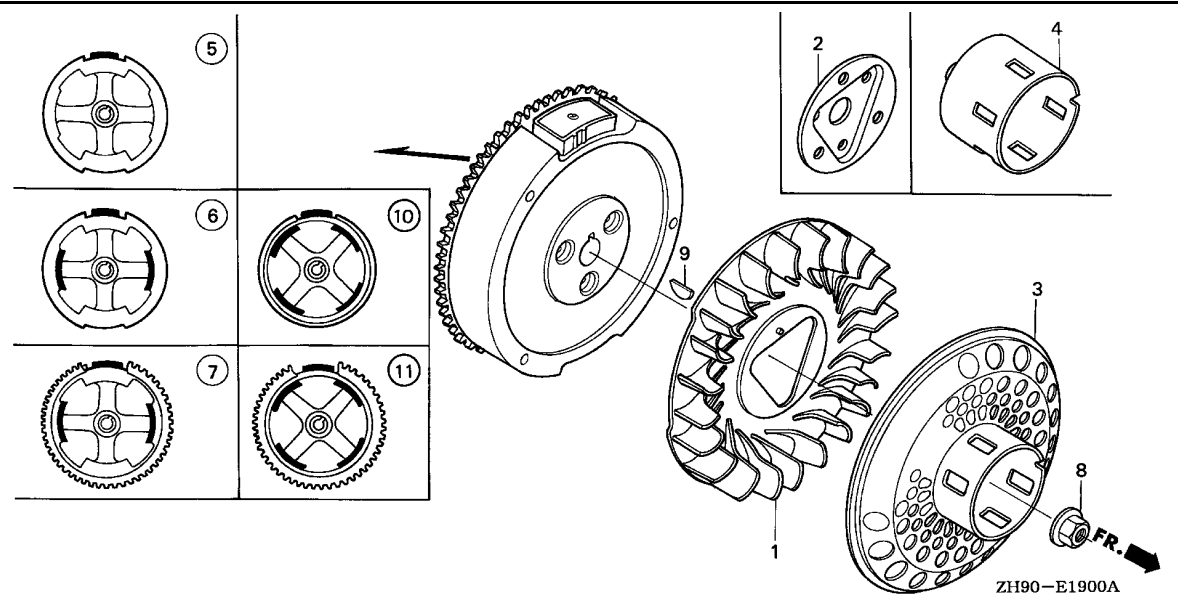

Ref. No.	L.O.N.	(Relative ref. Number) Description	F.R.T.
1	1141G7	FAN, ENGINE COOLING	0.2
3	1121A9	PULLEY, RECOIL STARTER	0.2
5		(6,7,10,11)	
	2161B5	FLYWHEEL	0.3

Ref. No.	Part No.	Description	Reqd. QTY			Serial No.	Parts catalogue code
			(1)	(2)	(3)		
1	19511-ZE2-000	FAN, COOLING	1	1	1		
2	19512-ZE2-000	PLATE, COOLING FAN SETTING ..	1	-	-	-----	LWD,LWD1,LWD1/A,QKE3,QKE3/A,QKE4,SKE1
3	28450-ZE2-W11	PULLEY COMP., STARTER (SCREEN GRID)	1	-	-	-----	HA,HAQ,HA2,HA2/A,HEA,HEA2,HEA2/A,HEA8,HEA8/A,HH,HX,HX/A,HXQ4 HXQ4/A,HX26,HX26/A,HX8,HX8/A,LH,LH/A,LHB1,LHB3,LHB5,LHE,LHE/A LHQ4,LSS,LT,LT/A,LTJ,LW,LW/A,LX,LX/A,LXE,LXE/A,LXE8,LXE8/A,LXQ4 LXQ4/A,LXU,LXU/A,LXZ,LX16,PA,PAE2,PAE2/A,PA2,PA2/A,PX,PX/A,PXE8 PXE8/A,PXU,PXU/A,PX26,PX26/A,QA,QAB1,QAB3,QAB3/A,QAQ,QAQ2,QAQ2/A QAE6,QAQ6/A,QAG,QAG/A,QAQ,QAQ4,QAQ4/A,QAR2,QAR2/A,QAW,QAW/A,QA2 QA2/A,QE,QE/A,QH,QH/A,QHB5,QHC,QHE,QHE4,QHE4/A,QHP1,QHP1/A,QHQ4 QHQ4/A,QHR,QHR/A,QHR4,QHR4/A,QHZ,QHZ/A,QH26,QH26/A,QL2,QME2 QME2/A,QMH,QMH/A,QP,QP/A,QSC,QSC9,QSC9/A,QSE,QSE/A,QSE2,QSE8 QSE8/A,QWA2,QWH2,QWH2/A,QX,QX/A,QXB,QXB/A,QXB6,QXB6/A,QXB7,QXB7/A QXC,QXC4,QXC4/A,QXC6,QXC6/A,QXC9,QXC9/A,QXE,QXE/A,QXEB,QXE4 QXE4/A,QXE6,QXE6/A,QXE8,QXE8/A,QXQ4,QXQ4/A,QXU,QXU/A,QX26,QX26/A RA,RA2,RA2/A,RH,RHE,RHE4,RHE4/A,RHQ4,RHQ4/A,RH26,RH26/A,RSC2 RSC2/A,RSS,RSS/A,RX,RX/A,RXQ4,RXQ4/A,RXU,RXU/A,SE,SE/A,SH,SH/A SHE,SHEZ,SHQ4,SHQ4/A,SME1,SME1/A,SME6,SME6/A,SW,SWA4,SWC4,SWC4/A SWE,SX,SX/A,SXB,SXB/A,SXB7,SXB7/A,SXE,SXE/A,SXEB,SXEB/A,SXE4 SXE4/A,SXE8,SXE8/A,SXQ4,SXQ4/A,SXU,SXU/A,SX2,VA,VAW,VA2,VA2/A,VDE VDE2,VDE2/A,VD16,VEB6,VH,VKB2,VKB2/A,VKE4,VKX4,VME2,VME2/A,VMS2 VMX2,VM2,VM2/A,VNG1,VNG1/A,VN17,VN17/A,VPE4,VPE4/A,VPE5,VPE7 VPE7/A,VPX4,VPX4/A,VPX5,VPX7,VPX7/A,VSD,VSD/A,VSD3,VSD3/A,VSD7 VSD7/A,VSH7,VS37,VS37/A,VWA,VWA2,VWA2/A,VWN2,VWN2/A,VWT4,VWT4/A VW22,VX,VX/A,VXB,VXB/A,VXB2,VXB6,VXB7,VXB7/A,VXE,VXEB,VXEB/A,VXE4 VXE4/A,VXE6,VXE6/A,VXE7,VXE7/A,VXG,VXQ4,VXQ4/A,VXTB,VXT1,VXT1/A VXU,VXU/A,VXU1,VXU1/A,VX26

- (1) -



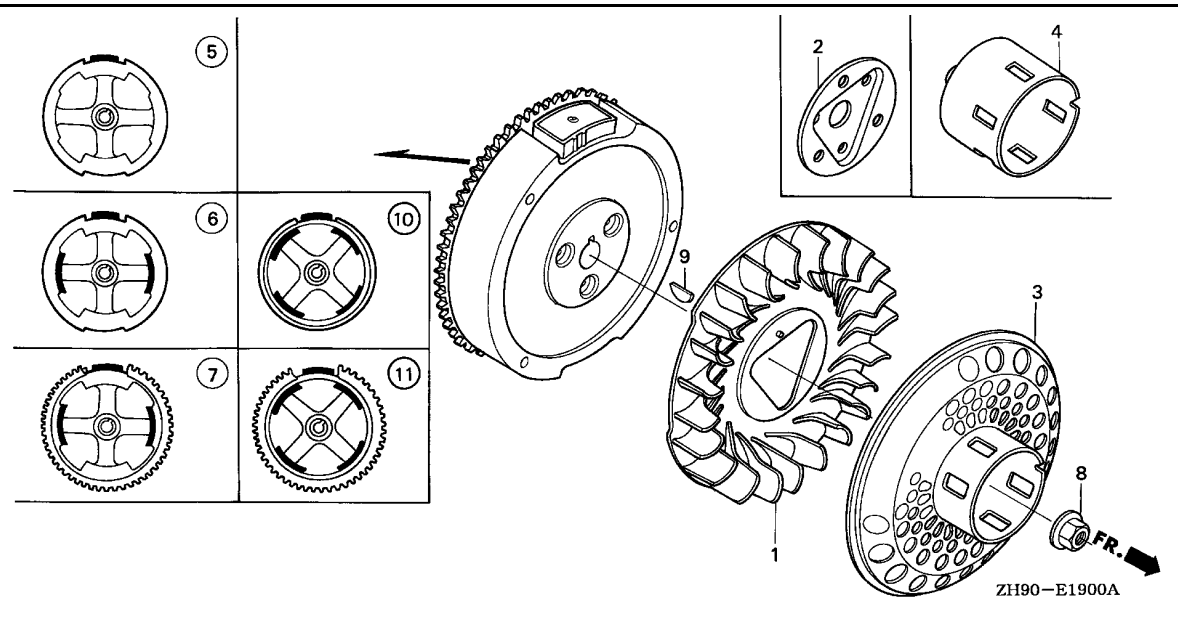

Ref. No.	Part No.	Description	Reqd. QTY			Serial No.	Parts catalogue code
			(1)	(2)	(3)		
4	28451-ZE2-W01	PULLEY, STARTER	1	(1)	-	-----	ESS,ESS/A,ES1,ES1/A,ES3,ES3/A,LJ,LJ/A,LJC,LJC/A,LJG,LJG/A,L1,L1/A,QAG2,QAG2/A,QD,QD/A,QSE2,QT,QT/A,QWA4,QWA4/A,Q1,Q1/A,RD,RD/A,R1,R1/A,SD,SD/A,SJ,SJ/A,SJG,SJG/A,SJP,SK,SMC4,SMC4/A,SMD,SMX2,SN,SN/A,S1,S1/A,VAG2,VAG2/A,VAW1,VMA4,VME4,VMT,VMT/A,VNT2,VNT2/A,VS3,VW12,VW12/A,V1,WMA4,WMT8,WMT8/A,WXE8,WXE8/A,W1,W1/A
5	31100-ZE2-010	FLYWHEEL COMP.	1	-	1	-----	ESS,ESS/A,ES1,ES1/A,ES3,ES3/A,HA,HAQ,HA2,HA2/A,HH,HX,HX/A,HXQ4,HXQ4/A,HX26,HX26/A,HX8,HX8/A,LH,LH/A,LHB1,LHB3,LHB5,LHQ4,LJ,LJ/A,LJC,LJC/A,LJG,LJG/A,LSS,LX,LX/A,LXQ4,LXQ4/A,LXU,LXU/A,LXZ,LX16,PA,PA2,PA2/A,PX,PX/A,PXU,PXU/A,PX26,PX26/A,QA,QAB1,QAB3,QAB3/A,QAG2,QAG2/A,QAQ,QAQ4,QAQ4/A,QAW,QAW/A,QA2,QA2/A,QD,QD/A,QE,QE/A,QH,QH/A,QHB5,QHC,QHP1,QHP1/A,QHQ4,QHQ4/A,QHZ,QHZ/A,QH26,QH26/A,QMH,QMH/A,QT,QT/A,QWA2,QWA4,QWA4/A,QWH2,QWH2/A,QX,QX/A,QXB,QXB/A,QXB7,QXB7/A,QXC,QXC4,QXC4/A,QXC6,QXC6/A,QXC9,QXC9/A,QXQ4,QXQ4/A,QXU,QXU/A,QX26,QX26/A,RA,RA2,RA2/A,RD,RD/A,RH,RHQ4,RHQ4/A,RH26,RH26/A,RX,RX/A,RXQ4,RXQ4/A,RXU,RXU/A,SD,SD/A,SE,SE/A,SH,SH/A,SHQ4,SHQ4/A,SJ,SJ/A,SJG,SJG/A,SJP,SK,SMD,SMX2,SN,SN/A,SWA4,SWC4,SWC4/A,SX,SX/A,SXB,SXB/A,SXB7,SXB7/A,SXQ4,SXQ4/A,SXU,SXU/A,SX2,VA,VAG2,VAG2/A,VAW,VAW1,VA2,VA2/A,VD16,VH,VKX4,VMA4,VMT,VMT/A,VM2,VM2/A,VNG1,VNG1/A,VNT2,VNT2/A,VN17,VN17/A,VPX4,VPX4/A,VPX5,VPX7,VPX7/A,VSD,VSD/A,VSD3,VSD3/A,VSD7,VSD7/A,VSH7,VS3,VS37,VS37/A,VWA,VWA2,VWA2/A,VWN2,VWN2/A,VW12,VW12/A,VW22,VX,VX/A,VXB,VXB/A,VXB2,VXB6,VXB7,VXB7/A,VXG,VXQ4,VXQ4/A,VXTB,VXT1,VXT1/A,VXU,VXU/A,VXU1,VXU1/A,VX26,WMT8,WMT8/A
6	31100-ZE2-812	FLYWHEEL COMP. (LAMP)	1	-	-	-----	LT,LT/A,LW,LW/A,QHR,QHR/A,QP,QP/A,RSC2,RSC2/A,SMC4,SMC4/A,SW,VMX2

Ref. No.	Part No.	Description	Reqd. QTY			Serial No.	Parts catalogue code
			(1)	(2)	(3)		
7	31100-ZE2-822	FLYWHEEL COMP. (STARTER MOTOR)	1	-	-		LHE, LHE/A, LTJ, LWD, LX, LXE, LXE/A, LXQ4, LXZ, LX16, L1, PA, PA2, PX, PX26, QA, QAE, QAE2, QAE6, QAE8, QAE8/A, QHE, QHE4, QHE4/A, QXE, QXE/A, QXEB, QXE4, QXE4/A, QXE6, QXE6/A, QXE8, QXE8/A, RHE, RHE4, RHE4/A, SHE, SHEZ, SWE, SXE, SXE/A, SXEB, SXEB/A, SXE4, SXE4/A, SXE8, SXE8/A, VEB6, VME4, VMS2, VPE4, VPE4/A, VPE5, VPE7, VPE7/A, VWT4, VWT4/A, VXE, VXEB, VXEB/A, VXE4, VXE4/A, VXE6, VXE6/A, VXE7, VXE7/A, WMA4, WXE8, WXE8/A
8	90201-ZE3-790	NUT, SPECIAL, 16MM	-	(1)	-	1180427	ESS, HA, HAQ, HA2, HEA, HEA2, HH, HX, HXQ4, HX26, LH, LHE, LHQ4, LJ, LJG, LSS, LTJ, LW, LWD, LX, LXE, LXQ4, LXZ, LX16, L1, PA, PA2, PX, PX26, QA, QAE, QAE2, QAE6, QAE8, QAE8/A, QHE, QHE4, QHE4/A, QXE, QXE/A, QXEB, QXE4, QXE4/A, QXE6, QXE6/A, QXE8, QXE8/A, QSC, QSC9, QT, QX, QXB, QXC, QXC4, QXC6, QXC9, QXE, QXE/A, QXEB, QXE4, QXE4/A, QXQ4, QX26, Q1, Q2, RA, RA2, RD, RH, RHE, RHE4, RHQ4, RH26, RSC2, RX, RXQ4, R1, SD, SE, SH, SHE, SHEZ, SHQ4, SJ, SJG, SJP, SK, SMC4, SME1, SME6, SN, SW, SWE, SX, SXB, SXE, SXEB, SXE4, SXQ4, SX2, S1, VA, VAW, VAW1, VA2, VDE, VD16, VEB6, VH, VNG1, VSD, VSD3, VWA, VWA2, VWN2, VW12, VW22, VX, VXB, VXB2, VXB6, VXE, VXEB, VXE4, VXG, VXQ4, VXU, VX26, V1, W1
	90201-ZE3-V00	-	-	1	1000009	VXP, VXQP
			1	1	1		ESS/A, ES1, ES1/A, ES3, ES3/A, HAP, HAP/A, HA2/A, HEA2/A, HEA8, HEA8/A, HX/A, HXQ4/A, HX26/A, HX8, HX8/A, LH/A, LHB1, LHB3, LHB5, LHE/A, LJ/A, LJC, LJC/A, LJG/A, LT, LT/A, LW/A, LWD1, LWD1/A, LX/A, LXE/A, LXE8, LXE8/A, LXQ4/A, LXU, LXU/A, L1/A, PAE2, PAE2/A, PA2/A, PX/A, PXE8, PXE8/A, PXU, PXU/A, PX26/A, QAB1, QAB3, QAB3/A, QAE2/A, QAE6/A, QAG, QAG/A, QAG2, QAG2/A, QAAQ4/A, QAR2/A, QAW, QAW/A, QA2/A, QD/A, QE/A, QH/A, QHB5, QHE4/A, QHP1, QHP1/A, QHQ4/A, QHR, QHR/A, QHR4, QHR4/A, QHZ, QHZ/A, QH26/A, QKE3, QKE3/A, QKE4, QL2, QME2/A, QMH, QMH/A, QP/A, QSC9/A, QSE, QSE/A, QSE2, QSE8, QSE8/A, QT/A, QWA2, QWA4, QWA4/A, QWH2, QWH2/A, QX/A, QXB/A, QXB6, QXB6/A, QXB7, QXB7/A, QXC4/A, QXC6/A, QXC9/A, QXE/A, QXE4/A, QXE6/A, QXE8, QXE8/A, QXQ4/A, QXU, QXU/A, QX26/A, Q1/A, RA2/A, RD/A, RHE4/A, RHQ4/A, RH26/A, RSC2/A, RSS, RSS/A, RX/A, RXP, RXP/A, RXQ4/A, RXU, RXU/A, R1/A, SD/A, SE/A, SH/A, SHQ4/A, SJ/A, SJG/A, SKE1, SMC4/A, SMD, SME1/A, SME6/A, SMX2, SN/A, SWA4, SWC4, SWC4/A, SX/A, SXB/A, SXB7, SXB7/A, SXE/A, SXEB/A, SXE4/A, SXE8, SXE8/A, SXQ4/A, SXU, SXU/A, S1/A, VAG2, VAG2/A, VA2/A, VDE2, VDE2/A, VKB2, VKB2/A, VKE4, VKX4, VMA4, VME2, VME2/A, VME4, VMS2, VMT, VMT/A, VMX2, VM2, VM2/A, VNG1/A, VNT2, VNT2/A, VN17, VN17/A, VPE4, VPE4/A, VPE5, VPE7, VPE7/A, VPX4, VPX4/A, VPX5, VPX7, VPX7/A, VSD/A, VSD3/A, VSD7, VSD7/A, VSH7, VS3, VS37, VS37/A, VWA2/A, VWN2/A, VWT4, VWT4/A, VW12/A, VX/A, VXB/A, VXB7, VXB7/A, VXEB/A, VXE4/A, VXE6, VXE6/A, VXE7, VXE7/A, VXP/A, VXQ4/A, VXTB, VXT1, VXT1/A, VXU/A, VXU1, VXU1/A, WMA4, WMT8, WMT8/A, WXE8, WXE8/A, W1/A
			1	1	-	1180428	ESS, HA, HAQ, HA2, HEA, HEA2, HH, HX, HXQ4, HX26, LH, LHE, LHQ4, LJ, LJG, LSS, LTJ, LW, LWD, LX, LXE, LXQ4, LXZ, LX16, L1, PA, PA2, PX, PX26, QA, QAE, QAE2, QAE6, QAE8, QAE8/A, QHE, QHE4, QHE4/A, QXE, QXE/A, QXEB, QXE4, QXE4/A, QXE6, QXE6/A, QXE8, QXE8/A, QSC, QSC9, QT, QX, QXB, QXC, QXC4, QXC6, QXC9, QXE, QXE/A, QXEB, QXE4, QXE4/A, QXQ4, QX26, Q1, Q2, RA, RA2, RD, RH, RHE, RHE4, RHQ4, RH26, RSC2, RX, RXQ4, R1, SD, SE, SH, SHE, SHEZ, SHQ4, SJ, SJG, SJP, SK, SMC4, SME1, SME6, SN, SW, SWE, SX, SXB, SXE, SXEB, SXE4, SXQ4, SX2, S1, VA, VAW, VAW1, VA2, VDE, VD16, VEB6, VH, VNG1, VSD, VSD3, VWA, VWA2, VWN2, VW12, VW22, VX, VXB, VXB2, VXB6, VXE, VXEB, VXE4, VXG, VXQ4, VXU, VX26, V1, W1
9	90741-ZE2-000	KEY, SPECIAL WOODRUFF, 25X18	-	-	1	1000010	VXP, VXQP
10	31100-ZE2-W01	FLYWHEEL COMP. (18A)	1	-	-		QAR2, QAR2/A, QL2
			-	(1)	-		
11	31100-ZE2-W11	FLYWHEEL COMP. (SEL-18A)	-	(1)	-		
	31100-ZE2-832	FLYWHEEL COMP. (4POLE)	1	-	-		HEA, HEA2, HEA2/A, HEA8, HEA8/A, LWD1, LWD1/A, PAE2, PAE2/A, QAE, QAE2, QAE2/A, QAE6, QAE6/A, QAG, QAG/A, QHR4, QHR4/A, QKE3, QKE3/A, QKE4, QME2, QME2/A, QSC, QSC9, QSC9/A, QSE, QSE/A, QSE2, QSE8, QSE8/A, QXB6, QXB6/A, RSS, RSS/A, SKE1, SME1, SME1/A, SME6, SME6/A, VDE, VDE2, VDE2/A, VKB2, VKB2/A, VKE4, VME2, VME2/A
			-	(1)	-		



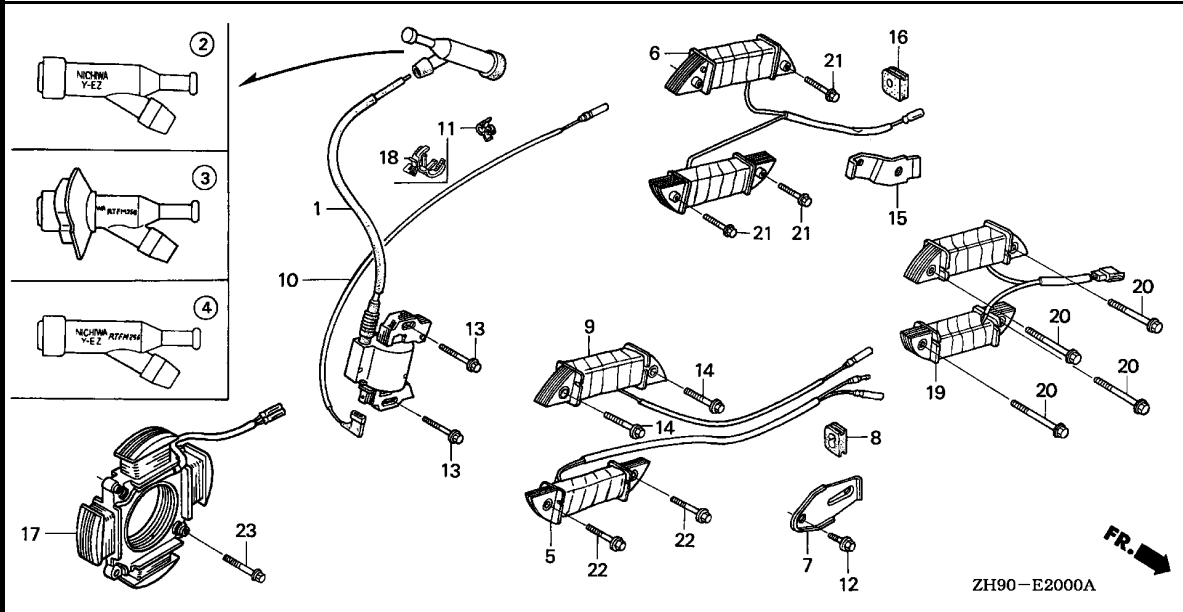

Ref. No.	L.O.N.	(Relative ref. Number) Description	F.R.T.
1	6141A5	COIL, IGNITION(ONE) (3,4)	0.3
2	6141B8	TERMINAL, HIGH TENSION (5)	0.1
6	6141A6	COIL, LAMP (17,19)	0.3
9	6131C3	COIL, CHARGE	0.3
10	6111B3	CORD, STOP SWITCH	0.3



Ref. No.	Part No.	Description	Reqd. QTY			Serial No.	Parts catalogue code
			(1)	(2)	(3)		
1	30500-ZF6-W02	COIL ASSY., IGNITION	1	(1)	1		
2	30600-ZE1-013	TERMINAL ASSY., HIGH TENSION (NICHIWA Y-EZ)	1	-	-	ES1,ES1/A,ES3,ES3/A,LJ,LJ/A,LJC,LJC/A,LJG,LJG/A,LSS,LT,LT/A,LTJ,LWD1,LWD1/A,QD,QD/A,QT,QT/A,RD,RD/A,SD,SD/A,SJ,SJ/A,SJG,SJG/A,SJP,SK,SN,SN/A,VS3	
3	30700-ZB7-013	CAP ASSY., NOISE SUPPRESSOR (NICHIWA Y-EZ RTFM256)	1	(1)	-	ESS,ESS/A	

Ref. No.	Part No.	Description	Reqd. QTY			Serial No.	Parts catalogue code
			(1)	(2)	(3)		
4	30700-ZE1-013	CAP ASSY., NOISE SUPPRESSOR (NICHIIWA Y-EZ RTFM256)	1	-	-	-----	HA,HAQ,HA2,HA2/A,HEA,HEA2,HEA2/A,HEA8,HEA8/A,HH,HX,HX/A,HXQ4 HXQ4/A,HX26,HX26/A,HX8,HX8/A,LH,LH/A,LHB1,LHB3,LHB5,LHE,LHE/A LHQ4,LW,LW/A,LWD,LX,LX/A,LXE,LXE/A,LXE8,LXE8/A,LXQ4,LXQ4/A,LXU LXU/A,LXZ,LX16,PA,PAE2,PAE2/A,PA2,PA2/A,PX,PX/A,PXE8,PXE8/A,PXU PXU/A,PX26,PX26/A,QA,QAB1,QAB3,QAB3/A,QAE,QAE2,QAE2/A,QAE6,QAE6/A QAG,QAG/A,QAG2,QAG2/A,QAQ,QAQ4,QAQ4/A,QAR2,QAR2/A,QAW,QAW/A,QA2 QA2/A,QE,QE/A,QH,QH/A,QHB5,QHC,QHE,QHE4,QHE4/A,QHP1,QHP1/A,QHQ4 QHQ4/A,QHR,QHR/A,QHR4,QHR4/A,QHZ,QHZ/A,QH26,QH26/A,QKE3,QKE3/A QKE4,QL2,QME2,QME2/A,QMH,QMH/A,QP,QP/A,QSC,QSC9,QSC9/A,QSE,QSE/A QSE2,QSE8,QSE8/A,QWA2,QWA4,QWA4/A,QWH2,QWH2/A,QX,QX/A,QXB,QXB/A QXB6,QXB6/A,QXB7,QXB7/A,QXC,QXC4,QXC4/A,QXC6,QXC6/A,QXC9,QXC9/A QXE,QXE/A,QXEB,QXE4,QXE4/A,QXE6,QXE6/A,QXE8,QXE8/A,QXQ4,QXQ4/A QXU,QXU/A,QX26,QX26/A,RA,RA2,RA2/A,RH,RHE,RHE4,RHE4/A,RHQ4,RHQ4/A RH26,RH26/A,RSC2,RSC2/A,RSS,RSS/A,RX,RX/A,RXQ4,RXQ4/A,RXU,RXU/A SE,SE/A,SH,SH/A,SHE,SHEZ,SHQ4,SHQ4/A,SKE1,SMC4,SMC4/A,SMD,SME1 SME1/A,SME6,SME6/A,SMX2,SW,SWA4,SWC4,SWC4/A,SWE,SX,SX/A,SBX,SBX/A SBX7,SBX7/A,SXE,SXE/A,SXEB,SXEB/A,SXE4,SXE4/A,SXE8,SXE8/A, SXQ4 SXQ4/A,SXU,SXU/A,SX2,VA,VAG2,VAG2/A,VAW,VAW1,VA2,VA2/A,VDE,VDE2 VDE2/A,VD16,VEB6,VH,VKB2,VKB2/A,VMA4,VME2,VME2/A,VME4,VMS2,VMT VMT/A,VMX2,VM2,VM2/A,VNG1,VNG1/A,VNT2,VNT2/A,VN17,VN17/A,VSD VSD/A,VSD7,VSD7/A,VSH7,VWA,VWA2,VWA2/A,VWN2,VWN2/A,VWT4,VWT4/A VW12,VW12/A,VW22,VX,VX/A,VXB,VXB/A,VXB2,VXB6,VXB7,VXB7/A,VXE,VXEB VXEB/A,VXE4,VXE4/A,VXE6,VXE6/A,VXE7,VXE7/A,VXG,VXQ4,VXQ4/A,VXTB VXT1,VXT1/A,VXU,VXU/A,VXU1,VXU1/A,VX26,WMA4,WMT8,WMT8/A,WXE8 WXE8/A
	30700-ZF5-013	CAP ASSY., NOISE SUPPRESSOR	1	(1)	1	-----	VKE4,VKX4,VPE4,VPE4/A,VPE5,VPE7,VPE7/A,VPX4,VPX4/A,VPX5,VPX7 VPX7/A,VSD3,VSD3/A,VS37,VS37/A
5	31510-ZE1-811	COIL ASSY., LAMP (12V/25W)	1	-	-	-----	RSS,RSS/A,VMX2
	31510-ZE1-831	COIL ASSY., LAMP (6V/25W)	-	(1)	-	-----	
	31510-ZE2-H91	COIL ASSY., LAMP (12V/25W)	1	-	-	-----	VMS2
	31510-ZE3-003	1	-	-	-----	LTJ,RSS,RSS/A
6	31510-ZE2-811	COIL ASSY., LAMP (12V/50W)	1	-	-	-----	LT,LT/A,LW,LW/A,QHR,QHR/A,QP,QP/A,RSC2,RSC2/A,SMC4,SMC4/A,SW
			-	(1)	-	-----	
7	31511-ZE2-000	CLAMPER, CORD	1	-	-	-----	HEA,HEA2,HEA2/A,HEA8,HEA8/A,LHE,LHE/A,LT,LT/A,LTJ,LW,LW/A,LWD LWD1,LWD1/A,LXE,LXE/A,LXE8,LXE8/A,PAE2,PAE2/A,PXE8,PXE8/A,QAE QAE2,QAE2/A,QAE6,QAE6/A,QAG,QAG/A,QHE,QHE4,QHE4/A,QHR,QHR/A,QHR4 QHR4/A,QKE3,QKE3/A,QKE4,QME2,QME2/A,QP,QP/A,QSC,QSC9,QSC9/A,QSE QSE/A,QSE2,QSE8,QSE8/A,QXB6,QXB6/A,QXE,QXE/A,QXEB,QXE4,QXE4/A QXE6,QXE6/A,QXE8,QXE8/A,RHE,RHE4,RHE4/A,RSC2,RSC2/A,RSS,RSS/A,SHE SHEZ,SKE1,SMC4,SMC4/A,SME1,SME1/A,SME6,SME6/A,SW,SWE,SXE,SXE/A SXEB,SXEB/A,SXE4,SXE4/A,SXE8,SXE8/A,VDE,VDE2,VDE2/A,VEB6,VKB2 VKB2/A,VKE4,VME2,VME2/A,VME4,VMS2,VMX2,VPE4,VPE4/A,VPE5,VPE7 VPE7/A,VXE,VXEB,VXEB/A,VXE4,VXE4/A,VXE6,VXE6/A,VXE7,VXE7/A,WMA4 WXE8,WXE8/A
			-	(1)	-	-----	



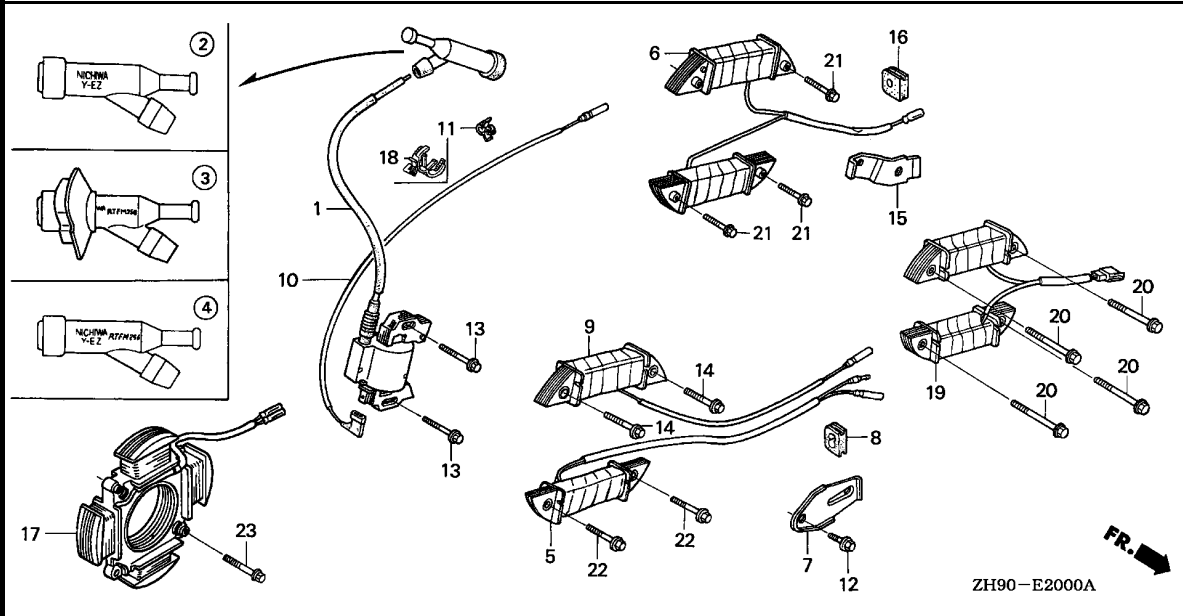

ZH90-E2000A

Ref. No.	Part No.	Description	Reqd. QTY			Serial No.	Parts catalogue code
			(1)	(2)	(3)		
8	31512-ZE2-000	GROMMET, CORD	1	-	-	-----	ESS,ESS/A,ES1,ES1/A,ES3,ES3/A,HA,HAQ,HA2,HA2/A,HEA,HEA2,HEA2/A,HEA8,HEA8/A,HH,HX,HX/A,HXQ4,HXQ4/A,HX26,HX26/A,HX8,HX8/A,LH,LH/A,LHB1,LHB3,LHB5,LHE,LHE/A,LHQ4,LJ,LJ/A,LJC,LJC/A,LJG,LJG/A,LSS,LT,LT/A,LTJ,LW,LW/A,LWD,LWD1,LWD1/A,LX,LX/A,LXE,LXE/A,LXE8,LXE8/A,LXQ4,LXQ4/A,LXU,LXU/A,LXZ,LX16,PA,PAE2,PAE2/A,PA2,PA2/A,PX,PX/A,PXE8,PXE8/A,PXU,PXU/A,PX26,PX26/A,QA,QAB1,QAB3,QAB3/A,QAE,QAE2,QAE2/A,QAE6,QAE6/A,QAG,QAG/A,QAG2,QAG2/A,QAQ,QAQ4,QAQ4/A,QAR2,QAR2/A,QAW,QAW/A,QA2,QA2/A,QD,QD/A,QE,QE/A,QH,QH/A,QHB5,QHC,QHE,QHE4,QHE4/A,QHP1,QHP1/A,QHQ4,QHQ4/A,QHR,QHR/A,QHR4,QHR4/A,QHZ,QHZ/A,QH26,QH26/A,QKE3,QKE3/A,QKE4,QL2,QME2,QME2/A,QMH,QMH/A,QP,QP/A,QSC,QSC9,QSC9/A,QSE,QSE/A,QSE2,QSE8,QSE8/A,QT,QT/A,QWA2,QWA4,QWA4/A,QWH2,QWH2/A,QX,QX/A,QXB,QXB/A,QXB6,QXB6/A,QXB7,QXB7/A,QXC,QXC4,QXC4/A,QXC6,QXC6/A,QXC9,QXC9/A,QXE,QXE/A,QXEB,QXE4,QXE4/A,QXE6,QXE6/A,QXE8,QXE8/A,QXQ4,QXQ4/A,QXU,QXU/A,QX26,QX26/A,RA,RA2,RA2/A,RD,RD/A,RH,RHE,RHE4,RHE4/A,RHQ4,RHQ4/A,RH26,RH26/A,RSC2,RSC2/A,RSS,RSS/A,RX,RX/A,RXQ4,RXQ4/A,RXU,RXU/A,SD,SD/A,SE,SE/A,SH,SH/A,SHE,SHEZ,SHQ4,SHQ4/A,SJ,SJ/A,SJG,SJG/A,SJP,SK,SKE1,SMD,SME1,SME1/A,SME6,SME6/A,SMX2,SN,SN/A,SW,SWA4,SWC4,SWC4/A,SWE,SX,SX/A,SXB,SXB/A,SXB7,SXB7/A,SXE,SXE/A,SXEB,SXEB/A,SXE4,SXE4/A,SXE8,SXE8/A,SXQ4,SXQ4/A,SXU,SXU/A,SX2,VA,VAG2,VAG2/A,VAW,VAW1,VA2,VA2/A,VDE,VDE2,VDE2/A,VD16,VEB6,VH,VKB2,VKB2/A,VKE4,VKX4,VMA4,VME2,VME2/A,VME4,VMS2,VMT,VMT/A,VMX2,VM2,VM2/A,VNG1,VNG1/A,VNT2,VNT2/A,VN17,VN17/A,VPE4,VPE4/A,VPE5,VPE7,VPE7/A,VPX4,VPX4/A,VPX5,VPX7,VPX7/A,VSD,VSD/A,VSD3,VSD3/A,VSD7,VSD7/A,VSH7,VS3,VS37,VS37/A,VWA,VWA2,VWA2/A,VWN2,VWN2/A,VWT4,VWT4/A,VW12,VW12/A,VW22,VX,VX/A,VXB,VXB/A,VXB2,VXB6,VXB7,VXB7/A,VXE,VXE8,VXE8/A,VXE4,VXE4/A,VXE6,VXE6/A,VXE7,VXE7/A,VXG,VXQ4,VXQ4/A,VXTB,VXT1,VXT1/A,VXU,VXU/A,VXU1,VXU1/A,VX26,WMA4,WMT8,WMT8/A,WXE8,WXE8/A
				(1)	1		

2

Ref. No.	Part No.	Description	Reqd. QTY			Serial No.	Parts catalogue code	
			(1)	(2)	(3)			
9	31630-ZE1-003	COIL ASSY., CHARGE (1A)	1	-	-	-----	LHE, LHE/A, LTJ, LWD, LXE, LXE/A, LXE8, LXE8/A, PXE8, PXE8/A, QHE, QHE4, QHE4/A, QXE, QXE/A, QXEB, QXE4, QXE4/A, QXE6, QXE6/A, QXE8, QXE8/A, RHE, RHE4, RHE4/A, SHE, SHEZ, SWE, SXE, SXE/A, SXEB, SXEB/A, SXE4, SXE4/A, SXE8, SXE8/A, VEB6, VME4, VPE4, VPE4/A, VPE5, VPE7, VPE7/A, VXE, VXEB, VXEB/A, VXE4, VXE4/A, VXE6, VXE6/A, VXE7, VXE7/A, WMA4, WXE8, WXE8/A	
	31630-ZE2-841	COIL ASSY., CHARGE (3A)	1	(1)	-	-----	HEA, HEA2, HEA2/A, HEA8, HEA8/A, L1, L1/A, PAE2, PAE2/A, QAE, QAE2, QAE2/A, QAE6, QAE6/A, Q1, Q1/A, Q2, R1, R1/A, VDE, VDE2, VDE2/A, VKB2, VKB2/A, VKE4, VME2, VME2/A, VMS2, V1, W1, W1/A	
10	36101-ZE1-010	CORD, STOP SWITCH (370MM) ...	1	-	-	-----	ESS, ESS/A, ES1, ES1/A, HA, HAQ, HA2, HA2/A, HEA, HEA2, HEA2/A, HEA8, HEA8/A, HH, HX, HX/A, HXQ4, HXQ4/A, HX26, HX26/A, HX8, HX8/A, LH, LH/A, LHB1, LHB3, LHB5, LHE, LHE/A, LHQ4, LJ, LJ/A, LJC, LJC/A, LJG, LJG/A, LSS, LT, LT/A, LTJ, LW, LW/A, LWD, LWD1, LWD1/A, LX, LX/A, LXE, LXE/A, LXEB, LXEB/A, LXQ4, LXQ4/A, LXU, LXU/A, LXZ, LX16, PA, PAE2, PAE2/A, PA2, PA2/A, PX, PX/A, PXE8, PXE8/A, PXU, PXU/A, PX26, PX26/A, QA, QAB1, QAB3, QAB3/A, QAE, QAE2, QAE2/A, QAE6, QAE6/A, QAG, QAG/A, QAG2, QAG2/A, QAQ, QAQ4, QAQ4/A, QAR2, QAR2/A, QAW, QAW/A, QA2, QA2/A, QD, QD/A, QE, QE/A, QH, QH/A, QHB5, QHC, QHE, QHE4, QHE4/A, QHP1, QHP1/A, QHQ4, QHQ4/A, QHR, QHR/A, QHR4, QHR4/A, QHZ, QHZ/A, QH26, QH26/A, QKE3, QKE3/A, QKE4, QL2, QME2, QME2/A, QMH, QMH/A, QP, QP/A, QSC, QSC9, QSC9/A, QSE, QSE/A, QSE2, QSE8, QSE8/A, QT, QT/A, QWA2, QWA4, QWA4/A, QWH2, QWH2/A, QX, QX/A, QXB, QXB/A, QXB6, QXB6/A, QXB7, QXB7/A, QXC, QXC4, QXC4/A, QXC6, QXC6/A, QXC9, QXC9/A, QXE, QXE/A, QXEB, QXE4, QXE4/A, QXE6, QXE6/A, QXE8, QXE8/A, QXQ4, QXQ4/A, QXU, QXU/A, QX26, QX26/A, RA, RA2, RA2/A, RD, RD/A, RH, RHE, RHE4, RHE4/A, RHQ4, RHQ4/A, RH26, RH26/A, RSC2, RSC2/A, RSS, RSS/A, RX, RX/A, RXQ4, RXQ4/A, RXU, RXU/A, SD, SD/A, SE, SE/A, SH, SH/A, SHE, SHEZ, SHQ4, SHQ4/A, SJ, SJ/A, SJG, SJG/A, SJP, SK, SKE1, SMC4, SMC4/A, SMD, SME1, SME1/A, SME6, SME6/A, SMX2, SN, SN/A, SW, SWA4, SWC4, SWC4/A, SWE, SX, SX/A, SXB, SXB/A, SXB7, SXB7/A, SXE, SXE/A, SXEB, SXEB/A, SXE4, SXE4/A, SXE8, SXE8/A, SXQ4, SXQ4/A, SXU, SXU/A, SX2, VA, VAG2, VAG2/A, VAW, VAW1, VA2, VA2/A, VDE, VDE2, VDE2/A, VD16, VEB6, VH, VKB2, VKB2/A, VKE4, VKX4, VMA4, VME2, VME2/A, VME4, VMS2, VMX2, VM2, VM2/A, VNG1, VNG1/A, VNT2, VNT2/A, VN17, VN17/A, VPE4, VPE4/A, VPE5, VPE7, VPE7/A, VPX4, VPX4/A, VPX5, VPX7, VPX7/A, VSD, VSD/A, VSD3, VSD3/A, VSD7, VSD7/A, VSH7, VS37, VS37/A, VWA, VWA2, VWA2/A, VWN2, VWN2/A, VWT4, VWT4/A, VW12, VW12/A, VW22, VX, VX/A, VXB, VXB/A, VXB2, VXB6, VXB7, VXB7/A, VXE, VXEB, VXEB/A, VXE4, VXE4/A, VXE6, VXE6/A, VXE7, VXE7/A, VXG, VXQ4, VXQ4/A, VXTB, VXT1, VXT1/A, VXU, VXU/A, VXU1, VXU1/A, VX26, WMA4, WMT8, WMT8/A, WXE8, WXE8/A	
	36101-ZE2-701	CORD, STOP SWITCH (430MM) ...	1	-	-	-----	ES3, ES3/A, VMT, VMT/A, VS3	
11	36103-ZE1-000	HOLDER, STOP SWITCH CORD	1	1	-	-----	ESS, ESS/A, ES3, ES3/A, HEA, HEA2, HEA2/A, HH, LH, LH/A, LHB1, LHB3, LHB5, LHQ4, LJ, LJ/A, LJG, LJG/A, LSS, LT, LT/A, LTJ, LW, LW/A, LWD, LXE, LXE/A, L1, L1/A, QD, QD/A, QE, QE/A, QH, QH/A, QHB5, QHC, QHP1, QHP1/A, QHQ4, QHQ4/A, QHR, QHR/A, QHZ, QHZ/A, QH26, QH26/A, QMH, QMH/A, QP, QP/A, QT, QT/A, Q1, Q1/A, RD, RD/A, RH, RHQ4, RHQ4/A, RH26, RH26/A, RSS, RSS/A, R1, R1/A, SD, SD/A, SE, SE/A, SH, SH/A, SHQ4, SHQ4/A, SJ, SJ/A, SJG, SJG/A, SK, SN, SN/A, SW, S1, S1/A, VH, VMT, VMT/A, VS3, V1, W1, W1/A	
			1	-	-	1584262	-----	RSS
			2	(1)	-	-----	-----	HA, PA, QA, QAE, QXC, Q2, RA, VA, VAW, VDE



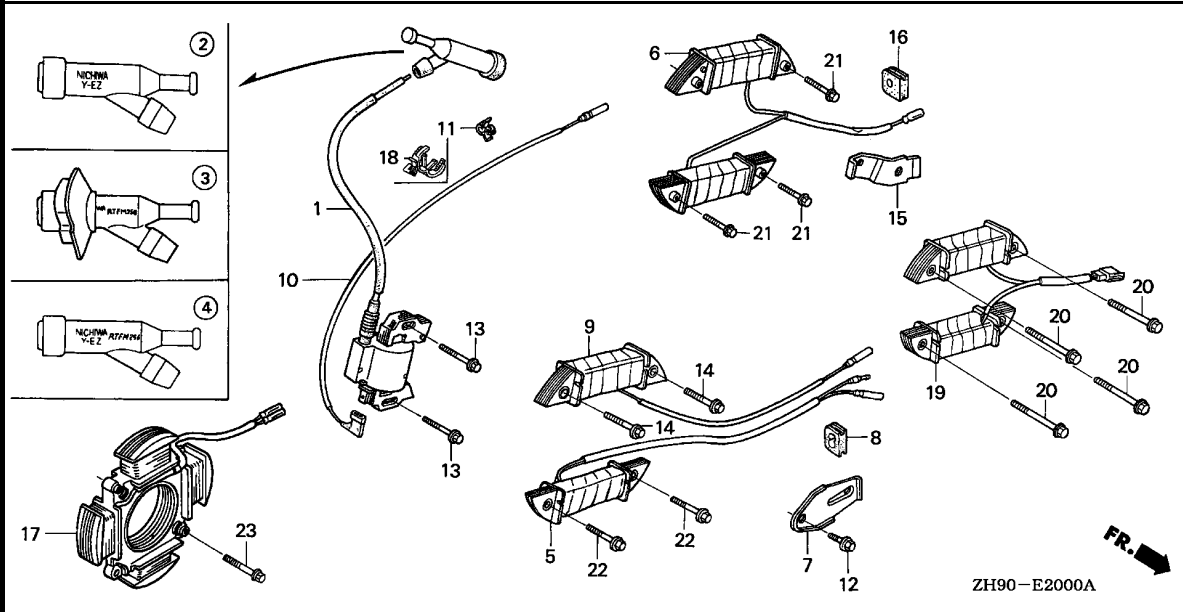

Ref. No.	Part No.	Description	Reqd. QTY			Serial No.	Parts catalogue code
			(1)	(2)	(3)		
12	90013-883-000	BOLT, FLANGE, 6X12(CT200) ...	1	-	-	-----	HEA, HEA2, HEA2/A, HEA8, HEA8/A, LHE, LHE/A, LT, LT/A, LTJ, LW, LW/A, LWD, LWD1, LWD1/A, LXE, LXE/A, LXE8, LXE8/A, PAE2, PAE2/A, PXE8, PXE8/A, QAE, QAE2, QAE2/A, QAE6, QAE6/A, QAG, QAG/A, QHE, QHE4, QHE4/A, QHR, QHR/A, QHR4, QHR4/A, QKE3, QKE3/A, QKE4, QME2, QME2/A, QP, QP/A, QSC, QSC9, QSC9/A, QSE, QSE/A, QSE2, QSE8, QSE8/A, QXB6, QXB6/A, QXE, QXE/A, QXEB, QXE4, QXE4/A, QXE6, QXE6/A, QXE8, QXE8/A, RHE, RHE4, RHE4/A, RSC2, RSC2/A, RSS, RSS/A, SHE, SHEZ, SHEZ, SMC4, SMC4/A, SME1, SME1/A, SME6, SME6/A, SW, SWE, SXE, SXE/A, SXEB, SXEB/A, SXE4, SXE4/A, SXE8, SXE8/A, VDE, VDE2, VDE2/A, VEB6, VKB2, VKB2/A, VKE4, VME2, VME2/A, VME4, VMS2, VMX2, VPE4, VPE4/A, VPE5, VPE7, VPE7/A, VXE, VXEB, VXEB/A, VXE4, VXE4/A, VXE6, VXE6/A, VXE7, VXE7/A, WMA4, WXE8, WXE8/A
13	90015-883-000	BOLT, FLANGE, 6X28	-	(1)	-	-----	
14	90015-883-000	BOLT, FLANGE, 6X28	2	(2)	2	-----	LHE, LHE/A, LTJ, LWD, LXE, LXE/A, LXE8, LXE8/A, PXE8, PXE8/A, QHE, QHE4, QHE4/A, QXE, QXE/A, QXEB, QXE4, QXE4/A, QXE6, QXE6/A, QXE8, QXE8/A, RHE, RHE4, RHE4/A, SHE, SHEZ, SWE, SXE, SXE/A, SXEB, SXEB/A, SXE4, SXE4/A, SXE8, SXE8/A, VEB6, VME4, VPE4, VPE4/A, VPE5, VPE7, VPE7/A, VXE, VXEB, VXEB/A, VXE4, VXE4/A, VXE6, VXE6/A, VXE7, VXE7/A, WMA4, WXE8, WXE8/A
	90017-883-000	BOLT, FLANGE, 6X32	-	(2)	-	-----	HEA, HEA2, HEA2/A, HEA8, HEA8/A, PAE2, PAE2/A, QAE, QAE2, QAE2/A, QAE6, QAE6/A, VDE, VDE2, VDE2/A, VKB2, VKB2/A, VKE4, VME2, VME2/A, VMS2
15	31511-ZE2-W00	CLAMPER, CORD	1	-	-	-----	QAR2, QAR2/A, QL2
			-	(1)	-	1069840	Q2
			-	(1)	-	1120970	L1, Q1, R1, S1, V1, W1
16	31512-ZG3-000	GROMMET, CORD	-	(1)	-	1120970	L1, Q1, Q2, R1, S1, V1, W1
17	31630-ZE2-W01	COIL ASSY., CHARGE (12V/18A)	1	-	-	-----	QAR2, QAR2/A, QL2
			-	(1)	-	1120970	L1, Q1, R1, S1, V1, W1

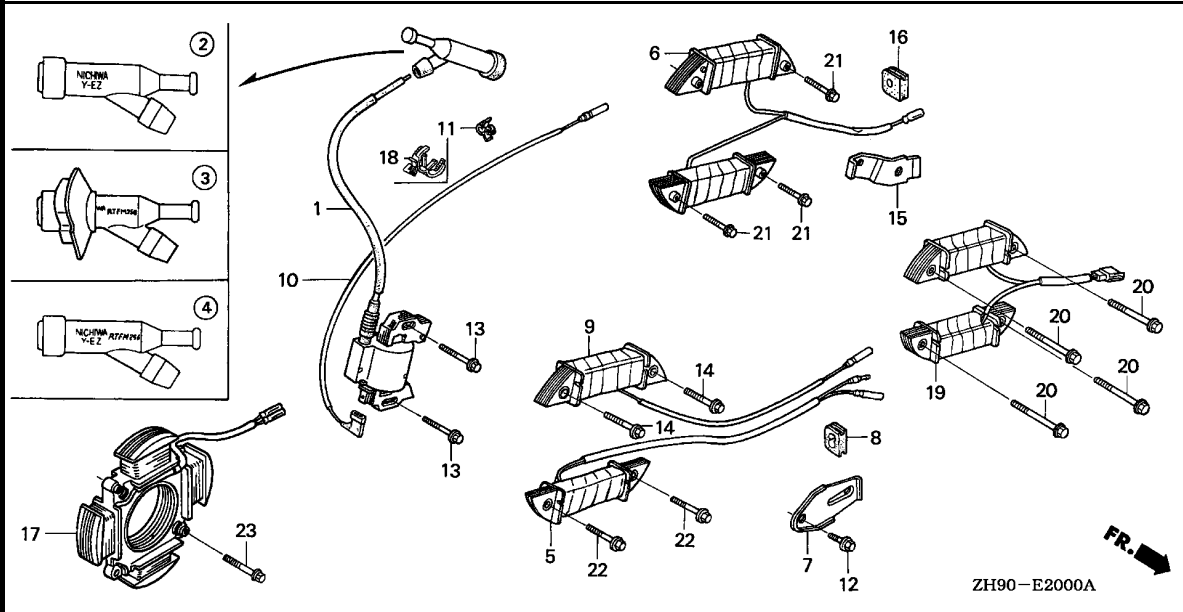

Ref. No.	Part No.	Description	Reqd. QTY			Serial No.	Parts catalogue code
			(1)	(2)	(3)		
18	90684-ZA0-601	CLIP, HARNESS	1	-	1		HAP, HAP/A, QAG, QAG/A, QAG2, QAG2/A, QAW, QAW/A, QL2, QWA2, QWA4, QWA4/A, QWH2, QWH2/A, QXB7, QXB7/A, SXB7, SXB7/A, VKX4, VMA4, VMX2, VM2, VM2/A, VNT2, VNT2/A, VN17, VN17/A, VPX7, VPX7/A, VSD7, VSD7/A, VSH7, VS37, VS37/A, VXB7, VXB7/A, VXQ4, VXQ4/A, VXT1, VXT1/A, VXU, VXU/A, VXU1, VXU1/A, WMT8, WMT8/A
19	31630-ZE2-861	COIL ASSY., CHARGE (10A)	1	-	-	1584261	RSS LWD1, LWD1/A, L1, L1/A, QAG, QAG/A, QHR4, QHR4/A, QKE3, QKE3/A, QKE4, QME2, QME2/A, QSC, QSC9, QSC9/A, QSE, QSE/A, QSE2, QSE8, QSE8/A, QXB6, QXB6/A, Q1, Q1/A, Q2, R1, R1/A, SKE1, SME1, SME1/A, SME6, SME6/A, V1, W1, W1/A
20	90017-883-000	BOLT, FLANGE, 6X32	4	(4)	-		LWD1, LWD1/A, L1, L1/A, QAG, QAG/A, QHR4, QHR4/A, QKE3, QKE3/A, QKE4, QME2, QME2/A, QSC, QSC9, QSC9/A, QSE, QSE/A, QSE2, QSE8, QSE8/A, QXB6, QXB6/A, Q1, Q1/A, Q2, R1, R1/A, SKE1, SME1, SME1/A, SME6, SME6/A, V1, W1, W1/A
21	90015-883-000	BOLT, FLANGE, 6X28	4	-	-		LT, LT/A, LW, LW/A, QHR, QHR/A, QP, QP/A, RSC2, RSC2/A, SMC4, SMC4/A, SW
22	90015-883-000	BOLT, FLANGE, 6X28	2	-	-		LTJ, RSS, RSS/A, VMS2, VMX2
23	90015-883-000 90017-883-000	BOLT, FLANGE, 6X28 BOLT, FLANGE, 6X32	- 4	(4) -	-	1120970	L1, Q1, R1, S1, V1, W1 QAR2, QAR2/A, QL2



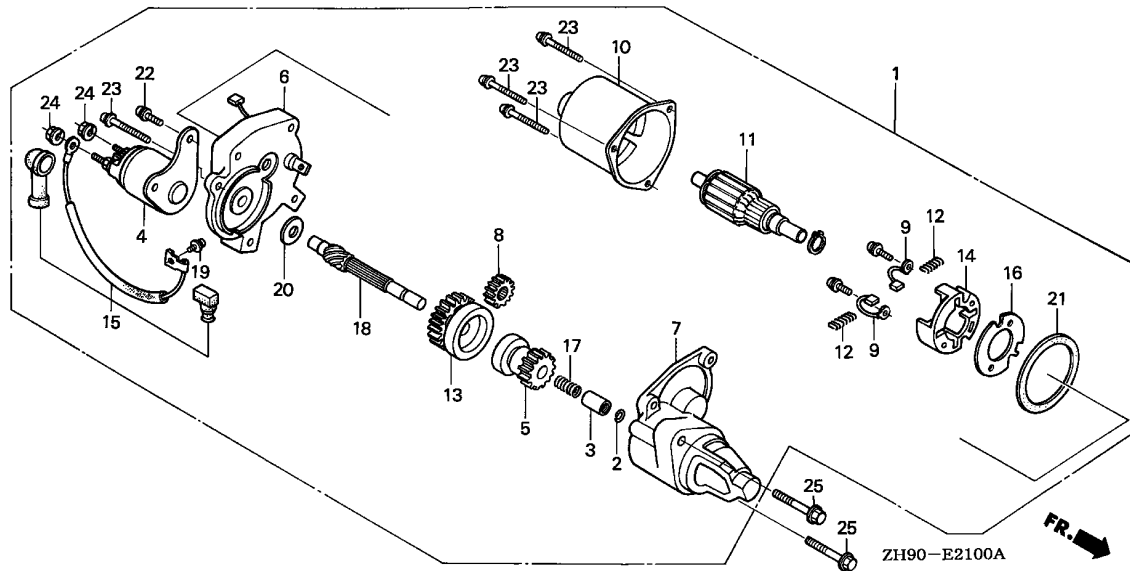

Ref. No.	L.O.N.	(Relative ref. Number) Description	F.R.T.
1	6121D5	MOTOR, STARTER	0.2
4	6121E5	CONTACTOR, STARTER	0.2
5	6121B0	CLUTCH, OVERRUNNING	0.4
6	6121C3	BRACKET, STARTER :CENTER	0.4
7	6121D2	BRACKET, STARTER :FRONT	0.3
9	6121A9	BRUSH, STARTER	0.4
11	6121A0	ARMATURE, STARTER	0.4
13	6121B5	GEAR, STARTER REDUCTION	0.4



Ref. No.	Part No.	Description	Reqd. QTY			Serial No.	Parts catalogue code	
			(1)	(2)	(3)			
1	31200-ZH9-003	MOTOR ASSY., STARTER	1	-	-	-----	HEA,HEA2,HEA2/A,HEA8,HEA8/A,LHE,LHE/A,LTJ,LWD,LWD1,LWD1/A,LXE,LXE/A,LXE8,LXE8/A,PAE2,PAE2/A,PXE8,PXE8/A,QAE,QAE2,QAE2/A,QAE6,QAE6/A,QHE,QHE4,QHE4/A,QHR4,QHR4/A,QKE3,QKE3/A,QKE4,QME2,QME2/A,QSC,QSC9,QSC9/A,QSE,QSE/A,QSE2,QSE8,QSE8/A,QXB6,QXB6/A,QXE,QXE/A,QXEB,QXE4,QXE4/A,QXE6,QXE6/A,QXE8,QXE8/A,RHE,RHE4,RHE4/A,SHE,SHEZ,SKE1,SME1,SME1/A,SWE,SXE,SXE/A,SXEB,SXEB/A,SXE4,SXE4/A,SXE8,SXE8/A,VDE,VDE2,VDE2/A,VEB6,VKB2,VKB2/A,VKE4,VME2,VME2/A,VME4,VMS2,VPE4,VPE4/A,VPE5,VPE7,VPE7/A,VWT4,VWT4/A,VXE,VXEB,VXEB/A,VXE4,VXE4/A,VXE6,VXE6/A,VXE7,VXE7/A,WMA4,WXE8,WXE8/A	
2	31201-ZA1-003	RING, SNAP	-	(1)	-	-----	HEA,HEA2,HEA2/A,HEA8,HEA8/A,LHE/A,LTJ,LWD1,LWD1/A,LXE,LXE/A,LXE8,LXE8/A,L1/A,PAE2,PAE2/A,PXE8,PXE8/A,QAE,QAE2/A,QAE6,QAE6/A,QHE4,QHE4/A,QHR4,QHR4/A,QKE3,QKE3/A,QKE4,QME2,QME2/A,QSC,QSC9,QSC9/A,QSE,QSE/A,QSE2,QSE8,QSE8/A,QXB6,QXB6/A,QXE/A,QXE4/A,QXE6,QXE6/A,QXE8,QXE8/A,Q1/A,RHE4,RHE4/A,R1/A,SKE1,SME1,SME1/A,SXE/A,SXEB/A,SXE4,SXE4/A,SXE8,SXE8/A,S1/A,VDE,VDE2,VDE2/A,VEB6,VKB2,VKB2/A,VKE4,VME2,VME2/A,VME4,VMS2,VPE4,VPE4/A,VPE5,VPE7,VPE7/A,VWT4,VWT4/A,VXEB/A,VXE4,VXE4/A,VXE6,VXE6/A,VXE7,VXE7/A,WMA4,WXE8,WXE8/A,W1/A	
			1	(1)	-	1065305	-----	LHE,LWD,L1,QAE2,QHE,QXE,QXEB,Q1,Q2,RHE,R1,SHE,SHEZ,SWE,SXE,SXEB,S1,VXE,VXEB,V1,W1

Ref. No.	Part No.	Description	Reqd. QTY			Serial No.	Parts catalogue code
			(1)	(2)	(3)		
3	31202-ZA1-003	COLLAR, CLUTCH STOP	1	(1)	-		HEA,HEA2,HEA2/A,HEA8,HEA8/A,LHE/A,LTJ,LWD1,LWD1/A,LXE,LXE/A,LXE8,LXE8/A,L1/A,PAE2,PAE2/A,PXE8,PXE8/A,QAE,QAE2/A,QAE6,QAE6/A,QHE4,QHE4/A,QHR4,QHR4/A,QKE3,QKE3/A,QKE4,QME2,QME2/A,QSC,QSC9,QSC9/A,QSE,QSE/A,QSE2,QSE8,QSE8/A,QXB6,QXB6/A,QXE/A,QXE4,QXE4/A,QXE6,QXE6/A,QXE8,QXE8/A,Q1/A,RHE4,RHE4/A,R1/A,SKE1,SME1,SME1/A,SXE/A,SXE8/A,SXE4,SXE4/A,SXE8,SXE8/A,S1/A,VDE,VDE2,VDE2/A,VEB6,VKB2,VKB2/A,VKE4,VME2,VME2/A,VME4,VMS2,VPE4,VPE4/A,VPE5,VPE7,VPE7/A,VWT4,VWT4/A,VXEB/A,VXE4,VXE4/A,VXE6,VXE6/A,VXE7,VXE7/A,WMA4,WXE8,WXE8/A,W1/A
			1	(1)	-	1065305	LHE,LWD,L1,QAE2,QHE,QXE,QXEB,Q1,Q2,RHE,R1,SHE,SHEZ,SWE,SXE,SXEB,S1,VXE,VXEB,V1,W1
4	31204-ZA0-003	CONTACTOR ASSY.	1	-	-		HEA,HEA2,HEA2/A,HEA8,HEA8/A,LHE,LHE/A,LTJ,LWD,LWD1,LWD1/A,LXE,LXE/A,LXE8,LXE8/A,PAE2,PAE2/A,PXE8,PXE8/A,QAE,QAE2/A,QAE6,QAE6/A,QHE,QHE4,QHE4/A,QHR4,QHR4/A,QKE3,QKE3/A,QKE4,QME2,QME2/A,QSC,QSC9,QSC9/A,QSE,QSE/A,QSE2,QSE8,QSE8/A,QXB6,QXB6/A,QXE,QXE/A,QXEB,QXE4,QXE4/A,QXE6,QXE6/A,QXE8,QXE8/A,RHE,RHE4/RHE4/A,SHE,SHEZ,SKE1,SME1,SME1/A,SWE,SXE,SXE/A,SXEB,SXEB/A,SXE4,SXE4/A,SXE8,SXE8/A,VDE,VDE2,VDE2/A,VEB6,VKB2,VKB2/A,VKE4,VME2,VME2/A,VME4,VMS2,VPE4,VPE4/A,VPE5,VPE7,VPE7/A,VWT4,VWT4/A,VXE,VXEB,VXEB/A,VXE4,VXE4/A,VXE6,VXE6/A,VXE7,VXE7/A,WMA4,WXE8,WXE8/A
5	31207-ZH9-003	CLUTCH COMP., OVERRUNNING ...	-	(1)	-		HEA,HEA2,HEA2/A,HEA8,HEA8/A,LHE/A,LTJ,LWD1,LWD1/A,LXE,LXE/A,LXE8,LXE8/A,L1/A,PAE2,PAE2/A,PXE8,PXE8/A,QAE,QAE2/A,QAE6,QAE6/A,QHE4,QHE4/A,QHR4,QHR4/A,QKE3,QKE3/A,QKE4,QME2,QME2/A,QSC,QSC9,QSC9/A,QSE,QSE/A,QSE2,QSE8,QSE8/A,QXB6,QXB6/A,QXE,QXE4,QXE4/A,QXE6,QXE6/A,QXE8,QXE8/A,Q1/A,RHE4,RHE4/A,R1/A,SKE1,SME1,SME1/A,SXE/A,SXE8/A,SXE4,SXE4/A,SXE8,SXE8/A,S1/A,VDE,VDE2,VDE2/A,VEB6,VKB2,VKB2/A,VKE4,VME2,VME2/A,VME4,VMS2,VPE4,VPE4/A,VPE5,VPE7,VPE7/A,VWT4,VWT4/A,VXEB/A,VXE4,VXE4/A,VXE6,VXE6/A,VXE7,VXE7/A,WMA4,WXE8,WXE8/A,W1/A
			1	(1)	-	1065305	LHE,LWD,L1,QAE2,QHE,QXE,QXEB,Q1,Q2,RHE,R1,SHE,SHEZ,SWE,SXE,SXEB,S1,VXE,VXEB,V1,W1
6	31211-ZE2-003	BRACKET, CENTER	1	-	-		HEA,HEA2,HEA2/A,HEA8,HEA8/A,LHE,LHE/A,LTJ,LWD,LWD1,LWD1/A,LXE,LXE/A,LXE8,LXE8/A,PAE2,PAE2/A,PXE8,PXE8/A,QAE,QAE2,QAE2/A,QAE6,QAE6/A,QHE,QHE4,QHE4/A,QHR4,QHR4/A,QKE3,QKE3/A,QKE4,QME2,QME2/A,QSC,QSC9,QSC9/A,QSE,QSE/A,QSE2,QSE8,QSE8/A,QXB6,QXB6/A,QXE,QXE/A,QXEB,QXE4,QXE4/A,QXE6,QXE6/A,QXE8,QXE8/A,RHE,RHE4,RHE4/A,SHE,SHEZ,SKE1,SME1,SME1/A,SWE,SXE,SXE/A,SXEB,SXEB/A,SXE4,SXE4/A,SXE8,SXE8/A,VDE,VDE2,VDE2/A,VEB6,VKB2,VKB2/A,VKE4,VME2,VME2/A,VME4,VMS2,VPE4,VPE4/A,VPE5,VPE7,VPE7/A,VWT4,VWT4/A,VXE,VXEB,VXEB/A,VXE4,VXE4/A,VXE6,VXE6/A,VXE7,VXE7/A,WMA4,WXE8,WXE8/A
7	31212-ZE2-003	BRACKET, FR.	-	(1)	-		HEA,HEA2,HEA2/A,HEA8,HEA8/A,LHE,LHE/A,LTJ,LWD,LWD1,LWD1/A,LXE,LXE/A,LXE8,LXE8/A,PAE2,PAE2/A,PXE8,PXE8/A,QAE,QAE2,QAE2/A,QAE6,QAE6/A,QHE,QHE4,QHE4/A,QHR4,QHR4/A,QKE3,QKE3/A,QKE4,QME2,QME2/A,QSC,QSC9,QSC9/A,QSE,QSE/A,QSE2,QSE8,QSE8/A,QXB6,QXB6/A,QXE,QXE/A,QXEB,QXE4,QXE4/A,QXE6,QXE6/A,QXE8,QXE8/A,RHE,RHE4,RHE4/A,SHE,SHEZ,SKE1,SME1,SME1/A,SWE,SXE,SXE/A,SXEB,SXEB/A,SXE4,SXE4/A,SXE8,SXE8/A,VDE,VDE2,VDE2/A,VEB6,VKB2,VKB2/A,VKE4,VME2,VME2/A,VME4,VMS2,VPE4,VPE4/A,VPE5,VPE7,VPE7/A,VWT4,VWT4/A,VXE,VXEB,VXEB/A,VXE4,VXE4/A,VXE6,VXE6/A,VXE7,VXE7/A,WMA4,WXE8,WXE8/A
			-	(1)	-		



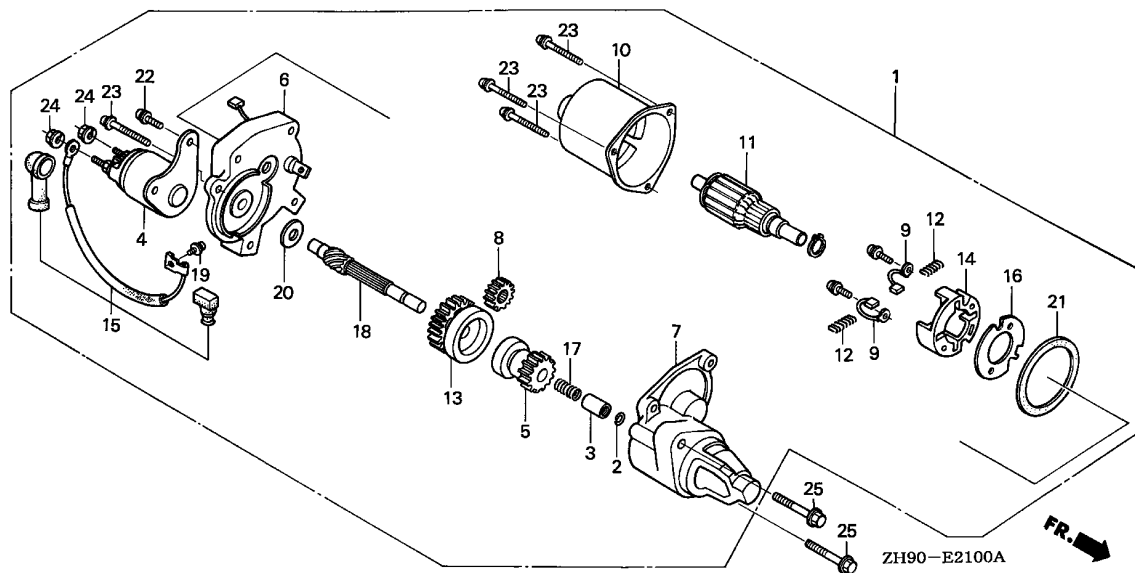

Ref. No.	Part No.	Description	Reqd. QTY			Serial No.	Parts catalogue code
			(1)	(2)	(3)		
8	31213-ZE2-003	GEAR, DRIVE PINION	1	-	-	-----	HEA,HEA2,HEA2/A,HEA8,HEA8/A,LHE,LHE/A,LTJ,LWD,LWD1,LWD1/A,LXE,LXE/A,LXE8,LXE8/A,PAE2,PAE2/A,PXE8,PXE8/A,QAE,QAE2,QAE2/A,QAE6,QAE6/A,QHE,QHE4,QHE4/A,QHR4,QHR4/A,QKE3,QKE3/A,QKE4,QME2,QME2/A,QSC,QSC9,QSC9/A,QSE,QSE/A,QSE2,QSE8,QSE8/A,QXB6,QXB6/A,QXE,QXE/A,QXEB,QXE4,QXE4/A,QXE6,QXE6/A,QXE8,QXE8/A,RHE,RHE4,RHE4/A,SHE,SHEZ,SKE1,SME1,SME1/A,SWE,SXE,SXE/A,SXEB,SXEB/A,SXE4,SXE4/A,SXE8,SXE8/A,VDE,VDE2,VDE2/A,VEB6,VKB2,VKB2/A,VKE4,VME2,VME2/A,VME4,VMS2,VPE4,VPE4/A,VPE5,VPE7,VPE7/A,VWT4,VWT4/A,VXE,VXEB,VXEB/A,VXE4,VXE4/A,VXE6,VXE6/A,VXE7,VXE7/A,WMA4,WXE8,WXE8/A
9	31215-ZE2-003	BRUSH	-	(1)	-	-----	HEA,HEA2,HEA2/A,HEA8,HEA8/A,LHE,LHE/A,LTJ,LWD,LWD1,LWD1/A,LXE,LXE/A,LXE8,LXE8/A,PAE2,PAE2/A,PXE8,PXE8/A,QAE,QAE2,QAE2/A,QAE6,QAE6/A,QHE,QHE4,QHE4/A,QHR4,QHR4/A,QKE3,QKE3/A,QKE4,QME2,QME2/A,QSC,QSC9,QSC9/A,QSE,QSE/A,QSE2,QSE8,QSE8/A,QXB6,QXB6/A,QXE,QXE/A,QXEB,QXE4,QXE4/A,QXE6,QXE6/A,QXE8,QXE8/A,RHE,RHE4,RHE4/A,SHE,SHEZ,SKE1,SME1,SME1/A,SWE,SXE,SXE/A,SXEB,SXEB/A,SXE4,SXE4/A,SXE8,SXE8/A,VDE,VDE2,VDE2/A,VEB6,VKB2,VKB2/A,VKE4,VME2,VME2/A,VME4,VMS2,VPE4,VPE4/A,VPE5,VPE7,VPE7/A,VWT4,VWT4/A,VXE,VXEB,VXEB/A,VXE4,VXE4/A,VXE6,VXE6/A,VXE7,VXE7/A,WMA4,WXE8,WXE8/A
			-	(2)	-	-----	

Ref. No.	Part No.	Description	Reqd. QTY			Serial No.	Parts catalogue code
			(1)	(2)	(3)		
10	31216-ZE2-003	YOKE COMP.	1	-	-	HEA,HEA2,HEA2/A,HEA8,HEA8/A,LHE,LHE/A,LTJ,LWD,LWD1,LWD1/A,LXE LXE/A,LXE8,LXE8/A,PAE2,PAE2/A,PXE8,PXE8/A,QAE,QAE2,QAE2/A,QAE6 QAE6/A,QHE,QHE4,QHE4/A,QHR4,QHR4/A,QKE3,QKE3/A,QKE4,QME2,QME2/A QSC,QSC9,QSC9/A,QSE,QSE/A,QSE2,QSE8,QSE8/A,QXB6,QXB6/A,QXE,QXE/A QXEB,QXE4,QXE4/A,QXE6,QXE6/A,QXE8,QXE8/A,RHE,RHE4,RHE4/A,SHE,SHEZ SKE1,SME1,SME1/A,SWE,SXE,SXE/A,SXEB,SXEB/A,SXE4,SXE4/A,SXE8 SXE8/A,VDE,VDE2,VDE2/A,VEB6,VKB2,VKB2/A,VKE4,VME2,VME2/A,VME4 VMS2,VPE4,VPE4/A,VPE5,VPE7,VPE7/A,VWT4,VWT4/A,VXE,VXEB,VXEB/A VXE4,VXE4/A,VXE6,VXE6/A,VXE7,VXE7/A,WMA4,WXE8,WXE8/A	
			-	(1)	-		
11	31217-ZE2-003	ARMATURE COMP.	1	-	-	HEA,HEA2,HEA2/A,HEA8,HEA8/A,LHE,LHE/A,LTJ,LWD,LWD1,LWD1/A,LXE LXE/A,LXE8,LXE8/A,PAE2,PAE2/A,PXE8,PXE8/A,QAE,QAE2,QAE2/A,QAE6 QAE6/A,QHE,QHE4,QHE4/A,QHR4,QHR4/A,QKE3,QKE3/A,QKE4,QME2,QME2/A QSC,QSC9,QSC9/A,QSE,QSE/A,QSE2,QSE8,QSE8/A,QXB6,QXB6/A,QXE,QXE/A QXEB,QXE4,QXE4/A,QXE6,QXE6/A,QXE8,QXE8/A,RHE,RHE4,RHE4/A,SHE,SHEZ SKE1,SME1,SME1/A,SWE,SXE,SXE/A,SXEB,SXEB/A,SXE4,SXE4/A,SXE8 SXE8/A,VDE,VDE2,VDE2/A,VEB6,VKB2,VKB2/A,VKE4,VME2,VME2/A,VME4 VMS2,VPE4,VPE4/A,VPE5,VPE7,VPE7/A,VWT4,VWT4/A,VXE,VXEB,VXEB/A VXE4,VXE4/A,VXE6,VXE6/A,VXE7,VXE7/A,WMA4,WXE8,WXE8/A	
			-	(1)	-		
12	31219-ZE2-003	SPRING, BRUSH RETURN	4	-	-	HEA,HEA2,HEA2/A,HEA8,HEA8/A,LHE,LHE/A,LTJ,LWD,LWD1,LWD1/A,LXE LXE/A,LXE8,LXE8/A,PAE2,PAE2/A,PXE8,PXE8/A,QAE,QAE2,QAE2/A,QAE6 QAE6/A,QHE,QHE4,QHE4/A,QHR4,QHR4/A,QKE3,QKE3/A,QKE4,QME2,QME2/A QSC,QSC9,QSC9/A,QSE,QSE/A,QSE2,QSE8,QSE8/A,QXB6,QXB6/A,QXE,QXE/A QXEB,QXE4,QXE4/A,QXE6,QXE6/A,QXE8,QXE8/A,RHE,RHE4,RHE4/A,SHE,SHEZ SKE1,SME1,SME1/A,SWE,SXE,SXE/A,SXEB,SXEB/A,SXE4,SXE4/A,SXE8 SXE8/A,VDE,VDE2,VDE2/A,VEB6,VKB2,VKB2/A,VKE4,VME2,VME2/A,VME4 VMS2,VPE4,VPE4/A,VPE5,VPE7,VPE7/A,VWT4,VWT4/A,VXE,VXEB,VXEB/A VXE4,VXE4/A,VXE6,VXE6/A,VXE7,VXE7/A,WMA4,WXE8,WXE8/A	
			-	(1)	-		
13	31222-ZE3-791	GEAR, REDUCTION	1	-	-	HEA,HEA2,HEA2/A,HEA8,HEA8/A,LHE,LHE/A,LTJ,LWD,LWD1,LWD1/A,LXE LXE/A,LXE8,LXE8/A,PAE2,PAE2/A,PXE8,PXE8/A,QAE,QAE2,QAE2/A,QAE6 QAE6/A,QHE,QHE4,QHE4/A,QHR4,QHR4/A,QKE3,QKE3/A,QKE4,QME2,QME2/A QSC,QSC9,QSC9/A,QSE,QSE/A,QSE2,QSE8,QSE8/A,QXB6,QXB6/A,QXE,QXE/A QXEB,QXE4,QXE4/A,QXE6,QXE6/A,QXE8,QXE8/A,RHE,RHE4,RHE4/A,SHE,SHEZ SKE1,SME1,SME1/A,SWE,SXE,SXE/A,SXEB,SXEB/A,SXE4,SXE4/A,SXE8 SXE8/A,VDE,VDE2,VDE2/A,VEB6,VKB2,VKB2/A,VKE4,VME2,VME2/A,VME4 VMS2,VPE4,VPE4/A,VPE5,VPE7,VPE7/A,VWT4,VWT4/A,VXE,VXEB,VXEB/A VXE4,VXE4/A,VXE6,VXE6/A,VXE7,VXE7/A,WMA4,WXE8,WXE8/A	
			-	(4)	-		
14	31231-ZE2-003	HOLDER, BRUSH	1	-	-	HEA,HEA2,HEA2/A,HEA8,HEA8/A,LHE,LHE/A,LTJ,LWD,LWD1,LWD1/A,LXE LXE/A,LXE8,LXE8/A,PAE2,PAE2/A,PXE8,PXE8/A,QAE,QAE2,QAE2/A,QAE6 QAE6/A,QHE,QHE4,QHE4/A,QHR4,QHR4/A,QKE3,QKE3/A,QKE4,QME2,QME2/A QSC,QSC9,QSC9/A,QSE,QSE/A,QSE2,QSE8,QSE8/A,QXB6,QXB6/A,QXE,QXE/A QXEB,QXE4,QXE4/A,QXE6,QXE6/A,QXE8,QXE8/A,RHE,RHE4,RHE4/A,SHE,SHEZ SKE1,SME1,SME1/A,SWE,SXE,SXE/A,SXEB,SXEB/A,SXE4,SXE4/A,SXE8 SXE8/A,VDE,VDE2,VDE2/A,VEB6,VKB2,VKB2/A,VKE4,VME2,VME2/A,VME4 VMS2,VPE4,VPE4/A,VPE5,VPE7,VPE7/A,VWT4,VWT4/A,VXE,VXEB,VXEB/A VXE4,VXE4/A,VXE6,VXE6/A,VXE7,VXE7/A,WMA4,WXE8,WXE8/A	
			-	(1)	-		



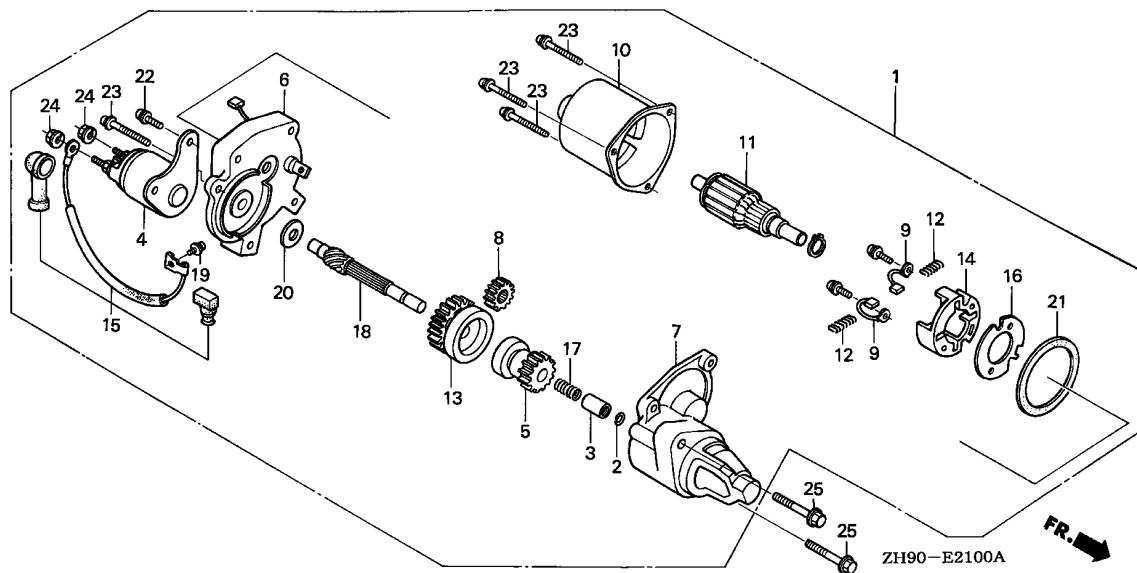

Ref. No.	Part No.	Description	Reqd. QTY			Serial No.	Parts catalogue code
			(1)	(2)	(3)		
15	31232-ZE3-003	WIRE, WATER COVER	1	-	-	-----	HEA,HEA2,HEA2/A,HEA8,HEA8/A,LHE,LHE/A,LTJ,LWD,LWD1,LWD1/A,LXE,LXE/A,LXE8,LXE8/A,PAE2,PAE2/A,PXE8,PXE8/A,QAE,QAE2,QAE2/A,QAE6,QAE6/A,QHE,QHE4,QHE4/A,QHR4,QHR4/A,QKE3,QKE3/A,QKE4,QME2,QME2/A,QSC,QSC9,QSC9/A,QSE,QSE/A,QSE2,QSE8,QSE8/A,QXB6,QXB6/A,QXE,QXE/A,QXEB,QXE4,QXE4/A,QXE6,QXE6/A,QXE8,QXE8/A,RHE,RHE4,RHE4/A,SHE,SHEZ,SKE1,SME1,SME1/A,SWE,SXE,SXE/A,SXEB,SXEB/A,SXE4,SXE4/A,SXE8,SXE8/A,VDE,VDE2,VDE2/A,VEB6,VKB2,VKB2/A,VKE4,VME2,VME2/A,VME4,VMS2,VPE4,VPE4/A,VPE5,VPE7,VPE7/A,VWT4,VWT4/A,VXE,VXEB,VXEB/A,VXE4,VXE4/A,VXE6,VXE6/A,VXE7,VXE7/A,WMA4,WXE8,WXE8/A
			-	(1)	-		
16	31233-ZE2-003	INSULATOR	1	-	-	-----	HEA,HEA2,HEA2/A,HEA8,HEA8/A,LHE,LHE/A,LTJ,LWD,LWD1,LWD1/A,LXE,LXE/A,LXE8,LXE8/A,PAE2,PAE2/A,PXE8,PXE8/A,QAE,QAE2,QAE2/A,QAE6,QAE6/A,QHE,QHE4,QHE4/A,QHR4,QHR4/A,QKE3,QKE3/A,QKE4,QME2,QME2/A,QSC,QSC9,QSC9/A,QSE,QSE/A,QSE2,QSE8,QSE8/A,QXB6,QXB6/A,QXE,QXE/A,QXEB,QXE4,QXE4/A,QXE6,QXE6/A,QXE8,QXE8/A,RHE,RHE4,RHE4/A,SHE,SHEZ,SKE1,SME1,SME1/A,SWE,SXE,SXE/A,SXEB,SXEB/A,SXE4,SXE4/A,SXE8,SXE8/A,VDE,VDE2,VDE2/A,VEB6,VKB2,VKB2/A,VKE4,VME2,VME2/A,VME4,VMS2,VPE4,VPE4/A,VPE5,VPE7,VPE7/A,VWT4,VWT4/A,VXE,VXEB,VXEB/A,VXE4,VXE4/A,VXE6,VXE6/A,VXE7,VXE7/A,WMA4,WXE8,WXE8/A
			-	(1)	-		

Ref. No.	Part No.	Description	Reqd. QTY			Serial No.	Parts catalogue code
			(1)	(2)	(3)		
17	31244-ZH9-003	SPRING	1	(1)	-		HEA,HEA2,HEA2/A,HEA8,HEA8/A,LHE/A,LTJ,LWD1,LWD1/A,LXE,LXE/A,LXE8,LXE8/A,L1/A,PAE2,PAE2/A,PXE8,PXE8/A,QAE,QAE2/A,QAE6,QAE6/A,QHE4,QHE4/A,QHR4,QHR4/A,QKE3,QKE3/A,QKE4,QME2,QME2/A,QSC,QSC9,QSC9/A,QSE,QSE/A,QSE2,QSE8,QSE8/A,QXB6,QXB6/A,QXE/A,QXE4,QXE4/A,QXE6,QXE6/A,QXE8,QXE8/A,Q1/A,RHE4,RHE4/A,R1/A,SKE1,SME1,SME1/A,SXE/A,SXEB/A,SXE4,SXE4/A,SXE8,SXE8/A,S1/A,VDE,VDE2,VDE2/A,VEB6,VKB2,VKB2/A,VKE4,VME2,VME2/A,VME4,VMS2,VPE4,VPE4/A,VPE5,VPE7,VPE7/A,VWT4,VWT4/A,VXEB/A,VXE4,VXE4/A,VXE6,VXE6/A,VXE7,VXE7/A,WMA4,WXE8,WXE8/A,W1/A
			1	(1)	-	1065305	LHE,LWD,L1,QAE2,QHE,QXE,QXEB,Q1,Q2,RHE,R1,SHE,SHEZ,SWE,SXE,SXEB,S1,VXE,VXEB,V1,W1
18	31245-ZH9-003	SHAFT	1	(1)	-		HEA,HEA2,HEA2/A,HEA8,HEA8/A,LHE/A,LTJ,LWD1,LWD1/A,LXE,LXE/A,LXE8,LXE8/A,L1/A,PAE2,PAE2/A,PXE8,PXE8/A,QAE,QAE2/A,QAE6,QAE6/A,QHE4,QHE4/A,QHR4,QHR4/A,QKE3,QKE3/A,QKE4,QME2,QME2/A,QSC,QSC9,QSC9/A,QSE,QSE/A,QSE2,QSE8,QSE8/A,QXB6,QXB6/A,QXE/A,QXE4,QXE4/A,QXE6,QXE6/A,QXE8,QXE8/A,Q1/A,RHE4,RHE4/A,R1/A,SKE1,SME1,SME1/A,SXE/A,SXEB/A,SXE4,SXE4/A,SXE8,SXE8/A,S1/A,VDE,VDE2,VDE2/A,VEB6,VKB2,VKB2/A,VKE4,VME2,VME2/A,VME4,VMS2,VPE4,VPE4/A,VPE5,VPE7,VPE7/A,VWT4,VWT4/A,VXEB/A,VXE4,VXE4/A,VXE6,VXE6/A,VXE7,VXE7/A,WMA4,WXE8,WXE8/A,W1/A
			1	(1)	-	1065305	LHE,LWD,L1,QAE2,QHE,QXE,QXEB,Q1,Q2,RHE,R1,SHE,SHEZ,SWE,SXE,SXEB,S1,VXE,VXEB,V1,W1
19	90110-ZE2-003	SCREW-WASHER, 4X6	1	-	-		HEA,HEA2,HEA2/A,HEA8,HEA8/A,LHE,LHE/A,LTJ,LWD,LWD1,LWD1/A,LXE,LXE/A,LXE8,LXE8/A,PAE2,PAE2/A,PXE8,PXE8/A,QAE,QAE2,QAE2/A,QAE6,QAE6/A,QHE4,QHE4/A,QHR4,QHR4/A,QKE3,QKE3/A,QKE4,QME2,QME2/A,QSC,QSC9,QSC9/A,QSE,QSE/A,QSE2,QSE8,QSE8/A,QXB6,QXB6/A,QXE,QXE/A,QXEB,QXE4,QXE4/A,QXE6,QXE6/A,QXE8,QXE8/A,RHE,RHE4,RHE4/A,SHE,SHEZ,SKE1,SME1,SME1/A,SWE,SXE,SXE/A,SXEB,SXEB/A,SXE4,SXE4/A,SXE8,SXE8/A,VDE,VDE2,VDE2/A,VEB6,VKB2,VKB2/A,VKE4,VME2,VME2/A,VME4,VMS2,VPE4,VPE4/A,VPE5,VPE7,VPE7/A,VWT4,VWT4/A,VXE,VXEB,VXEB/A,VXE4,VXE4/A,VXE6,VXE6/A,VXE7,VXE7/A,WMA4,WXE8,WXE8/A
20	90403-ZH9-003	WASHER, SK	-	(1)	-		HEA,HEA2,HEA2/A,HEA8,HEA8/A,LHE,LHE/A,LTJ,LWD,LWD1,LWD1/A,LXE,LXE/A,LXE8,LXE8/A,L1/A,PAE2,PAE2/A,PXE8,PXE8/A,QAE,QAE2/A,QAE6,QAE6/A,QHE4,QHE4/A,QHR4,QHR4/A,QKE3,QKE3/A,QKE4,QME2,QME2/A,QSC,QSC9,QSC9/A,QSE,QSE/A,QSE2,QSE8,QSE8/A,QXB6,QXB6/A,QXE,QXE/A,QXEB,QXE4,QXE4/A,QXE6,QXE6/A,QXE8,QXE8/A,RHE,RHE4,RHE4/A,SHE,SHEZ,SKE1,SME1,SME1/A,SWE,SXE,SXE/A,SXEB,SXEB/A,SXE4,SXE4/A,SXE8,SXE8/A,VDE,VDE2,VDE2/A,VEB6,VKB2,VKB2/A,VKE4,VME2,VME2/A,VME4,VMS2,VPE4,VPE4/A,VPE5,VPE7,VPE7/A,VWT4,VWT4/A,VXE,VXEB,VXEB/A,VXE4,VXE4/A,VXE6,VXE6/A,VXE7,VXE7/A,WMA4,WXE8,WXE8/A
			1	(1)	-	1065305	LHE,LWD,L1,QAE2,QHE,QXE,QXEB,Q1,Q2,RHE,R1,SHE,SHEZ,SWE,SXE,SXEB,S1,VXE,VXEB,V1,W1
21	91601-ZE2-003	PACKING	1	-	-		HEA,HEA2,HEA2/A,HEA8,HEA8/A,LHE,LHE/A,LTJ,LWD,LWD1,LWD1/A,LXE,LXE/A,LXE8,LXE8/A,PAE2,PAE2/A,PXE8,PXE8/A,QAE,QAE2,QAE2/A,QAE6,QAE6/A,QHE4,QHE4/A,QHR4,QHR4/A,QKE3,QKE3/A,QKE4,QME2,QME2/A,QSC,QSC9,QSC9/A,QSE,QSE/A,QSE2,QSE8,QSE8/A,QXB6,QXB6/A,QXE,QXE/A,QXEB,QXE4,QXE4/A,QXE6,QXE6/A,QXE8,QXE8/A,RHE,RHE4,RHE4/A,SHE,SHEZ,SKE1,SME1,SME1/A,SWE,SXE,SXE/A,SXEB,SXEB/A,SXE4,SXE4/A,SXE8,SXE8/A,VDE,VDE2,VDE2/A,VEB6,VKB2,VKB2/A,VKE4,VME2,VME2/A,VME4,VMS2,VPE4,VPE4/A,VPE5,VPE7,VPE7/A,VWT4,VWT4/A,VXE,VXEB,VXEB/A,VXE4,VXE4/A,VXE6,VXE6/A,VXE7,VXE7/A,WMA4,WXE8,WXE8/A
22	93892-05014-18	SCREW-WASHER, 5X14	-	(1)	-		HEA,HEA2,LHE,LTJ,LWD,LXE,L1,QAE,QAE2,QAE6,QHE,QHE4,QME2,QSC,QSC9,QXE,QXEB,QXE4,QXE6,Q1,Q2,RHE,RHE4,R1,SHE,SHEZ,SME1,SWE,SXE,SXEB,SXE4,S1,VDE,VDE2,VEB6,VXE,VXEB,VXE4
			-	(2)	-	1221119	V1,W1,W1/A



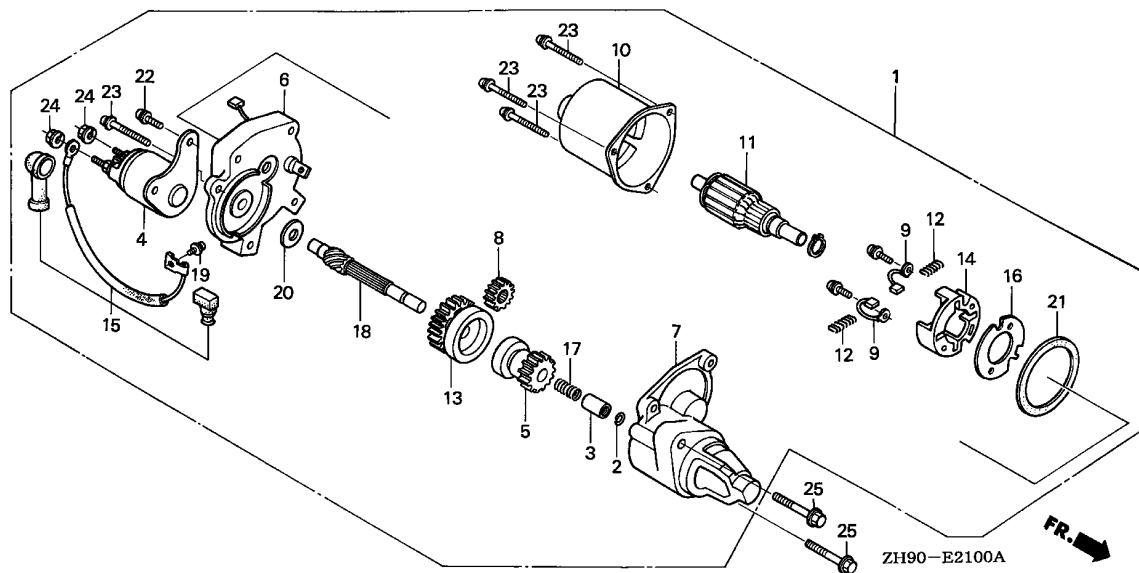

Ref. No.	Part No.	Description	Reqd. QTY			Serial No.	Parts catalogue code	
			(1)	(2)	(3)			
22)	90007-ZE2-003	BOLT-WASHER, 5X14	2	(2)	-	-----	HEA2/A,HEA8,HEA8/A,LHE/A,LWD1,LWD1/A,LXE/A,LXE8,LXE8/A,L1/A,PAE2 PAE2/A,PXE8,PXE8/A,QAE2/A,QAE6/A,QHE4/A,QHR4,QHR4/A,QKE3,QKE3/A QKE4,QME2/A,QSC9/A,QSE,QSE/A,QSE2,QSE8,QSE8/A,QXB6,QXB6/A,QXE/A QXE4/A,QXE6/A,QXE8,QXE8/A,Q1/A,RHE4/A,R1/A,SKE1,SME1/A,SXE/A SXEB/A,SXE4/A,SXE8,SXE8/A,S1/A,VDE2/A,VKB2,VKB2/A,VKE4,VME2 VME2/A,VME4,VMS2,VPE4,VPE4/A,VPE5,VPE7,VPE7/A,VWT4,VWT4/A,VXEB/A VXE4/A,VXE6,VXE6/A,VXE7,VXE7/A,WMA4,WXE8,WXE8/A	
			2	(2)	-	1221120	-----	HEA,HEA2,LHE,LTJ,LWD,LXE,L1,QAE,QAE2,QAE6,QHE,QHE4,QME2,QSC,QSC9 QXE,QXEB,QXE4,QXE6,Q1,Q2,RHE,RHE4,R1,SHE,SHEZ,SME1,SWE,SXE,SXEB SXE4,S1,VDE,VDE2,VEB6,VXE,VXEB,VXE4
23	93892-05032-18	SCREW-WASHER, 5X32	4	-	-	-----	HEA,HEA2,HEA2/A,HEA8,HEA8/A,LHE,LHE/A,LTJ,LWD,LWD1,LWD1/A,LXE LXE/A,LXE8,LXE8/A,PAE2,PAE2/A,PXE8,PXE8/A,QAE,QAE2,QAE2/A,QAE6 QAE6/A,QHE,QHE4,QHE4/A,QHR4,QHR4/A,QKE3,QKE3/A,QKE4,QME2,QME2/A QSC,QSC9,QSC9/A,QSE,QSE/A,QSE2,QSE8,QSE8/A,QXB6,QXB6/A,QXE,QXE/A QXEB,QXE4,QXE4/A,QXE6,QXE6/A,QXE8,QXE8/A,RHE,RHE4,RHE4/A,SHE,SHEZ SKE1,SME1,SME1/A,SWE,SXE,SXE/A,SXEB,SXEB/A,SXE4,SXE4/A,SXE8 SXE8/A,VDE,VDE2,VDE2/A,VEB6,VKB2,VKB2/A,VKE4,VME2,VME2/A,VME4 VMS2,VPE4,VPE4/A,VPE5,VPE7,VPE7/A,VWT4,VWT4/A,VXE,VXEB,VXEB/A VXE4,VXE4/A,VXE6,VXE6/A,VXE7,VXE7/A,WMA4,WXE8,WXE8/A	
			-	(4)	-			

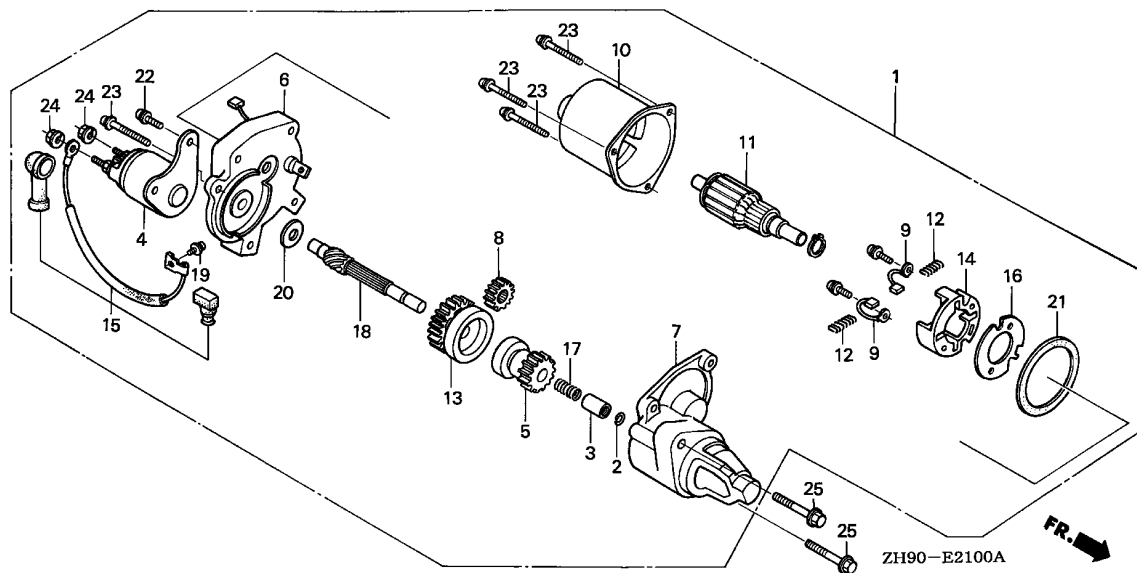

Ref. No.	Part No.	Description	Reqd. QTY			Serial No.	Parts catalogue code
			(1)	(2)	(3)		
24	94070-06080	NUT-WASHER, 6MM	2	-	-	-----	HEA,HEA2,HEA2/A,HEA8,HEA8/A,LHE,LHE/A,LTJ,LWD,LWD1,LWD1/A,LXE,LXE/A,LXE8,LXE8/A,PAE2,PAE2/A,PXE8,PXE8/A,QAE,QAE2,QAE2/A,QAE6,QAE6/A,QHE,QHE4,QHE4/A,QHR4,QHR4/A,QKE3,QKE3/A,QKE4,QME2,QME2/A,QSC,QSC9,QSC9/A,QSE,QSE/A,QSE2,QSE8,QSE8/A,QXB6,QXB6/A,QXE,QXE/A,QXEB,QXE4,QXE4/A,QXE6,QXE6/A,QXE8,QXE8/A,RHE,RHE4,RHE4/A,SHE,SHEZ,SKE1,SME1,SME1/A,SWE,SXE,SXE/A,SXEB,SXEB/A,SXE4,SXE4/A,SXE8,SXE8/A,VDE,VDE2,VDE2/A,VEB6,VKB2,VKB2/A,VKE4,VME2,VME2/A,VME4,VMS2,VPE4,VPE4/A,VPE5,VPE7,VPE7/A,VWT4,VWT4/A,VXE,VXEB,VXEB/A,VXE4,VXE4/A,VXE6,VXE6/A,VXE7,VXE7/A,WMA4,WXE8,WXE8/A
25	95701-08040-00	BOLT, FLANGE, 8X40	-	(2)	-	-----	HEA,HEA2,HEA2/A,HEA8,HEA8/A,LHE,LHE/A,LTJ,LWD,LWD1,LWD1/A,LXE,LXE/A,LXE8,LXE8/A,PAE2,PAE2/A,PXE8,PXE8/A,QAE,QAE2,QAE2/A,QAE6,QAE6/A,QHE,QHE4,QHE4/A,QHR4,QHR4/A,QKE3,QKE3/A,QKE4,QME2,QME2/A,QSC,QSC9,QSC9/A,QSE,QSE/A,QSE2,QSE8,QSE8/A,QXB6,QXB6/A,QXE,QXE/A,QXEB,QXE4,QXE4/A,QXE6,QXE6/A,QXE8,QXE8/A,RHE,RHE4,RHE4/A,SHE,SHEZ,SKE1,SME1,SME1/A,SWE,SXE,SXE/A,SXEB,SXEB/A,SXE4,SXE4/A,SXE8,SXE8/A,VDE,VDE2,VDE2/A,VEB6,VKB2,VKB2/A,VKE4,VME2,VME2/A,VME4,VMS2,VPE4,VPE4/A,VPE5,VPE7,VPE7/A,VWT4,VWT4/A,VXE,VXEB,VXEB/A,VXE4,VXE4/A,VXE6,VXE6/A,VXE7,VXE7/A,WMA4,WXE8,WXE8/A
			-	(2)	-	-----	



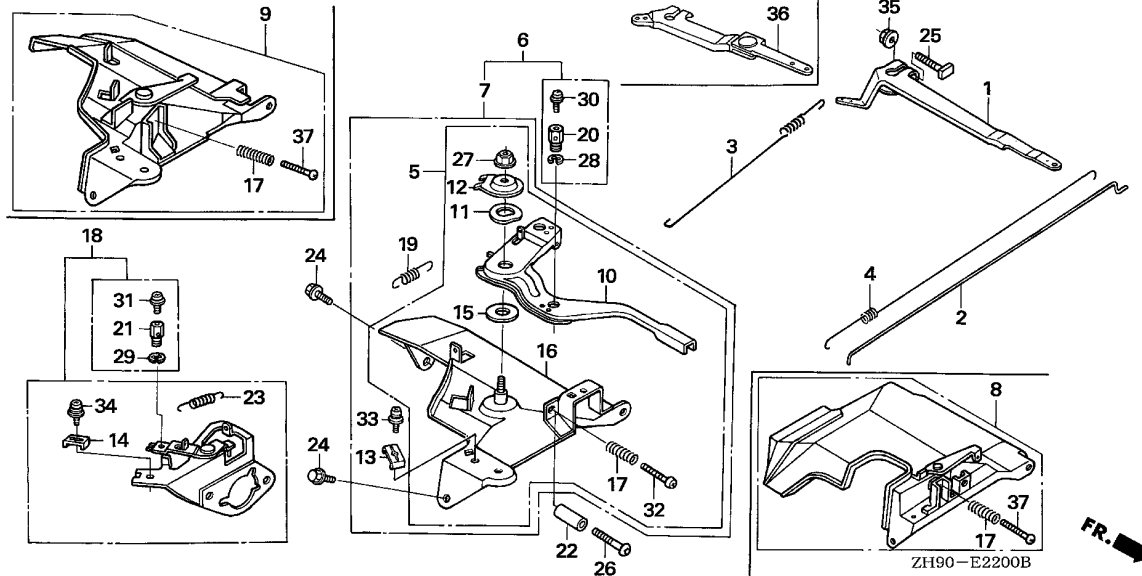

Ref. No.	L.O.N.	(Relative ref. Number) Description	F.R.T.
1		(36)	
1	1161A0	ARM, GOVERNOR	0.2
2	1161B1	ROD, GOVERNOR	0.3
3	1161C5	SPRING, GOVERNOR	0.2
4	1161C2	SPRING, THROTTLE RETURN	0.3
6		(8,9)	
	1161A5	CONTROL, THROTTLE/GOVERNOR ...	0.2
10	1161A8	LEVER, CONTROL	0.3
16	1161A2	BASE, CONTROL	0.3
18	3111G3	STAY, CHOKE CONTROL	0.2

Ref. No.	Part No.	Description	Reqd. QTY			Serial No.	Parts catalogue code
			(1)	(2)	(3)		
1	16551-ZE2-000	ARM, GOVERNOR	1	-	-	ES1,ES1/A,ES3,ES3/A,HA,HAQ,HA2,HA2/A,HEA,HEA2,HEA2/A,HEA8,HEA8/A,HH,HX,HX/A,HXQ4,HXQ4/A,HX26,HX26/A,HX8,HX8/A,LH,LH/A,LHB1,LHB3,LHB5,LHE,LHE/A,LHQ4,LJ,LJ/A,LJC,LJC/A,LJG,LJG/A,LSS,LT,LT/A,LTJ,LW,LW/A,LWD1,LWD1/A,LX,LX/A,LXE,LXE/A,LXE8,LXE8/A,LXQ4,LXQ4/A,LXU,LXU/A,LXZ,LX16,PA,PAE2,PAE2/A,PA2,PA2/A,PX,PX/A,PXE8,PXE8/A,PXU,PXU/A,PX26,PX26/A,QA,QAB1,QAB3,QAB3/A,QAE,QAE2,QAE2/A,QAE6,QAE6/A,QAG,QAG/A,QAG2,QAG2/A,QAQ,QAQ4,QAQ4/A,QAR2,QAR2/A,QAW,QAW/A,QA2,QA2/A,QD,QD/A,QE,QE/A,QH,QH/A,QHB5,QHC,QHE,QHE4,QHE4/A,QHP1,QHP1/A,QHQ4,QHQ4/A,QHR,QHR/A,QHR4,QHR4/A,QHZ,QHZ/A,QH26,QH26/A,QKE3,QKE3/A,QKE4,QL2,QME2,QME2/A,QMH,QMH/A,QP,QP/A,QSC,QSC9,QSC9/A,QSE,QSE/A,QSE2,QSE8,QSE8/A,QT,QT/A,QWA2,QWA4,QWA4/A,QWH2,QWH2/A,QX,QX/A,QXB,QXB/A,QXB6,QXB6/A,QXB7,QXB7/A,QXC,QXC4,QXC4/A,QXC6,QXC6/A,QXC9,QXC9/A,QXE,QXE/A,QXEB,QXE4,QXE4/A,QXE6,QXE6/A,QXE8,QXE8/A,QXQ4,QXQ4/A,QXU,QXU/A,QX26,QX26/A,RA,RA2,RA2/A,RD,RD/A,RH,RHE,RHE4,RHE4/A,RHQ4,RHQ4/A,RH26,RH26/A,RSC2,RSC2/A,RSS,RSS/A,RX,RX/A,RXQ4,RXQ4/A,RXU,RXU/A,SD,SD/A,SE,SE/A,SH,SH/A,SHE,SHEZ,SHQ4,SHQ4/A,SJ,SJ/A,SJG,SJG/A,SJP,SK,SKE1,SMC4,SMC4/A,SMD,SME1,SME1/A,SME6,SME6/A,SMX2,SN,SN/A,SW,SWA4,SWC4,SWC4/A,SWE,SX,SX/A,SXB,SXB/A,SXB7,SXB7/A,SXE,SXE/A,SXEB,SXEB/A,SXE4,SXE4/A,SXEB8,SXEB8/A,SXQ4,SXQ4/A,SXU,SXU/A,SX2,VA,VAW,VAW1,VA2,VA2/A,VDE,VDE2,VDE2/A,VD16,VEB6,VH,VMA4,VME2,VME2/A,VME4,VMX2,VM2,VM2/A,VNG1,VNG1/A,VNT2,VNT2/A,VN17,VN17/A,VPE4,VPE4/A,VPE5,VPE7,VPE7/A,VPX4,VPX4/A,VPX5,VPX7,VPX7/A,VSD,VSD/A,VSD3,VSD3/A,VSD7,VSD7/A,VSH7,VS3,VS37,VS37/A,VWN2,VWN2/A,VWT4,VWT4/A,VW12,VW12/A,VW22,VX,VX/A,VXB,VXB/A,VXB2,VXB6,VXB7,VXB7/A,VXE,VXEB,VXEB/A,VXE4,VXE4/A,VXE6,VXE6/A,VXE7,VXE7/A,VXG,VXQ4,VXQ4/A,VXTB,VXT1,VXT1/A,VXU,VXU/A,VXU1,VXU1/A,VX26,WMA4,WMT8,WMT8/A,WXE8,WXE8/A	

- 1 1

Ref. No.	Part No.	Description	Reqd. QTY			Serial No.	Parts catalogue code
			(1)	(2)	(3)		
2	16555-ZE2-000	ROD, GOVERNOR	1	-	-	-----	ES1,ES1/A,ES3,ES3/A,HA,HAQ,HA2,HA2/A,HEA,HEA2,HEA2/A,HEA8,HEA8/A,HH,HX,HX/A,HXQ4,HXQ4/A,HX26,HX26/A,HX8,HX8/A,LH,LH/A,LHB1,LHB3,LHB5,LHE,LHE/A,LHQ4,LJ,LJ/A,LJC,LJC/A,LJG,LJG/A,LSS,LT,LT/A,LTJ,LW,LW/A,LWD1,LWD1/A,LX,LX/A,LXE,LXE/A,LXE8,LXE8/A,LXQ4,LXQ4/A,LXU,LXU/A,LXZ,LX16,PA,PAE2,PAE2/A,PA2,PA2/A,PX,PX/A,PXE8,PXE8/A,PXU,PXU/A,PX26,PX26/A,QA,QAB1,QAB3,QAB3/A,QAE,QAE2,QAE2/A,QAE6,QAE6/A,QAG,QAG/A,QAG2,QAG2/A,QAQ,QAQ4,QAQ4/A,QAR2,QAR2/A,QAW,QAW/A,QA2,QA2/A,QD,QD/A,QE,QE/A,QH,QH/A,QHB5,QHC,QHE,QHE4,QHE4/A,QHP1,QHP1/A,QHQ4,QHQ4/A,QHR,QHR/A,QHR4,QHR4/A,QHZ,QHZ/A,QH26,QH26/A,QKE3,QKE3/A,QKE4,QL2,QME2,QME2/A,QMH,QMH/A,QP,QP/A,QSC,QSC9,QSC9/A,QSE,QSE/A,QSE2,QSE8,QSE8/A,QT,QT/A,QWA2,QWA4,QWA4/A,QWH2,QWH2/A,QX,QX/A,QXB,QXB/A,QXB6,QXB6/A,QXB7,QXB7/A,QXC,QXC4,QXC4/A,QXC6,QXC6/A,QXC9,QXC9/A,QXE,QXE/A,QXEB,QXEB/A,QXE4,QXE4/A,QXE6,QXE6/A,QXE8,QXE8/A,QXQ4,QXQ4/A,QXU,QXU/A,QX26,QX26/A,RA,RA2,RA2/A,RD,RD/A,RH,RHE,RHE4,RHE4/A,RHQ4,RHQ4/A,RH26,RH26/A,RSC2,RSC2/A,RSS,RSS/A,RX,RX/A,RXQ4,RXQ4/A,RXU,RXU/A,SD,SD/A,SE,SE/A,SH,SH/A,SHE,SHEZ,SHQ4,SHQ4/A,SJ,SJ/A,SJG,SJG/A,SJP,SK,SK1,SMC4,SMC4/A,SMD,SME1,SME1/A,SME6,SME6/A,SMX2,SN,SN/A,SW,SWA4,SWC4,SWC4/A,SWE,SX,SX/A,SXB,SXB/A,SXB7,SXB7/A,SXE,SXE/A,SXEB,SXEB/A,SXE4,SXE4/A,SXE8,SXE8/A,SXQ4,SXQ4/A,SXU,SXU/A,SX2,VA,VAG2,VAG2/A,VAW,VAW1,VA2,VA2/A,VDE,VDE2,VDE2/A,VD16,VEB6,VH,VKB2,VKB2/A,VKE4,VKX4,VMA4,VME2,VME2/A,VME4,VMS2,VMT,VMT/A,VMX2,VM2,VM2/A,VNG1,VNG1/A,VNT2,VNT2/A,VN17,VN17/A,VPE4,VPE4/A,VPE5,VPE7,VPE7/A,VPX4,VPX4/A,VPX5,VPX7,VPX7/A,VSD,VSD/A,VSD3,VSD3/A,VSD7,VSD7/A,VSH7,VS3,VS37,VS37/A,VWA,VWA2,VWA2/A,VWN2,VWN2/A,VWT4,VWT4/A,VW12,VW12/A,VW22,VX,VX/A,VXB,VXB/A,VXB2,VXB6,VXB7,VXB7/A,VXE,VXEB,VXEB/A,VXE4,VXE4/A,VXE6,VXE6/A,VXE7,VXE7/A,VXG,VXQ4,VXQ4/A,VXTB,VXT1,VXT1/A,VXU,VXU/A,VXU1,VXU1/A,VX26,WMA4,WMT8,WMT8/A,WX8,WX8/A
	16555-ZB7-000	1	-	-	-----	ESS,ESS/A



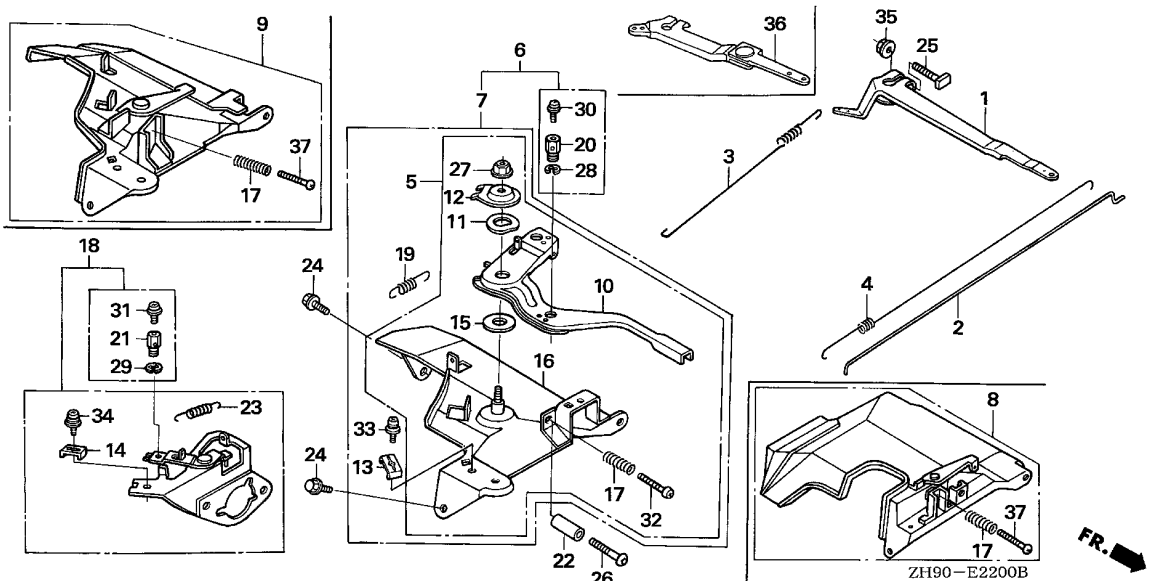

2

Ref. No.	Part No.	Description	Reqd. QTY			Serial No.	Parts catalogue code
			(1)	(2)	(3)		
3	16561-ZE2-000	SPRING, GOVERNOR	1	-	-	-----	ESS,ESS/A,ES1,ES1/A,ES3,ES3/A,HA,HAQ,HA2,HA2/A,HEA,HEA2,HEA2/A,HEA8,HEA8/A,HH,HX,HX/A,HXQ4,HXQ4/A,HX26,HX26/A,HX8,HX8/A,LH,LH/A,LHB1,LHB3,LHB5,LHE,LHE/A,LHQ4,LJ,LJ/A,LJC,LJC/A,LJG,LJG/A,LSS,LT,LT/A,LTJ,LW,LW/A,LWD1,LWD1/A,LX,LX/A,LXE,LXE/A,LXE8,LXE8/A,LXQ4,LXQ4/A,LXU,LXU/A,LXZ,LX16,PA,PAE2,PAE2/A,PA2,PA2/A,PX,PX/A,PXE8,PXE8/A,PXU,PXU/A,PX26,PX26/A,QA,QAB1,QAB3,QAB3/A,QAE,QAE2,QAE2/A,QAE6,QAE6/A,QAG,QAG/A,QAG2,QAG2/A,QAQ,QAQ4,QAQ4/A,QAR2,QAR2/A,QAW,QAW/A,QA2,QA2/A,QD,QD/A,QE,QE/A,QH,QH/A,QHB5,QHC,QHE,QHE4,QHE4/A,QHP1,QHP1/A,QHQ4,QHQ4/A,QHR,QHR/A,QHR4,QHR4/A,QHZ,QHZ/A,QH26,QH26/A,QKE3,QKE3/A,QKE4,QL2,QME2,QME2/A,QMH,QMH/A,QP,QP/A,QSC,QSC9,QSC9/A,QSE,QSE/A,QSE2,QSE8,QSE8/A,QT,QT/A,QWA2,QWA4,QWA4/A,QWH2,QWH2/A,QX,QX/A,QXB,QXB/A,QXB6,QXB6/A,QXB7,QXB7/A,QXC,QXC4,QXC4/A,QXC6,QXC6/A,QXC9,QXC9/A,QXE,QXE/A,QXEB,QXE4,QXE4/A,QXE6,QXE6/A,QXE8,QXE8/A,QXQ4,QXQ4/A,QXU,QXU/A,QX26,QX26/A,RA,RA2,RA2/A,RD,RD/A,RH,RHE,RHE4,RHE4/A,RHQ4,RHQ4/A,RH26,RH26/A,RSC2,RSC2/A,RSS,RSS/A,RX,RX/A,RXQ4,RXQ4/A,RXU,RXU/A,SD,SD/A,SE,SE/A,SH,SH/A,SHE,SHEZ,SHQ4,SHQ4/A,SJ,SJ/A,SJG,SJG/A,SJP,SK,SKE1,SMC4,SMC4/A,SMD,SME1,SME1/A,SME6,SME6/A,SMX2,SN,SN/A,SW,SWA4,SWC4,SWC4/A,SWE,SX,SX/A,SXB,SXB/A,SXB7,SXB7/A,SXE,SXE/A,SXEB,SXEB/A,SXE4,SXE4/A,SXE8,SXE8/A,SXQ4,SXQ4/A,SXU,SXU/A,SX2,VA,VAG2,VAG2/A,VAW,VAW1,VA2,VA2/A,VDE,VDE2,VDE2/A,VD16,VEB6,VH,VKE4,VKX4,VMA4,VME4,VMT,VMT/A,VMX2,VNG1,VNG1/A,VNT2,VNT2/A,VN17,VN17/A,VPE4,VPE7,VPE7/A,VPX4,VPX7,VPX7/A,VSD,VSD/A,VSD3,VSD3/A,VSD7,VSD7/A,VSH7,VS3,VS37,VS37/A,VWA,VWA2,VWA2/A,VWN2,VWN2/A,VWT4,VWT4/A,VW12,VW12/A,VW22,VX,VX/A,VXB,VXB/A,VXB2,VXB6,VXB7,VXE,VXEB,VXEB/A,VXE4,VXE4/A,VXE6,VXE6/A,VXE7,VXG,VXQ4,VXQ4/A,VXTB,VXT1,VXT1/A,VXU,VXU/A,VXU1,VXU1/A,VX26,WMA4,WMT8,WMT8/A,WXE8,WXE8/A

Ref. No.	Part No.	Description	Reqd. QTY			Serial No.	Parts catalogue code
			(1)	(2)	(3)		
(3)	16561-ZE2-000	SPRING, GOVERNOR	1	-	-	1304886	VME2
			1	-	-	1368686	VM2
			1	-	-	2134945	VPE4/A,VPX4/A,VXB7/A,VXE7/A
	16561-ZE2-800	(1)	-	(1)	-----	VD16,VNG1,VNG1/A,VN17,VN17/A,VPX4,VPX4/A,VPX7,VPX7/A,VSD,VSD/A,VSD3,VSD3/A,VSD7,VSD7/A,VS37,VS37/A,VX,VX/A,VXB,VXB/A,VXB2,VXB6,VXB7,VXB7/A,VXG,VXP,VXP/A,VXQP,VXQ4,VXQ4/A,VXTB,VXT1,VXT1/A,VXU,VXU/A,VXU1,VXU1/A,VX26
	16561-ZH9-U30	1	-	-	-----	VKB2,VKB2/A,VME2/A,VMS2,VM2/A
			1	-	-	1304887	VME2
			1	-	-	1368687	VM2
			1	-	-	2134946	VXB7/A,VXE7/A
	16561-ZK9-800	(1)	-	-	-----	VPE5,VPX5
			1	-	-	-----	VPE5,VPX5
			1	-	-	2134946	VPE4/A,VPX4/A
4	16562-ZE2-000	SPRING, THROTTLE RETURN	1	-	-	-----	ESS,ESS/A,ES1,ES1/A,ES3,ES3/A,HA,HAQ,HA2,HA2/A,HEA,HEA2,HEA2/A,HEA8,HEA8/A,HH,HX,HX/A,HXQ4,HXQ4/A,HX26,HX26/A,HX8,HX8/A,LH,LH/A,LHB1,LHB3,LHB5,LHE,LHE/A,LHQ4,LJ,LJ/A,LJC,LJC/A,LJG,LJG/A,LSS,LT,LT/A,LTJ,LW,LW/A,LWD1,LWD1/A,LX,LX/A,LXE,LXE/A,LXE8,LXE8/A,LXQ4,LXQ4/A,LXU,LXU/A,LXZ,LX16,PA,PAE2,PAE2/A,PA2,PA2/A,PX,PX/A,PXE8,PXE8/A,PXU,PXU/A,PX26,PX26/A,QA,QAB1,QAB3,QAB3/A,QAE,QAE2,QAE2/A,QAE6,QAE6/A,QAG,QAG/A,QAG2,QAG2/A,QAQ,QAQ4,QAQ4/A,QAR2,QAR2/A,QAW,QAW/A,QA2,QA2/A,QD,QD/A,QE,QE/A,QH,QH/A,QHB5,QHC,QHE,QHE4,QHE4/A,QHP1,QHP1/A,QHQ4,QHQ4/A,QHR,QHR/A,QHR4,QHR4/A,QHZ,QHZ/A,QH26,QH26/A,QKE3,QKE3/A,QKE4,QL2,QME2,QME2/A,QMH,QMH/A,QP,QP/A,QSC,QSC9,QSC9/A,QSE,QSE/A,QSE2,QSE8,QSE8/A,QT,QT/A,QWA2,QWA4,QWA4/A,QWH2,QWH2/A,QX,QX/A,QXB,QXB/A,QXB6,QXB6/A,QXB7,QXB7/A,QXC,QXC4,QXC4/A,QXC6,QXC6/A,QXC9,QXC9/A,QXE,QXE/A,QXEB,QXE4,QXE4/A,QXE6,QXE6/A,QXE8,QXE8/A,QXQ4,QXQ4/A,QXU,QXU/A,QX26,QX26/A,RA,RA2,RA2/A,RD,RD/A,RH,RHE,RHE4,RHE4/A,RHQ4,RHQ4/A,RH26,RH26/A,RSC2,RSC2/A,RSS,RSS/A,RX,RX/A,RXQ4,RXQ4/A,RXU,RXU/A,SD,SD/A,SE,SE/A,SH,SH/A,SHE,SHEZ,SHQ4,SHQ4/A,SJ,SJ/A,SJG,SJG/A,SJP,SK,SKE1,SMC4,SMC4/A,SMD,SME1,SME1/A,SME6,SME6/A,SMX2,SN,SN/A,SW,SWA4,SWC4,SWC4/A,SWE,SX,SX/A,SXB,SXB/A,SXB7,SXB7/A,SXE,SXE/A,SXEB,SXEB/A,SXE4,SXE4/A,SXE8,SXE8/A,SXQ4,SXQ4/A,SXU,SXU/A,SX2,VA,VAW,VAW1,VA2,VA2/A,VDE,VDE2,VDE2/A,VD16,VEB6,VH,VKE4,VKX4,VMA4,VME2,VME2/A,VME4,VM2,VM2/A,VNG1,VNG1/A,VNT2,VNT2/A,VN17,VN17/A,VPE4,VPE4/A,VPE5,VPE7,VPE7/A,VPX4,VPX4/A,VPX5,VPX7,VPX7/A,VSD,VSD/A,VSD3,VSD3/A,VSD7,VSD7/A,VSH7,VS3,VS37,VS37/A,VWN2,VWN2/A,VWT4,VWT4/A,VW12,VW12/A,VW22,VX,VX/A,VXB,VXB/A,VXB2,VXB6,VXB7,VXB7/A,VXE,VXEB,VXEB/A,VXE4,VXE4/A,VXE6,VXE6/A,VXE7,VXE7/A,VXG,VXQ4,VXQ4/A,VXTB,VXT1,VXT1/A,VXU,VXU/A,VXU1,VXU1/A,VX26,WMA4,WMT8,WMT8/A,WXE8,WXE8/A
			-	1	1		
	16562-ZE2-700	1	-	-	-----	VAG2,VAG2/A,VKB2,VKB2/A,VMS2,VMT,VMT/A,VMX2,VWA,VWA2,VWA2/A
5	16570-ZE2-W00	CONTROL ASSY.	1	-	1	-----	HA,HAP,HAP/A,HAQ,HA2,HA2/A,HEA,HEA2,HEA2/A,HEA8,HEA8/A,HH,HX,HX/A,HXQ4,HXQ4/A,HX26,HX26/A,HX8,HX8/A,PA,PA2,PA2/A,PX,PX/A,PXU,PXU/A,PX26,PX26/A,QD,QD/A,RD,RD/A,SD,SD/A,SMC4,SMC4/A,SMD,SN,SN/A,VD16,VEB6,VH,VX,VX/A,VXB,VXB/A,VXB2,VXB6,VXB7,VXB7/A,VXE,VXEB,VXEB/A,VXE4,VXE4/A,VXE6,VXE6/A,VXE7,VXE7/A,VXP,VXP/A,VXQP,VXQ4,VXQ4/A,VXTB,VX26,WMA4,WMT8,WMT8/A,WXE8,WXE8/A
			-	(1)	-		
	16570-ZE2-W40	1	-	-	-----	VNG1,VNG1/A,VN17,VN17/A
			-	(1)	-		
6	16570-ZE2-W10	CONTROL ASSY. (REMOTE)	1	-	-	-----	LJ,LJ/A,LJC,LJC/A,LJG,LJG/A,LSS,LT,LT/A,LTJ,LWD1,LWD1/A,QKE3,QKE3/A,QKE4,SJ,SJ/A,SJG,SJG/A,SK,SKE1,SME6,SME6/A,VMA4,VM4
			1	-	-	2302563	SMX2
			-	(1)	-		



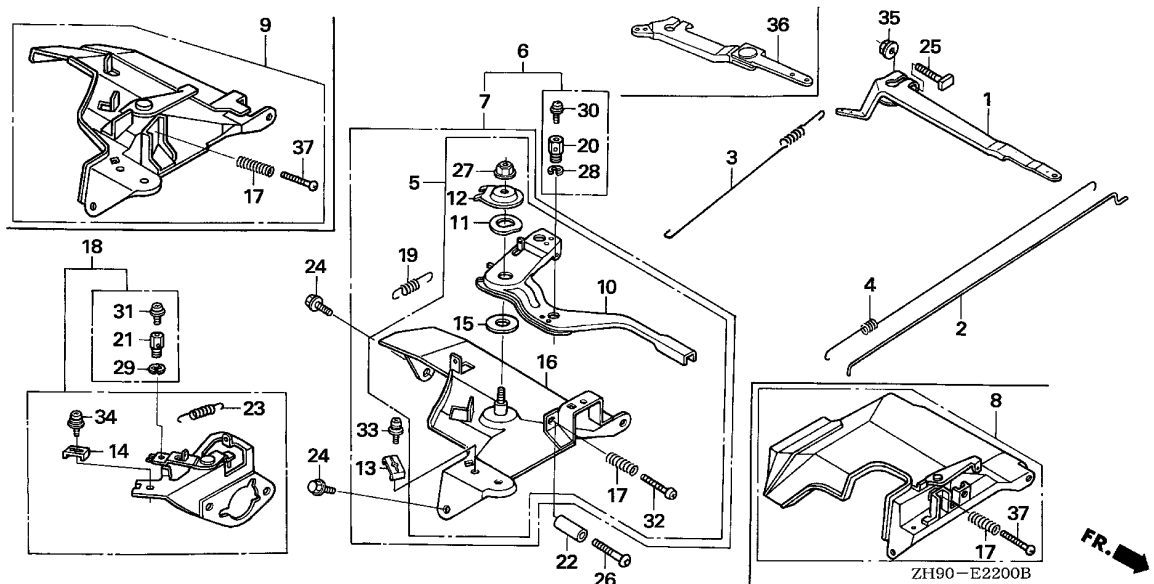

Ref. No.	Part No.	Description	Reqd. QTY			Serial No.	Parts catalogue code	
			(1)	(2)	(3)			
(6)	16570-ZE2-W50	CONTROL ASSY. (REMOTE)	1	-	-	----- SJP		
			1	-	-	----- 2302564	SMX2	
7	16570-ZE2-W20	CONTROL ASSY. (REMOTE)	1	-	1	-----	LH,LH/A,LHB1,LHB3,LHB5,LHE,LHE/A,LHQ4,LW,LW/A,LX,LX/A,LXE,LXE/A LXE8,LXE8/A,LXQ4,LXQ4/A,LXU,LXU/A,LXZ,LX16,PAE2,PAE2/A,PXE8 PXE8/A,QA,QAB1,QAB3,QAB3/A,QAE,QAE2,QAE2/A,QAE6,QAE6/A,QAG,QAG/A QAG2,QAG2/A,QAQ,QAQ4,QAQ4/A,QAR2,QAR2/A,QAW,QAW/A,QA2,QA2/A,QE QE/A,QH,QH/A,QHB5,QHC,QHE,QHE4,QHE4/A,QHP1,QHP1/A,QHQ4,QHQ4/A,QHR QHR/A,QHR4,QHR4/A,QHZ,QHZ/A,QH26,QH26/A,QL2,QME2,QME2/A,QMH,QMH/A QP,QP/A,QSC,QSC9,QSC9/A,QSE,QSE/A,QSE2,QSE8,QSE8/A,QT,QT/A,QWA2 QWA4,QWA4/A,QWH2,QWH2/A,QX,QX/A,QXB,QXB/A,QXB6,QXB6/A,QXB7,QXB7/A QXC,QXC4,QXC4/A,QXC6,QXC6/A,QXC9,QXC9/A,QXE,QXE/A,QXEB,QXE4 QXE4/A,QXE6,QXE6/A,QXE8,QXE8/A,QXQ4,QXQ4/A,QXU,QXU/A,QX26,QX26/A RA,RA2,RA2/A,RH,RHE,RHE4,RHE4/A,RHQ4,RHQ4/A,RH26,RH26/A,RSC2 RSC2/A,RSS,RSS/A,RX,RX/A,RXP,RXP/A,RXQ4,RXQ4/A,RXU,RXU/A,SE,SE/A SH,SH/A,SHE,SHEZ,SHQ4,SHQ4/A,SME1,SME1/A,SW,SWA4,SWC4,SWC4/A,SWE SX,SX/A,SXB,SXB/A,SXB7,SXB7/A,SXE,SXE/A,SXEB,SXEB/A,SXE4,SXE4/A SXEB,SXEB/A,SXQ4,SXQ4/A,SXU,SXU/A,SX2,VA,VAW,VA2,VA2/A,VDE,VDE2 VDE2/A,VME2,VME2/A,VM2,VM2/A,VWN2,VWN2/A	
8	16570-ZE2-701	CONTROL ASSY.	1	(1)	-	-----	ES3,ES3/A,VKE4,VKX4,VMT,VMT/A,VPE4,VPE4/A,VPE5,VPE7,VPE7/A,VPX4 VPX4/A,VPX5,VPX7,VPX7/A,VSD3,VSD3/A,VS3,VS37,VS37/A	
9	16570-ZE2-721	CONTROL ASSY.	1	-	-	-----	ES1,ES1/A,VAG2,VAG2/A,VAW1,VKB2,VKB2/A,VMS2,VMX2,VNT2,VNT2/A,VSD VSD/A,VSD7,VSD7/A,VSH7,VWA,VWA2,VWA2/A,VWT4,VWT4/A,VW12,VW12/A VW22,VXG,VXT1,VXT1/A,VXU,VXU/A,VXU1,VXU1/A	

2

Ref. No.	Part No.	Description	Reqd. QTY			Serial No.	Parts catalogue code
			(1)	(2)	(3)		
10	16571-ZE2-W00	LEVER, CONTROL	1	-	-	HA,HAQ,HA2,HA2/A,HEA,HEA2,HEA2/A,HEA8,HEA8/A,HH,HX,HX/A,HXQ4 HXQ4/A,HX26,HX26/A,HX8,HX8/A,LH,LH/A,LHB1,LHB3,LHB5,LHE,LHE/A LHQ4,LJ,LJ/A,LJC,LJC/A,LJG,LJG/A,LSS,LT,LT/A,LTJ,LW,LW/A,LWD1 LWD1/A,LX,LX/A,LXE,LXE/A,LXE8,LXE8/A,LXQ4,LXQ4/A,LXU,LXU/A,LXZ LX16,PA,PAE2,PAE2/A,PA2,PA2/A,PX,PX/A,PXE8,PXE8/A,PXU,PXU/A,PX26 PX26/A,QA,QAB1,QAB3,QAB3/A,QAE,QAE2,QAE2/A,QAE6,QAE6/A,QAG,QAG/A QAG2,QAG2/A,QAQ,QAQ4,QAQ4/A,QAR2,QAR2/A,QAW,QAW/A,QA2,QA2/A,QD QD/A,QE,QE/A,QH,QH/A,QHB5,QHC,QHE,QHE4,QHE4/A,QHP1,QHP1/A,QHQ4 QHQ4/A,QHR,QHR/A,QHR4,QHR4/A,QHZ,QHZ/A,QH26,QH26/A,QKE3,QKE3/A QKE4,QL2,QME2,QME2/A,QMH,QMH/A,QP,QP/A,QSC,QSC9,QSC9/A,QSE,QSE/A QSE2,QSE8,QSE8/A,QT,QT/A,QWA2,QWA4,QWA4/A,QWH2,QWH2/A,QX,QX/A,QXB QXB/A,QXB6,QXB6/A,QXB7,QXB7/A,QXC,QXC4,QXC4/A,QXC6,QXC6/A,QXC9 QXC9/A,QXE,QXE/A,QXEB,QXE4,QXE4/A,QXE6,QXE6/A,QXE8,QXE8/A,QXQ4 QXQ4/A,QXU,QXU/A,QX26,QX26/A,RA,RA2,RA2/A,RD,RD/A,RH,RHE,RHE4 RHE4/A,RHQ4,RHQ4/A,RH26,RH26/A,RSC2,RSC2/A,RSS,RSS/A,RX,RX/A,RXQ4 RXQ4/A,RXU,RXU/A,SD,SD/A,SE,SE/A,SH,SH/A,SHE,SHEZ,SHQ4,SHQ4/A,SJ SJ/A,SJG,SJG/A,SJP,SK,SKE1,SMC4,SMC4/A,SMD,SME1,SME1/A,SME6 SME6/A,SMX2,SN,SN/A,SW,SWA4,SWC4,SWC4/A,SWE,SX,SX/A,AXB,AXB/A AXB7,AXB7/A,SXE,SXE/A,SXEB,SXEB/A,SXE4,SXE4/A,SXE8,SXE8/A,SXQ4 SXQ4/A,SXU,SXU/A,SX2,VA,VAW,VA2,VA2/A,VDE,VDE2,VDE2/A,VD16,VEB6 VH,VMA4,VME2,VME2/A,VME4,VM2,VM2/A,VWN2,VWN2/A,VX,VX/A,VXB,VXB/A VXB2,VXB6,VXB7,VXB7/A,VXE,VXEB,VXEB/A,VXE4,VXE4/A,VXE6,VXE6/A VXE7,VXE7/A,VXQ4,VXQ4/A,VXTB,VX26,WMA4,WMT8,WMT8/A,WXE8,WXE8/A	
	16571-ZE2-W10 (16570-ZE2-W40)	-	(1)	1	Q2,VNG1,VNG1/A,VN17,VN17/A	
			-	(1)	-	L1,L1/A,Q1,Q1/A,R1,R1/A,S1,S1/A,V1,W1,W1/A	
11	16574-ZE1-000	SPRING, LEVER	1	-	-	HA,HAQ,HA2,HA2/A,HEA,HEA2,HEA2/A,HEA8,HEA8/A,HH,HX,HX/A,HXQ4 HXQ4/A,HX26,HX26/A,HX8,HX8/A,LH,LH/A,LHB1,LHB3,LHB5,LHE,LHE/A LHQ4,LJ,LJ/A,LJC,LJC/A,LJG,LJG/A,LSS,LT,LT/A,LTJ,LW,LW/A,LWD1 LWD1/A,LX,LX/A,LXE,LXE/A,LXE8,LXE8/A,LXQ4,LXQ4/A,LXU,LXU/A,LXZ LX16,PA,PAE2,PAE2/A,PA2,PA2/A,PX,PX/A,PXE8,PXE8/A,PXU,PXU/A,PX26 PX26/A,QA,QAB1,QAB3,QAB3/A,QAE,QAE2,QAE2/A,QAE6,QAE6/A,QAG,QAG/A QAG2,QAG2/A,QAQ,QAQ4,QAQ4/A,QAR2,QAR2/A,QAW,QAW/A,QA2,QA2/A,QD QD/A,QE,QE/A,QH,QH/A,QHB5,QHC,QHE,QHE4,QHE4/A,QHP1,QHP1/A,QHQ4 QHQ4/A,QHR,QHR/A,QHR4,QHR4/A,QHZ,QHZ/A,QH26,QH26/A,QKE3,QKE3/A QKE4,QL2,QME2,QME2/A,QMH,QMH/A,QP,QP/A,QSC,QSC9,QSC9/A,QSE,QSE/A QSE2,QSE8,QSE8/A,QT,QT/A,QWA2,QWA4,QWA4/A,QWH2,QWH2/A,QX,QX/A,QXB QXB/A,QXB6,QXB6/A,QXB7,QXB7/A,QXC,QXC4,QXC4/A,QXC6,QXC6/A,QXC9 QXC9/A,QXE,QXE/A,QXEB,QXE4,QXE4/A,QXE6,QXE6/A,QXE8,QXE8/A,QXQ4 QXQ4/A,QXU,QXU/A,QX26,QX26/A,RA,RA2,RA2/A,RD,RD/A,RH,RHE,RHE4 RHE4/A,RHQ4,RHQ4/A,RH26,RH26/A,RSC2,RSC2/A,RSS,RSS/A,RX,RX/A,RXQ4 RXQ4/A,RXU,RXU/A,SD,SD/A,SE,SE/A,SH,SH/A,SHE,SHEZ,SHQ4,SHQ4/A,SJ SJ/A,SJG,SJG/A,SJP,SK,SKE1,SMC4,SMC4/A,SMD,SME1,SME1/A,SME6 SME6/A,SMX2,SN,SN/A,SW,SWA4,SWC4,SWC4/A,SWE,SX,SX/A,AXB,AXB/A AXB7,AXB7/A,SXE,SXE/A,SXEB,SXEB/A,SXE4,SXE4/A,SXE8,SXE8/A,SXQ4 SXQ4/A,SXU,SXU/A,SX2,VA,VAW,VA2,VA2/A,VDE,VDE2,VDE2/A,VD16,VEB6 VH,VMA4,VME2,VME2/A,VME4,VM2,VM2/A,VNG1,VNG1/A,VN17,VN17/A,VWN2 VWN2/A,VX,VX/A,VXB,VXB/A,VXB2,VXB6,VXB7,VXB7/A,VXE,VXEB,VXEB/A VXE4,VXE4/A,VXE6,VXE6/A,VXE7,VXE7/A,VXQ4,VXQ4/A,VXTB,VX26,WMA4 WMT8,WMT8/A,WXE8,WXE8/A	
			-	(1)	1		



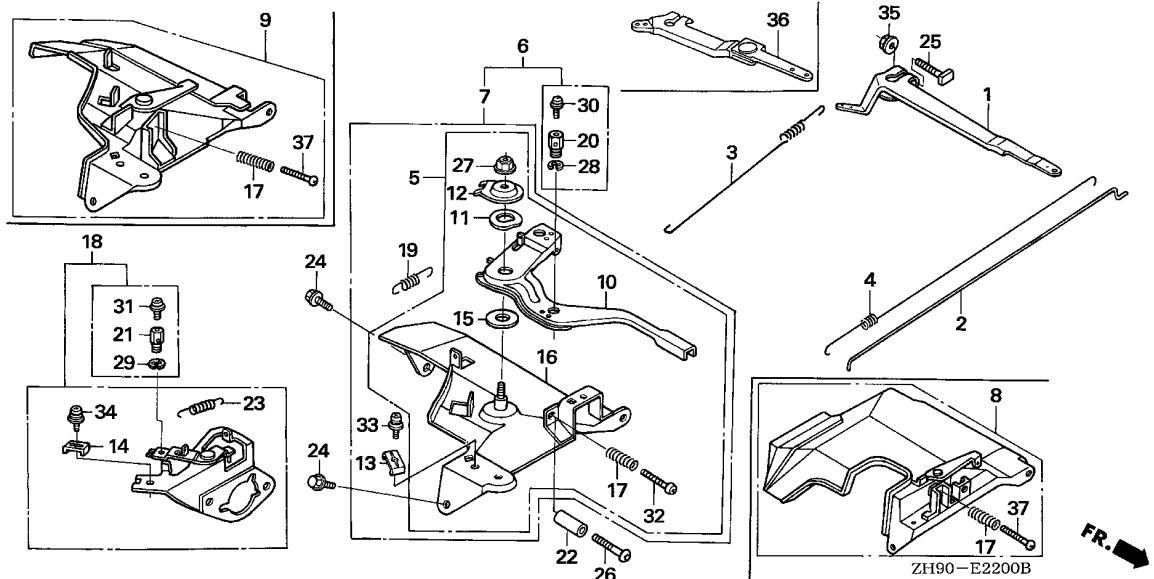

Ref. No.	Part No.	Description	Reqd. QTY			Serial No.	Parts catalogue code		
			(1)	(2)	(3)				
12	16575-ZE2-W00	WASHER, CONTROL LEVER	1	-	-	HA,HAQ,HA2,HA2/A,HEA,HEA2,HEA2/A,HEA8,HEA8/A,HH,HX,HX/A,HXQ4,HXQ4/A,HX26,HX26/A,HX8,HX8/A,LH,LH/A,LHB1,LHB3,LHB5,LHE,LHE/A,LHQ4,LJ,LJ/A,LJC,LJC/A,LJG,LJG/A,LSS,LT,LT/A,LTJ,LW,LW/A,LWD1,LWD1/A,LX,LX/A,LXE,LXE/A,LXE8,LXE8/A,LXQ4,LXQ4/A,LXU,LXU/A,LXZ,LX16,PA,PAE2,PAE2/A,PA2,PA2/A,PX,PX/A,PXE8,PXE8/A,PXU,PXU/A,PX26,PX26/A,QA,QAB1,QAB3,QAB3/A,QAE,QAE2,QAE2/A,QAE6,QAE6/A,QAG,QAG/A,QAG2,QAG2/A,QAQ,QAQ4,QAQ4/A,QAR2,QAR2/A,QAW,QAW/A,QA2,QA2/A,QD,QD/A,QE,QE/A,QH,QH/A,QHB5,QHC,QHE,QHE4,QHE4/A,QHP1,QHP1/A,QHQ4,QHQ4/A,QHR,QHR/A,QHR4,QHR4/A,QHZ,QHZ/A,QH26,QH26/A,QKE3,QKE3/A,QKE4,QL2,QME2,QME2/A,QMH,QMH/A,QP,QP/A,QSC,QSC9,QSC9/A,QSE,QSE/A,QSE2,QSE8,QSE8/A,QT,QT/A,QWA2,QWA4,QWA4/A,QWH2,QWH2/A,QX,QX/A,QXB,QXB/A,QXB6,QXB6/A,QXB7,QXB7/A,QXC,QXC4,QXC4/A,QXC6,QXC6/A,QXC9,QXC9/A,QXE,QXE/A,QXEB,QXE4,QXE4/A,QXE6,QXE6/A,QXE8,QXE8/A,QXQ4,QXQ4/A,QXU,QXU/A,QX26,QX26/A,RA,RA2,RA2/A,RD,RD/A,RH,RHE,RHE4,RHE4/A,RHQ4,RHQ4/A,RH26,RH26/A,RSC2,RSC2/A,RSS,RSS/A,RX,RX/A,RXQ4,RXQ4/A,RXU,RXU/A,SD,SD/A,SE,SE/A,SH,SH/A,SHE,SHEZ,SHQ4,SHQ4/A,SJ,SJ/A,SJG,SJG/A,SJP,SK,SKE1,SMC4,SMC4/A,SMD,SME1,SME1/A,SME6,SME6/A,SMX2,SN,SN/A,SW,SWA4,SWC4,SWC4/A,SWE,SX,SX/A,SXB,SXB/A,SXB7,SXB7/A,SXE,SXE/A,SXEB,SXEB/A,SXE4,SXE4/A,SXE8,SXE8/A,SXQ4,SXQ4/A,SXU,SXU/A,SX2,VA,VAW,VA2,VA2/A,VDE,VDE2,VDE2/A,VD16,VEB6,VH,VMA4,VME2,VME2/A,VME4,VM2,VM2/A,VNG1,VNG1/A,VN17,VN17/A,VWN2,VWN2/A,VX,VX/A,VXB,VXB/A,VXB2,VXB6,VXB7,VXB7/A,VXE,VXEB,VXEB/A,VXE4,VXE4/A,VXE6,VXE6/A,VXE7,VXE7/A,VXQ4,VXQ4/A,VXTB,VX26,WMA4,WMT8,WMT8/A,WXE8,WXE8/A	-	(1)	1

Ref. No.	Part No.	Description	Reqd. QTY			Serial No.	Parts catalogue code
			(1)	(2)	(3)		
13	16576-891-000	HOLDER, CABLE	1	-	1	-----	LH,LH/A,LHB1,LHB3,LHB5,LHE,LHE/A,LHQ4,LJ,LJ/A,LJC,LJC/A,LJG,LJG/A,LSS,LT,LT/A,LTJ,LW,LW/A,LWD1,LWD1/A,LX,LX/A,LXE,LXE/A,LXE8,LXE8/A,LXQ4,LXQ4/A,LXU,LXU/A,LXZ,LX16,PAE2,PAE2/A,PXE8,PXE8/A,QA,QAB1,QAB3,QAB3/A,QAE,QAE2,QAE2/A,QAE6,QAE6/A,QAG,QAG/A,QAG2,QAG2/A,QAQ,QAQ4,QAQ4/A,QAR2,QAR2/A,QAW,QAW/A,QA2,QA2/A,QE,QE/A,QH,QH/A,QHB5,QHC,QHE,QHE4,QHE4/A,QHP1,QHP1/A,QHQ4,QHQ4/A,QHR,QHR/A,QHR4,QHR4/A,QHZ,QHZ/A,QH26,QH26/A,QKE3,QKE3/A,QKE4,QL2,QME2,QME2/A,QMH,QMH/A,QP,QP/A,QSC,QSC9,QSC9/A,QSE,QSE/A,QSE2,QSE8,QSE8/A,QT,QT/A,QWA2,QWA4,QWA4/A,QWH2,QWH2/A,QX,QX/A,QXB,QXB/A,QXB6,QXB6/A,QXB7,QXB7/A,QXC,QXC4,QXC4/A,QXC6,QXC6/A,QXC9,QXC9/A,QXE,QXE/A,QXE6,QXE6/A,QXE8,QXE8/A,QXQ4,QXQ4/A,QXU,QXU/A,QX26,QX26/A,RA,RA2,RA2/A,RH,RHE,RHE4,RHE4/A,RHQ4,RHQ4/A,RH26,RH26/A,RSC2,RSC2/A,RSS,RSS/A,RX,RX/A,RXP,RXP/A,RXQ4,RXQ4/A,RXU,RXU/A,SE,SE/A,SH,SH/A,SHE,SHEZ,SHQ4,SHQ4/A,SJ,SJ/A,SJG,SJG/A,SJP,SK,SKE1,SME1,SME1/A,SME6,SME6/A,SMX2,SW,SWA4,SWC4,SWC4/A,SWE,SX,SX/A,SBX,SBX/A,SBX7,SBX7/A,SXE,SXE/A,SXEB,SXEB/A,SXE4,SXE4/A,SXE8,SXE8/A,SXQ4,SXQ4/A,SXU,SXU/A,SX2,VA,VAW,VA2,VA2/A,VDE,VDE2,VDE2/A,VMA4,VME2,VME2/A,VME4,VM2,VM2/A,VWN2,VWN2/A
			-	(1)	-		
14	16576-891-000	HOLDER, CABLE	1	-	-	-----	LTJ,LWD1,LWD1/A,QKE3,QKE3/A,QKE4,QME2,QME2/A,SKE1
			-	(1)	-		
15	16578-ZE1-000	SPACER, CONTROL LEVER	1	-	-	-----	HA,HAQ,HA2,HA2/A,HEA,HEA2,HEA2/A,HEA8,HEA8/A,HH,HX,HX/A,HXQ4,HXQ4/A,HX26,HX26/A,HX8,HX8/A,LH,LH/A,LHB1,LHB3,LHB5,LHE,LHE/A,LHQ4,LJ,LJ/A,LJC,LJC/A,LJG,LJG/A,LSS,LT,LT/A,LTJ,LW,LW/A,LWD1,LWD1/A,LX,LX/A,LXE,LXE/A,LXE8,LXE8/A,LXQ4,LXQ4/A,LXU,LXU/A,LXZ,LX16,PA,PAE2,PAE2/A,PA2,PA2/A,PX,PX/A,PXE8,PXE8/A,PXU,PXU/A,PX26,PX26/A,QA,QAB1,QAB3,QAB3/A,QAE,QAE2,QAE2/A,QAE6,QAE6/A,QAG,QAG/A,QAG2,QAG2/A,QAQ,QAQ4,QAQ4/A,QAR2,QAR2/A,QAW,QAW/A,QA2,QA2/A,QD,QD/A,QE,QE/A,QH,QH/A,QHB5,QHC,QHE,QHE4,QHE4/A,QHP1,QHP1/A,QHQ4,QHQ4/A,QHR,QHR/A,QHR4,QHR4/A,QHZ,QHZ/A,QH26,QH26/A,QKE3,QKE3/A,QKE4,QL2,QME2,QME2/A,QMH,QMH/A,QP,QP/A,QSC,QSC9,QSC9/A,QSE,QSE/A,QSE2,QSE8,QSE8/A,QT,QT/A,QWA2,QWA4,QWA4/A,QWH2,QWH2/A,QX,QX/A,QXB,QXB/A,QXB6,QXB6/A,QXB7,QXB7/A,QXC,QXC4,QXC4/A,QXC6,QXC6/A,QXC9,QXC9/A,QXE,QXE/A,QXE6,QXE6/A,QXE8,QXE8/A,QXQ4,QXQ4/A,QXU,QXU/A,QX26,QX26/A,RA,RA2,RA2/A,RD,RD/A,RH,RHE,RHE4,RHE4/A,RHQ4,RHQ4/A,RH26,RH26/A,RSC2,RSC2/A,RSS,RSS/A,RX,RX/A,RXQ4,RXQ4/A,RXU,RXU/A,SD,SD/A,SE,SE/A,SH,SH/A,SHE,SHEZ,SHQ4,SHQ4/A,SJ,SJ/A,SJG,SJG/A,SJP,SK,SKE1,SMC4,SMC4/A,SMD,SME1,SME1/A,SME6,SME6/A,SMX2,SN,SN/A,SW,SWA4,SWC4,SWC4/A,SWE,SX,SX/A,SBX,SBX/A,SBX7,SBX7/A,SXE,SXE/A,SXEB,SXEB/A,SXE4,SXE4/A,SXE8,SXE8/A,SXQ4,SXQ4/A,SXU,SXU/A,SX2,VA,VAW,VA2,VA2/A,VDE,VDE2,VDE2/A,VD16,VEB6,VH,VMA4,VME2,VME2/A,VME4,VM2,VM2/A,VNG1,VNG1/A,VN17,VN17/A,VWN2,VWN2/A,VX,VX/A,VXB,VXB/A,VXB2,VXB2,VXB7,VXB7/A,VXE,VXE8,VXE8/A,VXE4,VXE4/A,VXE6,VXE6/A,VXE7,VXE7/A,VXQ4,VXQ4/A,VXTB,VX26,WMA4,WMT8,WMT8/A,WXE8,WXE8/A
			-	(1)	1		



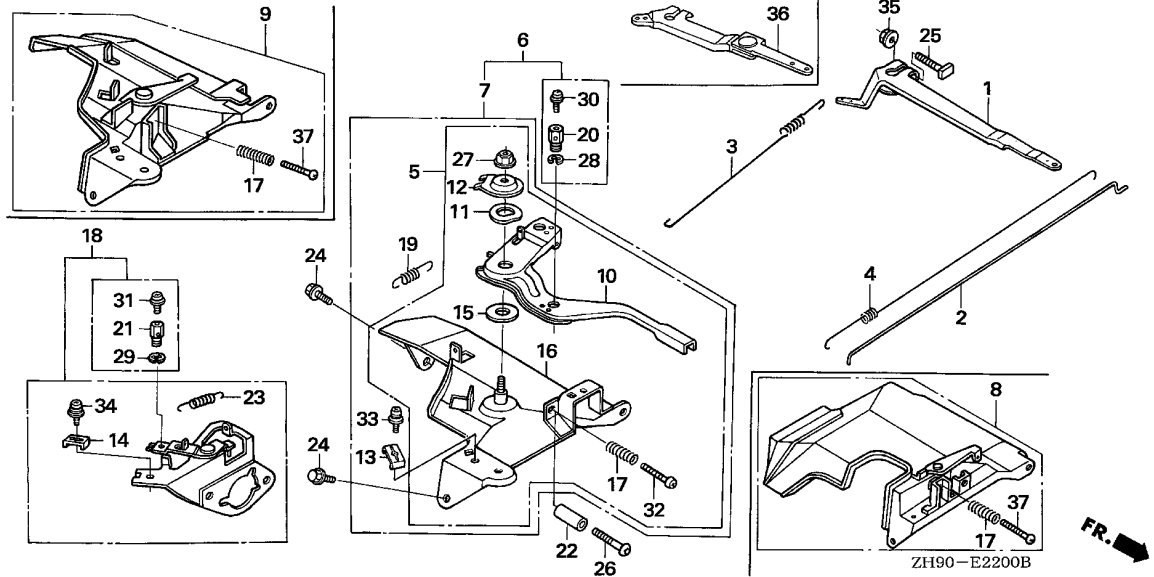

Ref. No.	Part No.	Description	Reqd. QTY			Serial No.	Parts catalogue code
			(1)	(2)	(3)		
16	16581-ZE2-W00	BASE COMP., CONTROL (###) ...	1	-	-	-----	HA,HAQ,HA2,HA2/A,HEA,HEA2,HEA2/A,HEA8,HEA8/A,HH,HX,HX/A,HXQ4 HXQ4/A,HX26,HX26/A,HX8,HX8/A,LH,LH/A,LHB1,LHB3,LHB5,LHE,LHE/A LHQ4,LJ,LJ/A,LJC,LJC/A,LJG,LJG/A,LSS,LT,LT/A,LTJ,LW,LW/A,LWD1 LWD1/A,LX,LX/A,LXE,LXE/A,LXE8,LXE8/A,LXQ4,LXQ4/A,LXU,LXU/A,LXZ LX16,PA,PAE2,PAE2/A,PA2,PA2/A,PX,PX/A,PXE8,PXE8/A,PXU,PXU/A,PX26 PX26/A,QA,QAB1,QAB3,QAB3/A,QAE,QAE2,QAE2/A,QAE6,QAE6/A,QAG,QAG/A QAG2,QAG2/A,QAQ,QAQ4,QAQ4/A,QAR2,QAR2/A,QAW,QAW/A,QA2,QA2/A,QD QD/A,QE,QE/A,QH,QH/A,QHB5,QHC,QHE,QHE4,QHE4/A,QHP1,QHP1/A,QHQ4 QHQ4/A,QHR,QHR/A,QHR4,QHR4/A,QHZ,QHZ/A,QH26,QH26/A,QKE3,QKE3/A QL2,QME2,QME2/A,QMH,QMH/A,QP,QP/A,QSC,QSC9,QSC9/A,QSE,QSE/A,QSE2 QSE8,QSE8/A,QT,QT/A,QWA2,QWA4,QWA4/A,QWH2,QWH2/A,QX,QX/A,QXB QXB/A,QXB6,QXB6/A,QXB7,QXB7/A,QXC,QXC4,QXC4/A,QXC6,QXC6/A,QXC9 QXC9/A,QXE,QXE/A,QXEB,QXE4,QXE4/A,QXE6,QXE6/A,QXE8,QXE8/A,QXQ4 QXQ4/A,QXU,QXU/A,QX26,QX26/A,RA,RA2,RA2/A,RD,RD/A,RH,RHE,RHE4 RHE4/A,RHQ4,RHQ4/A,RH26,RH26/A,RSC2,RSC2/A,RSS,RSS/A,RX,RX/A,RXQ4 RXQ4/A,RXU,RXU/A,SD,SD/A,SE,SE/A,SH,SH/A,SHE,SHEZ,SHQ4,SHQ4/A,SJ SJ/A,SJG,SJG/A,SJP,SK,SKE1,SMC4,SMC4/A,SMD,SME1,SME1/A,SME6 SME6/A,SMX2,SN,SN/A,SW,SWA4,SWC4,SWC4/A,SWE,SX,SX/A,SXB,SXB/A SXB7,SXB7/A,SXE,SXE/A,SXEB,SXEB/A,SXE4,SXE4/A,SXE8,SXE8/A, SXQ4 SXQ4/A,SXU,SXU/A,SX2,VA,VAW,VA2,VA2/A,VDE,VDE2,VDE2/A,VD16,VEB6 VH,VMA4,VME2,VME2/A,VME4,VM2,VM2/A,VNG1,VNG1/A,VN17,VN17/A,VWN2 VWN2/A,VX,VX/A,VXB,VXB/A,VXB2,VXB6,VXB7,VXB7/A,VXE,VXEB,VXEB/A VXE4,VXE4/A,VXE6,VXE6/A,VXE7,VXE7/A,VXQ4,VXQ4/A,VXTB,VX26,WMA4 WMT8,WMT8/A,WXE8,WXE8/A
			-	(1)	1		

2

Ref. No.	Part No.	Description	Reqd. QTY			Serial No.	Parts catalogue code
			(1)	(2)	(3)		
17	16584-883-300	SPRING, CONTROL ADJUSTING ...	1	-	-	-----	ES1,ES1/A,ES3,ES3/A,HA,HAQ,HA2,HA2/A,HEA,HEA2,HEA2/A,HEA8,HEA8/A,HH,HX,HX/A,HXQ4,HXQ4/A,HX26,HX26/A,HX8,HX8/A,LH,LH/A,LHB1,LHB3,LHB5,LHE,LHE/A,LHQ4,LJ,LJ/A,LJC,LJC/A,LJG,LJG/A,LSS,LT,LT/A,LTJ,LW,LW/A,LWD1,LWD1/A,LX,LX/A,LXE,LXE/A,LXE8,LXE8/A,LXQ4,LXQ4/A,LXU,LXU/A,LXZ,LX16,PA,PAE2,PAE2/A,PA2,PA2/A,PX,PX/A,PXE8,PXE8/A,PXU,PXU/A,PX26,PX26/A,QA,QAB1,QAB3,QAB3/A,QAE,QAE2,QAE2/A,QAE6,QAE6/A,QAG,QAG/A,QAG2,QAG2/A,QAQ,QAQ4,QAQ4/A,QAR2,QAR2/A,QAW,QAW/A,QA2,QA2/A,QD,QD/A,QE,QE/A,QH,QH/A,QHB5,QHC,QHE,QHE4,QHE4/A,QHP1,QHP1/A,QHQ4,QHQ4/A,QHR,QHR/A,QHR4,QHR4/A,QHZ,QHZ/A,QH26,QH26/A,QKE3,QKE3/A,QKE4,QL2,QME2,QME2/A,QMH,QMH/A,QP,QP/A,QSC,QSC9,QSC9/A,QSE,QSE/A,QSE2,QSE8,QSE8/A,QT,QT/A,QWA2,QWA4,QWA4/A,QWH2,QWH2/A,QX,QX/A,QXB,QXB/A,QXB6,QXB6/A,QXB7,QXB7/A,QXC,QXC4,QXC4/A,QXC6,QXC6/A,QXC9,QXC9/A,QXE,QXE/A,QXEB,QXE4,QXE4/A,QXE6,QXE6/A,QXE8,QXE8/A,QXQ4,QXQ4/A,QXU,QXU/A,QX26,QX26/A,RA,RA2,RA2/A,RD,RD/A,RH,RHE,RHE4,RHE4/A,RHQ4,RHQ4/A,RH26,RH26/A,RSC2,RSC2/A,RSS,RSS/A,RX,RX/A,RXQ4,RXQ4/A,RXU,RXU/A,SD,SD/A,SE,SE/A,SH,SH/A,SHE,SHEZ,SHQ4,SHQ4/A,SJ,SJ/A,SJG,SJG/A,SJP,SK,SKE1,SMC4,SMC4/A,SMD,SME1,SME1/A,SME6,SME6/A,SMX2,SN,SN/A,SW,SWA4,SWC4,SWC4/A,SWE,SX,SX/A,SXB,SXB/A,SXB7,SXB7/A,SXE,SXE/A,SXEB,SXEB/A,SXE4,SXE4/A,SXE8,SXE8/A,SXQ4,SXQ4/A,SXU,SXU/A,SX2,VA,VAG2,VAG2/A,VAW,VAW1,VA2,VA2/A,VDE,VDE2,VDE2/A,VD16,VEB6,VH,VKB2,VKB2/A,VKE4,VKX4,VMA4,VME2,VME2/A,VME4,VMS2,VMT,VMT/A,VMX2,VM2,VM2/A,VNG1,VNG1/A,VNT2,VNT2/A,VN17,VN17/A,VPE4,VPE4/A,VPE5,VPE7,VPE7/A,VPX4,VPX4/A,VPX5,VPX7,VPX7/A,VSD,VSD/A,VSD3,VSD3/A,VSD7,VSD7/A,VSH7,VS3,VS37/VSA,VWA,VWA2,VWA2/A,VWN2,VWN2/A,VWT4,VWT4/A,VW12,VW12/A,VW22,VX,VX/A,VXB,VXB/A,VXB2,VXB6,VXB7,VXB7/A,VXE,VXEB,VXEB/A,VXE4,VXE4/A,VXE6,VXE6/A,VXE7,VXE7/A,VXG,VXQ4,VXQ4/A,VXTB,VXT1/VXT1/A,VXU,VXU/A,VXU1,VXU1/A,VX26,WMA4,WMT8,WMT8/A,WXE8,WXE8/A
18	16590-ZE2-812	STAY ASSY., CHOKE CONTROL (REMOTE)	1	-	-	-----	LTJ,LWD1,LWD1/A,QKE3,QKE3/A,QKE4,QME2,QME2/A,SKE1
19	16592-883-310	SPRING, CABLE RETURN	1	-	1	-----	LH,LH/A,LHB1,LHB3,LHB5,LHE,LHE/A,LHQ4,LJ,LJ/A,LJC,LJC/A,LJG,LJG/A,LSS,LT,LT/A,LTJ,LW,LW/A,LWD1,LWD1/A,LX,LX/A,LXE,LXE/A,LXE8,LXE8/A,LXQ4,LXQ4/A,LXU,LXU/A,LXZ,LX16,PAE2,PAE2/A,PXE8,PXE8/A,QA,QAB1,QAB3,QAB3/A,QAE,QAE2,QAE2/A,QAE6,QAE6/A,QAG,QAG/A,QAG2,QAG2/A,QAQ,QAQ4,QAQ4/A,QAR2,QAR2/A,QAW,QAW/A,QA2,QA2/A,QE,QE/A,QH,QH/A,QHB5,QHC,QHE,QHE4,QHE4/A,QHP1,QHP1/A,QHQ4,QHQ4/A,QHR,QHR/A,QHR4,QHR4/A,QHZ,QHZ/A,QH26,QH26/A,QKE3,QKE3/A,QKE4,QL2,QME2,QME2/A,QMH,QMH/A,QP,QP/A,QSC,QSC9,QSC9/A,QSE,QSE/A,QSE2,QSE8,QSE8/A,QT,QT/A,QWA2,QWA4,QWA4/A,QWH2,QWH2/A,QX,QX/A,QXB,QXB/A,QXB6,QXB6/A,QXB7,QXB7/A,QXC,QXC4,QXC4/A,QXC6,QXC6/A,QXC9,QXC9/A,QXE,QXE/A,QXEB,QXE4,QXE4/A,QXE6,QXE6/A,QXE8,QXE8/A,QXQ4,QXQ4/A,QXU,QXU/A,QX26,QX26/A,RA,RA2,RA2/A,RH,RHE,RHE4,RHE4/A,RHQ4,RHQ4/A,RH26,RH26/A,RSC2,RSC2/A,RSS,RSS/A,RX,RX/A,RXP,RXP/A,RXQ4,RXQ4/A,RXU,RXU/A,SE,SE/A,SH,SH/A,SHE,SHEZ,SHQ4,SHQ4/A,SJ,SJ/A,SJG,SJG/A,SJP,SK,SKE1,SME1,SME1/A,SME6,SME6/A,SMX2,SW,SWA4,SWC4,SWC4/A,SWE,SX,SX/A,SXB,SXB/A,SXB7,SXB7/A,SXE,SXE/A,SXEB,SXEB/A,SXE4,SXE4/A,SXE8,SXE8/A,SXQ4,SXQ4/A,SXU,SXU/A,SX2,VA,VAW,VA2,VA2/A,VDE,VDE2,VDE2/A,VMA4,VME2,VME2/A,VME4,VM2,VM2/A,VWN2,VWN2/A
20	16594-883-010	HOLDER, WIRE	1	-	-	-----	LJ,LJ/A,LJC,LJC/A,LJG,LJG/A,LSS,LT,LT/A,LTJ,LWD1,LWD1/A,QKE3,QKE3/A,QKE4,SJ,SJ/A,SJG,SJG/A,SJP,SK,SKE1,SME6,SME6/A,SMX2,VMA4,VME4
21	16594-883-010	HOLDER, WIRE	1	-	-	-----	LTJ,LWD1,LWD1/A,QKE3,QKE3/A,QKE4,QME2,QME2/A,SKE1



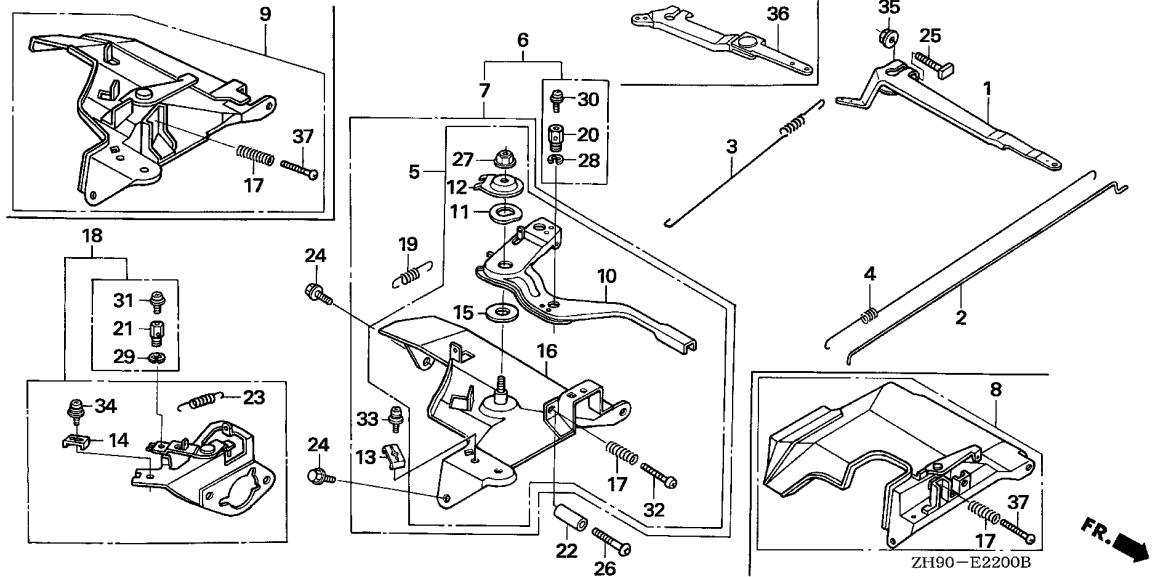

Ref. No.	Part No.	Description	Reqd. QTY			Serial No.	Parts catalogue code
			(1)	(2)	(3)		
22	16599-ZG1-M10	COLLAR, STOPPER	(1)	(1)	(1)	-----	HH,HX,HXQ4,HXQ4/A,HX26,HX8,LH,LHB1,LHB3,LHE,LHQ4,LW,LX,LXE,LXE8,LXQ4,LXQ4/A,LXU,LXZ,LX16,L1,L1/A,PX,PXE8,PXU,PX26,QA,QAB1,QAB3,QAE,QAE6,QAQ4,QAQ4/A,QD,QE,QE/A,QH,QHC,QHE,QHE4,QHE4/A,QHP1,QHQ4,QHQ4/A,QHR,QHR/A,QHR4,QHR4/A,QHZ,QH26,QKE3,QKE3/A,QME2,QME2/A,QMH,QP,QSE,QSE8,QT,QWA4,QWA4/A,QX,QXB,QXB/A,QXB6,QXB7,QXB7/A,QXC,QXC4,QXC4/A,QXC6,QXE,QXE4,QXE4/A,QXE6,QXE8,QXQ4,QXQ4/A,QXU,QX26,Q1,Q1/A,Q2,RD,RH,RHE,RHE4,RHE4/A,RHQ4,RHQ4/A,RH26,RX,RXQ4,RXQ4/A,R1,R1/A,SD,SE,SE/A,SH,SHE,SHEZ,SHQ4,SHQ4/A,SKE1,SMC4,SMC4/A,SMD,SME1,SME1/A,SME6,SME6/A,SN,SW,SWA4,SWC4,SWC4/A,SWE,SX,SXB,SXB/A,SXB7,SXB7/A,SXE,SXE,SXE8,SXE8/A,SXE4,SXE4/A,SXE8,SXQ4,SXQ4/A,SXU,VD16,VEB6,VH,VMA4,VME4,VNG1,VNG1/A,VN17,VN17/A,VPE4,VPE4/A,VPE5,VPE7,VPE7/A,VPX4,VPX4/A,VPX5,VPX7,VPX7/A,VSD7,VSD7/A,VSH7,VS37,VS37/A,VWT4,VWT4/A,VX,VXB,VXB/A,VXB2,VXB6,VXB7,VXB7/A,VXE,VXE8,VXE8/A,VXE4,VXE4/A,VXE6,VXE7,VXE7/A,VXP,VXP,VXPQ,VXPQ4,VXPQ4/A,VXTB,VX26,V1,WMA4,W1,W1/A
23	16615-ZE2-810	SPRING, RETURN	1	-	-	-----	LTJ,LWD1,LWD1/A,QKE3,QKE3/A,QKE4,QME2,QME2/A,SKE1

Ref. No.	Part No.	Description	Reqd. QTY			Serial No.	Parts catalogue code
			(1)	(2)	(3)		
24	90013-883-000	BOLT, FLANGE, 6X12(CT200) ...	2	2	-	-----	ES1,ES1/A,ES3,ES3/A,HA,HAQ,HA2,HA2/A,HEA,HEA2,HEA2/A,HEA8,HEA8/A,HH,HX,HX/A,HXQ4,HXQ4/A,HX26,HX26/A,HX8,HX8/A,LH,LH/A,LHB1,LHB3,LHB5,LHE,LHE/A,LHQ4,LJ,LJ/A,LJC,LJC/A,LJG,LJG/A,LSS,LT,LT/A,LTJ,LW,LW/A,LWD1,LWD1/A,LX,LX/A,LXE,LXE/A,LXE8,LXE8/A,LXQ4,LXQ4/A,LXU,LXU/A,LXZ,LX16,L1,L1/A,PA,PAE2,PAE2/A,PA2,PA2/A,PX,PX/A,PXE8,PXE8/A,PXU,PXU/A,PX26,PX26/A,QA,QAB1,QAB3,QAB3/A,QAE,QAE2,QAE2/A,QAE6,QAE6/A,QAG,QAG/A,QAG2,QAG2/A,QAQ,QAQ4,QAQ4/A,QAR2,QAR2/A,QAW,QAW/A,QA2,QA2/A,QD,QD/A,QE,QE/A,QH,QH/A,QHB5,QHC,QHE,QHE4,QHE4/A,QHP1,QHP1/A,QHQ4,QHQ4/A,QHR,QHR/A,QHR4,QHR4/A,QHZ,QHZ/A,QH26,QH26/A,QKE3,QKE3/A,QKE4,QL2,QME2,QME2/A,QMH,QMH/A,QP,QP/A,QSC,QSC9,QSC9/A,QSE,QSE/A,QSE2,QSE8,QSE8/A,QT,QT/A,QWA2,QWA4,QWA4/A,QWH2,QWH2/A,QX,QX/A,QXB,QXB/A,QXB6,QXB6/A,QXB7,QXB7/A,QXC,QXC4,QXC4/A,QXC6,QXC6/A,QXC9,QXC9/A,QXE,QXE/A,QXEB,QXE4,QXE4/A,QXE6,QXE6/A,QXE8,QXE8/A,QXQ4,QXQ4/A,QXU,QXU/A,QX26,QX26/A,Q1,Q1/A,Q2,RA,RA2,RA2/A,RD,RD/A,RH,RHE,RHE4,RHE4/A,RHQ4,RHQ4/A,RH26,RH26/A,RSC2,RSC2/A,RSS,RSS/A,RX,RX/A,RXQ4,RXQ4/A,RXU,RXU/A,SD,SD/A,SE,SE/A,SH,SH/A,SHE,SHEZ,SHQ4,SHQ4/A,SJ,SJ/A,SJG,SJG/A,SJP,SK,SKE1,SMC4,SMC4/A,SMD,SME1,SME1/A,SME6,SME6/A,SMX2,SN,SN/A,SW,SWA4,SWC4,SWC4/A,SWE,SX,SX/A,SXB,SXB/A,SXB7,SXB7/A,SXE,SXE/A,SXEB,SXEB/A,SXE4,SXE4/A,SXE8,SXE8/A,SXQ4,SXQ4/A,SXU,SXU/A, SX2,S1,S1/A,VA,VAG2,VAG2/A,VAW,VAW1,VA2,VA2/A,VDE,VDE2,VDE2/A,VD16,VEB6,VH,VKB2,VKB2/A,VKE4,VKX4,VMA4,VME2,VME2/A,VME4,VMS2,VMT,VMT/A,VMX2,VM2,VM2/A,VNG1,VNG1/A,VNT2,VNT2/A,VN17,VN17/A,VPE4,VPE4/A,VPE5,VPE7,VPE7/A,VPX4,VPX4/A,VPX5,VPX7,VPX7/A,VSD,VSD/A,VSD3,VSD3/A,VSD7,VSD7/A,VSH7,VS3,VS37,VS37/A,VWA,VWA2,VWA2/A,VWN2,VWN2/A,VWT4,VWT4/A,VW12,VW12/A,VW22,VX,VX/A,VXB,VXB/A,VXB2,VXB6,VXB7,VXB7/A,VXE,VXEB,VXEB/A,VXE4,VXE4/A,VXE6,VXE6/A,VXE7,VXE7/A,VXG,VXQ4,VXQ4/A,VXTB,VXT1,VXT1/A,VXU,VXU/A,VXU1,VXU1/A,VX26,V1,WMA4,WMT8,WMT8/A,WXE8,WXE8/A,W1,W1/A
			-	(2)	-	-----	R1,R1/A
			-	-	2		



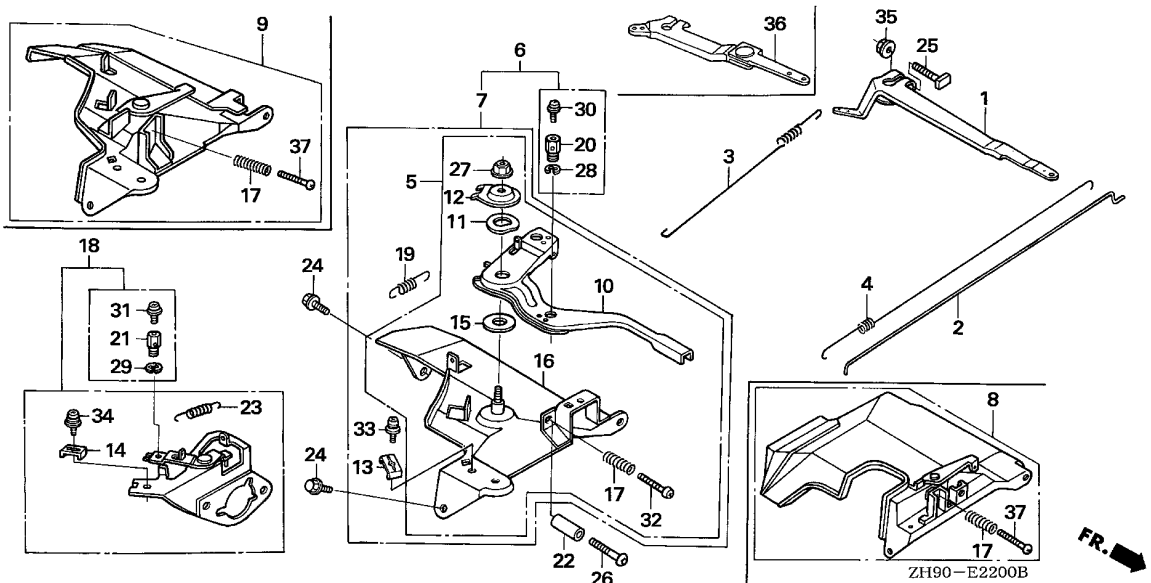

Ref. No.	Part No.	Description	Reqd. QTY			Serial No.	Parts catalogue code
			(1)	(2)	(3)		
25	90015-ZE5-010	BOLT, GOVERNOR ARM	1	-	-		ESS,ESS/A,ES1,ES1/A,ES3,ES3/A,HA,HAQ,HA2,HA2/A,HEA,HEA2,HEA2/A,HEA8,HEA8/A,HH,HX,HX/A,HXQ4,HXQ4/A,HX26,HX26/A,HX8,HX8/A,LH,LH/A,LHB1,LHB3,LHB5,LHE,LHE/A,LHQ4,LJ,LJ/A,LJC,LJC/A,LJG,LJG/A,LSS,LT,LT/A,LTJ,LW,LW/A,LWD1,LWD1/A,LX,LX/A,LXE,LXE/A,LXE8,LXE8/A,LXQ4,LXQ4/A,LXU,LXU/A,LXZ,LX16,PA,PAE2,PAE2/A,PA2,PA2/A,PX,PX/A,PXE8,PXE8/A,PXU,PXU/A,PX26,PX26/A,QA,QAB1,QAB3,QAB3/A,QAE,QAE2,QAE2/A,QAE6,QAE6/A,QAG,QAG/A,QAG2,QAG2/A,QAQ,QAQ4,QAQ4/A,QAR2,QAR2/A,QAW,QAW/A,QA2,QA2/A,QD,QD/A,QE,QE/A,QH,QH/A,QHB5,QHC,QHE,QHE4,QHE4/A,QHP1,QHP1/A,QHQ4,QHQ4/A,QHR,QHR/A,QHR4,QHR4/A,QHZ,QHZ/A,QH26,QH26/A,QKE3,QKE3/A,QKE4,QL2,QME2,QME2/A,QMH,QMH/A,QP,QP/A,QSC,QSC9,QSC9/A,QSE,QSE/A,QSE2,QSE8,QSE8/A,QT,QT/A,QWA2,QWA4,QWA4/A,QWH2,QWH2/A,QX,QX/A,QXB,QXB/A,QXB6,QXB6/A,QXB7,QXB7/A,QXC,QXC4,QXC4/A,QXC6,QXC6/A,QXC9,QXC9/A,QXE,QXE/A,QXEB,QXE4,QXE4/A,QXE6,QXE6/A,QXE8,QXE8/A,QXQ4,QXQ4/A,QXU,QXU/A,QX26,QX26/A,RA,RA2,RA2/A,RD,RD/A,RH,RHE,RHE4,RHE4/A,RHQ4,RHQ4/A,RH26,RH26/A,RSC2,RSC2/A,RSS,RSS/A,RX,RX/A,RXQ4,RXQ4/A,RXU,RXU/A,SD,SD/A,SE,SE/A,SH,SH/A,SHE,SHEZ,SHQ4,SHQ4/A,SJ,SJ/A,SJG,SJG/A,SJP,SK,SKE1,SMC4,SMC4/A,SMD,SME1,SME1/A,SME6,SME6/A,SMX2,SN,SN/A,SW,SWA4,SWC4,SWC4/A,SWE,SX,SX/A,SXB,SXB/A,SXB7,SXB7/A,SXE,SXE/A,SXEB,SXEB/A,SXE4,SXE4/A,SXE8,SXE8/A,SXQ4,SXQ4/A,SXU,SXU/A,SX2,VA,VAG2,VAG2/A,VAW,VAW1,VA2,VA2/A,VDE,VDE2,VDE2/A,VD16,VEB6,VH,VKB2,VKB2/A,VKE4,VKX4,VMA4,VME2,VME2/A,VME4,VMS2,VMT,VMT/A,VMX2,VM2,VM2/A,VNG1,VNG1/A,VNT2,VNT2/A,VN17,VN17/A,VPE4,VPE4/A,VPE5,VPE7,VPE7/A,VPX4,VPX4/A,VPX5,VPX7,VPX7/A,VSD,VSD/A,VSD3,VSD3/A,VSD7,VSD7/A,VSH7,VS3,VS37,VS37/A,VWA,VWA2,VWA2/A,VWN2,VWN2/A,VWT4,VWT4/A,VW12,VW12/A,VW22,VX,VX/A,VXB,VXB/A,VXB2,VXB2/VXB7,VXB7/A,VXE,VXE/VXE8/VXE8/A,VXE4,VXE4/A,VXE6,VXE6/A,VXE7,VXE7/A,VXG,VXQ4,VXQ4/A,VXTB,VXT1,VXT1/A,VXU,VXU/A,VXU1,VXU1/A,VX26,WMA4,WMT8,WMT8/A,WXE8,WXE8/A



Ref. No.	Part No.	Description	Reqd. QTY			Serial No.	Parts catalogue code
			(1)	(2)	(3)		
26	90016-ZG9-N30	SCREW, RECESSED, 5X25	(1)	-	(1)		HXQ4, HXQ4/A, LHQ4, LXQ4, LXQ4/A, QAQ4, QAQ4/A, QE/A, QHE4, QHE4/A, QHQ4, QHQ4/A, QHR, QHR/A, QHR4, QHR4/A, QKE3, QKE3/A, QKE4, QME2, QME2/A, QWA4, QWA4/A, QXB/A, QXB7, QXB7/A, QXC4, QXC4/A, QXE4, QXE4/A, QXQ4, QXQ4/A, RHE4, RHE4/A, RHQ4, RHQ4/A, RXQ4, RXQ4/A, SE/A, SHQ4, SHQ4/A, SKE1, SMC4, SMC4/A, SME1, SME1/A, SME6, SME6/A, SWA4, SWC4, SWC4/A, SXB/A, SXB7, SXB7/A, SXEB/A, SXE4, SXE4/A, SXQ4, SXQ4/A, VD16, VEB6, VMA4, VME4, VNG1/A, VN17, VN17/A, VPE4, VPE4/A, VPE5, VPE7, VPE7/A, VPX4, VPX4/A, VPX5, VPX7, VPX7/A, VSD/A, VSD3/A, VSD7, VSD7/A, VSH7, VS37, VS37/A, VWT4, VWT4/A, VXB/A, VXB7, VXB7/A, VXE4, VXE4/A, VXE7, VXE7/A, VXQP, VXQ4, VXQ4/A, VXTB, WMA4
27	90114-SAO-000	NUT, SELF-LOCK, 6MM	(1)	-	-	1106274	QE, QXB, SE, SXB, SXEB, VNG1, VSD, VSD3, VXB, VXE, VXE4, VXE4/A, HA, HAQ, HA2, HA2/A, HEA, HEA2, HEA2/A, HEA8, HEA8/A, HH, HX, HX/A, HXQ4, HXQ4/A, HX26, HX26/A, HX8, HX8/A, LH, LH/A, LHB1, LHB3, LHB5, LHE, LHE/A, LHQ4, LJ, LJ/A, LJC, LJC/A, LJG, LJG/A, LSS, LT, LT/A, LTJ, LW, LW/A, LWD1, LWD1/A, LX, LX/A, LXE, LXE/A, LXEB, LXEB/A, LXQ4, LXQ4/A, LXU, LXU/A, LXZ, LX16, PA, PAE2, PAE2/A, PA2, PA2/A, PX, PX/A, PXE8, PXE8/A, PXU, PXU/A, PX26, PX26/A, QA, QAB1, QAB3, QAB3/A, QAE, QAE2, QAE2/A, QAE6, QAE6/A, QAG, QAG/A, QAG2, QAG2/A, QAQ, QAQ4, QAQ4/A, QAR2, QAR2/A, QAW, QAW/A, QA2, QA2/A, QD, QD/A, QE, QE/A, QH, QH/A, QHB5, QHC, QHE, QHE4, QHE4/A, QHP1, QHP1/A, QHQ4, QHQ4/A, QHR, QHR/A, QHR4, QHR4/A, QHZ, QHZ/A, QH26, QH26/A, QKE3, QKE3/A, QKE4, QL2, QME2, QME2/A, QMH, QMH/A, QP, QP/A, QSC, QSC9, QSC9/A, QSE, QSE/A, QSE2, QSE8, QSE8/A, QT, QT/A, QWA2, QWA4, QWA4/A, QWH2, QWH2/A, QX, QX/A, QXB, QXB/A, QXB6, QXB6/A, QXB7, QXB7/A, QXC, QXC4, QXC4/A, QXC6, QXC6/A, QXC9, QXC9/A, QXE, QXE/A, QXEB, QXE4, QXE4/A, QXE6, QXE6/A, QXE8, QXE8/A, QXQ4, QXQ4/A, QXU, QXU/A, QX26, QX26/A, RA, RA2, RA2/A, RD, RD/A, RH, RHE, RHE4, RHE4/A, RHQ4, RHQ4/A, RH26, RH26/A, RSC2, RSC2/A, RSS, RSS/A, RX, RX/A, RXQ4, RXQ4/A, RXU, RXU/A, SD, SD/A, SE, SE/A, SH, SH/A, SHE, SHEZ, SHQ4, SHQ4/A, SJ, SJ/A, SJG, SJG/A, SJP, SK, SKE1, SMC4, SMC4/A, SMD, SME1, SME1/A, SME6, SME6/A, SMX2, SN, SN/A, SW, SWA4, SWC4, SWC4/A, SWE, SX, SX/A, SXB, SXB/A, SXB7, SXB7/A, SXE, SXE/A, SXEB, SXEB/A, SXE4, SXE4/A, SXE8, SXE8/A, SXQ4, SXQ4/A, SXU, SXU/A, SX2, VA, VAW, VA2, VA2/A, VDE, VDE2, VDE2/A, VD16, VEB6, VH, VMA4, VME2, VME2/A, VME4, VM2, VM2/A, VNG1, VNG1/A, VN17, VN17/A, VWN2, VWN2/A, VX, VX/A, VXB, VXB/A, VXB2, VXB6, VXB7, VXB7/A, VXE, VXE4, VXE4/A, VXE6, VXE6/A, VXE7, VXE7/A, VXQ4, VXQ4/A, VXTB, VX26, WMA4, WMT8, WMT8/A, WXE8, WXE8/A
28	90605-230-000	CIRCLIP, 5MM	-	(1)	1		LJ, LJ/A, LJC, LJC/A, LJG, LJG/A, LSS, LT, LT/A, LTJ, LWD1, LWD1/A, QKE3, QKE3/A, QKE4, S, SJ, SJ/A, SJG, SJG/A, SJP, SK, SKE1, SME6, SME6/A, SMX2, VMA4, VME4
29	90605-230-000	CIRCLIP, 5MM	-	(1)	-		LTJ, LWD1, LWD1/A, QKE3, QKE3/A, QKE4, QME2, QME2/A, SKE1
30	93500-04006-0H	SCREW, PAN, 4X6	-	(1)	-		LJ, LJ/A, LJC, LJC/A, LJG, LJG/A, LSS, LT, LT/A, LTJ, LWD1, LWD1/A, QKE3, QKE3/A, QKE4, S, SJ, SJ/A, SJG, SJG/A, SJP, SK, SKE1, SME6, SME6/A, SMX2, VMA4, VME4
31	93500-04006-0H	SCREW, PAN, 4X6	-	(1)	-		LTJ, LWD1, LWD1/A, QKE3, QKE3/A, QKE4, QME2, QME2/A, SKE1



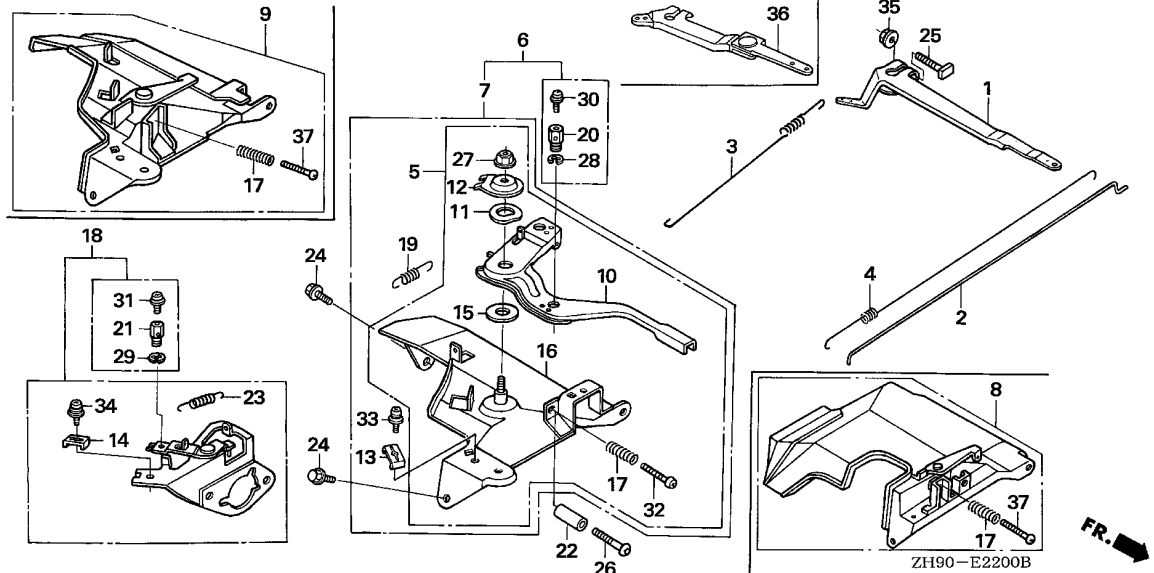

Ref. No.	Part No.	Description	Reqd. QTY			Serial No.	Parts catalogue code
			(1)	(2)	(3)		
32	93500-05028-0A	SCREW, PAN, 5X28	1	(1)	-		HA,HAQ,HA2,HA2/A,HEA,HEA2,HEA2/A,HEA8,HEA8/A,HH,HX,HX/A,HXQ4 HXQ4/A,HX26,HX26/A,HX8,HX8/A,LH,LH/A,LHB1,LHB3,LHB5,LHE,LHE/A LHQ4,LJ,LJ/A,LJC,LJC/A,LJG,LJG/A,LSS,LT,LT/A,LTJ,LW,LW/A,LWD1 LWD1/A,LX,LX/A,LXE,LXE/A,LXE8,LXE8/A,LXQ4,LXQ4/A,LXU,LXU/A,LXZ LX16,L1,L1/A,PA,PAE2,PAE2/A,PA2,PA2/A,PX,PX/A,PXE8,PXE8/A,PXU PXU/A,PX26,PX26/A,QA,QAB1,QAB3,QAB3/A,QAE,QAE2,QAE2/A,QAE6,QAE6/A QAG,QAG/A,QAG2,QAG2/A,QAQ,QAQ4,QAQ4/A,QAR2,QAR2/A,QAW,QAW/A,QA2 QA2/A,QD,QD/A,QE,QE/A,QH,QH/A,QHB5,QHC,QHE,QHE4,QHE4/A,QHP1 QHP1/A,QHQ4,QHQ4/A,QHR,QHR/A,QHR4,QHR4/A,QHZ,QHZ/A,QH26,QH26/A QKE3,QKE3/A,QKE4,QL2,QME2,QME2/A,QMH,QMH/A,QP,QP/A,QSC,QSC9 QSC9/A,QSE,QSE/A,QSE2,QSE8,QSE8/A,QT,QT/A,QWA2,QWA4,QWA4/A,QWH2 QWH2/A,QX,QX/A,QXB,QXB/A,QXB6,QXB6/A,QXB7,QXB7/A,QXC,QXC4,QXC4/A QXC6,QXC6/A,QXC9,QXC9/A,QXE,QXE/A,QXEB,QXE4,QXE4/A,QXE6,QXE6/A QXE8,QXE8/A,QXQ4,QXQ4/A,QXU,QXU/A,QX26,QX26/A,Q1,Q1/A,RA,RA2 RA2/A,RD,RD/A,RH,RHE,RHE4,RHE4/A,RHQ4,RHQ4/A,RH26,RH26/A,RSC2 RSC2/A,RSS,RSS/A,RX,RX/A,RXQ4,RXQ4/A,RXU,RXU/A,SD,SD/A,SE,SE/A,SH SH/A,SHE,SHEZ,SHQ4,SHQ4/A,SJ,SJ/A,SJG,SJG/A,SJP,SK,SKE1,SMC4 SMC4/A,SMD,SME1,SME1/A,SME6,SME6/A,SMX2,SN,SN/A,SW,SWA4,SWC4 SWC4/A,SWE,SX,SX/A,SXB,SXB/A,SXB7,SXB7/A,SXE,SXE/A,SXEB,SXEB/A SXE4,SXE4/A,SXE8,SXE8/A,SXQ4,SXQ4/A,SXU,SXU/A,SX2,S1,S1/A,VA,VAW VA2,VA2/A,VDE,VDE2,VDE2/A,VD16,VEB6,VH,VMA4,VME2,VME2/A,VME4,VM2 VM2/A,VNG1,VNG1/A,VN17,VN17/A,VWN2,VWN2/A,VX,VX/A,VXB,VXB/A,VXB2 VXB6,VXB7,VXB7/A,VXE,VXEB,VXEB/A,VXE4,VXE4/A,VXE6,VXE6/A,VXE7 VXE7/A,VXQ4,VXQ4/A,VXTB,VX26,V1,WMA4,WMT8,WMT8/A,WXE8,WXE8/A,W1 W1/A Q2,R1,R1/A
			-	-	1		

2

Ref. No.	Part No.	Description	Reqd. QTY			Serial No.	Parts catalogue code
			(1)	(2)	(3)		
33	93893-05016-00	SCREW-WASHER, 5X16	1	(1)	-	1053526	LH,LHE,LJ,LW,LX,LXZ,L1,QA,QAE,QAQ,QE,QH,QHC,QHE,QP,QX,QXB,QXC,QXE,QXEB,Q1,Q2,RA,RH,RHE,RX,R1,SE,SH,SHE,SHEZ,SJ,SJP,SK,SW,SWE,SX,SBX,SXE,SXEB,S1,VA,VAW,V1,W1
	93500-05016-0A	SCREW, PAN, 5X16	1	(1)	1		LH/A,LHB1,LHB3,LHB5,LHE/A,LHQ4,LJ/A,LJC,LJC/A,LJG,LJG/A,LSS,LT,LT/A,LTJ,LW/A,LWD1,LWD1/A,LX/A,LXE,LXE/A,LXE8,LXE8/A,LXQ4,LXQ4/A,LXU,LXU/A,LX16,L1/A,PAE2,PAE2/A,PXE8,PXE8/A,QAB1,QAB3,QAB3/A,QAE2,QAE2/A,QAE6,QAE6/A,QAG,QAG/A,QAG2,QAG2/A,QAQ,QAQ4,QAQ4/A,QAR2,QAR2/A,QAW,QAW/A,QA2,QA2/A,QE/A,QH/A,QHB5,QHE4,QHE4/A,QHP1,QHP1/A,QHQ4,QHQ4/A,QHR,QHR/A,QHR4,QHR4/A,QHZ,QHZ/A,QH26,QH26/A,QKE3,QKE3/A,QKE4,QL2,QME2,QME2/A,QMH,QMH/A,QP/A,QSC,QSC9,QSC9/A,QSE,QSE/A,QSE2,QSE8,QSE8/A,QT,QT/A,QWA2,QWA4,QWA4/A,QWH2,QWH2/A,QX/A,QXB/A,QXB6,QXB6/A,QXB7,QXB7/A,QXC4,QXC4/A,QXC6,QXC6/A,QXC9,QXC9/A,QXE/A,QXE4,QXE4/A,QXE6,QXE6/A,QXE8,QXE8/A,QXQ4,QXQ4/A,QXU,QXU/A,QX26,QX26/A,Q1/A,RA2,RA2/A,RHE4,RHE4/A,RHQ4,RHQ4/A,RH26,RH26/A,RSC2,RSC2/A,RSS,RSS/A,RX/A,RXP,RXP/A,RXQ4,RXQ4/A,RXU,RXU/A,R1/A,SE/A,SH/A,SHQ4,SHQ4/A,SJ/A,SJG,SJG/A,SKE1,SME1,SME1/A,SME6,SME6/A,SMX2,SWA4,SWC4,SWC4/A,SX/A,SBX/A,SBX7,SBX7/A,SXE/A,SXEB/A,SXE4,SXE4/A,SXE8,SXE8/A,SXQ4,SXQ4/A,SXU,SXU/A,SX2,S1/A,VA2,VA2/A,VDE,VDE2,VDE2/A,VMA4,VME2,VME2/A,VME4,VM2,VM2/A,VWN2,VWN2/A,W1/A
			1	(1)	-	1053527	LH,LHE,LJ,LW,LX,LXZ,L1,QA,QAE,QAQ,QE,QH,QHC,QHE,QP,QX,QXB,QXC,QXE,QXEB,Q1,Q2,RA,RH,RHE,RX,R1,SE,SH,SHE,SHEZ,SJ,SJP,SK,SW,SWE,SX,SBX,SXE,SXEB,S1,VA,VAW,V1,W1
34	93893-05016-00	SCREW-WASHER, 5X16	1	-	-		LTJ,LWD1,LWD1/A,QKE3,QKE3/A,QKE4,QME2,QME2/A,SKE1
35	94050-06000	NUT, FLANGE, 6MM	1	-	-		ESS,ESS/A,ES1,ES1/A,ES3,ES3/A,HA,HAQ,HA2,HA2/A,HEA,HEA2,HEA2/A,HEA8,HEA8/A,HH,HX,HX/A,HXQ4,HXQ4/A,HX26,HX26/A,HX8,HX8/A,LH,LH/A,LHB1,LHB3,LHB5,LHE,LHE/A,LHQ4,LJ,LJ/A,LJC,LJC/A,LJG,LJG/A,LSS,LT,LT/A,LTJ,LW,LW/A,LWD1,LWD1/A,LX,LX/A,LXE,LXE/A,LXE8,LXE8/A,LXQ4,LXQ4/A,LXU,LXU/A,LXZ,LX16,PA,PAE2,PAE2/A,PA2,PA2/A,PX,PX/A,PXE8,PXE8/A,PXU,PXU/A,PX26,PX26/A,QA,QAB1,QAB3,QAB3/A,QAE,QAE2,QAE2/A,QAE6,QAE6/A,QAG,QAG/A,QAG2,QAG2/A,QAQ,QAQ4,QAQ4/A,QAR2,QAR2/A,QAW,QAW/A,QA2,QA2/A,QD,QD/A,QE,QE/A,QH,QH/A,QHB5,QHC,QHE,QHE4,QHE4/A,QHP1,QHP1/A,QHQ4,QHQ4/A,QHR,QHR/A,QHR4,QHR4/A,QHZ,QHZ/A,QH26,QH26/A,QKE3,QKE3/A,QKE4,QL2,QME2,QME2/A,QMH,QMH/A,QP,QP/A,QSC,QSC9,QSC9/A,QSE,QSE/A,QSE2,QSE8,QSE8/A,QT,QT/A,QWA2,QWA4,QWA4/A,QWH2,QWH2/A,QX,QX/A,QXB,QXB/A,QXB6,QXB6/A,QXB7,QXB7/A,QXC,QXC4,QXC4/A,QXC6,QXC6/A,QXC9,QXC9/A,QXE,QXE/A,QXEB,QXE4,QXE4/A,QXE6,QXE6/A,QXE8,QXE8/A,QXQ4,QXQ4/A,QXU,QXU/A,QX26,QX26/A,RA,RA2,RA2/A,RD,RD/A,RH,RHE,RHE4,RHE4/A,RHQ4,RHQ4/A,RH26,RH26/A,RSC2,RSC2/A,RSS,RSS/A,RX,RX/A,RXQ4,RXQ4/A,RXU,RXU/A,SD,SD/A,SE,SE/A,SH,SH/A,SHE,SHEZ,SHQ4,SHQ4/A,SJ,SJ/A,SJG,SJG/A,SJP,SK,SKE1,SMC4,SMC4/A,SMD,SME1,SME1/A,SME6,SME6/A,SMX2,SN,SN/A,SW,SWA4,SWC4,SWC4/A,SWE,SX,SX/A,SBX,SBX/A,SBX7,SBX7/A,SXE,SXE/A,SXEB,SXEB/A,SXE4,SXE4/A,SXE8,SXE8/A,SXQ4,SXQ4/A,SXU,SXU/A,SX2,VA,VAG2,VAG2/A,VAW,VAW1,VA2,VA2/A,VDE,VDE2,VDE2/A,VD16,VEB6,VH,VKB2,VKB2/A,VKE4,VKX4,VMA4,VME2,VME2/A,VME4,VMS2,VMT,VMT/A,VMX2,VM2,VM2/A,VNG1,VNG1/A,VNT2,VNT2/A,VN17,VN17/A,VPE4,VPE4/A,VPE5,VPE7,VPE7/A,VPX4,VPX4/A,VPX5,VPX7,VPX7/A,VSD,VSD/A,VSD3,VSD3/A,VSD7,VSD7/A,VSH7,VS3,VS37,VS37/A,VWA,VWA2,VWA2/A,VWN2,VWN2/A,VWT4,VWT4/A,VW12,VW12/A,VW22,VX,VX/A,VXB,VXB/A,VXB2,VXB6,VXB7,VXB7/A,VXE,VXEB,VXEB/A,VXE4,VXE4/A,VXE6,VXE6/A,VXE7,VXE7/A,VXG,VXQ4,VXQ4/A,VXTB,VXT1,VXT1/A,VXU,VXU/A,VXU1,VXU1/A,VX26,WMA4,WMT8,WMT8/A,WXE8,WXE8/A
			-	1	1		
36	16550-ZE2-700	ARM COMP., GOVERNOR	1	-	-		ESS,ESS/A,VAG2,VAG2/A,VKB2,VKB2/A,VKE4,VKX4,VMS2,VMT,VMT/A,VWA,VWA2,VWA2/A
37	93500-05035-0A	SCREW, PAN, 5X35	1	-	-		ES1,ES1/A,ES3,ES3/A,VAG2,VAG2/A,VAW1,VKB2,VKB2/A,VKE4,VKX4,VMS2,VMT,VMT/A,VMX2,VNT2,VNT2/A,VPE4,VPE4/A,VPE5,VPE7,VPE7/A,VPX4,VPX4/A,VPX5,VPX7,VPX7/A,VSD,VSD/A,VSD3,VSD3/A,VSD7,VSD7/A,VSH7,VS3,VS37,VS37/A,VWA,VWA2,VWA2/A,VWT4,VWT4/A,VW12,VW12/A,VW22,VXG,VXT1,VXT1/A,VXU,VXU/A,VXU1,VXU1/A



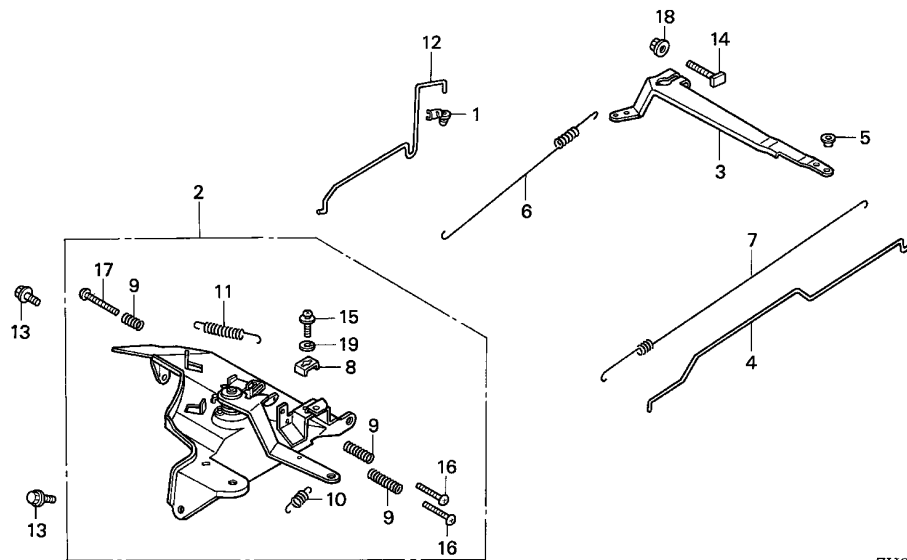

ZH90-E2201



Ref. No.	L.O.N.	(Relative ref. Number) Description	F.R.T.
2	1161A5	CONTROL, THROTTLE/GOVERNOR ...	0.2
3	1161A0	ARM, GOVERNOR	0.2
4	1161B1	ROD, GOVERNOR	0.3
6	1161C5	SPRING, GOVERNOR	0.2
7	1161D3	SPRING, THROTTLE RETURN(A) ...	0.2
12	8101R5	ROD, GOVERNOR CHOKE CONTROL ..	0.2

Ref. No.	Part No.	Description	Reqd. QTY			Serial No.	Parts catalogue code
			(1)	(2)	(3)		
1	16263-ZA0-000	JOINT, ROD	1	-	-	-----	LWD
2	16500-ZE2-P52	CONTROL ASSY.	1	-	-	-----	LWD
3	16551-ZE2-780	ARM, GOVERNOR	1	-	-	-----	LWD
4	16555-ZE2-780	ROD, GOVERNOR	1	-	-	-----	LWD
5	16559-ZE2-780	COLLAR, GOVERNOR ROD	1	-	-	-----	LWD
6	16561-ZE2-000	SPRING, GOVERNOR	1	-	-	-----	LWD
7	16562-ZE2-000	SPRING, THROTTLE RETURN	1	-	-	-----	LWD
8	16576-891-000	HOLDER, CABLE	1	-	-	-----	LWD
9	16584-883-300	SPRING, CONTROL ADJUSTING ...	3	-	-	-----	LWD
10	16592-732-700	SPRING, CABLE RETURN	1	-	-	-----	LWD
11	16592-883-310	SPRING, CABLE RETURN	1	-	-	-----	LWD
12	16674-ZE2-P50	ROD, CHOKE	1	-	-	-----	LWD
13	90013-883-000	BOLT, FLANGE, 6X12(CT200) ...	2	-	-	-----	LWD
14	90015-ZE5-010	BOLT, GOVERNOR ARM	1	-	-	-----	LWD
15	92301-05016-0A	BOLT, RECESSED, 5X16	1	-	-	-----	LWD
16	93500-05025-OH	SCREW, PAN, 5X25	2	-	-	-----	LWD
17	93500-05035-OH	SCREW, PAN, 5X35	1	-	-	-----	LWD
18	94050-06000	NUT, FLANGE, 6MM	1	-	-	-----	LWD
19	94111-05800	WASHER, SPRING, 5MM	1	-	-	-----	LWD

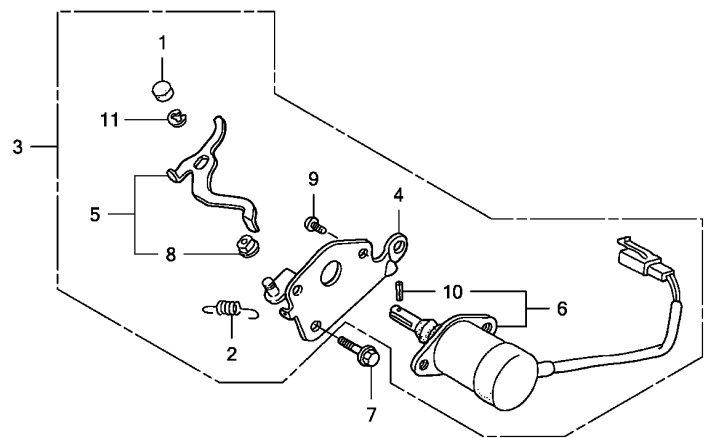

ZH90E2210B



Ref. No.	L.O.N.	(Relative ref. Number) Description	F.R.T.
2	8101Q9	SPRING, CHOKE RETURN	0.2
3	8101S8	THROTTLE, AUTO	0.2
6	6211C5	SOLENOID, AUTO THROTTLE	0.3

Ref. No.	Part No.	Description	Reqd. QTY			Serial No.	Parts catalogue code
			(1)	(2)	(3)		
1	16252-ZA1-000	CAP, CHOKE LEVER	1	-	-	----- VAG2	
	16252-ZA1-010	1	-	-	----- VAG2/A,VMS2,VMT,VMT/A	
2	16268-893-000	SPRING, CHOKE RETURN	1	-	-	----- VAG2,VAG2/A,VMS2,VMT,VMT/A	
3	16270-ZB4-000	AUTO-THROTTLE ASSY.	1	-	-	----- VAG2	
	16270-ZB4-010	1	-	-	----- VAG2/A,VMS2,VMT,VMT/A	
4	16271-ZB4-000	STAY, SOLENOID THROTTLE	1	-	-	----- VAG2,VAG2/A,VMS2,VMT,VMT/A	
5	16273-ZB4-000	LEVER COMP., SOLENOID THROTTLE	1	-	-	----- VAG2,VAG2/A,VMS2,VMT,VMT/A	
6	36160-ZB4-003	SOLENOID ASSY.	1	-	-	----- VAG2,VAG2/A,VMS2,VMT,VMT/A	
7	90013-883-000	BOLT, FLANGE, 6X12(CT200) ...	1	-	-	----- VAG2,VAG2/A,VMS2,VMT,VMT/A	
8	91502-ZB4-701	BUSH, AUTO-THROTTLE LEVER	1	-	-	----- VAG2,VAG2/A,VMS2,VMT,VMT/A	
9	93500-05008-0A	SCREW, PAN, 5X8	2	-	-	----- VAG2,VAG2/A,VMS2,VMT,VMT/A	
10	94305-20062	PIN, SPRING, 2X6	1	-	-	----- VAG2,VAG2/A,VMS2,VMT,VMT/A	
11	94540-04018	E-RING, 4MM	1	-	-	----- VAG2,VAG2/A,VMS2,VMT,VMT/A	



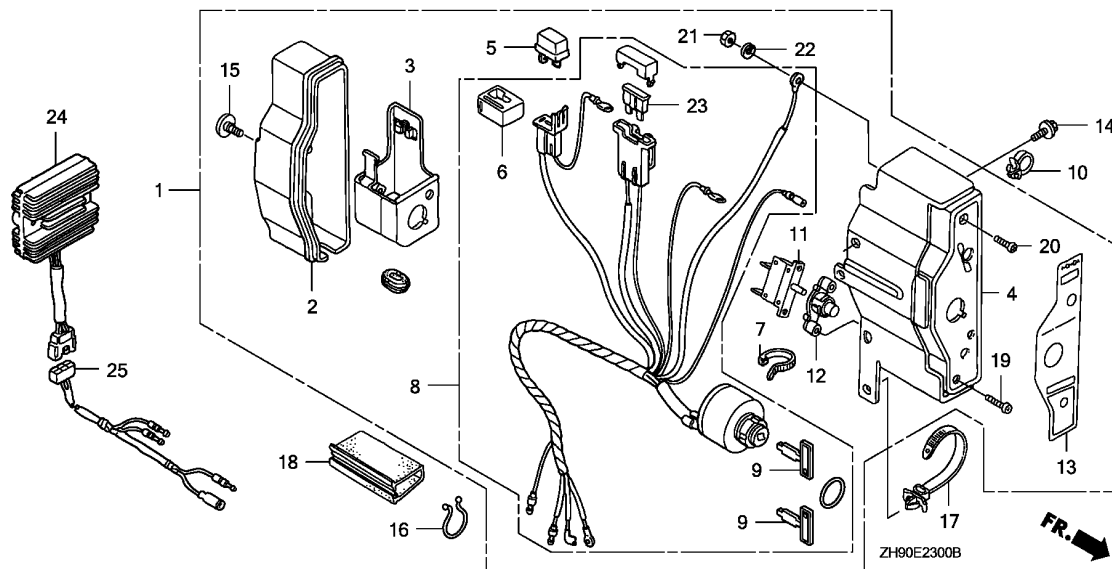

Ref. No.	L.O.N.	(Relative ref. Number) Description	F.R.T.
1	6221N7	BOX, ENGINE CONTROL	0.1
4	6151K5	PANEL, ENGINE CONTROL.	0.2
5	6131B8	RECTIFIER, SILICON	0.1
8	6151E1	SWITCH, COMBINATION	0.2
11	6221D4	PROTECTOR, CIRCUIT	0.2
23	8121A7	FUSE, BLADE	0.1
24	6131B7	RECTIFIER, REGULATOR	0.2
25	6111E6	HARNESS, REGULATOR RECTIFIER .	0.2

Ref. No.	Part No.	Description	Reqd. QTY			Serial No.	Parts catalogue code
			(1)	(2)	(3)		
1	31610-ZE2-013ZB	BOX ASSY., CONTROL (INTERNAL) *R8*.....BRIGHT RED	1	(1)	-	-----	LTJ,L1,Q1,R1,S1,V1,W1
			-	(1)	-	-----	2085591 L1/A,Q1/A,R1/A,S1/A,W1/A
	31610-ZE2-812ZB	BOX ASSY., CONTROL *R8*.....BRIGHT RED	1	(1)	-	-----	LHE,L1,QHE,Q1,Q2,RHE,R1,SHE,SHEZ,SWE,V1,W1
			-	(1)	-	-----	2085591 L1/A,Q1/A,R1/A,W1/A
	31610-ZE2-013ZD	BOX ASSY., CONTROL (INTERNAL) *R280*.....POWER RED	-	(1)	-	2085592	----- L1/A,Q1/A,R1/A,S1/A,W1/A
	31610-ZE2-812ZD	BOX ASSY., CONTROL *R280*.....POWER RED	1	-	-	-----	LHE/A
			-	(1)	-	2085592	----- L1/A,Q1/A,R1/A,W1/A
2	31612-ZE2-003	CASE, CONTROL	1	-	-	-----	LHE,LHE/A,LTJ,QHE,RHE,SHE,SHEZ,SWE
			-	(1)	-	-----	LHE,LHE/A,LTJ,QHE,RHE,SHE,SHEZ,SWE
3	31614-ZE2-003	BRACKET, CASE MOUNTING	1	-	-	-----	LHE,LHE/A,LTJ,QHE,RHE,SHE,SHEZ,SWE
			-	(1)	-	-----	LHE,LHE/A,LTJ,QHE,RHE,SHE,SHEZ,SWE
4	31615-ZE2-003ZB	PANEL COMP., CONTROL *R8*.....BRIGHT RED	1	(1)	-	-----	LHE,LTJ,L1,QHE,Q1,Q2,RHE,R1,SHE,SHEZ,SWE,S1,V1,W1
			-	(1)	-	2050808	----- L1/A,Q1/A,R1/A,S1/A,W1/A
	31615-ZE2-003ZG	*R280*.....POWER RED	1	-	-	-----	LHE/A
			-	(1)	-	2050809	----- L1/A,Q1/A,R1/A,S1/A,W1/A
5	31700-124-008	RECTIFIER ASSY., SILICON (SHINDENGEN)	1	-	-	-----	LHE,LHE/A,LTJ,QHE,RHE,SHE,SHEZ,SWE
			-	(1)	-	-----	LHE,LHE/A,LTJ,QHE,RHE,SHE,SHEZ,SWE
6	32127-738-700	SUSPENSION, COUPLER	1	-	-	-----	LHE,LHE/A,LTJ,QHE,RHE,SHE,SHEZ,SKE1,SWE
			-	(1)	-	-----	LHE,LHE/A,LTJ,QHE,RHE,SHE,SHEZ,SKE1,SWE
7	32902-892-003	BAND	1	-	-	-----	LHE,LHE/A,LTJ,QHE,RHE,SHE,SHEZ,SWE
			-	(1)	-	-----	LHE,LHE/A,LTJ,QHE,RHE,SHE,SHEZ,SWE

Ref. No.	Part No.	Description	Reqd. QTY			Serial No.	Parts catalogue code
			(1)	(2)	(3)		
8	35100-ZE2-023	SWITCH ASSY., COMBINATION ...	1	-	-	-----	LHE,LHE/A,LTJ,QHE,RHE,SHE,SHEZ,SKE1,SWE
			-	(1)	-	-----	
9	35111-880-003	KEY COMP.	2	(2)	-	-----	LHE,L1,QHE,Q1,Q2,RHE,R1,SHE,SHEZ,SKE1,SWE,S1,V1,W1
			2	(2)	-	2233813	LHE/A,L1/A,Q1/A,R1/A,S1/A,W1/A
			2	-	-	2242189	LTJ
	35111-880-013	2	(2)	-	2233814	LHE/A,L1/A,Q1/A,R1/A,S1/A,W1/A
			2	-	-	2242190	LTJ
10	36103-ZE1-000	HOLDER, STOP SWITCH CORD	1	-	-	-----	LHE,LHE/A,LTJ,QHE,RHE,SHE,SHEZ,SWE
			-	(1)	-	-----	
11	38240-VA3-900	PROTECTOR, CIRCUIT (1.0A) ...	1	-	-	-----	LHE,LHE/A,LTJ,QHE,RHE,SHE,SHEZ,SWE
			-	(1)	-	-----	
12	38250-ZA8-701	LENS ASSY., PROTECTOR	1	-	-	-----	LHE,LHE/A,LTJ,QHE,RHE,SHE,SHEZ,SWE
			-	(1)	-	-----	
13	87529-ZE2-010	PANEL, CONTROL BOX (INTERNAL)	1	(1)	-	-----	LTJ,L1,Q1,Q1/A,R1,S1,V1,W1,W1/A
			-	(1)	-	2165395	L1/A,R1/A,S1/A
	87529-ZE2-811	MARK, CONTROL BOX (EXTERNAL)	1	(1)	-	-----	LHE,L1,L1/A,QHE,Q1,Q1/A,Q2,RHE,R1,R1/A,SHE,SHEZ,SWE,V1,W1,W1/A
			1	-	-	2151454	LHE/A
	87529-ZE2-020	PANEL, CONTROL BOX (INTERNAL)	-	(1)	-	2165396	L1/A,R1/A,S1/A
	87529-ZE2-812	MARK, CONTROL BOX (EXP)	1	-	-	2151455	LHE/A
14	90013-883-000	BOLT, FLANGE, 6X12(CT200) ...	2	-	-	-----	LHE,LHE/A,LTJ,QHE,RHE,SHE,SHEZ,SWE
			-	(2)	-	-----	
15	90380-MA6-010	SCREW, SPECIAL, 6X12	1	-	-	-----	LHE,LHE/A,LTJ,QHE,RHE,SHE,SHEZ,SWE
			-	(1)	-	-----	
16	90630-751-000	CLIP, PURSE LOCK	1	-	-	-----	LHE,LHE/A,LTJ,QHE,RHE,SHE,SHEZ,SWE
			-	(1)	-	-----	
17	90672-SA0-003	STRAP, CABLE, 118MM(BLACK) ..	1	-	-	-----	LHE,LHE/A,LTJ,QHE,RHE,SHE,SHEZ,SWE
			-	(1)	-	-----	
18	91406-ZE2-003	TUBE, FASTENER, 30MM	1	-	-	-----	LHE,LHE/A,LTJ,QHE,RHE,SHE,SHEZ,SWE
			-	(1)	-	-----	
19	93500-03012-OH	SCREW, PAN, 3X12	2	-	-	-----	LHE,LHE/A,LTJ,QHE,RHE,SHE,SHEZ,SWE
			-	(2)	-	-----	
20	93500-04012-OH	SCREW, PAN, 4X12	1	-	-	-----	LHE,LHE/A,LTJ,QHE,RHE,SHE,SHEZ,SWE
			-	(1)	-	-----	
21	94001-04390-OS	NUT, HEX., 4MM	1	-	-	-----	LHE,LHE/A,LTJ,QHE,RHE,SHE,SHEZ,SWE
			-	(1)	-	-----	
22	94111-04800	WASHER, SPRING, 4MM	1	-	-	-----	LHE,LHE/A,LTJ,QHE,RHE,SHE,SHEZ,SWE
			-	(1)	-	-----	
23	98200-30500	FUSE, BLADE (5A)	1	-	-	-----	LHE,LHE/A,LTJ,QHE,RHE,SHE,SHEZ,SKE1,SWE
			-	(1)	-	-----	
24	31620-ZG5-013	RECTIFIER ASSY., REGULATOR (20A)	1	-	-	-----	QAR2,QAR2/A
25	32110-ZE2-W00	HARNESS ASSY., SUB WIRE	1	-	-	-----	QAR2,QAR2/A



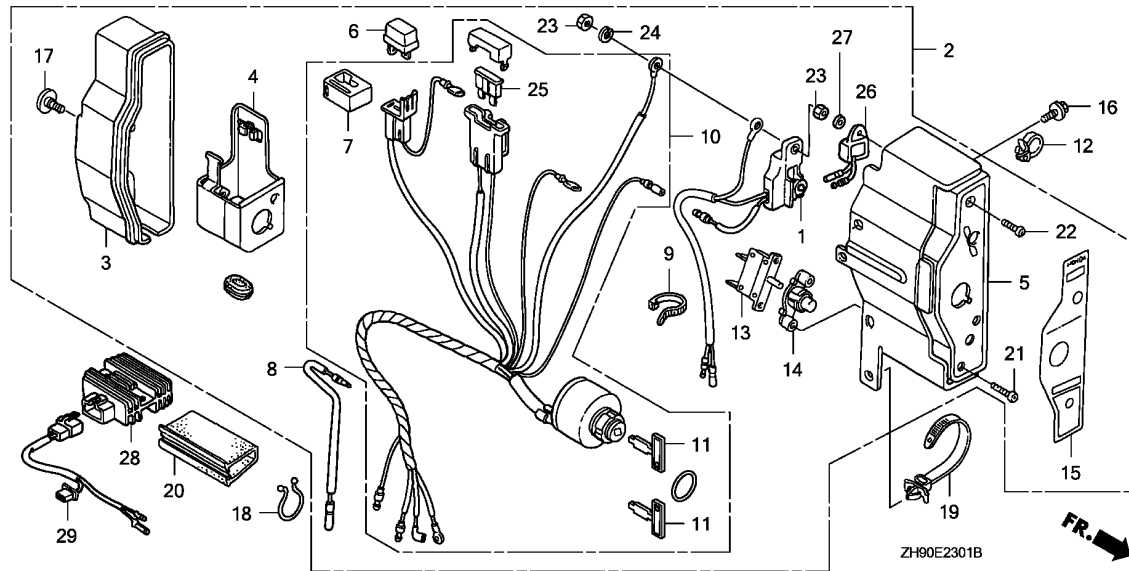

Ref. No.	L.O.N.	(Relative ref. Number) Description	F.R.T.
1	6151K4	ALERT UNIT, ENGINE CONTROL OIL	0.2
2	6221N7	BOX, ENGINE CONTROL	0.1
6	6131B8	RECTIFIER, SILICON	0.1
10	6151E1	SWITCH, COMBINATION	0.2
13	6221D4	PROTECTOR, CIRCUIT	0.2
25	8121A7	FUSE, BLADE	0.1
28	6131B7	RECTIFIER, REGULATOR	0.2
29	6111E6	HARNESS, REGULATOR RECTIFIER	0.2

2

Ref. No.	Part No.	Description	Reqd. QTY			Serial No.	Parts catalogue code
			(1)	(2)	(3)		
1	15520-ZE2-822	ALERT UNIT, OIL (SEL)	1	(1)	-	1033679	L1,QAЕ,QXЕ,QXEB,Q1,R1,SXЕ,SXEB,S1,VXЕ,VXEB,V1,W1
2	31610-ZE2-822ZB	BOX ASSY., CONTROL (INTERNAL-ALERT)	1	(1)	-	1033679	L1,Q1,R1,S1,V1,W1
		R8.....BRIGHT RED	-	(1)	-	1033679	L1,QXЕ,QXEB,Q1,R1,SXЕ,SXEB,S1,VXЕ,VXEB,V1,W1
	31610-ZE2-832ZB	BOX ASSY., CONTROL (ALERT)	1	(1)	-	1033679	L1,QAЕ,Q1,R1,S1,V1,W1
		R8.....BRIGHT RED	-	(1)	-	1033679	L1,QXЕ,QXEB,Q1,R1,SXЕ,SXEB,S1,VXЕ,VXEB,V1,W1
	31610-ZE2-842ZB	BOX ASSY., CONTROL (3A)	1	(1)	-	1033679	L1,QAЕ,Q1,R1,S1,V1,W1
		R8.....BRIGHT RED	-	(1)	-	1033679	L1,QAЕ,Q1,R1,S1,V1,W1
	31610-ZE2-852ZB	BOX ASSY., CONTROL (EXP-ALERT) (3A)	1	(1)	-	1033679	L1,QAЕ,Q1,R1,S1,V1,W1
		R8.....BRIGHT RED	-	(1)	-	1033679	L1,QAЕ,Q1,R1,S1,V1,W1
	31610-ZE2-853ZA	BOX ASSY., CONTROL (EXTERNAL-ALERT) (3A)	1	(1)	-	1033679	L1,QAЕ,Q1,R1,S1,V1,W1
		NH1.....BLACK	1	-	-	1321602	QAЕ2
	31610-ZE2-853ZD	*NH105*...MAT BLACK (#15-#20)	1	-	-	1321602	VME2
	31610-ZE2-862ZB	BOX ASSY., CONTROL (10A)	1	(1)	-	2085591	L1,Q1,Q2,R1,S1,V1,W1
		R8.....BRIGHT RED	-	(1)	-	2085591	L1/A,Q1/A,R1/A,S1/A,W1/A
	31610-ZE2-872ZB	BOX ASSY., CONTROL (EXP-ALERT) (10A)	1	(1)	-	1106814	L1,R1,V1,W1
		R8.....BRIGHT RED	-	(1)	-	1106814	L1,R1,V1,W1
	31610-ZH9-W51ZA	BOX ASSY., CONTROL	1	-	-	1033679	VEB6
		R8.....BRIGHT RED	1	-	-	1325304	QXЕ4,SXЕ4,VXЕ4
			1	-	-	1106356	1325304 SXEB,VXEB
	31610-ZH9-W52ZB	BOX ASSY., CONTROL (EXTERNAL-ALERT)	1	-	-	1325304	QXЕ4/A,SXEB/A,SXЕ4/A,VXEB/A,VXЕ4/A,VXЕ7/A
		NH1.....BLACK	1	-	-	1325304	VXЕ7

Ref. No.	Part No.	Description	Reqd. QTY			Serial No.	Parts catalogue code
			(1)	(2)	(3)		
(2)	31610-ZK2-W41ZA	BOX ASSY., CONTROL					
		R8.....BRIGHT RED	1	-	-	-----	QHE4,QHE4/A,RHE4,RHE4/A
	31610-ZK9-W41ZA	BOX ASSY., CONTROL (10A)					
		R8.....BRIGHT RED	1	-	-	-----	1325169 QME2,SME1
	31610-ZE2-823ZB	BOX ASSY., CONTROL					
		R8.....BRIGHT RED	-	(1)	-	-----	L1,Q1,R1,S1,V1,W1
	31610-ZE2-833ZB	*R8*.....BRIGHT RED	1	(1)	-	-----	L1,QXEB,Q1,Q2,R1,S1,VEB6,V1,W1
			1	-	-	-----	1324181 LXE,QXE6,VXE6
			1	-	-	-----	1106355 SXEB,VXEB
			1	-	-	-----	1324181 QXE,SXE,VXE
	31610-ZE2-853ZB	BOX ASSY., CONTROL (EXTERNAL-ALERT) (3A)					
		R8.....BRIGHT RED	1	(1)	-	-----	L1,QAE,Q1,Q2,R1,S1,V1,W1
			1	-	-	-----	HEA
			1	-	-	-----	1321602 HEA2,PAE2,QAE2,QAE6,VDE,VDE2
	31610-ZE2-854ZA	BOX ASSY., CONTROL (EXP-ALERT) (3A)					
		NH1.....BLACK	1	-	-	-----	QAE2/A,VME2
			1	-	-	-----	1321603 QAE2
	31610-ZE2-854ZD	*NH105*...MAT BLACK (#15-#20)	1	-	-	-----	VME2/A,VMS2
			1	-	-	-----	1321603 VME2
	31610-ZE2-862ZD	BOX ASSY., CONTROL (10A)					
		R280.....POWER RED	-	(1)	-	-----	L1/A,Q1/A,R1/A,S1/A,W1/A
	31610-ZE2-873ZB	*R8*.....BRIGHT RED	1	(1)	-	-----	QSC,Q2
			1	(1)	-	-----	1329949 QSC9,QSE,QXB6,Q1,S1
			-	(1)	-	-----	1106815 L1,R1,V1,W1
	31610-ZH9-W52ZA	BOX ASSY., CONTROL (ALERT)					
		R8.....BRIGHT RED	1	-	-	-----	1325305 QXE4,SXEB,SXE4,VXEB,VXE4,VXE7
			1	-	-	-----	2081323 QXE4/A,SXEB/A,SXE4/A,VXEB/A,VXE4/A,VXE7/A
	31610-ZK9-W42ZA	BOX ASSY., CONTROL (EXTERNAL-ALERT) (10A)					
		R8.....BRIGHT RED	1	-	-	-----	1325170 QME2,SME1
			1	-	-	-----	2085216 QME2/A,SME1/A
	31610-ZE2-824ZB	BOX ASSY., CONTROL					
		R8.....BRIGHT RED	-	(1)	-	-----	2085591 L1/A,Q1/A,R1/A,S1/A,W1/A
	31610-ZE2-834ZB	*R8*.....BRIGHT RED	1	1	-	-----	1324182 LXE,LXE8,L1,PXE8,QXE,QXE6,QXE8,Q1,Q2,R1,SXE,SXE8,S1,VXE,VXE6,V1WXE8,W1
			1	-	-	-----	2080306 LXE/A,LXE8/A,PXE8/A,QXE/A,QXE6/A,QXE8/A,SXE/A,SXE8/A,VXE6/AWXE8/A
			-	(1)	-	-----	2085591 L1/A,Q1/A,R1/A,S1/A,W1/A
	31610-ZE2-854ZB	BOX ASSY., CONTROL (EXP-ALERT) (3A)					
		R8.....BRIGHT RED	1	1	-	-----	1321603 HEA2,HEA8,L1,PAE2,QAE2,QAE6,Q1,Q2,R1,S1,VDE,VDE2,VKB2,VME2,V1,W1
			1	(1)	-	-----	HEA2/A,HEA8/A,L1/A,PAE2/A,QAE2/A,QAE6/A,Q1/A,R1/A,S1/A,VDE2/AVKB2/A,VME2/A,W1/A
	31610-ZE2-854ZF	*R280*.....POWER RED	1	-	-	-----	2081314 HEA2/A,HEA8/A,PAE2/A,QAE2/A,QAE6/A,VDE2/A,VKB2/A,VME2/A
			-	(1)	-	-----	2085592 L1/A,Q1/A,R1/A,S1/A,W1/A
	31610-ZE2-874ZB	BOX ASSY., CONTROL (10A)					
		R8.....BRIGHT RED	1	(1)	-	-----	L1/A,QSC9/A,QSE/A,QSE8/A,QXB6/A,Q1/A,R1/A,S1/A,W1/A
			1	(1)	-	-----	1329950 L1,QSC9,QSE,QSE8,QXB6,Q1,R1,S1,W1
			1	-	-	-----	1329950 2080508 QSE2
	31610-ZH9-W52ZC	BOX ASSY., CONTROL (ALERT)					
		R280.....POWER RED	1	-	-	-----	2081324 QXE4/A,SXEB/A,SXE4/A,VXEB/A,VXE4/A,VXE7/A
	31610-ZK9-W42ZC	BOX ASSY., CONTROL (EXTERNAL-ALERT) (10A)					
		R280.....POWER RED	1	-	-	-----	2085217 QME2/A,SME1/A
	31610-ZE2-824ZE	BOX ASSY., CONTROL					
		R280.....POWER RED	-	(1)	-	-----	2085592 L1/A,Q1/A,R1/A,S1/A,W1/A



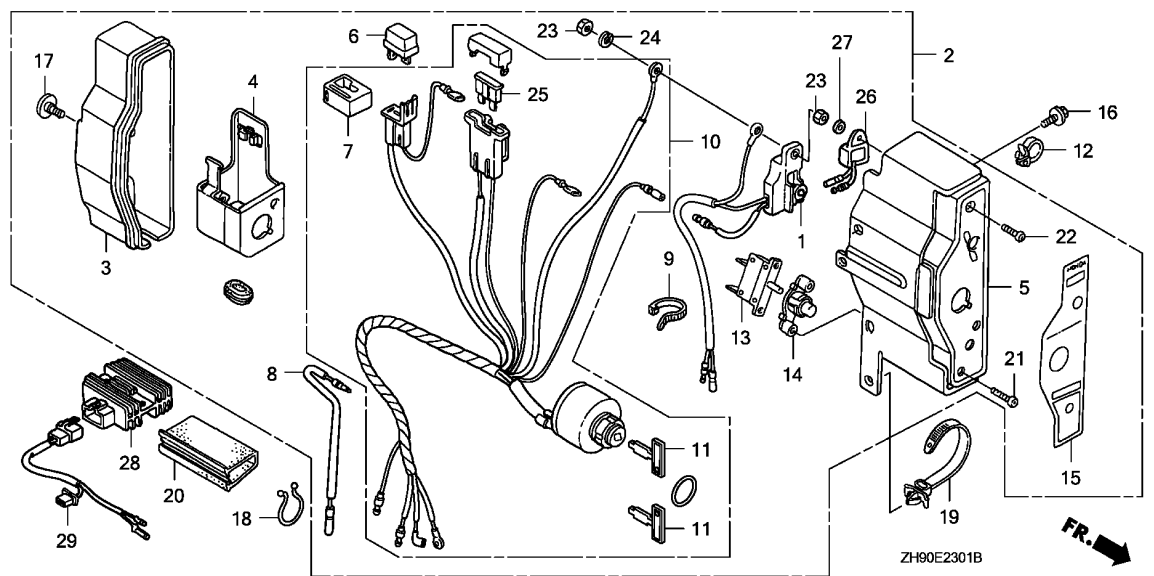

Ref. No.	Part No.	Description	Reqd. QTY			Serial No.	Parts catalogue code
			(1)	(2)	(3)		
(2)	31610-ZE2-834ZE	BOX ASSY., CONTROL (EXP-ALERT) *R280*.....POWER RED	1	-	-	-----	WMA4
			1	-	-	2080307	LXE/A,LXE8/A,PXE8/A,QXE/A,QXE6/A,QXE8/A,RA2/A,SXE/A,SXE8/A,VXE6/A WXE8/A
	31610-ZE2-874ZD	BOX ASSY., CONTROL (10A) *R280*.....POWER RED	-	(1)	-	2085592	L1/A,Q1/A,R1/A,S1/A,W1/A
3	31612-ZE2-003	CASE, CONTROL	1	-	-	2080509	QSE2
			1	-	-	-----	HEA,HEA2,HEA2/A,HEA8,HEA8/A,LXE,LXE/A,LXE8,LXE8/A,PAE2,PAE2/A PXE8,PXE8/A,QAE,QAE2,QAE2/A,QAE6,QAE6/A,QHE4,QHE4/A,QME2,QME2/A QSC,QSC9,QSC9/A,QSE,QSE/A,QSE2,QSE8,QSE8/A,QXB6,QXB6/A,QXE,QXE/A QXEB,QXE4,QXE4/A,QXE6,QXE6/A,QXE8,QXE8/A,RHE4,RHE4/A,SME1,SME1/A SXE,SXE/A,SXEB,SXEB/A,SXE4,SXE4/A,SXE8,SXE8/A,VDE,VDE2,VDE2/A VEB6,VKB2,VKB2/A,VME2,VME2/A,VMS2,VXE,VXEB,VXEB/A,VXE4,VXE4/A VXE6,VXE6/A,VXE7,VXE7/A,WMA4,WXE8,WXE8/A
4	31614-ZE2-003	BRACKET, CASE MOUNTING	-	(1)	-	-----	HEA,HEA2,HEA2/A,HEA8,HEA8/A,LXE,LXE/A,LXE8,LXE8/A,PAE2,PAE2/A PXE8,PXE8/A,QAE,QAE2,QAE2/A,QAE6,QAE6/A,QHE4,QHE4/A,QME2,QME2/A QSC,QSC9,QSC9/A,QSE,QSE/A,QSE2,QSE8,QSE8/A,QXB6,QXB6/A,QXE,QXE/A QXEB,QXE4,QXE4/A,QXE6,QXE6/A,QXE8,QXE8/A,RHE4,RHE4/A,SME1,SME1/A SXE,SXE/A,SXEB,SXEB/A,SXE4,SXE4/A,SXE8,SXE8/A,VDE,VDE2,VDE2/A VEB6,VKB2,VKB2/A,VME2,VME2/A,VMS2,VXE,VXEB,VXEB/A,VXE4,VXE4/A VXE6,VXE6/A,VXE7,VXE7/A,WMA4,WXE8,WXE8/A
5	31615-ZE2-003ZA	PANEL COMP., CONTROL *NH1*.....BLACK	1	-	-	-----	HEA2/A,QAE2,QAE2/A,QAE6/A,QXE4/A,SXEB/A,SXE4/A,VDE2/A,VME2,VXEB/A VXE4/A,VXE7,VXE7/A

Ref. No.	Part No.	Description	Reqd. QTY			Serial No.	Parts catalogue code
			(1)	(2)	(3)		
(5)	31615-ZE2-003ZB	PANEL COMP., CONTROL *R8*.....BRIGHT RED	1	-	-		HEA,HEA2,HEA8,LXE,LXE8,PAE2,PXE8,QAE,QAE2,QAE6,QHE4,QME2,QSC,QSC9,QSE,QSE8,QXB6,QXE,QXEB,QXE4,QXE6,QXE8,RHE4,SME1,SXE,SXE/A,SXEB,SXE4,SXE8,VDE,VDE2,VEB6,VKB2,VME2,VXE,VXEB,VXE4,VXE6,VXE7,WXE8
			1	-	-	2080508	HEA2/A,HEA8/A,LXE/A,LXE8/A,PAE2/A,PXE8/A,QAE2/A,QAE6/A,QHE4/A,QME2/A,QSC9/A,QSE/A,QSE2,QSE8/A,QXB6/A,QXE/A,QXE4/A,QXE6/A,QXE8/A,RHE4/A,SME1/A,SXEB/A,SXE4/A,SXE8/A,VDE2/A,VKB2/A,VME2/A,VXEB/A,VXE4/A,VXE6/A,VXE7/A,WXE8/A
	31615-ZE2-003ZE	*NH105*...MAT BLACK (#15-#20)	1	(1)	-		VME2,VME2/A,VMS2
	31615-ZE2-003ZG	*R280*.....POWER RED	1	(1)	-	2080509	HEA2/A,HEA8/A,LXE/A,LXE8/A,L1/A,PAE2/A,PXE8/A,QAE2/A,QAE6/A,QHE4/A,QME2/A,QSC9/A,QSE/A,QSE2,QSE8/A,QXB6/A,QXE/A,QXE4/A,QXE6/A,QXE8/A,Q1/A,RHE4/A,R1/A,SME1/A,SXE/A,SXEB/A,SXE4/A,SXE8/A,S1/A,VDE2/A,VKB2/A,VME2/A,VXEB/A,VXE4/A,VXE6/A,VXE7/A,WXE8/A,W1/A
			1	-	-		WMA4
6	31700-124-008	RECTIFIER ASSY., SILICON (SHINDENGEN)	1	-	-		HEA,HEA2,HEA2/A,HEA8,HEA8/A,LXE,LXE/A,LXE8,LXE8/A,PAE2,PAE2/A,PXE8,PXE8/A,QAE,QAE2,QAE2/A,QAE6,QAE6/A,QHE4,QHE4/A,QXE,QXE/A,QXEB,QXE4,QXE4/A,QXE6,QXE6/A,QXE8,QXE8/A,RHE4,RHE4/A,SXE,SXE/A,SXEB,SXEB/A,SXE4,SXE4/A,SXE8,SXE8/A,VDE,VDE2,VDE2/A,VEB6,VKB2,VKB2/A,VKE4,VME2,VME2/A,VMS2,VXE,VXEB,VXEB/A,VXE4,VXE4/A,VXE6,VXE6/A,VXE7,VXE7/A,WMA4,WXE8,WXE8/A
7	32127-738-700	SUSPENSION, COUPLER	1	(1)	-		HEA,HEA2,HEA2/A,HEA8,HEA8/A,LXE,LXE/A,LXE8,LXE8/A,PAE2,PAE2/A,PXE8,PXE8/A,QAE,QAE2,QAE2/A,QAE6,QAE6/A,QHE4,QHE4/A,QXE,QXE/A,QXEB,QXE4,QXE4/A,QXE6,QXE6/A,QXE8,QXE8/A,RHE4,RHE4/A,SXE,SXE/A,SXEB,SXEB/A,SXE4,SXE4/A,SXE8,SXE8/A,VDE,VDE2,VDE2/A,VEB6,VKB2,VKB2/A,VKE4,VME2,VME2/A,VMS2,VXE,VXEB,VXEB/A,VXE4,VXE4/A,VXE6,VXE6/A,VXE7,VXE7/A,WMA4,WXE8,WXE8/A
8	32197-ZE1-003	SUB HARNESS	1	(1)	-		HEA,HEA2,HEA2/A,HEA8,HEA8/A,LXE,LXE/A,LXE8,LXE8/A,PAE2,PAE2/A,PXE8,PXE8/A,QAE2,QAE2/A,QAE6,QAE6/A,QME2/A,QSC,QSC9,QSC9/A,QSE/A,QSE2,QSE8/A,QXB6/A,QXE/A,QXE4/A,QXE6,QXE6/A,QXE8,QXE8/A,SME1/A,SXE/A,SXEB/A,SXE4/A,SXE8/A,VDE,VDE2,VDE2/A,VEB6,VKB2,VKB2/A,VME2,VME2/A,VMS2,VXEB/A,VXE4/A,VXE6,VXE6/A,VXE7,VXE7/A,WMA4,WXE8,WXE8/A
			1	-	-	1033680	QAE
			1	-	-	1127487	SXEB,VXEB
			1	-	-	1321603	QME2,QSE,QSE8,QXB6,QXE,QXE4,SME1,SXE,SXE4,SXE8,VXE4
9	32902-892-003	BAND	1	-	-		HEA,HEA2,HEA2/A,HEA8,HEA8/A,LXE,LXE/A,LXE8,LXE8/A,PAE2,PAE2/A,PXE8,PXE8/A,QAE,QAE2,QAE2/A,QAE6,QAE6/A,QHE4,QHE4/A,QME2,QME2/A,QSC,QSC9,QSC9/A,QSE,QSE/A,QSE2,QSE8,QSE8/A,QXB6,QXB6/A,QXE,QXE/A,QXEB,QXE4,QXE4/A,QXE6,QXE6/A,QXE8,QXE8/A,RHE4,RHE4/A,SME1,SME1/A,SXE,SXE/A,SXEB,SXEB/A,SXE4,SXE4/A,SXE8,SXE8/A,VDE,VDE2,VDE2/A,VEB6,VKB2,VKB2/A,VME2,VME2/A,VMS2,VXEB/A,VXE4/VXE6,VXE6/A,VXE7,VXE7/A,WMA4,WXE8,WXE8/A
10	35100-ZE2-023	SWITCH ASSY., COMBINATION ...	1	(1)	-		LXE,LXE/A,LXE8,LXE8/A,PXE8,PXE8/A,QHE4,QHE4/A,QXE,QXE/A,QXEB,QXE4,QXE4/A,QXE6,QXE6/A,QXE8,QXE8/A,RHE4,RHE4/A,SXE,SXE/A,SXEB,SXEB/A,SXE4,SXE4/A,SXE8,SXE8/A,VEB6,VXE,VXEB,VXEB/A,VXE4,VXE4/A,VXE6,VXE6/A,VXE7,VXE7/A,WMA4,WXE8,WXE8/A
	35100-ZE2-842	SWITCH ASSY., COMBINATION (3A-CHARGE)	1	(1)	-		HEA,HEA2,HEA2/A,HEA8,HEA8/A,L1,L1/A,PAE2,PAE2/A,QAE,QAE2,QAE2/A,QAE6,QAE6/A,Q1,Q1/A,Q2,R1/R1/A,VDE,VDE2,VDE2/A,VKB2,VKB2/A,VKE4,VME2,VME2/A,VMS2,V1,W1,W1/A



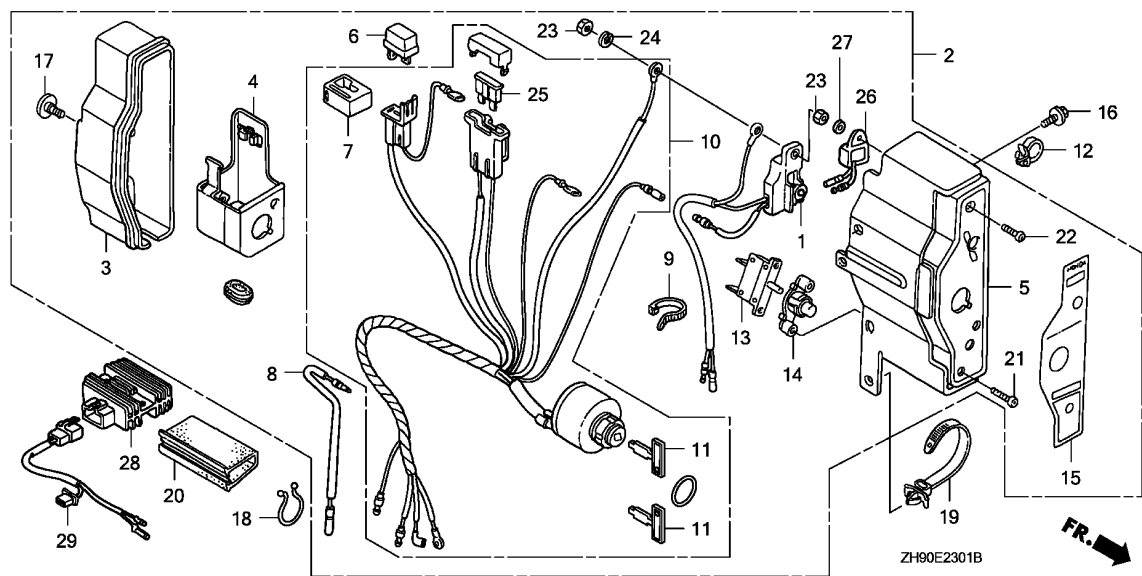

Ref. No.	Part No.	Description	Reqd. QTY			Serial No.	Parts catalogue code
			(1)	(2)	(3)		
10)	35100-ZE2-862	SWITCH ASSY., COMBINATION (10A-CHARGE)	1	(1)	-	-----	L1,L1/A,QME2,QME2/A,QSC,QSC9,QSC9/A,QSE,QSE/A,QSE2,QSE8,QSE8/A,QXB6,QXB6/A,Q1,Q1/A,Q2,R1,R1/A,SME1,SME1/A,V1,W1,W1/A
11	35111-880-003	KEY COMP.	2	-	-	-----	HEA,HEA2,HEA2/A,HEA8,HEA8/A,LXE,LXE/A,LXE8,LXE8/A,PAE2,PAE2/A,PXE8,PXE8/A,QAE,QAE2,QAE2/A,QAE6,QAE6/A,QHE4,QHE4/A,QME2,QME2/A,QSC,QSC9,QSC9/A,QSE,QSE/A,QSE2,QSE8,QSE8/A,QXB6,QXB6/A,QXE,QXE/A,QXEB,QXE4,QXE4/A,QXE6,QXE6/A,QXE8,QXE8/A,RHE4,RHE4/A,SME1,SME1/A,SXE,SXE/A,SXEB,SXEB/A,SXE4,SXE4/A,SXE8,SXE8/A,VDE,VDE2,VDE2/A,VEB6,VKB2,VKB2/A,VKE4,VME2,VME2/A,VXE,VXEB,VXEB/A,VXE4,VXE4/A,VXE6,VXE6/A,VXE7,VXE7/A,WXE8,WXE8/A
			2	-	-	2233813	VMS2
			-	(2)	-	-----	
	35111-880-013	2	-	-	-----	WMA4
			2	-	-	2233814	VMS2
12	36103-ZE1-000	HOLDER, STOP SWITCH CORD	1	-	-	-----	HEA,HEA2,HEA2/A,HEA8,HEA8/A,LXE,LXE/A,LXE8,LXE8/A,PAE2,PAE2/A,PXE8,PXE8/A,QAE,QAE2,QAE2/A,QAE6,QAE6/A,QHE4,QHE4/A,QME2,QME2/A,QSC,QSC9,QSC9/A,QSE,QSE/A,QSE2,QSE8,QSE8/A,QXB6,QXB6/A,QXE,QXE/A,QXEB,QXE4,QXE4/A,QXE6,QXE6/A,QXE8,QXE8/A,RHE4,RHE4/A,SME1,SME1/A,SXE,SXE/A,SXEB,SXEB/A,SXE4,SXE4/A,SXE8,SXE8/A,VDE,VDE2,VDE2/A,VEB6,VKB2,VKB2/A,VME2,VME2/A,VMS2,VXE,VXEB,VXEB/A,VXE4,VXE4/A,VXE6,VXE6/A,VXE7,VXE7/A,WMA4,WXE8,WXE8/A
13	38240-VA3-900	PROTECTOR, CIRCUIT (1.0A) ...	-	(1)	-	-----	LXE,LXE/A,LXE8,LXE8/A,PXE8,PXE8/A,QHE4,QHE4/A,QXE,QXE/A,QXEB,QXE4,QXE4/A,QXE6,QXE6/A,QXE8,QXE8/A,RHE4,RHE4/A,SXE,SXE/A,SXEB,SXEB/A,SXE4,SXE4/A,SXE8,SXE8/A,VEB6,VXE,VXEB,VXEB/A,VXE4,VXE4/A,VXE6,VXE6/A,VXE7,VXE7/A,WMA4,WXE8,WXE8/A
			-	(1)	-	-----	

2

Ref. No.	Part No.	Description	Reqd. QTY			Serial No.	Parts catalogue code
			(1)	(2)	(3)		
13)	38240-ZE2-840	PROTECTOR, CIRCUIT (3.5A) ...	1	(1)	-	-----	HEA,HEA2,HEA2/A,HEA8,HEA8/A,L1,L1/A,PAE2,PAE2/A,QAE,QAE2,QAE2/A,QAE6,QAE6/A,Q1,Q1/A,Q2,R1,R1/A,VDE,VDE2,VDE2/A,VKB2,VKB2/A,VME2,VME2/A,VMS2,V1,W1,W1/A
14	38250-ZA8-701	LENS ASSY., PROTECTOR	1	-	-	-----	HEA,HEA2,HEA2/A,HEA8,HEA8/A,LXE,LXE/A,LXE8,LXE8/A,PAE2,PAE2/A,PXE8,PXE8/A,QAE,QAE2,QAE2/A,QAE6,QAE6/A,QHE4,QHE4/A,QXE,QXE/A,QXEB,QXE4,QXE4/A,QXE6,QXE6/A,QXE8,QXE8/A,RHE4,RHE4/A,SXE,SXE/A,SXEB,SXEB/A,SXE4,SXE4/A,SXE8,SXE8/A,VDE,VDE2,VDE2/A,VEB6,VKB2,VKB2/A,VME2,VME2/A,VMS2,VXE,VXEB,VXEB/A,VXE4,VXE4/A,VXE6,VXE6/A,VXE7,VXE7/A,WMA4,WXE8,WXE8/A
15	87529-ZE2-831	PANEL, CONTROL BOX (EXTERNAL-ALERT)	1	(1)	-	-----	1033679 L1,QAE,QXE,QXEB,Q1,R1,SXE,SXEB,VXE,VXEB,V1,W1
	87529-ZE2-010	PANEL, CONTROL BOX (INTERNAL)	-	(1)	-	-----	Q1/A,W1/A
			-	(1)	-	-----	1033680 L1,Q1,R1,S1,V1,W1
			-	(1)	-	-----	2165395 L1/A,R1/A,S1/A
	87529-ZE2-811	MARK, CONTROL BOX (EXTERNAL)	1	1	-	-----	HEA,HEA2,HEA8,LXE,LXE8,L1/A,PAE2,PXE8,QAE2,QAE6,QXE6,QXE8,Q1/A,R1/A,SXE8,VDE,VDE2,VKB2,VME2,VXE6,WXE8,W1/A
			1	1	-	-----	1033680 L1,QAE,QXE,QXEB,Q1,Q2,R1,SXE,VEB6,VXE,V1,W1
			1	-	-	-----	2151454 HEA2/A,HEA8/A,LXE/A,LXE8/A,PAE2/A,PXE8/A,QAE2/A,QAE6/A,QXE/A,QXE6/A,QXE8/A,SXE/A,SXE8/A,VDE2/A,VKB2/A,VME2/A,VXE6/A,WXE8/A
			1	-	-	-----	1033680 1127486 SXEB,VXEB
	87529-ZE2-821	PANEL, CONTROL BOX (INTERNAL-ALERT)	-	(1)	-	-----	1033679 L1,Q1,R1,S1,V1,W1
	87529-ZE2-860	MARK, CONTROL BOX (EXTERNAL-REGULATOR)	1	(1)	-	-----	L1,L1/A,QSC,QSC9,QSE,QSE8,QXB6,Q1,Q2,R1,R1/A,V1,W1,W1/A
			1	(1)	-	-----	2165395 QSC9/A,QSE/A,QSE2,QSE8/A,QXB6/A,Q1/A
	87529-ZE2-870	MARK, CONTROL BOX (EXTERNAL-ALERT)(REGULATOR)	-	(1)	-	-----	1033679 L1,Q1,Q2,R1,V1,W1
	87529-ZH8-W40	MARK, CONTROL BOX (ENGLISH) -	1	-	-	-----	QME2,SME1
			1	-	-	-----	2153922 QME2/A,SME1/A
	87529-ZH9-W40	1	-	-	-----	QHE4,QXE4,RHE4,SXE4,VXE4,VXE7
			1	-	-	-----	1127487 SXEB,VXEB
			1	-	-	-----	1033679 VEB6
			1	-	-	-----	2155785 QHE4/A,QXE4/A,RHE4/A,SXEB/A,SXE4/A,VXEB/A,VXE4/A,VXE7/A
	87529-ZE2-020	PANEL, CONTROL BOX (INTERNAL)	-	(1)	-	-----	2165396 L1/A,R1/A,S1/A
	87529-ZE2-812	MARK, CONTROL BOX (EXP)	1	-	-	-----	VMS2,WMA4
			1	-	-	-----	2151455 HEA2/A,HEA8/A,LXE/A,LXE8/A,PAE2/A,PXE8/A,QAE2/A,QAE6/A,QXE/A,QXE6/A,QXE8/A,SXE/A,SXE8/A,VDE2/A,VKB2/A,VME2/A,VXE6/A,WXE8/A
	87529-ZE2-861	MARK, CONTROL BOX (EXTERNAL-REGULATOR)	1	(1)	-	-----	2165396 QSC9/A,QSE/A,QSE2,QSE8/A,QXB6/A,Q1/A
	87529-ZH8-W41	MARK, CONTROL BOX (ENGLISH) -	1	-	-	-----	2153923 QME2/A,SME1/A
	87529-ZH9-W41	1	-	-	-----	2155786 QHE4/A,QXE4/A,RHE4/A,SXEB/A,SXE4/A,VXEB/A,VXE4/A,VXE7/A
16	90013-883-000	BOLT, FLANGE, 6X12(CT200) ...	2	-	-	-----	HEA,HEA2,HEA2/A,HEA8,HEA8/A,LXE,LXE/A,LXE8,LXE8/A,PAE2,PAE2/A,PXE8,PXE8/A,QAE,QAE2,QAE2/A,QAE6,QAE6/A,QHE4,QHE4/A,QME2,QME2/A,QSC,QSC9,QSC9/A,QSE,QSE/A,QSE2,QSE8,QSE8/A,QXB6,QXB6/A,QXE,QXE/A,QXEB,QXE4,QXE4/A,QXE6,QXE6/A,QXE8,QXE8/A,RHE4,RHE4/A,SME1,SME1/A,SXE,SXE/A,SXEB,SXEB/A,SXE4,SXE4/A,SXE8,SXE8/A,VDE,VDE2,VDE2/A,VEB6,VKB2,VKB2/A,VME2,VME2/A,VMS2,VXE,VXEB,VXEB/A,VXE4,VXE4/A,VXE6,VXE6/A,VXE7,VXE7/A,WMA4,WXE8,WXE8/A
			-	(2)	-	-----	



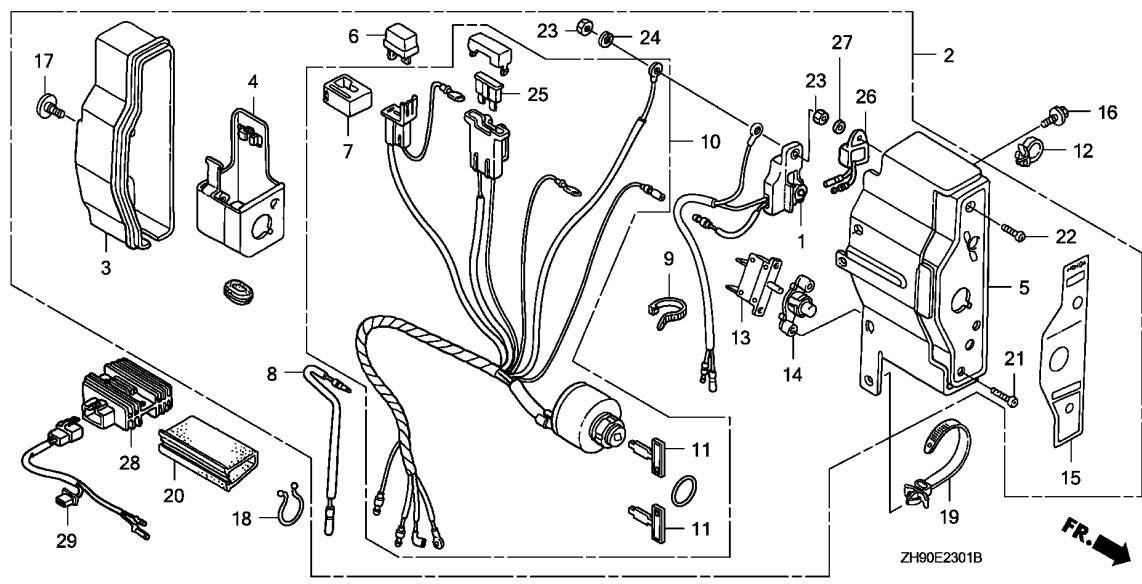

Ref. No.	Part No.	Description	Reqd. QTY			Serial No.	Parts catalogue code
			(1)	(2)	(3)		
17	90380-MA6-010	SCREW, SPECIAL, 6X12	1	-	-	HEA,HEA2,HEA2/A,HEA8,HEA8/A,LXE,LXE/A,LXE8,LXE8/A,PAE2,PAE2/A,PXE8,PXE8/A,QAE,QAE2,QAE2/A,QAE6,QAE6/A,QHE4,QHE4/A,QME2,QME2/A,QSC,QSC9,QSC9/A,QSE,QSE/A,QSE2,QSE8,QSE8/A,QXB6,QXB6/A,QXE,QXE/A,QXEB,QXE4,QXE4/A,QXE6,QXE6/A,QXE8,QXE8/A,RHE4,RHE4/A,SME1,SME1/A,SXE,SXE/A,SXEB,SXEB/A,SXE4,SXE4/A,SXE8,SXE8/A,VDE,VDE2,VDE2/A,VEB6,VKB2,VKB2/A,VME2,VME2/A,VMS2,VXE,VXEB,VXEB/A,VXE4,VXE4/A,VXE6,VXE6/A,VXE7,VXE7/A,WMA4,WXE8,WXE8/A	
18	90630-751-000	CLIP, PURSE LOCK	1	(1)	-	HEA,HEA2,HEA2/A,HEA8,HEA8/A,LXE,LXE/A,LXE8,LXE8/A,PAE2,PAE2/A,PXE8,PXE8/A,QAE,QAE2,QAE2/A,QAE6,QAE6/A,QHE4,QHE4/A,QME2,QME2/A,QSC,QSC9,QSC9/A,QSE,QSE/A,QSE2,QSE8,QSE8/A,QXB6,QXB6/A,QXE,QXE/A,QXEB,QXE4,QXE4/A,QXE6,QXE6/A,QXE8,QXE8/A,RHE4,RHE4/A,SME1,SME1/A,SXE,SXE/A,SXEB,SXEB/A,SXE4,SXE4/A,SXE8,SXE8/A,VDE,VDE2,VDE2/A,VEB6,VKB2,VKB2/A,VME2,VME2/A,VMS2,VXE,VXEB,VXEB/A,VXE4,VXE4/A,VXE6,VXE6/A,VXE7,VXE7/A,WMA4,WXE8,WXE8/A	
19	90672-SAO-003	STRAP, CABLE, 118MM(BLACK)	1	(1)	-	HEA,HEA2,HEA2/A,HEA8,HEA8/A,LXE,LXE/A,LXE8,LXE8/A,PAE2,PAE2/A,PXE8,PXE8/A,QAE,QAE2,QAE2/A,QAE6,QAE6/A,QHE4,QHE4/A,QME2,QME2/A,QSC,QSC9,QSC9/A,QSE,QSE/A,QSE2,QSE8,QSE8/A,QXB6,QXB6/A,QXE,QXE/A,QXEB,QXE4,QXE4/A,QXE6,QXE6/A,QXE8,QXE8/A,RHE4,RHE4/A,SME1,SME1/A,SXE,SXE/A,SXEB,SXEB/A,SXE4,SXE4/A,SXE8,SXE8/A,VDE,VDE2,VDE2/A,VEB6,VKB2,VKB2/A,VME2,VME2/A,VMS2,VXE,VXEB,VXEB/A,VXE4,VXE4/A,VXE6,VXE6/A,VXE7,VXE7/A,WMA4,WXE8,WXE8/A	
			-	(1)	-		



Ref. No.	Part No.	Description	Reqd. QTY			Serial No.	Parts catalogue code
			(1)	(2)	(3)		
20	91406-ZE2-003	TUBE, FASTENER, 30MM	1	-	-	HEA, HEA2, HEA2/A, HEA8, HEA8/A, LXE, LXE/A, LXE8, LXE8/A, PAE2, PAE2/A, PXE8, PXE8/A, QAE, QAE2, QAE2/A, QAE6, QAE6/A, QHE4, QHE4/A, QME2, QME2/A, QSC, QSC9, QSC9/A, QSE, QSE/A, QSE2, QSE8, QSE8/A, QXB6, QXB6/A, QXE, QXE/A, QXEB, QXE4, QXE4/A, QXE6, QXE6/A, QXE8, QXE8/A, RHE4, RHE4/A, SME1, SME1/A, SXE, SXE/A, SXEB, SXEB/A, SXE4, SXE4/A, SXE8, SXE8/A, VDE, VDE2, VDE2/A, VEB6, VKB2, VKB2/A, VME2, VME2/A, VMS2, VXE, VXEB, VXEB/A, VXE4, VXE4/A, VXE6, VXE6/A, VXE7, VXE7/A, WMA4, WXE8, WXE8/A	
			-	(1)	-		
21	93500-03012-0H	SCREW, PAN, 3X12	2	-	-	HEA, HEA2, HEA2/A, HEA8, HEA8/A, LXE, LXE/A, LXE8, LXE8/A, PAE2, PAE2/A, PXE8, PXE8/A, QAE, QAE2, QAE2/A, QAE6, QAE6/A, QHE4, QHE4/A, QXE, QXE/A, QXEB, QXE4, QXE4/A, QXE6, QXE6/A, QXE8, QXE8/A, RHE4, RHE4/A, SXE, SXE/A, SXEB, SXEB/A, SXE4, SXE4/A, SXE8, SXE8/A, VDE, VDE2, VDE2/A, VEB6, VKB2, VKB2/A, VME2, VME2/A, VMS2, VXE, VXEB, VXEB/A, VXE4, VXE4/A, VXE6, VXE6/A, VXE7, VXE7/A, WMA4, WXE8, WXE8/A	
			-	(2)	-		
22	93500-04012-0H	SCREW, PAN, 4X12	1	-	-	HEA, HEA2, HEA2/A, HEA8, HEA8/A, LXE, LXE/A, LXE8, LXE8/A, PAE2, PAE2/A, PXE8, PXE8/A, QAE, QAE2, QAE2/A, QAE6, QAE6/A, QHE4, QHE4/A, QME2, QME2/A, QSC, QSC9, QSC9/A, QSE, QSE/A, QSE2, QSE8, QSE8/A, QXB6, QXB6/A, QXE, QXE/A, QXEB, QXE4, QXE4/A, QXE6, QXE6/A, QXE8, QXE8/A, RHE4, RHE4/A, SME1, SME1/A, SXE, SXE/A, SXEB, SXEB/A, SXE4, SXE4/A, SXE8, SXE8/A, VDE, VDE2, VDE2/A, VEB6, VKB2, VKB2/A, VME2, VME2/A, VMS2, VXE, VXEB, VXEB/A, VXE4, VXE4/A, VXE6, VXE6/A, VXE7, VXE7/A, WMA4, WXE8, WXE8/A	
			-	(1)	-		
23	94001-04390-0S	NUT, HEX., 4MM	1	(1)	-	HEA, QAE, QHE4, QHE4/A, QSC, RHE4, RHE4/A, V1, W1	
			1	(1)	-	1321602 HEA2, HEA8, L1, PAE2, QAE2, QAE6, Q1, Q2, R1, S1, VDE, VDE2, VKB2, VME2	
			1	-	-	1324181 LXE, LXE8, PXE8, QXE, QXEB, QXE6, QXE8, SXE, SXE8, VEB6, VXE, VXE6, VX26, WXE8	
			1	-	-	1325169 QME2, SME1	
			1	-	-	1325304 QXE4, SXEB, SXE4, VXEB, VXE4, VXE7	
			1	-	-	1329949 QSC9, QSE, QSE2, QSE8, QXB6	
			2	(2)	-	HEA2/A, HEA8/A, LXE/A, LXE8/A, L1/A, PAE2/A, PXE8/A, QAE2/A, QAE6/A, QME2/A, QSC9/A, QSE/A, QSE8/A, QXB6/A, QXE/A, QXE4/A, QXE6/A, QXE8/A, Q1/A, R1/A, SME1/A, SXE/A, SXEB/A, SXE4/A, SXE8/A, S1/A, VDE2/A, VKB2/A, VME2/A, VMS2, VXEB/A, VXE4/A, VXE6/A, VXE7/A, WMA4, WXE8/A, W1/A	
			2	(2)	-	1321603 HEA2, HEA8, L1, PAE2, QAE2, QAE6, Q1, Q2, R1, S1, VDE, VDE2, VKB2, VME2	
			2	-	-	1324182 LXE, LXE8, PXE8, QXE, QXEB, QXE6, QXE8, SXE, SXE8, VEB6, VXE, VXE6, VX26, WXE8	
			2	-	-	1325170 QME2, SME1	
			2	-	-	1325305 QXE4, SXEB, SXE4, VXEB, VXE4, VXE7	
			2	-	-	1329950 QSC9, QSE, QSE2, QSE8, QXB6	
24	94111-04800	WASHER, SPRING, 4MM	1	-	-	HEA, HEA2, HEA2/A, HEA8, HEA8/A, LXE, LXE/A, LXE8, LXE8/A, PAE2, PAE2/A, PXE8, PXE8/A, QAE, QAE2, QAE2/A, QAE6, QAE6/A, QHE4, QHE4/A, QME2, QME2/A, QSC, QSC9, QSC9/A, QSE, QSE/A, QSE2, QSE8, QSE8/A, QXB6, QXB6/A, QXE, QXE/A, QXEB, QXE4, QXE4/A, QXE6, QXE6/A, QXE8, QXE8/A, RHE4, RHE4/A, SME1, SME1/A, SXE, SXE/A, SXEB, SXEB/A, SXE4, SXE4/A, SXE8, SXE8/A, VDE, VDE2, VDE2/A, VEB6, VKB2, VKB2/A, VME2, VME2/A, VMS2, VXE, VXEB, VXEB/A, VXE4, VXE4/A, VXE6, VXE6/A, VXE7, VXE7/A, WMA4, WXE8, WXE8/A	
			-	(1)	-		
25	98200-30500	FUSE, BLADE (5A)	1	-	-	LXE, LXE/A, LXE8, LXE8/A, PXE8, PXE8/A, QHE4, QHE4/A, QXE, QXE/A, QXEB, QXE4, QXE4/A, QXE6, QXE6/A, QXE8, QXE8/A, RHE4, RHE4/A, SXE, SXE/A, SXEB, SXEB/A, SXE4, SXE4/A, SXE8, SXE8/A, VEB6, VXE, VXEB, VXEB/A, VXE4, VXE4/A, VXE6, VXE6/A, VXE7, VXE7/A, WMA4, WXE8, WXE8/A	
			-	(1)	-		
	98200-31500	FUSE, BLADE (15A)	1	(1)	-	HEA, HEA2, HEA2/A, HEA8, HEA8/A, L1, L1/A, PAE2, PAE2/A, QAE, QAE2, QAE2/A, QAE6, QAE6/A, QME2, QME2/A, QSC, QSC9, QSC9/A, QSE, QSE/A, QSE2, QSE8, QSE8/A, QXB6, QXB6/A, Q1, Q1/A, Q2, R1, R1/A, SME1, SME1/A, VDE, VDE2, VDE2/A, VKB2, VKB2/A, VKE4, VME2, VME2/A, VMS2, V1, W1, W1/A	



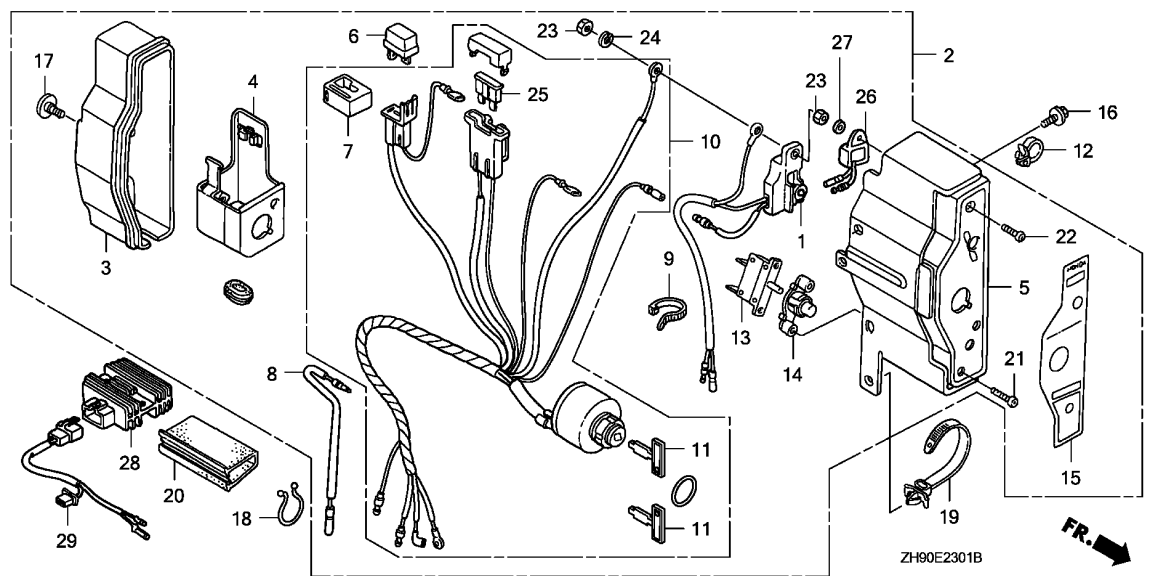

Ref. No.	Part No.	Description	Reqd. QTY			Serial No.	Parts catalogue code	
			(1)	(2)	(3)			
26	34150-ZH7-003	ALERT UNIT, OIL	1	(1)	-	HEA2/A,HEA8/A,LXE/A,LXE8/A,PAE2/A,PXE8/A,QAE2/A,QAE6/A,QME2/A,QSC9/A,QSE/A,QSE8/A,QXB6/A,QXE/A,QXE4/A,QXE6/A,QXE8/A,Q1/A,SME1/A,SXE/A,SXEB/A,SXE4/A,SXE8/A,S1/A,VDE2/A,VKB2/A,VME2/A,VMS2,VXEB/A,VXE4/A,VXE6/A,VXE7/A,WMA4,WXE8/A		
			1	(1)	-	1321603	HEA2,HEA8,L1,PAE2,QAE2,QAE6,Q1,Q2,R1,S1,VDE,VDE2,VKB2,VME2,V1,W1	
			1	-	-	1324182	LXE,LXE8,PXE8,QXE,QXEB,QXE6,QXE8,SXE,SXE8,VEB6,VXE,VXE6,VX26,WXE8	
			1	-	-	1325170	QME2,SME1	
			1	-	-	1325305	QXE4,SXEB,SXE4,VXEB,VXE4,VXE7	
			1	-	-	1329950	QSC9,QSE,QSE2,QSE8,QXB6	
27	94101-04800	WASHER, PLAIN, 4MM	1	(1)	-	HEA2/A,HEA8/A,LXE/A,LXE8/A,PAE2/A,PXE8/A,QAE2/A,QAE6/A,QME2/A,QSC9/A,QSE/A,QSE8/A,QXB6/A,QXE/A,QXE4/A,QXE6/A,QXE8/A,Q1/A,SME1/A,SXE/A,SXEB/A,SXE4/A,SXE8/A,S1/A,VDE2/A,VKB2/A,VME2/A,VMS2,VXEB/A,VXE4/A,VXE6/A,VXE7/VXE7/A,WMA4,WXE8/A		
			1	(1)	-	1321603	HEA2,HEA8,L1,PAE2,QAE2,QAE6,Q1,Q2,R1,S1,VDE,VDE2,VKB2,VME2,V1,W1	
			1	-	-	1324182	LXE,LXE8,PXE8,QXE,QXEB,QXE6,QXE8,SXE,SXE8,VEB6,VXE,VXE6,VX26,WXE8	
			1	-	-	1325170	QME2,SME1	
			1	-	-	1325305	QXE4,SXEB,SXE4,VXEB,VXE4	
			1	-	-	1329950	QSC9,QSE,QSE2,QSE8,QXB6	
28	31600-ZE2-861	RECTIFIER ASSY., REGULATOR (10A)	1	(1)	-	L1,L1/A,QHR4,QHR4/A,QKE3,QKE3/A,QKE4,QME2,QME2/A,QSC,QSE,QSE/A,QSE2,QSE8,QSE8/A,QXB6,QXB6/A,Q1,Q1/A,Q2,R1,R1/A,SME1,SME1/A,V1,W1,W1/A		
			1	-	-	1241083	QSC9	
29	32110-ZE2-860	HARNESS ASSY., SUB WIRE	1	(1)	-	L1,L1/A,QHR4,QHR4/A,QKE3,QKE3/A,QKE4,QME2,QME2/A,QSC,QSE,QSE/A,QSE2,QSE8,QSE8/A,QXB6,QXB6/A,Q1,Q1/A,Q2,R1,R1/A,SME1,SME1/A,V1,W1,W1/A		
			1	-	-	1241083	QSC9	

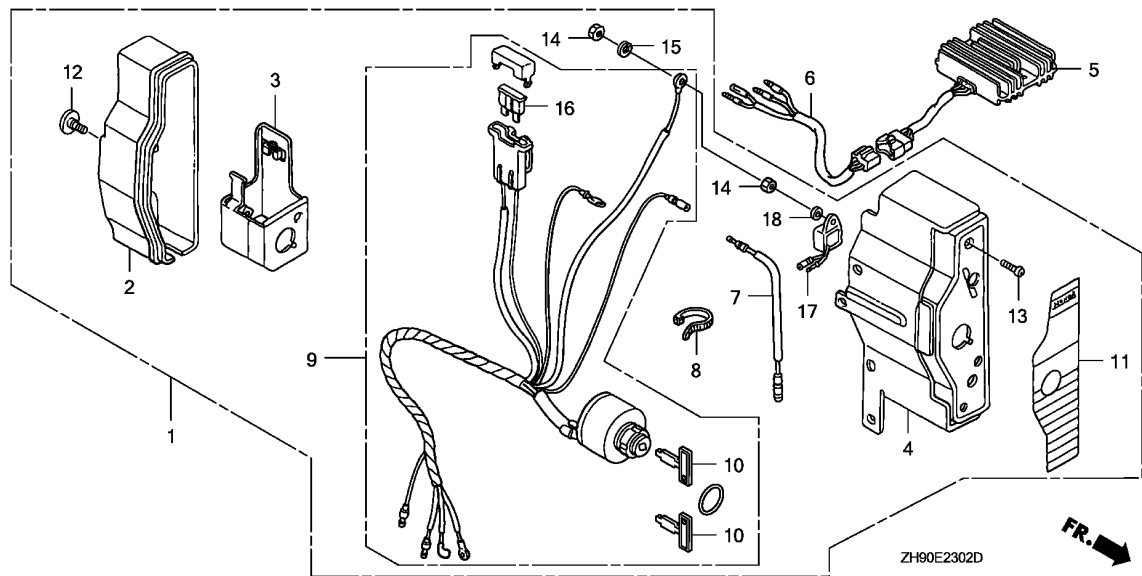

Ref. No.	L.O.N.	(Relative ref. Number) Description	F.R.T.
1	6221N7	BOX, ENGINE CONTROL	0.1
5	6131B7	RECTIFIER, REGULATOR	0.2
6	6111E7	HARNESS, REGULATOR RECTIFIER (A)	0.1
9	6151E1	SWITCH, COMBINATION	0.2
16	8121A7	FUSE, BLADE	0.1
17	6151K4	ALERT UNIT, ENGINE CONTROL OIL	0.2

Ref. No.	Part No.	Description	Reqd. QTY			Serial No.	Parts catalogue code
			(1)	(2)	(3)		
1	31610-ZE2-W01ZC	BOX ASSY., CONTROL (EXTERNAL-ALERT) (18A)	-	(1)	-	1321602	L1,Q1,Q2,R1,S1,V1,W1
		R8.....BRIGHT RED	-	(1)	-		
	31610-ZE2-W02ZC	BOX ASSY., CONTROL (EXP-ALERT) (18A)	-	(1)	-	1321603	L1,Q1,Q2,R1,S1,V1,W1
		R8.....BRIGHT RED	-	(1)	-		
	31610-ZE2-W02ZE	*R280*.....POWER RED	-	(1)	-	2085591	L1/A,Q1/A,R1/A,S1/A,W1/A
2	31612-ZE2-003	CASE, CONTROL	-	(1)	-		
3	31614-ZE2-003	BRACKET, CASE MOUNTING	-	(1)	-		
4	31615-ZE2-003ZB	PANEL COMP., CONTROL	-	(1)	-		
		R8.....BRIGHT RED	-	(1)	-		
	31615-ZE2-003ZG	*R280*.....POWER RED	-	(1)	-	2080508	L1/A,Q1/A,R1/A,S1/A,W1/A
5	31620-ZG5-003	RECTIFIER ASSY., REGULATOR (20A)	-	(1)	-	2080509	L1/A,Q1/A,R1/A,S1/A,W1/A
			-	(1)	-		
	31620-ZG5-013	-	(1)	-		L1,Q1,Q2,R1,S1,V1,W1
			-	(1)	-		L1/A,Q1/A,R1/A,S1/A,W1/A
6	32110-ZE2-W00	HARNESS ASSY., SUB WIRE	-	(1)	-		
7	32197-ZE1-003	SUB HARNESS	-	(1)	-		
8	32902-892-003	BAND	-	(1)	-		
9	35100-ZE2-W01	SWITCH ASSY., COMBINATION (18A-CHARGE)	-	(1)	-		
10	35111-880-003	KEY COMP.	-	(2)	-		
11	87529-ZE2-860	MARK, CONTROL BOX (EXTERNAL-REGULATOR)	-	(1)	-		L1,L1/A,Q1,Q2,R1,R1/A,S1,V1,W1,W1/A
			-	(1)	-	2165395	Q1/A,S1/A
	87529-ZE2-861	-	(1)	-	2165396	Q1/A,S1/A



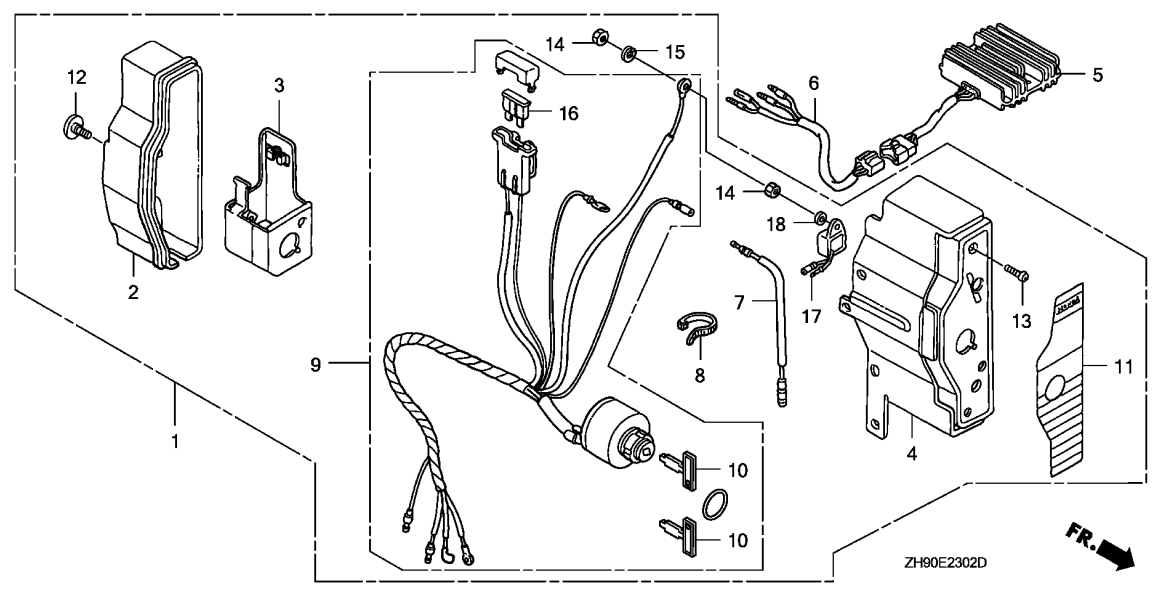

Ref. No.	Part No.	Description	Reqd. QTY			Serial No.	Parts catalogue code
			(1)	(2)	(3)		
12	90380-MA6-010	SCREW, SPECIAL, 6X12	-	(1)	-		
13	93500-04012-OH	SCREW, PAN, 4X12	-	(1)	-		
14	94001-04390-OS	NUT, HEX., 4MM	-	(1)	-	1321602	L1,Q1,Q2,R1,S1,V1,W1
			-	(2)	-		L1/A,Q1/A,R1/A,S1/A,W1/A
			-	(2)	-	1321603	L1,Q1,Q2,R1,S1,V1,W1
15	94111-04800	WASHER, SPRING, 4MM	-	(1)	-		
16	98200-32500	FUSE, BLADE (25A)	-	(1)	-		
17	34150-ZH7-003	ALERT UNIT, OIL	-	(1)	-	1321603	L1/A,Q1/A,R1/A,S1/A,W1/A
			-	(1)	-		L1,Q1,Q2,R1,S1,V1,W1
18	94101-04800	WASHER, PLAIN, 4MM	-	(1)	-	1321603	L1/A,Q1/A,R1/A,S1/A,W1/A
			-	(1)	-		L1,Q1,Q2,R1,S1,V1,W1

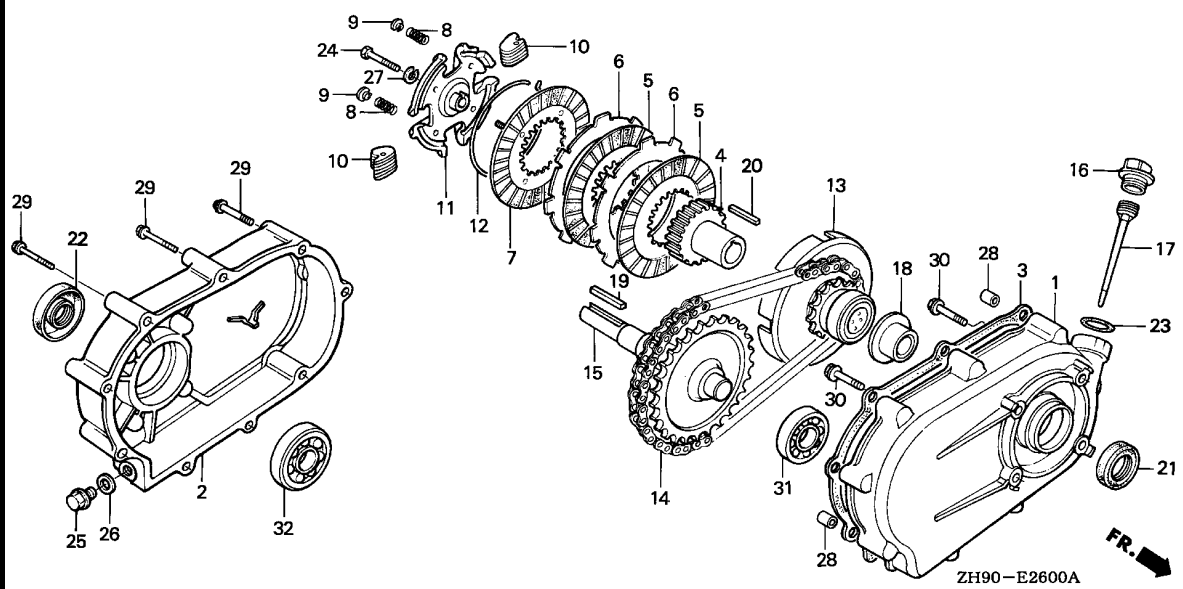

Ref. No.	L.O.N.	(Relative ref. Number) Description	F.R.T.
1	2141Y6	CASE, REDUCTION(R-TYPE)	0.4
2	2141W7	COVER, REDUCTION AND/OR PACKING, REDUCTION COVER (R-TYPE)	0.3
3	2141R2	PACKING, REDUCTION COVER	0.2
5	2141Z0	DISC, REDUCTION CLUTCH FRICTION	0.2
6	2141Z1	PLATE, REDUCTION CLUTCH	0.2
7	2141Z2	PLATE, REDUCTION CLUTCH PRESSURE	0.2
11	2121F5	(10) HOLDER, CLUTCH WEIGHT	0.2
14	2141C2	(13) CHAIN, DRIVE	0.3
15	2141H4	SHAFT, POWER TAKE OFF	0.3
21	2141AB	OIL SEAL, REDUCTION CASE	0.3
22	2141X4	OIL SEAL, POWER TAKE OFF SHAFT (R-TYPE) :REAR	0.2
31	2141Y5	BEARING, POWER TAKE OFF SHAFT (R-TYPE) :FRONT	0.4
32	2141X9	BEARING, POWER TAKE OFF SHAFT (R-TYPE) :REAR	0.3

Ref. No.	Part No.	Description	Reqd. QTY			Serial No.	Parts catalogue code
			(1)	(2)	(3)		
1	21510-889-750	CASE, REDUCTION	1	1	1	RA, RA2, RA2/A, RD, RD/A, RH, RHE, RHE4, RHE4/A, RHQ4, RHQ4/A, RH26, RH26/A, RSC2, RSC2/A, RSS, RSS/A, RX, RX/A, RXP, RXP/A, RXQ4, RXQ4/A, RXU, RXU/A, R1, R1/A	
2	21610-889-750	COVER, REDUCTION	1	1	1	RA, RA2, RA2/A, RD, RD/A, RH, RHE, RHE4, RHE4/A, RHQ4, RHQ4/A, RH26, RH26/A, RSC2, RSC2/A, RSS, RSS/A, RX, RX/A, RXP, RXP/A, RXQ4, RXQ4/A, RXU, RXU/A, R1, R1/A	
3	21691-889-750	PACKING, REDUCTION COVER	1	1	1	RA, RA2, RA2/A, RD, RD/A, RH, RHE, RHE4, RHE4/A, RHQ4, RHQ4/A, RH26, RH26/A, RSC2, RSC2/A, RSS, RSS/A, RX, RX/A, RXP, RXP/A, RXQ4, RXQ4/A, RXU, RXU/A, R1, R1/A	
4	22121-889-750	CENTER, CLUTCH	1	1	1	RA, RA2, RA2/A, RD, RD/A, RH, RHE, RHE4, RHE4/A, RHQ4, RHQ4/A, RH26, RH26/A, RSC2, RSC2/A, RSS, RSS/A, RX, RX/A, RXP, RXP/A, RXQ4, RXQ4/A, RXU, RXU/A, R1, R1/A	
5	22201-822-610	DISK, CLUTCH FRICTION	2	2	2	RA, RA2, RA2/A, RD, RD/A, RH, RHE, RHE4, RHE4/A, RHQ4, RHQ4/A, RH26, RH26/A, RSC2, RSC2/A, RSS, RSS/A, RX, RX/A, RXP, RXP/A, RXQ4, RXQ4/A, RXU, RXU/A, R1, R1/A	
6	22311-822-610	PLATE, CLUTCH	2	2	2	RA, RA2, RA2/A, RD, RD/A, RH, RHE, RHE4, RHE4/A, RHQ4, RHQ4/A, RH26, RH26/A, RSC2, RSC2/A, RSS, RSS/A, RX, RX/A, RXP, RXP/A, RXQ4, RXQ4/A, RXU, RXU/A, R1, R1/A	
7	22350-822-610	PLATE COMP., CLUTCH PRESSURE	1	1	1	RA, RA2, RA2/A, RD, RD/A, RH, RHE, RHE4, RHE4/A, RHQ4, RHQ4/A, RH26, RH26/A, RSC2, RSC2/A, RSS, RSS/A, RX, RX/A, RXP, RXP/A, RXQ4, RXQ4/A, RXU, RXU/A, R1, R1/A	
8	22411-822-611	SPRING, CLUTCH FREE	4	4	4	RA, RA2, RA2/A, RD, RD/A, RH, RHE, RHE4, RHE4/A, RHQ4, RHQ4/A, RH26, RH26/A, RSC2, RSC2/A, RSS, RSS/A, RX, RX/A, RXP, RXP/A, RXQ4, RXQ4/A, RXU, RXU/A, R1, R1/A	
9	22421-822-610	HOLDER, CLUTCH SPRING	4	4	4	RA, RA2, RA2/A, RD, RD/A, RH, RHE, RHE4, RHE4/A, RHQ4, RHQ4/A, RH26, RH26/A, RSC2, RSC2/A, RSS, RSS/A, RX, RX/A, RXP, RXP/A, RXQ4, RXQ4/A, RXU, RXU/A, R1, R1/A	



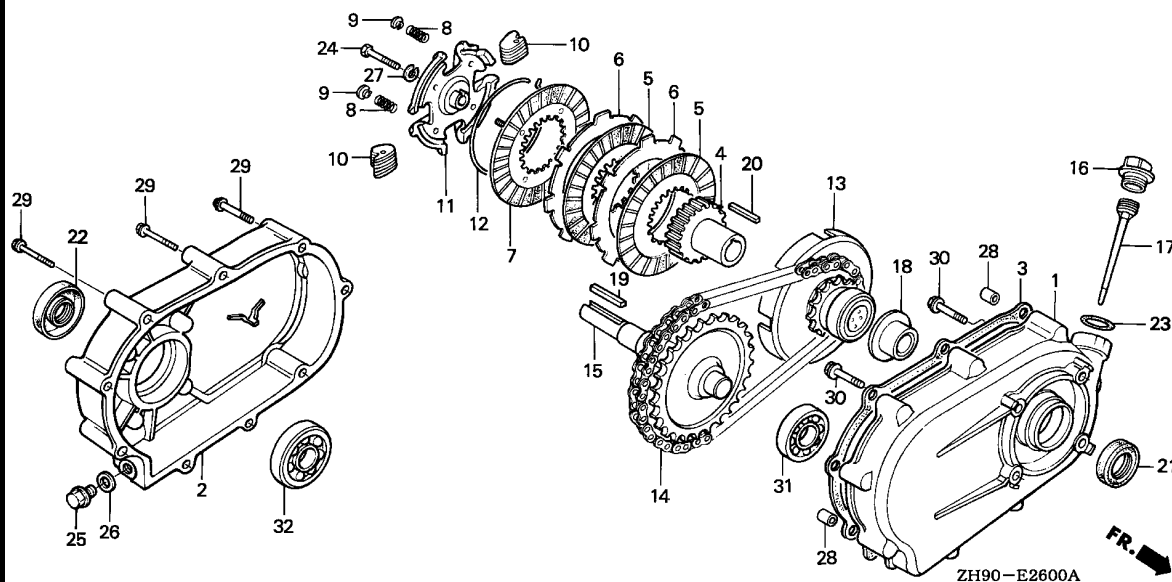

Ref. No.	Part No.	Description	Reqd. QTY			Serial No.	Parts catalogue code
			(1)	(2)	(3)		
10	22521-822-610	WEIGHT, CLUTCH	48	48	48	-----	RA, RA2, RA2/A, RD, RD/A, RH, RHE, RHE4, RHE4/A, RHQ4, RHQ4/A, RH26, RH26/A, RSC2, RSC2/A, RSS, RSS/A, RX, RX/A, RXP, RXP/A, RXQ4, RXQ4/A, RXU, RXU/A, R1 R1/A
11	22531-889-750	HOLDER, CLUTCH WEIGHT	1	1	1	-----	RA, RA2, RA2/A, RD, RD/A, RH, RHE, RHE4, RHE4/A, RHQ4, RHQ4/A, RH26, RH26/A, RSC2, RSC2/A, RSS, RSS/A, RX, RX/A, RXP, RXP/A, RXQ4, RXQ4/A, RXU, RXU/A, R1 R1/A
12	22535-822-610	CENTER, CLUTCH WEIGHT	1	1	1	-----	RA, RA2, RA2/A, RD, RD/A, RH, RHE, RHE4, RHE4/A, RHQ4, RHQ4/A, RH26, RH26/A, RSC2, RSC2/A, RSS, RSS/A, RX, RX/A, RXP, RXP/A, RXQ4, RXQ4/A, RXU, RXU/A, R1 R1/A
13	23120-889-750	SPROCKET COMP., DRIVE (14T) -	1	1	1	-----	RA, RA2, RA2/A, RD, RD/A, RH, RHE, RHE4, RHE4/A, RHQ4, RHQ4/A, RH26, RH26/A, RSC2, RSC2/A, RSS, RSS/A, RX, RX/A, RXP, RXP/A, RXQ4, RXQ4/A, RXU, RXU/A, R1 R1/A
14	23161-822-610	CHAIN, DRIVE	1	1	-	1034459	RA, RD, RH, RHE, RX, R1
	23161-822-611	CHAIN, DRIVE (RK428SH-36LE) -	1	1	1	-----	RA2, RA2/A, RD/A, RHE4, RHE4/A, RHQ4, RHQ4/A, RH26, RH26/A, RSC2, RSC2/A, RSS, RSS/A, RX/A, RXP, RXP/A, RXQ4, RXQ4/A, RXU, RXU/A, R1/A
15	23711-822-610	SHAFT COMP., P.T.O. (28T) ...	1	1	1	1034460	RA, RD, RH, RHE, RX, R1
			1	1	-	-----	RA, RA2, RA2/A, RD, RD/A, RH, RHE, RHE4, RHE4/A, RHQ4, RHQ4/A, RH26, RH26/A, RSC2, RSC2/A, RSS, RSS/A, RX, RX/A, RXP, RXP/A, RXQ4, RXQ4/A, RXU, RXU/A, R1 R1/A
16	25620-823-000	CAP, REDUCTION OIL (YELLOW) -	1	1	1	-----	RA, RA2, RA2/A, RD, RD/A, RH, RHE, RHE4, RHE4/A, RHQ4, RHQ4/A, RH26, RH26/A, RSC2, RSC2/A, RSS, RSS/A, RX, RX/A, RXP, RXP/A, RXQ4, RXQ4/A, RXU, RXU/A, R1 R1/A
	25620-805-612	CAP, REDUCTION OIL (GRAY) ...	1	1	1	-----	RA2/A, RD/A, RHE4/A, RHQ4/A, RH26/A, RSC2/A, RSS/A, RX/A, RXP/A, RXQ4/A, RXU/A, R1/A
17	25651-889-750	GAUGE, OIL LEVEL	1	1	1	-----	RA, RA2, RA2/A, RD, RD/A, RH, RHE, RHE4, RHE4/A, RHQ4, RHQ4/A, RH26, RH26/A, RSC2, RSC2/A, RSS, RSS/A, RX, RX/A, RXP, RXP/A, RXQ4, RXQ4/A, RXU, RXU/A, R1 R1/A

Ref. No.	Part No.	Description	Reqd. QTY			Serial No.	Parts catalogue code
			(1)	(2)	(3)		
18	90403-889-000	WASHER, THRUST, 25MM	1	1	1	-----	RA,RA2,RA2/A,RD,RD/A,RH,RHE,RHE4,RHE4/A,RHQ4,RHQ4/A,RH26,RH26/A RSC2,RSC2/A,RSS,RSS/A,RX,RX/A,RXP,RXP/A,RXQ4,RXQ4/A,RXU,RXU/A,R1 R1/A
19	90741-805-000	KEY, 7X7X33	1	1	1	-----	RA,RA2,RA2/A,RD,RD/A,RH,RHE,RHE4,RHE4/A,RHQ4,RHQ4/A,RH26,RH26/A RX,RX/A,RXP,RXP/A,RXQ4,RXQ4/A,RXU,RXU/A,R1,R1/A
	90741-889-810	KEY, 7X7X33(YELLOW)	(1)	(1)	(1)	-----	RA,RA2,RA2/A,RD,RD/A,RH,RHE,RHE4,RHE4/A,RHQ4,RHQ4/A,RH26,RH26/A RSC2,RSC2/A,RSS,RSS/A,RX,RX/A,RXP,RXP/A,RXQ4,RXQ4/A,RXU,RXU/A,R1 R1/A
20	90741-889-000	KEY, CLUTCH CENTER	1	1	1	-----	RA,RA2,RA2/A,RD,RD/A,RH,RHE,RHE4,RHE4/A,RHQ4,RHQ4/A,RH26,RH26/A RSC2,RSC2/A,RSS,RSS/A,RX,RX/A,RXP,RXP/A,RXQ4,RXQ4/A,RXU,RXU/A,R1 R1/A
21	91201-890-003	OIL SEAL, 30X46X8	1	1	1	-----	RA,RA2,RA2/A,RD,RD/A,RH,RHE,RHE4,RHE4/A,RHQ4,RHQ4/A,RH26,RH26/A RSC2,RSC2/A,RSS,RSS/A,RX,RX/A,RXP,RXP/A,RXQ4,RXQ4/A,RXU,RXU/A,R1 R1/A
22	91202-805-610	OIL SEAL (PJ30507)	1	1	1	-----	RA,RA2,RA2/A,RD,RD/A,RH,RHE,RHE4,RHE4/A,RHQ4,RHQ4/A,RH26,RH26/A RSC2,RSC2/A,RSS,RSS/A,RX,RX/A,RXP,RXP/A,RXQ4,RXQ4/A,RXU,RXU/A,R1 R1/A
23	91301-805-000	O-RING, 26X2.7	1	1	1	-----	RA,RA2,RA2/A,RD,RD/A,RH,RHE,RHE4,RHE4/A,RHQ4,RHQ4/A,RH26,RH26/A RSC2,RSC2/A,RSS,RSS/A,RX,RX/A,RXP,RXP/A,RXQ4,RXQ4/A,RXU,RXU/A,R1 R1/A
24	92100-08035-0H	BOLT, HEX., 8X35	1	1	-	-----	RA,RD,RH,RHE,RX,RXU,R1
	92101-08035-0H	1	-	1	-----	RA2,RHE4,RHQ4,RH26,RSC2,RSS,RXP,RXQ4
	92101-08035-0A	1	1	1	-----	RA2/A,RD/A,RHE4/A,RHQ4/A,RH26/A,RSC2/A,RSS/A,RX/A,RXP/A,RXQ4/A RXU/A,R1/A
25	92800-12000	BOLT, DRAIN PLUG, 12MM	1	1	1	-----	RA,RA2,RA2/A,RD,RD/A,RH,RHE,RHE4,RHE4/A,RHQ4,RHQ4/A,RH26,RH26/A RSC2,RSC2/A,RSS,RSS/A,RX,RX/A,RXP,RXP/A,RXQ4,RXQ4/A,RXU,RXU/A,R1 R1/A
26	94109-12000	WASHER, DRAIN PLUG, 12MM	1	1	1	-----	RA,RA2,RA2/A,RD,RD/A,RH,RHE,RHE4,RHE4/A,RHQ4,RHQ4/A,RH26,RH26/A RSC2,RSC2/A,RSS,RSS/A,RX,RX/A,RXP,RXP/A,RXQ4,RXQ4/A,RXU,RXU/A,R1 R1/A
27	94111-08800	WASHER, SPRING, 8MM	1	1	1	-----	RA,RA2,RA2/A,RD,RD/A,RH,RHE,RHE4,RHE4/A,RHQ4,RHQ4/A,RH26,RH26/A RSC2,RSC2/A,RSS,RSS/A,RX,RX/A,RXP,RXP/A,RXQ4,RXQ4/A,RXU,RXU/A,R1 R1/A
28	94301-08140	DOWEL PIN, 8X14	2	2	2	-----	RA,RA2,RA2/A,RD,RD/A,RH,RHE,RHE4,RHE4/A,RHQ4,RHQ4/A,RH26,RH26/A RSC2,RSC2/A,RSS,RSS/A,RX,RX/A,RXP,RXP/A,RXQ4,RXQ4/A,RXU,RXU/A,R1 R1/A
29	95700-06050-08	BOLT, FLANGE, 6X50	9	9	-	-----	RA,RD,RH,RHE,RX,RXU,R1
	95701-06050-08	9	9	9	-----	RA2,RA2/A,RD/A,RHE4,RHE4/A,RHQ4,RHQ4/A,RH26,RH26/A,RSC2,RSC2/A RSS,RSS/A,RX/A,RXP,RXP/A,RXQ4,RXQ4/A,RXU/A,R1/A
30	95700-08032-08	BOLT, FLANGE, 8X32	4	4	-	-----	RA,RD,RH,RHE,RX,RXU,R1
	95701-08032-08	4	4	4	-----	RA2,RA2/A,RD/A,RHE4,RHE4/A,RHQ4,RHQ4/A,RH26,RH26/A,RSC2,RSC2/A RSS,RSS/A,RX/A,RXP,RXP/A,RXQ4,RXQ4/A,RXU/A,R1/A
31	96100-62050-00	BEARING, RADIAL BALL, 6205 ..	1	1	1	-----	RA,RA2,RA2/A,RD,RD/A,RH,RHE,RHE4,RHE4/A,RHQ4,RHQ4/A,RH26,RH26/A RSC2,RSC2/A,RSS,RSS/A,RX,RX/A,RXP,RXP/A,RXQ4,RXQ4/A,RXU,RXU/A,R1 R1/A
32	96100-62060-00	BEARING, RADIAL BALL, 6206 ..	1	1	1	-----	RA,RA2,RA2/A,RD,RD/A,RH,RHE,RHE4,RHE4/A,RHQ4,RHQ4/A,RH26,RH26/A RSC2,RSC2/A,RSS,RSS/A,RX,RX/A,RXP,RXP/A,RXQ4,RXQ4/A,RXU,RXU/A,R1 R1/A



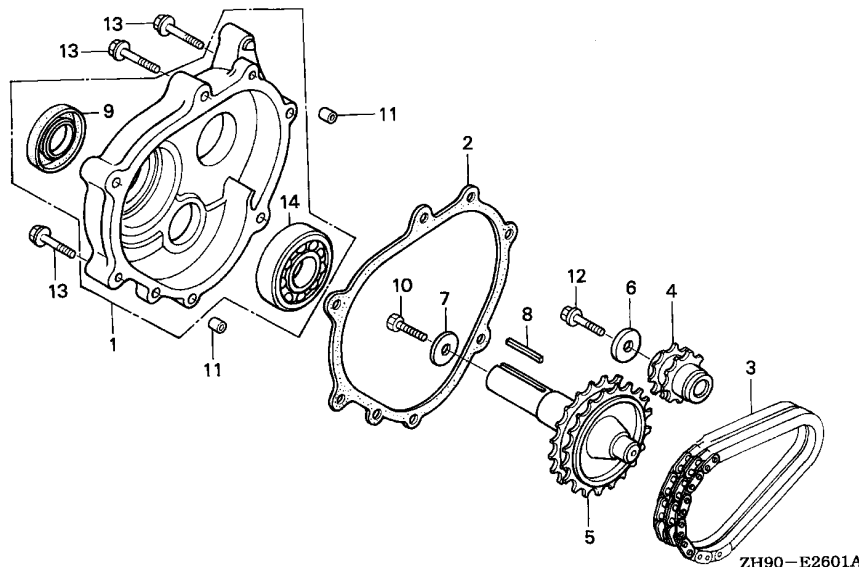

Ref. No.	L.O.N.	(Relative ref. Number) Description	F.R.T.
1	(2)	COVER, REDUCTION AND/OR PACKING, REDUCTION COVER (L-TYPE)	0.2
3	2141W2	CHAIN, POWER TAKE OFF DRIVE (L-TYPE)	0.2
4	2141X0	SPROCKET, POWER TAKE OFF DRIVE CHAIN(L-TYPE)	0.2
5	2141V7	SHAFT, POWER TAKE OFF(L-TYPE)	0.2
9	2141X3	OIL SEAL, POWER TAKE OFF SHAFT (L-TYPE) :REAR	0.3
14	2141X8	BEARING, POWER TAKE OFF SHAFT (L-TYPE) :REAR	0.4

Ref. No.	Part No.	Description	Reqd. QTY			Serial No.	Parts catalogue code
			(1)	(2)	(3)		
1	11500-ZE2-610	COVER ASSY., CHAIN CASE	1	1	-	LH,LH/A,LHB1,LHB3,LHB5,LHE,LHE/A,LHQ4,LJ,LJ/A,LJC,LJC/A,LJG,LJG/A,LSS,LTJ,LW,LW/A,LWD,LWD1,LWD1/A,LX,LX/A,LXE,LXE/A,LXE8,LXE8/A,LXQ4,LXQ4/A,LXU,LXU/A,LXZ,LX16,L1,L1/A	
	11500-ZK2-800	1	-	-	LT,LT/A	
2	11521-ZE2-610	PACKING, CHAIN CASE COVER ...	1	(1)	-	1047495 LJ,LW,LXZ,L1	
	11521-ZE2-800	1	(1)	-	LH,LH/A,LHB1,LHB3,LHB5,LHE,LHE/A,LHQ4,LJ/A,LJC,LJC/A,LJG,LJG/A,LSS,LT,LT/A,LTJ,LW/A,LWD,LWD1,LWD1/A,LX,LX/A,LXE,LXE/A,LXE8,LXE8/A,LXQ4,LXQ4/A,LXU,LXU/A,LX16,L1/A	
3	14411-ZE2-611	CHAIN, P.T.O. DRIVE	1	(1)	-	1047496 LJ,LW,LXZ,L1	
		1	1	-	LH,LH/A,LHB1,LHB3,LHB5,LHE,LHE/A,LHQ4,LJ,LJ/A,LJC,LJC/A,LJG,LJG/A,LSS,LT,LT/A,LTJ,LW/A,LWD,LWD1,LWD1/A,LX,LX/A,LXE,LXE/A,LXE8,LXE8/A,LXQ4,LXQ4/A,LXU,LXU/A,LXZ,LX16,L1,L1/A	
4	23110-ZE2-610	SPROCKET, DRIVE (14T)	1	1	-	LH,LH/A,LHB1,LHB3,LHB5,LHE,LHE/A,LHQ4,LJ,LJ/A,LJC,LJC/A,LJG,LJG/A,LSS,LT,LT/A,LTJ,LW/A,LWD,LWD1,LWD1/A,LX,LX/A,LXE,LXE/A,LXE8,LXE8/A,LXQ4,LXQ4/A,LXU,LXU/A,LXZ,LX16,L1,L1/A	
5	23710-ZE2-610	SHAFT, P.T.O. (28T)	1	1	-	LH,LH/A,LHB1,LHB3,LHB5,LHE,LHE/A,LHQ4,LJ,LJ/A,LJC,LJC/A,LJG,LJG/A,LSS,LTJ,LW,LW/A,LWD,LWD1,LWD1/A,LX,LX/A,LXE,LXE/A,LXE8,LXE8/A,LXQ4,LXQ4/A,LXU,LXU/A,LXZ,LX16,L1,L1/A	
	23710-ZK2-800	1	-	-	LT,LT/A	
6	90473-842-000	WASHER, 8MM	1	1	-	LH,LH/A,LHB1,LHB3,LHB5,LHE,LHE/A,LHQ4,LJ,LJ/A,LJC,LJC/A,LJG,LJG/A,LSS,LT,LT/A,LTJ,LW,LW/A,LWD,LWD1,LWD1/A,LX,LX/A,LXE,LXE/A,LXE8,LXE8/A,LXQ4,LXQ4/A,LXU,LXU/A,LXZ,LX16,L1,L1/A	
7	90471-ZE3-000	WASHER, 10.5X40X4	1	-	-	LT,LT/A	
	90534-706-010	WASHER, LOCK, 8MM	1	(1)	-	LJ,LJ/A,LJC,LJC/A,LJG,LJG/A,LSS,LTJ,LWD1,LWD1/A,L1,L1/A	
8	90741-805-000	KEY, 7X7X33	1	(1)	-	LH,LH/A,LHB1,LHB3,LHB5,LHE,LHE/A,LHQ4,LJ,LJ/A,LJC,LJC/A,LJG,LJG/A,LSS,LTJ,LW,LW/A,LWD,LWD1,LWD1/A,LX,LX/A,LXE,LXE/A,LXE8,LXE8/A,LXQ4,LXQ4/A,LXU,LXU/A,LXZ,LX16,L1,L1/A	

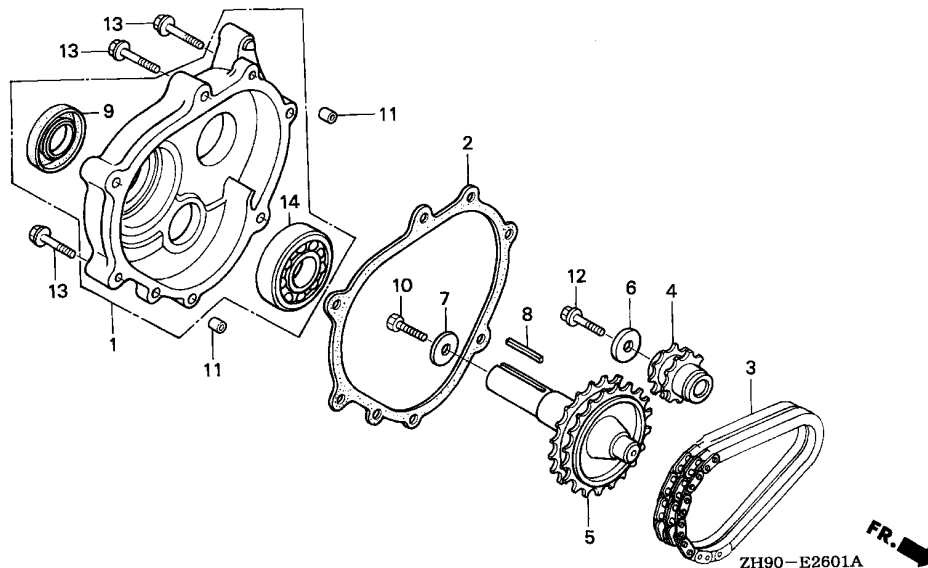

Ref. No.	Part No.	Description	Reqd. QTY			Serial No.	Parts catalogue code
			(1)	(2)	(3)		
(8)	90741-889-810	KEY, 7X7X33 (YELLOW)	(1)	(1)	-	LH,LH/A,LHB1,LHB3,LHB5,LHE,LHE/A,LHQ4,LJ,LJ/A,LJC,LJC/A,LJG,LJG/A,LSS,LTJ,LW,LW/A,LWD,LWD1,LWD1/A,LX,LX/A,LXE,LXE/A,LXE8,LXE8/A,LXQ4,LXQ4/A,LXU,LXU/A,LXZ,LX16,L1,L1/A	
	90745-ZK2-800	KEY, 6.3X6.3X33	1	-	-	LT,LT/A	
9	91201-890-003	OIL SEAL, 30X46X8	1	(1)	-	LH,LH/A,LHB1,LHB3,LHB5,LHE,LHE/A,LHQ4,LJ,LJ/A,LJC,LJC/A,LJG,LJG/A,LSS,LT,LT/A,LTJ,LW,LW/A,LWD,LWD1,LWD1/A,LX,LX/A,LXE,LXE/A,LXE8,LXE8/A,LXQ4,LXQ4/A,LXU,LXU/A,LXZ,LX16,L1,L1/A	
10	92000-08025-0A	BOLT, HEX., 8X25	1	(1)	-	LJ,L1,L1/A	
	92101-08025-0A	1	-	-	LJ/A,LJC,LJC/A,LJG,LJG/A,LSS,LTJ,LWD1,LWD1/A	
	95701-08025-00	BOLT, FLANGE, 8X25	1	-	-	LWD	
11	94301-08140	DOWEL PIN, 8X14	2	2	-	LH,LH/A,LHB1,LHB3,LHB5,LHE,LHE/A,LHQ4,LJ,LJ/A,LJC,LJC/A,LJG,LJG/A,LSS,LT,LT/A,LTJ,LW,LW/A,LWD,LWD1,LWD1/A,LX,LX/A,LXE,LXE/A,LXE8,LXE8/A,LXQ4,LXQ4/A,LXU,LXU/A,LXZ,LX16,L1,L1/A	
12	95701-08025-00	BOLT, FLANGE, 8X25	1	1	-	LH/A,LHB1,LHB3,LHB5,LHE/A,LHQ4,LJ/A,LJC,LJC/A,LJG,LJG/A,LSS,LT,LT/A,LTJ,LW/A,LWD,LWD1,LWD1/A,LX/A,LXE,LXE/A,LXE8,LXE8/A,LXQ4,LXQ4/A,LXU/A,LX16,L1/A	
	95900-08025-00	1	1	-	LH,LHE,LJ,LW,LX,LXU,LXZ,L1	
13	95701-08040-00	BOLT, FLANGE, 8X40	6	6	-	LH/A,LHB1,LHB3,LHB5,LHE/A,LHQ4,LJ/A,LJC,LJC/A,LJG,LJG/A,LSS,LT,LT/A,LTJ,LW/A,LWD,LWD1,LWD1/A,LX/A,LXE,LXE/A,LXE8,LXE8/A,LXQ4,LXQ4/A,LXU/A,LX16,L1/A	
	95900-08040-00	6	6	-	LH,LHE,LJ,LW,LX,LXU,LXZ,L1	
14	96100-62060-00	BEARING, RADIAL BALL, 6206	1	1	-	LH,LH/A,LHB1,LHB3,LHB5,LHE,LHE/A,LHQ4,LJ,LJ/A,LJC,LJC/A,LJG,LJG/A,LSS,LT,LT/A,LTJ,LW,LW/A,LWD,LWD1,LWD1/A,LX,LX/A,LXE,LXE/A,LXE8,LXE8/A,LXQ4,LXQ4/A,LXU,LXU/A,LXZ,LX16,L1,L1/A	

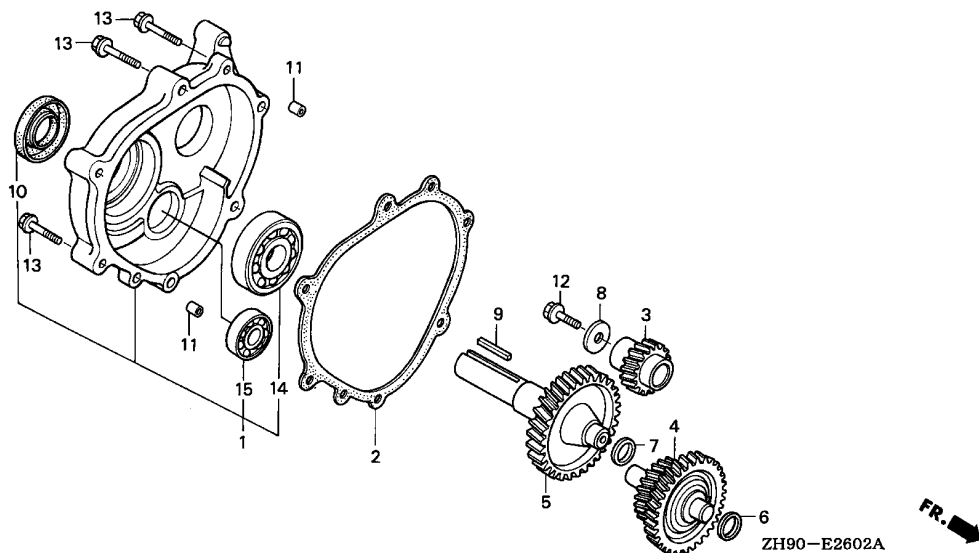

Ref. No.	L.O.N.	(Relative ref. Number) Description	F.R.T.
1	(2)		
2141W8		COVER, REDUCTION AND/OR PACKING, REDUCTION COVER (H-TYPE)	0.2
3	2141L2	GEAR, PRIMARY DRIVE	0.2
4	2141Z9	COUNTERSHAFT, REDUCTION (H-TYPE)	0.2
5	2141V9	SHAFT, POWER TAKE OFF(H-TYPE)	0.2
10	2141X5	OIL SEAL, POWER TAKE OFF SHAFT (H-TYPE) :REAR	0.3
14	2141Y0	BEARING, POWER TAKE OFF SHAFT (H-TYPE) :REAR	0.4
15	2101U4	BEARING, COUNTERSHAFT :REAR ..	0.4

Ref. No.	Part No.	Description	Reqd. QTY			Serial No.	Parts catalogue code
			(1)	(2)	(3)		
1	11500-ZE2-620	COVER ASSY., REDUCTION CASE	1	-	1	-----	HA,HAP,HAP/A,HAQ,HA2,HA2/A,HEA,HEA2,HEA2/A,HEA8,HEA8/A,HH,HX,HX/A HXQ4,HXQ4/A,HX26,HX26/A,HX8,HX8/A
2	11521-ZE2-800	PACKING, CHAIN CASE COVER	1	-	1	-----	HA,HAP,HAP/A,HAQ,HA2,HA2/A,HEA,HEA2,HEA2/A,HEA8,HEA8/A,HH,HX,HX/A HXQ4,HXQ4/A,HX26,HX26/A,HX8,HX8/A
3	22103-ZE2-620	GEAR, PRIMARY DRIVE (17T)	1	-	1	-----	HA,HAP,HAP/A,HAQ,HA2,HA2/A,HEA,HEA2,HEA2/A,HEA8,HEA8/A,HH,HX,HX/A HXQ4,HXQ4/A,HX26,HX26/A,HX8,HX8/A
4	23220-ZE2-621	COUNTERSHAFT COMP.	1	-	1	-----	HA,HAP,HAP/A,HAQ,HA2,HA2/A,HEA,HEA2,HEA2/A,HEA8,HEA8/A,HH,HX,HX/A HXQ4,HXQ4/A,HX26,HX26/A,HX8,HX8/A
5	23710-ZE2-621	SHAFT, P.T.O. (46T)	1	-	1	-----	HA,HAP,HAP/A,HAQ,HA2,HA2/A,HEA,HEA2,HEA2/A,HEA8,HEA8/A,HH,HX,HX/A HXQ4,HXQ4/A,HX26,HX26/A,HX8,HX8/A
6	90401-ZE2-620	SHIM A	N	-	N	-----	HA,HAP,HAP/A,HAQ,HA2,HA2/A,HEA,HEA2,HEA2/A,HEA8,HEA8/A,HH,HX,HX/A HXQ4,HXQ4/A,HX26,HX26/A,HX8,HX8/A
7	90402-ZE2-620	SHIM B	N	-	N	-----	HA,HAP,HAP/A,HAQ,HA2,HA2/A,HEA,HEA2,HEA2/A,HEA8,HEA8/A,HH,HX,HX/A HXQ4,HXQ4/A,HX26,HX26/A,HX8,HX8/A
8	90473-842-000	WASHER, 8MM	1	-	1	-----	HA,HAP,HAP/A,HAQ,HA2,HA2/A,HEA,HEA2,HEA2/A,HEA8,HEA8/A,HH,HX,HX/A HXQ4,HXQ4/A,HX26,HX26/A,HX8,HX8/A
	90745-ZE2-600	KEY, 6.3X6.3X63	-	-	1	-----	HAP
	90745-ZE2-600	KEY, 6.3X6.3X43	1	-	1	-----	HA,HAP/A,HAQ,HA2,HA2/A,HEA,HEA2,HEA2/A,HEA8,HEA8/A,HH,HX,HX/A HXQ4,HXQ4/A,HX26,HX26/A,HX8,HX8/A
10	91201-890-003	OIL SEAL, 30X46X8	1	-	1	-----	HA,HAP,HAP/A,HAQ,HA2,HA2/A,HEA,HEA2,HEA2/A,HEA8,HEA8/A,HH,HX,HX/A HXQ4,HXQ4/A,HX26,HX26/A,HX8,HX8/A
11	94301-08140	DOWEL PIN, 8X14	2	-	2	-----	HA,HAP,HAP/A,HAQ,HA2,HA2/A,HEA,HEA2,HEA2/A,HEA8,HEA8/A,HH,HX,HX/A HXQ4,HXQ4/A,HX26,HX26/A,HX8,HX8/A
12	95701-08025-00	BOLT, FLANGE, 8X25	1	-	1	-----	HAP,HAP/A,HAQ,HA2,HA2/A,HEA,HEA2,HEA2/A,HEA8,HEA8/A,HX/A,HXQ4 HXQ4/A,HX26,HX26/A,HX8/A
	95900-08025-00		1	-	-	-----	HA,HH,HX,HX8

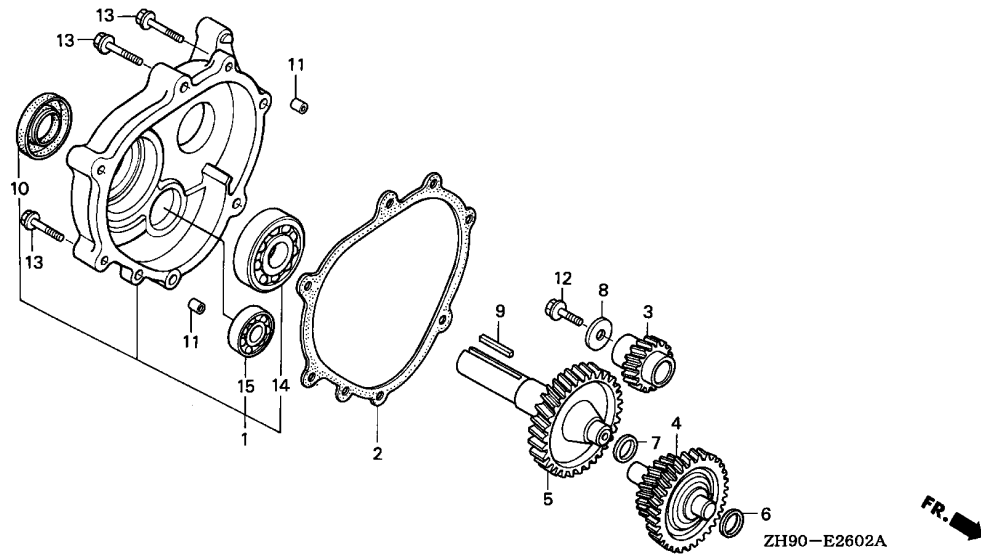

Ref. No.	Part No.	Description	Reqd. QTY			Serial No.	Parts catalogue code
			(1)	(2)	(3)		
13	95701-08040-00	BOLT, FLANGE, 8X40	6	-	6	-----	HAP,HAP/A,HAQ,HA2,HA2/A,HEA,HEA2,HEA2/A,HEA8,HEA8/A,HX/A,HXQ4 HXQ4/A,HX26,HX26/A,HX8/A
	95900-08040-00	6	-	-	-----	HA,HH,HX,HX8
14	96100-62060-00	BEARING, RADIAL BALL, 6206 ..	1	-	1	-----	HA,HAP,HAP/A,HAQ,HA2,HA2/A,HEA,HEA2,HEA2/A,HEA8,HEA8/A,HH,HX,HX/A HXQ4,HXQ4/A,HX26,HX26/A,HX8,HX8/A
15	96100-63020-00	BEARING, RADIAL BALL, 6302 ..	1	-	1	-----	HA,HAP,HAP/A,HAQ,HA2,HA2/A,HEA,HEA2,HEA2/A,HEA8,HEA8/A,HH,HX,HX/A HXQ4,HXQ4/A,HX26,HX26/A,HX8,HX8/A



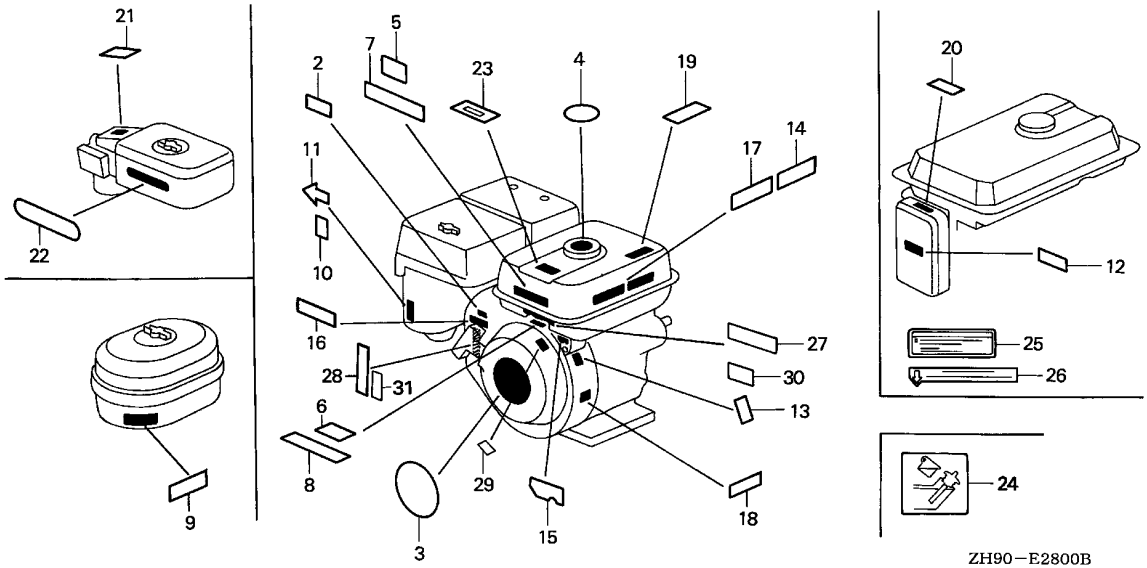

ZH90-E2800B

Ref. L.O.N. (Relative ref. Number) F.R.T.
No. Description

NO INFORMATION

Ref. No.	Part No.	Description	Reqd. QTY			Serial No.	Parts catalogue code
			(1)	(2)	(3)		
2	87124-ZV3-010	MARK, EMERGENCY SWITCH INDICATION	-	-	1		
3	87521-ZH9-810	EMBLEM (EXTERNAL)	1	(1)	-	1033679	HA,HH,HX,LH,LHE,LW,LX,LXZ,L1,PA,PX,QA,QAE,QD,QE,QH,QHC,QHE,QP,QX,QXB,QXC,QXE,QXEB,Q1,RA,RD,RH,RHE,RX,R1,SD,SE,SH,SHE,SHEZ,SW,SWE,SX,SXB,SXE,SXEB,VA,VAW,VH,VNG1,VSD,VX,VXB,VXE,VXEB,V1,W1
	87521-ZH9-010	EMBLEM	1	(1)	1		HAP,HAQ,HEA,LHB1,LHB3,LHQ4,LX16,QAB1,QAQ,QL2,QSC,QWA2,Q1/A,RXP,SKE1,SMD,SX2,VAW1,VDE,VD16,VEB6,VWA,VW22,VXB2,VXB6,VXG,VXP,VXQP,VXTB,VX26,W1/A
			1	(1)	-	1033680	HA,HH,LXZ,PA,QA,QAE,QHC,QHE,QXC,QXEB,Q1,Q2,RA,RH,RHE,SHE,SHEZ,SW,SWE,VA,VAW,VH,VXE,V1,W1
			1	(1)	-	1033680	1812277 HX,LH,LHE,LW,LX,L1,PX,QD,QE,QH,QP,QX,QXB,QXE,RD,RX,R1,SD,SE,SH,SX,SXB,SXE,SXEB,VNG1,VSD,VX,VXB,VXEB
			1	-	-	1812277	ES1,ES3,HA2,HEA2,HEA8,HXQ4,HX26,HX8,LT,LXE,LXE8,LXQ4,LXU,PAE2,PA2,PXE8,PXU,PX26,QAB3,QAE2,QAE6,QAG,QAG2,QAQ4,QAR2,QAW,QA2,QHE4,QHP1,QHQ4,QHR,QHR4,QHZ,QH26,QME2,QMH,QSC9,QSE,QSE8,QT,QWA4,QWH2,QXB6,QXC4,QXC6,QXC9,QXE4,QXE6,QXE8,QXQ4,QXU,QX26,RA2,RHE4,RHQ4,RH26,RSC2,RXQ4,RXU,SHQ4,SMC4,SME1,SME6,SN,SWC4,SXE4,SXE8, SXQ4, SXU,VA2,VDE2,VKB2,VME2,VMT,VM2,VNT2,VN17,VPE4,VPE7,VPX4,VSD3,VWA2,VWN2,VWT4,VW12,VXE4,VXE6,VXQ4,VXT1,VXU,VXU1,WMT8,WXE8

Ref. No.	Part No.	Description	Reqd. QTY			Serial No.	Parts catalogue code	
			(1)	GX270 (2)	(3)			
(3)	87521-ZH9-020	EMBLEM	1	(1)	-	-----	LHQ4, LX16, L1/A, QKE3, QKE3/A, QKE4, QWA2, QXB7, R1/A, SXB7, VAG2, VD16 VEB6, VPX7, VSD7, VS37, VXB6, VXB7, VXE7, VX26	
			1	(1)	-	1812278	-----	ES1, ES3, HA2, HEA2, HEA8, HX, HXQ4, HX26, HX8, LH, LHE, LT, LW, LX, LXE, LXE8 LXQ4, LXU, L1, PAE2, PA2, PX, PXE8, PXU, PX26, QAB3, QAE2, QAE6, QAG, QAG2 QAQ4, QAR2, QAW, QA2, QD, QE, QH, QHE4, QHP1, QHQ4, QHR, QHR4, QHZ, QH26, QME2 QMH, QP, QSC9, QSE, QSE8, QT, QWA4, QWH2, QX, QXB, QXB6, QXC4, QXC6, QXC9, QXE QXE4, QXE6, QXE8, QXQ4, QXU, QX26, RA2, RD, RHE4, RHQ4, RH26, RSC2, RX, RXQ4 RXU, R1, SD, SE, SH, SHQ4, SMC4, SME1, SME6, SN, SWC4, SX, SXB, SXE, SXEB, SXE4 SXE8, SXQ4, SXU, VA2, VDE2, VKB2, VME2, VMT, VM2, VNG1, VNT2, VN17, VPE4, VPE7 VPX4, VSD, VSD3, VWA2, VWN2, VWT4, VW12, VX, VXB, VXEB, VXE4, VXE6, VXQ4, VXT1 VXU, VXU1, WMT8, WXE8
			1	-	-	2082940	-----	ES1/A, ES3/A, HA2/A, HEA2/A, HEA8/A, HX/A, HXQ4/A, HX26/A, HX8/A, LH/A LHB5, LHE/A, LT/A, LW/A, LX/A, LXE/A, LXE8/A, LXQ4/A, LXU/A, PAE2/A, PA2/A PX/A, PXE8/A, PXU/A, PX26/A, QAB3/A, QAE2/A, QAE6/A, QAG/A, QAG2/A, QAQ4/A QAR2/A, QAW/A, QA2/A, QD/A, QE/A, QH/A, QHB5, QHE4/A, QHP1/A, QHQ4/A, QHR/A QHR4/A, QHZ/A, QH26/A, QME2/A, QMH/A, QP/A, QSC9/A, QSE/A, QSE2, QSE8/A QT/A, QWA4/A, QWH2/A, QX/A, QXB/A, QXB6/A, QXB7/A, QXC4/A, QXC6/A, QXC9/A QXE/A, QXE4/A, QXE6/A, QXE8/A, QXQ4/A, QXU/A, QX26/A, RA2/A, RD/A, RHE4/A RHQ4/A, RH26/A, RSC2/A, RX/A, RXQ4/A, RXU/A, SD/A, SE/A, SH/A, SHQ4/A SMC4/A, SME1/A, SME6/A, SN/A, SWC4/A, SX/A, SXB/A, SXB7/A, SXE/A, SXEB/A SXE4/A, SXE8/A, SXQ4/A, SXU/A, VAG2/A, VA2/A, VDE2/A, VKB2/A, VME2/A VMT/A, VM2/A, VNG1/A, VNT2/A, VN17/A, VPE4/A, VPE7/A, VPX4/A, VPX7/A VSD/A, VSD3/A, VSD7/A, VS37/A, VWA2/A, VWN2/A, VWT4/A, VW12/A, VX/A, VXB/A VXB7/A, VXEB/A, VXE4/A, VXE6/A, VXE7/A, VXQ4/A, VXT1/A, VXU/A, VXU1/A WMT8/A, WXE8/A
-	-	1	-----	1100008	-----	HAP/A, RXP/A, VXP/A		
	87521-ZH9-030	1	-	-	-----	SMX2, SWA4, VKE4, VKX4, VMA4, VME4, VMS2, VMX2, VPE5, VPX5, VSH7, VS3, WMA4	
			1	-	-	2082941	-----	ES1/A, ES3/A, HA2/A, HEA2/A, HEA8/A, HX/A, HXQ4/A, HX26/A, HX8/A, LH/A LHB5, LHE/A, LT/A, LW/A, LX/A, LXE/A, LXE8/A, LXQ4/A, LXU/A, PAE2/A, PA2/A PX/A, PXE8/A, PXU/A, PX26/A, QAB3/A, QAE2/A, QAE6/A, QAG/A, QAG2/A, QAQ4/A QAR2/A, QAW/A, QA2/A, QD/A, QE/A, QH/A, QHB5, QHE4/A, QHP1/A, QHQ4/A, QHR/A QHR4/A, QHZ/A, QH26/A, QME2/A, QMH/A, QP/A, QSC9/A, QSE/A, QSE2, QSE8/A QT/A, QWA4/A, QWH2/A, QX/A, QXB/A, QXB6/A, QXB7/A, QXC4/A, QXC6/A, QXC9/A QXE/A, QXE4/A, QXE6/A, QXE8/A, QXQ4/A, QXU/A, QX26/A, RA2/A, RD/A, RHE4/A RHQ4/A, RH26/A, RSC2/A, RX/A, RXQ4/A, RXU/A, SD/A, SE/A, SH/A, SHQ4/A SMC4/A, SME1/A, SME6/A, SN/A, SWC4/A, SX/A, SXB/A, SXB7/A, SXE/A, SXEB/A SXE4/A, SXE8/A, SXQ4/A, SXU/A, VAG2/A, VA2/A, VDE2/A, VKB2/A, VME2/A VMT/A, VM2/A, VNG1/A, VNT2/A, VN17/A, VPE4/A, VPE7/A, VPX4/A, VPX7/A VSD/A, VSD3/A, VSD7/A, VS37/A, VWA2/A, VWN2/A, VWT4/A, VW12/A, VX/A, VXB/A VXB7/A, VXEB/A, VXE4/A, VXE6/A, VXE7/A, VXQ4/A, VXT1/A, VXU/A, VXU1/A WMT8/A, WXE8/A
4	87522-ZE1-810	MARK, CAUTION	-	-	1	1100009	-----	HAP/A, RXP/A, VXP/A
			1	(1)	-	1090815	-----	HA, HAQ, HA2, HEA, HH, HX, LH, LHE, LW, LX, LXZ, L1, PA, PA2, PX, QA, QAE, QAE2 QAQ, QA2, QD, QE, QH, QHC, QHE, QP, QSC, QX, QXB, QXC, QXE, QXEB, Q1, Q2, RA, RA2 RD, RH, RHE, RX, R1, SD, SE, SH, SHE, SHEZ, SN, SW, SWE, SX, SXB, SXE, SXEB, VA VA2, VH, VSD, VX, VXB, VXE, VXEB, VXU, V1, W1
5	87522-ZH8-W40	MARK, CAUTION (PICTOGRAPH) ..	1	-	-	-----	LHB1, LHB3, LT, LT/A, QAB1, QAB3, QAB3/A, QT, QT/A, VXG	
			1	-	-	1056014	-----	VSD3
			1	-	-	-----	HXQ4, LHQ4, LXQ4, QAQ4, QHE4, QHQ4, QHR, QHR4, QME2, QWA4, QXB7, QXC4, QXE4 QXQ4, RHE4, RHQ4, RXQ4, SHQ4, SMC4, SME1, SME6, SWC4, SXB7, SXE4, SXQ4, VD16 VEB6, VSD7, VXB7, VXE4, VXE7, VXQ4, VXTB	
			1	-	-	1110061	-----	QE, QXB, SE, SXB, SXEB, VSD, VXB, VXEB, VXG
			1	-	-	2155985	-----	HXQ4/A, LXQ4/A, QAQ4/A, QE/A, QHE4/A, QHQ4/A, QHR/A, QHR4/A, QKE4, QME2/A QWA4/A, QXB/A, QXB7/A, QXC4/A, QXE4/A, QXQ4/A, RHE4/A, RHQ4/A, RXQ4/A SE/A, SHQ4/A, SMC4/A, SME1/A, SME6/A, SWC4/A, SXB/A, SXB7/A, SXEB/A SXE4/A, SXQ4/A, VSD/A, VSD7/A, VSH7, VXB/A, VXB7/A, VXEB/A, VXE4/A, VXE7/A VXQ4/A



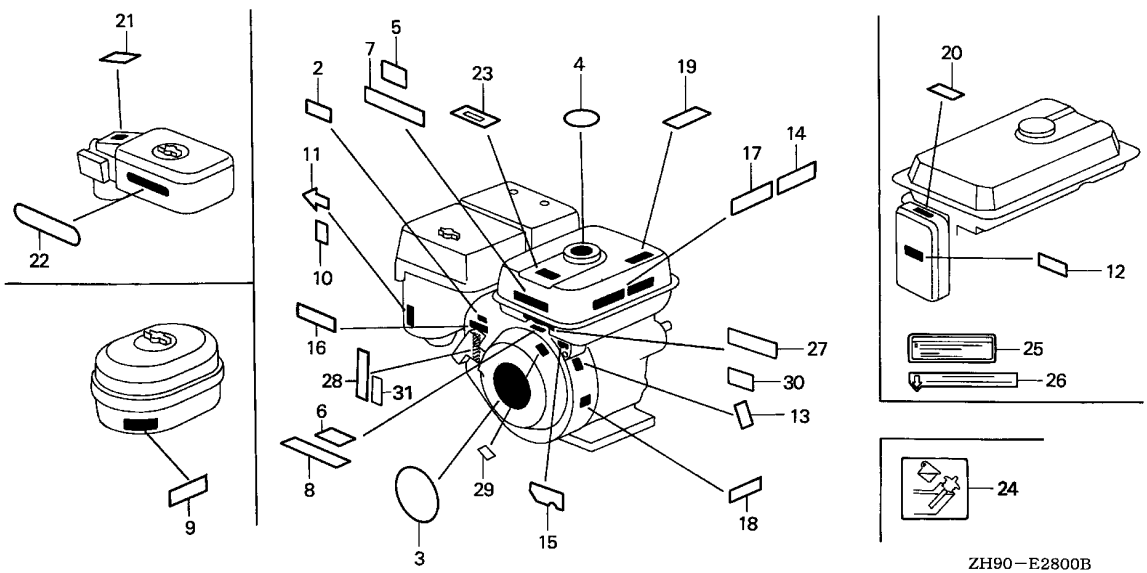

ZH90-E2800B

Ref. No.	Part No.	Description	Reqd. QTY			Serial No.	Parts catalogue code
			(1)	(2)	(3)		
(5)	87522-ZH8-W41	MARK, CAUTION (PICTOGRAPH) ..	1	-	-	-----	SWA4,WMA4
			1	-	-	2155986	HXQ4/A,LXQ4/A,QAQ4/A,QE/A,QHE4/A,QHQ4/A,QHR/A,QHR4/A,QKE4,QME2/A QWA4/A,QXB/A,QXB7/A,QXC4/A,QXE4/A,QXQ4/A,RHE4/A,RHQ4/A,RXQ4/A SE/A,SHQ4/A,SMC4/A,SME1/A,SME6/A,SWC4/A,SXB/A,SXB7/A,SXEB/A SXE4/A,SXQ4/A,VSD/A,VSD7/A,VSH7,VXB/A,VXB7/A,VXEB/A,VXE4/A,VXE7/A VXQ4/A
6	87522-ZH8-W40	MARK, CAUTION (PICTOGRAPH) ..	1	-	1	-----	QKE3,VXQP
	87522-ZH8-W41	1	-	-	2155985	QKE3/A
	87522-ZH8-W41	1	-	-	-----	SWA4
	87522-ZH8-W41	1	-	-	2155986	QKE3/A
7	87522-ZH9-000	LABEL, CAUTION (ENGLISH, ETC.)	1	(1)	-	-----	HA,HAQ,HEA,HH,LHB1,LHB3,LXZ,LX16,L1,L1/A,PA,QA,QAB1,QAE,QAQ,QHC QHE,QL2,QSC,QWA2,QXC,QXEB,Q1,Q1/A,Q2,RA,RH,RHE,R1,R1/A,SHE,SHEZ SKE1,SMD,SW,SWE,SX2,VA,VD16,VEB6,VH,VW22,VXB2,VXB6,VXE,VX26,V1,W1 W1/A
			1	-	-	1056014	VSD3
			1	-	-	1110060	QE,QXB,SE,SXB,SXEB,VSD,VXB,VXEB,VXG
	87522-ZH9-820	LABEL, CAUTION (THAI)	1	-	-	-----	LT,QT
			1	-	-	2204588	LT/A,QT/A

Ref. No.	Part No.	Description	Reqd. QTY			Serial No.	Parts catalogue code
			(1)	(2)	(3)		
(7)	87522-ZH9-010	LABEL, CAUTION (ENGLISH, ETC.)	1	-	1	-----	ES1,ES1/A,HAP,HAP/A,HA2,HA2/A,HEA2,HEA2/A,HEA8,HEA8/A,HX,HX/A,HX26,HX26/A,HX8,HX8/A,LH,LH/A,LHB5,LHE,LHE/A,LW,LW/A,LX,LX/A,LXE,LXE/A,LXE8,LXE8/A,LXU,LXU/A,PAE2,PAE2/A,PA2,PA2/A,PX,PX/A,PXE8,PXE8/A,PXU,PXU/A,PX26,PX26/A,QAB3,QAB3/A,QAE2,QAE2/A,QAE6,QAE6/A,QAG,QAG/A,QAG2,QAG2/A,QAR2,QAR2/A,QAW,QA2,QD,QD/A,QH,QH/A,QHB5,QHP1,QHP1/A,QHZ,QHZ/A,QH26,QH26/A,QKE4,QMH,QMH/A,QP,QP/A,QSC9,QSC9/A,QSE,QSE/A,QSE2,QSE8,QSE8/A,QWA4,QWA4/A,QWH2/A,QX,QX/A,QXB6,QXB6/A,QXC6,QXC6/A,QXC9,QXE,QXE/A,QXE6,QXE6/A,QXE8,QXE8/A,QXU,QXU/A,QX26,QX26/A,RA2,RA2/A,RD,RD/A,RH26,RH26/A,RX,RX/A,RXU,RXU/A,SD,SD/A,SH,SH/A,SMX2,SN,SN/A,SWC4,SWC4/A,SX,SX/A,SXE,SXE/A,SXE8,SXE8/A,SXU,SXU/A,VA2,VA2/A,VKB2,VKB2/A,VME2,VME2/A,VMS2,VMX2,VM2,VM2/A,VX,VX/A,VXE6,VXE6/A,VXU,VXU/A,VXU1,VXU1/A,WMT8,WMT8/A,WXE8,WXE8/A
	87522-ZH9-821	LABEL, CAUTION (THAI)	1	-	-	2375749	QAW/A,QA2/A,QXC9/A
8	87522-ZH9-000	LABEL, CAUTION (ENGLISH, ETC.)	-	-	1	2204589	LT/A,QT/A
	87522-ZH9-010	1	-	1	-----	VXQP
9	87524-883-690	MARK, AIR CLEANER CAUTION (COIL BATH) (ARABIC)	1	-	-	-----	RXP,RXP/A,VMS2,VMX2,VXP,VXP/A,VXT1,VXT1/A
10	87528-ZE1-690	MARK, CHOKE (THAI)	1	-	-	-----	LT,LT/A,LW,LW/A,QP,QP/A,QT,QT/A,SW,SWE
	87528-ZF6-W40	MARK, CHOKE (BLACK)	1	-	-	-----	LT,LT/A,QT,QT/A
			1	-	-	-----	HXQ4/A,LXQ4/A,QAQ4/A,QE/A,QHE4/A,QHQ4/A,QHR,QHR/A,QHR4,QHR4/A,QKE3,QKE3/A,QKE4,QME2/A,QWA4,QWA4/A,QXB/A,QXB7/A,QXC4,QXC4/A,QXE4/A,QXQ4/A,RHE4/A,RHQ4/A,RXQ4/A,SE/A,SHQ4/A,SMC4/A,SME1/A,SME6/A,SWA4,SWC4,SWC4/A,SXB/A,SXB7,SXB7/A,SXEB/A,SXE4/A,SXQ4/A,VD16,VEB6,VMA4,VME4,VNG1/A,VN17,VN17/A,VSD/A,VSD7,VSD7/A,VS7,VXB/A,VXB7,VXB7/A,VXEB/A,VXE4/A,VXE7,VXE7/A,VXQ4/A,VXTB,WMA4
	87528-ZE2-810	MARK, CHOKE (ORANGE)	1	-	-	1110061	QE,QXB,SE,SXB,SXEB,VNG1,VSD,VXB,VXEB,VXG
			1	(1)	-	-----	ES1,ES1/A,HA,HAQ,HA2,HA2/A,HEA,HEA2,HEA2/A,HEA8,HEA8/A,HH,HX,HX/A,HX26,HX26/A,HX8,HX8/A,LH,LH/A,LHB1,LHB3,LHB5,LHE,LHE/A,LW,LW/A,LX,LX/A,LXE,LXE/A,LXE8,LXE8/A,LXU,LXU/A,LXZ,LX16,L1,L1/A,PA,PAE2,PAE2/A,PA2,PA2/A,PX,PX/A,PXE8,PXE8/A,PXU,PXU/A,PX26,PX26/A,QA,QAB1,QAB3,QAB3/A,QAE,QAE2,QAE2/A,QAE6,QAE6/A,QAG,QAG/A,QAG2,QAG2/A,QAQ,QAR2,QAR2/A,QAW,QA2,QD,QD/A,QH,QH/A,QHB5,QHC,QHE,QHP1,QHP1/A,QHZ,QHZ/A,QH26,QH26/A,QKE4,QL2,QMH,QMH/A,QP,QP/A,QSC,QSC9,QSC9/A,QSE,QSE/A,QSE2,QSE8,QSE8/A,QWA2,QWA4,QWA4/A,QWH2,QWH2/A,QX,QX/A,QXB6,QXB6/A,QXC,QXC6,QXC6/A,QXC9,QXE,QXE/A,QXEB,QXE6,QXE6/A,QXE8,QXE8/A,QXU,QXU/A,QX26,QX26/A,Q1,Q1/A,Q2,RA,RA2,RA2/A,RD,RD/A,RH,RHE,RH26,RH26/A,RSC2,RSC2/A,RX,RX/A,RXU,RXU/A,R1,R1/A,SD,SD/A,SH,SH/A,SHE,SHEZ,SMD,SMX2,SN,SN/A,SW,SWC4/A,SWE,SX,SX/A,SXE,SXE/A,SXE8,SXE8/A,SXU,SXU/A,SX2,VA,VAG2,VAG2/A,VAW,VAW1,VA2,VA2/A,VDE,VDE2,VDE2/A,VD16,VH,VKB2,VKB2/A,VME2,VME2/A,VM2,VM2/A,VNT2,VNT2/A,VVA,VVA2,VVA2/A,VVN2,VVN2/A,VW12,VW12/A,VW22,VX,VX/A,VXB2,VXB6,VXE,VXE6,VXE6/A,VXT1,VXT1/A,VXU,VXU/A,VXU1,VXU1/A,VX26,V1,WMT8/A,WXE8,WXE8/A,W1,W1/A
			1	-	-	1340170	SWC4
			1	-	-	1110060	QE,QXB,SE,SXB,SXEB,VNG1,VSD,VXB,VXEB,VXG
			1	-	-	2375749	QAW/A,QA2/A,QXC9/A
11	87528-883-661	MARK, CHOKE	-	-	1	-----	
12	87528-898-620	MARK, CHOKE	1	-	-	-----	ES3,ES3/A,VKE4,VKX4,VMS2,VMT,VMT/A,VMX2,VPE4,VPE4/A,VPE5,VPE7,VPE7/A,VPX4,VPX4/A,VPX5,VPX7,VPX7/A,VSD3/A,VS37,VS37/A
			1	-	-	1056015	VSD3
13	87530-ZH9-810	LABEL, SPECIFICATION (EXTERNAL)	1	(1)	-	1053286	HH,HX,LH,LHE,LW,LX,LXZ,L1,PX,QD,QE,QH,QHC,QHE,QP,QX,QXB,QXE,QXEB,Q1,Q2,RD,RH,RHE,RX,R1,SD,SE,SH,SHE,SHEZ,SW,SWE,SX,SXB,SXE,SXEB,VH,VNG1,VSD,VSD3,VX,VXB,VXE,VXEB,V1,W1
			1	-	-	-----	HA,HAQ,HEA,PA,QA,QAE,QAQ,QXC,RA,VA,VAW,VWA



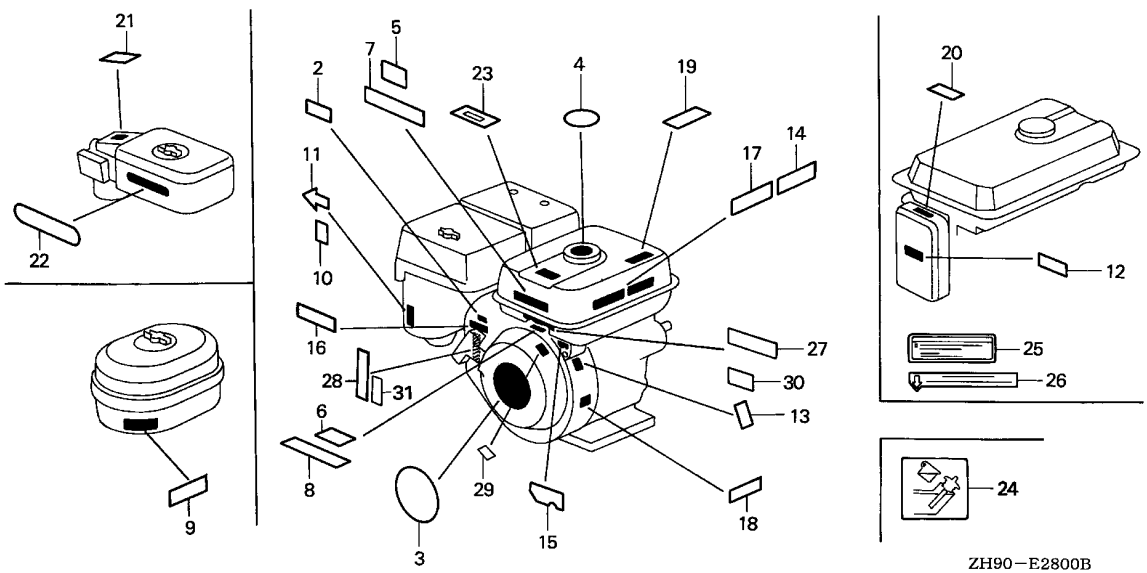

Ref. No.	Part No.	Description	Reqd. QTY			Serial No.	Parts catalogue code	
			(1)	(2)	(3)			
14	87532-ZB4-G60	MARK, OIL ALERT (GERMAN)	1	(1)	-	-----	HEA2,HX26,HX8,LXE,LXE8,LXU,LX16,L1/A,PXU,PX26,QAE6,QAR2,QXE6,QXE8,QXU,QX26,Q1/A,RSC2,RXU,R1/A,SXE8,SXU,SX2,VAW1,VDE,VWN2,VW12,VXB2,VXB6,VXG,VXU,VXU1,VX26,W1/A	
			1	(1)	-	1055455	-----	HA,HAQ,HA2,HEA,HX,LX,LXZ,L1,PA,PX,QA,QAE,QAE2,QAQ,QA2,QX,QXB,QXE,QXEB,Q1,Q2,RA,RX,R1,SX,SXB,SXE,SXEB,VA,VAW,VNG1,VSD,VSD3,VX,VXB,VXE,VXEB,V1,W1
			1	(1)	-	-----	-----	HEA2,HX26,HX26/A,HX8,LXE,LXE8,LXU,LX16,L1/A,PXU,PX26,PX26/A,QAE6,QAE6/A,QAR2,QXB6,QXB6/A,QXC6,QXC6/A,QXE6,QXE6/A,QXE8,QXU,QX26,QX26/A,RSC2,RXU,R1/A,SXE8,SXU,SX2,VAW1,VDE,VD16,VEB6,VWN2,VW12,VXB2,VXB6,VXU,VXU1,VX26
			1	(1)	-	1055455	-----	HA,HAQ,HA2,HEA,HX,LX,LXZ,L1,PA,PX,QA,QAE,QAE2,QAQ,QA2,QX,QXE,QXEB,RA,RX,R1,SX,SXE,VA,VAW,VX,VXE
			1	-	-	-----	1106273	VXG
			1	-	-	1055455	1106273 QXB,SXB,SXEB,VNG1,VSD,VXB,VXEB	
			1	-	-	1055455	1119302 VSD3	
			-	(1)	-	1055455	1177486 Q1,Q2,V1,W1	
15	87532-ZE1-810	MARK, OIL ALERT (EXTERNAL) ..	1	(1)	-	-----	1033679 HA,HX,LX,LXZ,L1,PA,PX,QA,QX,QXB,QXC,Q1,Q2,RA,RX,R1,SX,SXB,VA,VAW,VNG1,VSD,VX,VXB,V1,W1	
			1	-	-	1056015	-----	VSD3
16	87532-ZH7-000	MARK, THROTTLE INDICATION ...	1	-	-	-----	VMA4,VME4	

Ref. No.	Part No.	Description	Reqd. QTY			Serial No.	Parts catalogue code	
			(1)	GX270 (2)	(3)			
16)	87532-ZH8-W40	MARK, THROTTLE INDICATION ...	1	-	-	-----	HXQ4, HXQ4/A, LHQ4, LXQ4, LXQ4/A, QAQ4, QAQ4/A, QE/A, QHE4, QHE4/A, QHQ4, QHQ4/A, QHR, QHR/A, QHR4, QHR4/A, QKE3, QKE3/A, QKE4, QME2, QME2/A, QWA4, QWA4/A, QXB/A, QXB7, QXB7/A, QXC4, QXC4/A, QXE4, QXE4/A, QXQ4, QXQ4/A, RHE4, RHE4/A, RHQ4, RHQ4/A, RXQ4, RXQ4/A, SE/A, SHQ4, SHQ4/A, SMC4, SMC4/A, SME1, SME1/A, SME6, SME6/A, SWA4, SWC4, SWC4/A, SXB/A, SXB7, SXB7/A, SXEB/A, SXE4, SXE4/A, SXQ4, SXQ4/A, VD16, VEB6, VNG1/A, VN17, VN17/A, VXB/A, VXB7, VXB7/A, VXEB/A, VXE4, VXE4/A, VXE7, VXE7/A, VXQ4, VXQ4/A, VXTB, WMA4	
			1	-	-	1110061	-----	QE, QXB, SE, SXB, SXEB, VNG1, VXB, VXEB
			1	-	-	2375750	-----	QAW/A, QA2/A, QXC9/A
			1	-	-	1110061	1116416	VSD, VSD3, VXG
			-	-	1			
17	87532-ZH8-810	MARK, OIL ALERT (EXTERNAL) ..	1	(1)	1	-----	-----	ES1, ES1/A, HAP, HAP/A, HAQ, HA2, HA2/A, HEA, HEA2, HEA2/A, HEA8, HEA8/A, HX/A, HX26, HX26/A, HX8, HX8/A, LX/A, LXE, LXE/A, LXEB, LXEB/A, LXU, LXU/A, LX16, L1/A, PAE2, PAE2/A, PA2, PA2/A, PX/A, PXE8, PXE8/A, PXU, PXU/A, PX26, PX26/A, QAB1, QAB3, QAB3/A, QAE, QAE2, QAE2/A, QAE6, QAE6/A, QAG, QAG/A, QAG2, QAG2/A, QAQ, QAR2, QAR2/A, QAW, QAW/A, QA2, QA2/A, QKE4, QL2, QSC, QSC9, QSC9/A, QSE, QSE/A, QSE2, QSE8, QSE8/A, QWA2, QWA4, QWA4/A, QWH2, QWH2/A, QX/A, QXB6, QXB6/A, QXC6, QXC6/A, QXC9, QXC9/A, QXE/A, QXE6, QXE6/A, QXE8, QXE8/A, QXU, QXU/A, QX26, QX26/A, Q1/A, Q2, RA2, RA2/A, RSC2, RSC2/A, RX/A, RXU, RXU/A, R1/A, SMD, SMX2, SWC4/A, SX/A, SXE/A, SXE8, SXE8/A, SXU, SXU/A, SX2, VAW1, VA2, VA2/A, VDE, VDE2, VDE2/A, VD16, VEB6, VKB2, VKB2/A, VME2, VME2/A, VM2, VM2/A, VNT2, VNT2/A, VWN2, VWN2/A, VW12, VW12/A, VW22, VX/A, VXB2, VXB6, VXE6, VXE6/A, VXU, VXU/A, VXU1, VXU1/A, VX26, WMT8, WMT8/A, WXE8, WXE8/A, W1/A
			1	(1)	-	1033680	-----	HA, HX, LX, LXZ, L1, PA, PX, QA, QX, QXC, QXE, QXEB, Q1, RA, RX, R1, SX, SXE, VA, VAW, VX, VXE, V1, W1
			1	-	-	1340170	-----	SWC4
			1	-	-	1106273	1106273	VSD3, VXG
			1	-	-	1033680	1106273	QXB, SXB, SXEB, VNG1, VSD, VXB, VXEB
18	87532-ZH8-810	MARK, OIL ALERT (EXTERNAL) ..	1	-	1	-----	-----	RXP, RXP/A, VAG2, VAG2/A, VMS2, VMX2, VXP, VXP/A, VXT1, VXT1/A
19	87532-ZH9-W40	MARK, ENGINE SWITCH (EC)	1	-	-	-----	-----	VS37
			1	-	-	1119303	-----	VSD3
	87532-ZH9-W41	MARK, ENGINE SWITCH	1	-	-	-----	-----	VSD3/A, VS37/A
20	87533-ZA7-650	MARK, AIR CLEANER	1	-	-	1056015	1106273	VSD3
21	87534-ZE1-841	LABEL, AIR CLEANER CAUTION ..	1	-	-	-----	-----	QHC, QSC, QSC9, QSC9/A, QWA2, QWA4, QWA4/A, QWH2, QWH2/A, QXC, QXC6, QXC6/A, QXC9, QXC9/A
			-	(1)	-			
22	87535-ZE1-840	MARK, AIR CLEANER SALES POINT	1	-	-	-----	-----	QHC, QSC, QSC9, QSC9/A, QWA2, QWA4, QWA4/A, QWH2, QWH2/A, QXC, QXC4, QXC4/A, QXC6, QXC6/A, QXC9, QXC9/A
			-	(1)	-			
	87535-ZE1-841	1	-	-	-----	-----	VMA4, VME4
23	87565-ZE2-810	MARK, FUEL INDICATION (ENGLISH)	1	(1)	-	-----	-----	L1, L1/A, QKE3, QKE3/A, QKE4, QSC, QSC9, QSC9/A, Q1, Q1/A, Q2, R1, R1/A, V1, W1, W1/A
			1	-	-	1123181	-----	VXG
	87565-ZE2-A01	MARK, FUEL INDICATION (PICTOGRAPH)	1	-	-	1123182	-----	VXG
24	87594-ZB4-A00	MARK, OIL CAUTION	1	-	-	-----	-----	ES1, ES1/A
25	87533-ZC0-630	MARK, AIR CLEANER	1	-	-	-----	-----	ES3, ES3/A, VMT, VMT/A, VS3
26	87539-898-620	MARK, EX. CAUTION (ENGLISH/FRENCH)	1	-	-	-----	-----	ES3, ES3/A, VMT, VMT/A, VS3



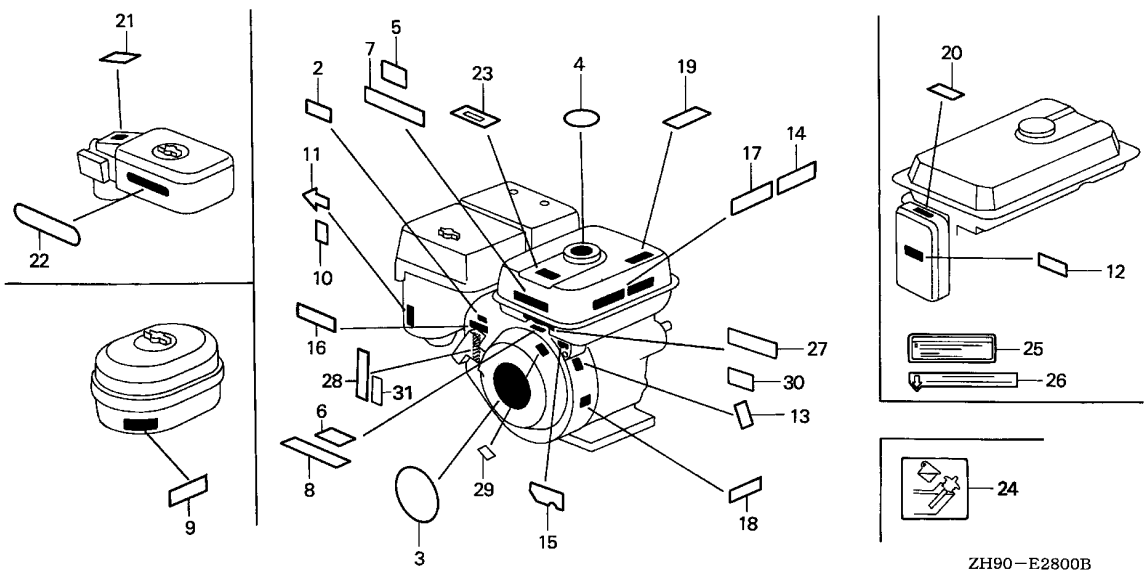

ZH90-E2800B

Ref. No.	Part No.	Description	Reqd. QTY			Serial No.	Parts catalogue code
			(1)	(2)	(3)		
27	87135-ZE2-000	LABEL, E-SPEC (HONDA) (EPA STANDARD)(15.5X60.0)	1	1	-	1703189	----- ES1,HX,HX8,LH,LHE,LT,LW,LX,LXE,LXE8,LXU,L1,PX,PXE8,PXU,QAB3,QD,QE QH,QHP1,QHR,QHR4,QHZ,QKE3,QMH,QP,QSE,QSE8,QX,QXB,QXE,QXE8,QXU,Q1 RD,RX,RXU,R1,SD,SE,SH,SMC4,SME1,SME6,SX,SXB,SXE,SXEB,SXE8,SXU,S1 VSD,VX,VXB,VXEB,VXTB,VXU,VXU1,WMT8,WXE8
			1	-	-	1703189 1841642	HXQ4,LXQ4,QAQ4,QHE4,QHQ4,QME2,QXC4,QXE4,QXQ4,RHQ4,RHQ4,RXQ4,SHQ4 SXE4,SXQ4,VXE4,VXQ4
	87135-ZE2-010	LABEL, E-SPEC (EPA STANDARD) (15.5X60.0)	1	-	-	-----	QKE4,QSE2,QXB7,SXB7,VPX7,VSD7,VS37,VXB7,VXE7
			1	-	-	1841643	----- HXQ4,LXQ4,QAQ4,QHE4,QHQ4,QME2,QXC4,QXE4,QXQ4,RHQ4,RXQ4,SHQ4,SXE4 SXQ4,VXE4,VXQ4
28	87135-ZE2-000	LABEL, E-SPEC (HONDA) (EPA STANDARD)(15.5X60.0)	1	-	-	1703189	----- ES3,QKE4,QSE2,SKE1,VMT,VNG1,VPE4,VPX4,VSD3,VWT4,VXT1
			1	-	-	1841642	VN17,VPE7
	87135-ZE2-020	LABEL, E-SPEC (15.5X27.5) ...	1	-	-	-----	ES3/A,SWA4,VMT/A,VS3,VXT1/A
			1	-	-	1841643	VN17,VPE7
			1	-	-	2297651	VKE4,VKX4,VNG1/A,VN17/A,VPE4/A,VPE7/A,VPX4/A,VSD3/A,VWT4/A
29	87106-ZE9-V00	LABEL, FUEL CAUTION	-	-	1	-----	HAP,HAP/A

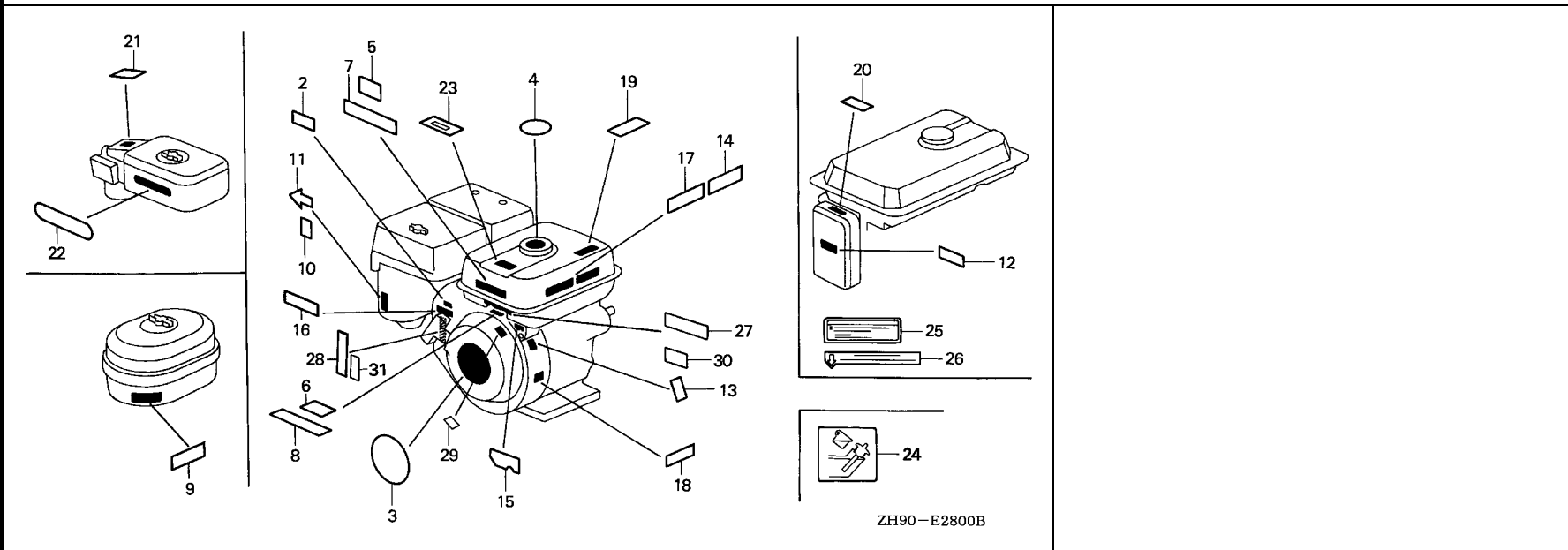

Ref. No.	Part No.	Description	Reqd. QTY			Serial No.	Parts catalogue code
			(1)	(2)	(3)		
30	87135-ZE2-020	LABEL, E-SPEC (15.5X27.5) ...	1	1	1	-----	ESS/A,ES1/A,HX/A,HX8/A,LH/A,LHB5,LHE/A,LJ/A,LJC/A,LJG/A,LT/A,LW/A,LWD1/A,LX/A,LXE/A,LXE8/A,LXU/A,L1,L1/A,PX/A,PXE8/A,PXU/A,QAB3/A,QD/A,QH/A,QHB5,QHP1/A,QHZ/A,QMH/A,QP/A,QSE/A,QSE8/A,QX/A,QXE/A,QXE8/A,QXU/A,Q1/A,RD/A,RSS/A,RX/A,RXP/A,RXU/A,R1,R1/A,SD/A,SH/A,SJ/A,SJG/A,SME1,SWA4,SX/A,SXE/A,SXE8/A,SXU/A,S1,S1/A,VX/A,VXP/A,VXU/A,VXU1/A,WMT8/A,WXE8/A,W1/A
			1	-	-	1841643	RHE4
			1	-	-	2297651	HXQ4/A,LXQ4/A,QAQ4/A,QE/A,QHE4/A,QHQ4/A,QHR/A,QHR4/A,QKE3/A,QME2/A,QXB/A,QXB7/A,QXC4/A,QXE4/A,QXQ4/A,RHE4/A,RHQ4/A,RXQ4/A,SE/A,SHQ4/A,SMC4/A,SME1/A,SME6/A,SXB/A,SXB7/A,SXEB/A,SXE4/A,SXQ4/A,VPX7/A,VSD/A,VSD7/A,VSH7,VS37/A,VXB/A,VXB7/A,VXEB/A,VXE4/A,VXE7/A,VXQ4/A
31	87114-ZH7-000	LABEL, WARNING (NOT CERTIFIED FOR SALE)	1	1	-	2359274	HX/A,LHB5,LJ/A,LJC/A,LJG/A,LT/A,LWD1/A,LX/A,L1/A,PX/A,QAB3/A,QD/A,QHB5,QHP1/A,QHZ/A,QMH/A,QP/A,QT/A,QX/A,QXE/A,Q1/A,RD/A,RSS/A,RX/A,R1/A,SD/A,SJG/A,SN/A,SX/A,SXE/A,S1/A,VMT/A,VX/A,VXT1/A,W1/A
			1	-	-	2397962	VS3
			1	-	-	2401383	ESS/A,ES1/A,ES3/A,LH/A,LHE/A,LW/A,LXE/A,QH/A,QSE/A,SH/A,SJ/A,VXU/A,WMT8/A,WXE8/A



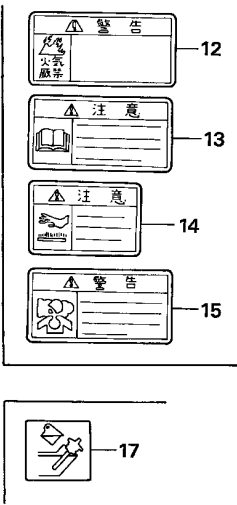
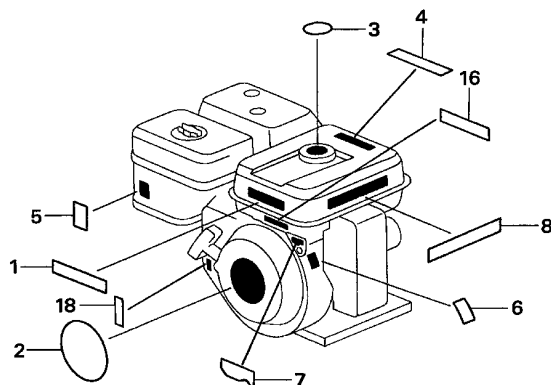
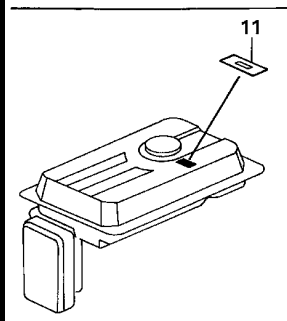

ZH90-E2801

Ref. L.O.N. (Relative ref. Number) F.R.T.
No. Description

NO INFORMATION

Ref. No.	Part No.	Description	Reqd. QTY			Serial No.	Parts catalogue code	
			(1)	(2)	(3)			
1	87520-ZH8-000	MARK A, COMBINATION	1	(1)	-	-----	LJ/A,LJC,LJC/A,LJG/A,LWD1,LWD1/A,L1/A,Q1/A,RSS,RSS/A,R1/A,SJ/A SJG/A,S1/A,W1/A	
			1	(1)	-	1143651	-----	LJG,LSS,LTJ,LWD,L1,Q1,R1,SJ,SJG,SJP,SK,S1,V1,W1
			1	-	-	1164474	-----	LJ
2	87521-ZH9-000	EMBLEM (INTERNAL)	1	(1)	-	1033679	-----	LJ,L1,Q1,R1,SJ,SJP,SK,S1,V1,W1
	87521-ZH9-010	EMBLEM	1	(1)	-	-----	-----	LJC,LJG,LSS,LTJ,Q1/A,RSS,SJG,S1/A,W1/A
			1	(1)	-	1033680	-----	LJ,L1,Q1,R1,SJ,SJP,SK,S1,V1,W1
	87521-ZH9-020	1	(1)	-	-----	-----	ESS/A,LJ/A,LJC/A,LJG/A,L1/A,RSS/A,R1/A,SJ/A,SJG/A
3	87522-ZE1-010	LABEL, FUEL WARNING	1	(1)	-	1054062	-----	LJ,LWD,L1,Q1,R1,SJ,SK,S1,V1,W1
	87522-ZE1-810	MARK, CAUTION	1	(1)	-	1090815	-----	LTJ,L1,Q1,S1,V1,W1
			1	-	-	1054063	-----	LJ,LWD,SJ,SK
4	87526-ZH8-000	MARK B, COMBINATION	1	(1)	-	-----	-----	LJ/A,LJC,LJC/A,LJG/A,LWD1,LWD1/A,L1/A,Q1/A,RSS,RSS/A,R1/A,SJ/A SJG/A,S1/A,W1/A
			1	(1)	-	1143651	-----	LJG,LSS,LTJ,LWD,L1,Q1,R1,SJ,SJG,SJP,SK,S1,V1,W1
			1	-	-	1164474	-----	LJ
5	87528-ZE2-000	MARK, CHOKE (INTERNAL)	1	(1)	-	1053286	-----	LJ,LWD,L1,Q1,R1,SJ,SJP,SK,S1,V1,W1
	87528-ZE2-810	MARK, CHOKE (ORANGE)	1	-	-	-----	-----	LJ/A,LJC,LJC/A,LJG,LJG/A,LTJ,LWD1,LWD1/A,RSS,RSS/A,SJ/A,SJG,SJG/A
			1	-	-	1053287	-----	LJ,LWD,SJ,SJP,SK
6	87530-ZH9-000	LABEL, SPECIFICATION (INTERNAL)	1	(1)	-	-----	-----	Q1,Q1/A,SJ,SJG,SJP,SK,V1,W1,W1/A
			-	(1)	-	2019729	-----	R1,S1
	87530-ZH9-840	LABEL, SPECIFICATION (INTERNAL/L-TYPE)	1	-	-	-----	-----	LJG,LSS,LTJ
			1	-	-	2035958	-----	LJG/A
	87530-ZH9-010	LABEL, SPECIFICATION	-	(1)	-	-----	-----	R1/A,S1/A
			-	(1)	-	2019730	-----	R1,S1
	87530-ZH9-841	1	(1)	-	-----	-----	LJ,LJ/A,LJC,LJC/A,LWD1,LWD1/A,L1,L1/A
			1	-	-	2035959	-----	LJG/A

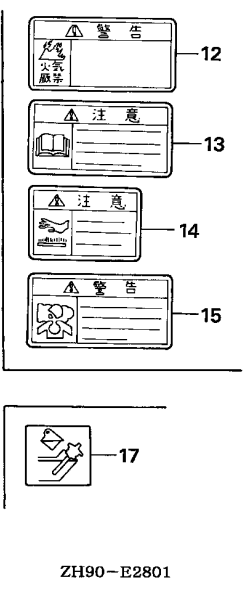
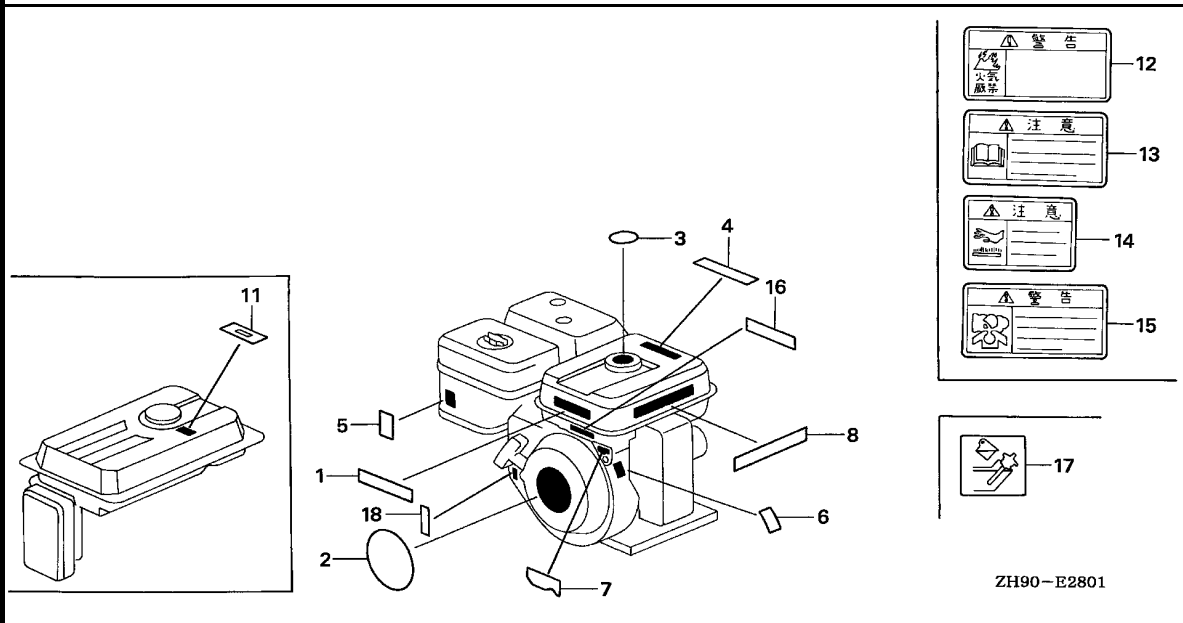

ZH90-E2801

Ref. No.	Part No.	Description	Reqd. QTY			Serial No.	Parts catalogue code
			(1)	(2)	(3)		
7	87532-ZE1-000	MARK, OIL ALERT (INTERNAL) ..	1	(1)	-	1033679	L1,Q1,R1,SJP,S1,V1,W1
8	87532-ZB4-G60	MARK, OIL ALERT (GERMAN)	-	(1)	-	-----	L1/A,Q1/A,R1/A,S1/A,W1/A
	87532-ZB4-H50	MARK, OIL ALERT (FRENCH)	-	(1)	-	1055455	L1,Q1,R1,S1,V1,W1
			-	(1)	-	-----	L1/A,R1/A
			-	(1)	-	1055455	L1,R1
			-	(1)	-	1055455	1177486
	87532-ZH8-000	MARK, OIL ALERT (INTERNAL) ..	1	1	-	-----	LJC,LJC/A,L1/A,Q1/A,R1/A,S1/A,W1/A
			1	1	-	1033680	L1,Q1,R1,SJP,S1,V1,W1
11	87565-ZB4-A00	PLATE, FUEL INDICATION	1	-	-	-----	ESS,ESS/A
	87565-ZE2-A01	MARK, FUEL INDICATION (PICTOGRAPH)	1	-	-	1054063	LWD
	87565-ZE2-000	MARK, FUEL INDICATION (JAPANESE)	1	(1)	-	-----	LJ,LJG,LJG/A,LSS,LTJ,LWD1,LWD1/A,L1,L1/A,Q1,Q1/A,R1,R1/A,SJ,SJG
							SJG/A,SK,S1,S1/A,V1,W1,W1/A
12	87561-733-J00	MARK, EX. GAS WARNING	1	-	-	-----	ESS,ESS/A
13	87106-737-J00	MARK, FUEL WARNING	1	-	-	-----	ESS,ESS/A
14	87150-ZH8-000	MARK, CAUTION (JAPANESE)	1	-	-	-----	ESS,ESS/A
15	87539-737-J00	MARK, HEAT CAUTION	1	-	-	-----	ESS,ESS/A
16	87135-ZE2-000	LABEL, E-SPEC (HONDA) (EPA STANDARD)(15.5X60.0)	1	1	-	1703189	LJ,LJC,LJG,LWD,LWD1,L1,Q1,RSS,R1,SJ,SJG,S1
	87135-ZE2-010	LABEL, E-SPEC (EPA STANDARD) (15.5X60.0)	1	1	-	-----	LJ/A,LJC/A,LJG/A,LWD1/A,L1/A,Q1/A,R1/A,SJ/A,SJG/A,S1/A
	87135-ZE2-020	LABEL, E-SPEC (15.5X27.5) ...	1	-	-	-----	RSS/A
17	87594-ZB4-A00	MARK, OIL CAUTION	1	-	-	-----	ESS,ESS/A
18	87135-ZE2-000	LABEL, E-SPEC (HONDA) (EPA STANDARD)(15.5X60.0)	1	-	-	1703189	ESS
	87135-ZE2-010	LABEL, E-SPEC (EPA STANDARD) (15.5X60.0)	1	-	-	-----	ESS/A

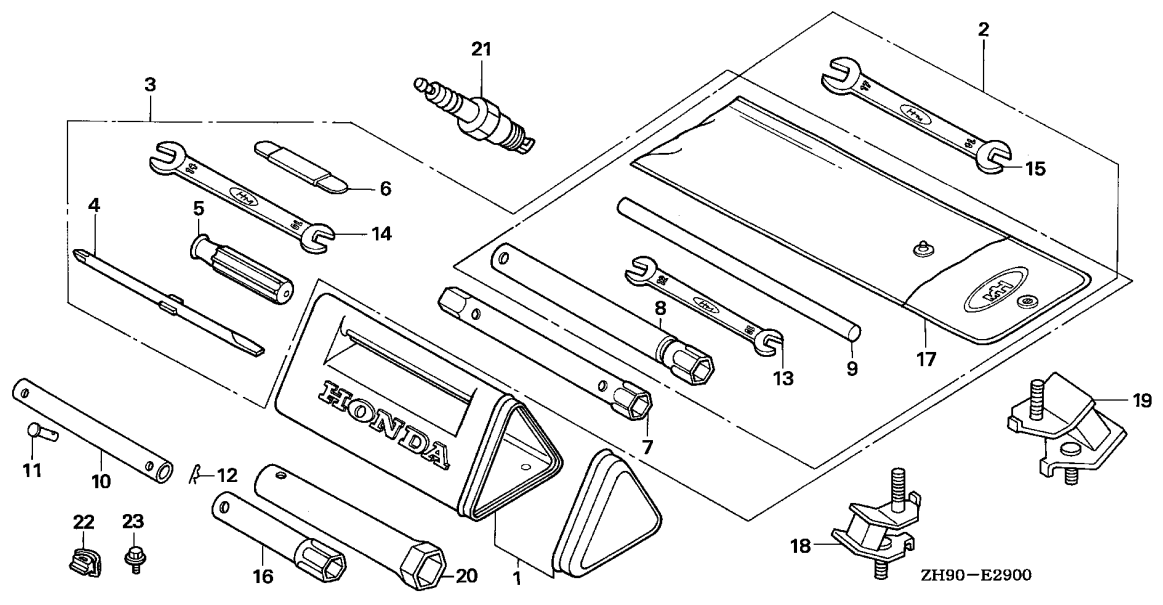

Ref. No.	L.O.N.	(Relative ref. Number) Description	F.R.T.
----------	--------	------------------------------------	--------

NO INFORMATION

Ref. No.	Part No.	Description	Reqd. QTY			Serial No.	Parts catalogue code
			(1)	(2)	(3)		
1	83501-ZF1-000	BOX, TOOL	1	-	-	-----	LHB3,LT,LT/A,LW,LW/A,QAB3,QAB3/A,QHZ,QHZ/A,QT,QT/A,SW,SWE
2	89000-ZE1-000	TOOL KIT	1	-	-	-----	1264036 QP
			1	-	-	-----	1264037 QP
3	89001-ZF1-000	BAG SET, TOOL	1	(1)	-	-----	LHB3,LT,LT/A,LW,LW/A,QAB3,QAB3/A,QHZ,QHZ/A,QT,QT/A,SW,SWE
			1	-	-	-----	1264036 QP
4	89102-538-000	SHAFT, SCREW DRIVER	1	-	-	-----	LHB3,LT,LT/A,LW,LW/A,QAB3,QAB3/A,QHZ,QHZ/A,QT,QT/A,SW,SWE
5	89103-538-000	GRIP	1	-	-	-----	1264036 QP
			1	-	-	-----	LHB3,LT,LT/A,LW,LW/A,QAB3,QAB3/A,QHZ,QHZ/A,QT,QT/A,SW,SWE
			1	-	-	-----	1264036 QP
6	89210-ZF1-000	GAUGE ASSY., THICKNESS	1	-	-	-----	LHB3,LT,LT/A,LW,LW/A,QAB3,QAB3/A,QHZ,QHZ/A,QT,QT/A,SW,SWE
			1	-	-	-----	1264036 QP
7	89216-ZF1-000	WRENCH, BOX	1	-	-	-----	LHB3,LT,LT/A,LW,LW/A,QAB3,QAB3/A,QHZ,QHZ/A,QT,QT/A,SW,SWE
			1	-	-	-----	1264036 QP

2

Ref. No.	Part No.	Description	Reqd. QTY			Serial No.	Parts catalogue code
			(1)	(2)	(3)		
8	89218-ZE1-000	WRENCH COMP., SPARK PLUG	1	-	(1)		ES1,ES1/A,HAP,HAP/A,HAQ,HA2,HA2/A,LHB3,LT,LT/A,LW,LW/A,PA2,PA2/A,QAB3,QAB3/A,QAE2,QAE2/A,QAQ,QA2,QA2/A,QE,QE/A,QHP1,QHP1/A,QHZ,QHZ/A,QMH,QMH/A,QP,QP/A,QSC,QSC9,QSC9/A,QT,QT/A,RA2,RA2/A,SMC4,SMC4/A,SMX2,SW,SWE,VA2,VA2/A,VDE,VDE2,VDE2/A,VKE4,VKX4,VNG1,VNG1/A,WMA4,WMT8,WMT8/A,WXE8,WXE8/A
			1	-	-	3181387	HA,HEA,PA,QA,QAE,RA,VA,VAW,VWA
			(1)	-	-		HEA2,HEA2/A,HEA8,HEA8/A,PAE2,PAE2/A,QAB1,QAE6,QAE6/A,QAG,QAG/A,QAG2,QAG2/A,QAQ4,QAQ4/A,QAR2,QAR2/A,QAW,QAW/A,QL2,QX26,QX26/A,RSC2,RSC2/A,SE,SE/A,SKE1,VAG2,VAG2/A,VAW1,VKB2,VKB2/A,VME2,VME2/A,VM2,VM2/A,VNT2,VNT2/A,VN17,VN17/A,VWA2,VWA2/A,VWN2,VWN2/A,VW12,VW12/A,VW22
			-	(1)	-		
			1	-	-		SMX2,VKE4,VKX4,WMA4
			(1)	-	-	3181388	HA,HEA,PA,QA,QAE,RA,VA,VAW,VWA
9	89219-805-000	HANDLE, BOX WRENCH	1	-	-		LHB3,LT,LT/A,LW,LW/A,QAB3,QAB3/A,QHP1,QHP1/A,QHZ,QHZ/A,QMH,QMH/A,QP,QP/A,QT,QT/A,SW,SWE,WMA4,WMT8,WMT8/A,WXE8,WXE8/A
10	89220-ZE2-000	PIPE, BOX WRENCH EXTENSION	-	(1)	-		
11	90755-758-L00	PIN, ROLLER ARM, 8X22	-	(1)	-		
12	94252-08000	PIN, LOCK, 8MM	-	(1)	-		
13	99001-10120	SPANNER, 10X12	1	-	-		LHB3,LT,LT/A,LW,LW/A,QAB3,QAB3/A,QHP1,QHP1/A,QHZ,QHZ/A,QMH,QMH/A,QP,QP/A,QT,QT/A,SW,SWE,WMA4,WMT8,WMT8/A,WXE8,WXE8/A
			-	(1)	-		
14	99001-10140	SPANNER, 10X14	1	-	-		LHB3,LT,LT/A,LW,LW/A,QAB3,QAB3/A,QHZ,QHZ/A,QT,QT/A,SW,SWE
			1	-	-	1264036	QP
15	99001-14170	SPANNER, 14X17	1	-	-		QHP1,QHP1/A,QMH,QMH/A,QP/A,WMA4,WMT8,WMT8/A,WXE8,WXE8/A
			1	-	-	1264037	QP
			-	(1)	-		
16	99004-21003	WRENCH, BOX (P21)	-	(1)	-		
17	99008-02300	BAG, TOOL, 230MM	1	-	-		LHB3,LT,LT/A,LW,LW/A,QAB3,QAB3/A,QHP1,QHP1/A,QHZ,QHZ/A,QMH,QMH/A,QP,QP/A,QT,QT/A,SW,SWE,WMA4,WMT8,WMT8/A,WXE8,WXE8/A
			-	(1)	-		
18	68325-ZB4-000	RUBBER, BOTTOM	2	-	-		ES1,ES1/A,ES3,ES3/A,VS3
19	68325-899-000	RUBBER, BOTTOM	2	-	-		ES1,ES1/A,ES3,ES3/A,VS3
20	89216-ZB4-000	WRENCH, PLUG	1	-	-		ES3,ES3/A,VMT,VMT/A,VS3
21	98079-56841	PLUG, SPARK (BP6ES)(NGK)	1	-	-		ES3,ES3/A
	98079-55846	PLUG, SPARK (BPR5ES)(NGK)	1	-	-		VS3
22	90855-ZB4-000	GROMMET, CRANKCASE	1	-	-		VMT,VMT/A
23	95701-06010-00	BOLT, FLANGE, 6X10	8	-	-		VMT,VMT/A



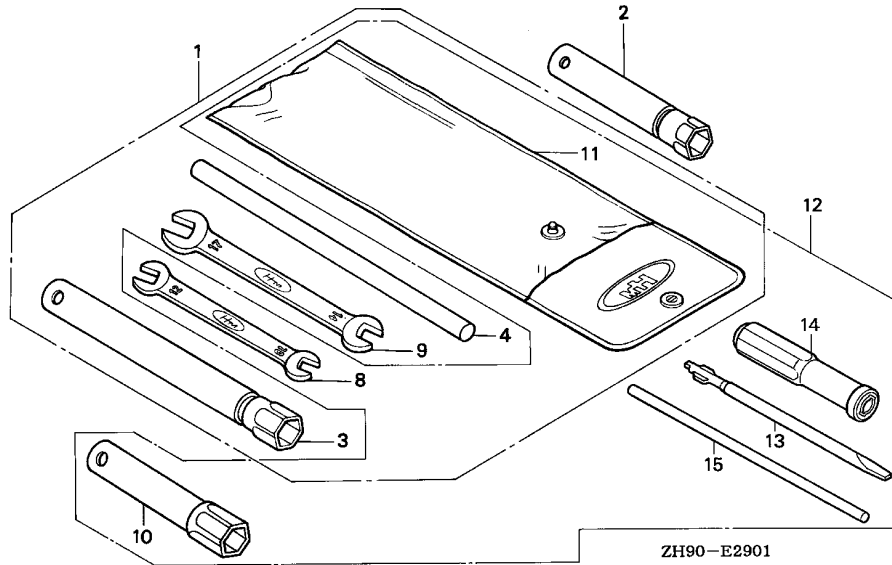

Ref. L.O.N. (Relative ref. Number) F.R.T.
No. Description

NO INFORMATION

ZH90-E2901

Ref. No.	Part No.	Description	Reqd. QTY			Serial No.	Parts catalogue code
			(1)	(2)	(3)		
1	89000-ZE1-000	TOOL KIT	1	-	-	-----	LWD1,LWD1/A
2	89216-809-000	WRENCH COMP., SPARK PLUG	1	-	-	-----	SJP
3	89218-ZE1-000	WRENCH COMP., SPARK PLUG	1	-	-	-----	LJ,LJ/A,LJC,LJC/A,LJG,LJG/A,LSS,LTJ,LWD1,LWD1/A,SJ,SJ/A,SJG,SJG/A
4	89219-805-000	HANDLE, BOX WRENCH	(1)	-	-	-----	RSS,RSS/A
8	99001-10120	SPANNER, 10X12	1	-	-	-----	LWD1,LWD1/A
9	99001-14170	SPANNER, 14X17	1	-	-	-----	ESS/A,LHB5,LWD1,LWD1/A,QHB5
10	99004-21003	WRENCH, BOX (P21)	1	-	-	1274337	ESS
11	99008-02000	BAG, TOOL, 200MM	1	-	-	-----	LWD1,LWD1/A
	99008-02300	BAG, TOOL, 230MM	1	-	-	1274337	ESS/A,LHB5,QHB5
12	89000-ZB6-000	TOOL KIT	1	-	-	-----	ESS
13	99003-30000	DRIVER MINUS SCREW 3,(NO.2)	1	-	-	1274337	ESS/A,LHB5,QHB5
14	99003-50000	GRIP, SCREW DRIVER	1	-	-	-----	ESS
15	99005-01000	BAR A, HANDLE	1	-	-	1274337	ESS/A,LHB5,QHB5
			1	-	-	-----	ESS

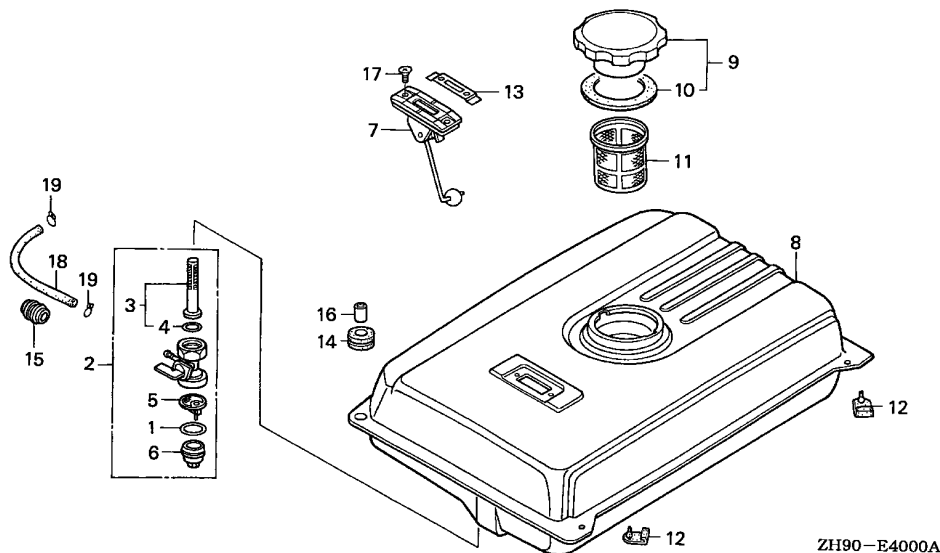

Ref. No.	L.O.N.	(Relative ref. Number) Description	F.R.T.
1	3101L6	PACKING, FUEL STRAINER CUP ...	0.2
2	3101A3	COCK, FUEL	0.2
3	3101D5	SCREEN, FUEL STRAINER	0.2
5	3101A7	FILTER, FUEL TANK CUP	0.2
7	6171A1	METER/GAUGE UNIT, FUEL	0.1
8	3101H7	TANK, FUEL	0.2
11	3101A6	FILTER, FUEL	0.1
18	3101F2	TUBE, FUEL COCK	0.2

Ref. No.	Part No.	Description	Reqd. QTY			Serial No.	Parts catalogue code
			(1)	(2)	(3)		
1	16173-001-004	PACKING, FUEL STRAINER CUP ..	1	-	-	-----	VMT,VMT/A
2	16950-ZB4-015	COCK ASSY., FUEL	1	-	-	-----	VMT,VMT/A
3	16952-ZB4-005	SCREEN, FUEL STRAINER	1	-	-	-----	VMT,VMT/A
4	16958-397-771	O-RING	1	-	-	-----	VMT,VMT/A
5	16959-471-831	FILTER, CUP	1	-	-	-----	VMT,VMT/A
6	16967-GA6-671	CUP, FUEL STRAINER	1	-	-	-----	VMT,VMT/A
7	17505-ZB2-003	METER ASSY., FUEL	1	-	-	-----	VMT,VMT/A
8	17510-ZB4-000ZB	TANK COMP., FUEL	1	-	-	-----	VMT,VMT/A
9	17620-899-013	*R8*.....BRIGHT RED CAP COMP., FUEL FILLER	1	-	-	1657671	VMT
10	17631-899-000	PACKING, FUEL FILLER CAP	1	-	-	-----	VMT,VMT/A
11	17672-899-000	FILTER, FUEL	1	-	-	-----	VMT,VMT/A
12	50319-ZB2-000	RUBBER, TANK MOUNTING	2	-	-	-----	VMT,VMT/A
13	87565-ZB4-A00	PLATE, FUEL INDICATION	1	-	-	-----	VMT,VMT/A
14	90851-898-000	RUBBER, TANK CUSHION	2	-	-	-----	VMT,VMT/A
15	90854-ZB2-000	RUBBER, FUEL (9X15X10)	1	-	-	-----	VMT,VMT/A
16	91551-898-000	COLLAR, TANK CUSHION	2	-	-	-----	VMT,VMT/A
17	93600-05010-0A	SCREW, FLAT, 5X10	2	-	-	-----	VMT,VMT/A
18	95001-45250-40	TUBE, FUEL, 4.5X250	1	-	-	-----	VMT,VMT/A
		(95001-45001-60M)	1	-	-	-----	VMT,VMT/A
19	95002-02080	CLIP, TUBE (B8)	2	-	-	-----	VMT,VMT/A



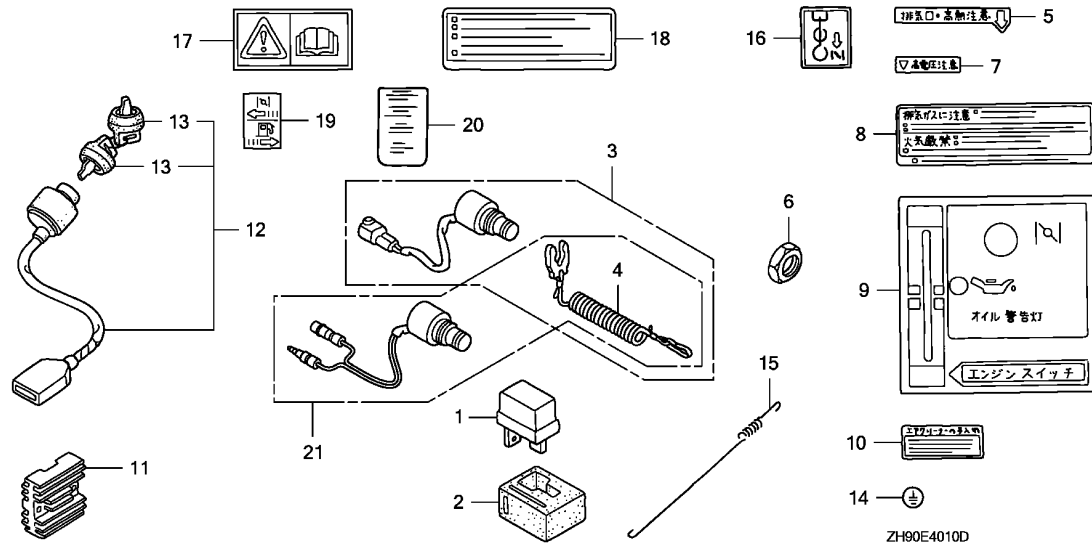

Ref. L.O.N. (Relative ref. Number) F.R.T.
No. Description

NO INFORMATION

Ref. No.	Part No.	Description	Reqd. QTY			Serial No.	Parts catalogue code
			(1)	(2)	(3)		
1	31700-124-008	RECTIFIER ASSY., SILICON (SHINDENGEN)	1	-	-	1097930	LWD
2	32127-738-700	SUSPENSION, COUPLER	1	-	-	1097930	LWD
3	36180-ZV3-003	SWITCH ASSY., EMERGENCY STOP	1	-	-	1097929	LWD
4	36182-ZV4-650	CORD COMP., EMERGENCY	1	-	-		LWD
5	87539-ZB2-000	MARK, EX. CAUTION	1	-	-		ESS,ESS/A
6	90302-921-000	NUT, HEX., 16MM	1	-	-	1097930	LWD
7	87511-892-000	MARK V, CAUTION	1	-	-		ESS,ESS/A
8	87522-892-000	MARK AB, CAUTION	1	-	-		ESS,ESS/A
9	87528-ZB7-700	MARK, ENGINE CONTROL	1	-	-		ESS
	87528-ZB7-701	1	-	-	2341608	ESS/A
10	87533-ZB6-000	MARK, AIR CLEANER	1	-	-	2341609	ESS/A
			1	-	-		ESS,ESS/A
11	31620-762-003	RECTIFIER COMP., REGULATOR ..	1	-	-		LWD1,LWD1/A
12	35100-768-S01	SWITCH ASSY., COMBINATION ...	1	-	-		LWD1,LWD1/A
13	35110-766-003	KEY ASSY., COMBINATION SWITCH	2	-	-		LWD1
			2	-	-	2230574	LWD1/A
	35110-736-612	2	-	-	2230575	LWD1/A
14	87534-892-640	MARK, EARTH	1	-	-		ESS,ESS/A
15	16561-ZE2-A00	SPRING, GOVERNOR	1	-	-	2134946	VXB7/A,VXE7/A
16	87528-898-620	MARK, CHOKE	1	-	-		VS3
17	87522-ZH8-W41	MARK, CAUTION (PICTOGRAPH) ..	1	-	-		VMA4,VME4
			1	-	-	2375750	QAW/A,QA2/A,QXC9/A
18	87522-ZH9-010	LABEL, CAUTION (ENGLISH, ETC.)	1	-	-		VMA4,VME4
19	87528-ZE2-810	MARK, CHOKE (ORANGE)	1	-	-		VMA4,VME4
			1	-	-	2375750	QAW/A,QA2/A,QXC9/A

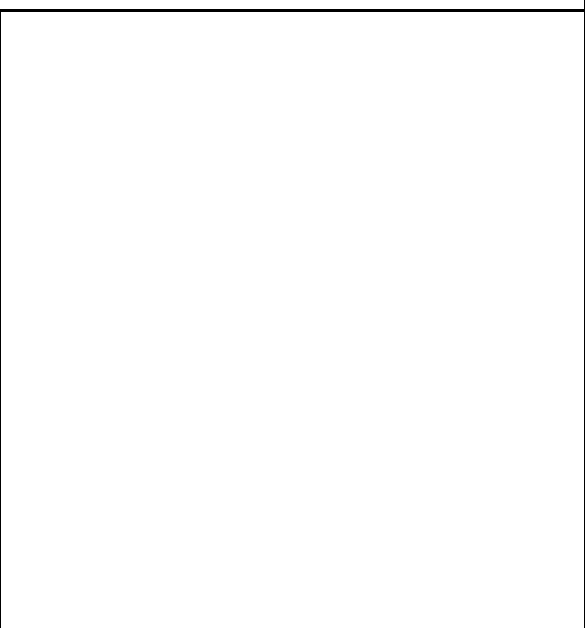
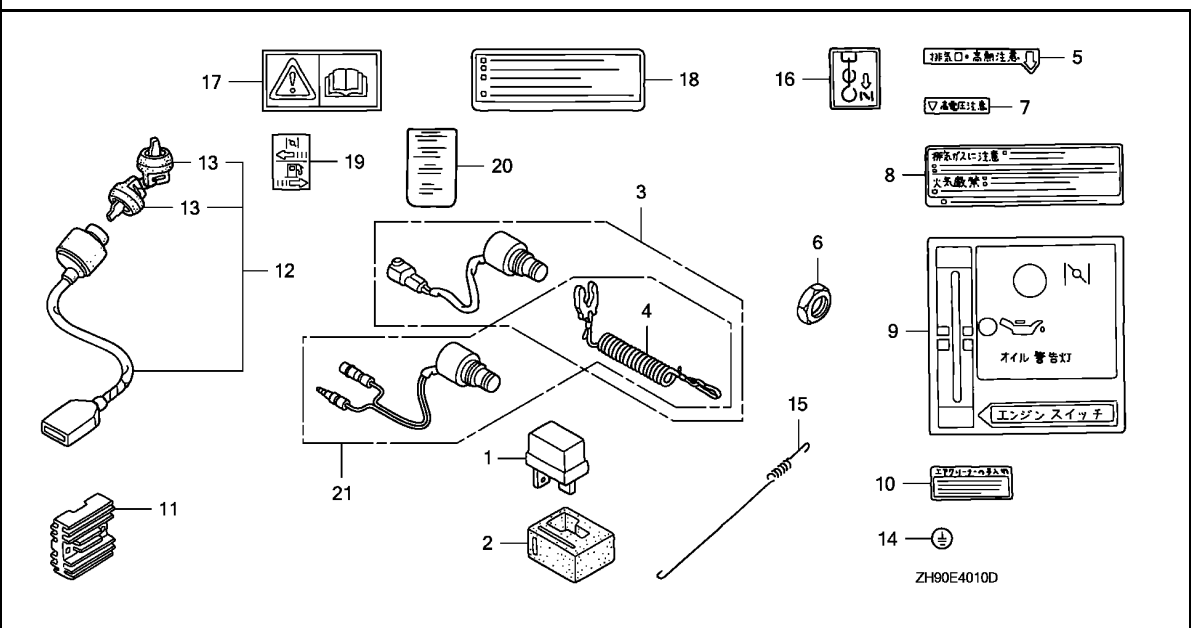

Ref. No.	Part No.	Description	Reqd. QTY			Serial No.	Parts catalogue code
			(1)	(2)	(3)		

19)	87528-ZH7-000	MARK, CHOKE (GRAY)	1	-	-	2375750	----- QAW/A,QA2/A,QXC9/A
20	87534-ZE1-841	LABEL, AIR CLEANER CAUTION ..	1	-	-	-----	----- VMA4,VME4
21	36180-ZV5-013	SWITCH ASSY., EMERGENCY STOP	1	-	-	1097930	----- LWD



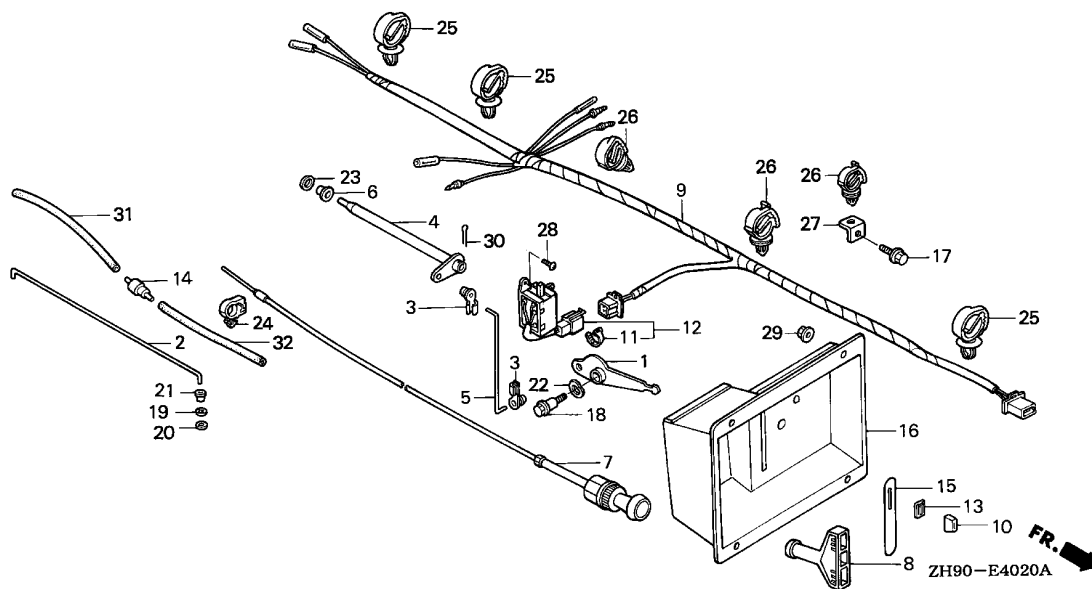

Ref. L.O.N. (Relative ref. Number) F.R.T.
No. Description

NO INFORMATION

Ref. No.	Part No.	Description	Reqd. QTY			Serial No.	Parts catalogue code
			(1)	(2)	(3)		
1	16145-ZB7-700	LEVER COMP., ENGINE SWITCH ..	1	-	-	ESS,ESS/A	
2	16325-ZB7-700	ROD, GOVERNOR CONTROL PUSH ..	1	-	-	ESS,ESS/A	
3	16956-ZA7-000	JOINT, ROD	2	-	-	ESS,ESS/A	
4	16957-ZB7-700	ARM COMP., COCK CONTROL	1	-	-	ESS,ESS/A	
5	16958-ZB7-700	ROD, COCK CONTROL	1	-	-	ESS,ESS/A	
6	16960-ZB7-700	BUSH, COCK CONTROL ARM	1	-	-	ESS,ESS/A	
7	17950-ZB7-702	CABLE COMP., CHOKE	1	-	-	ESS,ESS/A	
8	28461-889-631	GRIP, STARTER	1	-	-	ESS,ESS/A	
9	32100-ZB7-700	HARNESS ASSY., SUB WIRE	1	-	-	ESS,ESS/A	
10	32343-892-003	KNOB, COCK LEVER	1	-	-	ESS,ESS/A	
11	32902-892-003	BAND	1	-	-	ESS,ESS/A	
12	36100-ZB7-701	SWITCH ASSY., KILL	1	-	-	ESS,ESS/A	
13	36106-892-003	BUSH, CONTROL KNOB	1	-	-	ESS,ESS/A	
14	36135-ZV1-003	VALVE, DASHPOT CHECK	1	-	-	ESS,ESS/A	
15	63117-ZB7-700	SEAL, ENGINE SWITCH LEVER ...	1	-	-	ESS,ESS/A	
16	63140-ZB7-700ZA	CASE, RECOIL GRIP	1	-	-	ESS	
		R8.....BRIGHT RED	1	-	-	ESS/A	
	63140-ZB7-700ZB	*R280*.....POWER RED	1	-	-	ESS/A	
17	90013-883-000	BOLT, FLANGE, 6X12(CT200) ...	1	-	-	ESS,ESS/A	
18	90045-PD1-000	BOLT, SPECIAL	1	-	-	ESS,ESS/A	
19	90310-ZB7-701	NUT, PUSH, 2.6	1	-	-	ESS,ESS/A	
20	90433-ZE2-700	WASHER, THRUST, 2.7X8	1	-	-	ESS,ESS/A	
21	90434-ZB7-700	COLLAR, PUSH ROD	1	-	-	ESS,ESS/A	
22	90511-735-801	WASHER, WAVE, 10MM	1	-	-	ESS,ESS/A	
23	90523-GB6-920	WASHER, CENTER COVER	1	-	-	ESS,ESS/A	

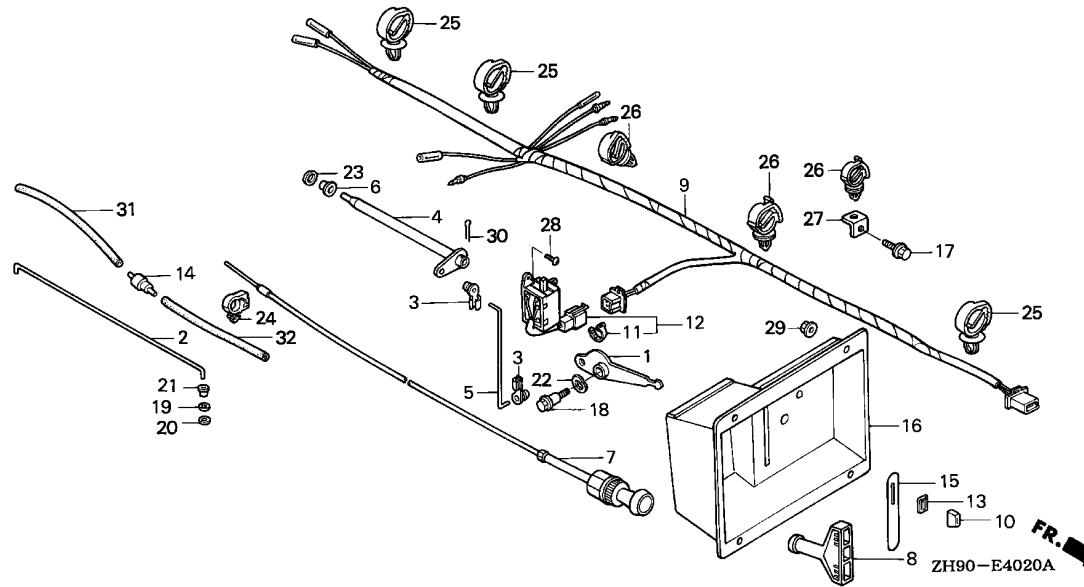

Ref. No.	Part No.	Description	Reqd. QTY			Serial No.	Parts catalogue code
			(1)	(2)	(3)		
24	90650-SD9-003	CLIP, WIRE HARNESS	1	-	-	-----	ESS,ESS/A
25	90683-SA0-003	CLIP, WIRE HARNESS, 25MM	3	-	-	-----	ESS,ESS/A
26	90691-ZB7-003	CLIP, HARNESS	3	-	-	-----	ESS,ESS/A
27	90700-ZB7-000	BASE, CORD CLIP	1	-	-	-----	ESS,ESS/A
28	93500-03008-0A	SCREW, PAN, 3X8	2	-	-	-----	ESS,ESS/A
29	94050-06000	NUT, FLANGE, 6MM	4	-	-	-----	ESS,ESS/A
30	94201-20180	PIN, SPLIT, 2.0X18	1	-	-	-----	ESS,ESS/A
31	95005-35085-10	TUBE, 3.5X85(95005-35001-10M)	1	-	-	-----	ESS,ESS/A
32	95005-35175-10	TUBE, 3.5X175(95005-35001-10M)	1	-	-	-----	ESS,ESS/A



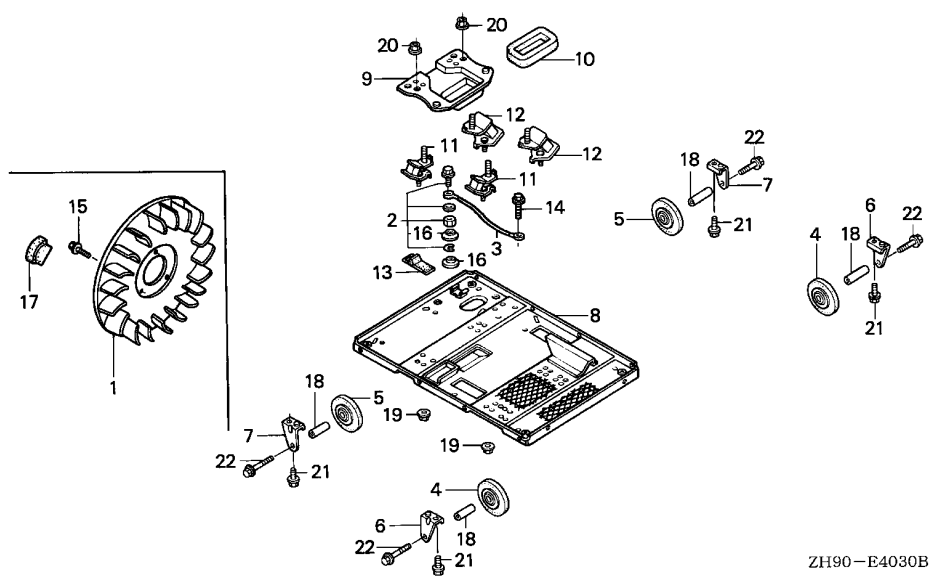

Ref. No.	L.O.N.	(Relative ref. Number)	Description	F.R.T.
----------	--------	------------------------	-------------	--------

NO INFORMATION

Ref. No.	Part No.	Description	Reqd. QTY			Serial No.	Parts catalogue code
			(1)	(2)	(3)		
1	31112-ZB4-003	FAN, GENERATOR COOLING	1	-	-	-----	ESS,ESS/A
2	32510-ZB6-003	TERMINAL ASSY., EARTH	1	-	-	-----	ESS,ESS/A
3	32610-ZB7-000	CABLE, EARTH	1	-	-	-----	ESS,ESS/A
4	42710-ZB6-003	WHEEL COMP. (100X33)	2	-	-	1833854	ESS
	42710-ZS9-A01	WHEEL COMP. (100X32)	2	-	-	-----	ESS/A
			2	-	-	1833855	ESS
5	42715-ZB7-003	WHEEL COMP. (100X33)	2	-	-	1833854	ESS
	42710-ZS9-A01	WHEEL COMP. (100X32)	2	-	-	-----	ESS/A
			2	-	-	1833855	ESS
6	42721-ZB6-000	BRACKET, R. WHEEL	2	-	-	-----	ESS,ESS/A
7	42725-ZB6-000	BRACKET, L. WHEEL	2	-	-	-----	ESS,ESS/A
8	50310-ZB7-000ZD	FRAME COMP., UNDER *NH105*...MAT BLACK (#15-#20)	1	-	-	-----	ESS,ESS/A
9	68310-ZB7-000	GUIDE, UNDER AIR	1	-	-	-----	ESS,ESS/A
10	68312-ZB7-000	SEAL, UNDER AIR GUIDE	1	-	-	-----	ESS,ESS/A
11	68325-ZB4-000	RUBBER, BOTTOM	2	-	-	-----	ESS,ESS/A
12	68325-899-000	RUBBER, BOTTOM	2	-	-	-----	ESS,ESS/A
13	89011-192-700	BAND, TOOL SETTING	1	-	-	-----	ESS,ESS/A
14	90013-883-000	BOLT, FLANGE, 6X12(CT200)	1	-	-	-----	ESS,ESS/A
15	90032-875-003	SCREW, TAPPING, 5X14	3	-	-	-----	ESS,ESS/A
16	90381-812-710	NUT, SPECIAL, 6MM	2	-	-	-----	ESS,ESS/A
17	90855-ZB4-000	GROMMET, CRANKCASE	1	-	-	-----	ESS,ESS/A
18	91554-ZB6-000	COLLAR, WHEEL SHAFT	4	-	-	-----	ESS,ESS/A
19	94050-08000	NUT, FLANGE, 8MM	4	-	-	-----	ESS,ESS/A
20	94050-10000	NUT, FLANGE, 10MM	4	-	-	-----	ESS,ESS/A

2

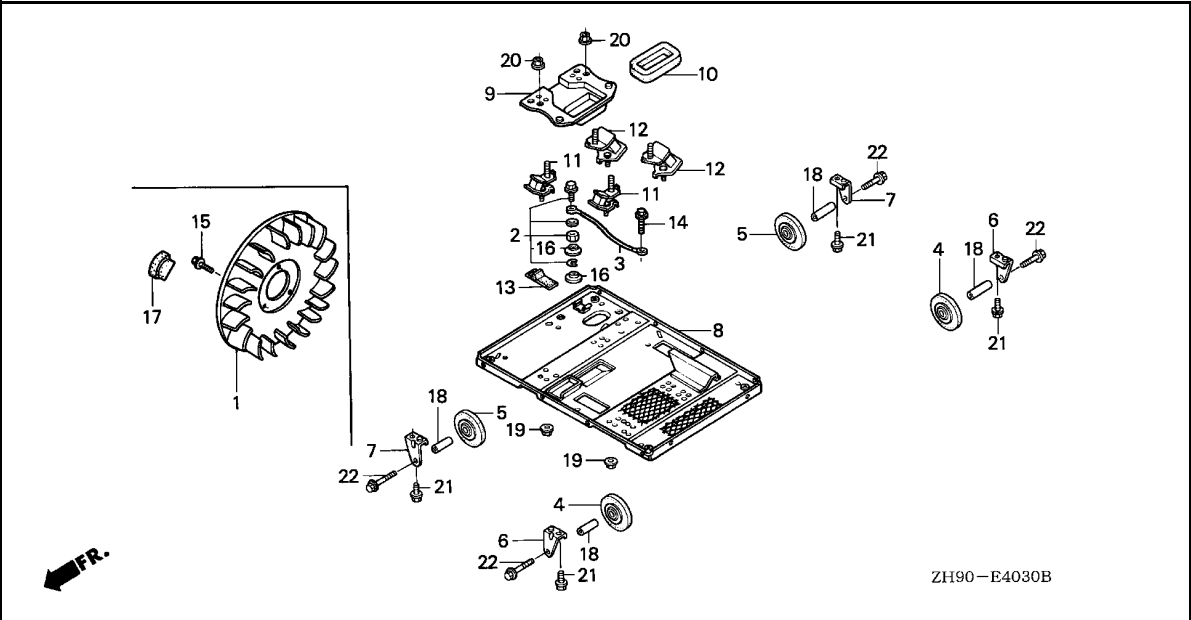

Ref. No.	Part No.	Description	Reqd. QTY			Serial No.	Parts catalogue code
			(1)	(2)	(3)		

21	95701-08016-00	BOLT, FLANGE, 8X16	4	-	-	-----	ESS,ESS/A
22	95723-08055-00	BOLT, FLANGE, 8X55	4	-	-	-----	ESS,ESS/A



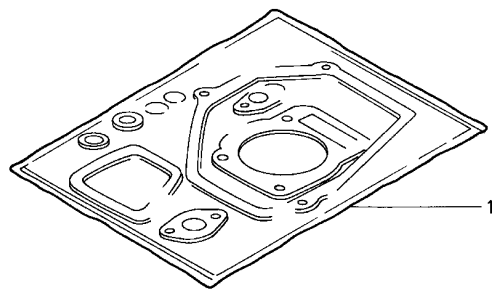

HENG-X0003

Ref. L.O.N. (Relative ref. Number) F.R.T.
No. Description

NO INFORMATION

Ref. No.	Part No.	Description	Reqd. QTY			Serial No.	Parts catalogue code
			(1)	(2)	(3)		
1	061A1-ZH9-000	GASKET KIT	1	-	-	1046250	HA,HH,HX,LH,LHE,LJ,LW,LWD,LX,LXZ,PA,PX,QA,QAE,QD,QE,QH,QHC,QHE,QP,QX,QXB,QXC,QXE,QXEB,RA,RD,RH,RHE,RX,SD,SE,SH,SHE,SHEZ,SJ,SK,SW,SWE,SX,SXB,SXE,SXEB,VA,VAW,VH,VNG1,VSD,VSD3,VX,VXB,VXE,VXEB
			1	-	-	1048121	HAQ,QAQ
			-	1	-	1046250	
	061A1-ZH9-050	1	1	-	1046251	HA,HH,LXZ,PA,QA,QAE,QHC,QHE,QXEB,Q2,RA,RH,RHE,SHE,SHEZ,SK,SW,SWE,VA,VAW,VH,VXE,V1
			1	1	-	1046251	1641019 HX,LH,LHE,LJ,LW,LWD,LX,L1,L1/A,PX,QD,QE,QH,QP,QX,QXB,QXE,Q1,Q1/A,RD,RX,R1,R1/A,SD,SE,SH,SJ,SX,SXB,SXE,SXEB,S1,S1/A,VNG1,VSD,VSD3,VX,VXB,VXEB,W1,W1/A
			1	-	-		HEA,LHB1,LHB3,LHQ4,LSS,LX16,QAB1,SMD,SX2,VAW1,VDE,VD16,VEB6,VWA,VW22,VXB2,VXB6,VXG,VX26
			1	-	-	1048122	HAQ,QAQ
			1	-	-	1187115	LTJ,QSC
			1	-	-	1641019	HA2,HEA2,HEA8,HXQ4,HX26,HX8,LJC,LJG,LXE,LXE8,LXQ4,LXU,PAE2,PA2,PXU,PX26,QAB3,QAE2,QAE6,QAQ4,QAR2,QA2,QHE4,QHP1,QHQ4,QHZ,QH26,QME2,QMH,QSC9,QXC4,QXC6,QXC9,QXE4,QXE6,QXE8,QXQ4,QXU,QX26,RA2,RHE4,RHQ4,RH26,RSC2,RXQ4,RXU,SHQ4,SJG,SMC4,SME1,SME6,SN,SXE4,SXE8,SXQ4,SXU,VA2,VDE2,VME2,VM2,VWA2,VWN2,VWT4,VW12,VXE4,VXQ4,VXU,VXU1,WMT8
			1	-	-	1046251	1187115 QXC
			-	-	1	1000186	VXP,VXQP
	06111-ZK9-S00	1	-	-	1641019	QWA2,VNT2
	06111-ZK9-S01	1	-	-		VNT2/A
			1	-	-	1641020	QWA2,VNT2

PART NO. INDEX

2-G 2

Part Number	Address	Page	Ref.	Part Number	Address	Page	Ref.	Part Number	Address	Page	Ref.	Part Number	Address	Page	Ref.	Part Number	Address	Page	Ref.
16124-ZE0-005	J2	127	11																
	K6	147	9	16268-ZE2-721	2-D6	243	2	G1	78	14	16731-ZE2-003	I2	111	3	17222-ZB4-000	L15	172	5	
	K10	151	9		K8	149	22	G3	80	13	16851-ZB7-700	2-B3	208	2	17222-ZB7-000	L16	173	6	
	K12	153	3	16269-ZA0-800	K8	149	23	G6	83	11	16852-ZB6-000	2-B2	207	1	17230-ZE2-820	L2	159	4	
16145-ZB7-700	2-F11	280	1		K11	152	22	G9	86	14	16854-ZB6-000	2-B2	207	2	17230-ZE3-841	L11	168	5	
16148-141-881	J2	127	12	16270-ZB4-000	2-D6	243	3	G11	88	8	16854-ZE1-000	N5	194	1	17231-899-000	L15	172	6	
	K7	148	10	16270-ZB4-010	2-D6	243	3	E14	59	3	16854-ZH8-000	N6	195	1	17231-ZB7-000	L16	173	7	
	K10	151	10	16271-ZB4-000	2-D6	243	4	16550-ZE2-700	2-D4	241	36	16857-ZB6-000	2-B2	207	3	17231-ZE2-000	K13	154	4
16166-ZE2-781	J2	127	13	16271-ZE2-000	K15	156	1	16551-ZE2-000	2-C5	226	1	16857-ZB7-000	2-B3	208	3	17231-ZE2-810	K15	156	3
16166-ZH9-000	J2	127	13		L1	158	1	16551-ZE2-780	2-D5	242	3	16910-GB2-005	N14	203	18	17231-ZH9-820	L3	160	5
16166-ZH9-820	J2	127	13		L11	168	1	16551-ZE2-780	2-C6	227	2		2-B2	207	3	17231-ZH9-N01	L13	170	4
	K7	148	11	16271-ZE2-010	L13	170	1	16555-ZE2-000	2-C6	227	2	16915-GB2-000	2-B2	207	5	17232-891-000	L4	161	6
	K10	151	11		K15	156	1	16555-ZE2-780	2-D5	242	4	16950-ZA0-803	2-B3	208	4		L11	168	6
16166-ZH9-W00	J2	127	13		L1	158	1	16559-ZE2-780	2-D5	242	5	16950-ZB4-015	2-B1	206	2		L13	170	5
16166-ZH9-W20	J3	128	13		L11	168	1	16561-ZE2-000	2-C7	228	3		2-F8	277	2	17233-896-701	M1	174	1
16172-ZE3-W10	K5	146	32	16273-ZB4-000	L13	170	1		2-C8	229	3	16952-ZB4-005	2-B1	206	3		M7	180	1
	K7	148	12	16325-ZB7-700	2-D6	243	5	16561-ZE2-800	2-D5	242	6		2-F8	277	3		N1	190	1
	K10	151	12	16400-ZE2-703	2-F11	280	2	16561-ZE2-A00	2-C8	229	3	16952-ZB6-000	2-B2	207	6	17235-899-000	L15	172	7
	K12	153	4	16500-ZE2-P52	K8	149	24	16561-ZE2-U30	2-F9	278	15	16952-ZB7-000	2-B3	208	5		L16	173	8
16173-001-004	J4	129	14	16510-ZE2-000	2-D5	242	2	16561-ZK9-800	2-C8	229	3	16953-ZE1-711	J8	133	20	17235-ZE2-820	L10	167	15
	2-B1	206	1		F8	69	9	16562-ZE2-000	2-C8	229	4	16953-ZE1-712	J8	133	20	17235-ZH9-N00	L13	170	6
	2-B3	208	1		F16	77	10		2-C8	229	4	16953-ZE1-811	J8	133	20	17235-ZH9-N01	L13	170	6
	2-F8	277	1		G3	80	9	16562-ZE2-700	2-D5	242	7	16953-ZE1-812	J8	133	20	17236-899-000	L15	172	8
16211-ZB7-000	K10	151	13	16510-ZE2-811	G11	88	4		2-C8	229	4	16954-ZE1-812	J9	134	21		L16	173	9
16211-ZE2-000	J4	129	15		F16	77	10	16570-ZE2-701	2-C9	230	8	16955-ZE1-000	N6	195	2	17238-ZE2-310	K13	154	5
	K9	150	53		G6	83	7	16570-ZE2-721	2-C9	230	9	16955-ZE2-H21	J9	134	22		K15	156	4
	K12	153	5	16510-ZE3-000	G9	86	10	16570-ZE2-W00	2-C8	229	5	16956-ZA7-000	2-F11	280	3		L4	161	7
16211-ZE2-700	K7	148	13		F15	76	23	16570-ZE2-W10	2-C8	229	6	16956-ZB7-700	2-B3	208	6		L11	168	7
16220-ZA0-702	J5	130	16	16511-ZE2-000	G8	85	20	16570-ZE2-W20	2-C9	230	7	16956-ZE1-811	J10	135	23		L14	171	7
	K12	153	6		F9	70	10	16570-ZE2-W40	2-C8	229	5	16957-ZB7-700	2-F11	280	4	17239-ZE1-000	K13	154	6
16221-ZA0-700	J5	130	17		G1	78	11	16570-ZE2-W50	2-C9	230	6	16957-ZE1-812	J10	135	24		K15	156	5
16221-ZA0-800	J6	131	17		G3	80	10	16571-ZE2-W00	2-C10	231	10	16958-397-771	2-B1	206	4		L5	162	8
	K7	148	14		G6	83	8	16571-ZE2-W10	2-C10	231	10		2-F8	277	4		L14	171	8
	K12	153	7		G9	86	11	16574-ZE1-000	2-C10	231	11	16958-ZB7-700	2-F11	280	5	17239-ZE3-840	L11	168	8
16221-ZB7-800	K10	151	14	16511-ZE8-000	G11	88	5	16575-ZE2-W00	2-C11	232	12	16959-471-831	2-B1	206	5	17252-899-000	L15	172	9
16223-ZA0-700	J6	131	18		F15	76	24	16576-891-000	2-C12	233	13		2-F8	277	5		L16	173	10
16223-ZA0-800	K7	148	15	16512-ZE2-000	G8	85	21				14	16960-ZB7-700	2-F11	280	6	17316-611-000	E4	49	10
	K10	151	15		F10	71	11	16578-ZE1-000	2-D5	242	8	16967-GA6-671	2-B1	206	6	17367-413-690	L15	172	10
	K12	153	8		G1	78	12	16581-ZE2-W00	2-C12	233	15		2-F8	277	6		L16	173	11
16230-ZE3-701	K9	150	49	16512-ZE2-811	G3	80	11	16584-883-300	2-C13	234	16	16967-MA2-771	2-B3	208	7	17402-ZE2-810	K15	156	6
	K10	151	16		G11	88	6		19	118	29	16967-ZE0-811	J11	136	25	17403-ZE2-810	K15	156	7
16252-ZA1-000	2-D6	243	1		G1	78	12		2-C14	235	17					17410-ZE2-020	K13	154	7
16252-ZA1-010	K10	151	17	16512-ZE3-000	G6	83	9	16590-ZE2-812	2-D5	242	9	17000					K15	156	8
	2-B6	243	1		G9	86	12	16591-ZE2-P51	2-C14	235	18	17210-ZE2-822	L2	159	2	17410-ZE3-840	L12	169	9
16260-ZB7-702	K10	151	18	16513-ZE2-000	F15	76	25	16592-732-700	K13	154	1	17210-ZE3-010	L11	168	2	17410-ZH9-N00	L14	171	9
16260-ZE2-722	K7	148	16		G8	85	22	16592-883-310	2-D5	242	10		L13	170	2	17420-ZE2-000	K13	154	8
16260-ZE2-730	K7	148	16		F10	71	12		2-C14	235	19	17211-899-000	L15	172	2		K15	156	9
16260-ZF6-U70	K9	150	54		G1	78	13	16594-883-010	2-D5	242	11		L16	173	3	17420-ZE2-P50	K13	154	8
16261-ZB7-700	K10	151	19		G3	80	12		2-C14	235	20	17211-ZE2-000	K13	154	2	17470-ZE3-841	L12	169	10
16261-ZE2-702	K7	148	17		G6	83	10	16599-ZG1-M10	2-D5	242	11	17212-ZB4-003	L15	172	3	17470-ZE3-842	L12	169	10
16262-ZE2-711	K7	148	18		G8	85	23	16610-ZE1-000	2-C15	236	22		L16	173	4	17475-ZE3-841	L12	169	11
16263-ZA0-000	K7	148	19	16531-Z0A-000	G9	86	13		J7	132	19	17212-ZE2-000	K13	154	3	17476-ZE3-841	L12	169	12
	2-D5	242	1		G11	88	7	16611-ZE2-711	K12	153	9	17212-ZE2-810	K15	156	2	17500-ZE2-811ZA	N6	195	3
16263-ZB7-701	K11	152	20		F11	72	13	16611-ZE3-D21	K8	149	25	17218-ZE2-821	L2	159	3	17500-ZE2-812ZA	N6	195	3
16264-ZE2-700	K7	148	20		G1	78	14	16613-893-000	K8	149	26	17218-ZE3-000	L11	168	3	17500-ZE2-813ZA	N6	195	3
16264-ZE2-701	K7	148	20		G3	80	13	16615-893-000	K8	149	27		L13	170	3	17505-898-023	2-B2	207	7
16265-ZE2-721	K8	149	21		G6	83	11	16615-ZE2-810	K8	149	27	17219-ZE3-840	L11	168	4	17505-ZB2-003	2-B1	206	7
16268-893-000	K11	152	21	16531-ZE2-000	G10	87	14	16617-890-010	2-C15	236	23	17220-ZB4-003	L15	172	4		2-B3	208	8
					G11	88	8	16674-ZE2-P50	G11	88	8	17220-ZB7-000	L16	173	5		2-F8	277	7
					F10	71	13		2-D5	242	12								

PART NO. INDEX

Part Number	Address	Page	Ref.	Part Number	Address	Page	Ref.	Part Number	Address	Page	Ref.	Part Number	Address	Page	Ref.				
31610-ZE2-842ZB	2-D9	246	2	32127-738-700	2-D7	244	6	36170-ZB4-003	K9	150	55	81000							
31610-ZE2-852ZB	2-D9	246	2		2-D12	249	7	36180-ZV3-003	2-F9	278	3		87528-ZE2-810	2-E14	267	10			
31610-ZE2-853ZA	2-D9	246	2		2-F9	278	2	36180-ZV5-013	2-F10	279	21	81329-567-020	18	117	16				
31610-ZE2-853ZB	2-D10	247	2	32197-ZE1-003	2-D12	249	8	36182-ZV4-650	2-F9	278	4		87528-ZF6-W40	2-E14	267	10			
31610-ZE2-853ZD	2-D9	246	2		2-E2	255	7					83000	87528-ZH7-000	2-F10	279	19			
31610-ZE2-854ZA	2-D10	247	2	32197-ZE2-003	E14	59	4	38000					87529-ZE2-010	2-D8	245	13			
31610-ZE2-854ZB	2-D10	247	2	32197-ZH8-003	I6	115	10					83501-ZF1-000	2-F5	274	1				
31610-ZE2-854ZD	2-D10	247	2	32343-892-003	2-F11	280	10	38240-VA3-900	2-D8	245	11		87529-ZE2-020	2-D8	245	13			
31610-ZE2-854ZF	2-D10	247	2	32510-ZB6-003	2-F13	282	2		2-D13	250	13	87000		2-D14	251	15			
31610-ZE2-862ZB	2-D9	246	2	32610-ZB7-000	2-F13	282	3	38240-ZE2-840	2-D14	251	13		87529-ZE2-811	2-D8	245	13			
31610-ZE2-862ZD	2-D10	247	2	32902-892-003	2-D7	244	7	38250-ZA8-701	2-D8	245	12	87106-737-J00	2-F4	273	13				
31610-ZE2-872ZB	2-D9	246	2		2-D12	249	9		2-D14	251	14	87106-ZE9-V00	2-F1	270	29				
31610-ZE2-873ZB	2-D10	247	2		2-E2	255	8	42000				87114-ZH7-000	2-F2	271	31				
31610-ZE2-874ZB	2-D10	247	2		2-F11	280	11					87124-ZV3-010	2-E11	264	2				
31610-ZE2-874ZD	2-D11	248	2					42710-ZB6-003	2-F13	282	4	87135-ZE2-000	2-F1	270	27				
31610-ZE2-W01ZC	2-E2	255	1	34000				42710-ZS9-A01	2-F13	282	4		87529-ZE2-831	2-D14	251	15			
31610-ZE2-W02ZC	2-E2	255	1										87529-ZE2-860	2-D14	251	15			
31610-ZE2-W02ZE	2-E2	255	1	34150-ZH7-003	F2	63	16							2-E2	255	11			
31610-ZH9-W51ZA	2-D9	246	2		2-E1	254	26	42715-ZB7-003	2-F13	282	5	87135-ZE2-010	2-F1	270	27				
31610-ZH9-W52ZA	2-D10	247	2		2-E3	256	17	42721-ZB6-000	2-F13	282	6		87529-ZE2-870	2-D14	251	15			
31610-ZH9-W52ZB	2-D9	246	2					42725-ZB6-000	2-F13	282	7		87529-ZH8-W40	2-D14	251	15			
31610-ZH9-W52ZC	2-D10	247	2	35000								87135-ZE2-020	2-F1	270	28				
31610-ZK2-W41ZA	2-D10	247	2					50000					2-F2	271	30				
31610-ZK9-W41ZA	2-D10	247	2	35100-768-S01	2-F9	278	12						2-F4	273	16				
31610-ZK9-W42ZA	2-D10	247	2	35100-ZE2-023	2-D8	245	8	50310-ZB7-000ZD	2-F13	282	8	87150-ZH8-000	2-F4	273	14				
31610-ZK9-W42ZC	2-D10	247	2		2-D12	249	10	50317-254-000	19	118	26	87511-892-000	2-F9	278	7				
31612-ZE2-003	2-D7	244	2	35100-ZE2-842	2-D12	249	10	50319-ZB2-000	2-F8	277	12	87520-ZH8-000	2-F3	272	1				
	2-D11	248	3	35100-ZE2-862	2-D13	250	10					87521-ZH9-000	2-F3	272	2				
	2-E2	255	2	35100-ZE2-W01	2-E2	255	9	53000				87521-ZH9-010	2-E11	264	3				
31614-ZE2-003	2-D7	244	3	35110-736-612	2-F9	278	13						2-F3	272	2				
	2-D11	248	4	35110-766-003	2-F9	278	13	53149-964-003	K8	149	29	87521-ZH9-020	2-E12	265	3				
	2-E2	255	3	35111-880-003	2-D8	245	9						2-F3	272	2				
31615-ZE2-003ZA	2-D11	248	5		2-D13	250	11	63000				87521-ZH9-030	2-E12	265	3				
31615-ZE2-003ZB	2-D7	244	4		2-E2	255	10					87521-ZH9-810	2-E11	264	3				
	2-D12	249	5	35111-880-013	2-D8	245	9	63117-ZB7-700	2-F11	280	15	87522-892-000	2-F9	278	8				
	2-E2	255	4		2-D13	250	11	63140-ZB7-700ZA	2-F11	280	16	87522-ZE1-010	2-F3	272	3				
31615-ZE2-003ZE	2-D12	249	5					63140-ZB7-700ZB	2-F11	280	16	87522-ZE1-810	2-E12	265	4				
31615-ZE2-003ZG	2-D7	244	4	36000									2-F3	272	3				
	2-D12	249	5					64000				87522-ZH8-W40	2-E12	265	5				
	2-E2	255	4	36100-ZB7-701	2-F11	280	12						2-E13	266	6				
31620-762-003	2-F9	278	11	36100-ZE1-015	I6	115	11	64181-ZB7-000	N4	193	10	87522-ZH8-W41	2-E13	266	5				
31620-ZG5-003	2-E2	255	5	36100-ZF6-P81	I7	116	11	64182-ZB7-000	N4	193	11			6	87532-ZH9-V00	2-E15	268	15	
31620-ZG5-013	2-D8	245	24	36100-ZH7-003	I7	116	11	64185-ZB7-000	N4	193	12			6	87532-ZH9-W40	2-E16	269	19	
	2-E2	255	5	36100-ZH7-W41	I7	116	11	64186-ZB7-000	N4	193	13	87522-ZH9-000	2-F9	278	17	87532-ZH9-W41	2-E16	269	19
31630-ZE1-003	2-B10	215	9	36100-ZH8-W41	I7	116	11						2-E13	266	7	87533-ZA7-650	2-E16	269	20
31630-ZE2-841	2-B10	215	9	36100-ZH9-V01	I1	110	2	68000				87522-ZH9-010	2-E14	267	8	87533-ZB6-000	2-F9	278	10
31630-ZE2-861	2-B12	217	19	36100-ZH9-V02	I1	110	2							8	87533-ZC0-630	2-E16	269	25	
31630-ZE2-W01	2-B11	216	17	36101-ZE1-010	2-B10	215	10	68310-ZB7-000	2-F13	282	9			8	87534-892-640	2-F9	278	14	
31700-124-008	2-D7	244	5	36101-ZE2-701	2-B10	215	10	68312-ZB7-000	2-F13	282	10	87522-ZH9-820	2-E13	266	7	87534-ZE1-841	2-E16	269	21
	2-D12	249	6	36103-ZE1-000	I8	117	12	68325-899-000	2-F6	275	19	87522-ZH9-821	2-E14	267	7	87535-ZE1-840	2-E16	269	22
	2-F9	278	1		2-B10	215	11		2-F13	282	12	87524-883-690	2-E14	267	9	87535-ZE1-841	2-E16	269	22
32000					2-D8	245	10	68325-ZB4-000	2-F6	275	18	87526-ZH8-000	2-F3	272	4	87539-737-J00	2-F4	273	15
					2-D13	250	12		2-F13	282	11	87528-883-661	2-E14	267	11	87539-898-620	2-E16	269	26
					2-F11	280	13					87528-898-620	2-E14	267	12	87539-ZB2-000	2-F9	278	5
32100-ZB7-700	2-F11	280	9	36106-892-003	2-F11	280	13	76000					2-F9	278	16	87561-733-J00	2-F4	273	12
32110-ZE2-860	2-E1	254	29	36135-PH3-004	K12	153	10					87528-ZB7-700	2-F9	278	9	87565-ZB4-A00	2-F4	273	11
32110-ZE2-W00	2-D8	245	25	36135-ZF6-D41	K8	149	28					87528-ZB7-701	2-F9	278	9		2-F8	277	13
	2-E2	255	6	36135-ZV1-003	K8	149	28	76122-952-000	2-B1	206	18			8	87528-ZE1-690	2-E14	267	10	
	2-B3	208	14	36160-ZB4-003	2-D6	243	6					87528-ZE2-000	2-F3	272	5	87565-ZE2-810	2-E16	269	23

PART NO. INDEX

2-G 5

Part Number	Address	Page	Ref.	Part Number	Address	Page	Ref.	Part Number	Address	Page	Ref.	Part Number	Address	Page	Ref.	Part Number	Address	Page	Ref.
87565-ZE2-A01	2-E16	269	23		2-D14	251	16		L12	169	15		G7	84	12	91202-805-610	2-E6	259	22
	2-F4	273	11		2-F11	280	17		L14	171	11		G10	87	16	91301-805-000	F15	76	22
87594-ZB4-A00	2-E16	269	24		2-F13	282	14	90203-ZA0-800	K14	155	10		G11	88	9		G11	88	12
	2-F4	273	17	90014-ZE2-000	E4	49	11		K16	157	11	90605-230-000	2-D2	239	28		2-E6	259	23
88000				90015-883-000	2-B11	216	13		L6	163	11			29		91353-671-004	E15	60	10
									L12	169	15	90624-SB0-003	L16	173	12		N10	199	12
88911-MJ3-000	K8	149	30		2-B12	217	21		L14	171	11	90630-751-000	F3	64	18	91406-ZE2-003	2-D8	245	18
								90206-ZE1-000	H3	96	15		I8	117	21		2-D16	253	20
89000								90301-ZV0-000	K14	155	10		2-D8	245	16	91502-ZB4-701	2-D6	243	8
				90015-ZE5-010	2-D1	238	25	90302-921-000	2-F9	278	6		2-D15	252	18	91502-ZB7-700	K11	152	24
89000-ZB6-000	2-F7	276	12		2-D5	242	14	90302-KF9-900	M6	179	23	90650-SB9-003	K9	150	50	91551-898-000	2-B1	206	14
89000-ZE1-000	2-F5	274	2	90016-ZG9-N30	2-D2	239	26		M12	185	23		2-F12	281	24		2-F8	277	16
	2-F7	276	1	90017-883-000	2-B11	216	14		N2	191	16	90654-SA4-003	I9	118	27	91551-ZB7-000	N4	193	14
	2-F5	274	3		2-B12	217	20	90310-ZB7-701	2-F11	280	19	90672-SA0-003	2-D8	245	17	91552-ZT1-000	N3	192	8
89001-ZF1-000	2-F5	274	3					90325-044-000	K14	155	11		2-D15	252	19	91554-ZB6-000	2-F13	282	18
89011-192-700	2-F13	282	13	90018-ZK6-P10	E6	51	13		K16	157	12	90683-SA0-003	2-F12	281	25	91601-ZE2-003	2-C2	223	21
89102-538-000	2-F5	274	4	90019-883-000	G11	88	17		L7	164	12	90684-ZA0-601	I9	118	22				
89103-538-000	2-F5	274	5		I8	117	20		L8	165	12		2-B12	217	18	92000			
89210-ZF1-000	2-F5	274	6	90032-875-003	2-F13	282	15		L12	169	16	90691-ZB7-003	2-F12	281	26				
89216-809-000	2-F7	276	2	90042-ZB7-000	E4	49	12		L14	171	12	90700-ZB7-000	2-F12	281	27	92000-08025-0A	G14	91	9
89216-ZB4-000	2-F6	275	20	90042-ZE2-000	E5	50	12	90380-MA6-010	2-D8	245	15	90701-HC4-000	F12	73	16		2-E8	261	10
89216-ZF1-000	2-F5	274	7	90042-ZE2-700	E5	50	12		2-D15	252	17		G1	78	17	92100-08035-0H	2-E6	259	24
89218-ZE1-000	2-F6	275	8	90045-PD1-000	2-F11	280	18		2-E3	256	12		G7	84	13	92101-08025-0A	G14	91	9
	2-F7	276	3	90047-ZE2-000	E6	51	13	90381-812-710	2-F13	282	16		G10	87	17		2-E8	261	10
89219-805-000	2-F6	275	9	90047-ZE3-791	E6	51	13	90401-ZE2-620	2-E9	262	6		G11	88	10	92101-08028-0A	N4	193	15
	2-F7	276	4	90050-ZE1-000	M5	178	19	90402-ZE2-620	2-E9	262	7	90741-805-000	G14	91	12	92101-08035-0A	2-E6	259	24
89220-ZE2-000	2-F6	275	10					90403-889-000	2-E6	259	18		2-E6	259	19	92101-08035-0H	2-E6	259	24
								90403-ZH9-003	2-C2	223	20		2-E7	260	8	92301-05016-0A	2-D5	242	15
90000					M6	179	29	90431-ZE2-700	K8	149	31	90741-889-000	2-E6	259	20	92800-12000	F3	64	20
					M11	184	19	90432-ZE2-700	K8	149	32	90741-889-810	G14	91	12		2-E6	259	25
90001-ZE8-000	G16	93	5		M12	185	20	90433-ZE2-700	K8	149	33		2-E6	259	19	92900-08032-0E	E6	51	13
90002-ZE2-U91	N2	191	15		M14	187	31		2-F11	280	20		2-E8	261	8				
90003-ZE2-000	G14	91	9		M16	189	9	90434-ZB7-700	2-F11	280	21	90741-ZE2-000	2-B6	211	9	93000			
90003-ZE3-600	G14	91	9					90434-ZE2-700	K8	149	34	90745-ZE2-600	G14	91	12				
90004-ZE2-W01	H15	108	13	90050-ZE3-H00	M16	189	9	90441-ZE2-010	E6	51	14		2-E9	262	9	93404-06020-08	K14	155	13
90006-ZE2-000	M12	185	26	90050-ZH8-W40	M5	178	21	90446-KE1-000	E14	59	7	90745-ZE2-G00	2-E9	262	9		K16	157	13
90007-ZE2-003	2-C3	224	22		M12	185	21	90471-ZE3-000	2-E7	260	7	90745-ZK2-800	2-E8	261	8		L8	165	13
90008-ZE2-003	H16	109	14		N2	191	14	90473-147-000	F12	73	14	90755-758-L00	2-F6	275	11		L12	169	17
	I9	118	25	90055-ZE1-000	M6	179	22		G1	78	15	90801-ZE2-003	E14	59	8		L14	171	13
									G3	80	14	90851-898-000	2-B1	206	12	93494-06020-08	K14	155	13
90009-ZE2-003	K14	155	13						G8	85	19		2-F8	277	14		K16	157	13
	K16	157	13		M12	185	22					90854-ZB2-000	2-B1	206	13		L8	165	13
	L8	165	13		M14	187	31						2-F8	277	15		L12	169	17
	L12	169	17		M16	189	10		G10	87	15		2-F8	277	15		L14	171	13
	L14	171	13	90110-ZE2-003	2-C2	223	19	90473-842-000	G11	88	18	90854-ZB3-000	N14	203	19		L14	171	13
90012-KM9-000	E6	51	13	90114-SA0-000	2-D2	239	27		2-E7	260	6	90855-ZB4-000	2-F6	275	22	93500-03006-1H	J12	137	26
90012-ZE0-010	H3	96	14	90131-883-000	E14	59	6	90473-ZE2-000	2-E9	262	8		2-F13	282	17	93500-03008-0A	2-F12	281	28
90013-883-000	E14	59	5	90131-ZE3-790	F3	64	19	90503-898-000	2-B1	206	11	90899-422-610	K14	155	12	93500-03008-1G	J12	137	26
	F3	64	17	90142-MB0-000	L12	169	13	90511-735-801	2-F11	280	22					93500-03012-0H	2-D8	245	19
	I8	117	17	90201-415-000	K13	154	9	90523-GB6-920	2-F11	280	23	91000				93500-04006-0H	2-D16	253	21
								90534-706-010	G14	91	11						2-D2	239	30
									2-E7	260	7	91001-ZH9-003	G14	91	13				
												91201-889-003	F12	73	17	93500-04008-0A	K11	152	25
												91201-890-003	E14	59	9	93500-04012-0H	2-D8	245	20
													F13	74	17		2-D16	253	22
				90201-ZE3-790	2-B6	211	8		G7	84	12		G7	84	14		2-E3	256	13
				90201-ZE3-V00	2-B6	211	8		G10	87	16		G11	88	11	93500-05008-0A	I9	118	23
				90203-PB2-000	K13	154	10	90602-ZE1-000	F12	73	15		2-E6	259	21		2-D6	243	9
					K16	157	11		G1	78	16		2-E8	261	9	93500-05012-0A	K8	149	35
					L6	163	11		G3	80	15		2-E9	262	10	93500-05016-0A	2-D4	241	33



PART NO. INDEX

2-G 6

Part Number	Address	Page	Ref.	Part Number	Address	Page	Ref.	Part Number	Address	Page	Ref.	Part Number	Address	Page	Ref.
93500-05025-OH	2-D5	242	16		G10	87	18	95005-35040-10	K8	149	42	96100-62050-00	2-E6	259	31
93500-05028-OA	2-D3	240	32		G11	88	13	95005-35055-10	K8	149	42	96100-62060-00	F14	75	20
93500-05032-OA	I9	118	24	94103-05000	K8	149	37	95005-35065-10	K8	149	42		G2	79	22
93500-05035-OA	2-D4	241	37	94103-05700	M6	179	27	95005-35075-10	K8	149	43		G4	81	20
93500-05035-OH	2-D5	242	17		M13	186	28	95005-35085-10	2-F12	281	31		G8	85	18
93600-05010-OA	N10	199	13		N2	191	20	95005-35130-10	K8	149	43		G10	87	22
	2-B1	206	15	94109-12000	E16	61	12	95005-35175-10	2-F12	281	32		G11	88	15
	2-B3	208	15		2-E6	259	26	95700-06050-08	2-E6	259	29		2-E6	259	32
	2-F8	277	17	94111-04800	2-D8	245	22	95700-08032-08	2-E6	259	30		2-E8	261	14
93891-05012-00	M6	179	24		2-D16	253	24	95701-06008-00	H16	109	14		2-E10	263	14
	M12	185	24		2-E3	256	15		I9	118	28	96100-63020-00	G4	81	21
	N2	191	17	94111-05000	M6	179	28	95701-06010-00	2-F6	275	23		G10	87	23
93891-06020-07	M6	179	25		M14	187	29	95701-06012-00	F2	63	14		2-E10	263	15
	M12	185	25				30		N4	193	17				
	N2	191	18		N2	191	21	95701-06035-08	K14	155	13	98000			
93892-05012-18	K9	150	51	94111-05800	2-D5	242	19	95701-06050-08	2-E6	259	29				
	K11	152	26	94111-08800	2-E6	259	27	95701-08016-00	N2	191	22	98079-55841	E6	51	17
93892-05014-18	2-C2	223	22	94201-20180	2-F12	281	30		N4	193	18	98079-55846	E7	52	17
93892-05032-18	2-C3	224	23	94251-08000	E16	61	13		2-F14	283	21		2-F6	275	21
93893-05016-00	2-D4	241	33	94251-10000	F1	62	13	95701-08016-08	N2	191	22	98079-55854	E8	53	17
			34		F2	63	13	95701-08020-00	N2	191	23	98079-55855	E8	53	17
93901-360J0	M12	185	26	94252-08000	2-F6	275	12	95701-08020-08	N2	191	23	98079-56841	E8	53	17
				94301-08140	G3	80	17	95701-08025-00	N14	203	17		2-F6	275	21
94000					2-E6	259	28		2-E8	261	10	98079-56846	E9	54	17
					2-E8	261	11				12	98079-56854	E10	55	17
94001-04390-0S	2-D8	245	21		2-E9	262	11		2-E9	262	12	98079-56855	E10	55	17
	2-D16	253	23	94301-12200	E6	51	15	95701-08032-08	2-E6	259	30	98200-30500	2-D8	245	23
	2-E3	256	14	94305-20062	2-D6	243	10	95701-08035-00	F14	75	19		2-D16	253	25
94001-08000-0S	N4	193	16	94305-20122	J13	138	27		G2	79	19	98200-31500	2-D16	253	25
94050-05000	L15	172	11		K12	153	11		G4	81	18	98200-32500	2-E3	256	16
	L16	173	13	94540-02010	K8	149	38		G8	85	16				
94050-06000	K14	155	14	94540-04010	K8	149	39		G10	87	19	99000			
	K16	157	14	94540-04018	K11	152	27		G11	88	14				
	L9	166	14		2-D6	243	11	95701-08040-00	N4	193	19	99001-10120	2-F6	275	13
	L12	169	18	94540-05010	K11	152	28		2-C4	225	25		2-F7	276	8
	L14	171	14	94540-07010	K8	149	40		2-E8	261	13	99001-10140	2-F6	275	14
	L15	172	13						2-E10	263	13	99001-14170	2-F6	275	15
	L16	173	14	95000				95723-08055-00	2-F14	283	22		2-F7	276	9
	2-B3	208	16					95725-10080-00	E6	51	16	99003-30000	2-F7	276	13
	2-D4	241	35	95001-45120-40	N14	203	20	95900-08025-00	N14	203	17	99003-50000	2-F7	276	14
	2-D5	242	18	95001-45150-40	N14	203	21		2-E8	261	12	99004-21003	2-F6	275	16
	2-F12	281	29		2-B1	206	16	95900-08035-00	2-E9	262	12		2-F7	276	10
94050-06080	L15	172	12	95001-45222-40	N12	201	15		F14	75	19	99005-01000	2-F7	276	15
94050-08000	M6	179	26	95001-45250-40	2-B3	208	17		G2	79	19	99008-02000	2-F7	276	11
	M13	186	27		2-F8	277	18		G4	81	18	99008-02300	2-F6	275	17
	M16	189	11	95001-45430-40	N12	201	15		G8	85	16		2-F7	276	11
	N2	191	19	95002-02070	K8	149	41		G10	87	19	99101-ZF5-0820	J14	139	28
	N3	192	9	95002-02080	N13	202	16	95900-08040-00	2-E8	261	13		J15	140	28
	N11	200	14		2-B1	206	17		2-E10	263	13	99101-ZF5-0850	J14	139	28
	2-F13	282	19		2-B2	207	15						J15	140	28
94050-10000	E16	61	11		2-B3	208	18	96000				99101-ZF5-0880	J14	139	28
	2-F13	282	20		2-F8	277	19						J15	140	28
94070-06080	2-C4	225	24	95002-02100	2-B2	207	16	96100-62020-00	F2	63	15	99101-ZF5-0900	J14	139	28
94101-04800	2-E1	254	27		2-B3	208	19		G2	79	20		J15	140	28
	2-E3	256	18	95002-45000	L16	173	15		G8	85	17	99101-ZF5-0920	J14	139	28
94101-06800	F14	75	18	95003-09023-31	L16	173	16		G10	87	20		J15	140	28
	G1	78	18	95003-09038-31	L16	173	17	96100-62040-00	G2	79	21	99101-ZF5-0950	J14	139	28
	G3	80	16	95005-11100-30	E4	49	7		G4	81	19		J15	140	28
	G8	85	15	95005-11105-30	E3	48	7		G10	87	21	99101-ZH7-0800	J14	139	28

PART NAME INDEX

Part name	Address	Page	Ref.	Part name	Address	Page	Ref.	Part name	Address	Page	Ref.
[A]				BEARING, RADIAL BALL, 6302	G10	87	23	BOLT, FLANGE, 8X25	2-E8	261	12
ALERT UNIT, OIL	F2	63	16		2-E10	263	15		2-E9	262	12
	I1	110	2	BOLT-WASHER, 5X14	2-C3	224	22	BOLT, FLANGE, 8X32	2-E6	259	30
	2-D9	246	1	BOLT-WASHER, 6X20	K14	155	13	BOLT, FLANGE, 8X35	F14	75	19
	2-E1	254	26		K16	157	13		G2	79	19
	2-E3	256	17		L8	165	13		G4	81	18
ARMATURE COMP.	2-B16	221	11		L12	169	17		G8	85	16
ARM COMP., COCK CONTROL	2-F11	280	4	BOLT-WASHER, 6X22	L14	171	13		G10	87	19
ARM COMP., GOVERNOR	2-D4	241	36		K14	155	13	BOLT, FLANGE, 8X40	G11	88	14
ARM, GOVERNOR	2-C5	226	1		K16	157	13		N4	193	19
	2-D5	242	3		L8	165	13		2-C4	225	25
ARM, VALVE ROCKER	H2	95	3		L12	169	17		2-E8	261	13
ARRESTER, SPARK	M3	176	8	BOLT, CONNECTING ROD	L14	171	13		2-E10	263	13
	M9	182	8		G16	93	5	BOLT, FLANGE, 8X55	2-F14	283	22
	M15	188	7	BOLT, DRAIN PLUG, 12MM	F3	64	20	BOLT, GOVERNOR ARM	2-D1	238	25
	N1	190	6		2-E6	259	25		2-D5	242	14
AUTO-THROTTLE ASSY.	2-D6	243	3	BOLT, DRAIN PLUG, 12X15	E14	59	6	BOLT, HEAD COVER	E4	49	11
[B]				BOLT, FLANGE, 10X80	E6	51	16	BOLT, HEX.	G14	91	9
BAG SET, TOOL	2-F5	274	3	BOLT, FLANGE, 5X10	G11	88	17	BOLT, HEX., 3/8-24UNF	G14	91	9
BAG, TOOL, 200MM	2-F7	276	11		I8	117	20	BOLT, HEX., 8X25	G14	91	9
BAG, TOOL, 230MM	2-F6	275	17	BOLT, FLANGE, 6X10	H16	109	14		2-E8	261	10
	2-F7	276	11		I9	118	25	BOLT, HEX., 8X28	N4	193	15
BAND	2-D7	244	7		2-F6	275	23	BOLT, HEX., 8X35	2-E6	259	24
	2-D12	249	9	BOLT, FLANGE, 6X12	E14	59	5	BOLT, PIVOT, 8MM	H3	96	14
	2-E2	255	8		F2	63	14	BOLT, RECESSED, 5X16	2-D5	242	15
	2-F11	280	11		F3	64	17	BOLT, SPECIAL	2-F11	280	18
BAND, TOOL SETTING	2-F13	282	13		I8	117	17	BOLT, STUD, 8X111	E4	49	12
BARREL ASSY., CYLINDER	E11	56	1		18	117	18	BOLT, STUD, 8X123	E5	50	12
	E12	57	1		M4	177	18	BOLT, STUD, 8X22	E6	51	13
	E13	58	1		M11	184	18	BOLT, STUD, 8X32	E6	51	13
	E14	59	1		N4	193	17	BOLT, STUD, 8X34	E6	51	13
BAR A, HANDLE	2-F7	276	15		2-B11	216	12	BOLT, STUD, 8X40	E6	51	13
BASE COMP., CONTROL	2-C13	234	16		2-C16	237	24	BOLT, STUD, 8X47	E6	51	13
BASE COMP., MUFFLER COVER	M4	177	14		2-D5	242	13	BOLT, STUD, 8X98	E5	50	12
	M10	183	14		2-D6	243	7	BOX ASSY., CONTROL	2-D7	244	1
	N1	190	9		2-D8	245	14		2-D9	246	2
BASE, CORD CLIP	2-F12	281	27		2-D14	251	16		2-D10	247	2
BEARING, RADIAL BALL	G14	91	13		2-F11	280	17		2-D11	248	2
BEARING, RADIAL BALL, 6202 ...	F2	63	15		2-F13	282	14		2-E2	255	1
	G2	79	20	BOLT, FLANGE, 6X28	2-B11	216	13	BOX, TOOL	2-F5	274	1
	G8	85	17					BRACKET, CASE MOUNTING	2-D7	244	3
	G10	87	20		2-B12	217	14		2-D11	248	4
BEARING, RADIAL BALL, 6204 ...	G2	79	21						2-E2	255	3
	G4	81	19					BRACKET, CENTER	2-B14	219	6
	G10	87	21	BOLT, FLANGE, 6X32	2-B11	216	14	BRACKET, FR.	2-B14	219	7
	2-E6	259	31		2-B12	217	20	BRACKET, FUEL COCK	2-B3	208	6
BEARING, RADIAL BALL, 6205 ...	F14	75	20					BRACKET, L. WHEEL	2-F13	282	7
BEARING, RADIAL BALL, 6206 ...	G2	79	22					BRACKET, R. WHEEL	2-F13	282	6
	G4	81	20	BOLT, FLANGE, 6X35	K14	155	13	BUSH	2-B15	220	9
	G8	85	18	BOLT, FLANGE, 6X50	2-E6	259	29	BUSH, ARM PIVOT	K8	149	29
	G10	87	22	BOLT, FLANGE, 6X8	H16	109	14	BUSH, AUTO-THROTTLE LEVER	2-D6	243	8
	G11	88	15		I9	118	28	BUSH, CHOKE LEVER	K11	152	24
	2-E6	259	32		2-F14	283	21	BUSH, COCK CONTROL ARM	2-F11	280	6
	2-E8	261	14	BOLT, FLANGE, 8X16	N2	191	22	BUSH, CONTROL KNOB	2-F11	280	13
	2-E10	263	14		N4	193	18	BUSH, FUEL PURGE	2-B2	207	6
BEARING, RADIAL BALL, 6302 ...	G4	81	21		2-F14	283	21				
				BOLT, FLANGE, 8X20	N2	191	23	[C]			
				BOLT, FLANGE, 8X25	N14	203	17	CABLE COMP., CHOKE	2-F11	280	7
					2-E8	261	10				



PART NAME INDEX

2-H 2

Part name	Address	Page	Ref.	Part name	Address	Page	Ref.	Part name	Address	Page	Ref.
CABLE, EARTH	2-F13	282	3	CASE, CONTROL	2-E2	255	2	COIL ASSY., CHARGE	2-B10	215	9
CAMSHAFT ASSY.	H1	94	1	CASE, RECOIL GRIP	2-F11	280	16		2-B11	216	17
	H2	95	1	CASE, REDUCTION	2-E4	257	1		2-B12	217	19
CAP ASSY., NOISE SUPPRESSOR ..	2-B7	212	3	CENTER, CLUTCH	2-E4	257	4	COIL ASSY., IGNITION	2-B7	212	1
	2-B8	213	4	CENTER, CLUTCH WEIGHT	2-E5	258	12	COIL ASSY., LAMP	2-B8	213	5
CAP ASSY., OIL FILLER	F6	67	4	CHAIN, DRIVE	2-E5	258	14				
	F7	68	6	CHAIN, P.T.O. DRIVE	2-E7	260	3	COLLAR B, AIR CLEANER	K13	154	6
	F16	77	4	CHAMBER SET, FLOAT	I12	121	4		K15	156	5
			5		I13	122	5		L5	162	8
	G2	79	24		K6	147	4		L11	168	8
			25		K9	150	46		L14	171	8
	G3	80	4		K10	151	4	COLLAR, 6.9X9	N3	192	8
			5	CHOKE SET	I15	124	9	COLLAR, AIR CLEANER	K13	154	5
	G6	83	4		K12	153	1		K15	156	4
			5	CIRCLIP, 5MM	2-D2	239	28		L4	161	7
	G9	86	4				29		L11	168	7
			5	CLAMPER, CORD	2-B8	213	7		L14	171	7
CAP COMP., AIR CLEANER	K13	154	8		2-B11	216	15	COLLAR, AIR CLEANER CASE	M1	174	1
	K15	156	9	CLIP A, AIR CLEANER WIRE	L15	172	7		M7	180	1
CAP COMP., FUEL FILLER	N8	197	6		L16	173	8		N1	190	1
			7	CLIP B, AIR CLEANER WIRE	L15	172	8	COLLAR, CLUTCH STOP	2-B14	219	3
	N9	198	7		L16	173	9	COLLAR, GOVERNOR ROD	2-D5	242	5
	N16	205	23	CLIP, BREATHER TUBE	E4	49	10	COLLAR, LEVER	K8	149	34
	2-B1	206	8		L16	173	2	COLLAR, MUFFLER STAY	N4	193	14
	2-B2	207	11	CLIP, GOVERNOR HOLDER	F12	73	15	COLLAR, PUSH ROD	2-F11	280	21
	2-B3	208	11		G1	78	16	COLLAR, SETTING	K5	146	32
	2-F8	277	9		G3	80	15		K7	148	12
CAP, CHOKE DUST	J2	127	12		G7	84	12		K10	151	12
	K7	148	10		G10	87	16		K12	153	4
	K10	151	10		G11	88	9	COLLAR, STOPPER	2-C15	236	22
CAP, CHOKE LEVER	K10	151	17	CLIP, HARNESS	I9	118	22	COLLAR, TANK CUSHION	2-B1	206	14
	2-D6	243	1		2-B12	217	18		2-F8	277	16
CAP, FUEL METER	2-B2	207	8		2-F12	281	26	COLLAR, WHEEL SHAFT	2-F13	282	18
CAP, LEVER	J9	134	22	CLIP, HIGH TENSION CORD	I6	115	9	CONTACTOR ASSY.	2-B14	219	4
CAP, MUFFLER	M2	175	6	CLIP, PISTON PIN, 18MM	G16	93	6	CONTROL ASSY.	2-C8	229	5
	M8	181	6	CLIP, PURSE LOCK	F3	64	18				
	M15	188	5		I8	117	21		2-C9	230	6
CAP, OIL FILLER	F6	67	5		2-D8	245	16				
	F15	76	21		2-D15	252	18				
	F16	77	6	CLIP, TUBE	I2	111	3				
	G3	80	6		K8	149	41		2-D5	242	2
	G8	85	24		L16	173	15	CORD COMP., EMERGENCY	2-F9	278	4
	G9	86	6		N13	202	16	CORD, EARTH	E14	59	4
	G11	88	3		2-B1	206	17	CORD, STOP SWITCH	2-B10	215	10
CAP, PRE AIR CLEANER	L12	169	11		2-B2	207	15	COUNTERSHAFT COMP.	2-E9	262	4
CAP, REDUCTION OIL	2-E5	258	16				16	COVER ASSY., CHAIN CASE	2-E7	260	1
CARBURETOR ASSY.	I15	124	10		2-B3	208	18	COVER ASSY., CRANKCASE	F4	65	2
	I16	125	10				19		F5	66	2
	J1	126	10		2-F8	277	19		F16	77	2
	K6	147	8	CLIP, VALVE GUIDE	E2	47	4		G2	79	23
	K10	151	8	CLIP, WIRE HARNESS	K9	150	50		G3	80	2
	K12	153	2		L16	173	12		G5	82	3
CASE COMP., AIR CLEANER	L15	172	4		2-F12	281	24		G9	86	3
	L16	173	5	CLIP, WIRE HARNESS, 25MM	2-F12	281	25		G11	88	1
CASE COMP., PRE AIR CLEANER ..	L12	169	10	CLIP, WIRE HARNESS, 6MM	I9	118	27	COVER ASSY., REDUCTION CASE ..	2-E9	262	1
CASE COMP., RECOIL STARTER ...	H7	100	2	CLUTCH COMP., OVERRUNNING	2-B14	219	5	COVER COMP., AIR CLEANER	L11	168	5
	H8	101	2	COCK ASSY., FUEL	2-B1	206	2		L15	172	6
CASE, CONTROL	2-D7	244	2		2-B3	208	4		L16	173	7
	2-D11	248	3		2-F8	277	2	COVER COMP., FAN	I2	111	5

PART NAME INDEX

Part name	Address	Page	Ref.	Part name	Address	Page	Ref.	Part name	Address	Page	Ref.
COVER COMP., FAN	I3	112	5	ELEMENT, AIR CLEANER	K13	154	2	GASKET, EX. PIPE	M9	182	7
	I4	113	5		K15	156	7		M15	188	6
COVER COMP., HEAD	E2	47	6		L2	159	2		N1	190	4
	E3	48	6		L11	168	2				5
COVER COMP., MUFFLER	M4	177	12		L13	170	2		N3	192	6
	M10	183	12		L15	172	2				7
	N1	190	7		L16	173	3		N4	193	5
COVER COMP., MUFFLER RR.	M4	177	13	EMBLEM	2-E11	264	3	GASKET, MUFFLER	M4	177	9
	M10	183	13		2-E12	265	3				10
	N1	190	8		2-F3	272	2		M10	183	9
COVER, AIR CLEANER	K13	154	4	E-RING, 2MM	K8	149	38				10
	K15	156	3	E-RING, 4MM	K8	149	39		M15	188	8
	L2	159	4		K11	152	27		M16	189	8
	L3	160	5		2-D6	243	11				13
	L13	170	4	E-RING, 5MM	K11	152	28	GAUGE ASSY., FUEL	N7	196	4
COVER, CONTROL	K13	154	1	E-RING, 7MM	K8	149	40	GAUGE ASSY., THICKNESS	2-F5	274	6
COVER, DUCT	G11	88	16					GAUGE, OIL LEVEL	2-E5	258	17
COVER, REDUCTION	2-E4	257	2	[F]				GEAR, DRIVE PINION	2-B15	220	8
CRANKSHAFT COMP.	G12	89	1	FAN, COOLING	2-B4	209	1	GEAR, PRIMARY DRIVE	2-E9	262	3
			2	FAN, GENERATOR COOLING	2-F13	282	1	GEAR, REDUCTION	2-B16	221	13
	G13	90	2	FILTER COMP., FUEL	2-B1	206	10	GOVERNOR ASSY.	F8	69	9
			3		2-B2	207	14		F15	76	23
			4		2-B3	208	13		F16	77	10
			5	FILTER, CUP	2-B1	206	5		G3	80	9
			6		2-F8	277	5		G6	83	7
	G14	91	6	FILTER, DRAIN TUBE	L15	172	10		G8	85	20
			14		L16	173	11		G9	86	10
CUP, FUEL STRAINER	J11	136	25	FILTER, FUEL	N10	199	9		G11	88	4
	2-B1	206	6				10	GRID, AIR CLEANER	K13	154	3
	2-B3	208	7		2-F8	277	11		K15	156	2
	2-F8	277	6	FILTER, OUTER	L2	159	3	GRIP	2-F5	274	5
[D]					L11	168	3	GRIP, REINFORCEMENT	H14	107	12
DEFLECTOR COMP., MUFFLER	M4	177	11	FLANGE COMP., BAFFLE	L13	170	3	GRIP, SCREW DRIVER	2-F7	276	14
	M10	183	11	FLOAT SET	M16	189	12	GRIP, STARTER	H13	106	10
DIAPHRAGM ASSY.	K8	149	24		I12	121	3	GROMMET, AIR CLEANER	2-F11	280	8
DISK, CLUTCH FRICTION	2-E4	257	5		K6	147	3		L4	161	6
DOWEL PIN, 12X20	E6	51	15	FLYWHEEL COMP.	K10	151	3		L11	168	6
DOWEL PIN, 8X12	F12	73	16		K10	151	3	GROMMET, CHOKE ROD	L13	170	5
	G1	78	17		2-B5	210	5	GROMMET, CORD	K8	149	26
	G7	84	13				6	GROMMET, CORD	2-B9	214	8
	G10	87	17		2-B6	211	7	GROMMET, CRANKCASE	2-B11	216	16
	G11	88	10				10	GROMMET, CRANKCASE	2-F6	275	22
DOWEL PIN, 8X14	G3	80	17	FRAME COMP., UNDER	2-F13	282	8	GROMMET, CRANKCASE	2-F13	282	17
	2-E6	259	28	FUSE, BLADE	2-D8	245	23	GROMMET, DRAIN HOLE	I8	117	16
	2-E8	261	11		2-D16	253	25	GROMMET, FENDER	K8	149	30
	2-E9	262	11		2-E3	256	16	GROMMET, WIRE CORD	2-B3	208	14
DRIVER 3, MINUS SCREW	2-F7	276	13	[G]				GUIDE, CHOKE ROD	K8	149	27
DUCT, LOWER MUFFLER	N4	193	2	GASKET KIT	2-F15	284	1	GUIDE, EX. VALVE	E2	47	3
DUCT, UPPER MUFFLER	N4	193	3	GASKET SET	I10	119	1	GUIDE, IN. VALVE	E2	47	2
[E]					I11	120	1	GUIDE, PRE AIR CLEANER	L12	169	12
ELBOW COMP., AIR CLEANER	K13	154	7		I12	121	1	GUIDE, UNDER AIR	2-F13	282	9
	K15	156	8		K6	147	1	[H]			
	L6	163	9		K10	151	1	HANDLE, BOX WRENCH	2-F6	275	9
	L12	169	9	GASKET, CYLINDER HEAD	E2	47	5		2-F7	276	4
	L14	171	9	GASKET, EX. PIPE	M3	176	7	HARNESS ASSY., SUB WIRE	2-D8	245	25
					M8	181	7		2-E1	254	29
									2-E2	255	6



PART NAME INDEX

Part name	Address	Page	Ref.	Part name	Address	Page	Ref.	Part name	Address	Page	Ref.
HARNASS ASSY., SUB WIRE	2-F11	280	9	JOINT, ROD	K7	148	19	MARK, AIR CLEANER	2-E16	269	25
HEAD COMP., CYLINDER	E1	46	1		2-D5	242	1		2-F9	278	10
	E2	47	1		2-F11	280	3	MARK, AIR CLEANER CAUTION	2-E14	267	9
HOLDER, BRUSH	2-B16	221	14					MARK, AIR CLEANER SALES POINT	2-E16	269	22
HOLDER, CABLE	K11	152	23	[K]				MARK, CAUTION	2-E12	265	4
	2-C12	233	13								5
			14	KEY ASSY., COMBINATION SWITCH	2-F9	278	13		2-E13	266	5
	2-D5	242	8	KEY COMP.	2-D8	245	9				6
HOLDER, CLUTCH SPRING	2-E4	257	9		2-D13	250	11		2-F3	272	3
HOLDER, CLUTCH WEIGHT	2-E5	258	11		2-E2	255	10		2-F4	273	14
HOLDER, FUEL FILTER	N10	199	11	KEY, 6.3X6.3X33	2-E8	261	8		2-F9	278	17
HOLDER, GOVERNOR WEIGHT	F10	71	11	KEY, 6.3X6.3X43	G14	91	12	MARK, CHOKE	2-E14	267	10
	F15	76	25		2-E9	262	9				11
	G1	78	12	KEY, 6.3X6.3X63	2-E9	262	9				12
	G3	80	11	KEY, 7X7X33	G14	91	12		2-F3	272	5
	G6	83	9		2-E6	259	19		2-F9	278	16
	G8	85	22		2-E7	260	8				19
	G9	86	12		2-E8	261	8		2-F10	279	19
	G11	88	6	KEY, CLUTCH CENTER	2-E6	259	20	MARK, CONTROL BOX	2-D8	245	13
HOLDER, STOP SWITCH CORD	I8	117	12	KEY, SPECIAL WOODRUFF, 25X18 ..	2-B6	211	9		2-D14	251	15
	2-B10	215	11	KNOB, COCK LEVER	2-F11	280	10		2-E2	255	11
	2-D8	245	10						2-F9	278	14
	2-D13	250	12	[L]				MARK, EARTH			
HOLDER, WIRE	2-C14	235	20					MARK, EMERGENCY SWITCH			
			21	LABEL, AIR CLEANER CAUTION	2-E16	269	21	INDICATION	2-E11	264	2
[I]					2-F10	279	20	MARK, ENGINE CONTROL	2-F9	278	9
INSULATOR	2-C1	222	16	LABEL, CAUTION	2-E13	266	7	MARK, ENGINE SWITCH	2-E15	268	15
INSULATOR A, LOWER MUFFLER					2-E14	267	7		2-E16	269	19
DUCT	N4	193	10		2-E14	267	7	MARK, EX. CAUTION	2-E16	269	26
INSULATOR A, UPPER MUFFLER				LABEL, E-SPEC	2-F9	278	18		2-F9	278	5
DUCT	N4	193	12		2-F1	270	27	MARK, EX. GAS WARNING	2-F4	273	12
INSULATOR B, LOWER MUFFLER					2-F2	271	30	MARK, FUEL INDICATION	2-E16	269	23
DUCT	N4	193	11		2-F4	273	16		2-F4	273	11
INSULATOR B, UPPER MUFFLER				LABEL, FUEL CAUTION	2-F1	270	29	MARK, FUEL WARNING	2-F4	273	13
DUCT	N4	193	13	LABEL, FUEL WARNING	2-F3	272	3	MARK, HEAT CAUTION	2-F4	273	15
INSULATOR, CARBURETOR	J4	129	15	LABEL, SPECIFICATION	2-E14	267	13	MARK, OIL ALERT	2-E15	268	14
	K7	148	13		2-F3	272	6				15
	K9	150	53	LABEL, WARNING	2-F2	271	31		2-E16	269	17
	K10	151	13	LENS ASSY., PROTECTOR	2-D8	245	12				18
	K12	153	5		2-D14	251	14	MARK, OIL CAUTION	2-E16	269	24
[J]				LEVER COMP., CHOKE	J7	132	19		2-F4	273	17
JET SET, PILOT,	K2	143	29		K12	153	9	MARK, THROTTLE INDICATION	2-E15	268	16
	K3	144	29	LEVER COMP., ENGINE SWITCH	2-F11	280	1		2-E16	269	16
	K9	150	45	LEVER COMP., SOLENOID THROTTLE	2-D6	243	5	METER ASSY., FUEL	2-B1	206	7
	K11	152	30	LEVER, CHOKE	K7	148	18		2-B3	208	8
JET, MAIN,	J14	139	28	LEVER, COCK	J8	133	20		2-F8	277	7
	J15	140	28	LEVER, COCK	J8	133	20	METER COMP., FUEL	2-B2	207	7
	J16	141	28	LEVER, CONTROL	2-C10	231	10	MOTOR ASSY., STARTER	2-B13	218	1
	K1	142	28	LEVER, REMOTE CHOKE	K11	152	20	MUFFLER COMP.	M1	174	2
	K2	143	28	LIFTER, VALVE	H2	95	4		M7	180	2
	K8	149	44						M15	188	1
	K9	150	44	[M]					N1	190	2
	K11	152	29	MARK AB, CAUTION	2-F9	278	8		N3	192	1
JET, PILOT,	K12	153	12	MARK A, COMBINATION	2-F3	272	1		N4	193	1
JOINT, FUEL TANK	N6	195	2	MARK B, COMBINATION	2-F3	272	4	[N]			
				MARK V, CAUTION	2-F9	278	7				
				MARK, AIR CLEANER	2-E16	269	20	NOSE, SILENCER	L10	167	15



PART NAME INDEX

Part name	Address	Page	Ref.	Part name	Address	Page	Ref.	Part name	Address	Page	Ref.
NOSE, SILENCER	L13	170	6	NUT, WING, 6MM	K14	155	10	PACKING, FUEL STRAINER CUP	2-B3	208	1
NOZZLE, MAIN	J2	127	13		K16	157	11		2-F8	277	1
	J3	128	13		L6	163	11	PACKING, HEAD COVER	E4	49	8
	K7	148	11		L12	169	15	PACKING, INSULATOR	J6	131	18
	K10	151	11		L14	171	11		K7	148	15
NUT-WASHER, 6MM	2-C4	225	24	[O]					K10	151	15
NUT, AIR CLEANER COVER	K13	154	10					PACKING, OIL FILLER CAP	K12	153	8
	K16	157	11						F7	68	7
	L6	163	11	OIL SEAL	2-E6	259	22				8
	L12	169	15	OIL SEAL, 30X45X8	F12	73	17		F8	69	8
	L14	171	11	OIL SEAL, 30X46X8	E14	59	9		F16	77	7
NUT, CAP, 6MM	K13	154	9		F13	74	17				8
	K16	157	10		G7	84	14				9
	L6	163	10		G11	88	11		G3	80	7
	L12	169	14		2-E6	259	21				8
	L14	171	10		2-E8	261	9		G6	83	6
NUT, FLANGE, 10MM	E16	61	11		2-E9	262	10		G8	85	25
	2-F13	282	20	0-RING	2-B1	206	4				26
NUT, FLANGE, 5MM	L15	172	11		2-F8	277	4		G9	86	7
	L16	173	13	0-RING, 14MM	E15	60	10				8
NUT, FLANGE, 6MM	K14	155	14		N10	199	12				9
	K16	157	14	0-RING, 26X2.7	F15	76	22	PACKING, REDUCTION COVER	2-E4	257	3
	L9	166	14		G11	88	12	PANEL COMP., CONTROL	2-D7	244	4
	L12	169	18		2-E6	259	23		2-D11	248	5
	L14	171	14	[P]					2-D12	249	5
	L15	172	12						2-E2	255	4
			13	PACKING	2-C2	223	21	PANEL, CONTROL BOX	2-D8	245	13
	L16	173	14	PACKING C, FUEL METER	2-B2	207	12		2-D14	251	15
	2-B3	208	16	PACKING, AIR CLEANER	K8	149	23	PAN, CLEANER OIL	K15	156	6
	2-D4	241	35		K11	152	22	PIN, GOVERNOR WEIGHT	F10	71	12
	2-D5	242	18	PACKING, AIR CLEANER COVER	L11	168	4		G1	78	13
	2-F12	281	29	PACKING, CARBURETOR	J5	130	17		G3	80	12
NUT, FLANGE, 8MM	M6	179	26		J6	131	17		G6	83	10
	M13	186	27		K7	148	14		G8	85	23
	M16	189	11		K10	151	14		G9	86	13
	N2	191	19		K12	153	7	PIN, LOCK, 10MM	G11	88	7
	N3	192	9	PACKING, CASE COVER	F6	67	3		F1	62	13
	N11	200	14		F16	77	3	PIN, LOCK, 8MM	F2	63	13
	2-F13	282	19		G3	80	3		E16	61	13
NUT, HEX., 16MM	2-F9	278	6		G5	82	2	PIN, PISTON	2-F6	275	12
NUT, HEX., 4MM	2-D8	245	21		G9	86	2		G16	93	3
	2-D16	253	23		G11	88	2	PIN, ROLLER ARM, 8X22	2-F6	275	11
	2-E3	256	14	PACKING, CHAIN CASE COVER	2-E7	260	2	PIN, SPLIT, 2.0X18	2-F12	281	30
NUT, HEX., 5MM	M6	179	23		2-E9	262	2	PIN, SPRING, 2X12	J13	138	27
	M12	185	23		K15	156	1		K12	153	11
	N2	191	16	PACKING, ELBOW	L1	158	1	PIN, SPRING, 2X6	2-D6	243	10
NUT, HEX., 8MM	N4	193	16		L11	168	1	PIPE COMP., EX.	N4	193	4
NUT, PIVOT ADJUSTING	H3	96	15		L13	170	1	PIPE, BOX WRENCH EXTENSION	2-F6	275	10
NUT, PUSH, 2.6	2-F11	280	19		J10	135	24	PIPE, EX.	M2	175	5
NUT, SELF-LOCK, 6MM	2-D2	239	27	PACKING, FUEL COCK	N10	199	8		M8	181	5
NUT, SPECIAL, 16MM	2-B6	211	8	PACKING, FUEL FILLER CAP	N15	204	22		M15	188	4
NUT, SPECIAL, 6MM	2-F13	282	16		N16	205	24		N1	190	3
NUT, TOOL BOX SETTING	K14	155	11		2-B1	206	9	PISTON	N3	192	5
	K16	157	12		2-B2	207	13		G15	92	2
	L7	164	12		2-B3	208	12		G16	93	2
	L8	165	12		2-F8	277	10	PIVOT, ROCKER ARM	H3	96	5
	L12	169	16		J4	129	14	PLATE COMP., CLUTCH PRESSURE	2-E4	257	7
	L14	171	12	PACKING, FUEL STRAINER CUP	2-B1	206	1	PLATE, CLUTCH	2-E4	257	6
NUT, WING	K14	155	10					PLATE, COOLING FAN SETTING	2-B4	209	2



PART NAME INDEX

Part name	Address	Page	Ref.	Part name	Address	Page	Ref.	Part name	Address	Page	Ref.
PLATE, FUEL INDICATION	2-F4	273	11	ROPE, RECOIL STARTER	H14	107	11	SCREW, PAN, 4X12	2-D8	245	20
	2-F8	277	13	ROTATOR, VALVE	H3	96	12		2-D16	253	22
PLATE, LEVER SETTING	J9	134	21	RUBBER, BOTTOM	2-F6	275	18		2-E3	256	13
PLATE, PUSH ROD GUIDE	H3	96	13					SCREW, PAN, 4X6	2-D2	239	30
PLATE, SET	M4	177	16		2-F13	282	11				31
	M10	183	16					SCREW, PAN, 4X8	K11	152	25
	N2	191	11	RUBBER, FUEL	M14	203	19	SCREW, PAN, 5X12	K8	149	35
PLUG, CONE TYPE	K14	155	12		2-B1	206	13	SCREW, PAN, 5X16	2-D4	241	33
PLUG, OIL DRAIN	F3	64	19		2-F8	277	15	SCREW, PAN, 5X16.5	L12	169	13
PLUG, SEALING	E14	59	8	RUBBER, SUPPORTER	N5	194	1	SCREW, PAN, 5X25	2-D5	242	16
PLUG, SPARK	E6	51	17		N6	195	1	SCREW, PAN, 5X28	2-D3	240	32
	E7	52	17		2-B2	207	3	SCREW, PAN, 5X32	I9	118	24
	E8	53	17	RUBBER, TANK CUSHION	2-B1	206	12	SCREW, PAN, 5X35	2-D4	241	37
	E9	54	17		2-F8	277	14		2-D5	242	17
	E10	55	17	RUBBER, TANK MOUNTING	2-F8	277	12	SCREW, PAN, 5X8	I9	118	23
	2-F6	275	21						2-D6	243	9
PLUG, USELESS HOLE	I9	118	26	[S]				SCREW, RECESSED, 5X25	2-D2	239	26
PROTECTOR COMP., FAN COVER ...	I5	114	6	SCREEN, FUEL STRAINER	2-B1	206	3	SCREW, SPECIAL, 6X12	2-D8	245	15
PROTECTOR COMP., MUFFLER	M2	175	3		2-F8	277	3		2-D15	252	17
	M8	181	3	SCREW-WASHER, 4X6	2-C2	223	19	SCREW, TAPPING, 4X6	M6	179	22
PROTECTOR, CIRCUIT	2-D8	245	11	SCREW-WASHER, 5X12	K9	150	51				29
	2-D13	250	13		K11	152	26		M12	185	22
	2-D14	251	13		M6	179	24		M14	187	31
PROTECTOR, EX. PIPE	M2	175	4		M12	185	24		M16	189	10
	M6	179	30		N2	191	17				14
	M8	181	4	SCREW-WASHER, 5X14	2-C2	223	22	SCREW, TAPPING, 4X8	N2	191	15
PROTECTOR, L. MUFFLER	M15	188	3	SCREW-WASHER, 5X16	2-D4	241	33	SCREW, TAPPING, 5X14	2-F13	282	15
PROTECTOR, MUFFLER INNER	N3	192	3					SCREW, TAPPING, 5X25	M5	178	21
PROTECTOR, MUFFLER OUTER	N3	192	2	SCREW-WASHER, 5X32	2-C3	224	23		M12	185	21
PROTECTOR, R. MUFFLER	M15	188	2	SCREW-WASHER, 6X20	M6	179	25		N2	191	14
PULLEY COMP., STARTER	2-B4	209	3		M12	185	25	SCREW, TAPPING, 5X8	M5	178	19
PULLEY, RECOIL STARTER	H9	102	3	SCREW SET	N2	191	18				20
PULLEY, STARTER	2-B5	210	4		I14	123	8		M6	179	29
					K4	145	30		M11	184	19
[R]					K6	147	7		M12	185	20
RATCHET, STARTER	H10	103	4		K9	150	48		M14	187	31
RECTIFIER ASSY., REGULATOR ...	2-D8	245	24				52		M16	189	9
	2-E1	254	28		K10	151	7				14
	2-E2	255	5	SCREW SET, DRAIN	K11	152	31	SCREW, TAPPING, 6X10	N2	191	13
RECTIFIER ASSY., SILICON	2-D7	244	5		I14	123	7	SCREW, THROTTLE STOP	M12	185	26
	2-D12	249	6		K4	145	31		J2	127	11
	2-F9	278	1		K6	147	6		K6	147	9
RECTIFIER COMP., REGULATOR ...	2-F9	278	11		K9	150	47		K10	151	9
RETAINER, EX. VALVE SPRING ...	H3	96	11		K10	151	6		K12	153	3
RETAINER, IN. VALVE SPRING ...	H3	96	10	SCREW SET, PILOT	I14	123	6	SCROLL, GENERATOR FAN	I1	110	1
			11		K4	145	30	SEAL, AIR CLEANER	L15	172	9
RETAINER, SPRING	H12	105	8		K6	147	5		L16	173	10
RING SET, PISTON	G15	92	1		K10	151	5	SEAL, CHOKE LEVER	K8	149	32
RING, SNAP	2-B13	218	2	SCREW, CENTER	H15	108	13	SEAL, ENGINE SWITCH LEVER	2-F11	280	15
ROD ASSY., CONNECTING	G16	93	4	SCREW, FLAT, 5X10	N10	199	13	SEAL, FUEL FILLER NECK	2-B2	207	10
ROD, CHOKE	K7	148	20		2-B1	206	15		2-B3	208	10
	2-D5	242	12		2-B3	208	15	SEAL, MUFFLER DUCT	N4	193	7
ROD, CHOKE CONTROL	K8	149	25		2-F8	277	17				8
ROD, COCK CONTROL	2-F11	280	5	SCREW, PAN, 3X12	2-D8	245	19				9
ROD, GOVERNOR	2-C6	227	2		2-D16	253	21	SEAL, MUFFLER PROTECTOR	N3	192	4
	2-D5	242	4	SCREW, PAN, 3X6	J12	137	26	SEAL, UNDER AIR GUIDE	2-F13	282	10
ROD, GOVERNOR CONTROL PUSH ...	2-F11	280	2	SCREW, PAN, 3X8	J12	137	26	SEAL, VALVE STEM	H4	97	16
ROD, PUSH	H2	95	2		2-F12	281	28	SEAT, VALVE SPRING	E4	49	9

PART NAME INDEX

2-H 7

Part name	Address	Page	Ref.	Part name	Address	Page	Ref.	Part name	Address	Page	Ref.
SEPARATOR, AIR CLEANER	L15	172	3	SPROCKET COMP., DRIVE	2-E5	258	13	TUBE, 11X100	E4	49	7
	L16	173	4	SPROCKET, DRIVE	2-E7	260	4	TUBE, 11X105	E3	48	7
SHAFT	2-C2	223	18	STARTER ASSY., RECOIL	H5	98	1	TUBE, 3.5X130	K8	149	43
SHAFT COMP., P.T.O.	2-E5	258	15		H6	99	1	TUBE, 3.5X175	2-F12	281	32
SHAFT, GOVERNOR ARM	E14	59	3	STAY ASSY., CHOKE CONTROL	2-C14	235	18	TUBE, 3.5X40	K8	149	42
SHAFT, P.T.O.	2-E7	260	5	STAY ASSY., MANUAL CHOKE	K7	148	16	TUBE, 3.5X55	K8	149	42
	2-E9	262	5		K9	150	54	TUBE, 3.5X65	K8	149	42
SHAFT, SCREW DRIVER	2-F5	274	4	STAY ASSY., REMOTE CHOKE	K10	151	18	TUBE, 3.5X75	K8	149	43
SHIM A	2-E9	262	6	STAY COMP., MUFFLER	N4	193	6	TUBE, 3.5X85	2-F12	281	31
SHIM B	2-E9	262	7	STAY COMP., REMOTE CHOKE	K10	151	19	TUBE, BREATHER	E3	48	7
SHROUD	I6	115	7	STAY COMP., SOLENOID	K7	148	17		L15	172	1
SHROUD ASSY., UPPER	I2	111	4	STAY, AIR CLEANER	L15	172	5		L16	173	1
SHROUD COMP., LOWER	I6	115	8		L16	173	6	TUBE, FASTENER, 30MM	2-D8	245	18
SLIDER, GOVERNOR	F10	71	13	STAY, MUFFLER COVER	M4	177	15		2-D16	253	20
	F11	72	13		M10	183	15	TUBE, FUEL	2-B3	208	2
	G1	78	14		N1	190	10	TUBE, FUEL SUPPORTER	2-B3	208	3
	G3	80	13	STAY, SOLENOID THROTTLE	2-D6	243	4	TUBE, FUEL TANK	2-B2	207	1
	G6	83	11	STOPPER, CHOKE ROD	K8	149	21	TUBE, FUEL, 4.5X120	N14	203	20
	G9	86	14	STOPPER, DISCHARGE GUARD	2-B1	206	18	TUBE, FUEL, 4.5X150	N14	203	21
	G10	87	14	STRAINER COMP., FUEL	N14	203	18		2-B1	206	16
	G11	88	8		2-B2	207	4	TUBE, FUEL, 4.5X222	N12	201	15
SOLENOID ASSY.	2-D6	243	6	STRAINER, FUEL	2-B3	208	5	TUBE, FUEL, 4.5X250	2-B3	208	17
SPACER COMP., CARBURETOR	J5	130	16	STRAP, CABLE, 118MM	2-D8	245	17		2-F8	277	18
	K12	153	6		2-D15	252	19	TUBE, FUEL, 4.5X430	N12	201	15
SPACER, CONTROL LEVER	2-C12	233	15	SUB HARNESS	E14	59	4	TUBE, VINYL, 4.5X8X230	L16	173	16
SPACER, MUFFLER COVER	M4	177	17		I6	115	10	TUBE, VINYL, 4.5X8X380	L16	173	17
	M11	184	17		2-D12	249	8				
	N2	191	12	SUSPENSION, COUPLER	2-E2	255	7	[V]			
SPANNER, 10X12	2-F6	275	13		2-D7	244	6	VALVE ASSY., SOLENOID	K9	150	49
	2-F7	276	8		2-D12	249	7				
SPANNER, 10X14	2-F6	275	14	SUSPENSION, STRAINER	2-B2	207	5	VALVE SET, FLOAT	K10	151	16
SPANNER, 14X17	2-F6	275	15	SWITCH ASSY., COMBINATION	2-D8	245	8		I12	121	2
	2-F7	276	9		2-D12	249	10	VALVE, DASHPOT CHECK	K6	147	2
SPRING	2-C2	223	17		2-D13	250	10		K10	151	2
SPRING, BRUSH RETURN	2-B16	221	12		2-E2	255	9	VALVE, EX.	K8	149	28
SPRING, CABLE RETURN	2-C14	235	19		2-F9	278	12		K12	153	10
	2-D5	242	10	SWITCH ASSY., EMERGENCY STOP ..	2-F9	278	3	VALVE, IN.	2-F11	280	14
			11		2-F10	279	21		H3	96	8
SPRING, CHOKE RETURN	K11	152	21	SWITCH ASSY., ENGINE STOP	I1	110	2		H3	96	7
	2-D6	243	2		I6	115	11	[W]			
SPRING, CLUTCH FREE	2-E4	257	8	SWITCH ASSY., KILL	I7	116	11	WASHER COMP., HEAD COVER	E6	51	14
SPRING, COCK LEVER	J10	135	23	SWITCH ASSY., OIL LEVEL	E14	59	2	WASHER, 10.5X40X4	2-E7	260	7
SPRING, CONTROL ADJUSTING	I9	118	29					WASHER, 11.7MM	G14	91	10
	2-C14	235	17	[T]				WASHER, 6X16	F12	73	14
	2-D5	242	9	TANK ASSY., FUEL	N6	195	3		G1	78	15
SPRING, FRICTION	H10	103	5	TANK COMP., FUEL	N7	196	5		G3	80	14
SPRING, GOVERNOR	2-C7	228	3		N8	197	5		G8	85	19
	2-C8	229	3		2-B2	207	9				27
	2-D5	242	6		2-B3	208	9		G10	87	15
	2-F9	278	15		2-F8	277	8		G11	88	18
SPRING, LEVER	2-C10	231	11	TERMINAL ASSY., EARTH	2-F13	282	2	WASHER, 8MM	2-E7	260	6
SPRING, MANUAL CHOKE	K8	149	22	TERMINAL ASSY., HIGH TENSION ..	2-B7	212	2		2-E9	262	8
SPRING, RATCHET	H12	105	7	TOOL KIT	2-F5	274	2	WASHER, 8.2X17X0.8	E14	59	7
SPRING, RETURN	2-C15	236	23		2-F7	276	1	WASHER, CENTER COVER	2-F11	280	23
SPRING, STARTER RETURN	H11	104	6	TUBE ASSY., COCK-CARBURETOR ...	2-B2	207	2	WASHER, CHOKE LEVER	K8	149	31
SPRING, THROTTLE RETURN	2-C8	229	4					WASHER, CONTROL LEVER	2-C11	232	12
	2-D5	242	7								
SPRING, VALVE	H3	96	9								
SPRING, WEIGHT RETURN	H3	96	6								

4

PART NAME INDEX

Part name	Address	Page	Ref.	Part name	Address	Page	Ref.	Part name	Address	Page	Ref.
WASHER, DRAIN PLUG, 12MM	E16	61	12								
	2-E6	259	26								
WASHER, LOCK, 8MM	G14	91	11								
	2-E7	260	7								
WASHER, PLAIN, 4MM	2-E1	254	27								
	2-E3	256	18								
WASHER, PLAIN, 5MM	K8	149	37								
	M6	179	27								
	M13	186	28								
	N2	191	20								
WASHER, PLAIN, 6MM	F14	75	18								
	G1	78	18								
	G3	80	16								
	G8	85	15								
	G10	87	18								
	G11	88	13								
WASHER, SK	2-C2	223	20								
WASHER, SPRING, 4MM	2-D8	245	22								
	2-D16	253	24								
	2-E3	256	15								
WASHER, SPRING, 5MM	M6	179	28								
	M14	187	29								
			30								
	N2	191	21								
	2-D5	242	19								
WASHER, SPRING, 8MM	2-E6	259	27								
WASHER, TANK CUSHION	2-B1	206	11								
WASHER, THRUST, 25MM	2-E6	259	18								
WASHER, THRUST, 2.7X8	K8	149	33								
	2-F11	280	20								
WASHER, WAVE, 10MM	2-F11	280	22								
WEIGHT, BALANCER	G14	91	15								
WEIGHT, CLUTCH	2-E5	258	10								
WEIGHT, GOVERNOR	F9	70	10								
	F15	76	24								
	G1	78	11								
	G3	80	10								
	G6	83	8								
	G8	85	21								
	G9	86	11								
	G11	88	5								
WHEEL COMP.	2-F13	282	4								
			5								
WIRE, WATER COVER	2-C1	222	15								
WRENCH COMP., SPARK PLUG	2-F6	275	8								
	2-F7	276	2								
			3								
WRENCH, BOX	2-F5	274	7								
	2-F6	275	16								
	2-F7	276	10								
WRENCH, PLUG	2-F6	275	20								
[Y]											
YOKE COMP.	2-B16	221	10								

1

FOREWORD INDEX

2

ENGINE GROUP

3

PART NUMBER INDEX

4

PART NAME INDEX

HONDA
The Power of Dreams



PARTS CATALOGUE NEWS

Honda Motor Co., Ltd. Service Division

PARTS CATALOGUE - CORRECTED

Printed in Japan

CODE NO.	BOOKLET TYPE	13ZH90E9
	MICRO-FICHE	13ZH90EI/FI
PARTS CATALOGUE TITLE	GX270 GX270[PROPANE ENGINE]	
NEWS NO.	001	

Block No.	Ref. No.	Note	Part No.	Description	Reqd. QTY			Serial No.	Parts catalogue code
					(1)	(2)	(3)		
E-17	5		17510-ZE2-020ZA	TANK COMP., FUEL *NH31*. MCKINLEY WHITE	1	(1)	-	2205580 2400587	ES1/A, HA2/A, HEA2/A, HEA8/A, HX/A, HXQ4/A, HX26/A, HX8/A LH/A, LHB5, LHE/A, LJ/A, LJC/A, LT/A, LW/A, LX/A, LXE/A LXE8/A, LXQ4/A, LXU/A, L1/A, PAE2/A, PA2/A, PX/A, PXE8/A PXU/A, PX26/A, QAB3/A, QAE2/A, QAE6/A, QAG/A, QAG2/A, QAQ4/A QAR2/A, QAW/A, QA2/A, QD/A, QE/A, QH/A, QHB5, QHE4/A, QHP1/A QHQ4/A, QHR/A, QHR4/A, QHZ/A, QH26/A, QME2/A, QMH/A, QP/A QSE/A, QSE2, QSE8/A, QT/A, QWA4/A, QX/A, QXB/A, QXB6/A QXB7/A, QXC4/A, QXC6/A, QXC9/A, QXE/A, QXE4/A, QXE6/A QXE8/A, QXQ4/A, QXU/A, QX26/A, Q1/A, RA2/A, RD/A, RHE4/A RHQ4/A, RH26/A, RX/A, RXQ4/A, RXU/A, R1/A, SD/A, SE/A, SH/A SHQ4/A, SJ/A, SMC4/A, SME1/A, SME6/A, SN/A, SWC4/A, SX/A SXB/A, SXB7/A, SXE/A, SXEB/A, SXE4/A, SXE8/A, SXQ4/A, SXU/A S1/A, VA2/A, VME2/A, VM2/A, VSD/A, VSD7/A, VX/A, VXB/A VXB7/A, VXEB/A, VXE4/A, VXE6/A, VXE7/A, VXQ4/A, VXU/A VXU1/A, WMT8/A, WXE8/A, W1/A
					1	-	-	----- 2400587	SWA4, WMA4
			17510-ZE2-020ZD	*NH1*. BLACK	1	-	-	----- 2400587	SMX2, VMA4, VME4
					1	-	-	2205580 2400587	HA2/A, PA2/A, PX/A, PXU/A, QAE2/A, QAQ4/A, QAR2/A, QA2/A QWA4/A, QWH2/A, QXB/A, QXC9/A, RA2/A, SWC4/A, VA2/A, VME2/A VM2/A, VXE4/A, VXE7/A, VXU/A
			17510-ZE2-020ZE	*NH105*. . . MAT BLACK (#15-#20)	1	-	-	2205580 2400587	VME2/A, VM2/A

NOTE A:PART NO. CHANGE D:NEWLY PROVIDED E:PART NO.DELETION K:REQUIRED NO. CORRECTION L:APPLICATION SERIAL NO. CORRECTION
T:APPLICATION CORRECTION Z:REMARKS CHANGE

PARTS CATALOGUE NEWS

BOOKNo. : 13ZH90E9

Block No.	Ref. No.	Note	Part No.	Description	Reqd. QTY			Serial No.		Parts catalogue code
					(1)	(2)	(3)			
			17510-ZE2-020ZH	*R280* POWER RED	1	-	-	2205580	2400587	ES1/A
	A		17510-ZE2-800ZA	*NH1* BLACK	1	-	-	2400588	-----	HA2/A, PA2/A, PX/A, PXU/A, QAE2/A, QAQ4/A, QAR2/A, QA2/A, QWA4/A, QWH2/A, QXB/A, QXC9/A, RA2/A, SMX2, SWC4/A, VA2/A, VMA4, VME2/A, VME4, VM2/A, VXE4/A, VXE7/A, VXU/A
	A		17510-ZE2-800ZB	*NH105* MAT BLACK (#15-#20)	1	-	-	2400588	-----	VME2/A, VM2/A
	A		17510-ZE2-800ZC	*NH31* MCKINLEY WHITE	1	(1)	-	2400588	-----	ES1/A, HA2/A, HEA2/A, HEA8/A, HX/A, HXQ4/A, HX26/A, HX8/A, LH/A, LHB5, LHE/A, LJ/A, LJC/A, LT/A, LW/A, LX/A, LXE/A, LXE8/A, LXQ4/A, LXU/A, L1/A, PAE2/A, PA2/A, PX/A, PXE8/A, PXU/A, PX26/A, QAB3/A, QAE2/A, QAE6/A, QAG/A, QAG2/A, QAQ4/A, QAR2/A, QAW/A, QA2/A, QD/A, QE/A, QH/A, QHB5, QHE4/A, QHP1/A, QHQ4/A, QHR/A, QHR4/A, QHZ/A, QH26/A, QME2/A, QMH/A, QP/A, QSE/A, QSE2, QSE8/A, QT/A, QWA4/A, QX/A, QXB/A, QXB6/A, QXB7/A, QXC4/A, QXC6/A, QXC9/A, QXE/A, QXE4/A, QXE6/A, QXE8/A, QXQ4/A, QXU/A, QX26/A, Q1/A, RA2/A, RD/A, RHE4/A, RHQ4/A, RH26/A, RX/A, RXQ4/A, RXU/A, R1/A, SD/A, SE/A, SH/A, SHQ4/A, SJ/A, SMC4/A, SME1/A, SME6/A, SN/A, SWA4, SWC4/A, SX/A, SXB/A, SXB7/A, SXE/A, SXEB/A, SXE4/A, SXE8/A, SXQ4/A, SXU/A, S1/A, VA2/A, VME2/A, VM2/A, VSD/A, VSD7/A, VX/A, VXB/A, VXB7/A, VXE/A, VXE4/A, VXE6/A, VXE7/A, VXQ4/A, VXU/A, VXU1/A, WMA4, WMT8/A, WXE8/A, W1/A
	A		17510-ZE2-800ZD	*R280* POWER RED	1	-	-	2400588	-----	ES1/A

NOTE A:PART NO. CHANGE D:NEWLY PROVIDED E:PART NO.DELETION K:REQUIRED NO. CORRECTION L:APPLICATION SERIAL NO. CORRECTION
T:APPLICATION CORRECTION Z:REMARKS CHANGE



PARTS CATALOGUE NEWS

Honda Motor Co., Ltd. Service Division

PARTS CATALOGUE - CORRECTED

Printed in Japan

CODE NO.	BOOKLET TYPE	13ZH90E9
	MICRO-FICHE	13ZH90EI/FI
PARTS CATALOGUE TITLE	GX270 GX270[PROPANE ENGINE]	
NEWS NO.	002	

Block No.	Ref. No.	Note	Part No.	Description	Reqd. QTY			Serial No.	Parts catalogue code	
					(1)	(2)	(3)			
E-28	28	L	87135-ZE2-020	LABEL, E-SPEC (15. 5X27. 5)	1	-	-	-----	SWA4	
					1	-	-	-----	2297651	VKE4, VKX4, VNG1/A, VN17/A, VPE4/A, VPE7/A, VPX4/A, VSD3/A, VWT4/A
					1	-	-	-----	2406429	ES3/A, VMT/A, VS3, VXT1/A
					1	-	-	-----	1841643	VN17, VPE7
	30	L	87135-ZE2-020	LABEL, E-SPEC (15. 5X27. 5)	1	1	1	-----	L1, RXP/A, R1, SME1, SWA4, S1, VXP/A	
					1	1	-	-----	2406429	ESS/A, ES1/A, HX/A, HX8/A, LH/A, LHB5, LHE/A, LJ/A, LJC/A, LJG/A, LT/A, LW/A, LWD1/A, LX/A, LXE/A, LXE8/A, LXU/A, L1/A, PX/A, PXE8/A, PXU/A, QAB3/A, QD/A, QH/A, QHB5, QHP1/A, QHZ/A, QMH/A, QP/A, QSE/A, QSE8/A, QX/A, QXE/A, QXE8/A, QXU/A, Q1/A, RD/A, RSS/A, RX/A, RXU/A, R1/A, SD/A, SH/A, SJ/A, SJG/A, SX/A, SXE/A, SXE8/A, SXU/A, S1/A, VX/A, VXU/A, VXU1/A, WMT8/A, WXE8/A, W1/A
					1	-	-	-----	2297651	HXQ4/A, LXQ4/A, QAQ4/A, QE/A, QHE4/A, QHQ4/A, QHR/A, QHR4/A, QKE3/A, QME2/A, QXB/A, QXB7/A, QXC4/A, QXE4/A, QXQ4/A, RHE4/A, RHQ4/A, RXQ4/A, SE/A, SHQ4/A, SMC4/A, SME1/A, SME6/A, SXB/A, SXB7/A, SXE8/A, SXE4/A, SXQ4/A, VPX7/A, VSD/A, VSD7/A, VSH7, VS37/A, VXB/A, VXB7/A, VXE8/A, VXE4/A, VXE7/A, VXQ4/A
					1	-	-	-----	1841643	RHE4

NOTE A:PART NO. CHANGE D:NEWLY PROVIDED E:PART NO.DELETION K:REQUIRED NO. CORRECTION L:APPLICATION SERIAL NO. CORRECTION
T:APPLICATION CORRECTION Z:REMARKS CHANGE

PARTS CATALOGUE NEWS

BOOKNo. : 13ZH90E9

Block No.	Ref. No.	Note	Part No.	Description	Reqd. QTY			Serial No.	Parts catalogue code
					(1)	(2)	(3)		
E-28-1	16	L	87135-ZE2-020	LABEL, E-SPEC (15.5X27.5)	1	-	-	----- 2406429	RSS/A

NOTE A:PART NO. CHANGE D:NEWLY PROVIDED E:PART NO.DELETION K:REQUIRED NO. CORRECTION L:APPLICATION SERIAL NO. CORRECTION
T:APPLICATION CORRECTION Z:REMARKS CHANGE



PARTS CATALOGUE NEWS

Honda Motor Co., Ltd. Service Division

PARTS CATALOGUE - CORRECTED

Printed in Japan

CODE NO.	BOOKLET TYPE	13ZH90E9
	MICRO- FICHE	13ZH90EI/FI
PARTS CATALOGUE TITLE	GX270 GX270[PROPANE ENGINE]	
NEWS NO.	003	

Block No.	Ref. No.	Note	Part No.	Description	Reqd. QTY			Serial No.	Parts catalogue code
					(1)	(2)	(3)		
E-22	9		16570-ZE2-721	CONTROL ASSY.	1	-	-	-----	ES1, VAG2, VAG2/A, VAW1, VKB2, VKB2/A, VMS2, VMX2, VNT2 VNT2/A, VSD, VSD/A, VSD7, VSD7/A, VSH7, VWA, VWA2, VWA2/A VWT4, VWT4/A, VW12, VW12/A, VW22, VXG, VXT1, VXU, VXU1, VXU1/A
					1	-	-	-----	2418414 ES1/A, VXT1/A, VXU/A
		A	16570-ZE2-722	1	-	-	2418415	----- ES1/A, VXT1/A, VXU/A

NOTE A:PART NO. CHANGE D:NEWLY PROVIDED E:PART NO.DELETION K:REQUIRED NO. CORRECTION L:APPLICATION SERIAL NO. CORRECTION
T:APPLICATION CORRECTION Z:REMARKS CHANGE



PARTS CATALOGUE NEWS

Honda Motor Co., Ltd. Service Division

Printed in Japan

CODE NO.	BOOKLET TYPE	13ZH90E9
	MICRO- FICHE	13ZH90EI/FI
PARTS CATALOGUE TITLE	GX270 GX270[PROPANE ENGINE]	
NEWS NO.	004	

GX270-QXE9,QXK,VPK,VS4,VXE8 AND VXK TYPES sales parts information

NOTE: This Parts Catalogue News explains only the parts of the different model that are produced to conform to addition of the GX270-QXE9,QXK,VPK,VS4,VXE8 and VXK types.

As for the parts not listed on this Parts Catalogue News, use the parts of the GX270-QXE8/A,QXC9/A,VPE7/A,VS3,VXE7/A and VXQ4/A types.

NOTE A:PART NO. CHANGE D:NEWLY PROVIDED E:PART NO.DELETION K:REQUIRED NO. CORRECTION L:APPLICATION SERIAL NO. CORRECTION
T:APPLICATION CORRECTION Z:REMARKS CHANGE

Model	Type		Parts catalogue type	Applicable engine serial No.	Applicable carburetor identification No.
GX270	QXE8	Base model	QXE8/A	GCAB- 2000001~9999999	BE75B B
	QXE9	Additional model	QXE9		
	QXC9	Base model	QXC9/A	GCAB- 2000001~	BE75A B
	QXK	Additional model	QXK		
	VPE7	Base model	VPE7/A	GCAB- 2000001~9999999	BE21D B / C
	VPK	Additional model	VPK	GCAB- 2000001~	BE21F B
	VS3	Base model	VS3		BE77M A
	VS4	Additional model	VS4		
	VXE7	Base model	VXE7/A	GCAB- 2000001~9999999	BE75B B
	VXE8	Additional model	VXE8	GCAB- 2000001~	
	VXQ4	Base model	VXQ4/A	GCAB- 2000001~9999999	
	VXK	Additional model	VXK	GCAB- 2000001~	

NOTE A:PART NO. CHANGE D:NEWLY PROVIDED E:PART NO.DELETION K:REQUIRED NO. CORRECTION L:APPLICATION SERIAL NO. CORRECTION
T:APPLICATION CORRECTION Z:REMARKS CHANGE

PARTS CATALOGUE NEWS

BOOKNo. : 13ZH90E9

		Base type	Additional type	Base type	Additional type	Base type	Additional type	Base type	Additional type	Base type	Additional type	Base type	Additional type
Specifications	Model	GX270											
	Type	Standard equipment (1)											
			QXE8/A (QXE8)	QXE9	QXC9/A (QXC9)	QXK	VPE7/A (VPE7)	VPK	VS3	VS4	VXE7/A (VXE7)	VXE8	VXQ4/A (VXQ4)
Crankshaft	25mm Ø Straight												
	25.4mm Ø Straight	●	●	●	●								
	20mm Ø Spline												
	M20 Stepped thread												
	1" Thread												
	M10 Tapered												
	5/16" Tapered					●	●	●	●	●	●	●	●
Reduction	1/2 Reduction												
	1/2 Reduction (With clutch)												
	1/6 Reduction												
Coil	Lamp coil												
	Charge coil	●	●			●	●			●	●		
Fuel tank		●	●	●	●					●	●	●	●
Control box		●	●							●	●		
Starter motor		●	●			●	●			●	●		
Oil alert		●	●	●	●	●	●	●	●	●	●	●	●

NOTE A:PART NO. CHANGE D:NEWLY PROVIDED E:PART NO.DELETION K:REQUIRED NO. CORRECTION L:APPLICATION SERIAL NO. CORRECTION
T:APPLICATION CORRECTION Z:REMARKS CHANGE

PARTS CATALOGUE NEWS

BOOKNo. : 13ZH90E9

Block No.	Ref. No.	Part No.	Description	Reqd. QTY			Base Part No.	Parts catalogue code
				(1)	GX270 (2)	(3)		
E-2	17	98079-55846	PLUG, SPARK (BPR5ES) (NGK)	1	-	-	98079-55846	VPK
				(1)	-	-		VXK
E-6	2	11300-ZE2-602	COVER ASSY., CRANKCASE	1	-	-	11300-ZK9-U60	VXE8
		11300-ZK9-U60	1	-	-	11300-ZE2-602	VPK
	9	16510-ZE2-000	GOVERNOR ASSY.	0	-	-	16510-ZE2-000	VPK
		16510-ZE2-000	1	-	-		VXE8
	10	16511-ZE2-000	WEIGHT, GOVERNOR	0	-	-	16511-ZE2-000	VPK
		16511-ZE2-000	2	-	-		VXE8
	11	16512-ZE2-000	HOLDER, GOVERNOR WEIGHT	0	-	-	16512-ZE2-000	VPK
		16512-ZE2-000	1	-	-		VXE8
	12	16513-ZE2-000	PIN, GOVERNOR WEIGHT	2	-	-	16513-ZE2-000	VXE8
				3	-	-		VPK
	14	90473-147-000	WASHER, 6X16	0	-	-	90473-147-000	VXE8
				1	-	-		VPK
	23	16510-ZE3-000	GOVERNOR ASSY.	0	-	-	16510-ZE3-000	VXE8
				1	-	-		VPK
24	16511-ZE8-000	WEIGHT, GOVERNOR	0	-	-	16511-ZE8-000	VXE8	
			3	-	-		VPK	
25	16512-ZE3-000	HOLDER, GOVERNOR WEIGHT	0	-	-	16512-ZE3-000	VXE8	
			1	-	-		VPK	
E-7	6	13310-ZH9-671	CRANKSHAFT COMP.	1	-	-	13310-ZK9-800	VXE8
		13310-ZH9-841	1	-	-	13310-ZK9-670	VPK
E-9	1	14100-ZE3-020	CAMSHAFT ASSY.	1	-	-	14100-ZK3-870	VXE8
		14100-ZH9-010	1	-	-	14100-ZK9-870	VPK

NOTE A:PART NO. CHANGE D:NEWLY PROVIDED E:PART NO.DELETION K:REQUIRED NO. CORRECTION L:APPLICATION SERIAL NO. CORRECTION
T:APPLICATION CORRECTION Z:REMARKS CHANGE

PARTS CATALOGUE NEWS

BOOKNo. : 13ZH90E9

Block No.	Ref. No.	Part No.	Description	Reqd. QTY			Base Part No.	Parts catalogue code
				(1)	(2)	(3)		
E-11	1		STARTER ASSY., RECOIL *R280*..... POWER RED	0	-	-	28400-ZE2-W01ZN	VS4
	2		CASE COMP., RECOIL STARTER *R280*..... POWER RED	0	-	-	28410-ZE2-W01ZN	VS4
E-12	5		COVER COMP., FAN *R8*..... BRIGHT RED	0	-	-	19610-ZE2-010ZA	VXE8
			R280..... POWER RED	0	-	-	19610-ZH9-D40ZC	VS4
		19610-ZE2-010ZF	*NH246*..... LOOSEY GRAY	1	-	-		QXK
	11	36100-ZH7-003	SWITCH ASSY., ENGINE STOP	1	-	-	36100-ZH7-W41	VXK
	22		CLIP, HARNESS	0	-	-	90684-ZA0-601	QXK, VXK
E-14-1	8	16100-Z5H-V02	CARBURETOR ASSY. (BE21F B) ...	1	-	-	16100-ZH9-V02	VPK
	16	16260-ZE3-D21	STAY ASSY., MANUAL CHOKE	1	-	-	16260-ZE2-722	VPK
	25	16611-ZE3-D21	ROD, CHOKE CONTROL	1	-	-	16611-ZE2-711	VPK
E-15-2	1	16271-ZE2-010	PACKING, ELBOW	1	-	-		VXE8
	2	17210-ZE2-822	ELEMENT, AIR CLEANER (DUAL) ..	1	-	-		VXE8
	3	17218-ZE2-821	FILTER, OUTER	1	-	-		VXE8
	5	17231-ZH9-820	COVER, AIR CLEANER	1	-	-		VXE8
	6	17232-891-000	GROMMET, AIR CLEANER	1	-	-		VXE8
	7	17238-ZE2-310	COLLAR, AIR CLEANER	2	-	-		VXE8
	8	17239-ZE1-000	COLLAR B, AIR CLEANER	1	-	-		VXE8
	9	17410-ZE2-020	ELBOW COMP., AIR CLEANER	1	-	-		VXE8
	12	90325-044-000	NUT, TOOL BOX SETTING	2	-	-		VXE8
	13	90009-ZE2-003	BOLT-WASHER, 6X22	1	-	-		VXE8
	14	94050-06000	NUT, FLANGE, 6MM	2	-	-		VXE8
	15	17235-ZE2-820	NOSE, SILENCER	1	-	-		VXE8, VXK
E-15-4	1		PACKING, ELBOW	0	-	-	16271-ZE2-010	VXE8

NOTE A:PART NO. CHANGE D:NEWLY PROVIDED E:PART NO.DELETION K:REQUIRED NO. CORRECTION L:APPLICATION SERIAL NO. CORRECTION
T:APPLICATION CORRECTION Z:REMARKS CHANGE

PARTS CATALOGUE NEWS

BOOKNo. : 13ZH90E9

Block No.	Ref. No.	Part No.	Description	Reqd. QTY			Base Part No.	Parts catalogue code
				(1)	GX270 (2)	(3)		
	2		ELEMENT, AIR CLEANER	0	-	-	17210-ZE3-010	VXE8
	3		FILTER, OUTER	0	-	-	17218-ZE3-000	VXE8
	4		COVER, AIR CLEANER (100DB) ...	0	-	-	17231-ZH9-N01	VXE8
	5		GROMMET, AIR CLEANER	0	-	-	17232-891-000	VXE8
	6		NOSE, SILENCER	0	-	-	17235-ZH9-N01	VXE8
	7		COLLAR, AIR CLEANER	0	-	-	17238-ZE2-310	VXE8
	8		COLLAR B, AIR CLEANER	0	-	-	17239-ZE1-000	VXE8
	9		ELBOW COMP., AIR CLEANER	0	-	-	17410-ZH9-N00	VXE8
	12		NUT, TOOL BOX SETTING	0	-	-	90325-044-000	VXE8
	13		BOLT-WASHER, 6X22	0	-	-	90009-ZE2-003	VXE8
	14		NUT, FLANGE, 6MM	0	-	-	94050-06000	VXE8
E-16-1	1		COLLAR, AIR CLEANER CASE	(0)	-	-	17233-896-701	VXK
	3		PROTECTOR COMP., MUFFLER (100DB)	0	-	-	18320-ZF6-W01	VXE8
		18320-ZE2-W61	PROTECTOR COMP., MUFFLER	1	-	-		VXE8
	8	18355-ZE2-W00	ARRESTER, SPARK	(1)	-	-	18355-ZE2-W00	VXE8
	9	18381-ZE2-W10	GASKET, MUFFLER (ARRESTER) ...	(1)	-	-	18381-ZE2-W10	VXE8
	10	18381-Z1C-801	GASKET, MUFFLER	1	-	-		VXE8
		18381-Z1C-801	1	-	-	18381-ZE2-800	QXE9, QXK, VXK
	12		COVER COMP., MUFFLER	(0)	-	-	18433-ZF6-W40	VXK
	13		COVER COMP., MUFFLER RR.	(0)	-	-	18434-ZF6-W40	VXK
	14		BASE COMP., MUFFLER COVER	(0)	-	-	18436-ZH8-W40	VXK
	15		STAY, MUFFLER COVER	(0)	-	-	18437-ZF6-W40	VXK
	16		PLATE, SET	(0)	-	-	18438-ZF6-W40	VXK
	17		SPACER, MUFFLER COVER	(0)	-	-	18466-ZH8-W40	VXK

NOTE A:PART NO. CHANGE D:NEWLY PROVIDED E:PART NO.DELETION K:REQUIRED NO. CORRECTION L:APPLICATION SERIAL NO. CORRECTION
T:APPLICATION CORRECTION Z:REMARKS CHANGE

PARTS CATALOGUE NEWS

BOOKNo. : 13ZH90E9

Block No.	Ref. No.	Part No.	Description	Reqd. QTY			Base Part No.	Parts catalogue code
				(1)	(2)	(3)		
	19	90050-ZE1-000	SCREW, TAPPING, 5X8	4	-	-	90050-ZE1-000	VXE8
	20		SCREW, TAPPING, 5X8	(0)	-	-	90050-ZE1-000	VXK
	21		SCREW, TAPPING, 5X25	(0)	-	-	90050-ZH8-W40	VXK
	23		NUT, HEX., 5MM	(0)	-	-	90302-KF9-900	VXK
	24		SCREW-WASHER, 5X12	(0)	-	-	93891-05012-00	VXK
	25		SCREW-WASHER, 6X20	(0)	-	-	93891-06020-07	VXK
	28		WASHER, PLAIN, 5MM	(0)	-	-	94103-05700	VXK
	29		WASHER, SPRING, 5MM	(0)	-	-	94111-05000	VXK
	30		WASHER, SPRING, 5MM	(0)	-	-	94111-05000	VXK
	31	90055-ZE1-000	SCREW, TAPPING, 4X6	(1)	-	-	90050-ZE1-000	VXE8

E-17 FUEL TANK (1)

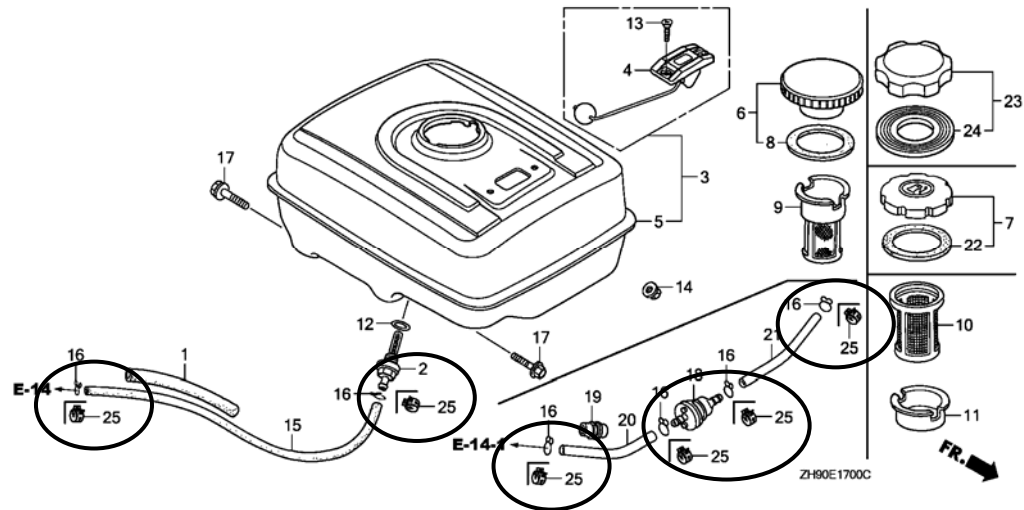

E-17	15	91424-Z5F-801	TUBE, FUEL, 4. 5X222 (FKM)	1	-	-	95001-45222-40	QXK, VXE8
	16		CLIP, TUBE (B8)	0	-	-	95002-02080	QXK, VPK, VXE8

NOTE A:PART NO. CHANGE D:NEWLY PROVIDED E:PART NO.DELETION K:REQUIRED NO. CORRECTION L:APPLICATION SERIAL NO. CORRECTION
T:APPLICATION CORRECTION Z:REMARKS CHANGE

PARTS CATALOGUE NEWS

BOOKNo. : 13ZH90E9

Block No.	Ref. No.	Part No.	Description	Reqd. QTY			Base Part No.	Parts catalogue code
				(1)	GX270 (2)	(3)		
	20	91424-Z5J-801	TUBE, FUEL, 4.5X120(FKM)	1	-	-	95001-45120-40	VPK
	21	91424-Z4J-801	TUBE, FUEL, 4.5X150(FKM)	1	-	-	95001-45150-40	VPK
	25	95002-40800-08	CLAMP, TUBE (D8)	2	-	-		QXK, VXE8
				4	-	-		VPK
E-20	18	90684-ZA0-601	CLIP, HARNESS	1	-	-		QXK
E-22	3	16561-ZE2-000	SPRING, GOVERNOR	1	-	-	16561-ZH9-U30	VXE8
		16561-ZK9-800	1	-	-	16561-ZE2-000	VPK
	5		CONTROL ASSY.	0	-	-	16570-ZE2-W00	VXK
	9	16570-ZE2-722	CONTROL ASSY.	1	-	-		VXK
	10		LEVER, CONTROL	0	-	-	16571-ZE2-W00	VXK
	11		SPRING, LEVER	0	-	-	16574-ZE1-000	VXK
	12		WASHER, CONTROL LEVER	0	-	-	16575-ZE2-W00	VXK
	15		SPACER, CONTROL LEVER	0	-	-	16578-ZE1-000	VXK
	16		BASE COMP., CONTROL (###)	0	-	-	16581-ZE2-W00	VXK
	22		COLLAR, STOPPER	(0)	-	-	16599-ZG1-M10	VXK
	26		SCREW, RECESSED, 5X25	(0)	-	-	90016-ZG9-N30	VXK
	27		NUT, SELF-LOCK, 6MM	0	-	-	90114-SA0-000	VXK
	32		SCREW, PAN, 5X28	0	-	-	93500-05028-0A	VXK
	37	93500-05035-0A	SCREW, PAN, 5X35	1	-	-		VXK
E-23-1	2		BOX ASSY., CONTROL (EXTERNAL-ALERT)				31610-ZH9-W52ZB	
			NH1..... BLACK	0	-	-		VXE8
			BOX ASSY., CONTROL (ALERT)				31610-ZH9-W52ZC	
			R280..... POWER RED	0	-	-		VXE8
		31610-Z5K-801ZA	BOX ASSY., CONTROL (EXP-ALERT)					
			R280..... POWER RED	1	-	-		VXE8

NOTE A:PART NO. CHANGE D:NEWLY PROVIDED E:PART NO.DELETION K:REQUIRED NO. CORRECTION L:APPLICATION SERIAL NO. CORRECTION
T:APPLICATION CORRECTION Z:REMARKS CHANGE

PARTS CATALOGUE NEWS

BOOKNo. : 13ZH90E9

Block No.	Ref. No.	Part No.	Description	Reqd. QTY			Base Part No.	Parts catalogue code
				(1)	GX270 (2)	(3)		
		31610-Z5K-801ZB	*NH1*..... BLACK	1	-	-	VXE8	
	11	35111-880-013	KEY COMP.	2	-	-	35111-880-003	QXE9, VXE8
	15	87529-Z4T-840	MARK, CONTROL BOX (EXTERNAL) .	1	-	-	87529-ZH9-W41	VXE8

E-28 LABEL (1)

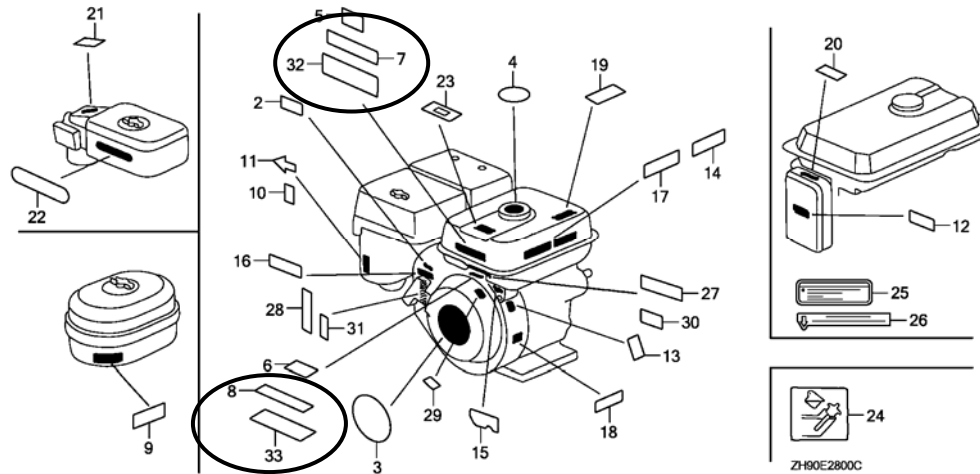

E-28	3		EMBLEM	0	-	-	87521-ZH9-030	VS4
	5		MARK, CAUTION (PICTOGRAPH) ...	0	-	-	87522-ZH8-W41	VXE8, VXK
	7		LABEL, CAUTION (ENGLISH, ETC.)	0	-	-	87522-ZH9-010	QXE9
	10	87528-ZE2-810	MARK, CHOKE (ORANGE)	1	-	-	87528-ZF6-W40	VXK
		87528-ZH7-000	MARK, CHOKE (GRAY)	1	-	-		QXK
		87528-ZH7-000	1	-	-	87528-ZF6-W40	VXE8
	16		MARK, THROTTLE INDICATION	0	-	-	87532-ZH8-W40	VXK
		87532-ZH7-000	1	-	-	87532-ZH8-W40	QXK, VXE8
	17		MARK, OIL ALERT (EXTERNAL) ...	0	-	-	87532-ZH8-810	QXE9, QXK

NOTE A:PART NO. CHANGE D:NEWLY PROVIDED E:PART NO.DELETION K:REQUIRED NO. CORRECTION L:APPLICATION SERIAL NO. CORRECTION
T:APPLICATION CORRECTION Z:REMARKS CHANGE

PARTS CATALOGUE NEWS

BOOKNo. : 13ZH90E9

Block No.	Ref. No.	Part No.	Description	Reqd. QTY			Base Part No.	Parts catalogue code
				(1)	(2)	(3)		
	21		LABEL, AIR CLEANER CAUTION ...	0	-	-	87534-ZE1-841	QXK
	22	87535-ZE1-841	MARK, AIR CLEANER SALES POINT	1	-	-	87535-ZE1-840	QXK
	31	87114-ZH7-000	LABEL, WARNING (NOT CERTIFIED FOR SALE)	1	-	-		QXE9, VXK
	32	87516-ZM7-801	MARK, OPERATOR CAUTION	1	-	-		QXK, VXE8
	33	87516-ZM7-801	MARK, OPERATOR CAUTION	1	-	-		VPK
E-29	21	98079-55846	PLUG, SPARK (BPR5ES) (NGK)	(1)	-	-	98079-55846	VS4

E-40-10 OTHER PARTS

(EMERGENCY STOP SWITCH)

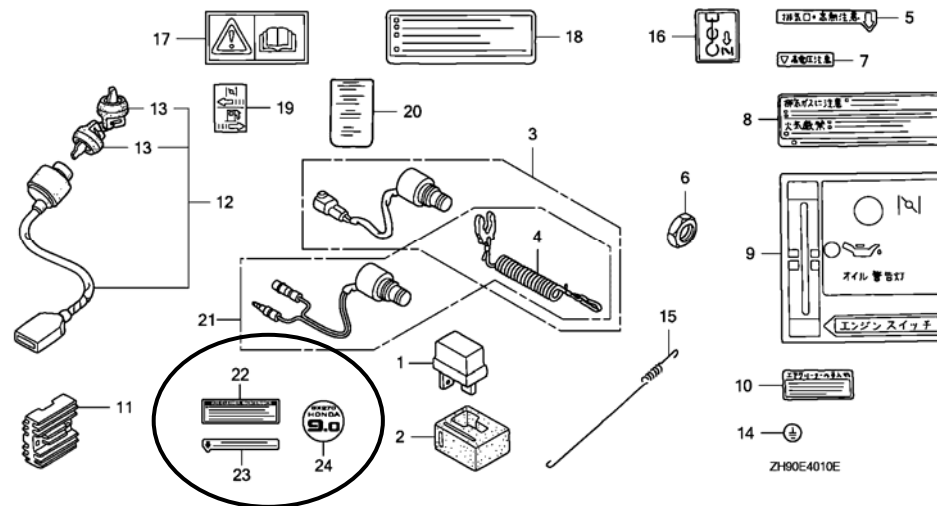

E-40-10	15		SPRING, GOVERNOR	0	-	-	16561-ZE2-A00	VXE8
	16	87528-898-620	MARK, CHOKE	1	-	-		VPK
	17		MARK, CAUTION (PICTOGRAPH) ...	0	-	-	87522-ZH8-W41	QXK
	19		MARK, CHOKE (ORANGE)	0	-	-	87528-ZE2-810	QXK
			MARK, CHOKE (GRAY)	0	-	-	87528-ZH7-000	QXK

NOTE A:PART NO. CHANGE D:NEWLY PROVIDED E:PART NO.DELETION K:REQUIRED NO. CORRECTION L:APPLICATION SERIAL NO. CORRECTION
T:APPLICATION CORRECTION Z:REMARKS CHANGE

PARTS CATALOGUE NEWS

BOOKNo. : 13ZH90E9

Block No.	Ref. No.	Part No.	Description	Reqd. QTY			Base Part No.	Parts catalogue code
				(1)	GX270 (2)	(3)		
		87528-ZE2-810	MARK, CHOKE (ORANGE)	1	-	-	QXE9, VXK	
	24	87521-ZH9-030	EMBLEM	1	-	-	VS4	

NOTE A:PART NO. CHANGE D:NEWLY PROVIDED E:PART NO.DELETION K:REQUIRED NO. CORRECTION L:APPLICATION SERIAL NO. CORRECTION
T:APPLICATION CORRECTION Z:REMARKS CHANGE



PARTS CATALOGUE NEWS

Honda Motor Co., Ltd. Service Division

PARTS CATALOGUE - CORRECTED

Printed in Japan

CODE NO.	BOOKLET TYPE	13ZH90E9
	MICRO- FICHE	13ZH90EI/FI
PARTS CATALOGUE NEWS	GX270 GX270[PROPANE ENGINE]	
NEWS NO.	005	

Block No.	Ref. No.	Note	Part No.	Description	Reqd. QTY			Serial No.	Parts catalogue code
					(1)	GX270 (2)	(3)		
E-7	5		13310-ZH9-650	CRANKSHAFT COMP.	1	-	-	-----	PX, PXE8, PXU, PX26
					1	-	-	-----	2401132
	A	13310-ZH9-651	1	-	-	2401133	-----	PX/A, PXE8/A, PXU/A, PX26/A
	14		13310-ZH9-700	CRANKSHAFT COMP.	1	-	-	-----	ESS, ES1, ES3, VMT
					1	-	-	-----	2395177
A	13310-ZH9-701	1	-	-	2395178	-----	ESS/A, ES1/A, ES3/A, VMA4, VME4, VMT/A	
E-28	32	T	87516-ZM7-801	MARK, OPERATOR CAUTION	1	-	-	-----	QXE9, QXK, VXE8, VXK
	33	T	87516-ZM7-801	MARK, OPERATOR CAUTION	1	-	-	-----	VPK, VS4

NOTE A:PART NO. CHANGE D:NEWLY PROVIDED E:PART NO.DELETION K:REQUIRED NO. CORRECTION L:APPLICATION SERIAL NO. CORRECTION
T:APPLICATION CORRECTION Z:REMARKS CHANGE



PARTS CATALOGUE NEWS

Honda Motor Co., Ltd. Service Division

Printed in Japan

CODE NO.	BOOKLET TYPE	13ZH90E9
	MICRO- FICHE	13ZH90EI/FI
PARTS CATALOGUE NEWS	GX270 GX270[PROPANE ENGINE]	
NEWS NO.	006	

GX270-VKK TYPE sales parts information

NOTE: This Parts Catalogue News explains only the parts of the different model that are produced to conform to addition of the GX270-VKK type.

As for the parts not listed on this Parts Catalogue News, use the parts of the GX270-VKE4 type.

•Models, parts catalogue codes and applicable serial numbers

Model	Type		Parts catalogue type	Applicable engine serial No.	Applicable carburetor identification No.
GX270	VKE4	Base model	VKE4	GCAB- 2000001~9999999	BE21E B / C
	VKK	Additional model	VKK	GCAB- 2000001~	BE21G B

•Features of each type		Base type	Additional type
Specifications		Model	GX270
		Type	Standard equipment (1)
		VKE4	VKK
Crankshaft	25mm Ø Straight		
	25.4mm Ø Straight		
	20mm Ø Spline		
	M20 Stepped thread		
	1" Thread		
	M10 Tapered		
	5/16" Tapered	●	●
Reduction	1/2 Reduction		
	1/2 Reduction (With clutch)		
	1/6 Reduction		
Coil	Lamp coil		
	Charge coil	●	●
Fuel tank			
Control box			
Starter motor		●	●
Oil alert		●	●

PARTS CATALOGUE NEWS

BOOKNo. : 13ZH90E9

Block No.	Ref. No.	Part No.	Description	Reqd. QTY			Base Part No.	Parts catalogue code
				(1)	(2)	(3)		
E-2	1	12200-ZH9-405	HEAD COMP., CYLINDER	1	-	-	12200-ZH9-000	
E-3	1	12000-ZH9-407	BARREL ASSY., CYLINDER (SELFSTARTER+ALERT)	1	-	-	12000-ZH9-812	
E-14-1	8	16100-Z5J-V12	CARBURETOR ASSY. (BE21G B) ...	1	-	-	16100-ZH9-V12	

E-16-4 MUFFLER (5)

Ref. No.	(Relative ref. Number)	Description	FRT
10 3131A1		ARRESTER, SPARK	0.2
		. INCLUDES: Spark arrester check	

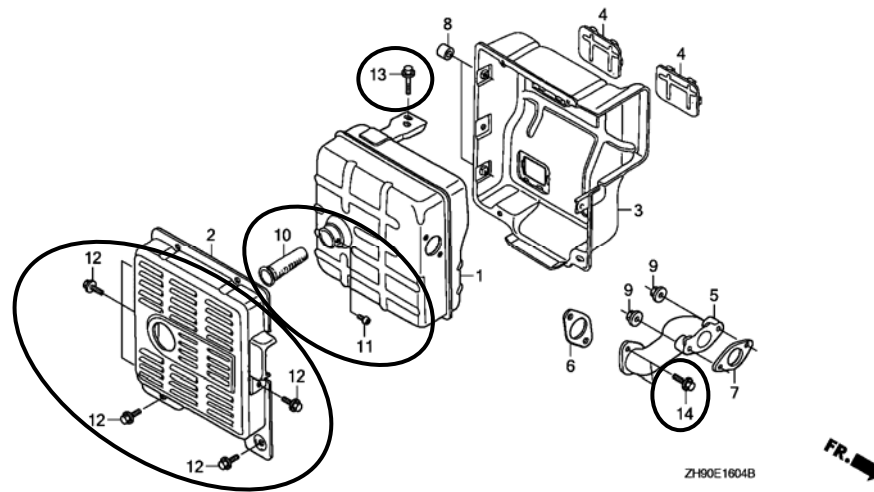

E-16-4	10	18355-ZB4-630	ARRESTER, SPARK	1	-	-		
	11	90002-ZE2-U91	SCREW, TAPPING, 4X8	1	-	-		
	12	95701-06012-00	BOLT, FLANGE, 6X12	8	-	-		
	13	95701-08016-08	BOLT, FLANGE, 8X16	2	-	-		
	14	95701-08020-08	BOLT, FLANGE, 8X20	2	-	-		
E-17	16		CLIP, TUBE (B8)	0	-	-	95002-02080	
	20	91424-Z5J-801	TUBE, FUEL, 4.5X120 (FKM)	1	-	-	95001-45120-40	
	21	91424-Z4J-801	TUBE, FUEL, 4.5X150 (FKM)	1	-	-	95001-45150-40	

PARTS CATALOGUE NEWS

BOOKNo. : 13ZH90E9

Block No.	Ref. No.	Part No.	Description	Reqd. QTY			Base Part No.	Parts catalogue code
				(1)	(2)	(3)		
	25	95002-40800-08	CLAMP, TUBE (D8)	4	-	-		
E-23-1	6		RECTIFIER ASSY., SILICON (SHINDENGEN)	0	-	-	31700-124-008	
	7		SUSPENSION, COUPLER	0	-	-	32127-738-700	
	10		SWITCH ASSY., COMBINATION (3A-CHARGE)	0	-	-	35100-ZE2-842	
	11		KEY COMP.	0	-	-	35111-880-003	
	25		FUSE, BLADE (15A)	0	-	-	98200-31500	
E-28	31	87114-ZH7-000	LABEL, WARNING (NOT CERTIFIED FOR SALE)	1	-	-		
	33	87516-ZM7-801	MARK, OPERATOR CAUTION	1	-	-		

E-40-10 OTHER PARTS

(EMERGENCY STOP SWITCH)

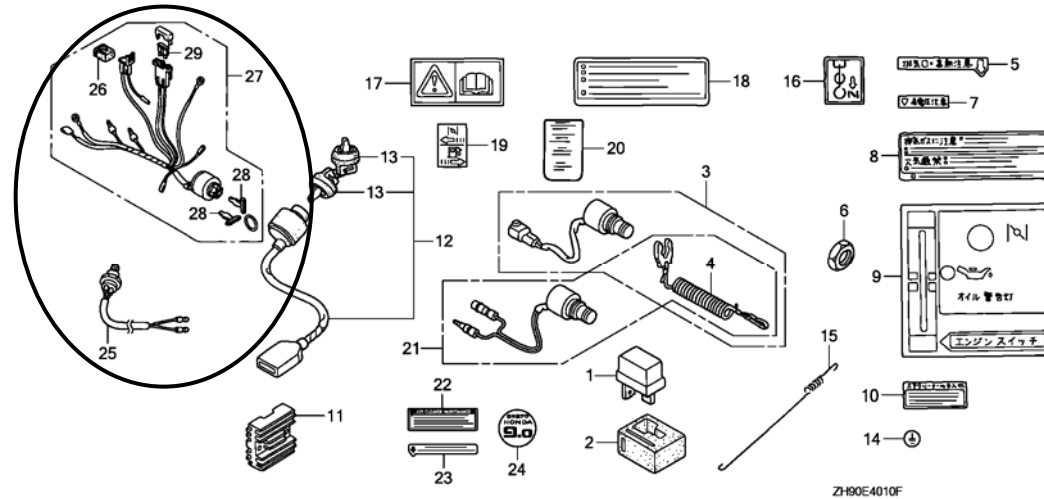

ZH90E4010F

E-40-10	1	31700-124-008	RECTIFIER ASSY., SILICON (SHINDENGEN)	1	-	-		
	16	87528-898-620	MARK, CHOKE	1	-	-		

PARTS CATALOGUE NEWS

BOOKNo. : 13ZH90E9

Block No.	Ref. No.	Part No.	Description	Reqd. QTY			Base Part No.	Parts catalogue code
				(1)	GX270 (2)	(3)		
	24	87521-ZH9-030	EMBLEM	1	-	-		
	25	16500-ZE2-702	SWITCH, THERMO	1	-	-		
	26	32127-738-700	SUSPENSION, COUPLER	1	-	-		
	27	35100-ZE2-842	SWITCH ASSY., COMBINATION (3A-CHARGE)	1	-	-		
	28	35111-880-013	KEY COMP.	2	-	-		
	29	98200-31500	FUSE, BLADE (15A)	1	-	-		



PARTS CATALOGUE NEWS

Honda Motor Co., Ltd. Service Division

PARTS CATALOGUE - CORRECTED

Printed in Japan

CODE NO.	BOOKLET TYPE	13ZH90E9
	MICRO-FICHE	13ZH90EI/FI
PARTS CATALOGUE NEWS	GX270 GX270[PROPANE ENGINE]	
NEWS NO.	007	

Block No.	Ref. No.	Note	Part No.	Description	Reqd. QTY GX270 (1) (2) (3)	Serial No.	Parts catalogue code
-----------	----------	------	----------	-------------	-----------------------------------	------------	----------------------

E-16-3 MUFFLER (4)

Ref. No.	(Relative ref. Number)	Description	FRT
4	(5, 24)	GASKET, EXHAUST PIPE	0.2

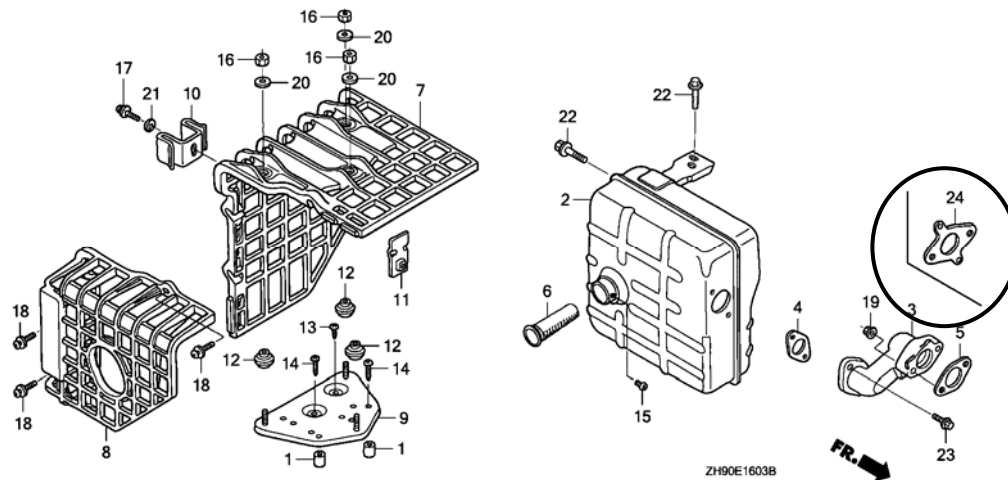

NOTE A:PART NO. CHANGE D:NEWLY PROVIDED E:PART NO.DELETION K:REQUIRED NO. CORRECTION L:APPLICATION SERIAL NO. CORRECTION
T:APPLICATION CORRECTION Z:REMARKS CHANGE

PARTS CATALOGUE NEWS

BOOKNo. : 13ZH90E9

Block No.	Ref. No.	Note	Part No.	Description	Reqd. QTY			Serial No.	Parts catalogue code
					(1)	(2)	(3)		
E-16-3	5	L	18333-ZE3-800	GASKET, EX. PIPE	1	-	-	-----	VPE4, VPE4/A, VPE7, VPE7/A, VPX4, VPX4/A, VPX7, VPX7/A, VSD3 VSD3/A, VS37, VS37/A
					1	-	-	-----	2425148
	24	D	18333-ZF6-W01	GASKET, EX. PIPE	1	-	-	2425149	VPK

E-16-4 MUFFLER (5)

Ref. No.	(Relative ref. Number)	Description	FRT
6	(7, 15)	GASKET, EXHAUST PIPE	0.2

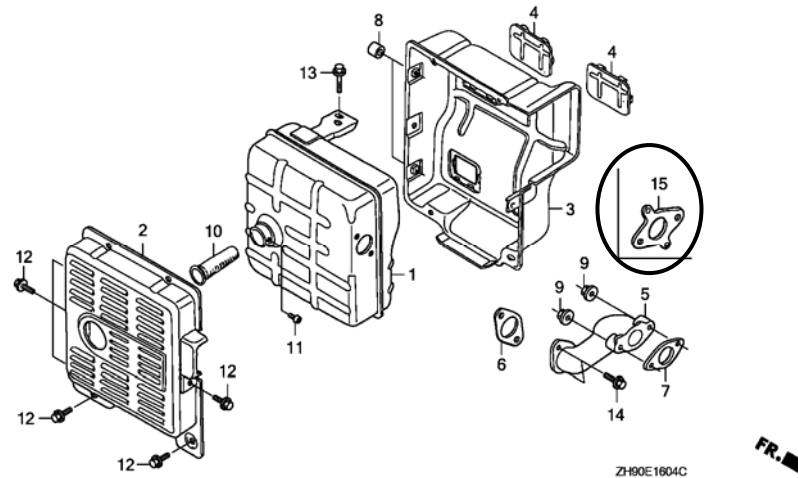

E-16-4	7	L	18333-ZE3-800	GASKET, EX. PIPE	1	-	-	-----	ES3, VKE4, VKK, VKX4, VMT
					1	-	-	-----	2425148
	15	D	18333-ZF6-W01	GASKET, EX. PIPE	1	-	-	2425149	ES3/A, VMT/A, VS3, VS4
E-26	22		91202-805-610	OIL SEAL (PJ30507)	1	1	1	-----	RA, RA2, RA2/A, RD, RH, RHE, RHE4, RHE4/A, RHQ4, RHQ4/A, RH26 RH26/A, RSC2, RSC2/A, RSS, RX, RXP, RXP/A, RXQ4, RXQ4/A, RXU RXU/A, R1
					1	1	-	-----	2425806
	A	91202-Z2F-801	OIL SEAL, 30X50X7	1	1	-	2425807	RD/A, RSS/A, RX/A, R1/A	

NOTE A:PART NO. CHANGE D:NEWLY PROVIDED E:PART NO.DELETION K:REQUIRED NO. CORRECTION L:APPLICATION SERIAL NO. CORRECTION T:APPLICATION CORRECTION Z:REMARKS CHANGE



PARTS CATALOGUE NEWS

Honda Motor Co., Ltd. Service Division

PARTS CATALOGUE - CORRECTED

Printed in Japan

CODE NO.	BOOKLET TYPE	13ZH90E9
	MICRO- FICHE	13ZH90EI/FI
PARTS CATALOGUE NEWS	GX270 GX270[PROPANE ENGINE]	
NEWS NO.	008	

Block No.	Ref. No.	Note	Part No.	Description	Reqd. QTY			Serial No.	Parts catalogue code
					(1)	GX270 (2)	(3)		
E-28	31	T	87114-ZH7-000	LABEL, WARNING (NOT CERTIFIED FOR SALE)	1	1	-	2359274 -----	HX/A, LHB5, LJ/A, LJC/A, LJG/A, LT/A, LWD1/A, LX/A, L1/A, PX/A QAB3/A, QD/A, QHB5, QHP1/A, QHZ/A, QMH/A, QP/A, QT/A, QX/A QXE/A, Q1/A, RD/A, RSS/A, RX/A, R1/A, SD/A, SJG/A, SN/A, SX/A SXE/A, S1/A, VMT/A, VX/A, VXT1/A, W1/A
					1	-	-	-----	QXE9, QXK, VKK, VPK, VS4, VXE8, VXK
					1	-	-	2397962 -----	VS3
					1	-	-	2401383 -----	ESS/A, ES1/A, ES3/A, LH/A, LHE/A, LW/A, LXE/A, QH/A, QSE/A SH/A, SJ/A, VXU/A, WMT8/A, WXE8/A

NOTE A:PART NO. CHANGE D:NEWLY PROVIDED E:PART NO.DELETION K:REQUIRED NO. CORRECTION L:APPLICATION SERIAL NO. CORRECTION
T:APPLICATION CORRECTION Z:REMARKS CHANGE



PARTS CATALOGUE NEWS

Honda Motor Co., Ltd. Service Division

PARTS CATALOGUE - CORRECTED

Printed in Japan

CODE NO.	BOOKLET TYPE	13ZH90E9
	MICRO- FICHE	13ZH90EI/FI
PARTS CATALOGUE NEWS	GX270 GX270[PROPANE ENGINE]	
NEWS NO.	009	

Block No.	Ref. No.	Note	Part No.	Description	Reqd. QTY			Serial No.	Parts catalogue code
					(1)	(2)	(3)		
E-7	3		13310-ZH9-820	CRANKSHAFT COMP.	1	-	1	-----	HA, HAP, HAQ, HA2, HA2/A, HEA, HEA2, HEA2/A, HEA8, HEA8/A, LSS LTJ, LWD1, LWD1/A
					-	-	1	-----	1100192 HAP/A
		A	13310-ZH9-821	-	-	1	1100193	-----
E-17	5	T	17510-ZE3-010ZA	TANK COMP., FUEL *NH31*..... MCKINLEY WHITE	1	-	-	-----	RSS
		D	17510-ZE3-020ZA	*NH31*..... MCKINLEY WHITE	1	-	-	-----	2423431 RSS/A
		A	17510-ZE3-800ZC	*NH31*..... MCKINLEY WHITE	1	-	-	2423432	-----

NOTE A:PART NO. CHANGE D:NEWLY PROVIDED E:PART NO.DELETION K:REQUIRED NO. CORRECTION L:APPLICATION SERIAL NO. CORRECTION
T:APPLICATION CORRECTION Z:REMARKS CHANGE



PARTS CATALOGUE NEWS

Honda Motor Co., Ltd. Service Division

PARTS CATALOGUE - CORRECTED

Printed in Japan

CODE NO.	BOOKLET TYPE	13ZH90E9
	MICRO-FICHE	13ZH90EI/FI
PARTS CATALOGUE NEWS	GX270 GX270[PROPANE ENGINE]	
NEWS NO.	010	

Block No.	Ref. No.	Note	Part No.	Description	Reqd. QTY			Serial No.	Parts catalogue code
					(1)	(2)	(3)		
E-19	8		90201-ZE3-V00	NUT, SPECIAL, 16MM	1	1	-	----- 2432845	ESS/A, ES1/A, ES3/A, HX/A, LH/A, LHB5, LHE/A, LJ/A, LJG/A, LT/A, LW/A, LWD1/A, LX/A, LXE/A, L1/A, PX/A, QAB3/A, QD/A, QH/A, QHB5, QHP1/A, QHZ/A, QMH/A, QP/A, QSE/A, QT/A, QX/A, QXE/A, QXE9, QXK, Q1/A, RD/A, RSS/A, RX/A, R1/A, SD/A, SH/A, SJ/A, SJG/A, SN/A, SX/A, SXE/A, S1/A, VKK, VMT/A, VPK, VS3, VS4, VX/A, VXE8, VXX, VXT1/A, VXU/A, WMT8/A, WXE8/A, W1/A
					1	1	-	1180428 -----	ESS, HA, HAQ, HA2, HEA, HEA2, HH, HX, HXQ4, HX26, LH, LHE, LHQ4, LJ, LJG, LSS, LTJ, LW, LWD, LX, LXE, LXQ4, LXZ, LX16, L1, PA, PA2, PX, PX26, QA, QAE, QAE2, QAE6, QAQ, QAQ4, QAR2, QA2, QD, QE, QH, QHC, QHE, QHE4, QHQ4, QH26, QME2, QP, QSC, QSC9, QT, QX, QXB, QXC, QXC4, QXC6, QXC9, QXE, QXEB, QXE4, QXE6, QXQ4, QX26, Q1, Q2, RA, RA2, RD, RH, RHE, RHE4, RHQ4, RH26, RSC2, RX, RXQ4, R1, SD, SE, SH, SHE, SHEZ, SHQ4, SJ, SJG, SJP, SK, SMC4, SME1, SME6, SN, SW, SWE, SX, SXB, SXE, SXEB, SXE4, SXQ4, SX2, S1, VA, VAW, VAW1, VA2, VDE, VD16, VEB6, VH, VNG1, VSD, VSD3, VWA, VWA2, VWN2, VW12, VW22, VXXB, VXB2, VXB6, VXE, VXEB, VXE4, VXG, VXQ4, VXU, VX26, V1, W1

NOTE A:PART NO. CHANGE D:NEWLY PROVIDED E:PART NO.DELETION K:REQUIRED NO. CORRECTION L:APPLICATION SERIAL NO. CORRECTION
T:APPLICATION CORRECTION Z:REMARKS CHANGE

PARTS CATALOGUE NEWS

BOOKNo. : 13ZH90E9

Block No.	Ref. No.	Note	Part No.	Description	Reqd. QTY			Serial No.	Parts catalogue code	
					(1)	(2)	(3)			
					1	-	1	-----	ES1, ES3, HAP, HAP/A, HA2/A, HEA2/A, HEA8, HEA8/A, HXQ4/A, HX26/A, HX8, HX8/A, LHB1, LHB3, LJC, LJC/A, LT, LWD1, LXE8, LXE8/A, LXQ4/A, LXU, LXU/A, PAE2, PAE2/A, PA2/A, PXE8, PXE8/A, PXU, PXU/A, PX26/A, QAB1, QAB3, QAE2/A, QAE6/A, QAG, QAG/A, QAG2, QAG2/A, QAQ4/A, QAR2/A, QAW, QAW/A, QA2/A, QE/A, QHE4/A, QHP1, QHQ4/A, QHR, QHR/A, QHR4, QHR4/A, QHZ, QH26/A, QKE3, QKE3/A, QKE4, QL2, QME2/A, QMH, QSC9/A, QSE, QSE2, QSE8, QSE8/A, QWA2, QWA4, QWA4/A, QWH2, QWH2/A, QXB/A, QXB6, QXB6/A, QXB7, QXB7/A, QXC4/A, QXC6/A, QXC9/A, QXE4/A, QXE6/A, QXE8, QXE8/A, QXQ4/A, QXU, QXU/A, QX26/A, RA2/A, RHE4/A, RHQ4/A, RH26/A, RSC2/A, RSS, RXP, RXP/A, RXQ4/A, RXU, RXU/A, SE/A, SHQ4/A, SKE1, SMC4/A, SMD, SME1/A, SME6/A, SMX2, SWA4, SWC4, SWC4/A, SXB/A, SXB7, SXB7/A, SXEB/A, SXE4/A, SXE8, SXE8/A, SXQ4/A, SXU, SXU/A, VAG2, VAG2/A, VA2/A, VDE2, VDE2/A, VKB2, VKB2/A, VKE4, VKX4, VMA4, VME2, VME2/A, VME4, VMS2, VMT, VMX2, VM2, VM2/A, VNG1/A, VNT2, VNT2/A, VN17, VN17/A, VPE4, VPE4/A, VPE5, VPE7, VPE7/A, VPX4, VPX4/A, VPX5, VPX7, VPX7/A, VSD/A, VSD3/A, VSD7, VSD7/A, VSH7, VS37, VS37/A, VWA2/A, VWN2/A, VWT4, VWT4/A, VW12/A, VXB/A, VXB7, VXB7/A, VXEB/A, VXE4/A, VXE6, VXE6/A, VXE7, VXE7/A, VXP/A, VXQ4/A, VXTB, VXT1, VXU1, VXU1/A, WMA4, WMT8, WXE8	
					-	-	1	1000010	-----	VXP, VXQP
	A		90201-ZE3-790	1	1	-	2432846	-----	ESS/A, ES1/A, ES3/A, HX/A, LH/A, LHB5, LHE/A, LJ/A, LJG/A, LT/A, LW/A, LWD1/A, LX/A, LXE/A, L1/A, PX/A, QAB3/A, QD/A, QH/A, QHB5, QHP1/A, QHZ/A, QMH/A, QP/A, QSE/A, QT/A, QX/A, QXE/A, QXE9, QXK, Q1/A, RD/A, RSS/A, RX/A, R1/A, SD/A, SH/A, SJ/A, SJG/A, SN/A, SX/A, SXE/A, S1/A, VKK, VMT/A, VPK, VS3, VS4, VX/A, VXE8, VXX, VXT1/A, VXU/A, WMT8/A, WXE8/A, W1/A

NOTE A:PART NO. CHANGE D:NEWLY PROVIDED E:PART NO.DELETION K:REQUIRED NO. CORRECTION L:APPLICATION SERIAL NO. CORRECTION
T:APPLICATION CORRECTION Z:REMARKS CHANGE



PARTS CATALOGUE NEWS

Honda Motor Co., Ltd. Service Division

PARTS CATALOGUE - CORRECTED

Printed in Japan

CODE NO.	BOOKLET TYPE	13ZH90E9
	MICRO- FICHE	13ZH90EI/FI
PARTS CATALOGUE NEWS	GX270 GX270[PROPANE ENGINE]	
NEWS NO.	011	

Block No.	Ref. No.	Note	Part No.	Description	Reqd. QTY			Serial No.	Parts catalogue code	
					(1)	(2)	(3)			
E-16-4	7	L	18333-ZE3-800	GASKET, EX. PIPE	1	-	-	-----	ES3, VKE4, VKX4, VMT	
					1	-	-	-----	2425148	ES3/A, VMT/A, VS3, VS4
					1	-	-	-----	2435064	VKK
	15	T	18333-ZF6-W01	GASKET, EX. PIPE	1	-	-	2425149	-----	ES3/A, VMT/A, VS3, VS4
					1	-	-	2435065	-----	VKK

NOTE A:PART NO. CHANGE D:NEWLY PROVIDED E:PART NO.DELETION K:REQUIRED NO. CORRECTION L:APPLICATION SERIAL NO. CORRECTION
T:APPLICATION CORRECTION Z:REMARKS CHANGE



PARTS CATALOGUE NEWS

Honda Motor Co., Ltd. Service Division

PARTS CATALOGUE - CORRECTED

Printed in Japan

CODE NO.	BOOKLET TYPE	13ZH90E9
	MICRO-FICHE	13ZH90EI/FI
PARTS CATALOGUE NEWS	GX270 GX270[PROPANE ENGINE]	
NEWS NO.	012	

Block No.	Ref. No.	Note	Part No.	Description	Reqd. QTY GX270 (1) (2) (3)	Serial No.	Parts catalogue code
-----------	----------	------	----------	-------------	-----------------------------------	------------	----------------------

E-14 CARBURETOR (1)

ILLUSTRATION CORRECTED

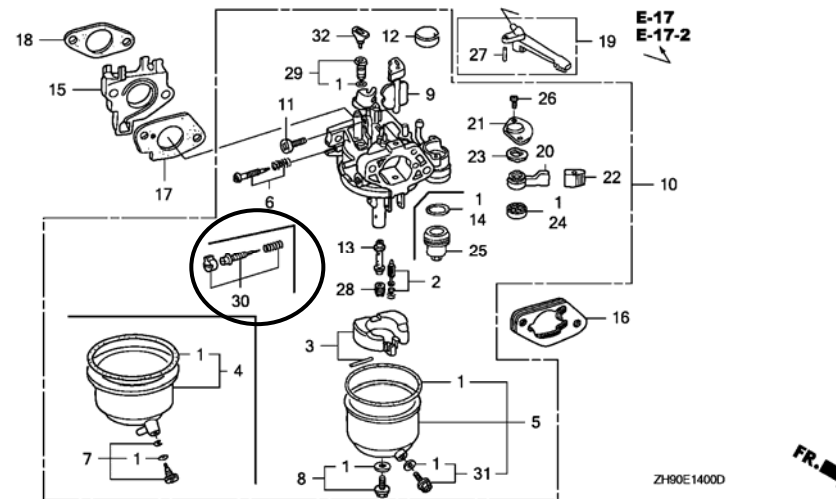

NOTE A:PART NO. CHANGE D:NEWLY PROVIDED E:PART NO.DELETION K:REQUIRED NO. CORRECTION L:APPLICATION SERIAL NO. CORRECTION
T:APPLICATION CORRECTION Z:REMARKS CHANGE

PARTS CATALOGUE NEWS

BOOKNo. : 13ZH90E9

Block No.	Ref. No.	Note	Part No.	Description	Reqd. QTY			Serial No.	Parts catalogue code
					(1)	(2)	(3)		
E-14	1	Z	16010-ZE2-015	GASKET SET (EXCEPT 16173-001-004)	1	(1)	-	-----	ES1, HA, HEA, HH, LHB1, LHB3, LHQ4, LJ, LJC, LJG, LSS, LT, LTJ, LW LWD1, LXZ, L1, PA, QA, QAB1, QAE, QD, QD/A, QE, QHC, QHE, QKE3, QP QSC, QT, QXC, QXC4, QXC4/A, QXEB, Q1, Q2, RA, RD, RD/A, RHE, R1 SD, SD/A, SE, SHE, SHEZ, SJ, SJG, SJP, SK, SKE1, SMC4, SMC4/A SME6, SN, SN/A, SW, SWE, S1, VA, VAW, VAW1, VWA, VWT4, VXT1, V1, W1
				(CARBURETOR NO.)	1	-	-	-----	BE21A B LX16, VD16, VEB6
				(CARBURETOR NO.)	1	-	-	-----	BE21A C ES1/A, HX, HXQ4, HX8, LH, LHE, LJ/A, LJC/A, LJG/A, LT/A, LW/A LWD1/A, LX, LXE, LXE8, LXQ4, LXU, PX, PXU, QAB3, QAQ4, QE/A, QH QHE4, QHP1, QHQ4, QHZ, QKE3/A, QME2, QMH, QP/A, QSE, QSE8, QT/A QX, QXB, QXE, QXE4, QXE8, QXQ4, QXU, RH, RHE4, RHQ4, RX, RXQ4 RXU, SE/A, SH, SHQ4, SJ/A, SJG/A, SMD, SME1, SME6/A, SWC4, SX SXB, SXE, SXEB, SXE4, SXE8, SXQ4, SXU, VDE, VH, VNG1, VSD VWT4/A, VX, VXB, VXE, VXEB, VXE4, VXG, VXQ4, VXTB, VXT1/A, VXU VXU1
				(CARBURETOR NO.)	1	-	-	-----	BE21B B WMT8
				(CARBURETOR NO.)	-	(1)	-	BE21B B -----	L1/A, Q1/A, R1/A, S1/A, W1/A
		Z	16010-ZE2-015	GASKET SET (EXCEPT 16173-001-004)	-	(1)	-	-----	BE21A C L1/A, Q1/A, R1/A, S1/A, W1/A
		Z	16010-ZE2-015	GASKET SET (EXCEPT 16173-001-004)	-	(1)	-	-----	BE24B C L1/A, Q1/A, R1/A, S1/A, W1/A
		Z	16010-ZE2-812	GASKET SET (INCLUDE 16173-001-004)	1	-	-	-----	QXE9, QXK, VXE8, VVK, WMA4
				(CARBURETOR NO.)	-	(1)	-	BE21A D -----	L1/A, Q1/A, R1/A, S1/A, W1/A

PARTS NAME CORRECTED

NOTE A:PART NO. CHANGE D:NEWLY PROVIDED E:PART NO.DELETION K:REQUIRED NO. CORRECTION L:APPLICATION SERIAL NO. CORRECTION T:APPLICATION CORRECTION Z:REMARKS CHANGE

PARTS CATALOGUE NEWS

BOOKNo. : 13ZH90E9

Block No.	Ref. No.	Note	Part No.	Description	Reqd. QTY			Serial No.	Parts catalogue code
					(1)	(2)	(3)		
					1	-	-	-----	HAQ, HA2, HA2/A, HEA2, HEA2/A, HEA8, HEA8/A, HX/A, HXQ4/A, HX26, HX26/A, HX8/A, LH/A, LHB5, LHE/A, LX/A, LXE/A, LXE8/A, LXQ4/A, LXU/A, PAE2, PAE2/A, PA2, PA2/A, PX/A, PXE8, PXE8/A, PXU/A, PX26, PX26/A, QAB3/A, QAE2, QAE2/A, QAE6, QAE6/A, QAG, QAG/A, QAG2, QAG2/A, QAG, QAG4/A, QAR2, QAR2/A, QAW, QAW/A, QA2, QA2/A, QH/A, QHB5, QHE4/A, QHP1/A, QHQ4/A, QHR, QHR/A, QHR4, QHR4/A, QHZ/A, QH26, QH26/A, QKE4, QL2, QME2/A, QMH/A, QSC9, QSC9/A, QSE/A, QSE2, QSE8/A, QWA2, QWA4, QWA4/A, QWH2, QWH2/A, QX/A, QXB/A, QXB6, QXB6/A, QXB7, QXB7/A, QXC6, QXC6/A, QXC9, QXC9/A, QXE/A, QXE4/A, QXE6, QXE6/A, QXE8/A, QXE9, QXK, QXQ4/A, QXU/A, QX26, QX26/A, RA2, RA2/A, RHE4/A, RHQ4/A, RH26, RH26/A, RSC2, RSC2/A, RSS, RSS/A, RX/A, RXQ4/A, RXU/A, SH/A, SHQ4/A, SME1/A, SMX2, SWA4, SWC4/A, SX/A, SXB/A, SXB7, SXTB/A, SXE/A, SXEB/A, SXE4/A, SXE8/A, SXQ4/A, SXU/A, SX2, VAG2, VAG2/A, VA2, VA2/A, VDE2, VDE2/A, VKB2, VKB2/A, VMA4, VME2, VME2/A, VME4, VM2, VM2/A, VNG1/A, VNT2, VNT2/A, VN17, VN17/A, VSD/A, VSD7, VSD7/A, VSH7, VWA2, VWA2/A, VWN2, VWN2/A, VW12, VW12/A, VW22, VX/A, VXB/A, VXB2, VXB6, VXB7, VXB7/A, VXEB/A, VXE4/A, VXE6, VXE6/A, VXE7, VXE7/A, VXE8, VXX, VXQ4/A, VXU/A, VXU1/A, VX26, WMA4, WMT8/A, WXE8, WXE8/A
				(CARBURETOR NO.)	1	-	-	-----	BE17B A LWD
				(CARBURETOR NO.)	1	-	-	BE21A D	----- ES1/A, LJ/A, LJC/A, LJG/A, LT/A, LW/A, LWD1/A, QE/A, QKE3/A, QP/A, QT/A, SE/A, SJ/A, SJG/A, SME6/A, VWT4/A, VXT1/A
				(CARBURETOR NO.)	1	-	-	BE75B B	----- HX, HXQ4, HX8, LH, LHE, LX, LXE, LXE8, LXQ4, LXU, LX16, PX, PXU, QAB3, QAQ4, QH, QHE4, QHP1, QHQ4, QHZ, QME2, QMH, QSE, QSE8, QX, QXB, QXE, QXE4, QXE8, QXQ4, QXU, RH, RHE4, RHQ4, RX, RXQ4, RXU, SH, SHQ4, SMD, SME1, SWC4, SX, SXB, SXE, SXEB, SXE4, SXE8, SXQ4, SXU, VDE, VD16, VEB6, VH, VNG1, VSD, VX, VXB, VXE, VXEB, VXE4, VXG, VXQ4, VXTB, VXU, VXU1
				(CARBURETOR NO.)	1	-	-	BE76C A	----- WMT8
				(CARBURETOR NO.)	-	(1)	-	BE24B D	----- L1/A, Q1/A, R1/A, S1/A, W1/A
	Z		16010-ZE2-A20	GASKET SET (INCLUDE 16173-001-004)	1	-	-	BE17B B	----- LWD

NOTE A:PART NO. CHANGE D:NEWLY PROVIDED E:PART NO.DELETION K:REQUIRED NO. CORRECTION L:APPLICATION SERIAL NO. CORRECTION
T:APPLICATION CORRECTION Z:REMARKS CHANGE

BOOKNo. : 13ZH90E9

Block No.	Ref. No.	Note	Part No.	Description	Reqd. QTY	Serial No.	Parts catalogue code
					GX270 (1) (2) (3)		

E-14-1 CARBURETOR (2)

ILLUSTRATION CORRECTED

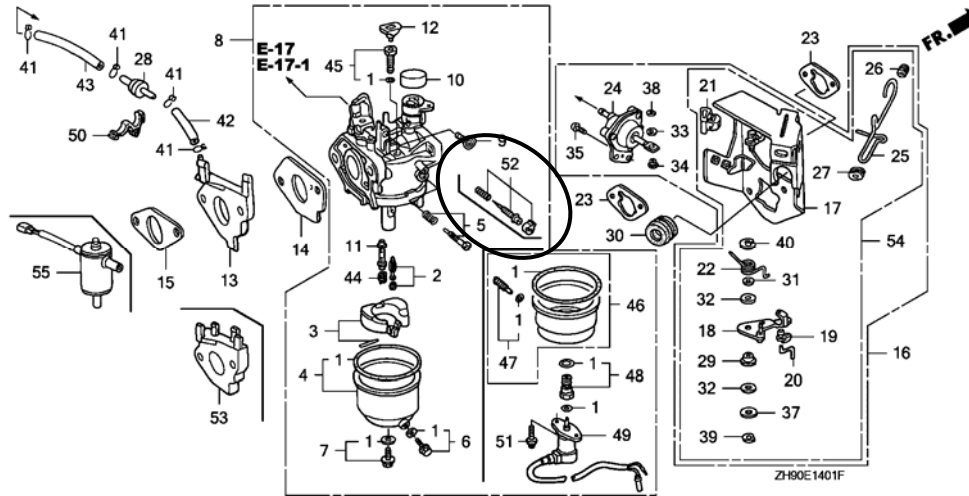

NOTE A:PART NO. CHANGE D:NEWLY PROVIDED E:PART NO.DELETION K:REQUIRED NO. CORRECTION L:APPLICATION SERIAL NO. CORRECTION
T:APPLICATION CORRECTION Z:REMARKS CHANGE

BOOKNo. : 13ZH90E9

Block No.	Ref. No.	Note	Part No.	Description	Reqd. QTY			Serial No.	Parts catalogue code
					(1)	(2)	(3)		

E-14-2 CARBURETOR (3)

ILLUSTRATION CORRECTED

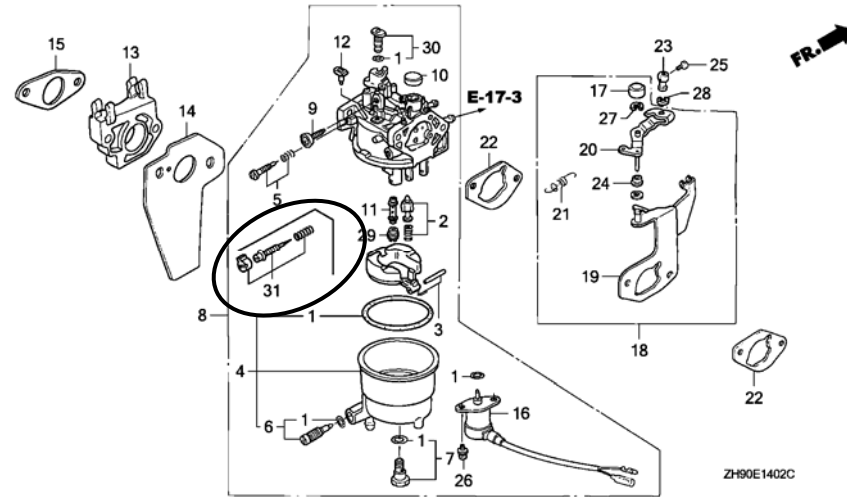

NOTE A:PART NO. CHANGE D:NEWLY PROVIDED E:PART NO.DELETION K:REQUIRED NO. CORRECTION L:APPLICATION SERIAL NO. CORRECTION
T:APPLICATION CORRECTION Z:REMARKS CHANGE



PARTS CATALOGUE NEWS

Honda Motor Co., Ltd. Service Division

PARTS CATALOGUE - CORRECTED

Printed in Japan

CODE NO.	BOOKLET TYPE	13ZH90E9
	MICRO-FICHE	13ZH90EI/FI
PARTS CATALOGUE NEWS	GX270 GX270[PROPANE ENGINE]	
NEWS NO.	013	

Block No.	Ref. No.	Note	Part No.	Description	Reqd. QTY			Serial No.	Parts catalogue code	
					(1)	(2)	(3)			
E-17	5		17510-ZE2-800ZA	TANK COMP., FUEL	1	-	-	-----	2437508	QXK, VXE8
				NH1.....BLACK				2400588	-----	HA2/A, PA2/A, PXU/A, QAE2/A, QAA4/A, GAR2/A, QA2/A, QWA4/A, QWH2/A, QXB/A, QXC9/A, RA2/A, SMX2, SWC4/A, VA2/A, VMA4, VME2/A, VME4, VM2/A, VXE4/A, VXE7/A
			17510-ZE2-800ZC		1	-	-	2400588	2437508	PX/A, VXU/A
				NH31.....MCKINLEY WHITE				2400588	2437508	ES1/A, HX/A, LH/A, LHB5, LHE/A, LJ/A, LT/A, LW/A, LX/A, LXE/A, L1/A, PX/A, QAB3/A, QD/A, QH/A, QHB5, QHP1/A, QHZ/A, QMH/A, QP/A, QSE/A, QT/A, QX/A, QXE/A, Q1/A, RD/A, RX/A, R1/A, SD/A, SH/A, SJ/A, SN/A, SX/A, SXE/A, S1/A, VX/A, VXU/A, WMT8/A, WXE8/A, W1/A
		1	-	-	-----	2437508	QXE9, QXK, VXE8, VXK			

NOTE A:PART NO. CHANGE D:NEWLY PROVIDED E:PART NO.DELETION K:REQUIRED NO. CORRECTION L:APPLICATION SERIAL NO. CORRECTION
T:APPLICATION CORRECTION Z:REMARKS CHANGE

PARTS CATALOGUE NEWS

BOOKNo. : 13ZH90E9

Block No.	Ref. No.	Note	Part No.	Description	Reqd. QTY			Serial No.	Parts catalogue code
					(1)	(2)	(3)		
					1	-	-	2400588	----- HA2/A, HEA2/A, HEA8/A, HXQ4/A, HX26/A, HX8/A, LJC/A, LXE8/A, LXQ4/A, LXU/A, PAE2/A, PA2/A, PXE8/A, PXU/A, PX26/A, QAE2/A, QAE6/A, QAG/A, QAG2/A, QAQ4/A, QAR2/A, QAW/A, QA2/A, QE/A, QHE4/A, QHQ4/A, QHR/A, QHR4/A, QH26/A, QME2/A, QSE2, QSE8/A, QWA4/A, QXB/A, QXB6/A, QXB7/A, QXC4/A, QXC6/A, QXC9/A, QXE4/A, QXE6/A, QXE8/A, QXQ4/A, QXU/A, QX26/A, RA2/A, RHE4/A, RHQ4/A, RH26/A, RXQ4/A, RXU/A, SE/A, SHQ4/A, SMC4/A, SME1/A, SME6/A, SWA4, SWC4/A, SXB/A, SXB7/A, SXEB/A, SXE4/A, SXE8/A, SXQ4/A, SXU/A, VA2/A, VME2/A, VM2/A, VSD/A, VSD7/A, VXB/A, VXB7/A, VXEB/A, VXE4/A, VXE6/A, VXE7/A, VXQ4/A, VXU1/A, WMA4
			17510-ZE2-800ZD	*R280*..... POWER RED	1	-	-	2400588	2437508 ES1/A
	A		17510-ZE2-801ZA	*NH1*..... BLACK	1	-	-	2437509	----- PX/A, QXK, VXE8, VXU/A
	A		17510-ZE2-801ZC	*NH31*..... MCKINLEY WHITE	1	(1)	-	2437509	----- ES1/A, HX/A, LH/A, LHB5, LHE/A, LJ/A, LT/A, LW/A, LX/A, LXE/A, L1/A, PX/A, QAB3/A, QD/A, QH/A, QHB5, QHP1/A, QHZ/A, QMH/A, QP/A, QSE/A, QT/A, QX/A, QXE/A, QXE9, QXK, Q1/A, RD/A, RX/A, R1/A, SD/A, SH/A, SJ/A, SN/A, SX/A, SXE/A, S1/A, VX/A, VXE8, VXU/A, WMT8/A, WXE8/A, W1/A
	A		17510-ZE2-801ZD	*R280*..... POWER RED	1	-	-	2437509	----- ES1/A

NOTE A:PART NO. CHANGE D:NEWLY PROVIDED E:PART NO.DELETION K:REQUIRED NO. CORRECTION L:APPLICATION SERIAL NO. CORRECTION
T:APPLICATION CORRECTION Z:REMARKS CHANGE

April 22, 2007



PARTS CATALOGUE NEWS

Honda Motor Co., Ltd. Service Division

PARTS CATALOGUE - CORRECTED

Printed in Japan

CODE NO.	BOOKLET TYPE	13ZH90E9
	MICRO- FICHE	13ZH90E1/FI
PARTS CATALOGUE NEWS	GX270 GX270[PROPANE ENGINE]	
NEWS NO.	014	

NOTE A:PART NO. CHANGE D:NEWLY PROVIDED E:PART NO.DELETION K:REQUIRED NO. CORRECTION L:APPLICATION SERIAL NO. CORRECTION
T:APPLICATION CORRECTION Z:REMARKS CHANGE

PARTS CATALOGUE NEWS

BOOKNo. : 13ZH90E9

Block No.	Ref. No.	Note	Part No.	Description	Reqd. QTY			Serial No.	Parts catalogue code
					(1)	(2)	(3)		
E-2	16		95725-10080-00	BOLT, FLANGE, 10X80	4	4	-	-----	ESS, ES1, ES3, HA, HAQ, HA2, HA2/A, HEA, HEA2, HEA2/A, HEA8 HEA8/A, HH, HX, HXQ4, HXQ4/A, HX26, HX26/A, HX8, HX8/A, LH LHB1, LHB3, LHE, LHQ4, LJ, LJC, LJC/A, LJJ, LSS, LT, LTJ, LW, LWD LWD1, LX, LXE, LXE8, LXE8/A, LXQ4, LXQ4/A, LXU, LXU/A, LXZ LX16, L1, PA, PAE2, PAE2/A, PA2, PA2/A, PX, PXE8, PXE8/A, PXU PXU/A, PX26, PX26/A, QA, QAB1, QAB3, QAE, QAE2, QAE2/A, QAE6 QAE6/A, QAG, QAG/A, QAG2, QAG2/A, QAQ, QAQ4, QAQ4/A, QAR2 QAR2/A, QAW, QAW/A, QA2, QA2/A, QD, QE, QE/A, QH, QHC, QHE, QHE4 QHE4/A, QHP1, QHQ4, QHQ4/A, QHR, QHR/A, QHR4, QHR4/A, QHZ QH26, QH26/A, QKE3, QKE3/A, QKE4, QL2, QME2, QME2/A, QMH, QP QSC, QSC9, QSC9/A, QSE, QSE2, QSE8, QSE8/A, QT, QWA2, QWA4 QWA4/A, QWH2, QWH2/A, QX, QXB, QXB/A, QXB6, QXB6/A, QXB7 QXB7/A, QXC, QXC4, QXC4/A, QXC6, QXC6/A, QXC9, QXC9/A, QXE QXEB, QXE4, QXE4/A, QXE6, QXE6/A, QXE8, QXE8/A, QXQ4, QXQ4/A QXU, QXU/A, QX26, QX26/A, Q1, Q2, RA, RA2, RA2/A, RD, RH, RHE RHE4, RHE4/A, RHQ4, RHQ4/A, RH26, RH26/A, RSC2, RSC2/A, RSS RX, RXQ4, RXQ4/A, RXU, RXU/A, R1, SD, SE, SE/A, SH, SHE, SHE2 SHQ4, SHQ4/A, SJ, SJG, SJP, SK, SKE1, SMC4, SMC4/A, SMD, SME1 SME1/A, SME6, SME6/A, SMX2, SN, SW, SWA4, SWC4, SWC4/A, SWE, SX SXB, SXB/A, SXB7, SXB7/A, SXE, SXEB, SXEB/A, SXE4, SXE4/A SXE8, SXE8/A, SXQ4, SXQ4/A, SXU, SXU/A, SX2, S1, VA, VAG2 VAG2/A, VAW, VAW1, VA2, VA2/A, VDE, VDE2, VDE2/A, VD16, VEB6 VH, VKB2, VKB2/A, VKE4, VKX4, VMA4, VME2, VME2/A, VME4, VMS2 VMT, VMX2, VM2, VM2/A, VNG1, VNG1/A, VNT2, VNT2/A, VN17 VN17/A, VPE4, VPE4/A, VPE5, VPE7, VPE7/A, VPX4, VPX4/A, VPX5 VPX7, VPX7/A, VSD, VSD/A, VSD3, VSD3/A, VSD7, VSD7/A, VSH7 VS37, VS37/A, VWA, VWA2, VWA2/A, VWN2, VWN2/A, VWT4, VWT4/A VW12, VW12/A, VW22, VX, VXB, VXB/A, VXB2, VXB6, VXB7, VXB7/A VXE, VXEB, VXEB/A, VXE4, VXE4/A, VXE6, VXE6/A, VXE7, VXE7/A VXG, VXQ4, VXQ4/A, VXTB, VXT1, VXU, VXU1, VXU1/A, VX26, V1 WMA4, WMT8, WXE8, W1
					4	4	-	----- 2438763	ESS/A, ES1/A, ES3/A, HX/A, LH/A, LHB5, LHE/A, LJ/A, LJJ/A LT/A, LW/A, LWD1/A, LX/A, LXE/A, L1/A, PX/A, QAB3/A, QD/A QH/A, QHB5, QHP1/A, QHZ/A, QMH/A, QP/A, QSE/A, QT/A, QX/A QXE/A, QXE9, QXK, Q1/A, RD/A, RSS/A, RX/A, R1/A, SD/A, SH/A SJ/A, SJG/A, SN/A, SX/A, SXE/A, S1/A, VKK, VMT/A, VPK, VS3, VS4 VX/A, VXE8, VXX, VXT1/A, VXU/A, WMT8/A, WXE8/A, W1/A
					-	-	4		
	A		95701-10080-00	4	4	-	2438764 -----	ESS/A, ES1/A, ES3/A, HX/A, LH/A, LHB5, LHE/A, LJ/A, LJJ/A LT/A, LW/A, LWD1/A, LX/A, LXE/A, L1/A, PX/A, QAB3/A, QD/A QH/A, QHB5, QHP1/A, QHZ/A, QMH/A, QP/A, QSE/A, QT/A, QX/A QXE/A, QXE9, QXK, Q1/A, RD/A, RSS/A, RX/A, R1/A, SD/A, SH/A SJ/A, SJG/A, SN/A, SX/A, SXE/A, S1/A, VKK, VMT/A, VPK, VS3, VS4 VX/A, VXE8, VXX, VXT1/A, VXU/A, WMT8/A, WXE8/A, W1/A

NOTE A:PART NO. CHANGE D:NEWLY PROVIDED E:PART NO.DELETION K:REQUIRED NO. CORRECTION L:APPLICATION SERIAL NO. CORRECTION
T:APPLICATION CORRECTION Z:REMARKS CHANGE

PARTS CATALOGUE NEWS

BOOKNo. : 13ZH90E9

Block No.	Ref. No.	Note	Part No.	Description	Reqd. QTY			Serial No.	Parts catalogue code
					(1)	(2)	(3)		
PARTS NAME CORRECTED									
E-14	10	Z	16100-ZH9-W01	CARBURETOR ASSY. (BE75A B/C)	1	-	-	-----	QSC9/A, QWA2, QWA4, QWA4/A, QWH2, QWH2/A, QXC6/A, QXC9/A, QXK VMA4, VME4
					1	-	-	1175951	HAQ, QAO, QSC9, QXC6, QXC9
		Z	16100-ZH9-822	CARBURETOR ASSY. (BE21A D/E)	1	-	-	2295157	ES1/A, LJ/A, LJC/A, LJG/A, LT/A, LW/A, LWD1/A, QE/A, QKE3/A QP/A, QT/A, SE/A, SJ/A, SJG/A, SME6/A, VWT4/A, VXT1/A
				(COCK&STRAINER)	-	(1)	-	2295157	L1/A, Q1/A, R1/A, S1/A, W1/A
	29	L	99204-ZE0-0350	JET SET, PILOT, #35 (CARBURETOR NO.)	1	-	-	-----	BE75A B HAQ, QAO, QSC9, QSC9/A, QWA2, QWA4, QWA4/A, QWH2, QWH2/A, QXC6 QXC6/A, QXC9, QXC9/A, QXK, VMA4, VME4
		D	99204-ZE2-0400	JET SET, PILOT, #40 (CARBURETOR NO.)	1	-	-	BE75A C	----- HAQ, QAO, QSC9, QSC9/A, QWA2, QWA4, QWA4/A, QWH2, QWH2/A, QXC6 QXC6/A, QXC9, QXC9/A, QXK, VMA4, VME4

PARTS NAME CORRECTED									
E-14-1	8	Z	16100-Z5H-V02	CARBURETOR ASSY. (BE21F B/C)	1	-	-	-----	VPK
		Z	16100-Z5J-V12	CARBURETOR ASSY. (BE21G B/C)	1	-	-	-----	VKK
E-23-2	5		31620-ZG5-013	RECTIFIER ASSY., REGULATOR (20A)	-	(1)	-	-----	2437499 L1/A, Q1/A, R1/A, S1/A, W1/A
		A	31620-ZG5-023	-	(1)	-	2437500	----- L1/A, Q1/A, R1/A, S1/A, W1/A
E-28	3		87521-ZH9-030	EMBLEM (GX270 9.0)	1	-	-	-----	SMX2, SWA4, VKE4, VKX4, VMA4, VME4, VMS2, VMX2, VPE5, VPX5 VSH7, WMA4
					1	-	-	2437806	----- QXE9, QXK, VKK, VPK, VS3, VXE8, VXK

NOTE A:PART NO. CHANGE D:NEWLY PROVIDED E:PART NO.DELETION K:REQUIRED NO. CORRECTION L:APPLICATION SERIAL NO. CORRECTION T:APPLICATION CORRECTION Z:REMARKS CHANGE

PARTS CATALOGUE NEWS

BOOKNo. : 13ZH90E9

Block No.	Ref. No.	Note	Part No.	Description	Reqd. QTY			Serial No.	Parts catalogue code
					(1)	(2)	(3)		
					1	-	-	2082941 -----	HA2/A, HEA2/A, HEA8/A, HXQ4/A, HX26/A, HX8/A, LXE8/A, LXQ4/A, LXU/A, PAE2/A, PA2/A, PXE8/A, PXU/A, PX26/A, QAE2/A, QAE6/A, QAG/A, QAG2/A, QAQ4/A, QAR2/A, QAW/A, QA2/A, QE/A, QHE4/A, QHQ4/A, QHR/A, QHR4/A, QH26/A, QME2/A, QSC9/A, QSE2, QSE8/A, QWA4/A, QWH2/A, QXB/A, QXB6/A, QXB7/A, QXC4/A, QXC6/A, QXC9/A, QXE4/A, QXE6/A, QXE8/A, QXQ4/A, QXU/A, QX26/A, RA2/A, RHE4/A, RHQ4/A, RH26/A, RSC2/A, RXQ4/A, RXU/A, SE/A, SHQ4/A, SMC4/A, SME1/A, SME6/A, SWG4/A, SXB/A, SXB7/A, SXEB/A, SXE4/A, SXE8/A, SXQ4/A, SXU/A, VAG2/A, VA2/A, VDE2/A, VKB2/A, VME2/A, VM2/A, VNG1/A, VNT2/A, VN17/A, VPE4/A, VPE7/A, VPX4/A, VPX7/A, VSD/A, VSD3/A, VSD7/A, VS37/A, VWA2/A, VWN2/A, VWT4/A, VW12/A, VXB/A, VXB7/A, VXEB/A, VXE4/A, VXE6/A, VXE7/A, VXQ4/A, VXU1/A
					1	-	-	2082941 2437806	ES1/A, ES3/A, HX/A, LH/A, LHB5, LHE/A, LT/A, LW/A, LX/A, LXE/A, PX/A, QAB3/A, QD/A, QH/A, QHB5, QHP1/A, QHZ/A, QMH/A, QP/A, QSE/A, QT/A, QX/A, QXE/A, RD/A, RX/A, SD/A, SH/A, SN/A, SX/A, SXE/A, VMT/A, VX/A, VXT1/A, VXU/A, WMT8/A, WXE8/A
					-	-	1	1100009 -----	HAP/A, RXP/A, VXP/A
	A		87521-ZH9-040	EMBLEM (GX270)	1	-	-	2437807 -----	ES1/A, ES3/A, HX/A, LH/A, LHB5, LHE/A, LT/A, LW/A, LX/A, LXE/A, PX/A, QAB3/A, QD/A, QH/A, QHB5, QHP1/A, QHZ/A, QMH/A, QP/A, QSE/A, QT/A, QX/A, QXE/A, QXE9, QXK, RD/A, RX/A, SD/A, SH/A, SN/A, SX/A, SXE/A, VKK, VMT/A, VPK, VS3, VX/A, VXE8, VXX, VXT1/A, VXU/A, WMT8/A, WXE8/A

NOTE A:PART NO. CHANGE D:NEWLY PROVIDED E:PART NO.DELETION K:REQUIRED NO. CORRECTION L:APPLICATION SERIAL NO. CORRECTION
T:APPLICATION CORRECTION Z:REMARKS CHANGE

BOOKNo. : 13ZH90E9

Block No.	Ref. No.	Note	Part No.	Description	Reqd. QTY			Serial No.	Parts catalogue code
					(1)	(2)	(3)		

E-40-10 OTHER PARTS

(EMERGENCY STOP SWITCH)

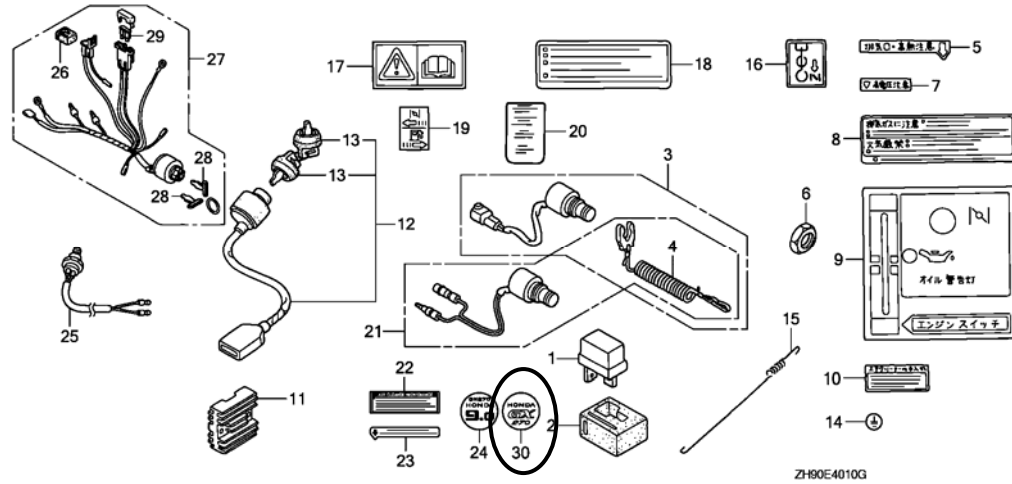

ZH90E4010G

E-40-10	24	L	87521-ZH9-030	EMBLEM (GX270 9.0)	1	-	-	-----	2437806	VKK, VS4
	30	D	87521-ZH9-040	EMBLEM (GX270)	1	-	-	-----	2437807	VKK, VS4

NOTE A:PART NO. CHANGE D:NEWLY PROVIDED E:PART NO.DELETION K:REQUIRED NO. CORRECTION L:APPLICATION SERIAL NO. CORRECTION
T:APPLICATION CORRECTION Z:REMARKS CHANGE



PARTS CATALOGUE NEWS

Honda Motor Co., Ltd. Service Division

PARTS CATALOGUE - CORRECTED

Printed in Japan

CODE NO.	BOOKLET TYPE	13ZH90E9
	MICRO-FICHE	13ZH90EI/FI
PARTS CATALOGUE NEWS	GX270 GX270[PROPANE ENGINE]	
NEWS NO.	015	

Block No.	Ref. No.	Note	Part No.	Description	Reqd. QTY			Serial No.	Parts catalogue code	
					(1)	(2)	(3)			
E-3	16		34150-ZH7-003	ALERT UNIT, OIL	1	(1)	-	----- 2440203	ESS/A, ES1/A, ES3/A, HX/A, LX/A, PX/A, QX/A, QXK, Q1/A, RX/A, SX/A, S1/A, VKK, VMT/A, VPK, VS3, VS4, VX/A, VXX, VXU/A	
					1	(1)	-	1321603	-----	ESS, ES1, ES3, HA2, HX, HXQ4, HX26, LX, LXQ4, LX16, PA2, PX, PX26, QAB3, QAQ4, QAR2, QA2, QKE3, QME2, QX, QXB, QXC4, QXC6, QXC9, QXQ4, QX26, Q1, RA2, RSC2, RX, RXQ4, SMC4, SMD, SME1, SME6, SWC4, SX, SXB, SXQ4, S1, VA2, VD16, VM2, VNG1, VNT2, VPE4, VPX4, VSD, VSD3, VWA2, VWN2, VWT4, VW12, VW22, VX, VXB, VXB2, VXG, VXQ4, VXTB, VXU, VX26
					1	-	1	-----	-----	HAP, HAP/A, HA2/A, HXQ4/A, HX26/A, HX8, HX8/A, LJC, LJC/A, LXQ4/A, LXU, LXU/A, PA2/A, PXU, PXU/A, PX26/A, QAB3/A, QAG, QAG/A, QAG2, QAG2/A, QAQ4/A, QAR2/A, QAW, QAW/A, QA2/A, QKE3/A, QL2, QME2/A, QWA2, QWA4, QWA4/A, QWH2, QWH2/A, QXB/A, QXB7, QXB7/A, QXC4/A, QXC6/A, QXC9/A, QXQ4/A, QXU, QXU/A, QX26/A, RA2/A, RSC2/A, RXP, RXP/A, RXQ4/A, RXU, RXU/A, SMC4/A, SME1/A, SME6/A, SMX2, SWA4, SWC4/A, SXB/A, SXB7, SXB7/A, SXQ4/A, SXU, SXU/A, VAG2, VAG2/A, VA2/A, VKE4, VKX4, VMA4, VME4, VMT, VMX2, VM2/A, VNG1/A, VNT2/A, VN17, VN17/A, VPE4/A, VPE5, VPE7, VPE7/A, VPX4/A, VPX5, VPX7, VPX7/A, VSD/A, VSD3/A, VSD7, VSD7/A, VSH7, VS37, VS37/A, VWA2/A, VWN2/A, VWT4/A, VW12/A, VXB/A, VXB7, VXB7/A, VXP/A, VXQ4/A, VXT1, VXT1/A, VXU1, VXU1/A, WMT8, WMT8/A
					-	-	1	1000070	-----	VXP, VXQP

NOTE A:PART NO. CHANGE D:NEWLY PROVIDED E:PART NO.DELETION K:REQUIRED NO. CORRECTION L:APPLICATION SERIAL NO. CORRECTION
T:APPLICATION CORRECTION Z:REMARKS CHANGE

PARTS CATALOGUE NEWS

BOOKNo. : 13ZH90E9

Block No.	Ref. No.	Note	Part No.	Description	Reqd. QTY			Serial No.	Parts catalogue code
					(1)	(2)	(3)		
		A	34150-ZH7-013	1	GX270 (1)	(1) -	2440204 -----	ESS/A, ES1/A, ES3/A, HX/A, LX/A, PX/A, QX/A, QXK, Q1/A, RX/A, SX/A, S1/A, VKK, VMT/A, VPK, VS3, VS4, VX/A, VXX, VXU/A
E-7	9		92000-08025-0A	BOLT, HEX., 8X25	1	(1)	-	-----	R1, SJP, SK, S1
					-	(1)	-	-----	2437805 R1/A, S1/A
		A	92101-08025-0A	-	(1)	-	2437806 -----	R1/A, S1/A
E-14-1	16		16260-ZE2-722	STAY ASSY., MANUAL CHOKE	1	-	-	-----	ES3, VKE4, VMT, VPE4, VPE7, VPE7/A, VPX4, VPX7, VPX7/A, VSD3, VSD3/A, VS37
					1	-	-	-----	2207390 VKX4, VPE4/A, VPE5, VPX4/A, VPX5, VS37/A
					1	-	-	-----	2440240 ES3/A, VKK, VMT/A, VS3, VS4
		A	16260-ZE2-723	1	-	-	2440241 -----	ES3/A, VKK, VMT/A, VS3, VS4
	24		16400-ZE2-703	DIAPHRAGM ASSY.	1	-	-	-----	ES3, VKE4, VKX4, VMT, VPE4, VPE4/A, VPE5, VPE7, VPE7/A, VPK, VPX4, VPX4/A, VPX5, VPX7, VPX7/A, VSD3, VSD3/A, VS37, VS37/A
					1	-	-	-----	2440240 ES3/A, VKK, VMT/A, VS3, VS4
		A	16400-ZE2-704	1	-	-	2440241 -----	ES3/A, VKK, VMT/A, VS3, VS4

NOTE A:PART NO. CHANGE D:NEWLY PROVIDED E:PART NO.DELETION K:REQUIRED NO. CORRECTION L:APPLICATION SERIAL NO. CORRECTION
T:APPLICATION CORRECTION Z:REMARKS CHANGE

PARTS CATALOGUE NEWS

BOOKNo. : 13ZH90E9

Block No.	Ref. No.	Note	Part No.	Description	Reqd. QTY			Serial No.	Parts catalogue code
					(1)	(2)	(3)		
E-20	1		30500-ZF6-W02	COIL ASSY., IGNITION	1	(1)	-	-----	ESS, ES1, ES3, HA, HAQ, HA2, HA2/A, HEA, HEA2, HEA2/A, HEA8 HEA8/A, HH, HX, HXQ4, HXQ4/A, HX26, HX26/A, HX8, HX8/A, LH LHB1, LHB3, LHE, LHQ4, LJ, LJC, LJC/A, LJJ, LSS, LT, LTJ, LW, LWD LWD1, LX, LXE, LXE8, LXE8/A, LXQ4, LXQ4/A, LXU, LXU/A, LXZ LX16, L1, PA, PAE2, PAE2/A, PA2, PA2/A, PX, PXE8, PXE8/A, PXU PXU/A, PX26, PX26/A, QA, QAB1, QAB3, QAE, QAE2, QAE2/A, QAE6 QAE6/A, QAG, QAG/A, QAG2, QAG2/A, QAQ, QAQ4, QAQ4/A, QAR2 QAR2/A, QAW, QAW/A, QA2, QA2/A, QD, QE, QE/A, QH, QHC, QHE, QHE4 QHE4/A, QHP1, QHQ4, QHQ4/A, QHR, QHR/A, QHR4, QHR4/A, QHZ QH26, QH26/A, QKE3, QKE3/A, QKE4, QL2, QME2, QME2/A, QMH, QP QSC, QSC9, QSC9/A, QSE, QSE2, QSE8, QSE8/A, QT, QWA2, QWA4 QWA4/A, QWH2, QWH2/A, QX, QXB, QXB/A, QXB6, QXB6/A, QXB7 QXB7/A, QXC, QXC4, QXC4/A, QXC6, QXC6/A, QXC9, QXC9/A, QXE QXEB, QXE4, QXE4/A, QXE6, QXE6/A, QXE8, QXE8/A, QXQ4, QXQ4/A QXU, QXU/A, QX26, QX26/A, Q1, Q2, RA, RA2, RA2/A, RD, RH, RHE RHE4, RHE4/A, RHQ4, RHQ4/A, RH26, RH26/A, RSC2, RSC2/A, RSS RX, RXQ4, RXQ4/A, RXU, RXU/A, R1, SD, SE, SE/A, SH, SHE, SHE4 SHQ4, SHQ4/A, SJ, SJG, SJP, SK, SKE1, SMC4, SMC4/A, SMD, SME1 SME1/A, SME6, SME6/A, SMX2, SN, SW, SWA4, SWC4, SWC4/A, SWE, SX SXB, SXB/A, SXB7, SXB7/A, SXE, SXEB, SXEB/A, SXE4, SXE4/A SXE8, SXE8/A, SXQ4, SXQ4/A, SXU, SXU/A, SX2, S1, VA, VAG2 VAG2/A, VAW, VAW1, VA2, VA2/A, VDE, VDE2, VDE2/A, VD16, VEB6 VH, VKB2, VKB2/A, VKE4, VKX4, VMA4, VME2, VME2/A, VME4, VMS2 VMT, VMX2, VM2, VM2/A, VNG1, VNG1/A, VNT2, VNT2/A, VN17 VN17/A, VPE4, VPE4/A, VPE5, VPE7, VPE7/A, VPX4, VPX4/A, VPX5 VPX7, VPX7/A, VSD, VSD/A, VSD3, VSD3/A, VSD7, VSD7/A, VSH7 VS37, VS37/A, VWA, VWA2, VWA2/A, VWN2, VWN2/A, VWT4, VWT4/A VW12, VW12/A, VW22, VX, VXB, VXB/A, VXB2, VXB6, VXB7, VXB7/A VXE, VXEB, VXEB/A, VXE4, VXE4/A, VXE6, VXE6/A, VXE7, VXE7/A VXG, VXQ4, VXQ4/A, VXTB, VXT1, VXU, VXU1, VXU1/A, VX26, V1 WMA4, WMT8, WXE8, W1
					1	(1)	-	----- 2437805	ESS/A, ES1/A, ES3/A, HX/A, LH/A, LHB5, LHE/A, LJ/A, LJJ/A LT/A, LW/A, LWD1/A, LX/A, LXE/A, L1/A, PX/A, QAB3/A, QD/A QH/A, QHB5, QHP1/A, QHZ/A, QMH/A, QP/A, QSE/A, QT/A, QX/A QXE/A, QXE9, QXK, Q1/A, RD/A, RSS/A, RX/A, R1/A, SD/A, SH/A SJ/A, SJG/A, SN/A, SX/A, SXE/A, S1/A, VKK, VMT/A, VPK, VS3, VS4 VX/A, VXE8, VXE8, VXT1/A, VXU/A, WMT8/A, WXE8/A, W1/A
					-	-	1		
	A		30500-ZF6-W03	1	(1)	-	2437806 -----	ESS/A, ES1/A, ES3/A, HX/A, LH/A, LHB5, LHE/A, LJ/A, LJJ/A LT/A, LW/A, LWD1/A, LX/A, LXE/A, L1/A, PX/A, QAB3/A, QD/A QH/A, QHB5, QHP1/A, QHZ/A, QMH/A, QP/A, QSE/A, QT/A, QX/A QXE/A, QXE9, QXK, Q1/A, RD/A, RSS/A, RX/A, R1/A, SD/A, SH/A SJ/A, SJG/A, SN/A, SX/A, SXE/A, S1/A, VKK, VMT/A, VPK, VS3, VS4 VX/A, VXE8, VXE8, VXT1/A, VXU/A, WMT8/A, WXE8/A, W1/A

NOTE A:PART NO. CHANGE D:NEWLY PROVIDED E:PART NO.DELETION K:REQUIRED NO. CORRECTION L:APPLICATION SERIAL NO. CORRECTION
T:APPLICATION CORRECTION Z:REMARKS CHANGE

PARTS CATALOGUE NEWS

BOOKNo. : 13ZH90E9

Block No.	Ref. No.	Note	Part No.	Description	Reqd. QTY			Serial No.	Parts catalogue code
					(1)	(2)	(3)		
		9	31630-ZE1-003	COIL ASSY., CHARGE (1A)	1	(1)	-	-----	LHE, LTJ, LWD, LXE, LXE8, LXE8/A, L1, PXE8, PXE8/A, QHE, QHE4, QHE4/A, QXE, QXEB, QXE4, QXE4/A, QXE6, QXE6/A, QXE8, QXE8/A, Q1, Q1/A, Q2, RHE, RHE4, RHE4/A, R1, SHE, SHEZ, SWE, SXE, SXEB, SXEB/A, SXE4, SXE4/A, SXE8, SXE8/A, S1, VEB6, VME4, VPE4, VPE4/A, VPE5, VPE7, VPE7/A, VXE, VXEB, VXEB/A, VXE4, VXE4/A, VXE6, VXE6/A, VXE7, VXE7/A, V1, WMA4, WXE8, W1, W1/A
					1	(1)	-	-----	2437805 LHE/A, LXE/A, L1/A, QXE/A, QXE9, R1/A, SXE/A, S1/A, VPK, VXE8, WXE8/A
			31630-ZE2-841	COIL ASSY., CHARGE (3A)	1	(1)	-	-----	HEA, HEA2, HEA2/A, HEA8, HEA8/A, L1, L1/A, PAE2, PAE2/A, QAE, QAE2, QAE2/A, QAE6, QAE6/A, Q1, Q1/A, Q2, R1, R1/A, VDE, VDE2, VDE2/A, VKB2, VKB2/A, VKE4, VME2, VME2/A, VMS2, V1, W1, W1/A
					1	-	-	-----	2437763 VKK
		A	31630-ZE1-013	COIL ASSY., CHARGE (1A)	1	(1)	-	2437806	----- LHE/A, LXE/A, L1/A, QXE/A, QXE9, R1/A, SXE/A, S1/A, VPK, VXE8, WXE8/A
		A	31630-ZE2-842	COIL ASSY., CHARGE (3A)	1	-	-	2437764	----- VKK
E-21	1		31200-ZH9-003	MOTOR ASSY., STARTER	1	(1)	-	-----	HEA, HEA2, HEA2/A, HEA8, HEA8/A, LHE, LTJ, LWD, LWD1, LXE, LXE/A, LXE8, LXE8/A, L1, PAE2, PAE2/A, PXE8, PXE8/A, QAE, QAE2, QAE2/A, QAE6, QAE6/A, QHE, QHE4, QHE4/A, QHR4, QHR4/A, QKE3, QKE3/A, QKE4, QME2, QME2/A, QSC, QSC9, QSC9/A, QSE, QSE/A, QSE2, QSE8, QSE8/A, QXB6, QXB6/A, QXE, QXEB, QXE4, QXE4/A, QXE6, QXE6/A, QXE8, QXE8/A, Q1, Q2, RHE, RHE4, RHE4/A, R1, SHE, SHEZ, SKE1, SME1, SME1/A, SWE, SXE, SXEB, SXEB/A, SXE4, SXE4/A, SXE8, SXE8/A, S1, VDE, VDE2, VDE2/A, VEB6, VKB2, VKB2/A, VKE4, VME2, VME2/A, VME4, VMS2, VPE4, VPE4/A, VPE5, VPE7, VPE7/A, VWT4, VWT4/A, VXE, VXEB, VXEB/A, VXE4, VXE4/A, VXE6, VXE6/A, VXE7, VXE7/A, V1, WMA4, WXE8, WXE8/A, W1
					1	(1)	-	-----	2440203 LHE/A, LWD1/A, L1/A, QXE/A, QXE9, Q1/A, R1/A, SXE/A, S1/A, VKK, VPK, VXE8, W1/A
		A	31200-ZH9-013	1	(1)	-	2440204	----- LHE/A, LWD1/A, L1/A, QXE/A, QXE9, Q1/A, R1/A, SXE/A, S1/A, VKK, VPK, VXE8, W1/A
E-23	8		35100-ZE2-023	SWITCH ASSY., COMBINATION	1	(1)	-	-----	LHE, LTJ, L1, QHE, Q1, Q2, RHE, R1, SHE, SHEZ, SKE1, SWE, S1, V1, W1
					1	(1)	-	-----	2440203 LHE/A, L1/A, Q1/A, R1/A, S1/A, W1/A
		A	35100-ZE2-033	1	(1)	-	2440204	----- LHE/A, L1/A, Q1/A, R1/A, S1/A, W1/A

NOTE A:PART NO. CHANGE D:NEWLY PROVIDED E:PART NO.DELETION K:REQUIRED NO. CORRECTION L:APPLICATION SERIAL NO. CORRECTION
T:APPLICATION CORRECTION Z:REMARKS CHANGE

PARTS CATALOGUE NEWS

BOOKNo. : 13ZH90E9

Block No.	Ref. No.	Note	Part No.	Description	Reqd. QTY			Serial No.	Parts catalogue code					
					(1)	(2)	(3)							
E-23-1	10		35100-ZE2-023	SWITCH ASSY., COMBINATION	1	(1)	-	-----	LXE, LXE/A, LXE8, LXE8/A, L1, PXE8, PXE8/A, QHE4, QHE4/A, QXE QXEB, QXE4, QXE4/A, QXE6, QXE6/A, QXE8, QXE8/A, Q1, Q2, RHE4 RHE4/A, R1, SXE, SXEB, SXEB/A, SXE4, SXE4/A, SXE8, SXE8/A, S1 VEB6, VXE, VXE8, VXE8/A, VXE4, VXE4/A, VXE6, VXE6/A, VXE7 VXE7/A, V1, WMA4, WXE8, WXE8/A, W1					
					1	(1)	-	-----	2440203	L1/A, QXE/A, QXE9, Q1/A, R1/A, SXE/A, S1/A, VXE8, W1/A				
					1	(1)	-	-----	2440204	L1/A, QXE/A, QXE9, Q1/A, R1/A, SXE/A, S1/A, VXE8, W1/A				
					26		34150-ZH7-003	ALERT UNIT, OIL	1	(1)	-	-----	2440203	LXE/A, QSE/A, QXE/A, QXE9, Q1/A, SXE/A, S1/A, VXE8, WXE8/A
									1	(1)	-	-----	1321603	HEA2, HEA8, L1, PAE2, QAE2, QAE6, Q1, Q2, R1, S1, VDE, VDE2, VKB2 VME2, V1, W1
									1	-	-	-----	-----	HEA2/A, HEA8/A, LXE8/A, PAE2/A, PXE8/A, QAE2/A, QAE6/A QME2/A, QSC9/A, QSE8/A, QXB6/A, QXE4/A, QXE6/A, QXE8/A SME1/A, SXEB/A, SXE4/A, SXE8/A, VDE2/A, VKB2/A, VME2/A, VMS2 VXE8/A, VXE4/A, VXE6/A, VXE7/A, WMA4
									1	-	-	-----	1324182	LXE, LXE8, PXE8, QXE, QXEB, QXE6, QXE8, SXE, SXE8, VEB6, VXE VXE6, VX26, WXE8
					1	-	-	-----	1325170	QME2, SME1				
					1	-	-	-----	1325305	QXE4, SXEB, SXE4, VXE8, VXE4, VXE7				
					1	-	-	-----	1329950	QSC9, QSE, QSE2, QSE8, QXB6				
A		34150-ZH7-013	1	(1)	-	-----	2440204	LXE/A, QSE/A, QXE/A, QXE9, Q1/A, SXE/A, S1/A, VXE8, WXE8/A					
E-23-2	17		34150-ZH7-003	ALERT UNIT, OIL	-	(1)	-	-----	-----	L1/A, R1/A, W1/A				
					-	(1)	-	-----	2440203	Q1/A, S1/A				
					-	(1)	-	-----	1321603	L1, Q1, Q2, R1, S1, V1, W1				
					A		34150-ZH7-013	-	(1)	-	-----	2440204	Q1/A, S1/A
E-26-1	10		92000-08025-0A	BOLT, HEX., 8X25	1	(1)	-	-----	-----	LJ, L1				
					-	(1)	-	-----	2437805	L1/A				
					A		92101-08025-0A	-	(1)	-	-----	2437806	L1/A

NOTE A:PART NO. CHANGE D:NEWLY PROVIDED E:PART NO.DELETION K:REQUIRED NO. CORRECTION L:APPLICATION SERIAL NO. CORRECTION
T:APPLICATION CORRECTION Z:REMARKS CHANGE



PARTS CATALOGUE NEWS

Honda Motor Co., Ltd. Service Division

PARTS CATALOGUE - CORRECTED

Printed in Japan

CODE NO.	BOOKLET TYPE	13ZH90E9
	MICRO- FICHE	13ZH90EI/FI
PARTS CATALOGUE NEWS	GX270 GX270[PROPANE ENGINE]	
NEWS NO.	016	

Block No.	Ref. No.	Note	Part No.	Description	Reqd. QTY			Serial No.	Parts catalogue code
					(1)	(2)	(3)		
E-14-1	8		16100-Z5J-V12	CARBURETOR ASSY. (BE21G B/C) .	1	-	-	----- 2440626	VKK
		A	16100-Z5J-V13	CARBURETOR ASSY. (BE21G C) ...	1	-	-	2440627 -----	VKK
	49		16230-ZE3-701	VALVE ASSY., SOLENOID	1	-	-	-----	ES3, VKE4, VMS2, VMT, VMX2
					1	-	-	----- 2440626	ES3/A, VKK, VMT/A, VS3, VS4
	A		16230-ZE3-702	1	-	-	2440627 -----	ES3/A, VKK, VMT/A, VS3, VS4
E-14-2	16		16230-ZE3-701	VALVE ASSY., SOLENOID	1	-	-	-----	ESS
					1	-	-	----- 2440626	ESS/A
		A		16230-ZE3-702	1	-	-	2440627 -----

NOTE A:PART NO. CHANGE D:NEWLY PROVIDED E:PART NO.DELETION K:REQUIRED NO. CORRECTION L:APPLICATION SERIAL NO. CORRECTION
T:APPLICATION CORRECTION Z:REMARKS CHANGE



PARTS CATALOGUE NEWS

Honda Motor Co., Ltd. Service Division

PARTS CATALOGUE - CORRECTED

Printed in Japan

CODE NO.	BOOKLET TYPE	13ZH90E9
	MICRO-FICHE	13ZH90EI/FI
PARTS CATALOGUE NEWS	GX270 GX270[PROPANE ENGINE]	
NEWS NO.	017	

Block No.	Ref. No.	Note	Part No.	Description	Reqd. QTY			Serial No.	Parts catalogue code
					(1)	(2)	(3)		
E-3	2		15510-ZE2-043	SWITCH ASSY., OIL LEVEL	1	(1)	-	-----	GX270 ESS, ES1, ES3, HA, HAQ, HA2, HA2/A, HEA, HEA2, HEA2/A, HEA8 HEA8/A, HX, HXQ4, HXQ4/A, HX26, HX26/A, HX8, HX8/A, LJC, LJC/A LX, LXE, LXE/A, LXE8, LXE8/A, LXQ4, LXQ4/A, LXU, LXU/A, LXZ LX16, L1, L1/A, PA, PAE2, PAE2/A, PA2, PA2/A, PX, PXE8, PXE8/A PXU, PXU/A, PX26, PX26/A, QA, QAB1, QAB3, QAB3/A, QAE, QAE2 QAE2/A, QAE6, QAE6/A, QAG, QAG/A, QAG2, QAG2/A, QAQ, QAQ4 QAQ4/A, QAR2, QAR2/A, QAW, QAW/A, QA2, QA2/A, QKE3, QKE3/A QKE4, QL2, QME2, QME2/A, QSC, QSC9, QSC9/A, QSE, QSE/A, QSE2 QSE8, QSE8/A, QWA2, QWA4, QWA4/A, QWH2, QWH2/A, QX, QXB, QXB/A QXB6, QXB6/A, QXB7, QXB7/A, QXC, QXC4, QXC4/A, QXC6, QXC6/A QXC9, QXC9/A, QXE, QXE8, QXE8/A, QXE4, QXE4/A, QXE6, QXE6/A, QXE8 QXE8/A, QXQ4, QXQ4/A, QXU, QXU/A, QX26, QX26/A, Q1, Q2, RA, RA2 RA2/A, RSC2, RSC2/A, RX, RXQ4, RXQ4/A, RXU, RXU/A, R1, R1/A SJP, SMC4, SMC4/A, SMD, SME1, SME1/A, SME6, SME6/A, SMX2, SWA4 SWC4, SWC4/A, SX, SXB, SXB/A, SXB7, SXB7/A, SXE, SXE8, SXE8/A SXE4, SXE4/A, SXE8, SXE8/A, SXQ4, SXQ4/A, SXU, SXU/A, SX2, S1 VA, VAG2, VAG2/A, VAW, VAW1, VA2, VA2/A, VDE, VDE2, VDE2/A VD16, VEB6, VKB2, VKB2/A, VKE4, VKX4, VMA4, VME2, VME2/A, VME4 VMS2, VMT, VMX2, VM2, VM2/A, VNG1, VNG1/A, VNT2, VNT2/A, VN17 VN17/A, VPE4, VPE4/A, VPE5, VPE7, VPE7/A, VPX4, VPX4/A, VPX5 VPX7, VPX7/A, VSD, VSD/A, VSD3, VSD3/A, VSD7, VSD7/A, VSH7 VS37, VS37/A, VWA, VWA2, VWA2/A, VWN2, VWN2/A, VWT4, VWT4/A VW12, VW12/A, VW22, VX, VXB, VXB/A, VXB2, VXB6, VXB7, VXB7/A VXE, VXE8, VXE8/A, VXE4, VXE4/A, VXE6, VXE6/A, VXE7, VXE7/A VXG, VXQ4, VXQ4/A, VXTB, VXT1, VXT1/A, VXU, VXU1, VXU1/A, VX26 V1, WMA4, WMT8, WMT8/A, WXE8, WXE8/A, W1, W1/A

NOTE A:PART NO. CHANGE D:NEWLY PROVIDED E:PART NO.DELETION K:REQUIRED NO. CORRECTION L:APPLICATION SERIAL NO. CORRECTION
 T:APPLICATION CORRECTION Z:REMARKS CHANGE

PARTS CATALOGUE NEWS

BOOKNo. : 13ZH90E9

Block No.	Ref. No.	Note	Part No.	Description	Reqd. QTY			Serial No.	Parts catalogue code
					(1)	(2)	(3)		
					1	(1)	-	----- 2438529	ESS/A, ES1/A, ES3/A, HX/A, LX/A, PX/A, QX/A, QXE/A, QXE9, QXK Q1/A, RX/A, SX/A, SXE/A, S1/A, VKK, VMT/A, VPK, VS3, VS4, VX/A VXE8, VXX, VXU/A
					-	-	1		
		A	15510-ZE2-053	1	(1)	-	2438530 -----	ESS/A, ES1/A, ES3/A, HX/A, LX/A, PX/A, QX/A, QXE/A, QXE9, QXK Q1/A, RX/A, SX/A, SXE/A, S1/A, VKK, VMT/A, VPK, VS3, VS4, VX/A VXE8, VXX, VXU/A

NOTE A:PART NO. CHANGE D:NEWLY PROVIDED E:PART NO.DELETION K:REQUIRED NO. CORRECTION L:APPLICATION SERIAL NO. CORRECTION
T:APPLICATION CORRECTION Z:REMARKS CHANGE



PARTS CATALOGUE NEWS

Honda Motor Co., Ltd. Service Division

PARTS CATALOGUE - CORRECTED

Printed in Japan

CODE NO.	BOOKLET TYPE	13ZH90E9
	MICRO- FICHE	13ZH90EI/FI
PARTS CATALOGUE NEWS	GX270 GX270[PROPANE ENGINE]	
NEWS NO.	018	

Block No.	Ref. No.	Note	Part No.	Description	Reqd. QTY			Serial No.	Parts catalogue code
					(1)	(2)	(3)		
E-14-1	16		16260-ZE3-D21	STAY ASSY., MANUAL CHOKE	1	-	-	----- 2438529	VPK
	A		16260-ZE3-D22	1	-	-	2438530 -----	VPK
	24	L	16400-ZE2-703	DIAPHRAGM ASSY.	1	-	-	-----	ES3, VKE4, VKX4, VMT, VPE4, VPE4/A, VPE5, VPE7, VPE7/A, VPX4 VPX4/A, VPX5, VPX7, VPX7/A, VSD3, VSD3/A, VS37, VS37/A
					1	-	-	----- 2438529	VPK
					1	-	-	----- 2440240	ES3/A, VKK, VMT/A, VS3, VS4
	T		16400-ZE2-704	1	-	-	2438530 -----	VPK
					1	-	-	2440241 -----	ES3/A, VKK, VMT/A, VS3, VS4

NOTE A:PART NO. CHANGE D:NEWLY PROVIDED E:PART NO.DELETION K:REQUIRED NO. CORRECTION L:APPLICATION SERIAL NO. CORRECTION
T:APPLICATION CORRECTION Z:REMARKS CHANGE



PARTS CATALOGUE NEWS

Honda Motor Co., Ltd. Service Division

PARTS CATALOGUE - CORRECTED

Printed in Japan

CODE NO.	BOOKLET TYPE	13ZH90E9
	MICRO- FICHE	13ZH90EI/FI
PARTS CATALOGUE NEWS	GX270 GX270[PROPANE ENGINE]	
NEWS NO.	019	

Block No.	Ref. No.	Note	Part No.	Description	Reqd. QTY			Serial No.	Parts catalogue code
					(1)	(2)	(3)		
E-7	3	T	13310-ZH9-820	CRANKSHAFT COMP.	1	-	1	-----	HA, HAP, HAQ, HA2, HEA, HEA2, HEA8, LSS, LTJ, LWD1
					-	-	1	-----	1100192 HAP/A
		T	13310-ZH9-821	1	-	-	-----	HA2/A, HEA2/A, HEA8/A, LWD1/A
					-	-	1	1100193	HAP/A
	6	T	13310-ZK9-670	CRANKSHAFT COMP.	1	-	-	-----	VN17, VPE7, VPX7, VSD7, VS37, VXB7, VXE7
					1	-	-	-----	2135204 VXB7/A, VXE7/A
		D	13310-ZK9-671	1	-	-	-----	VN17/A, VPE7/A, VPX7/A, VSD7/A, VSH7, VS37/A

NOTE A:PART NO. CHANGE D:NEWLY PROVIDED E:PART NO.DELETION K:REQUIRED NO. CORRECTION L:APPLICATION SERIAL NO. CORRECTION
T:APPLICATION CORRECTION Z:REMARKS CHANGE



PARTS CATALOGUE NEWS

Honda Motor Co., Ltd. Service Division

PARTS CATALOGUE - CORRECTED

Printed in Japan

CODE NO.	BOOKLET TYPE	13ZH90E9
	MICRO- FICHE	13ZH90EI/FI
PARTS CATALOGUE NEWS	GX270 GX270[PROPANE ENGINE]	
NEWS NO.	020	

Block No.	Ref. No.	Note	Part No.	Description	Reqd. QTY			Serial No.	Parts catalogue code	
					(1)	GX270 (2)	(3)			
E-14-1	55		36170-ZB4-003	VALVE ASSY., SOLENOID	1	-	-	-----	VKE4	
					1	-	-	-----	2440626	VKK
					1	-	-	2440627	-----	VKK
E-40-10	25		16500-ZE2-702	SWITCH, THERMO	1	-	-	-----	2440626	VKK
					1	-	-	2440627	-----	VKK

NOTE A:PART NO. CHANGE D:NEWLY PROVIDED E:PART NO.DELETION K:REQUIRED NO. CORRECTION L:APPLICATION SERIAL NO. CORRECTION
T:APPLICATION CORRECTION Z:REMARKS CHANGE



PARTS CATALOGUE NEWS

Honda Motor Co., Ltd. Service Division

PARTS CATALOGUE - CORRECTED

Printed in Japan

CODE NO.	BOOKLET TYPE	13ZH90E9
	MICRO-FICHE	13ZH90EI/FI
PARTS CATALOGUE NEWS	GX270 GX270[PROPANE ENGINE]	
NEWS NO.	021	

Block No.	Ref. No.	Note	Part No.	Description	Reqd. QTY			Serial No.		Parts catalogue code	
					(1)	(2)	(3)				
E-14-1	16	L	16260-ZE2-730	STAY ASSY., MANUAL CHOKE	1	-	-	2207391	2341615	VKX4, VPE4/A, VPE5, VPX4/A, VPX5, VS37/A	
			T	16260-ZE3-D21	1	-	-	-----	2438529	VPK
						1	-	-	2341616	-----	VKX4, VPE4/A, VPE5, VPX4/A, VPX5, VS37/A
E-28	17	L	87532-ZH8-810	MARK, OIL ALERT (EXTERNAL) ...	1	(1)	1	-----	-----	ES1, ES1/A, HAP, HAP/A, HAQ, HA2, HA2/A, HEA, HEA2, HEA2/A, HEA8, HEA8/A, HX/A, HX26, HX26/A, HX8, HX8/A, LX/A, LXE, LXE/A, LXE8, LXE8/A, LXU, LXU/A, LX16, L1/A, PAE2, PAE2/A, PA2, PA2/A, PX/A, PXE8, PXE8/A, PXU, PXU/A, PX26, PX26/A, QAB1, QAB3, QAB3/A, QAE, QAE2, QAE2/A, QAE6, QAE6/A, QAG, QAG/A, QAG2, QAG2/A, QAQ, QAR2, QAR2/A, QAW, QA2, QKE4, QL2, QSC, QSC9, QSC9/A, QSE, QSE/A, QSE2, QSE8, QSE8/A, QWA2, QWA4, QWA4/A, QWH2, QWH2/A, QX/A, QXB6, QXB6/A, QXC6, QXC6/A, QXC9, QXE/A, QXE6, QXE6/A, QXE8, QXE8/A, QXU, QXU/A, QX26, QX26/A, Q1/A, Q2, RA2, RA2/A, RSC2, RSC2/A, RX/A, RXU, RXU/A, R1/A, SMD, SMX2, SWC4/A, SX/A, SXE/A, SXE8, SXE8/A, SXU, SXU/A, SX2, VAW1, VA2, VA2/A, VDE, VDE2, VDE2/A, VD16, VEB6, VKB2, VKB2/A, VME2, VME2/A, VM2, VM2/A, VNT2, VNT2/A, VWN2, VWN2/A, VW12, VW12/A, VW22, VX/A, VXB2, VXB6, VXE6, VXE6/A, VXU, VXU/A, VXU1, VXU1/A, VX26, WMT8, WMT8/A, WXE8, WXE8/A, W1/A	
			1	(1)	-		1033680	-----	HA, HX, LX, LXZ, L1, PA, PX, QA, QX, QXC, QXE, QXEB, Q1, RA, RX, R1, SX, SXE, VA, VAW, VX, VXE, V1, W1		
			1	-	-		-----	1106273	VSD3, VXG		

NOTE A:PART NO. CHANGE D:NEWLY PROVIDED E:PART NO.DELETION K:REQUIRED NO. CORRECTION L:APPLICATION SERIAL NO. CORRECTION
T:APPLICATION CORRECTION Z:REMARKS CHANGE

PARTS CATALOGUE NEWS

BOOKNo. : 13ZH90E9

Block No.	Ref. No.	Note	Part No.	Description	Reqd. QTY			Serial No.	Parts catalogue code
					(1)	(2)	(3)		
					1	-	-	----- 2373000	QAW/A, QA2/A, QXC9/A
					1	-	-	1033680 1106273	QXB, SXB, SXEB, VNG1, VSD, VXB, VXEB
					1	-	-	1340170 -----	SWC4
	30	L	87135-ZE2-020	LABEL, E-SPEC (15. 5X27. 5)	1	1	-	----- -----	L1, R1, SME1, SWA4, S1
					1	1	-	----- 2406429	ESS/A, ES1/A, HX/A, HX8/A, LH/A, LHB5, LHE/A, LJ/A, LJC/A LJG/A, LT/A, LW/A, LWD1/A, LX/A, LXE/A, LXE8/A, LXU/A, L1/A PX/A, PXE8/A, PXU/A, QAB3/A, QD/A, QH/A, QHB5, QHP1/A, QHZ/A QMH/A, QP/A, QSE/A, QSE8/A, QX/A, QXE/A, QXE8/A, QXU/A, Q1/A RD/A, RSS/A, RX/A, RXU/A, R1/A, SD/A, SH/A, SJ/A, SJG/A, SX/A SXE/A, SXE8/A, SXU/A, S1/A, VX/A, VXU/A, VXU1/A, WMT8/A WXE8/A, W1/A
					1	-	-	----- 2297651	HXQ4/A, LXQ4/A, QAQ4/A, QE/A, QHE4/A, QHQ4/A, QHR/A, QHR4/A QKE3/A, QME2/A, QXB/A, QXB7/A, QXC4/A, QXE4/A, QXQ4/A RHE4/A, RHQ4/A, RXQ4/A, SE/A, SHQ4/A, SMC4/A, SME1/A, SME6/A SXB/A, SXB7/A, SXEB/A, SXE4/A, SXQ4/A, VPX7/A, VSD/A, VSD7/A VSH7, VS37/A, VXB/A, VXB7/A, VXEB/A, VXE4/A, VXE7/A, VXQ4/A
					1	-	-	1841643 -----	RHE4
					-	-	1	----- 1100192	RXP/A, VXP/A

NOTE A:PART NO. CHANGE D:NEWLY PROVIDED E:PART NO.DELETION K:REQUIRED NO. CORRECTION L:APPLICATION SERIAL NO. CORRECTION
T:APPLICATION CORRECTION Z:REMARKS CHANGE



PARTS CATALOGUE NEWS

Honda Motor Co., Ltd. Service Division

CODE NO.	BOOKLET TYPE	13ZH90E9
	MICRO- FICHE	13ZH90EI/FI
PARTS CATALOGUE NEWS	GX270 GX270[PROPANE ENGINE]	
NEWS NO.	022	

Printed in Japan

GX270-ES4,RA3 AND VS5 TYPES sales parts information

NOTE: This Parts Catalogue News explains only the parts of the different model that are produced to conform to addition of the GX270-ES4,RA3 and VS5 types.

As for the parts not listed on this Parts Catalogue News, use the parts of the GX270-ES3/A,RA2/A and VS4 types.

Models, parts catalogue codes and applicable serial numbers

Model	Type		Parts catalogue type	Applicable engine serial No.	Applicable carburetor identification No.
GX270	ES3/A	Base type	ES3/A	GCAB-2000001~	BE77M A
	ES4	Additional type	ES4		
	RA2/A	Base type	RA2/A	GCAB-2000001~9999999	BE75B B / C
	RA3	Additional type	RA3		
	VS4	Base type	VS4	GCAB-2000001~	BE77M A
	VS5	Additional type	VS5		

•Features of each type		Base type	Additional type	Base type	Additional type	Base type	Additional type
Specifications	Model	GX270					
	Type	Standard equipment (1)					
		ES3/A	ES4	RA2/A	RA3	VS4	VS5
Crankshaft	25mm Ø Straight			●	●		
	25.4mm Ø Straight						
	20mm Ø Spline						
	M20 Stepped thread						
	1" Thread						
	M10 Tapered	●	●				
	5/16" Tapered					●	●
Reduction	1/2 Reduction						
	1/2 Reduction (With clutch)			●	●		
	1/6 Reduction						
Coil	Lamp coil						
	Charge coil						
Fuel tank				●	●		
Control box							
Starter motor							
Oil alert		●	●	●	●	●	●

PARTS CATALOGUE NEWS

BOOKNo. : 13ZH90E9

Block No.	Ref. No.	Part No.	Description	Reqd. QTY			Base Part No.	Parts catalogue code
				(1)	GX270 (2)	(3)		
E-2	16	95701-10080-00	BOLT, FLANGE, 10X80	4	-	-	95725-10080-00	RA3
E-3	2	15510-ZE2-053	SWITCH ASSY., OIL LEVEL	1	-	-	15510-ZE2-043	RA3
	16	34150-ZH7-013	ALERT UNIT, OIL	1	-	-	34150-ZH7-003	RA3
E-8	1		RING SET, PISTON (STD.) (NIPPON)	0	-	-	13010-ZE8-601	
			RING SET, PISTON (0.25) (NIPPON)	(0)	-	-	13011-ZE8-601	
			RING SET, PISTON (0.50) (NIPPON)	(0)	-	-	13012-ZE8-601	
			RING SET, PISTON (0.75) (NIPPON)	(0)	-	-	13013-ZE8-601	
		13010-Z5H-004	RING SET, PISTON (STD.) (TEIKOKU)	1	-	-	13010-ZE8-602	
		13011-Z5H-004	RING SET, PISTON (0.25) (TEIKOKU)	(1)	-	-	13011-ZE8-602	
		13012-Z5H-004	RING SET, PISTON (0.50) (TEIKOKU)	(1)	-	-	13012-ZE8-602	
		13013-Z5H-004	RING SET, PISTON (0.75) (TEIKOKU)	(1)	-	-	13013-ZE8-602	
	2	13101-ZH9-010	PISTON (STD.)	1	-	-	13101-ZH9-000	
		13102-ZH9-010	PISTON (0.25)	(1)	-	-	13102-ZH9-000	
		13103-ZH9-010	PISTON (0.50)	(1)	-	-	13103-ZH9-000	
		13104-ZH9-010	PISTON (0.75)	(1)	-	-	13104-ZH9-000	
E-12	5	19610-ZE2-010ZF	COVER COMP., FAN *NH246*..... LOOSEY GRAY	1	-	-		RA3
	11	36100-ZF6-P82	SWITCH ASSY., ENGINE STOP	1	-	-	36100-ZH7-003	RA3
	22		CLIP, HARNESS	0	-	-	90684-ZA0-601	RA3
E-15-5	12		NUT, FLANGE, 6MM	0	-	-	94050-06080	ES4, VS5

PARTS CATALOGUE NEWS

BOOKNo. : 13ZH90E9

Block No.	Ref. No.	Part No.	Description	Reqd. QTY			Base Part No.	Parts catalogue code
				(1)	GX270 (2)	(3)		
E-28	3		EMBLEM (GX270)	0	-	-	87521-ZH9-040	ES4
		87521-ZH9-040	1	-	-	87521-ZH9-030	RA3
	7		LABEL, CAUTION (ENGLISH, ETC.)	0	-	-	87522-ZH9-010	RA3
	10	87528-ZH7-000	MARK, CHOKE (GRAY)	1	-	-	87528-ZE2-810	RA3
	12		MARK, CHOKE	0	-	-	87528-898-620	ES4
	16	87532-ZH7-000	MARK, THROTTLE INDICATION	1	-	-		RA3
	17		MARK, OIL ALERT (EXTERNAL) ...	0	-	-	87532-ZH8-810	RA3
	25		MARK, AIR CLEANER	0	-	-	87533-ZC0-630	ES4
	26		MARK, EX. CAUTION (ENGLISH/FRENCH)	0	-	-	87539-898-620	ES4
	33		MARK, OPERATOR CAUTION	0	-	-	87516-ZM7-801	VS5
	34	87516-Z0D-800	MARK, OPERATOR CAUTION	1	-	-		RA3
	35	87516-Z0D-800	MARK, OPERATOR CAUTION	1	-	-		ES4, VS5
E-29	8	89218-ZE1-000	WRENCH COMP., SPARK PLUG	(1)	-	-	89218-ZE1-000	RA3
	21	98079-55846	PLUG, SPARK (BPR5ES) (NGK)	1	-	-	98079-55846	VS5

Block No.	Ref. No.	Part No.	Description	Reqd. QTY			Base Part No.	Parts catalogue code
				(1)	(2)	(3)		

E-40-10 OTHER PARTS (EMERGENCY STOP SWITCH)

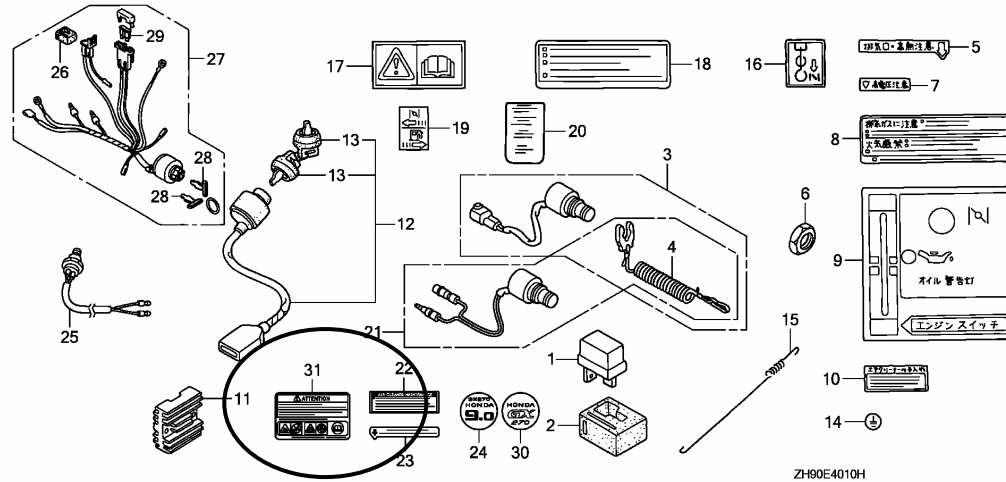

ZH90E4010H

E-40-10	16	87528-898-620	MARK, CHOKE	1	-	-	ES4
	22	87533-ZC0-630	MARK, AIR CLEANER	1	-	-	ES4
	23	87539-898-620	MARK, EX. CAUTION (ENGLISH/FRENCH)	1	-	-	ES4
	30	87521-ZH9-040	EMBLEM (GX270)	1	-	-	ES4
	31	87516-ZH7-800	MARK, OPERATOR CAUTION (FRENCH) (MADE IN JAPAN)	1	-	-	RA3



PARTS CATALOGUE NEWS

Honda Motor Co., Ltd. Service Division

PARTS CATALOGUE - CORRECTED

Printed in Japan

CODE NO.	BOOKLET TYPE	13ZH90E9
	MICRO-FICHE	13ZH90EI/FI
PARTS CATALOGUE NEWS	GX270 GX270[PROPANE ENGINE]	
NEWS NO.	023	

Block No.	Ref. No.	Note	Part No.	Description	Reqd. QTY			Serial No.	Parts catalogue code				
					(1)	(2)	(3)						
E-12	11	L	36100-ZF6-P81	SWITCH ASSY., ENGINE STOP	1	-	-	-----	VPX5				
					1	-	-	-----	2449125	QXK			
					1	-	-	2372801	-----	QAW/A, QA2/A, QXC9/A			
					1	-	-	2375750	-----	QWA4/A, SWC4/A			
			T	36100-ZF6-P82	1	-	-	-----	RA3			
					1	-	-	2449126	-----	QXK			
E-23-1	2		31610-Z5K-801ZA	BOX ASSY., CONTROL (EXP-ALERT) *R280* POWER RED	1	-	-	-----	2451486	VXE8			
					1	-	-	-----	2451486	VXE8			
						31610-Z5K-801ZB	*NH1* BLACK	1	-	-	-----	2451486	VXE8
			A	31610-Z5K-802ZA	*R280* POWER RED	1	-	-	2451487	-----	VXE8		
			A	31610-Z5K-802ZB	*NH1* BLACK	1	-	-	2451487	-----	VXE8		
	10		35100-ZE2-842	SWITCH ASSY., COMBINATION (3A-CHARGE)	1	(1)	-	-----	-----	HEA, HEA2, HEA2/A, HEA8, HEA8/A, L1, PAE2, PAE2/A, QAE, QAE2 QAE2/A, QAE6, QAE6/A, Q1, Q2, R1, VDE, VDE2, VDE2/A, VKB2 VKB2/A, VKE4, VME2, VME2/A, VMS2, V1, W1			

NOTE A:PART NO. CHANGE D:NEWLY PROVIDED E:PART NO.DELETION K:REQUIRED NO. CORRECTION L:APPLICATION SERIAL NO. CORRECTION
T:APPLICATION CORRECTION Z:REMARKS CHANGE

PARTS CATALOGUE NEWS

BOOKNo. : 13ZH90E9

Block No.	Ref. No.	Note	Part No.	Description	Reqd. QTY			Serial No.	Parts catalogue code
					(1)	(2)	(3)		
		A	35100-ZE2-843	-	(1)	-	----- 2451486	L1/A, Q1/A, R1/A, W1/A
E-40-10	27		35100-ZE2-842	SWITCH ASSY., COMBINATION (3A-CHARGE)	1	-	-	----- 2451486	VKK
		A	35100-ZE2-843	1	-	-	2451487 -----	VKK

NOTE A:PART NO. CHANGE D:NEWLY PROVIDED E:PART NO.DELETION K:REQUIRED NO. CORRECTION L:APPLICATION SERIAL NO. CORRECTION
T:APPLICATION CORRECTION Z:REMARKS CHANGE



PARTS CATALOGUE NEWS

Honda Motor Co., Ltd. Service Division

PARTS CATALOGUE - CORRECTED

Printed in Japan

CODE NO.	BOOKLET TYPE	13ZH90E9
	MICRO- FICHE	13ZH90EI/FI
PARTS CATALOGUE NEWS	GX270 GX270[PROPANE ENGINE]	
NEWS NO.	024	

Block No.	Ref. No.	Note	Part No.	Description	Reqd. QTY			Serial No.	Parts catalogue code
					(1)	(2)	(3)		
E-23-2	5		31620-ZG5-023	RECTIFIER ASSY., REGULATOR (20A)	-	(1)	-	2437500 ----- W1/A	
					-	(1)	-	2437500 2454910 L1/A, Q1/A, R1/A, S1/A	
		A	31620-ZG5-033	-	(1)	-	2454911 ----- L1/A, Q1/A, R1/A, S1/A	

NOTE A:PART NO. CHANGE D:NEWLY PROVIDED E:PART NO.DELETION K:REQUIRED NO. CORRECTION L:APPLICATION SERIAL NO. CORRECTION
T:APPLICATION CORRECTION Z:REMARKS CHANGE



PARTS CATALOGUE NEWS

Honda Motor Co., Ltd. Service Division

PARTS CATALOGUE - CORRECTED

Printed in Japan

CODE NO.	BOOKLET TYPE	13ZH90E9
	MICRO- FICHE	13ZH90EI/FI
PARTS CATALOGUE NEWS	GX270 GX270[PROPANE ENGINE]	
NEWS NO.	025	

Block No.	Ref. No.	Note	Part No.	Description	Reqd. QTY			Serial No.	Parts catalogue code
					(1)	(2)	(3)		
E-28	34	E	87516-Z0D-800	*PARTS NO. DELETION					
	35	T	87516-Z0D-800	MARK, OPERATOR CAUTION	1	-	-	-----	ES4, RA3, VS5

NOTE A:PART NO. CHANGE D:NEWLY PROVIDED E:PART NO.DELETION K:REQUIRED NO. CORRECTION L:APPLICATION SERIAL NO. CORRECTION
T:APPLICATION CORRECTION Z:REMARKS CHANGE



PARTS CATALOGUE NEWS

Honda Motor Co., Ltd. Service Division

PARTS CATALOGUE - CORRECTED

Printed in Japan

CODE NO.	BOOKLET TYPE	13ZH90E9
	MICRO-FICHE	13ZH90EI/FI
PARTS CATALOGUE NEWS	GX270 GX270[PROPANE ENGINE]	
NEWS NO.	026	

Block No.	Ref. No.	Note	Part No.	Description	Reqd. QTY			Serial No.	Parts catalogue code
					(1)	(2)	(3)		
E-28	31	T	87114-ZH7-000	LABEL, WARNING (NOT CERTIFIED FOR SALE)	1	1	-	2359274 -----	HX/A, LHB5, LJ/A, LJC/A, LJG/A, LT/A, LWD1/A, LX/A, L1/A, PX/A, QAB3/A, QD/A, QHB5, QHP1/A, QHZ/A, QMH/A, QP/A, QT/A, QX/A, QXE/A, Q1/A, RD/A, RSS/A, RX/A, R1/A, SD/A, SJG/A, SN/A, SX/A, SXE/A, S1/A, VMT/A, VX/A, VXT1/A, W1/A
					1	-	-	-----	ES4, QXE9, QXK, RA3, VKK, VPK, VS4, VS5, VXE8, VXK
					1	-	-	2397962 -----	VS3
					1	-	-	2401383 -----	ESS/A, ES1/A, ES3/A, LH/A, LHE/A, LW/A, LXE/A, QH/A, QSE/A, SH/A, SJ/A, VXU/A, WMT8/A, WXE8/A

NOTE A:PART NO. CHANGE D:NEWLY PROVIDED E:PART NO.DELETION K:REQUIRED NO. CORRECTION L:APPLICATION SERIAL NO. CORRECTION
T:APPLICATION CORRECTION Z:REMARKS CHANGE



PARTS CATALOGUE NEWS

Honda Motor Co., Ltd. Service Division

PARTS CATALOGUE - CORRECTED

Printed in Japan

CODE NO.	BOOKLET TYPE	13ZH90E9
	MICRO- FICHE	13ZH90EI/FI
PARTS CATALOGUE NEWS	GX270 GX270[PROPANE ENGINE]	
NEWS NO.	027	

Block No.	Ref. No.	Note	Part No.	Description	Reqd. QTY			Serial No.	Parts catalogue code
					(1)	(2)	(3)		
E-22-10	6		36160-ZB4-003	SOLENOID ASSY.	1	-	-	-----	VAG2, VAG2/A, VMS2, VMT
								-----	2458001
	A		36160-ZB4-013	1	-	-	2458002	VMT/A

NOTE A:PART NO. CHANGE D:NEWLY PROVIDED E:PART NO.DELETION K:REQUIRED NO. CORRECTION L:APPLICATION SERIAL NO. CORRECTION
T:APPLICATION CORRECTION Z:REMARKS CHANGE

April 06, 2008



PARTS CATALOGUE NEWS

Honda Motor Co., Ltd. Service Division

PARTS CATALOGUE - CORRECTED

Printed in Japan

CODE NO.	BOOKLET TYPE	13ZH90E9
	MICRO- FICHE	13ZH90E1/FI
PARTS CATALOGUE NEWS	GX270 GX270[PROPANE ENGINE]	
NEWS NO.	028	

NOTE A:PART NO. CHANGE D:NEWLY PROVIDED E:PART NO.DELETION K:REQUIRED NO. CORRECTION L:APPLICATION SERIAL NO. CORRECTION
T:APPLICATION CORRECTION Z:REMARKS CHANGE

PARTS CATALOGUE NEWS

BOOKNo. : 13ZH90E9

Block No.	Ref. No.	Note	Part No.	Description	Reqd. QTY			Serial No.	Parts catalogue code
					(1)	(2)	(3)		
E-8	1	L	13010-ZE8-601	RING SET, PISTON (STD.) (NIPPON)	1	1	-	-----	<p>ESS, ES1, ES3, HA, HAQ, HA2, HA2/A, HEA, HEA2, HEA2/A, HEA8, HEA8/A, HH, HX, HXQ4, HXQ4/A, HX26, HX26/A, HX8, HX8/A, LH, LHB1, LHB3, LHE, LHQ4, LJ, LJC, LJC/A, LJG, LSS, LT, LTJ, LW, LWD, LWD1, LX, LXE, LXE8, LXE8/A, LXQ4, LXQ4/A, LXU, LXU/A, LXZ, LX16, L1, PA, PAE2, PAE2/A, PA2, PA2/A, PX, PXE8, PXE8/A, PXU, PXU/A, PX26, PX26/A, QA, QAB1, QAB3, QAE, QAE2, QAE2/A, QAE6, QAE6/A, QAG, QAG/A, QAG2, QAG2/A, QAQ, QAQ4, QAQ4/A, QAR2, QAR2/A, QAW, QAW/A, QA2, QA2/A, QD, QE, QE/A, QH, QHC, QHE, QHE4, QHE4/A, QHP1, QHQ4, QHQ4/A, QHR, QHR/A, QHR4, QHR4/A, QHZ, QH26, QH26/A, QKE3, QKE3/A, QKE4, QL2, QME2, QME2/A, QMH, QP, QSC, QSC9, QSC9/A, QSE, QSE2, QSE8, QSE8/A, QT, QWA2, QWA4, QWA4/A, QWH2, QWH2/A, QX, QXB, QXB/A, QXB6, QXB6/A, QXB7, QXB7/A, QXC, QXC4, QXC4/A, QXC6, QXC6/A, QXC9, QXC9/A, QXE, QXE8, QXE8/A, QXE4, QXE4/A, QXE6, QXE6/A, QXE8, QXE8/A, QXQ4, QXQ4/A, QXU, QXU/A, QX26, QX26/A, Q1, Q2, RA, RA2, RA2/A, RD, RH, RHE, RHE4, RHE4/A, RHQ4, RHQ4/A, RH26, RH26/A, RSC2, RSC2/A, RSS, RX, RXQ4, RXQ4/A, RXU, RXU/A, R1, SD, SE, SE/A, SH, SHE, SHEZ, SHQ4, SHQ4/A, SJ, SJG, SJP, SK, SKE1, SMC4, SMC4/A, SMD, SME1, SME1/A, SME6, SME6/A, SMX2, SN, SW, SWA4, SWC4, SWC4/A, SWE, SX, SXB, SXB/A, SXB7, SXB7/A, SXE, SXEB, SXEB/A, SXE4, SXE4/A, SXE8, SXE8/A, SXQ4, SXQ4/A, SXU, SXU/A, SX2, S1, VA, VAG2, VAG2/A, VAW, VAW1, VA2, VA2/A, VDE, VDE2, VDE2/A, VD16, VEB6, VH, VKB2, VKB2/A, VKE4, VKX4, VMA4, VME2, VME2/A, VME4, VMS2, VMT, VMT2, VMT2/A, VNG1, VNG1/A, VNT2, VNT2/A, VN17, VN17/A, VPE4, VPE4/A, VPE5, VPE7, VPE7/A, VPX4, VPX4/A, VPX5, VPX7, VPX7/A, VSD, VSD/A, VSD3, VSD3/A, VSD7, VSD7/A, VSH7, VS37, VS37/A, VWA, VWA2, VWA2/A, VWN2, VWN2/A, VWT4, VWT4/A, VW12, VW12/A, VW22, VX, VXB, VXB/A, VXB2, VXB6, VXB7, VXB7/A, VXE, VXE8, VXE8/A, VXE4, VXE4/A, VXE6, VXE6/A, VXE7, VXE7/A, VXG, VXQ4, VXQ4/A, VXTB, VXT1, VXT1/A, VXU, VXU1, VXU1/A, VX26, V1, WMA4, WMT8, WXE8, W1</p>
					1	1	-	----- 2456210	<p>ESS/A, ES1/A, ES3/A, HX/A, LH/A, LHB5, LHE/A, LJ/A, LJG/A, LT/A, LW/A, LWD1/A, LX/A, LXE/A, L1/A, PX/A, QAB3/A, QD/A, QH/A, QHB5, QHP1/A, QHZ/A, QMH/A, QP/A, QSE/A, QT/A, QX/A, QXE/A, QXE9, QXK, Q1/A, RD/A, RSS/A, RX/A, R1/A, SD/A, SH/A, SJ/A, SJG/A, SN/A, SX/A, SXE/A, S1/A, VKK, VMT/A, VPK, VS3, VS4, VX/A, VXE8, VXE8/A, VXE4, VXE4/A, VXE6, VXE6/A, VXE7, VXE7/A, W1/A</p>
					-	-	1		

NOTE A:PART NO. CHANGE D:NEWLY PROVIDED E:PART NO.DELETION K:REQUIRED NO. CORRECTION L:APPLICATION SERIAL NO. CORRECTION
T:APPLICATION CORRECTION Z:REMARKS CHANGE

PARTS CATALOGUE NEWS

BOOKNo. : 13ZH90E9

Block No.	Ref. No.	Note	Part No.	Description	Reqd. QTY			Serial No.	Parts catalogue code
					(1)	(2)	(3)		
		L	13010-ZE8-602	RING SET, PISTON (STD.) (TEIKOKU)	1	1	-	-----	ESS, ES1, ES3, HA, HAQ, HA2, HA2/A, HEA, HEA2, HEA2/A, HEA8 HEA8/A, HH, HX, HXQ4, HXQ4/A, HX26, HX26/A, HX8, HX8/A, LH LHB1, LHB3, LHE, LHQ4, LJ, LJC, LJC/A, LJG, LSS, LT, LTJ, LW, LWD LWD1, LX, LXE, LXE8, LXE8/A, LXQ4, LXQ4/A, LXU, LXU/A, LXZ LX16, L1, PA, PAE2, PAE2/A, PA2, PA2/A, PX, PXE8, PXE8/A, PXU PXU/A, PX26, PX26/A, QA, QAB1, QAB3, QAE, QAE2, QAE2/A, QAE6 QAE6/A, QAG, QAG/A, QAG2, QAG2/A, QAQ, QAQ4, QAQ4/A, QAR2 QAR2/A, QAW, QAW/A, QA2, QA2/A, QD, QE, QE/A, QH, QHC, QHE, QHE4 QHE4/A, QHP1, QHQ4, QHQ4/A, QHR, QHR/A, QHR4, QHR4/A, QHZ QH26, QH26/A, QKE3, QKE3/A, QKE4, QL2, QME2, QME2/A, QMH, QP QSC, QSC9, QSC9/A, QSE, QSE2, QSE8, QSE8/A, QT, QWA2, QWA4 QWA4/A, QWH2, QWH2/A, QX, QXB, QXB/A, QXB6, QXB6/A, QXB7 QXB7/A, QXC, QXC4, QXC4/A, QXC6, QXC6/A, QXC9, QXC9/A, QXE QXEB, QXE4, QXE4/A, QXE6, QXE6/A, QXE8, QXE8/A, QXQ4, QXQ4/A QXU, QXU/A, QX26, QX26/A, Q1, Q2, RA, RA2, RA2/A, RD, RH, RHE RHE4, RHE4/A, RHQ4, RHQ4/A, RH26, RH26/A, RSC2, RSC2/A, RSS RX, RXQ4, RXQ4/A, RXU, RXU/A, R1, SD, SE, SE/A, SH, SHE, SHEZ SHQ4, SHQ4/A, SJ, SJG, SJP, SK, SKE1, SMC4, SMC4/A, SMD, SME1 SME1/A, SME6, SME6/A, SMX2, SN, SW, SWA4, SWC4, SWC4/A, SWE, SX SXB, SXB/A, SXB7, SXB7/A, SXE, SXEB, SXEB/A, SXE4, SXE4/A SXE8, SXE8/A, SXQ4, SXQ4/A, SXU, SXU/A, SX2, S1, VA, VAG2 VAG2/A, VAW, VAW1, VA2, VA2/A, VDE, VDE2, VDE2/A, VD16, VEB6 VH, VKB2, VKB2/A, VKE4, VKX4, VMA4, VME2, VME2/A, VME4, VMS2 VMT, VMX2, VM2, VM2/A, VNG1, VNG1/A, VNT2, VNT2/A, VN17 VN17/A, VPE4, VPE4/A, VPE5, VPE7, VPE7/A, VPX4, VPX4/A, VPX5 VPX7, VPX7/A, VSD, VSD/A, VSD3, VSD3/A, VSD7, VSD7/A, VSH7 VS37, VS37/A, VWA, VWA2, VWA2/A, VWN2, VWN2/A, VWT4, VWT4/A VW12, VW12/A, VW22, VX, VXB, VXB/A, VXB2, VXB6, VXB7, VXB7/A VXE, VXE8, VXE8/A, VXE4, VXE4/A, VXE6, VXE6/A, VXE7, VXE7/A VXG, VXQ4, VXQ4/A, VXTB, VXT1, VXT1/A, VXU, VXU1, VXU1/A, VX26 V1, WMA4, WMT8, WXE8, W1
					1	1	-	-----	2456210 ESS/A, ES1/A, ES3/A, HX/A, LH/A, LHB5, LHE/A, LJ/A, LJG/A LT/A, LW/A, LWD1/A, LX/A, LXE/A, L1/A, PX/A, QAB3/A, QD/A QH/A, QHB5, QHP1/A, QHZ/A, QMH/A, QP/A, QSE/A, QT/A, QX/A QXE/A, QXE9, QXK, Q1/A, RD/A, RSS/A, RX/A, R1/A, SD/A, SH/A SJ/A, SJG/A, SN/A, SX/A, SXE/A, S1/A, VKK, VMT/A, VPK, VS3, VS4 VX/A, VXE8, VXK, VXU/A, WMT8/A, WXE8/A, W1/A
					-	-	1		

NOTE A:PART NO. CHANGE D:NEWLY PROVIDED E:PART NO.DELETION K:REQUIRED NO. CORRECTION L:APPLICATION SERIAL NO. CORRECTION
 T:APPLICATION CORRECTION Z:REMARKS CHANGE

PARTS CATALOGUE NEWS

BOOKNo. : 13ZH90E9

Block No.	Ref. No.	Note	Part No.	Description	Reqd. QTY			Serial No.	Parts catalogue code
					(1)	(2)	(3)		
		L	13011-ZE8-601	RING SET, PISTON (0.25) (NIPPON)	(1)	(1)	-	-----	ESS, ES1, ES3, HA, HAQ, HA2, HA2/A, HEA, HEA2, HEA2/A, HEA8 HEA8/A, HH, HX, HXQ4, HXQ4/A, HX26, HX26/A, HX8, HX8/A, LH LHB1, LHB3, LHE, LHQ4, LJ, LJC, LJC/A, LJG, LSS, LT, LTJ, LW, LWD LWD1, LX, LXE, LXE8, LXE8/A, LXQ4, LXQ4/A, LXU, LXU/A, LXZ LX16, L1, PA, PAE2, PAE2/A, PA2, PA2/A, PX, PXE8, PXE8/A, PXU PXU/A, PX26, PX26/A, QA, QAB1, QAB3, QAE, QAE2, QAE2/A, QAE6 QAE6/A, QAG, QAG/A, QAG2, QAG2/A, QAQ, QAQ4, QAQ4/A, QAR2 QAR2/A, QAW, QAW/A, QA2, QA2/A, QD, QE, QE/A, QH, QHC, QHE, QHE4 QHE4/A, QHP1, QHQ4, QHQ4/A, QHR, QHR/A, QHR4, QHR4/A, QHZ QH26, QH26/A, QKE3, QKE3/A, QKE4, QL2, QME2, QME2/A, QMH, QP QSC, QSC9, QSC9/A, QSE, QSE2, QSE8, QSE8/A, QT, QWA2, QWA4 QWA4/A, QWH2, QWH2/A, QX, QXB, QXB/A, QXB6, QXB6/A, QXB7 QXB7/A, QXC, QXC4, QXC4/A, QXC6, QXC6/A, QXC9, QXC9/A, QXE QXEB, QXE4, QXE4/A, QXE6, QXE6/A, QXE8, QXE8/A, QXQ4, QXQ4/A QXU, QXU/A, QX26, QX26/A, Q1, Q2, RA, RA2, RA2/A, RD, RH, RHE RHE4, RHE4/A, RHQ4, RHQ4/A, RH26, RH26/A, RSC2, RSC2/A, RSS RX, RXQ4, RXQ4/A, RXU, RXU/A, R1, SD, SE, SE/A, SH, SHE, SHEZ SHQ4, SHQ4/A, SJ, SJG, SJP, SK, SKE1, SMC4, SMC4/A, SMD, SME1 SME1/A, SME6, SME6/A, SMX2, SN, SW, SWA4, SWC4, SWC4/A, SWE, SX SXB, SXB/A, SXB7, SXB7/A, SXE, SXEB, SXEB/A, SXE4, SXE4/A SXE8, SXE8/A, SXQ4, SXQ4/A, SXU, SXU/A, SX2, S1, VA, VAG2 VAG2/A, VAW, VAW1, VA2, VA2/A, VDE, VDE2, VDE2/A, VD16, VEB6 VH, VKB2, VKB2/A, VKE4, VKX4, VMA4, VME2, VME2/A, VME4, VMS2 VMT, VMX2, VM2, VM2/A, VNG1, VNG1/A, VNT2, VNT2/A, VN17 VN17/A, VPE4, VPE4/A, VPE5, VPE7, VPE7/A, VPX4, VPX4/A, VPX5 VPX7, VPX7/A, VSD, VSD/A, VSD3, VSD3/A, VSD7, VSD7/A, VSH7 VS37, VS37/A, VWA, VWA2, VWA2/A, VWN2, VWN2/A, VWT4, VWT4/A VW12, VW12/A, VW22, VX, VXB, VXB/A, VXB2, VXB6, VXB7, VXB7/A VXE, VXEB, VXEB/A, VXE4, VXE4/A, VXE6, VXE6/A, VXE7, VXE7/A VXG, VXQ4, VXQ4/A, VXTB, VXT1, VXT1/A, VXU, VXU1, VXU1/A, VX26 V1, WMA4, WMT8, WXE8, W1
					(1)	(1)	-	-----	2456210 ESS/A, ES1/A, ES3/A, HX/A, LH/A, LHB5, LHE/A, LJ/A, LJG/A LT/A, LW/A, LWD1/A, LX/A, LXE/A, L1/A, PX/A, QAB3/A, QD/A QH/A, QHB5, QHP1/A, QHZ/A, QMH/A, QP/A, QSE/A, QT/A, QX/A QXE/A, QXE9, QXK, Q1/A, RD/A, RSS/A, RX/A, R1/A, SD/A, SH/A SJ/A, SJG/A, SN/A, SX/A, SXE/A, S1/A, VKK, VMT/A, VPK, VS3, VS4 VX/A, VXE8, VXK, VXU/A, WMT8/A, WXE8/A, W1/A
					-	-	(1)		

NOTE A:PART NO. CHANGE D:NEWLY PROVIDED E:PART NO.DELETION K:REQUIRED NO. CORRECTION L:APPLICATION SERIAL NO. CORRECTION
 T:APPLICATION CORRECTION Z:REMARKS CHANGE

PARTS CATALOGUE NEWS

BOOKNo. : 13ZH90E9

Block No.	Ref. No.	Note	Part No.	Description	Reqd. QTY			Serial No.	Parts catalogue code
					(1)	(2)	(3)		
		L	13011-ZE8-602	RING SET, PISTON (0.25) (TEIKOKU)	(1)	(1)	-	-----	ESS, ES1, ES3, HA, HAQ, HA2, HA2/A, HEA, HEA2, HEA2/A, HEA8 HEA8/A, HH, HX, HXQ4, HXQ4/A, HX26, HX26/A, HX8, HX8/A, LH LHB1, LHB3, LHE, LHQ4, LJ, LJC, LJC/A, LJG, LSS, LT, LTJ, LW, LWD LWD1, LX, LXE, LXE8, LXE8/A, LXQ4, LXQ4/A, LXU, LXU/A, LXZ LX16, L1, PA, PAE2, PAE2/A, PA2, PA2/A, PX, PXE8, PXE8/A, PXU PXU/A, PX26, PX26/A, QA, QAB1, QAB3, QAE, QAE2, QAE2/A, QAE6 QAE6/A, QAG, QAG/A, QAG2, QAG2/A, QAQ, QAQ4, QAQ4/A, QAR2 QAR2/A, QAW, QAW/A, QA2, QA2/A, QD, QE, QE/A, QH, QHC, QHE, QHE4 QHE4/A, QHP1, QHQ4, QHQ4/A, QHR, QHR/A, QHR4, QHR4/A, QHZ QH26, QH26/A, QKE3, QKE3/A, QKE4, QL2, QME2, QME2/A, QMH, QP QSC, QSC9, QSC9/A, QSE, QSE2, QSE8, QSE8/A, QT, QWA2, QWA4 QWA4/A, QWH2, QWH2/A, QX, QXB, QXB/A, QXB6, QXB6/A, QXB7 QXB7/A, QXC, QXC4, QXC4/A, QXC6, QXC6/A, QXC9, QXC9/A, QXE QXEB, QXE4, QXE4/A, QXE6, QXE6/A, QXE8, QXE8/A, QXQ4, QXQ4/A QXU, QXU/A, QX26, QX26/A, Q1, Q2, RA, RA2, RA2/A, RD, RH, RHE RHE4, RHE4/A, RHQ4, RHQ4/A, RH26, RH26/A, RSC2, RSC2/A, RSS RX, RXQ4, RXQ4/A, RXU, RXU/A, R1, SD, SE, SE/A, SH, SHE, SHEZ SHQ4, SHQ4/A, SJ, SJG, SJP, SK, SKE1, SMC4, SMC4/A, SMD, SME1 SME1/A, SME6, SME6/A, SMX2, SN, SW, SWA4, SWC4, SWC4/A, SWE, SX SXB, SXB/A, SXB7, SXB7/A, SXE, SXEB, SXEB/A, SXE4, SXE4/A SXE8, SXE8/A, SXQ4, SXQ4/A, SXU, SXU/A, SX2, S1, VA, VAG2 VAG2/A, VAW, VAW1, VA2, VA2/A, VDE, VDE2, VDE2/A, VD16, VEB6 VH, VKB2, VKB2/A, VKE4, VKX4, VMA4, VME2, VME2/A, VME4, VMS2 VMT, VMX2, VM2, VM2/A, VNG1, VNG1/A, VNT2, VNT2/A, VN17 VN17/A, VPE4, VPE4/A, VPE5, VPE7, VPE7/A, VPX4, VPX4/A, VPX5 VPX7, VPX7/A, VSD, VSD/A, VSD3, VSD3/A, VSD7, VSD7/A, VSH7 VS37, VS37/A, VWA, VWA2, VWA2/A, VWN2, VWN2/A, VWT4, VWT4/A VW12, VW12/A, VW22, VX, VXB, VXB/A, VXB2, VXB6, VXB7, VXB7/A VXE, VXE8, VXE8/A, VXE4, VXE4/A, VXE6, VXE6/A, VXE7, VXE7/A VXG, VXQ4, VXQ4/A, VXTB, VXT1, VXT1/A, VXU, VXU1, VXU1/A, VX26 V1, WMA4, WMT8, WXE8, W1
					(1)	(1)	-	-----	2456210 ESS/A, ES1/A, ES3/A, HX/A, LH/A, LHB5, LHE/A, LJ/A, LJG/A LT/A, LW/A, LWD1/A, LX/A, LXE/A, L1/A, PX/A, QAB3/A, QD/A QH/A, QHB5, QHP1/A, QHZ/A, QMH/A, QP/A, QSE/A, QT/A, QX/A QXE/A, QXE9, QXK, Q1/A, RD/A, RSS/A, RX/A, R1/A, SD/A, SH/A SJ/A, SJG/A, SN/A, SX/A, SXE/A, S1/A, VKK, VMT/A, VPK, VS3, VS4 VX/A, VXE8, VXK, VXU/A, WMT8/A, WXE8/A, W1/A
					-	-	(1)		

NOTE A:PART NO. CHANGE D:NEWLY PROVIDED E:PART NO.DELETION K:REQUIRED NO. CORRECTION L:APPLICATION SERIAL NO. CORRECTION
 T:APPLICATION CORRECTION Z:REMARKS CHANGE

PARTS CATALOGUE NEWS

BOOKNo. : 13ZH90E9

Block No.	Ref. No.	Note	Part No.	Description	Reqd. QTY			Serial No.	Parts catalogue code
					(1)	(2)	(3)		
		L	13012-ZE8-601	RING SET, PISTON (0.50) (NIPPON)	(1)	(1)	-	-----	ESS, ES1, ES3, HA, HAQ, HA2, HA2/A, HEA, HEA2, HEA2/A, HEA8 HEA8/A, HH, HX, HXQ4, HXQ4/A, HX26, HX26/A, HX8, HX8/A, LH LHB1, LHB3, LHE, LHQ4, LJ, LJC, LJC/A, LJG, LSS, LT, LTJ, LW, LWD LWD1, LX, LXE, LXE8, LXE8/A, LXQ4, LXQ4/A, LXU, LXU/A, LXZ LX16, L1, PA, PAE2, PAE2/A, PA2, PA2/A, PX, PXE8, PXE8/A, PXU PXU/A, PX26, PX26/A, QA, QAB1, QAB3, QAE, QAE2, QAE2/A, QAE6 QAE6/A, QAG, QAG/A, QAG2, QAG2/A, QAQ, QAQ4, QAQ4/A, QAR2 QAR2/A, QAW, QAW/A, QA2, QA2/A, QD, QE, QE/A, QH, QHC, QHE, QHE4 QHE4/A, QHP1, QHQ4, QHQ4/A, QHR, QHR/A, QHR4, QHR4/A, QHZ QH26, QH26/A, QKE3, QKE3/A, QKE4, QL2, QME2, QME2/A, QMH, QP QSC, QSC9, QSC9/A, QSE, QSE2, QSE8, QSE8/A, QT, QWA2, QWA4 QWA4/A, QWH2, QWH2/A, QX, QXB, QXB/A, QXB6, QXB6/A, QXB7 QXB7/A, QXC, QXC4, QXC4/A, QXC6, QXC6/A, QXC9, QXC9/A, QXE QXEB, QXE4, QXE4/A, QXE6, QXE6/A, QXE8, QXE8/A, QXQ4, QXQ4/A QXU, QXU/A, QX26, QX26/A, Q1, Q2, RA, RA2, RA2/A, RD, RH, RHE RHE4, RHE4/A, RHQ4, RHQ4/A, RH26, RH26/A, RSC2, RSC2/A, RSS RX, RXQ4, RXQ4/A, RXU, RXU/A, R1, SD, SE, SE/A, SH, SHE, SHEZ SHQ4, SHQ4/A, SJ, SJG, SJP, SK, SKE1, SMC4, SMC4/A, SMD, SME1 SME1/A, SME6, SME6/A, SMX2, SN, SW, SWA4, SWC4, SWC4/A, SWE, SX SXB, SXB/A, SXB7, SXB7/A, SXE, SXEB, SXEB/A, SXE4, SXE4/A SXE8, SXE8/A, SXQ4, SXQ4/A, SXU, SXU/A, SX2, S1, VA, VAG2 VAG2/A, VAW, VAW1, VA2, VA2/A, VDE, VDE2, VDE2/A, VD16, VEB6 VH, VKB2, VKB2/A, VKE4, VKX4, VMA4, VME2, VME2/A, VME4, VMS2 VMT, VMX2, VM2, VM2/A, VNG1, VNG1/A, VNT2, VNT2/A, VN17 VN17/A, VPE4, VPE4/A, VPE5, VPE7, VPE7/A, VPX4, VPX4/A, VPX5 VPX7, VPX7/A, VSD, VSD/A, VSD3, VSD3/A, VSD7, VSD7/A, VSH7 VS37, VS37/A, VWA, VWA2, VWA2/A, VWN2, VWN2/A, VWT4, VWT4/A VW12, VW12/A, VW22, VX, VXB, VXB/A, VXB2, VXB6, VXB7, VXB7/A VXE, VXE8, VXE8/A, VXE4, VXE4/A, VXE6, VXE6/A, VXE7, VXE7/A VXG, VXQ4, VXQ4/A, VXTB, VXT1, VXT1/A, VXU, VXU1, VXU1/A, VX26 V1, WMA4, WMT8, WXE8, W1
					(1)	(1)	-	-----	2456210 ESS/A, ES1/A, ES3/A, HX/A, LH/A, LHB5, LHE/A, LJ/A, LJG/A LT/A, LW/A, LWD1/A, LX/A, LXE/A, L1/A, PX/A, QAB3/A, QD/A QH/A, QHB5, QHP1/A, QHZ/A, QMH/A, QP/A, QSE/A, QT/A, QX/A QXE/A, QXE9, QXK, Q1/A, RD/A, RSS/A, RX/A, R1/A, SD/A, SH/A SJ/A, SJG/A, SN/A, SX/A, SXE/A, S1/A, VKK, VMT/A, VPK, VS3, VS4 VX/A, VXE8, VXK, VXU/A, WMT8/A, WXE8/A, W1/A
					-	-	(1)		

NOTE A:PART NO. CHANGE D:NEWLY PROVIDED E:PART NO.DELETION K:REQUIRED NO. CORRECTION L:APPLICATION SERIAL NO. CORRECTION
 T:APPLICATION CORRECTION Z:REMARKS CHANGE

PARTS CATALOGUE NEWS

BOOKNo. : 13ZH90E9

Block No.	Ref. No.	Note	Part No.	Description	Reqd. QTY			Serial No.	Parts catalogue code
					(1)	(2)	(3)		
		L	13012-ZE8-602	RING SET, PISTON (0.50) (TEIKOKU)	(1)	(1)	-	-----	ESS, ES1, ES3, HA, HAQ, HA2, HA2/A, HEA, HEA2, HEA2/A, HEA8 HEA8/A, HH, HX, HXQ4, HXQ4/A, HX26, HX26/A, HX8, HX8/A, LH LHB1, LHB3, LHE, LHQ4, LJ, LJC, LJC/A, LJG, LSS, LT, LTJ, LW, LWD LWD1, LX, LXE, LXE8, LXE8/A, LXQ4, LXQ4/A, LXU, LXU/A, LXZ LX16, L1, PA, PAE2, PAE2/A, PA2, PA2/A, PX, PXE8, PXE8/A, PXU PXU/A, PX26, PX26/A, QA, QAB1, QAB3, QAE, QAE2, QAE2/A, QAE6 QAE6/A, QAG, QAG/A, QAG2, QAG2/A, QAQ, QAQ4, QAQ4/A, QAR2 QAR2/A, QAW, QAW/A, QA2, QA2/A, QD, QE, QE/A, QH, QHC, QHE, QHE4 QHE4/A, QHP1, QHQ4, QHQ4/A, QHR, QHR/A, QHR4, QHR4/A, QHZ QH26, QH26/A, QKE3, QKE3/A, QKE4, QL2, QME2, QME2/A, QMH, QP QSC, QSC9, QSC9/A, QSE, QSE2, QSE8, QSE8/A, QT, QWA2, QWA4 QWA4/A, QWH2, QWH2/A, QX, QXB, QXB/A, QXB6, QXB6/A, QXB7 QXB7/A, QXC, QXC4, QXC4/A, QXC6, QXC6/A, QXC9, QXC9/A, QXE QXEB, QXE4, QXE4/A, QXE6, QXE6/A, QXE8, QXE8/A, QXQ4, QXQ4/A QXU, QXU/A, QX26, QX26/A, Q1, Q2, RA, RA2, RA2/A, RD, RH, RHE RHE4, RHE4/A, RHQ4, RHQ4/A, RH26, RH26/A, RSC2, RSC2/A, RSS RX, RXQ4, RXQ4/A, RXU, RXU/A, R1, SD, SE, SE/A, SH, SHE, SHEZ SHQ4, SHQ4/A, SJ, SJG, SJP, SK, SKE1, SMC4, SMC4/A, SMD, SME1 SME1/A, SME6, SME6/A, SMX2, SN, SW, SWA4, SWC4, SWC4/A, SWE, SX SXB, SXB/A, SXB7, SXB7/A, SXE, SXEB, SXEB/A, SXE4, SXE4/A SXE8, SXE8/A, SXQ4, SXQ4/A, SXU, SXU/A, SX2, S1, VA, VAG2 VAG2/A, VAW, VAW1, VA2, VA2/A, VDE, VDE2, VDE2/A, VD16, VEB6 VH, VKB2, VKB2/A, VKE4, VKX4, VMA4, VME2, VME2/A, VME4, VMS2 VMT, VMX2, VM2, VM2/A, VNG1, VNG1/A, VNT2, VNT2/A, VN17 VN17/A, VPE4, VPE4/A, VPE5, VPE7, VPE7/A, VPX4, VPX4/A, VPX5 VPX7, VPX7/A, VSD, VSD/A, VSD3, VSD3/A, VSD7, VSD7/A, VSH7 VS37, VS37/A, VWA, VWA2, VWA2/A, VWN2, VWN2/A, VWT4, VWT4/A VW12, VW12/A, VW22, VX, VXB, VXB/A, VXB2, VXB6, VXB7, VXB7/A VXE, VXE8, VXE8/A, VXE4, VXE4/A, VXE6, VXE6/A, VXE7, VXE7/A VXG, VXQ4, VXQ4/A, VXTB, VXT1, VXT1/A, VXU, VXU1, VXU1/A, VX26 V1, WMA4, WMT8, WXE8, W1
					(1)	(1)	-	-----	2456210 ESS/A, ES1/A, ES3/A, HX/A, LH/A, LHB5, LHE/A, LJ/A, LJG/A LT/A, LW/A, LWD1/A, LX/A, LXE/A, L1/A, PX/A, QAB3/A, QD/A QH/A, QHB5, QHP1/A, QHZ/A, QMH/A, QP/A, QSE/A, QT/A, QX/A QXE/A, QXE9, QXK, Q1/A, RD/A, RSS/A, RX/A, R1/A, SD/A, SH/A SJ/A, SJG/A, SN/A, SX/A, SXE/A, S1/A, VKK, VMT/A, VPK, VS3, VS4 VX/A, VXE8, VXK, VXU/A, WMT8/A, WXE8/A, W1/A
					-	-	(1)		

NOTE A:PART NO. CHANGE D:NEWLY PROVIDED E:PART NO.DELETION K:REQUIRED NO. CORRECTION L:APPLICATION SERIAL NO. CORRECTION
 T:APPLICATION CORRECTION Z:REMARKS CHANGE

PARTS CATALOGUE NEWS

BOOKNo. : 13ZH90E9

Block No.	Ref. No.	Note	Part No.	Description	Reqd. QTY			Serial No.	Parts catalogue code
					(1)	(2)	(3)		
		L	13013-ZE8-601	RING SET, PISTON (0.75) (NIPPON)	(1)	(1)	-	-----	ESS, ES1, ES3, HA, HAQ, HA2, HA2/A, HEA, HEA2, HEA2/A, HEA8 HEA8/A, HH, HX, HXQ4, HXQ4/A, HX26, HX26/A, HX8, HX8/A, LH LHB1, LHB3, LHE, LHQ4, LJ, LJC, LJC/A, LJG, LSS, LT, LTJ, LW, LWD LWD1, LX, LXE, LXE8, LXE8/A, LXQ4, LXQ4/A, LXU, LXU/A, LXZ LX16, L1, PA, PAE2, PAE2/A, PA2, PA2/A, PX, PXE8, PXE8/A, PXU PXU/A, PX26, PX26/A, QA, QAB1, QAB3, QAE, QAE2, QAE2/A, QAE6 QAE6/A, QAG, QAG/A, QAG2, QAG2/A, QAQ, QAQ4, QAQ4/A, QAR2 QAR2/A, QAW, QAW/A, QA2, QA2/A, QD, QE, QE/A, QH, QHC, QHE, QHE4 QHE4/A, QHP1, QHQ4, QHQ4/A, QHR, QHR/A, QHR4, QHR4/A, QHZ QH26, QH26/A, QKE3, QKE3/A, QKE4, QL2, QME2, QME2/A, QMH, QP QSC, QSC9, QSC9/A, QSE, QSE2, QSE8, QSE8/A, QT, QWA2, QWA4 QWA4/A, QWH2, QWH2/A, QX, QXB, QXB/A, QXB6, QXB6/A, QXB7 QXB7/A, QXC, QXC4, QXC4/A, QXC6, QXC6/A, QXC9, QXC9/A, QXE QXEB, QXE4, QXE4/A, QXE6, QXE6/A, QXE8, QXE8/A, QXQ4, QXQ4/A QXU, QXU/A, QX26, QX26/A, Q1, Q2, RA, RA2, RA2/A, RD, RH, RHE RHE4, RHE4/A, RHQ4, RHQ4/A, RH26, RH26/A, RSC2, RSC2/A, RSS RX, RXQ4, RXQ4/A, RXU, RXU/A, R1, SD, SE, SE/A, SH, SHE, SHEZ SHQ4, SHQ4/A, SJ, SJG, SJP, SK, SKE1, SMC4, SMC4/A, SMD, SME1 SME1/A, SME6, SME6/A, SMX2, SN, SW, SWA4, SWC4, SWC4/A, SWE, SX SXB, SXB/A, SXB7, SXB7/A, SXE, SXEB, SXEB/A, SXE4, SXE4/A SXE8, SXE8/A, SXQ4, SXQ4/A, SXU, SXU/A, SX2, S1, VA, VAG2 VAG2/A, VAW, VAW1, VA2, VA2/A, VDE, VDE2, VDE2/A, VD16, VEB6 VH, VKB2, VKB2/A, VKE4, VKX4, VMA4, VME2, VME2/A, VME4, VMS2 VMT, VMX2, VM2, VM2/A, VNG1, VNG1/A, VNT2, VNT2/A, VN17 VN17/A, VPE4, VPE4/A, VPE5, VPE7, VPE7/A, VPX4, VPX4/A, VPX5 VPX7, VPX7/A, VSD, VSD/A, VSD3, VSD3/A, VSD7, VSD7/A, VSH7 VS37, VS37/A, VWA, VWA2, VWA2/A, VWN2, VWN2/A, VWT4, VWT4/A VW12, VW12/A, VW22, VX, VXB, VXB/A, VXB2, VXB6, VXB7, VXB7/A VXE, VXE8, VXE8/A, VXE4, VXE4/A, VXE6, VXE6/A, VXE7, VXE7/A VXG, VXQ4, VXQ4/A, VXTB, VXT1, VXT1/A, VXU, VXU1, VXU1/A, VX26 V1, WMA4, WMT8, WXE8, W1
					(1)	(1)	-	-----	2456210 ESS/A, ES1/A, ES3/A, HX/A, LH/A, LHB5, LHE/A, LJ/A, LJG/A LT/A, LW/A, LWD1/A, LX/A, LXE/A, L1/A, PX/A, QAB3/A, QD/A QH/A, QHB5, QHP1/A, QHZ/A, QMH/A, QP/A, QSE/A, QT/A, QX/A QXE/A, QXE9, QXK, Q1/A, RD/A, RSS/A, RX/A, R1/A, SD/A, SH/A SJ/A, SJG/A, SN/A, SX/A, SXE/A, S1/A, VKK, VMT/A, VPK, VS3, VS4 VX/A, VXE8, VXK, VXU/A, WMT8/A, WXE8/A, W1/A
					-	-	(1)		

NOTE A:PART NO. CHANGE D:NEWLY PROVIDED E:PART NO.DELETION K:REQUIRED NO. CORRECTION L:APPLICATION SERIAL NO. CORRECTION
 T:APPLICATION CORRECTION Z:REMARKS CHANGE

PARTS CATALOGUE NEWS

BOOKNo. : 13ZH90E9

Block No.	Ref. No.	Note	Part No.	Description	Reqd. QTY			Serial No.	Parts catalogue code
					(1)	(2)	(3)		
		L	13013-ZE8-602	RING SET, PISTON (0.75) (TEIKOKU)	(1)	(1)	-	-----	ESS, ES1, ES3, HA, HAQ, HA2, HA2/A, HEA, HEA2, HEA2/A, HEA8 HEA8/A, HH, HX, HXQ4, HXQ4/A, HX26, HX26/A, HX8, HX8/A, LH LHB1, LHB3, LHE, LHQ4, LJ, LJC, LJC/A, LJG, LSS, LT, LTJ, LW, LWD LWD1, LX, LXE, LXE8, LXE8/A, LXQ4, LXQ4/A, LXU, LXU/A, LXZ LX16, L1, PA, PAE2, PAE2/A, PA2, PA2/A, PX, PXE8, PXE8/A, PXU PXU/A, PX26, PX26/A, QA, QAB1, QAB3, QAE, QAE2, QAE2/A, QAE6 QAE6/A, QAG, QAG/A, QAG2, QAG2/A, QAQ, QAQ4, QAQ4/A, QAR2 QAR2/A, QAW, QAW/A, QA2, QA2/A, QD, QE, QE/A, QH, QHC, QHE, QHE4 QHE4/A, QHP1, QHQ4, QHQ4/A, QHR, QHR/A, QHR4, QHR4/A, QHZ QH26, QH26/A, QKE3, QKE3/A, QKE4, QL2, QME2, QME2/A, QMH, QP QSC, QSC9, QSC9/A, QSE, QSE2, QSE8, QSE8/A, QT, QWA2, QWA4 QWA4/A, QWH2, QWH2/A, QX, QXB, QXB/A, QXB6, QXB6/A, QXB7 QXB7/A, QXC, QXC4, QXC4/A, QXC6, QXC6/A, QXC9, QXC9/A, QXE QXEB, QXE4, QXE4/A, QXE6, QXE6/A, QXE8, QXE8/A, QXQ4, QXQ4/A QXU, QXU/A, QX26, QX26/A, Q1, Q2, RA, RA2, RA2/A, RD, RH, RHE RHE4, RHE4/A, RHQ4, RHQ4/A, RH26, RH26/A, RSC2, RSC2/A, RSS RX, RXQ4, RXQ4/A, RXU, RXU/A, R1, SD, SE, SE/A, SH, SHE, SHEZ SHQ4, SHQ4/A, SJ, SJG, SJP, SK, SKE1, SMC4, SMC4/A, SMD, SME1 SME1/A, SME6, SME6/A, SMX2, SN, SW, SWA4, SWC4, SWC4/A, SWE, SX SXB, SXB/A, SXB7, SXB7/A, SXE, SXEB, SXEB/A, SXE4, SXE4/A SXE8, SXE8/A, SXQ4, SXQ4/A, SXU, SXU/A, SX2, S1, VA, VAG2 VAG2/A, VAW, VAW1, VA2, VA2/A, VDE, VDE2, VDE2/A, VD16, VEB6 VH, VKB2, VKB2/A, VKE4, VKX4, VMA4, VME2, VME2/A, VME4, VMS2 VMT, VMX2, VM2, VM2/A, VNG1, VNG1/A, VNT2, VNT2/A, VN17 VN17/A, VPE4, VPE4/A, VPE5, VPE7, VPE7/A, VPX4, VPX4/A, VPX5 VPX7, VPX7/A, VSD, VSD/A, VSD3, VSD3/A, VSD7, VSD7/A, VSH7 VS37, VS37/A, VWA, VWA2, VWA2/A, VWN2, VWN2/A, VWT4, VWT4/A VW12, VW12/A, VW22, VX, VXB, VXB/A, VXB2, VXB6, VXB7, VXB7/A VXE, VXE8, VXE8/A, VXE4, VXE4/A, VXE6, VXE6/A, VXE7, VXE7/A VXG, VXQ4, VXQ4/A, VXTB, VXT1, VXT1/A, VXU, VXU1, VXU1/A, VX26 V1, WMA4, WMT8, WXE8, W1
					(1)	(1)	-	-----	2456210 ESS/A, ES1/A, ES3/A, HX/A, LH/A, LHB5, LHE/A, LJ/A, LJG/A LT/A, LW/A, LWD1/A, LX/A, LXE/A, L1/A, PX/A, QAB3/A, QD/A QH/A, QHB5, QHP1/A, QHZ/A, QMH/A, QP/A, QSE/A, QT/A, QX/A QXE/A, QXE9, QXK, Q1/A, RD/A, RSS/A, RX/A, R1/A, SD/A, SH/A SJ/A, SJG/A, SN/A, SX/A, SXE/A, S1/A, VKK, VMT/A, VPK, VS3, VS4 VX/A, VXE8, VXK, VXU/A, WMT8/A, WXE8/A, W1/A
					-	-	(1)		

NOTE A:PART NO. CHANGE D:NEWLY PROVIDED E:PART NO.DELETION K:REQUIRED NO. CORRECTION L:APPLICATION SERIAL NO. CORRECTION
 T:APPLICATION CORRECTION Z:REMARKS CHANGE

PARTS CATALOGUE NEWS

BOOKNo. : 13ZH90E9

Block No.	Ref. No.	Note	Part No.	Description	Reqd. QTY			Serial No.	Parts catalogue code
					(1)	(2)	(3)		
		T	13010-Z5H-004	RING SET, PISTON (STD.) (TEIKOKU)	1	1	-	2456211	----- ESS/A, ES1/A, ES3/A, HX/A, LH/A, LHB5, LHE/A, LJ/A, LJG/A LT/A, LW/A, LWD1/A, LX/A, LXE/A, L1/A, PX/A, QAB3/A, QD/A QH/A, QHB5, QHP1/A, QHZ/A, QMH/A, QP/A, QSE/A, QT/A, QX/A QXE/A, QXE9, QXK, Q1/A, RD/A, RSS/A, RX/A, R1/A, SD/A, SH/A SJ/A, SJG/A, SN/A, SX/A, SXE/A, S1/A, VKK, VMT/A, VPK, VS3, VS4 VX/A, VXE8, VXX, VXU/A, WMT8/A, WXE8/A, W1/A
					1	-	-	-----	----- ES4, RA3, VS5
		T	13011-Z5H-004	RING SET, PISTON (0.25) (TEIKOKU)	(1)	(1)	-	2456211	----- ESS/A, ES1/A, ES3/A, HX/A, LH/A, LHB5, LHE/A, LJ/A, LJG/A LT/A, LW/A, LWD1/A, LX/A, LXE/A, L1/A, PX/A, QAB3/A, QD/A QH/A, QHB5, QHP1/A, QHZ/A, QMH/A, QP/A, QSE/A, QT/A, QX/A QXE/A, QXE9, QXK, Q1/A, RD/A, RSS/A, RX/A, R1/A, SD/A, SH/A SJ/A, SJG/A, SN/A, SX/A, SXE/A, S1/A, VKK, VMT/A, VPK, VS3, VS4 VX/A, VXE8, VXX, VXU/A, WMT8/A, WXE8/A, W1/A
					(1)	-	-	-----	----- ES4, RA3, VS5
		T	13012-Z5H-004	RING SET, PISTON (0.50) (TEIKOKU)	(1)	(1)	-	2456211	----- ESS/A, ES1/A, ES3/A, HX/A, LH/A, LHB5, LHE/A, LJ/A, LJG/A LT/A, LW/A, LWD1/A, LX/A, LXE/A, L1/A, PX/A, QAB3/A, QD/A QH/A, QHB5, QHP1/A, QHZ/A, QMH/A, QP/A, QSE/A, QT/A, QX/A QXE/A, QXE9, QXK, Q1/A, RD/A, RSS/A, RX/A, R1/A, SD/A, SH/A SJ/A, SJG/A, SN/A, SX/A, SXE/A, S1/A, VKK, VMT/A, VPK, VS3, VS4 VX/A, VXE8, VXX, VXU/A, WMT8/A, WXE8/A, W1/A
					(1)	-	-	-----	----- ES4, RA3, VS5
		T	13013-Z5H-004	RING SET, PISTON (0.75) (TEIKOKU)	(1)	(1)	-	2456211	----- ESS/A, ES1/A, ES3/A, HX/A, LH/A, LHB5, LHE/A, LJ/A, LJG/A LT/A, LW/A, LWD1/A, LX/A, LXE/A, L1/A, PX/A, QAB3/A, QD/A QH/A, QHB5, QHP1/A, QHZ/A, QMH/A, QP/A, QSE/A, QT/A, QX/A QXE/A, QXE9, QXK, Q1/A, RD/A, RSS/A, RX/A, R1/A, SD/A, SH/A SJ/A, SJG/A, SN/A, SX/A, SXE/A, S1/A, VKK, VMT/A, VPK, VS3, VS4 VX/A, VXE8, VXX, VXU/A, WMT8/A, WXE8/A, W1/A
					(1)	-	-	-----	----- ES4, RA3, VS5

NOTE A:PART NO. CHANGE D:NEWLY PROVIDED E:PART NO.DELETION K:REQUIRED NO. CORRECTION L:APPLICATION SERIAL NO. CORRECTION
T:APPLICATION CORRECTION Z:REMARKS CHANGE

PARTS CATALOGUE NEWS

BOOKNo. : 13ZH90E9

Block No.	Ref. No.	Note	Part No.	Description	Reqd. QTY			Serial No.	Parts catalogue code
					(1)	(2)	(3)		
	2	L	13101-ZH9-000	PISTON (STD.)	1	1	-	-----	ESS, ES1, ES3, HA, HAQ, HA2, HA2/A, HEA, HEA2, HEA2/A, HEA8 HEA8/A, HH, HX, HXQ4, HXQ4/A, HX26, HX26/A, HX8, HX8/A, LH LHB1, LHB3, LHE, LHQ4, LJ, LJC, LJC/A, LJJ, LSS, LT, LTJ, LW, LWD LWD1, LX, LXE, LXE8, LXE8/A, LXQ4, LXQ4/A, LXU, LXU/A, LXZ LX16, L1, PA, PAE2, PAE2/A, PA2, PA2/A, PX, PXE8, PXE8/A, PXU PXU/A, PX26, PX26/A, QA, QAB1, QAB3, QAE, QAE2, QAE2/A, QAE6 QAE6/A, QAG, QAG/A, QAG2, QAG2/A, QAQ, QAQ4, QAQ4/A, QAR2 QAR2/A, QAW, QAW/A, QA2, QA2/A, QD, QE, QE/A, QH, QHC, QHE, QHE4 QHE4/A, QHP1, QHQ4, QHQ4/A, QHR, QHR/A, QHR4, QHR4/A, QHZ QH26, QH26/A, QKE3, QKE3/A, QKE4, QL2, QME2, QME2/A, QMH, QP QSC, QSC9, QSC9/A, QSE, QSE2, QSE8, QSE8/A, QWA2, QWA4, QWA4/A QWH2, QWH2/A, QX, QXB, QXB/A, QXB6, QXB6/A, QXB7, QXB7/A, QXC QXC4, QXC4/A, QXC6, QXC6/A, QXC9, QXC9/A, QXE, QXEB, QXE4 QXE4/A, QXE6, QXE6/A, QXE8, QXE8/A, QXQ4, QXQ4/A, QXU, QXU/A QX26, QX26/A, Q1, Q2, RA, RA2, RA2/A, RD, RH, RHE, RHE4, RHE4/A RHQ4, RHQ4/A, RH26, RH26/A, RSC2, RSC2/A, RSS, RX, RXQ4 RXQ4/A, RXU, RXU/A, R1, SD, SE, SE/A, SH, SHE, SHEZ, SHQ4 SHQ4/A, SJ, SJG, SJP, SK, SKE1, SMC4, SMC4/A, SMD, SME1, SME1/A SME6, SME6/A, SMX2, SW, SWA4, SWC4, SWC4/A, SWE, SX, SXB, SXB/A SXB7, SXB7/A, SXE, SXEB, SXEB/A, SXE4, SXE4/A, SXE8, SXE8/A SXQ4, SXQ4/A, SXU, SXU/A, SX2, S1, VA, VAG2, VAG2/A, VAW, VAW1 VA2, VA2/A, VDE, VDE2, VDE2/A, VD16, VEB6, VH, VKB2, VKB2/A VKE4, VKX4, VMA4, VME2, VME2/A, VME4, VMS2, VMT, VMX2, VM2 VM2/A, VNG1, VNG1/A, VNT2, VNT2/A, VN17, VN17/A, VPE4, VPE4/A VPE5, VPE7, VPE7/A, VPX4, VPX4/A, VPX5, VPX7, VPX7/A, VSD VSD/A, VSD3, VSD3/A, VSD7, VSD7/A, VSH7, VS37, VS37/A, VWA VWA2, VWA2/A, VWN2, VWN2/A, VWT4, VWT4/A, VW12, VW12/A, VW22 VX, VXB, VXB/A, VXB2, VXB6, VXB7, VXB7/A, VXE, VXEB, VXEB/A VXE4, VXE4/A, VXE6, VXE6/A, VXE7, VXE7/A, VXG, VXQ4, VXQ4/A VXTB, VXT1, VXT1/A, VXU, VXU1, VXU1/A, VX26, V1, WMA4, WMT8 WXE8, W1
					1	1	-	----- 2456210	ESS/A, ES1/A, ES3/A, HX/A, LH/A, LHB5, LHE/A, LJ/A, LJJ/A LT/A, LW/A, LWD1/A, LX/A, LXE/A, L1/A, PX/A, QAB3/A, QD/A QH/A, QHB5, QHP1/A, QHZ/A, QMH/A, QP/A, QSE/A, QX/A, QXE/A QXE9, QXK, Q1/A, RD/A, RSS/A, RX/A, R1/A, SD/A, SH/A, SJ/A SJG/A, SX/A, SXE/A, S1/A, VKK, VMT/A, VPK, VS3, VS4, VX/A, VXE8 VXK, VXU/A, WMT8/A, WXE8/A, W1/A
					-	-	1		

NOTE A:PART NO. CHANGE D:NEWLY PROVIDED E:PART NO.DELETION K:REQUIRED NO. CORRECTION L:APPLICATION SERIAL NO. CORRECTION
T:APPLICATION CORRECTION Z:REMARKS CHANGE

PARTS CATALOGUE NEWS

BOOKNo. : 13ZH90E9

Block No.	Ref. No.	Note	Part No.	Description	Reqd. QTY			Serial No.	Parts catalogue code
					(1)	(2)	(3)		
		L	13102-ZH9-000	PISTON (0.25)	(1)	(1)	-		GX270 ESS, ES1, ES3, HA, HAQ, HA2, HA2/A, HEA, HEA2, HEA2/A, HEA8 HEA8/A, HH, HX, HXQ4, HXQ4/A, HX26, HX26/A, HX8, HX8/A, LH LHB1, LHB3, LHE, LHQ4, LJ, LJC, LJC/A, LJC, LSS, LT, LTJ, LW, LWD LWD1, LX, LXE, LXE8, LXE8/A, LXQ4, LXQ4/A, LXU, LXU/A, LXZ LX16, L1, PA, PAE2, PAE2/A, PA2, PA2/A, PX, PXE8, PXE8/A, PXU PXU/A, PX26, PX26/A, QA, QAB1, QAB3, QAE, QAE2, QAE2/A, QAE6 QAE6/A, QAG, QAG/A, QAG2, QAG2/A, QAQ, QAQ4, QAQ4/A, QAR2 QAR2/A, QAW, QAW/A, QA2, QA2/A, QD, QE, QE/A, QH, QHC, QHE, QHE4 QHE4/A, QHP1, QHQ4, QHQ4/A, QHR, QHR/A, QHR4, QHR4/A, QHZ QH26, QH26/A, QKE3, QKE3/A, QKE4, QL2, QME2, QME2/A, QMH, QP QSC, QSC9, QSC9/A, QSE, QSE2, QSE8, QSE8/A, QT, QWA2, QWA4 QWA4/A, QWH2, QWH2/A, QX, QXB, QXB/A, QXB6, QXB6/A, QXB7 QXB7/A, QXC, QXC4, QXC4/A, QXC6, QXC6/A, QXC9, QXC9/A, QXE QXE8, QXE8/A, SXQ4, SXQ4/A, SXU, SXU/A, SX2, S1, VA, VAG2 VAG2/A, VAW, VAW1, VA2, VA2/A, VDE, VDE2, VDE2/A, VD16, VEB6 VH, VKB2, VKB2/A, VKE4, VKX4, VMA4, VME2, VME2/A, VME4, VMS2 VMT, VMX2, VM2, VM2/A, VNG1, VNG1/A, VNT2, VNT2/A, VN17 VN17/A, VPE4, VPE4/A, VPE5, VPE7, VPE7/A, VPX4, VPX4/A, VPX5 VPX7, VPX7/A, VSD, VSD/A, VSD3, VSD3/A, VSD7, VSD7/A, VSH7 VS37, VS37/A, VWA, VWA2, VWA2/A, VWN2, VWN2/A, VWT4, VWT4/A VW12, VW12/A, VW22, VX, VXB, VXB/A, VXB2, VXB6, VXB7, VXB7/A VXE, VXEB, VXEB/A, VXE4, VXE4/A, VXE6, VXE6/A, VXE7, VXE7/A VXG, VXQ4, VXQ4/A, VXTB, VXT1, VXT1/A, VXU, VXU1, VXU1/A, VX26 V1, WMA4, WMT8, WXE8, W1 (1) (1) - ----- 2456210 ESS/A, ES1/A, ES3/A, HX/A, LH/A, LHB5, LHE/A, LJ/A, LJC/A LT/A, LW/A, LWD1/A, LX/A, LXE/A, L1/A, PX/A, QAB3/A, QD/A QH/A, QHB5, QHP1/A, QHZ/A, QMH/A, QP/A, QSE/A, QT/A, QX/A QXE/A, QXE9, QXK, Q1/A, RD/A, RSS/A, RX/A, R1/A, SD/A, SH/A SJ/A, SJG/A, SN/A, SX/A, SXE/A, S1/A, VKK, VMT/A, VPK, VS3, VS4 VX/A, VXE8, VXX, VXU/A, WMT8/A, WXE8/A, W1/A - - (1)

NOTE A:PART NO. CHANGE D:NEWLY PROVIDED E:PART NO.DELETION K:REQUIRED NO. CORRECTION L:APPLICATION SERIAL NO. CORRECTION
 T:APPLICATION CORRECTION Z:REMARKS CHANGE

PARTS CATALOGUE NEWS

BOOKNo. : 13ZH90E9

Block No.	Ref. No.	Note	Part No.	Description	Reqd. QTY			Serial No.	Parts catalogue code
					(1)	(2)	(3)		
		L	13103-ZH9-000	PISTON (0.50)	(1)	(1)	-		GX270 ESS, ES1, ES3, HA, HAQ, HA2, HA2/A, HEA, HEA2, HEA2/A, HEA8 HEA8/A, HH, HX, HXQ4, HXQ4/A, HX26, HX26/A, HX8, HX8/A, LH LHB1, LHB3, LHE, LHQ4, LJ, LJC, LJC/A, LJC, LSS, LT, LTJ, LW, LWD LWD1, LX, LXE, LXE8, LXE8/A, LXQ4, LXQ4/A, LXU, LXU/A, LXZ LX16, L1, PA, PAE2, PAE2/A, PA2, PA2/A, PX, PXE8, PXE8/A, PXU PXU/A, PX26, PX26/A, QA, QAB1, QAB3, QAE, QAE2, QAE2/A, QAE6 QAE6/A, QAG, QAG/A, QAG2, QAG2/A, QAQ, QAQ4, QAQ4/A, QAR2 QAR2/A, QAW, QAW/A, QA2, QA2/A, QD, QE, QE/A, QH, QHC, QHE, QHE4 QHE4/A, QHP1, QHQ4, QHQ4/A, QHR, QHR/A, QHR4, QHR4/A, QHZ QH26, QH26/A, QKE3, QKE3/A, QKE4, QL2, QME2, QME2/A, QMH, QP QSC, QSC9, QSC9/A, QSE, QSE2, QSE8, QSE8/A, QT, QWA2, QWA4 QWA4/A, QWH2, QWH2/A, QX, QXB, QXB/A, QXB6, QXB6/A, QXB7 QXB7/A, QXC, QXC4, QXC4/A, QXC6, QXC6/A, QXC9, QXC9/A, QXE QXE8, QXE8/A, QXE4, QXE4/A, QXE6, QXE6/A, QXE8, QXE8/A, QXQ4, QXQ4/A QXU, QXU/A, QX26, QX26/A, Q1, Q2, RA, RA2, RA2/A, RD, RH, RHE RHE4, RHE4/A, RHQ4, RHQ4/A, RH26, RH26/A, RSC2, RSC2/A, RSS RX, RXQ4, RXQ4/A, RXU, RXU/A, R1, SD, SE, SE/A, SH, SHE, SHE SHQ4, SHQ4/A, SJ, SJG, SJP, SK, SKE1, SMC4, SMC4/A, SMD, SME1 SME1/A, SME6, SME6/A, SMX2, SN, SW, SWA4, SWC4, SWC4/A, SWE, SX SXB, SXB/A, SXB7, SXB7/A, SXE, SXEB, SXEB/A, SXE4, SXE4/A SXE8, SXE8/A, SXQ4, SXQ4/A, SXU, SXU/A, SX2, S1, VA, VAG2 VAG2/A, VAW, VAW1, VA2, VA2/A, VDE, VDE2, VDE2/A, VD16, VEB6 VH, VKB2, VKB2/A, VKE4, VKX4, VMA4, VME2, VME2/A, VME4, VMS2 VMT, VMX2, VM2, VM2/A, VNG1, VNG1/A, VNT2, VNT2/A, VN17 VN17/A, VPE4, VPE4/A, VPE5, VPE7, VPE7/A, VPX4, VPX4/A, VPX5 VPX7, VPX7/A, VSD, VSD/A, VSD3, VSD3/A, VSD7, VSD7/A, VSH7 VS37, VS37/A, VWA, VWA2, VWA2/A, VWN2, VWN2/A, VWT4, VWT4/A VW12, VW12/A, VW22, VX, VXB, VXB/A, VXB2, VXB6, VXB7, VXB7/A VXE, VXEB, VXEB/A, VXE4, VXE4/A, VXE6, VXE6/A, VXE7, VXE7/A VXG, VXQ4, VXQ4/A, VXTB, VXT1, VXT1/A, VXU, VXU1, VXU1/A, VX26 V1, WMA4, WMT8, WXE8, W1 (1) (1) - ----- 2456210 ESS/A, ES1/A, ES3/A, HX/A, LH/A, LHB5, LHE/A, LJ/A, LJG/A LT/A, LW/A, LWD1/A, LX/A, LXE/A, L1/A, PX/A, QAB3/A, QD/A QH/A, QHB5, QHP1/A, QHZ/A, QMH/A, QP/A, QSE/A, QT/A, QX/A QXE/A, QXE9, QXK, Q1/A, RD/A, RSS/A, RX/A, R1/A, SD/A, SH/A SJ/A, SJG/A, SN/A, SX/A, SXE/A, S1/A, VKK, VMT/A, VPK, VS3, VS4 VX/A, VXE8, VXX, VXU/A, WMT8/A, WXE8/A, W1/A - - (1)

NOTE A:PART NO. CHANGE D:NEWLY PROVIDED E:PART NO.DELETION K:REQUIRED NO. CORRECTION L:APPLICATION SERIAL NO. CORRECTION
 T:APPLICATION CORRECTION Z:REMARKS CHANGE

PARTS CATALOGUE NEWS

BOOKNo. : 13ZH90E9

Block No.	Ref. No.	Note	Part No.	Description	Reqd. QTY			Serial No.	Parts catalogue code
					(1)	(2)	(3)		
		L	13104-ZH9-000	PISTON (0.75)	(1)	(1)	-	-----	ESS, ES1, ES3, HA, HAQ, HA2, HA2/A, HEA, HEA2, HEA2/A, HEA8 HEA8/A, HH, HX, HXQ4, HXQ4/A, HX26, HX26/A, HX8, HX8/A, LH LHB1, LHB3, LHE, LHQ4, LJ, LJC, LJC/A, LJJ, LSS, LT, LTJ, LW, LWD LWD1, LX, LXE, LXE8, LXE8/A, LXQ4, LXQ4/A, LXU, LXU/A, LXZ LX16, L1, PA, PAE2, PAE2/A, PA2, PA2/A, PX, PXE8, PXE8/A, PXU PXU/A, PX26, PX26/A, QA, QAB1, QAB3, QAE, QAE2, QAE2/A, QAE6 QAE6/A, QAG, QAG/A, QAG2, QAG2/A, QAQ, QAQ4, QAQ4/A, QAR2 QAR2/A, QAW, QAW/A, QA2, QA2/A, QD, QE, QE/A, QH, QHC, QHE, QHE4 QHE4/A, QHP1, QHQ4, QHQ4/A, QHR, QHR/A, QHR4, QHR4/A, QHZ QH26, QH26/A, QKE3, QKE3/A, QKE4, QL2, QME2, QME2/A, QMH, QP QSC, QSC9, QSC9/A, QSE, QSE2, QSE8, QSE8/A, QT, QWA2, QWA4 QWA4/A, QWH2, QWH2/A, QX, QXB, QXB/A, QXB6, QXB6/A, QXB7 QXB7/A, QXC, QXC4, QXC4/A, QXC6, QXC6/A, QXC9, QXC9/A, QXE QXE8, QXE8/A, SXQ4, SXQ4/A, SXU, SXU/A, SX2, S1, VA, VAG2 VAG2/A, VAW, VAW1, VA2, VA2/A, VDE, VDE2, VDE2/A, VD16, VEB6 VH, VKB2, VKB2/A, VKE4, VKX4, VMA4, VME2, VME2/A, VME4, VMS2 VMT, VMX2, VM2, VM2/A, VNG1, VNG1/A, VNT2, VNT2/A, VN17 VN17/A, VPE4, VPE4/A, VPE5, VPE7, VPE7/A, VPX4, VPX4/A, VPX5 VPX7, VPX7/A, VSD, VSD/A, VSD3, VSD3/A, VSD7, VSD7/A, VSH7 VS37, VS37/A, VWA, VWA2, VWA2/A, VWN2, VWN2/A, VWT4, VWT4/A VW12, VW12/A, VW22, VX, VXB, VXB/A, VXB2, VXB6, VXB7, VXB7/A VXE, VXEB, VXEB/A, VXE4, VXE4/A, VXE6, VXE6/A, VXE7, VXE7/A VXG, VXQ4, VXQ4/A, VXTB, VXT1, VXT1/A, VXU, VXU1, VXU1/A, VX26 V1, WMA4, WMT8, WXE8, W1
					(1)	(1)	-	----- 2456210	ESS/A, ES1/A, ES3/A, HX/A, LH/A, LHB5, LHE/A, LJ/A, LJJ/A LT/A, LW/A, LWD1/A, LX/A, LXE/A, L1/A, PX/A, QAB3/A, QD/A QH/A, QHB5, QHP1/A, QHZ/A, QMH/A, QP/A, QSE/A, QT/A, QX/A QXE/A, QXE9, QXK, Q1/A, RD/A, RSS/A, RX/A, R1/A, SD/A, SH/A SJ/A, SJG/A, SN/A, SX/A, SXE/A, S1/A, VKK, VMT/A, VPK, VS3, VS4 VX/A, VXE8, VXE8/A, WMT8/A, WXE8/A, W1/A
					-	-	(1)		
		T	13101-ZH9-010	PISTON (STD.)	1	1	-	2456211 -----	ESS/A, ES1/A, ES3/A, HX/A, LH/A, LHB5, LHE/A, LJ/A, LJJ/A LT/A, LW/A, LWD1/A, LX/A, LXE/A, L1/A, PX/A, QAB3/A, QD/A QH/A, QHB5, QHP1/A, QHZ/A, QMH/A, QP/A, QSE/A, QT/A, QX/A QXE/A, QXE9, QXK, Q1/A, RD/A, RSS/A, RX/A, R1/A, SD/A, SH/A SJ/A, SJG/A, SN/A, SX/A, SXE/A, S1/A, VKK, VMT/A, VPK, VS3, VS4 VX/A, VXE8, VXE8/A, WMT8/A, WXE8/A, W1/A

NOTE A:PART NO. CHANGE D:NEWLY PROVIDED E:PART NO.DELETION K:REQUIRED NO. CORRECTION L:APPLICATION SERIAL NO. CORRECTION
 T:APPLICATION CORRECTION Z:REMARKS CHANGE



PARTS CATALOGUE NEWS

Honda Motor Co., Ltd. Service Division

PARTS CATALOGUE - CORRECTED

Printed in Japan

CODE NO.	BOOKLET TYPE	13ZH90E9
	MICRO-FICHE	13ZH90EI/FI
PARTS CATALOGUE NEWS	GX270 GX270[PROPANE ENGINE]	
NEWS NO.	029	

Block No.	Ref. No.	Note	Part No.	Description	Reqd. QTY			Serial No.	Parts catalogue code						
					(1)	(2)	(3)								
E-28	17		87532-ZH8-810	MARK, OIL ALERT (ENGLISH)	1	(1)	1	-----	ES1, HAP, HAP/A, HAQ, HA2, HA2/A, HEA, HEA2, HEA2/A, HEA8, HEA8/A, HX26, HX26/A, HX8, HX8/A, LXE, LXE/A, LXE8, LXE8/A, LXU, LXU/A, LX16, PAE2, PAE2/A, PA2, PA2/A, PXE8, PXE8/A, PXU, PXU/A, PX26, PX26/A, QAB1, QAB3, QAB3/A, QAE, QAE2, QAE2/A, QAE6, QAE6/A, QAG, QAG/A, QAG2, QAG2/A, QAO, QAR2, QAR2/A, QAW, QA2, QKE4, QL2, QSC, QSC9, QSC9/A, QSE, QSE/A, QSE2, QSE8, QSE8/A, QWA2, QWA4, QWA4/A, QWH2, QWH2/A, QXB6, QXB6/A, QXC6, QXC6/A, QXC9, QXE6, QXE6/A, QXE8, QXE8/A, QXU, QXU/A, QX26, QX26/A, Q2, RA2, RA2/A, RSC2, RSC2/A, RXU, RXU/A, SMD, SMX2, SWC4/A, SXE8, SXE8/A, SXU, SXU/A, SX2, VAW1, VA2, VA2/A, VDE, VDE2, VDE2/A, VD16, VEB6, VKB2, VKB2/A, VME2, VME2/A, VM2, VM2/A, VNT2, VNT2/A, VWN2, VWN2/A, VW12, VW12/A, VW22, VXB2, VXB6, VXE6, VXE6/A, VXU, VXU1, VXU1/A, VX26, WMT8, WMT8/A, WXE8, WXE8/A, W1/A	1	(1)	-	-----	2459526	ES1/A, HX/A, LX/A, L1/A, PX/A, QX/A, QXE/A, Q1/A, RX/A, R1/A, SX/A, SXE/A, VX/A, VXU/A
					1	(1)	-	-----	1033680	-----	HA, HX, LX, LXZ, L1, PA, PX, QA, QX, QXC, QXE, QXEB, Q1, RA, RX, R1, SX, SXE, VA, VAW, VX, VXE, V1, W1				
					1	-	-	-----	1106273	-----	VSD3, VXG				
					1	-	-	-----	2373000	-----	QAW/A, QA2/A, QXC9/A				
					1	-	-	-----	1033680	1106273	QXB, SXB, SXEB, VNG1, VSD, VXB, VXEB				

NOTE A:PART NO. CHANGE D:NEWLY PROVIDED E:PART NO.DELETION K:REQUIRED NO. CORRECTION L:APPLICATION SERIAL NO. CORRECTION
T:APPLICATION CORRECTION Z:REMARKS CHANGE

PARTS CATALOGUE NEWS

BOOKNo. : 13ZH90E9

Block No.	Ref. No.	Note	Part No.	Description	Reqd. QTY			Serial No.	Parts catalogue code
					(1)	GX270 (2)	(3)		
					1	-	-	1340170 -----	SWC4
		A	87530-ZL8-850	1	(1)	-	2459527 -----	ES1/A, HX/A, LX/A, L1/A, PX/A, QX/A, QXE/A, Q1/A, RX/A, R1/A SX/A, SXE/A, S1/A, VX/A, VXU/A
E-28-1	8		87532-ZH8-000	MARK, OIL ALERT	1	1	-	-----	LJC, LJC/A, W1/A
					1	1	-	1033680 -----	L1, Q1, R1, SJP, S1, V1, W1
					-	1	-	----- 2459526	L1/A, Q1/A, R1/A, S1/A
		A	87530-ZL8-810	-	1	-	2459527 -----	L1/A, Q1/A, R1/A, S1/A

NOTE A:PART NO. CHANGE D:NEWLY PROVIDED E:PART NO. DELETION K:REQUIRED NO. CORRECTION L:APPLICATION SERIAL NO. CORRECTION
T:APPLICATION CORRECTION Z:REMARKS CHANGE



PARTS CATALOGUE NEWS

Honda Motor Co., Ltd. Service Division

PARTS CATALOGUE - CORRECTED

Printed in Japan

CODE NO.	BOOKLET TYPE	13ZH90E9
	MICRO-FICHE	13ZH90EI/FI
PARTS CATALOGUE NEWS	GX270 GX270[PROPANE ENGINE]	
NEWS NO.	030	

Block No.	Ref. No.	Note	Part No.	Description	Reqd. QTY			Serial No.	Parts catalogue code		
					(1)	(2)	(3)				
E-16-4	1		18310-ZD1-E31	MUFFLER COMP.	1	-	-	-----	ES3, VMT		
					1	-	-	-----	2464914	ES3/A, ES4, VMT/A	
			18310-ZE2-V60	MUFFLER COMP. (TSURUMI)	1	-	-	-----	VKE4, VKX4		
					1	-	-	-----	2465165	VKK, VS3, VS4, VS5	
			A	18310-ZD1-E32	MUFFLER COMP.	1	-	-	2464915	-----	ES3/A, ES4, VMT/A
			A	18310-ZE2-V61	MUFFLER COMP. (TSURUMI)	1	-	-	2465166	-----	VKK, VS3, VS4, VS5
E-17	15		91424-Z5F-801	TUBE, FUEL, 4. 5X222 (FKM)	1	-	-	-----	2466049	QXK, RA3, VXE8	
					1	-	-	-----	2466050	-----	QXK, RA3, VXE8
	20		91424-Z5J-801	TUBE, FUEL, 4. 5X120 (FKM)	1	-	-	-----	2466574	VKK, VPK	
					1	-	-	-----	2466575	-----	VKK, VPK
	21		91424-Z4J-801	TUBE, FUEL, 4. 5X150 (FKM)	1	-	-	-----	2466574	VKK, VPK	
					1	-	-	-----	2466575	-----	VKK, VPK

NOTE A:PART NO. CHANGE D:NEWLY PROVIDED E:PART NO.DELETION K:REQUIRED NO. CORRECTION L:APPLICATION SERIAL NO. CORRECTION
T:APPLICATION CORRECTION Z:REMARKS CHANGE



PARTS CATALOGUE NEWS

Honda Motor Co., Ltd. Service Division

PARTS CATALOGUE - CORRECTED

Printed in Japan

CODE NO.	BOOKLET TYPE	13ZH90E9
	MICRO-FICHE	13ZH90EI/FI
PARTS CATALOGUE NEWS	GX270 GX270[PROPANE ENGINE]	
NEWS NO.	031	

Block No.	Ref. No.	Note	Part No.	Description	Reqd. QTY			Serial No.	Parts catalogue code
					(1)	(2)	(3)		
E-16	9	D	18381-Z8S-801	GASKET, MUFFLER (ARRESTER) (THAI LEAKLESS)	1	(1)	-	-----	L1/A, Q1/A, RSS/A, R1/A, S1/A
E-16-1	9	D	18381-Z8S-801	GASKET, MUFFLER (ARRESTER) (THAI LEAKLESS)	1	(1)	-	-----	LWD1/A, L1/A, Q1/A, R1/A, S1/A
E-16-2	8	D	18381-Z8S-801	GASKET, MUFFLER (ARRESTER) (THAI LEAKLESS)	-	(1)	-	-----	L1/A, Q1/A, R1/A, S1/A

NOTE A:PART NO. CHANGE D:NEWLY PROVIDED E:PART NO.DELETION K:REQUIRED NO. CORRECTION L:APPLICATION SERIAL NO. CORRECTION
T:APPLICATION CORRECTION Z:REMARKS CHANGE



PARTS CATALOGUE NEWS

Honda Motor Co., Ltd. Service Division

PARTS CATALOGUE - CORRECTED

Printed in Japan

CODE NO.	BOOKLET TYPE	13ZH90E9
	MICRO- FICHE	13ZH90EI/FI
PARTS CATALOGUE NEWS	GX270 GX270[PROPANE ENGINE]	
NEWS NO.	032	

Block No.	Ref. No.	Note	Part No.	Description	Reqd. QTY			Serial No.	Parts catalogue code
					(1)	(2)	(3)		
E-12	5	D	19610-ZH9-D40ZE	COVER COMP., FAN *T80*..... BAKELITE ORANGE	1	-	-	-----	ES3/A

NOTE A:PART NO. CHANGE D:NEWLY PROVIDED E:PART NO. DELETION K:REQUIRED NO. CORRECTION L:APPLICATION SERIAL NO. CORRECTION
T:APPLICATION CORRECTION Z:REMARKS CHANGE



PARTS CATALOGUE NEWS

Honda Motor Co., Ltd. Service Division

PARTS CATALOGUE - CORRECTED

Printed in Japan

CODE NO.	BOOKLET TYPE	13ZH90E9
	MICRO-FICHE	13ZH90EI/FI
PARTS CATALOGUE NEWS	GX270 GX270[PROPANE ENGINE]	
NEWS NO.	033	

Block No.	Ref. No.	Note	Part No.	Description	Reqd. QTY			Serial No.	Parts catalogue code
					(1)	(2)	(3)		
E-3	2		15510-ZE2-053	SWITCH ASSY., OIL LEVEL	1	-	-	----- 2471791	ES4, RA3, VS5
					1	-	-	2438530 2471791	ESS/A, ES1/A, ES3/A, HX/A, LX/A, PX/A, QX/A, QXE/A, QXE9, QXK RX/A, SX/A, SXE/A, VKK, VMT/A, VPK, VS3, VS4, VX/A, VXE8, VXK VXU/A
					-	(1)	-	2438530 -----	Q1/A, S1/A
	A		35480-ZF6-003	1	-	-	2471792 -----	ESS/A, ES1/A, ES3/A, ES4, HX/A, LX/A, PX/A, QX/A, QXE/A, QXE9 QXK, RA3, RX/A, SX/A, SXE/A, VKK, VMT/A, VPK, VS3, VS4, VS5 VX/A, VXE8, VXK, VXU/A

NOTE A:PART NO. CHANGE D:NEWLY PROVIDED E:PART NO.DELETION K:REQUIRED NO. CORRECTION L:APPLICATION SERIAL NO. CORRECTION
T:APPLICATION CORRECTION Z:REMARKS CHANGE



PARTS CATALOGUE NEWS

Honda Motor Co., Ltd. Service Division

PARTS CATALOGUE - CORRECTED

Printed in Japan

CODE NO.	BOOKLET TYPE	13ZH90E9
	MICRO-FICHE	13ZH90EI/FI
PARTS CATALOGUE NEWS	GX270 GX270[PROPANE ENGINE]	
NEWS NO.	034	

Block No.	Ref. No.	Note	Part No.	Description	Reqd. QTY			Serial No.	Parts catalogue code						
					(1)	(2)	(3)								
E-16	3		18320-ZE2-W01	PROTECTOR COMP., MUFFLER (STD.)	1	(1)	1	-----	HA, HAP, HAP/A, HAQ, HA2, HA2/A, HEA, HEA2, HEA2/A, HEA8 HEA8/A, HH, LH, LHB1, LHB3, LHE, LHQ4, LJ, LJC, LJC/A, LJG, LSS LT, LT/A, LW, LWD, L1, PA, PAE2, PAE2/A, PA2, PA2/A, QA, QAB1 QAB3, QAB3/A, QAE, QAE2, QAE2/A, QAE6, QAE6/A, QAG, QAG/A QAG2, QAG2/A, QAQ, QAQ4, QAQ4/A, QAR2, QAR2/A, QA2, QA2/A, QD QH, QH/A, QHC, QHE, QHE4, QHE4/A, QHP1, QHQ4, QHQ4/A, QHR QHR/A, QHR4, QHR4/A, QHZ, QHZ/A, QH26, QH26/A, QL2, QMH, QMH/A QP, QP/A, QT, QT/A, QX26, QX26/A, Q1, Q2, RA, RA2, RA2/A, RD, RH RHE, RHE4, RHE4/A, RHQ4, RHQ4/A, RH26, RH26/A, RSS, R1, SD, SH SHE, SHEZ, SHQ4, SHQ4/A, SJ, SJG, SK, SKE1, SMD, SMX2, SN, SN/A SW, SWC4, SWC4/A, SWE, S1, VA, VAG2, VAG2/A, VAW, VAW1, VA2 VA2/A, VDE, VDE2, VDE2/A, VH, VMA4, VME2, VME2/A, VME4, VM2 VM2/A, VWA, VWA2, VWA2/A, VWN2, VWN2/A, VW12, VW12/A, VW22, V1 WMA4, WMT8, WMT8/A, WXE8, WXE8/A, W1, W1/A	1	(1)	-	-----	2484724	LH/A, LHB5, LHE/A, LJ/A, LJG/A, LW/A, L1/A, QD/A, QHB5, QHP1/A Q1/A, RA3, RD/A, RSS/A, R1/A, SD/A, SH/A, SJ/A, SJG/A, S1/A
		A	18320-ZE2-W02	1	(1)	-	2484725	-----	LH/A, LHB5, LHE/A, LJ/A, LJG/A, LW/A, L1/A, QD/A, QHB5, QHP1/A Q1/A, RA3, RD/A, RSS/A, R1/A, SD/A, SH/A, SJ/A, SJG/A, S1/A					

NOTE A:PART NO. CHANGE D:NEWLY PROVIDED E:PART NO. DELETION K:REQUIRED NO. CORRECTION L:APPLICATION SERIAL NO. CORRECTION
T:APPLICATION CORRECTION Z:REMARKS CHANGE

PARTS CATALOGUE NEWS

BOOKNo. : 13ZH90E9

Block No.	Ref. No.	Note	Part No.	Description	Reqd. QTY			Serial No.	Parts catalogue code
					(1)	(2)	(3)		
E-16-1	3		18320-ZE2-W61	PROTECTOR COMP., MUFFLER	1	(1)	1	-----	ES1, HX, HXQ4, HXQ4/A, HX26, HX26/A, HX8, HX8/A, LTJ, LWD1, LX, LXE, LXE/A, LXE8, LXE8/A, LXQ4, LXQ4/A, LXU, LXU/A, LXZ, LX16, L1, L1/A, PX, PXE8, PXE8/A, PXU, PXU/A, PX26, PX26/A, QE, QE/A, QME2, QME2/A, QSC, QSC9, QSC9/A, QSE, QSE/A, QSE2, QSE8, QSE8/A, QWA2, QWA4, QWA4/A, QWH2, QWH2/A, QX, QXB, QXB/A, QXB6, QXB6/A, QXC, QXC4, QXC4/A, QXC6, QXC6/A, QXC9, QXC9/A, QXE, QXE4, QXE4/A, QXE6, QXE6/A, QXE8, QXE8/A, QXQ4, QXQ4/A, QXU, QXU/A, Q1, Q2, RSC2, RSC2/A, RX, RXP, RXP/A, RXQ4, RXQ4/A, RXU, RXU/A, R1, R1/A, SE, SE/A, SMC4, SMC4/A, SME1, SME1/A, SME6, SME6/A, SWA4, SX, SXB, SXB/A, SXE, SXE8, SXE8/A, SXE4, SXE4/A, SXE8, SXE8/A, SXQ4, SXQ4/A, SXU, SXU/A, SX2, S1, VD16, VEB6, VEB6/A, VKB2, VKB2/A, VNG1, VNG1/A, VNT2, VNT2/A, VSD, VSD/A, VX, VXB, VXB/A, VXB2, VXB2/A, VXE, VXE8, VXE8/A, VXE4, VXE4/A, VXE6, VXE6/A, VXE8, VXE8/A, VXP, VXP/A, VXQ4, VXQ4/A, VXTB, VXTB/A, VXU, VXU1, VXU1/A, VX26, V1, W1, W1/A
					1	(1)	-	----- 2484724	ES1/A, HX/A, LWD1/A, LX/A, PX/A, QX/A, QXE/A, QXE9, QXK, Q1/A, RX/A, SX/A, SXE/A, S1/A, VX/A, VXE8, VXE8/A, VXU/A
		A	18320-ZE2-W62	1	(1)	-	2484725 -----	ES1/A, HX/A, LWD1/A, LX/A, PX/A, QX/A, QXE/A, QXE9, QXK, Q1/A, RX/A, SX/A, SXE/A, S1/A, VX/A, VXE8, VXE8/A, VXU/A

NOTE A:PART NO. CHANGE D:NEWLY PROVIDED E:PART NO.DELETION K:REQUIRED NO. CORRECTION L:APPLICATION SERIAL NO. CORRECTION
T:APPLICATION CORRECTION Z:REMARKS CHANGE



PARTS CATALOGUE NEWS

Honda Motor Co., Ltd. Service Division

PARTS CATALOGUE - CORRECTED

Printed in Japan

CODE NO.	BOOKLET TYPE	13ZH90E9
	MICRO- FICHE	13ZH90EI/FI
PARTS CATALOGUE NEWS	GX270 GX270[PROPANE ENGINE]	
NEWS NO.	035	

Block No.	Ref. No.	Note	Part No.	Description	Reqd. QTY			Serial No.	Parts catalogue code
					(1)	GX270 (2)	(3)		
E-11	1	D	28400-ZE2-W01ZM	STARTER ASSY., RECOIL *T80*. BAKELITE ORANGE	1	-	-	2475695 -----	ES3/A
	2	D	28410-ZE2-W01ZM	CASE COMP., RECOIL STARTER *T80*. BAKELITE ORANGE	1	-	-	2475695 -----	ES3/A

NOTE A:PART NO. CHANGE D:NEWLY PROVIDED E:PART NO. DELETION K:REQUIRED NO. CORRECTION L:APPLICATION SERIAL NO. CORRECTION
T:APPLICATION CORRECTION Z:REMARKS CHANGE