

Auto Mower / Solar Mower

Workshop Manual 101 91 08-26

Contents

1. Foreword	4
2. Installation instructions	4
2.1. <i>Boundary wire</i>	4
2.2. <i>Auto Mower charging station</i>	5
2.3. <i>Large areas</i>	6
2.4. <i>Sloping areas</i>	6
2.5. <i>Separate working areas</i>	7
2.6. <i>Compatibility with 1995 model Solar Mower</i>	7
2.7. <i>Search loop size</i>	8
2.8. <i>Narrow passages</i>	10
2.9. <i>Making a professional installation</i>	13
3. Start-up and charging	13
3.1. <i>Searching for charging station</i>	13
3.2. <i>Recharging Auto Mower for first time</i>	13
3.3. <i>Recharging Solar Mower for first time</i>	13
4. Supplementary commands	14
4.1. <i>Find forgotten code</i>	14
4.2. <i>Demo mode</i>	14
4.3. <i>Auto Mower charge commands</i>	14
4.4. <i>Mow secondary area</i>	14
4.5. <i>Run further over boundary loop</i>	14
4.6. <i>Running without a loop installation</i>	15
4.7. <i>Resetting</i>	15
5. Maintenance	15
6. Adjacent installations	15
6.1. <i>Solar Mower 1998 model onwards</i>	15
6.2. <i>Auto Mower 1998 model onwards</i>	16
6.3. <i>Solar Mower 1995 model</i>	16
6.4. <i>Synchronising Auto Mower areas</i>	16
7. Energy and the environment	17
8. Battery technology	17
8.1. <i>General</i>	17
8.2. <i>Battery connector</i>	17
8.3. <i>Testing the battery capacity</i>	18
9. Loop system	19
9.1. <i>Operation</i>	19
9.2. <i>Installation mode</i>	19
9.3. <i>Interference in the loop system</i>	20
10. Wiring and component layout	21
11. Mower programs modes	24
11.1. <i>Charging mode</i>	24
11.2. <i>Night mode (Solar Mower only)</i>	24
11.3. <i>Normal mode</i>	24
11.4. <i>Test mode</i>	24
12. Troubleshooting	24
12.1. <i>General</i>	24
12.2. <i>Test mode</i>	25
12.3. <i>Volatge in the AutoMower's power supply</i>	26
12.4. <i>Symptom charts</i>	27
13. Messages and settings	36
14. Differences between different year models	37
14.1. <i>Differences on 1999 model mowers</i>	37
14.2. <i>Differences on 1998 model mowers</i>	38
14.3. <i>Upgrading to model 2000</i>	39
15. Service aids	39

1. Foreword

The purpose of this document is to serve as a detailed supplement to the operator's manual. In order to get the maximum benefit from it you should first read the operator's manual carefully. The intended target group is product managers and service personnel. The first chapters in particular contains very important information also for salespeople and dealers. This document replaces the 1999 edition.

2. Installation instructions

2.1. Boundary wire

Parallel wires that run to an island or generator must be laid very close together, and if stapled in position should be held by the same staples. If they lie some distance from each other (> 5 mm) the mower may in certain situations turn around (wires running to an island) or escape from the area (wires running to a generator). The sensitivity of the mower to the spacing of parallel wires leading to an island depends on the distance to the rest of the boundary wire, and its layout. In many cases the wires can be up to 10 cm apart without causing the mower to turn, but to ensure reliable installation in all situations we recommend a maximum of 5 mm.

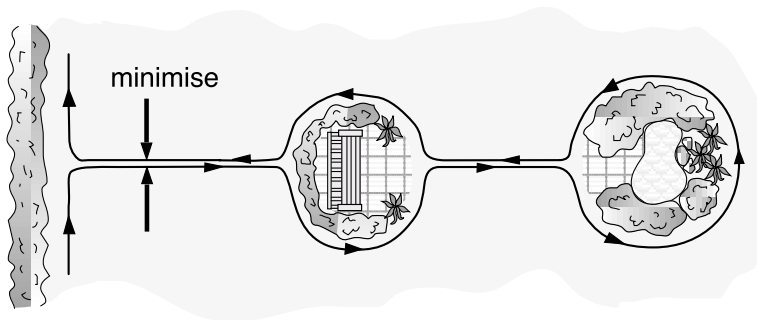

It is a good idea to set aside extra wire in a couple of places especially near the charging station. This allows small adjustments to be made in the future. Route the cable as shown in the figure below. Parallel wires must be routed close together.

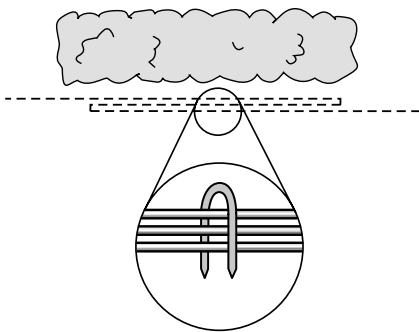

If the lawn is divided into several sections then the wire must be laid to form a series of islands.

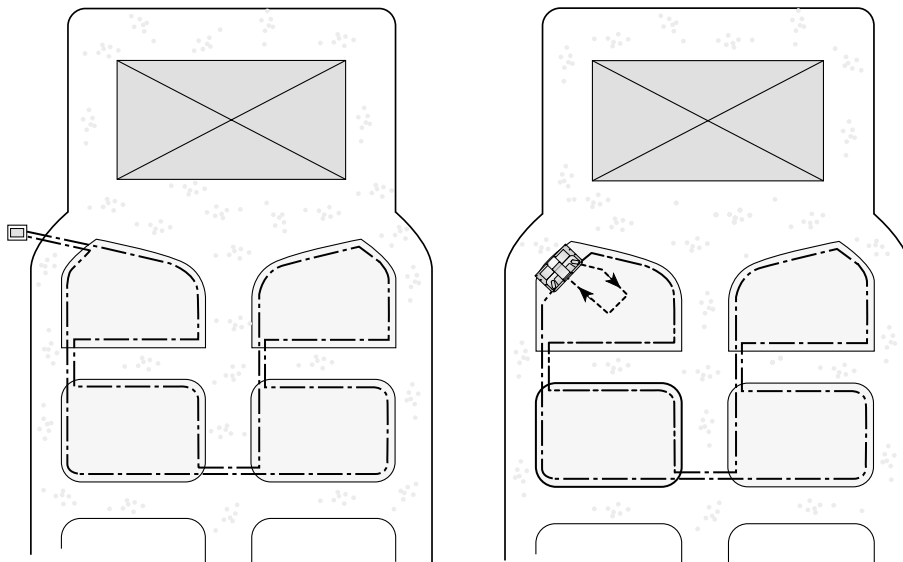

2.2. Auto Mower charging station

The ground a metre or so in front of the charging station must be level or slope slightly towards the charging station. This is necessary because the mower rebounds gently from the charging station and might otherwise stop a slight distance away from the charging station, preventing the mower from making contact with the contact plates. It is also important that the area in front is flat and that the charging station does not lean to one side. This is to ensure that the mower's charging pins make the best possible contact with the contact plates of the charging station.

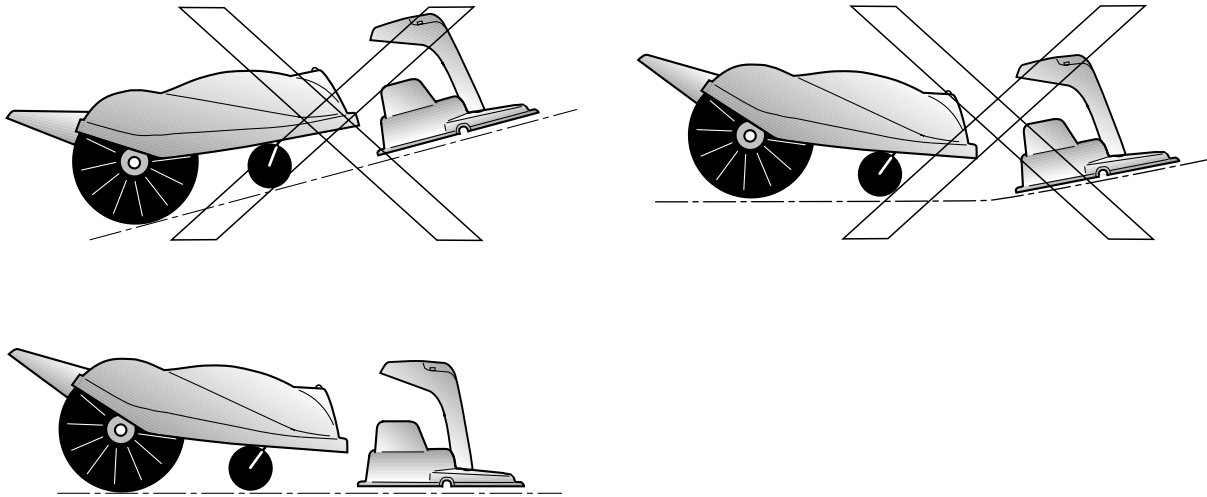

If the charging station is placed against a wall it is important that the boundary wire is installed so that the mower cannot run into the area immediately to the side of the charging station. Otherwise the mower may get caught on the top of the charging station towers.

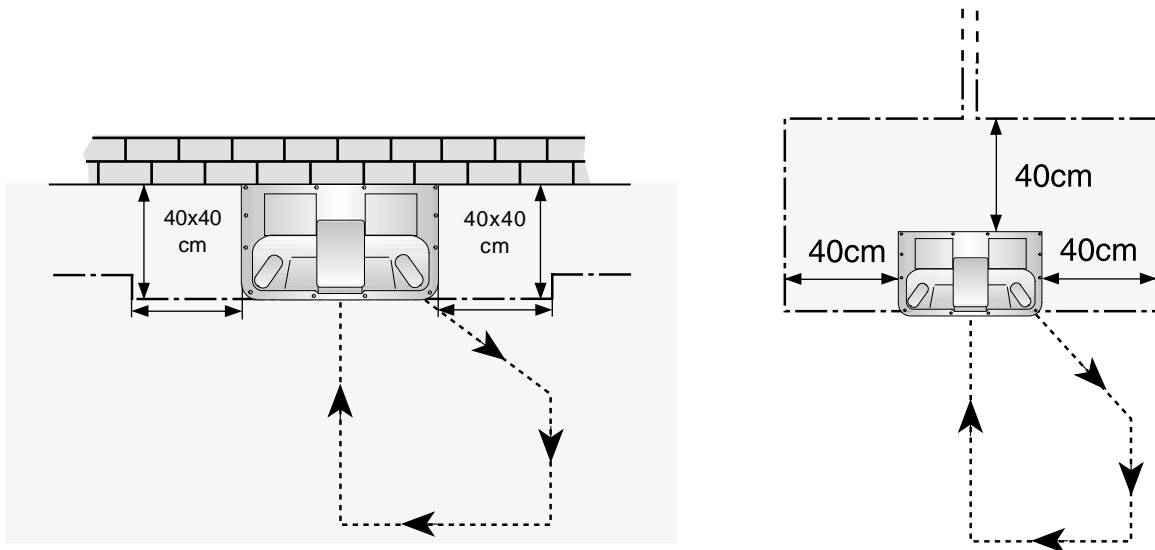

It is not necessary to place the charging station against a wall or at the edge of the lawn, as shown in most of the illustrations. It can also be placed in an island, but the island must be large enough so that the mower cannot drive into the charging station from behind.

The battery life will be prolonged if it is charged at as low a temperature as possible. It is therefore an advantage if the charging station is placed in the shade during the hottest hours of the day. It should also be remembered that the ground in front of the charging station can become rather worn with time.

If the mower does not make proper contact with the contact plates of the charging station or loses contact during charging, it will leave the charging station. It will then start searching for the station again in an attempt to dock properly and make better contact. As usual the cutting disc will not turn while the mower is searching for the charging station. If the mower loses contact with the charging station more than four times in one complete hour the installation is considered unsatisfactory and the mower will then stop adjacent to the charging station and signal the error message “cannot find charging station”.

2.3. Large areas

The operator's manual states a maximum area of 1200-1500 m². The mower can, however, cover larger areas, up to 2000 m², depending on a number of factors:

- The geometric complexity of the area. Are there many trees, flower beds, narrow passages, etc.?
- How shady is the plot (Solar Mower only)?
- How fast does the grass grow? What's the climate like, is the lawn fed regularly, etc?

If you are unsure, the best way to find out is to try. If the area is so big that it requires several mowers then they can be combined in a variety of ways. In the case of the Solar Mower, several machines can work within the same boundary wire, as long as the distance from the mower to the nearest length of wire never exceeds 35 m.

Auto Mower model 2000 can be programmed so that two mowers share one charging station. Both mowers can then work over a common area of 2400-3000 m² depending on the same factors mentioned above. The mowers are set for "double operation" by entering *8#1#, and are reset with *8#0#. You should avoid using the timers if possible, but if you must use them the clocks and timers on both mowers must be synchronised. The advantages of "double operation" compared to two separate installations are as follows:

- Cheaper.
- No synchronisation of systems necessary.
- Simpler installation as only one charging station and one search loop are required.

Note that the incoming search loop must lay straight for about 2 min front of the charging station to give good operation.

In the case of the Auto Mower model 98-99 it is not possible to let several mowers work together and share a charging station. Instead, they must each have separate adjacent areas, each with its own charging station. See chapter 6.4. The third option is to combine one Auto Mower with any number of Solar Mowers.

2.4. Sloping areas

The mowers can work on slopes with an incline of 15°, Auto Mowers a little more, Solar Mowers somewhat less. The mowers can be fitted with accessory weights that can be added in steps of 200-400 g (Art.No. 535 09 11-01) to allow mowing on greater inclines. Of course, you should use as little extra weight as possible to mow the slopes in question. The mower will run a little faster downhill and in doing so come further over the boundary wire and may encounter problems in returning especially in damp weather conditions. It is therefore an advantage if the slope is not too steep just where the boundary wire is installed.

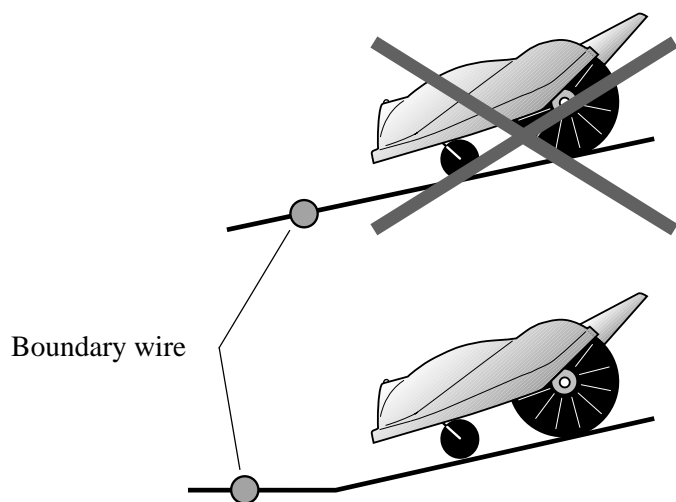
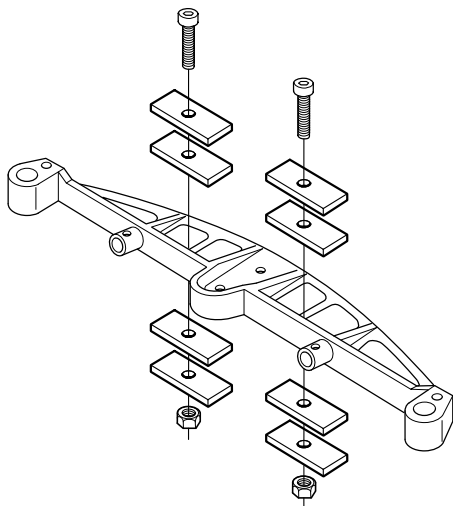

2.5. Separate working areas

Naturally a single mower can be used in several areas if it is carried by hand between them. If they are close together then one area can be made a secondary area by extending the boundary wire. This applies to both the Auto Mower and Solar Mower.

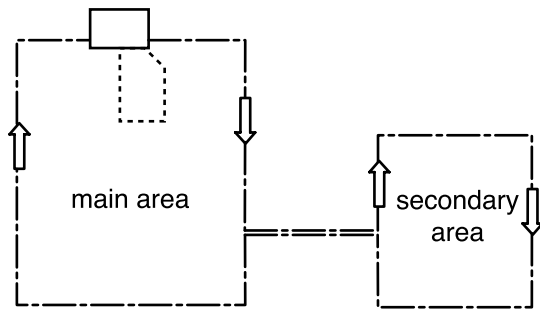

If the areas are far apart it will be necessary to move the generator or charging station between the two areas or buy an additional generator (article number 535 05 67-01) or charging station (article number 535 09 10-01). The signal from the boundary wire is identical for both the Auto Mower and Solar Mower, if it is not necessary to recharge the Auto Mower in the secondary area it may be easier and cheaper to install a generator there to power the boundary wire.

If a single charging station is installed in either of the areas it will be necessary to do the following: In order to fully charge the Auto Mower and prevent it from setting off again when it is fully charged you must dock the mower with the charging station and enter the command * 33 #. The mower will then reverse out and stop in front of the charging station once it is fully charged. The mower can then be carried to the secondary area, preferably after switching the ON/STOP switch to STOP. When the mower is placed in the secondary area and the personal code is entered (if the switch was set to STOP) the Auto Mower will continue working until the battery is drained, and will then stop and display the fault code “cannot find charging station”. If you enter *33# when the mower is not in the charging station it will continue to mow until the battery is discharged, stop and give the fault code.

The command to “mow secondary area” can be cancelled with the command * 34 #. If the mower has drained its battery you will have to dock the mower with the charging station manually. If there is still some charge in the battery, for example if it has been interrupted while mowing the secondary area, then it will start searching if necessary for the charging station by itself once you have keyed in * 34 #. This naturally assumes that the mower has been placed back in the main area. The error message “cannot find charging station” returns the mower automatically to normal mode and cancels the command * 33 #.

A fully charged battery in good condition can run the mower for 2.5–3.5 hours, after you enter the command * 33 #, depending on the cutting resistance.

2.6. Compatibility with 1995 model Solar Mower

Models from 1998 onwards should not be operated with a 1995 model generator, nor should a 1995 model mower be operated with a generator model from 1998 onwards. On the other hand it is technically possible to use the existing boundary wire installation from a later or earlier model. You should remember however that the 1998 model and later models over-run the boundary wire by about 30 cm, while 1995 model mowers will turn before they reach the wire.

2.7. Search loop size

There is an ideal length for the search wire. If it is too long the mower will be forced to follow the search wire for longer than necessary, and if it is too short the mower may not find the charging station. The ideal length depends on

- The size of the working area
- The complexity of the working area; passages, obstacles, etc.

The drawings below show typical search loop sizes depending on the layout of the working area. Measurements denote m^2 of lawn.

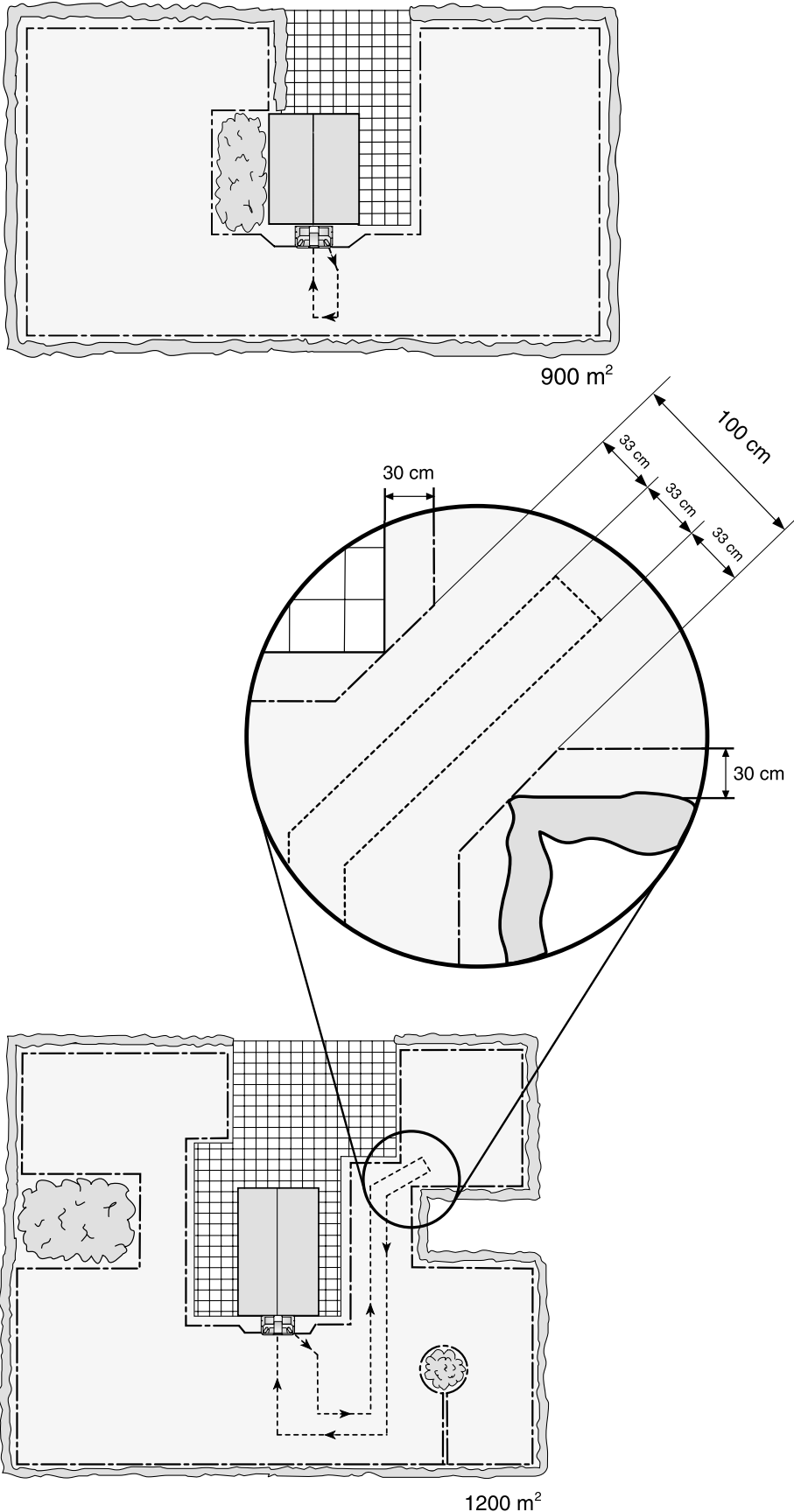

2.8. Narrow passages

One of the biggest challenges of installation is long, narrow passages. The mower must be able to manoeuvre in the passage (more critical for the Solar Mower) and the loop wires must not be laid too close to each other in order to work properly (more critical for the Auto Mower if the search wires are also laid in the passage).

The Solar Mower really needs a passage width of around 2 m in order to manoeuvre properly in any passage longer than 3–4 m. The Auto Mower can cope with around 1.5 m. If these passage widths are reduced the mower will spend a disproportionate amount of time there. A short passage, such as a gateway, can be narrower.

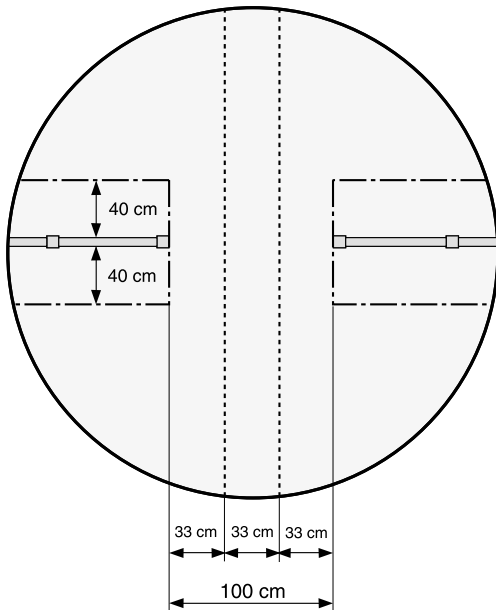

If there are two large areas joined by a narrow passage it may be difficult for the mower to find the entrance to the passage and hence work effectively in both areas. One way of getting the mower to spend roughly the same amount of time in both areas is to place the charging station in the centre of the narrow passage. The mower will turn roughly as often to the left as it does to the right when it leaves the charging station, so it will reach both of the large areas.

It is appropriate to program a special exit angle from the charging station (possible with Auto Mower 2000) if the station is positioned in a narrow passage or aisle. This prevents the mower from frequently stopping unnecessarily in the vicinity of the charging station and in doing so wearing down the grass. In addition, if you activate the “symmetry function” using * 67 # 1 # the mower will run alternately to the right and left in the selected direction.

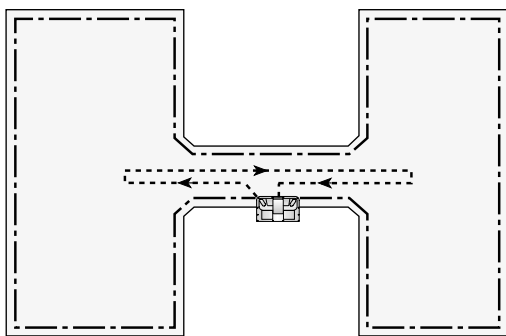

You should, wherever possible, try to maintain the recommended minimum distance between the loops as stated in the operator’s manual, i.e. 70 cm. This dimension has been chosen to give a safe margin of reliability for all combinations of wire installations. An island must not be placed inside the search loop.

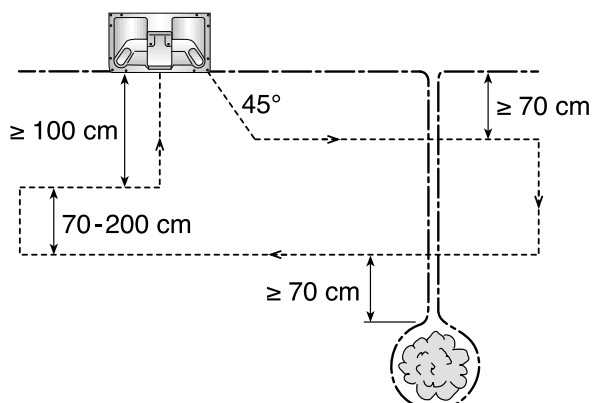

These recommended dimensions do however make it difficult to find space for both the search wire and the boundary wire, not to mention the charging station, in narrow passages. They require a passage width of at least 2.80–3.20 m if the charging station is also placed there, or 2.30–2.90 m, depending on the type of edging used for the passage.

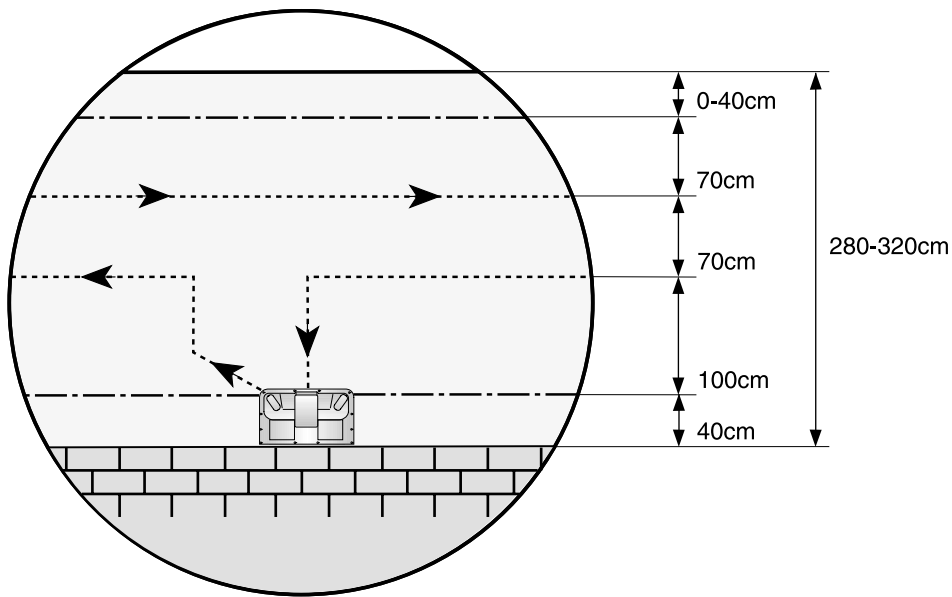

If this width is not available it may be possible to reduce the 70 cm spacing, on condition that the installation is tested carefully before it is considered acceptable. It may be worth trying wire spacings down to 30 cm. If you do reduce the 70 cm spacing you must remember the following, however:

- The incoming search wire must run straight towards the charging station for a distance of at least 85 cm
- The three distances between the boundary wire-search wire-search-wire-boundary wire must be equal

If the mower is able to collide with the edges of the passage, for example a wall, fence or edging stones, etc., it is possible to lay the boundary wire right up to and even outside the edge. This is an advantage since it allows you to lay the wires as far apart as possible. If it is also possible to place the charging station at the side of the passage, for example in a border, it may be possible to install the charging station in a passage as narrow as 90 cm (185 cm if the width of the charging station is included).

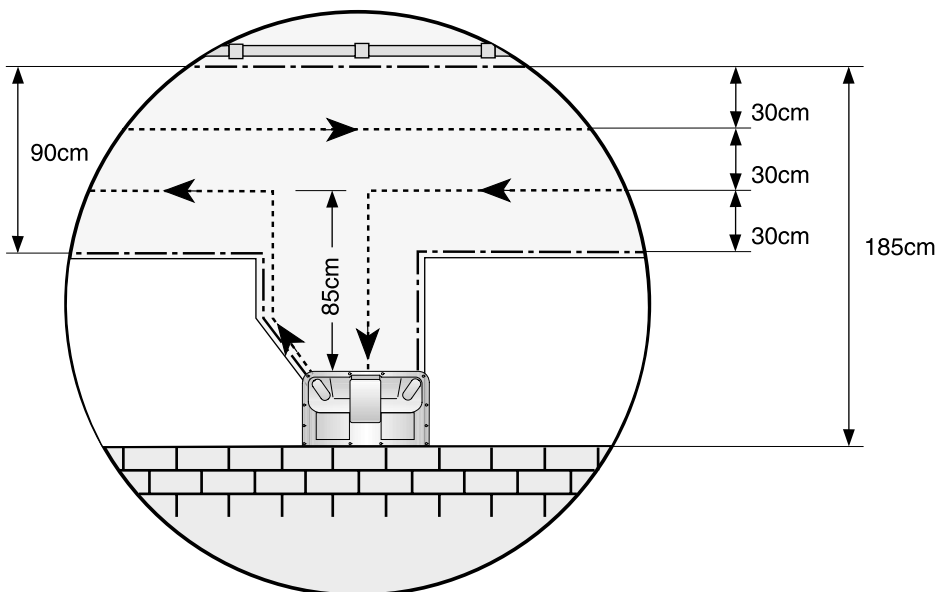

Another option is to place the charging station in one of the large areas and run the search wire into the other area. That way the mower will always find the charging station, but the difficulty will be for it to find the entrance to the passage from the main area when it is mowing.

Passages between large areas should, if possible, be funnel-shaped, with bevelled corners to help the mower find its way into the passage.

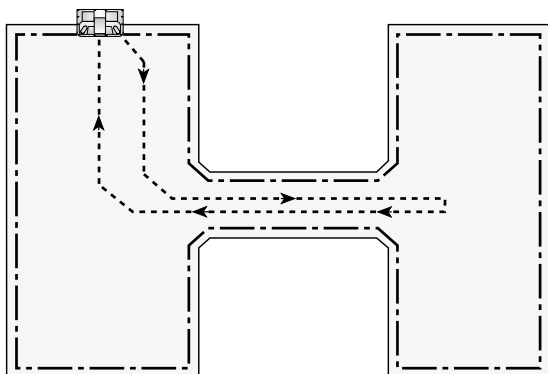

Of the three installations shown below, A is preferable to B and B is preferable to C. With the narrow, right-angled passage shown, in C in particular it is doubtful whether the mower would find its way back to the charging station, especially if the plot was large.

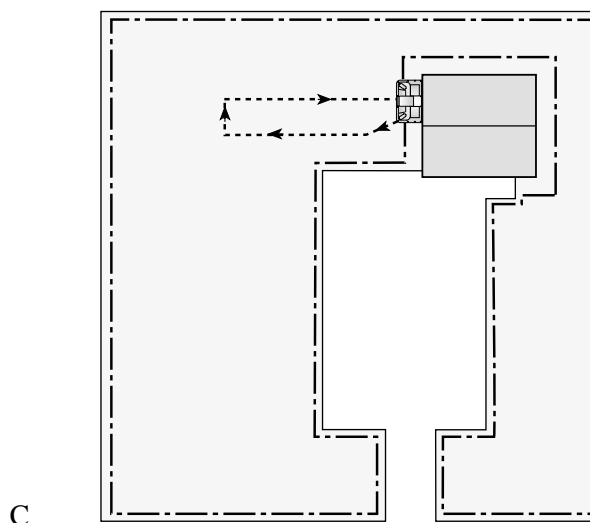
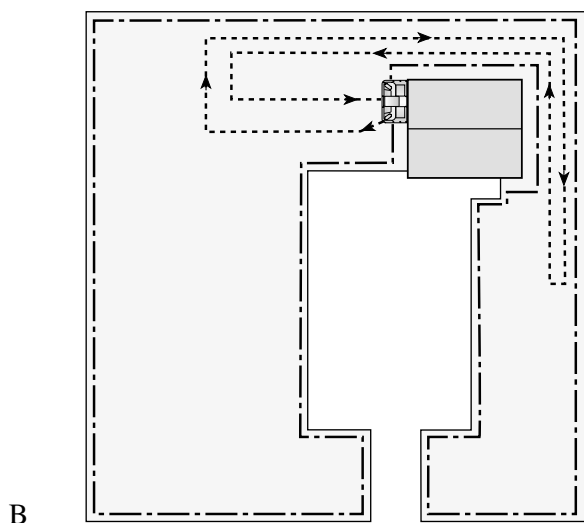
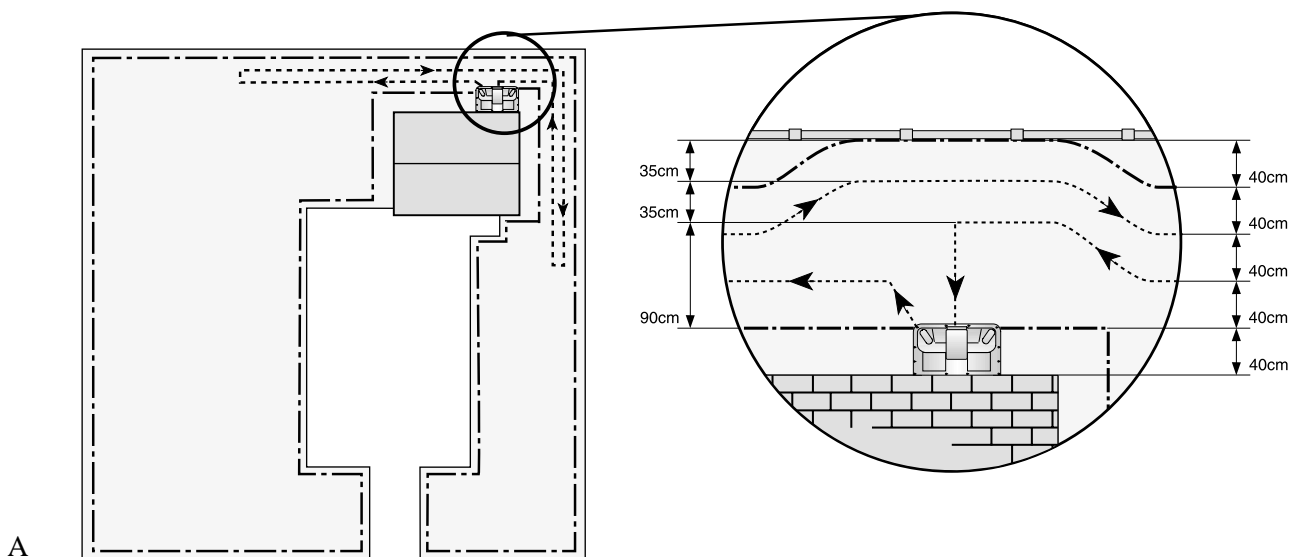

2.9. Making a professional installation

Always use Husqvarna boundary wire. It is double insulated to give improved resistance to ground dampness. A standard single insulated wire will work well for a period, but then faults can start to appear that are difficult to locate. Also use the original connector (Art.No. 535 04 43-01). This is watertight and provides a reliable electrical connection for many years. Besides, it is easy to use and requires no tools. Never make cable joints by twisting together the conductors and insulating with insulation tape. Neither will a screw terminal block or the like give a reliable electrical connection in the long-term. Large packs (500 m, Art.No. 535 09 27-01) and staples (1000, Art.No. 535 09 26-01) are now available. Using a longer cable means fewer joints in the installation, and the larger pack is cheaper than a 150 m reel.

3. Start-up and charging

3.1. Searching for charging station

The Auto Mower will begin searching for the charging station when the battery charge has fallen to 50% of maximum. The battery's available capacity is dependent on the temperature. At a battery temperature of 25°C it is 100% of the nominal capacity, but at 50°C this has decreased to approximately 50% of the nominal capacity. From model 2000 the charging and mowing times are dependent on the ambient temperature. Up to an ambient temperature of about 20°C it will mow for 1-1.5 hours and charges roughly the same or a little longer. Over 20°C the mowing and charging times drop successively.

While it is searching for the charging station its behaviour changes slightly. For example, it will no longer mow in a spiral pattern. The turning angles change so that it can find the charging station quicker (not AM 98-99). See the table of angles on page 33. After 5 minutes of searching (17 minutes on AM 98-99) it will also switch off the cutting motor, thereby saving about 60% of its energy.

In trials carried out by us we found that the Auto Mower normally finds its charging station very quickly, even if the search loop is relatively short in relation to the size and complexity of the area to be mowed.

3.2. Recharging Auto Mower for first time

The Auto Mower is supplied with its battery discharged. When the charging station has been installed the Auto Mower must be docked, with its ON/STOP switch set to STOP, for around 60 minutes. This gives the battery an initial trickle charge of around 150 mA. When this time has elapsed the switch should be set to ON and the personal code must be entered (* 0000 #). Once the mower has accepted the code it will continue charging, this time at the full charging current of around 1.8 A. Since the battery is still relatively drained it will take around 3–5 hours to bring it to full charge. When the mower is operating normally it will take only 1.5–2 hours, or shorter if it is hot, to recharge it fully. This takes less time because the mower starts searching for the charging station when it still has 50% of the full charge.

NOTE! The mower must not be docked with the charging station first time with the ON/STOP switch set to ON. If this happens the initial surge of current through the transformer could trip the fuse.

It is possible to charge the Auto Mower when the charging station is only connected to the power supply, i.e. without the search and boundary loops connected. When it is fully charged it will reverse a short distance from the charging station, stop there and signal "cannot detect loop signal".

3.3. Recharging Solar Mower for first time

The Solar Mower is supplied with its battery discharged. After unpacking it should be placed in the sun (outside in bright sunlight) with the rear panel lowered and the ON/STOP switch set to STOP, for around 60 minutes. This gives the battery an initial trickle charge of around 150 mA. When this time has elapsed the switch should be set to ON and the personal code must be entered (* 0000 #). Once the mower has accepted the code it will start mowing or continue charging at the full charging current, up to around 2.5 A, depending on the brightness of the sunlight.

It is possible to recharge the battery with an external charger, either Husqvarna's charger (see chapter 16.1) or a standard battery charger. The battery capacity is 1200 mAh and it should preferably be charged at a maximum current of 0.5 A (charging time 3 hours) to 1 A (charging time 1.5 hours). The battery has a thermal cut-out, but should still not be charged for longer than stated above. When charging with a standard battery charger use the red (+) and black (-) poles. Exercise care so that the battery connector sleeves are not damaged when connecting the charger. Use test cables 535 09 30-01.

4. Supplementary commands

4.1. Find forgotten code

To find a missing code, key in * 40 #, followed by the numbers 1-8 in ascending order. After you key in each number make a note of the number of the LED that lights up. This will give you a series of eight numbers between 3 and 6 (1 and 4 on AM/SM 98). Example: * 40 # 1 [LED 3 lights up] 2 [LED 6 lights up] 3 [LED 4 lights up] 4 [LED 6 lights up] etc. Now enter these eight numbers in the code window in the service programme and read off the correct code.

4.2. Demo mode

In this mode the mower moves about as normal but the cutting disc does not rotate. In the case of the Solar Mower it also means that night mode is disabled, i.e. the mower can continue working in the dark, if there is sufficient charge in the battery.

When the Auto Mower is in demo mode it also finds and leaves the charging station at shorter intervals. It stops for 4 minutes at the charging station and starts looking for the charging station again after 4 minutes of moving around.

To switch to demo mode, enter * 19 # 1 #. To reset the mower, enter * 19 # 0 # or * 21 #.

4.3. Auto Mower charge commands

Command * 31 # forces the Auto Mower to search for the charging station immediately. Just as in normal operating mode the cutting disc stops rotating while the mower is searching. When the battery has been recharged the mower returns to normal operating mode.

If the mower is removed from the charging station before the battery is fully charged it will try to find its way back again with the cutting disc stationary, in other words as if command * 31 # had been given. The same applies if the mower has been switched off for longer than 24 hours (3 hours on models 98—99) and the power switch is turned ON. It will then automatically make its way to the charging station with the cutting disc stationary, even if the battery is almost fully charged.

If you want the mower to drive into the charging station after giving command * 31 # you should place the mower at right angles to the search wire to make sure that it passes over it and detects it. If you place the mower parallel to the search wire with its nose towards the charging station it is quite likely that the sensor will never cross the wire. The mower will not realise that it is driving virtually on top of the search wire and will rebound off the charging station instead of docking with it.

Command * 32 # does the reverse. The mower is forced to switch to normal mode and mows for 60-90 minutes (equivalent to energy consumption of 2.2 Ah), regardless of the battery charge status. If this command is entered when the battery charge status is low the mower could come to a stop with a discharged battery before this time has elapsed. It will then give the error code “cannot find charging station”. If the battery still has some charge at the end of this period the mower will start looking for the charging station again. The cutting disc will rotate as normal when command * 32 # is entered. The command * 32 # is subject to the timer. If you enter the command * 32 # when the mower is programmed to be shutdown by the timer the cutting disc will not rotate. If you wish to force the mower to mow it is better to use the command * 33 #, which does not take the timer setting into consideration.

4.4. Mow secondary area

If the command * 33 # is entered while the mower is in the charging station it will reverse out and stop immediately in front of the charging station when fully charged. When the Auto Mower is next started up, either by opening and closing the cover or by switching the ON/STOP switch ON and entering the personal code in the usual way, it will continue working until the battery is completely drained. The Auto Mower will then signal “cannot find charging station”, which in this case means that the battery is discharged. The mower will remain in the mow secondary area mode even if the cover is opened and closed again or if the ON/STOP switch is activated. All timer settings are ignored in this mode.

The command * 34 # returns the mower to normal mode. If the mower has already given the fault message “cannot find charging station” it must be manually docked with the charging station. If you have switched it out of “mow secondary area” mode by the * 34 # command before it displays this fault message then it will start searching for the charging station itself, as long as the battery still has sufficient charge. The fault message “cannot find charging station” also returns the mower automatically to normal mode and cancels the command * 33 #.

4.5. Run further over boundary loop

The command * 55 # cm # forces the mower to run further over the boundary wire than the 30 cm default setting. Example: * 55 # 20 # tells the mower to run 30+20=50 cm over the wire. The maximum value that can be entered is 39, in other words 69 cm over the wire. Unfortunately it is not possible for the mower to turn earlier.

4.6. Running without a loop installation

It is possible to use the mowers without a loop installation by deactivating the need of having a signal from the loop. This is useful with quick demonstrations and for trouble shooting. Of course, it is important to carefully watch over a mower that has its loop detection switched off. The mower will run forwards until it crashes with something.

Switch off loop detection using the command * 13870 # 0 #. Activate it again with the * 13870 # 118 # 1 # or with * 21 #.

4.7. Resetting

- When the ON/STOP switch is set to STOP it does not change any settings. It is only necessary to enter the four-figure personal code again when the switch is turned ON.
- The command * 21 # resets all settings to the factory defaults. The clock and the four-figure code are not changed however. The timer is set to unlimited mowing.
- If the battery is disconnected the control program is reset. The four-figure code is not changed, but the clock must be set again (* 50 # hhmm #). The timer settings are not changed.

5. Maintenance

Clean the underside of the mowers regularly. Use a brush, compressed air or damp cloth. Do not hose down. The solar panels on the Solar Mower and generator should be wiped clean regularly to prevent impairment of performance.

Check that the blades and cutting disc rotate freely. If the disc does not rotate freely then you should clean around the axle. This may mean that the skid plate and cutting disc must be dismantled.

In the case of the Auto Mower the contact plates on the charging station and the contact pins on the mower itself should be examined once a month to make sure they are clean. If the mower's contact pins are burnt or partly blackened this is a sign of bad electrical contact with the charging station's contact plates. Bend the plates down a little to increase the contact pressure and make sure the mower stands flat and makes good contact with both plates. The contact plates can be cleaned with fine emery cloth, while the pins can be cleaned with emery cloth or a few light strokes with a metal file.

The charging station should be covered or taken inside over winter.

6. Adjacent installations

One drawback with the loop system used for the 1998 model and onwards is that adjacent installations of the Solar Mower and Auto Mower can interfere with each other. The symptom is that the affected mower stops before it crosses its own boundary wire, at the point where it borders the neighbouring installation, and gives the fault message "cannot detect loop signal" or else it crosses both its own and the neighbouring wires and moves into the neighbouring area.

6.1. Solar Mower 1998 model onwards

If there are two neighbouring Solar Mower installations there are two ways of preventing the neighbour's boundary wire from affecting one's own mower:

- Install the boundary wires at least 2 m apart.
- Replace one of the mowers' generator control boxes with a board having a different crystal frequency. This will allow the distance between the adjacent loops to be reduced to 80 cm. The article number for the special frequency control box is 535 08 22-01

Naturally it is also possible to create an area where both mowers can work within the same boundary loop. It is also possible to combine an Auto Mower with a Solar Mower in the same area.

6.2. Auto Mower 1998 model onwards

The Auto Mower's twin loop system makes it more sensitive to interference, and the methods used to get round this are slightly more involved:

- Install the boundary wires at least 8 m apart.
- Synchronise the loop systems. See chapter 6.4.

6.3. Solar Mower 1995 model

The 1995 model Solar Mower navigates using a frequency that is slightly lower than that for the 1998 and later models. Despite this, the boundary wires for adjacent installations must be at least 2 m apart. See the table below.

6.4. Synchronising Auto Mower areas

Synchronisation means giving adjacent loop systems exactly the same frequency, which prevents interference from the neighbouring loop installation. Each charging station still draws its power supply from its own transformer. If the synchronised charging station (1) loses its power supply, or the synchronising wire is damaged, then charging station 2 takes over frequency control and synchronises charging station 3. The distance between charging stations 1 and 3 ought to be at least 8 m in order to allow for the possibility of failure of charging station 2.

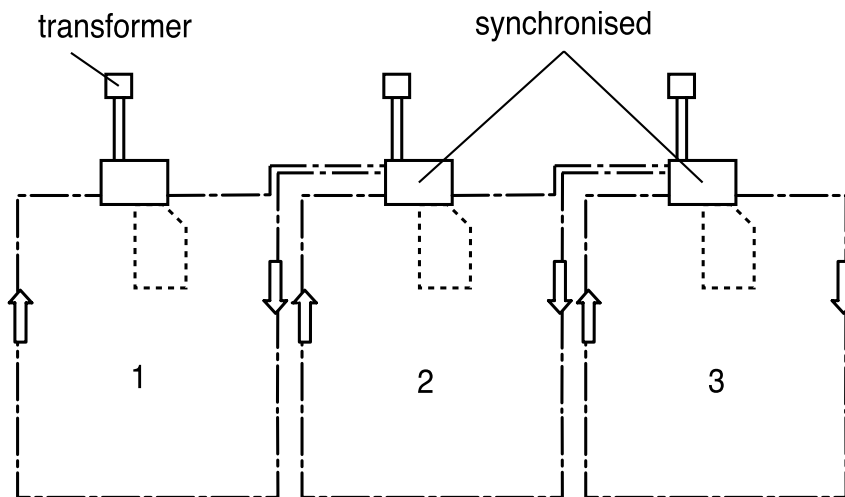

Figure 1. Synchronised charging stations

If the synchronised areas form part of the same lawn, the distance between parallel boundary wires must be 20 cm in order to leave no uncut grass and prevent either mower travelling outside its area. The boundary wires must be twisted together the distance between the working area and the charging station to be synchronised. If necessary it is possible to lay the twisted wires over the working area.

Both wires from the synchronised charging stations are connected to outlets 7 and 8 on the 8 pole terminal underneath of the charging stations.

The maximum loop length from the synchronised system is therefore limited by the run of wire to the synchronised station. The loops can now be laid next to each other so that no uncut grass is left between the areas. Refer to service notice B0000013 for detailed information regarding synchronisation of adjacent installations.

	SM model 95-97	SM model 98 and onwards	AM model 98 and onwards
SM model year 95-97	Distance > 2 m	Distance > 2 m	Distance > 8 m
SM model year 98 and onwards	Distance > 2 m	Distance > 2 m or fit special frequency control box to one of generators	Distance > 8 m or synchronise installations
AM model year 98 and onwards	Distance > 8 m	Distance > 8 m or or let Solar Mower synchronise Auto Mower	Distance > 8 m or synchronise installations

7. Energy and the environment

The Solar Mower and the Auto Mower are both lightweight products, which means that they use little energy for operation and place a relatively small burden on the environment during manufacture and transport. In operation, the Solar Mower does not use any energy other than the sun, although the manufacture of the solar panels themselves does place some additional burden on the environment when compared to the Auto Mower. The energy consumption of an Auto Mower is around 8 kWh per month when fully utilised, i.e. without any timer limits.

8. Battery technology

8.1. General

The Auto Mower starts searching for the charging station when the battery charge has dropped to roughly 50% of its nominal capacity. Normally it finds the search wire quickly, so it usually reaches the charging station and begins charging with the battery still at half charge. Every tenth charge cycle the battery is given a top-up charge, i.e. it is charged up slightly more than the other nine times. The purpose of this top-up charge is to “exercise the battery”. The Solar Mower’s battery also receives a top-up charge.

When the mower is working in long grass the power consumption can reach 3 A. On a well-trimmed lawn it may be under 1.5 A. The mower at a standstill with the switch in the ON position consumes about 0.3 A.

We estimate the life of an Auto Mower battery to be 1,000-1,500 full charge cycles. As the Auto Mower returns to the charging station with half the capacity still remaining in the battery we estimate the battery life to be at least 2000 typical full charge cycles. When the capacity of the battery has dropped to around 75% of its nominal capacity the battery is regarded as having reached the end of its life. The capacity of the battery is normally a little lower when it is new and when it is used again after a long period of storage.

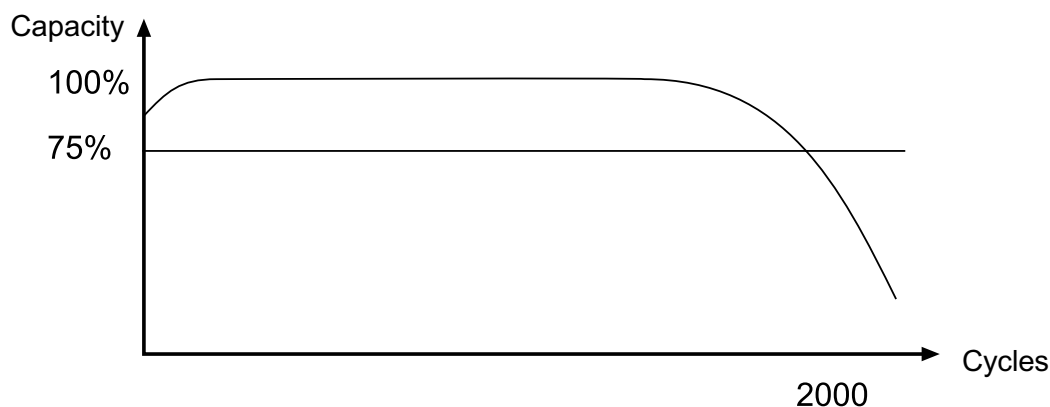

8.2. Battery connector

The table below shows the significance of the six poles in the X14 battery connector. If you intend to measure directly on the battery you should use the Husqvarna battery testing cables 535 09 03-01. This fits at one end on the battery connector and has a standard 4 mm bunch pin plug that fits most multimeter cables at the other. You should be extremely careful if you insert pins, nails or the like in the battery connector. There is a great risk that you will damage the sleeve and with that the entire battery.

Colour, conductor	Pin	Function
Red	1	12 V +
Black	2	12 V earth
Yellow	3	Microprocessor +
Brown	5	Microprocessor earth
Blue	4	Temperature measurement +
Green	6	Temperature measurement -

8.3. Testing the battery capacity

The true condition of the battery can only be determined accurately after it has gone through a complete cycle. Measuring the voltage alone does not give an adequate guide to the condition of the battery. It may have a normal voltage of 12 V or more and still be spent, i.e. have a reduced energy storage capacity.

8.3.1. Testing and reconditioning the battery

On model 2000 and onwards there is a battery tester integrated in the mower's control software. The control software contains two separate, yet similar, functions, one a battery tester the other a battery reconditioner. The battery reconditioner is intended for consumers while the battery tester is intended for service personnel. Both involve the battery being charged–discharged–recharged, and where the discharge is more extensive than with normal operations. Experience shows that the reconditioning function is not essential, but it has been integrated for possible use in the future.

When a test or reconditioning has been performed the discharge capacity is measured and stored in the mower's memory. It can then be read off at any time by service personnel via the service software Rmtest or Rmtest_lite or via the keyboard, see chapter 8.6.4.

The battery is discharged by about 1 A and the output is burnt in the cutting motor, which is not however rotating. A test takes 5-9 hours while it takes between 7-14 hours before the mower returns to mowing with reconditioning. The variation is primarily due to the battery temperature and the charging status when the test/reconditioning starts.

8.3.2. Battery reconditioning

In battery reconditioning mode the mower acts as under normal charging. The cover must be down, it has a normal charging sound and once the reconditioning is completed the mower returns to normal mowing. If the cover is opened during the reconditioning process it is terminated. Activate reconditioning again by placing the mower in the charging station and entering the command * 71 #.

8.3.3. Battery test

In the battery test mode the operating sound is automatically switched off and the error sound is set to level 1, irrespective of the customer's setting. The cover can be either up *or* down and the LEDs indicate the status with a number of error and information messages. After discharging the battery is recharged so that you avoid having a discharged battery once the tests are complete. However, the LEDs are not on during this phase. When charging is complete the mower starts to beep with the normal operation sounds and all LEDs go out.

The LEDs “run upwards” when charging and “run downwards” when discharging. If the battery temperature is above 35°C when the test is started, the battery tester waits for the temperature to drop and indicates the waiting mode by lighting a number of the red LEDs 3-6. All the LEDs 3-6 come on above 46°C, between 41-46°C the LEDs 4-6 are on, between 36-41°C LEDs 5 and 6 are on while under 36°C only LED 6 is on. The mower does not wait for the temperature to fall below a specific level to start the automatic recharging.

Three different error messages indicate possible problems. LEDs 1, 2 and 3 on means: “Cannot detect a charging current”. LEDs 1, 2 and 4 on means: “Temperature sensor in battery faulty”. LEDs 1, 2 and 5 on means: “Charged too long without reaching full charge (240 minutes)”.

Activate the battery test by placing the mower in the charging station and entering the command * 72 #. If you wish to test several batteries consecutively you must exit and enter the battery test mode again. A battery test in progress can be terminated by entering the command * 99 # or by operating the ON/STOP switch.

8.3.4. Read measured and stored battery capacity

You can directly read off the stored capacity by using the service software Rmtest or Rmtest_lite. The capacity can also be read off from the keyboard. However, the mower must first be put into the test mode by with the command * 70 #. You then read off the total of the lit LED numbers for units, tens, hundreds and thousands and this gives the capacity in mAh. Enter * 1 # to read off the total of the lit LEDs for the units, * 2 # for the tens, * 3 # for the hundreds and * 4 # for the thousands.

Example: If the stored capacity is 4279 mAh you will have the following combination of lit LEDs:

1 # gives LEDs 4+5=9, * 2 # gives LEDs 2+5 or 4+3=7, * 3 # gives LED 2 and * 4 # gives LED 4.

8.3.5. Alternative method

An alternative way of getting a rough idea of the battery condition is to discharge a fully charged battery across a light bulb and measure the burn time. A standard car bulb of 12 V/21 W can be used with a 12 V mower battery. This will give a discharge current of 1.5-1.9 A.

Note! As mentioned earlier you should avoid discharging a battery to less than 1 V/cell, i.e. less than 10 V per mower battery.

The table below shows the theoretical and minimum acceptable discharge times each battery should give when discharged from the fully charged state to 10 V.

	Nominal capacity (Ah)	Suitable charging current (A)	Theoretical maximum burn time (min.)	Threshold good/bad battery (min. burn time)
Solar Mower model year 95	1.1 – 1.3	0.1–0.3	41	30
Solar Mower model year 98 and onwards	1.1 – 1.2	0.1–0.3	35	25
Auto Mower model year 98 and onwards	4.4	0.5–1.5	2 hr 16 min.	1 hr 36 min.

9. Loop system

9.1. Operation

The loop system for the 1998 model and onwards is known as a two-tone system because signals of two different frequencies are sent through the wire loop. The received signal is converted into two different voltages; the area signal and the quality signal. The area signal tells the mower which area it is in, while the quality signal tells it how good reception is. If the quality signal drops below 1.5 V the mower does not take any more notice of the area signal and gives the fault message “cannot detect loop signal”.

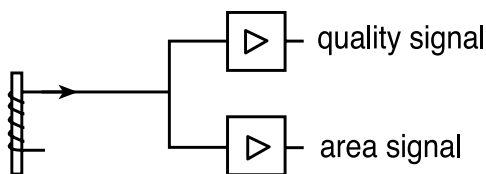

Figure 7. Received signals

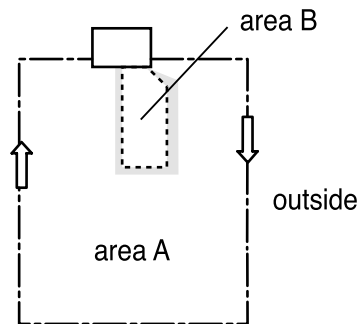

Figure 8. The mower's three areas

The polarity of the signals in the loop wire are varied in such a way that the mower can work out whether it is outside the boundary wire, between the boundary wire and the search loop (area A) or inside the search loop (area B, Auto Mower only). The mower receives, filters and converts the tones into analogue voltage levels, which vary depending on the area the mower is currently in. This system ensures that the mower always knows where it is.

9.2. Installation mode

The installation mode is extremely useful when trouble shooting loop related errors and to find buried boundary and search wires. In installation mode the mower indicates in which of the three areas (A, B or outside) it believes it is in. See the table. When the signal switches between the different areas, the mower's loop sensor is above the loop wire.

Installation mode is activated by the command * 5 # 1 # with the rear cover open. To exit installation mode enter the command * 5 # 0 # or close the rear cover.

Area	Sound signal	LED signal
Outside	Constant beep	—
Area A	—	—
Area B	—	LED 3 on

9.3. Interference in the loop system

Interference in the loop system normally produces one or more of the following symptoms:

- It can twist and turn without passing the loop or any other obstacle.
- It can be at a standstill and signal “cannot detect loop signal”.
- It can give the error message “outside” despite being in either the A or B areas.
- It can go beyond the boundary wire

The magnetic field that is generated by the loop system can be disrupted by a variety of factors. It can be affected by other nearby mower installations, see chapter 6, and it can be affected by magnetic objects in the ground. Steel fences, water and sewage pipes and reinforcing bars can all cause interference. A magnetically conducting material can “short-circuit” the magnetic field, which then passes through the object instead of through the air and hence the mower’s sensor. Interference can also be caused by a defective circuit board in the charging station and, in exceptional cases, a defective control box in the mower. A defective circuit board in the charging station can result in periodic interference in the loop wires. This can be seen by the mower working correctly for a while to then show the fault symptoms described above to finally return to working normally again, etc. If the fault only occurs in a specific area one of the external magnetic objects mentioned above or an adjacent installation will cause it. However, if the fault occurs anywhere in the working area this is probably caused by a faulty component in the mower or charging station. See further in the trouble shooting table 13.4.2 faults 4 and 5 or 13.4.4. faults 15 and 16.

Irrespective of whether the problem is caused by an external disturbance or by a defective circuit board in the charging station the mower will not interpret the area signals and quality signals as it should. You can see where the mower thinks it is by using the installation mode or Service software Rmtest or Rmtest_lite. Depending on if and how it deviates from the true position (A, B, outside) you can continue with the trouble shooting. To correct the problem of a magnetic object it may be necessary to move the wire slightly further away from the object causing the interference. If you cannot see any object, for example in the middle of an open lawn, then you must localise the area of interference. The magnetic field in the problem area can be amplified by bringing in the boundary wire and creating an artificial island in the middle of the weakened area. The island must be no wider than 25 cm, however, so that none of the grass is left uncut. It may be necessary to experiment to find the best size and orientation for the island.

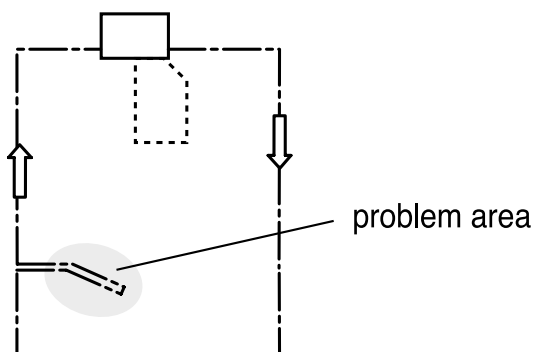

10. Wiring and component layout

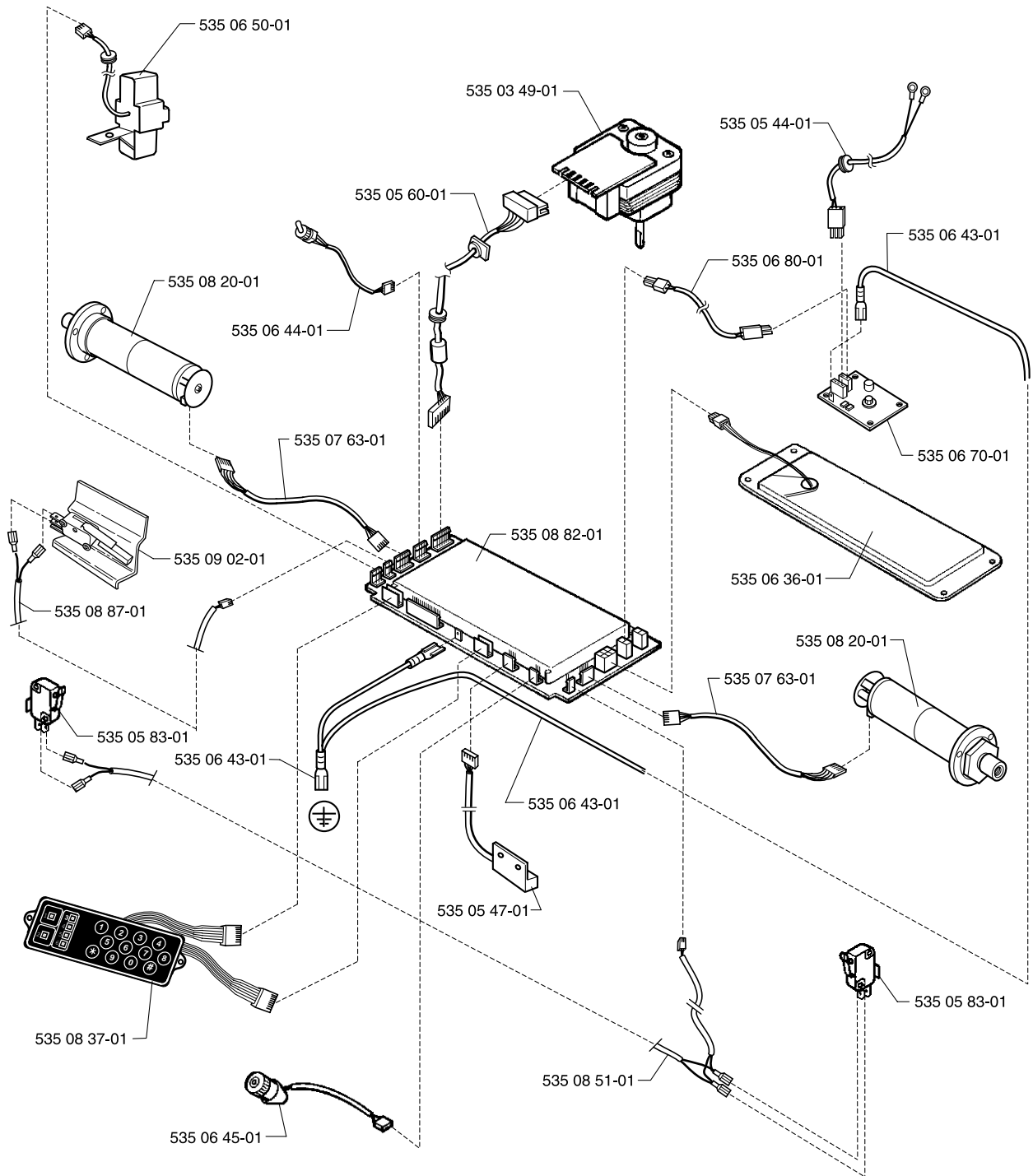

Figure 9. Component layout, Auto Mower 2000

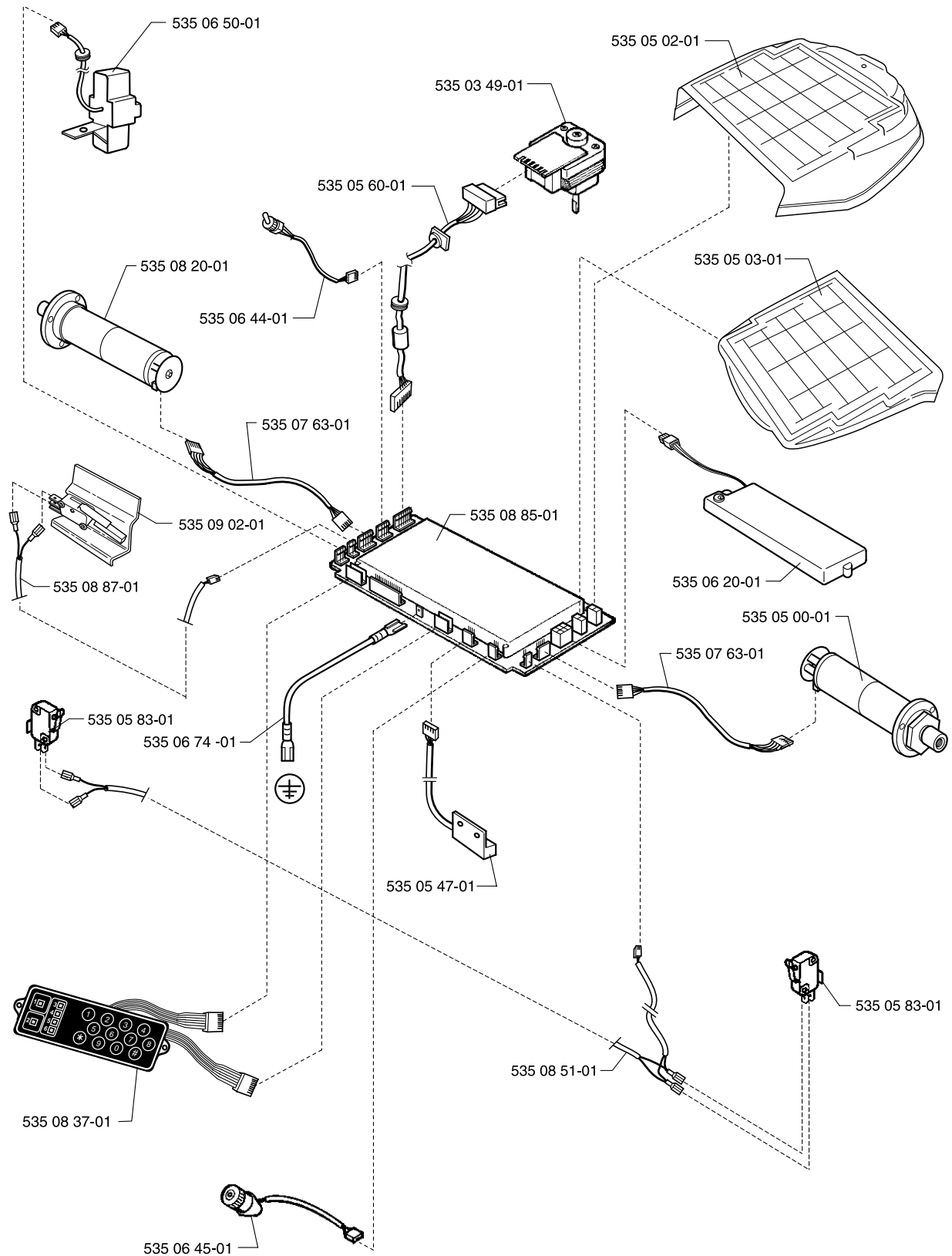

Figure 11. Component layout, Solar Mower 2000

11. Mower program modes

11.1. Charging mode

In charging mode the mower stands still and recharges. The Solar Mower also recharges in normal mode if there is sufficient sunlight. The minimum recharge time is 4 minutes and the maximum is 30 minutes for the Solar Mower and 190 minutes for the Auto Mower. When the Solar Mower's timer is activated it switches the mower to charging mode. The Auto Mower waits at the charging station in charging mode when the timer switches it off. When the battery is fully charged or too hot the charging relay on both mowers will open and the charging current will drop to 150 mA.

11.2. Night mode (Solar Mower only)

This is an energy-saving mode in which the motors and electronics are shut down by the motor relay. Every 15 seconds certain parts of the microprocessor are activated and the current from the solar panels is measured.

11.3. Normal mode

The mower moves around cutting the grass. In the Solar Mower's normal mode the charge status and temperature of the battery are monitored continuously. If the battery temperature approaches a harmful level as a result of overcharging or because of the ambient temperature, charging is stopped and the mower stands still until the temperature drops again.

11.4. Test mode

The conditions for the operation, control and regulation of the various components are ignored and the keyboard and Service program can then be used to give commands and test various functions. Test mode is activated automatically with "Auto test" and "Manual test" from the Service program, or manually by entering a code via the keyboard. See section 13.2

12. Troubleshooting

12.1. General

When you are troubleshooting it is important to gather and give precise descriptions of the fault. Comments such as "just stands there and beeps" are of little help when you want to determine the cause of a fault. If it is a fault that produces an alarm (3 beeps/s) you should always ascertain the LED message. For example "LED 5 on" means Wheel motors jammed, "LED 3 flashing" means mower trapped, etc. Of course it is important not to mix up flashing LEDs and illuminated LEDs.

A new feature on model 2000 is the integrated test function, that allows a great deal of trouble shooting direct via the keyboard. See next chapter.

Husqvarna's PC based service and diagnostic software Rmtest or Rmtest_lite should be used for more advanced service work, trouble shooting and measurement. See chapter 16.2.

To make sure that a problem is not caused by a poor contact, for example due to oxidation, traces of varnish or damage to the socket, the connector in question should be inspected then disconnected and reconnected a few times before continuing with troubleshooting.

If a problem cannot be traced to a hardware fault it may be necessary to initialise the microprocessor. This is done by disconnecting the battery and reconnecting it again.

When a new electrical component is to be fitted it is first advisable to only connect it electrically to ensure that it solves the problem. When this has been established, the component can be fitted mechanically. This applies to wheel motors, cutting motor, loop sensors, keyboard and external buzzer. Simple breaking can be simulated by short-circuiting the actual pin directly on the control box, e.g. panel switch, collision sensors, tilt and lift sensors.

The test cables 535 09 30-01 should be used when measuring from sleeves on the battery, rectifier card, and solar panel connectors to prevent damage to the sleeves.

12.2. Test mode

The test mode is an integrated trouble shooting tool. This can be used to test individual electrical components in the lawn mower. In the test mode the machine should not be considered as a lawn mower, but more as a component tester. This means for example that the normal commands will not work.

The function Manual Test in the Service software Rmtest and Rmtest_lite acts in the same way as the test mode. Put the mower into test mode by keying in the command * 70 #. You exit test mode by entering * 99 #. The mower also leaves the test mode automatically after 3 minutes of inactivity and signals this with a short beep. Each test is activated by keying in * nn # and keep the # key held in. Exception: When testing the wheel motors you must release the # key so that the motor starts. The motor is stopped by pressing an optional key except the # key. When testing the collision, lift and tilt sensors these must be activated manually during the period the # key is held down.

<i>nn</i>	<i>Tested function</i>	<i>Indication</i>
1	Battery test, units	Total number of lit LEDs 1-6 denotes the unit value
2	Battery test, tens	Total number of lit LEDs 1-6 denotes the unit value
3	Battery test, hundreds	Total number of lit LEDs 1-6 denotes the unit value
4	Battery test, thousands	Total number of lit LEDs 1-6 denotes the unit value

To read off the stored battery capacity, code 1-4, see chapter 8.6.4.

10	Collision sensor	Beeps when activated
----	------------------	----------------------

Note that both collision sensors from model 2000 and onwards are connected in parallel to the same computer input X12 marked "Left collision dectector" On model 98-99 they are connected to separate inputs, left to X12 and right to X4 and are testd with codes 10 respective 11.

11	Tilt/Lift sensor	Beeps when activated (Lift sensor USA version only)
----	------------------	---

Tilt, and on USA machines lift sensors are connected in parallel to the same computer input X4 marked "Right collision detector".

12	Right wheel motor direction forwards	Short beep every 100th pulse
14	Right wheel motor direction reverse	Short beep every 100th pulse
16	Left wheel motor direction forwards	Short beep every 100th pulse
18	Left wheel motor direction reverse	Short beep every 100th pulse
optional key	Stops the wheel motors	

It is also important that the beep is audible. It confirms that the tachometer measurement functions.

22	Cutting motor	
24	Internal buzzer	
26	External buzzer	
28	All LEDs	
30	Loop sensor	Beep outside, quiet inside, LED 3 is on in the search area, all LEDs flash with a weak or non-existent signal.

Test of loop sensor is the same as installation mode * 5 # 1 #.

32	Charge current	> 0.25 A = LED 6, > 0.5 A = LED 5, > 0.75 A = LED 4, > 1 A = LED 3
----	----------------	---

The measured charge current is a rectified, yet unfiltered alternating current. This means that one or more LEDs can flicker. Normally LEDs 6 and 5 should be on constantly, i.e. the current's minimum value never falls below 0.5 A. Usually LED 4 is also on constantly, i.e. the current's minimum value never falls below 0.75 A. On the other hand it is common that LED 3 flickers, i.e. the current's minimum value is not always above 1 A See the figure below.

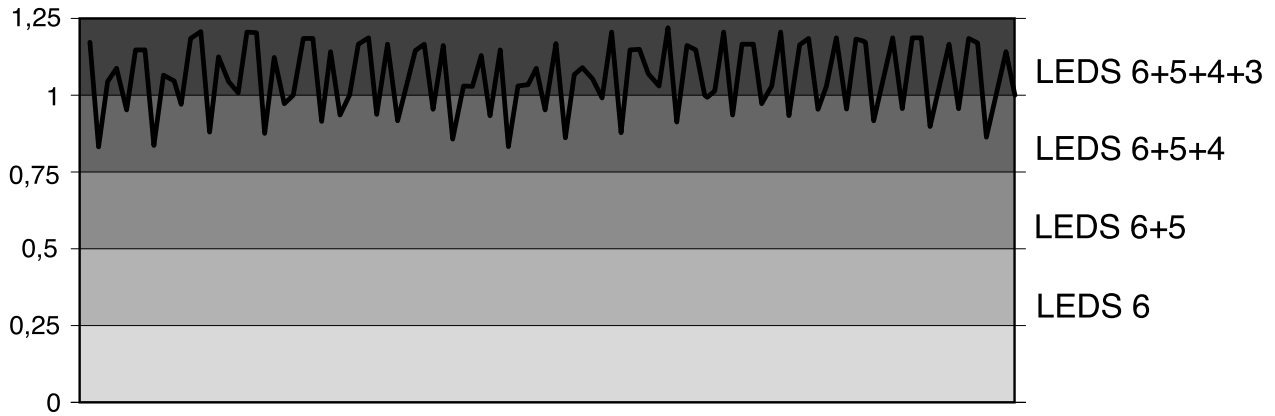

34	Rear cover/panel	Beep when opened
36	ON/STOP switch	Beep in STOP position
99	Exit test mode	

12.3. Voltage in the Auto Mower's power supply

The figure below shows the normal voltage in the entire Auto Mower's power supply chain, from transformer-charging station-rectifier card-control box to the battery.

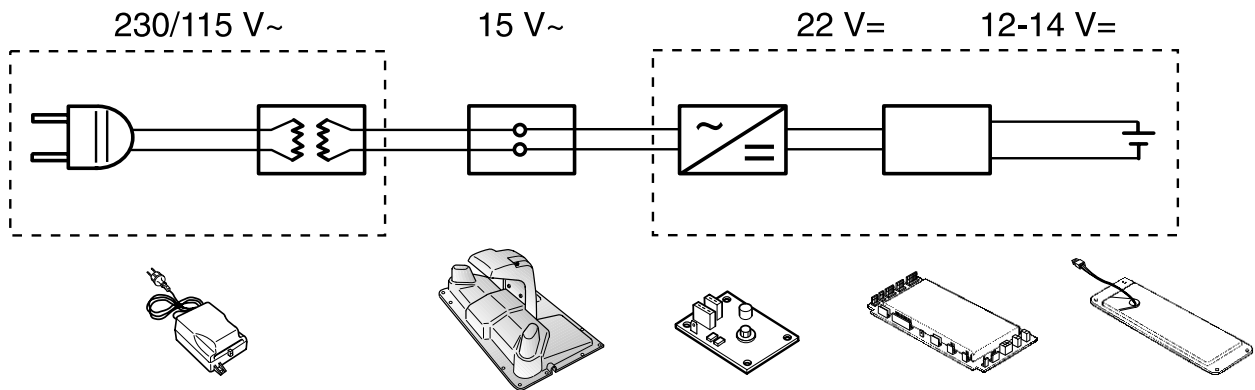

12.4. Symptom charts

12.4.1. Trouble shooting per error message

Error message	Cause	Trouble shooting	Action
<p>1A. "Cannot find charging station". The mower is not next to the charging station. (This error message means the battery is discharged.)</p>	1. Search loop has been made too short in relation to the working area.		Extend the search loop.
	2. Break in the search loop wire.	Use the charging station's test switch to check whether any of the loops are broken.	Join the loop wire.
	3. High ambient temperature. From approx. 25 °C and upwards the capacity of the battery decreases and the mower can have difficulty in finding its way back to the charging station in time.	Is the fault related to a high temperature?	Avoid mowing during the hottest periods of the afternoon by using the timer.
			Place the charging station in the shade if possible.
See further under point 1B. 2-7.		Change to control box 99B, Art. No. 535 08 01-02, which has reworked control software. This software is standard on the 2000 model.	
<p>1B. "Cannot find charging station". The mower is next to the charging station. On Auto Mower models 99-00 the mower gives this error message if it has left the charging station more than four times within a whole hour. It then stands directly next to the charging station. The function does not work in demo mode.</p>	1. Bad contact with the charging station's contact plates.	Check whether the mower's contact pins are blackened by oxide or even weld marks.	Increase the contact pressure by bending the charging station's contact plates and make sure the mower stands flat so that both contact pins make good contact on respective plates.
	2. External cable defective.	Check the cable lugs and cables between the contact pins and the box.	
	Faulty component...	Check the docking procedure using command 31. If the mower does not stay in the charging station but reverses out directly it cannot detect any voltage in the charging station.	
	3. Defective charging station.	Check using a voltmeter whether there is voltage on the contact plates.	If there is no voltage, inspect the cables or replace the circuit board in the charging station.
	4. Problem with the mower's rectifier card.	Check the voltage on the cable to connector X15 on the control box. When the mower is in the charging station the voltage should be approx. 22 V DC.	If there is no voltage, change the rectifier card. If there is voltage see point 4.
	5. Defective control box.	See point 3.	If there is voltage replace the control box.
	6. Break in cable between the contact pins and rectifier card.	Check the cable lugs on the contact pins under the body. Check the voltage on the rectifier card using a voltmeter.	
7. Defective battery	Perform a battery test with the command 72.	Replace the battery if the result is under 3.3–3.5 Ah or the error message is given.	

Error message	Cause	Trouble shooting	Action
2. "Blocked wheel motor"	1. Wheel motor defective. Note the <u>drive</u> motor is defective. The fault is probably in the tachometer circuit (yellow, brown and blue wires).	Start up the mower. It starts with one wheel at a standstill, the driving wheel runs a few <u>decimetres</u> forwards and backwards before the mower stops. Check with test modes 12-14-16- 18.	Check the gap between the Hall sensor and the magnetic disc and check its soldered connections. If no fault is visible replace the motor.
	2. Wheel motor defective. The motor that does not rotate is faulty. The motor can be mechanically jammed or there is a fault in the voltage supply circuit (red and black wires).	Start up the mower. It tries to start up but one wheel only moves a few <u>centimetres</u> forwards and backwards before the mower stops. Check with test modes 12-14-16- 18.	Check the soldered connections on the motor's small circuit board. If no fault is visible replace the motor.
3. "Blocked cutting disc"	1. The disc is mechanically jammed or runs slowly.	Check with test mode 22 whether the motor tries to start, but does not reach full speed due to the disk not rotating freely and easily. To read off the speed, use the service software Rmtest or Rmtest_lite. The nominal speed is 2500 rpm on models 98-99 and 2630 on model 2000.	Remove grass and twigs, etc., and clean. The skid plate and cutting disc may have to be dismantled in order to access the motor axle and bearing correctly.
	2. The control box is faulty	Check with test mode 22. If the motor does not start it is appropriate to test run a separate motor+cable to exclude these components.	Change the control box
	3. Defective cutting motor	See point 2.	Change the cutting motor
	4. Defective cutting motor cables	See point 2.	Change the cutting motor cables

Error message	Cause	Trouble shooting	Action
4A. "Cannot detect loop signal". This occurs only in (a) specific area/s.	1. The loop system's magnetic field is disturbed by a magnetic object. See chapter 10.	Is there are visible objects, e.g. a large iron fence in the vicinity? Use installation mode to see in which area the problem occurs.	Move the loop wire a little further from the disturbing object.
		Could there be magnetic objects, e.g. scrap iron, in the ground? Use installation mode to see in which area the problem occurs.	Amplify the loop system's magnetic field by creating an artificial island. See chapter 10.3.
	2. The mower is disturbed by a neighbouring Auto Mower/Solar Mower installation. See chapter 6.	Disconnect the transformer or the loop generator on the neighbouring installation. Does the problem vanish?	The distance between neighbouring installations must be 8 m (AM-AM or AM-SM) or 2 m (SM-SM). Alternatively synchronise the areas. See chapter 6.4
		Solar Mower: Is the problem greater during the pre/post season, on cloudy days and in the mornings and evenings? Test with a fully charged battery in the loop generator.	If the battery in the loop generator is faulty and/or the generator is placed unsuitably the Solar Mower will be more sensitive to disturbances from neighbouring installations.

<p>4B. "Cannot detect loop signal" This occurs anywhere in the working area. (Auto Mower)</p>	1. Break in boundary wire.	Use the charging station's test switch to check whether any of the loops are broken.	Join the loop wire. It is important that joints are watertight. Use Husqvarna's watertight connectors (535 04 43-01).
	2. Faulty circuit board in charging station		Change to circuit board 2000 (535 08 17-01).
	3. Defective control box		Change the control box.
	4. Defective loop sensor or cables.	Check that the loop sensor's cable is secure. Clean contact X5 by connecting and disconnecting the connector a few times.	Change the loop sensor.
<p>4C. "Cannot detect loop signal" This occurs anywhere in the working area. (Solar Mower)</p>	1. Break in boundary wire.	Use the loop generator's test switch to check whether any of the loops are broken.	Join the loop wire. It is important that joints are watertight. Use Husqvarna's watertight connectors (535 04 43-01).
	2. Solar Mower's loop generator has a drained battery.	Use the loop generator's test switch to check whether a normal beep is heard (=battery ok).	Test with a fully charged battery.
		Check that the loop generator's solar cells are not cracked, dirty and are free from foreign objects.	Change the solar cells or clean.
		Is the problem greater during the pre/post season, on cloudy days and in the mornings and evenings?	The loop generator should have a light and open location. It is important that it is placed as free as possible and is in sunlight during as many hours of the day as possible.
	3. Faulty circuit board in loop generator		Change the circuit board.
	4. Defective control box		Change the control box.
5. Defective loop sensor or cables.	Check that the loop sensor's cable is secured correctly. Clean contact X5 by connecting and disconnecting the connector a few times.	Change the loop sensor.	
<p>5A "Outside" despite the mower being inside the boundary wire. (Auto Mower)</p>	1. An island has been installed incorrectly with crossing wires.	Is the mower in the vicinity of an island when it signals outside? Check the loop signal using installation mode.	Change the cable routing around the island.
	2. Break in boundary wire.	Use the charging station's test switch to check whether any of the loops are broken. NOTE! If the mower functions normally again when the test switch has been actuated the charging station's circuit board must be replaced (models 98-99). See cause 3.	Join the loop wire. It is important that joints are watertight. Use Husqvarna's watertight connectors (535 04 43-01).
	3. Faulty circuit board in charging station	Test using the installation mode whether the mower interprets the right area. See chapter 10.2. Does the behaviour vanish if you press the card on the charging stations test switch?	Change to circuit board 2000 (535 08 17-01).
	4. Defective control box		Change the control box.

5B. "Outside" despite the mower being inside the boundary wire. (Solar Mower)	1. The loop generator has been connected incorrectly.		Switch both the loop's wires on the generator.
	2. An island has been installed incorrectly with crossing wires.	Is the mower in the vicinity of an island when it signals outside? Check the loop signal using installation mode.	Change the wire routing around the island.
	3. The loop generator's circuit board is defective.		Change the circuit board.
	4. Defective control box		Change the control box.

Error message	Cause	Trouble shooting	Action
6. "Trapped" This message is tripped by the collision, tilt or left sensors being actuated many times in a short period.	1. A collision sensor is jammed in the activated mode.	Does the body move in relation to the chassis?	If the body rubs against the box the tube can be deformed and must be straightened.
		Do you hear a "click" when the body is pressed backwards in relation to the chassis?	If not, check that the microswitch is correctly fitted in its seating.
			If not, adjust or replace the arm or thumb screw in the collision tower.
	2. Defective collision sensors or cables.	If the body moves easily and the microswitch clicks the fault is probably electrical and lies in the microswitch or cables. Check with test mode 10 on model 00 (both collision sensors), and 10+11 on models 98-99 with control box 99B (10=left, 11=right-hand collision sensors). Short circuit pins 1 and 2 on connectors X4 respective X12 on the mower in test mode 10/11.	
	3. Tilt sensor (model 2000) jammed in the activated mode.	Do you hear a "click" when the machine is turned upside down? Check with test mode 11.	If not, the tilt sensor is jammed or the weight has become loose.
	4. Defective tilt sensor or cable.	Check with test mode 11.	Change defective parts.
	5. Lift jammed in the activated mode sensor (only USA machines model 2000).	Inspect the microswitch and telescopic function at the front of the mower.	Clean and/or adjust.
	6. Defective lift sensor or cable (only USA machines model 2000).	Check with test mode 11.	Change defective parts.
	7. Defective control box.		Change the control box.
7 "Code missing" despite the code being valid.	1. An unauthorised person has activated the theft alarm. This error message is displayed once the alarm stops.		
	2. ON/STOP switch has been switched.		

8. "Incorrect entry" when the personal code is entered.	3. Defective ON/STOP switch.		Replace the switch
	1. Wrong code entered.	Find the right code using command 40 and contact Husqvarna.	
	2. Defective keyboard.	Press all 12 buttons. Does the mower beep after each key?	If not, replace the keyboard. NOTE! When installing a new keyboard the hole between the box and keyboard holder must be sealed using, silicone.
		Use the service software Rmtest or Rmtest_lite: Check using manual test whether all key respond correctly when pressed.	
	3. Defective control box.		Replace the control box.
9. Solar Mower enters "night mode" despite the sunshine.	1. Solar panel is obviously damaged.	Look at the top of the panel for cracks or damage.	
	Faulty component...	Measure the current that the microprocessor perceives. The limit for night mode lies at 80 mA (falling) and 140 mA (rising). The panel current can be roughly estimated by using test mode 32. If LED 6 is on you have at least 250 mA and the mower should not enter night mode. Use the service software Rmtest or Rmtest_lite (see chapter 16.2) to read off the exact charging current. Alternatively measure a control voltage on the circuit board between pin 2 on connector X16 and the earth pin. The current that the computer perceives is 10x the measured voltage.	
	2. Bad contact on the circuit board connector.	Check the panel cables connectors X16 and X15 visually. Check that the sleeves are secured correctly in the cables' connector housing. Check that the sleeves have not been damaged, e.g. so that the diameter is not bigger. Compare with the other connectors.	Adjust damaged sleeves.
	3. Defective control box.		Replace the control box.
	4. Crack in the solar cells that is hardly visible.	Dismantle the connectors X15 and X16 and measure the current from respective halves using a multimeter. The panels must be in daylight. Artificial light does not give sufficient light flow. The measured current is higher than that in real operations, but still gives an grasp of whether the panel is damaged, i.e. gives a lower current. Bend the panels a little when making the measurement.	Replace the panel half that clearly gives a low current. The difference should then amount to at least 20% in the same lighting.
5. Insufficient insulation between the carbon fibre body (semi-conductive) and the connections between the panel cables and solar cells.	Short-circuit both sleeves in each of the panel connectors X15 and X16 and measure the resistance between them and the body (one of the panel switch rivets). Measure one connector (half panel) at a time. Bend the body a little during measurement. The resistance should be infinite.	If the resistance is low you should check the solar cell connections. Remove the cover from the reinforcing channel in the underside of the panel. Check that none of the soldered joints are touching the body and that the hole is free from contamination.	

12.4.2. Trouble shooting per fault symptom -Charging

Fault symptom	Cause	Trouble shooting	Action
10. Auto Mower does not dock with the charging station but bounces straight out again.	1. Incorrect installation of the search loops or charging station.	Does the mower turn sharply to the right just as it is about to enter the charging station?	If yes, check whether the incoming search loop is routed <u>up on</u> the black section's ramp.
	2. No voltage on the charging station's contact plates.	Check the voltage using a lamp or voltmeter. The voltage should be around 17 V AC.	If there is no voltage, dismantle the charging station's top cover and check the wiring between the circuit board and the contact plates. If no fault is found replace the charging station's circuit board.
	Faulty component in the mower...	Does the mower run straight along the search loop and are the contact plates in the charging station making good contact?	
	3. External cable defective.	Check the cable lugs and cables between the contact pins and box.	
	4. Rectifier card or connector defective.	Dismantle connector X15 from the control box (cable from the rectifier card) and check whether there is voltage when the mower is in the charging station. The voltage should be around 22 V DC.	If there is no voltage replace the rectifier card.
		Check that the sleeves are secured correctly in the cables' connector housing X15. Check that the sleeves have not been damaged, e.g. so that the diameter is not bigger. Compare with the other connectors.	If the sleeve has been heavily deformed the spring will have lost its effect and should not be repaired. Replace the entire cable instead.
	5. Defective control box.	Is there incoming voltage on connector X15?	If yes, replace the control box.
6. Defective battery.	Test the battery with command 72.	Replace the battery if the result is under 3.3-3.5 Ah or an error message is given.	
11. The Auto Mower docks with the charging station but only stays a few minutes before running off again.	1. External cable defective.	Check cable lugs and cables between the contact pins and the box.	
	2. Rectifier card defective.	Check the current by using the service software Rmtest or Rmtest_lite. An approximate test of the current with test mode 32. The current can also be measured using a multimeter. It is easier to dismantle the top cover on the charging station and to connect a multimeter in series with one of the cables between the circuit board and the contact plates. The current should be between approx. 1.2 A (fully charged battery) and 1.8 A (fully discharged).	Change the rectifier card.
	3. Defective battery.	Test the battery with command 72.	Replace the battery if the result is under 3.3-3.5 Ah or an error message is given.

12. The Auto Mower remains in the charging station for long periods.	1. Timer activated.	Switch off the timer and check that the mower comes out.	The mower normally stands in the charging station when the timer switches it off.
	2. Voltage drop to the charging station due to a too long low voltage cable.	Is the wire joined and extended? Check the current by using the service software Rmtest or Rmtest_lite. An approximate test of the current with test mode 32. The current can also be measured using a multimeter. It is easier to dismantle the top cover on the charging station and to connect a multimeter in series with one of the cables between the circuit board and the contact plates. The current should be between approx. 1.2 A (fully charged battery) and 1.8 A (full discharged).	Make the low voltage cable shorter or use a cable with a larger cross section (min 2.5 mm ²).
	3. Defective rectifier card.	Check the current according to point 2.	Change the rectifier card.
	4. Defective battery.	Test the battery with command 72.	Change the battery if the result is under 3.3-3.5 Ah or an error message is given.
13. The Solar Mower remains in the charging station for long periods and mows for short periods despite good light conditions.	1. The cutting motor has an extra high load.	Check that the cutting disc and skid plate can move easily.	Clean grass and dirt from the cutting disk, skid plate and the motor axle.
	2. High ambient temperature (only model 98-99).	Models 98-99 have impaired performance in high ambient temperatures. This happens gradually above approx. 22°C.	Change to control box 99B (535 08 02-02).
	3. Defective battery.		Change the battery.

12.4.3. Trouble shooting per fault symptom — Loop system

Fault symptom	Cause	Trouble shooting	Action
14. Auto Mower runs round inside the search loop.	There are probably one or more breaks in the boundary wire.	Use the charging station's test switch to check whether any of the loops are broken.	Join the loop wire. It is important that joints are watertight. Use Husqvarna's watertight connectors (535 04 43-01).
15. The mower makes irregular movements. It reverses/turns where there are no obstacles or loop wires. It looks like the mower is dancing. This can happen anywhere in the area.	1. Circuit board in the charging station/loop generator is defective.	Test with the installation mode whether the mower interprets the area correctly. See chapter 10.2. Does the behaviour disappear if you press the charging station's test switch briefly?	Change to circuit board 2000: AM 535 08 17-01. SM 535 06 37-01.
	2. Defective control box.		Change the control box.
16A. The mower runs over the boundary wire. This can happen anywhere in the area.	See error 15.		
16B. The mower runs over the boundary wire. This only happens in (a) specific area/s.	1. Local disturbances in the magnetic field where the mower runs out.	Test with the installation mode whether the mower interprets the area correctly. See chapter 10.2.	Adjust the position of the loop.
	2. See error 4A.2		

12.4.4. Trouble shooting per fault symptom — Diverse

Fault symptom	Cause	Trouble shooting	Åtgärd
18. The mower does not start when the rear cover is closed.	1. The panel switch and magnet do not make correctly with each other.	Are the LEDs still on when the cover is closed? Check operation with an open cover and a separate magnet.	Straighten deformed tubes or handles.
	2. Defective panel switch.	Short-circuit pins 1 and 2 on connector X10 with a screwdriver. Does the mower start?	Knock the panel switch lightly (the part <u>not</u> located on the rear cover). Replace the panel switch.
19. The LEDs do not come on and/ or no beep is heard when the keyboard is used. However, when the battery is removed and fitted the normal beep is heard.	1. Bad contact on the keyboard's two connectors.	Check that the two connectors make correctly by disconnecting and connecting them 2-3 times.	Replace the keyboard. Replace the control box. Charge the battery.
	2. Defective keyboard.		
	3. Defective control box.		
20. The mower is completely dead. No beep is heard when the battery is removed and then refitted.	1. Battery fully discharged.	Check the six sleeves in the battery connector. Are any of the sleeves damaged and/or are there signs of soot around them? Wiggle the wires in the battery connector. Is there a bad connection?	Repair the damaged sleeves or change the battery. Replace the battery. Replace the control box.
	2. Battery connector damaged.		
	3. Defective battery.		
	4. Defective control box.		
21. Impaired mowing/charging conditions.	1. Mower height set too low in relation to the length of the grass.		Raise the cutting height. If the mower has not be used for a time and the grass has grown long the cutting height must be raised to then successively lower it as the grass is cut. Preferably you should not mow more than 1-2 cm.
	2. Grass or a foreign object has wound itself around the motor axle.	Do the cutting disc and skid plate rotate easily? To read off the exact speed use the service software Rmtest or Rmtest_lite. Nominal speed is 2500 rpm on models 98-99 and 2630 rpm on model 2000.	Clean the motor axle. The skid plate and cutting disc may have to be dismantled in order to access the motor axle and bearing correctly. It is important that the grass along the edges of the working area is not allowed to grow too long. Otherwise long grass clippings can become entwined around the motor axle.
	3. Defective bearing in the skid plate.	Can you hear abnormal noise from the bearing when the skid plate rotates?	Change to a metal enclosed Z-sealed bearing on the rotating skid plate. Art. no. 535 07 57-02. In many climates the Solar Mower has impaired access to energy compared to the Auto Mower and is therefore more sensitive to high friction in the mowing system. Accordingly, it is recommended changing to a Z-sealed bearing on the rotating skid plate on models 98-99. Standard on model 2000.

	4. Battery defective or worn out.	Auto Mower: Test the battery with command 72.	Change the battery if the result is under 3.3-3.5 Ah or an error message is given.
		Solar Mower: Test the battery with the battery tester.	Change the battery if the result is under 0.82-0.90 Ah or an error message is given.
		Solar Mower: test run with a new battery.	
22. Abnormal noise is heard when the cutting motor is active.	1. Cutting disk is not balanced.	Check that all three blades are seated correctly and not damaged.	Always replace all three blades at the same time.
		Is there dirt, dried grass etc. between the cutting disk halves?	Clean the cutting disc internally by removing the blades and picking out dirt and grass using steel wire of the like.
	2. Defective cutting motor (bearing) .	Dismantle the cutting disk and skid plate. Test the cutting motor with the test mode 22. Do you still hear the abnormal noise?	If yes, replace the cutting motor.
23. The Solar Mower does not start when used for the first time or after winter storage.	1. Battery "slow starting".		Charge the battery externally approx. 10-20 minutes with 1 A. Use an Auto Mower in the charging station as the charger if possible. It has a compatible battery connector.

13. Messages and settings

<i>LED signal</i>	<i>Beep signal</i>	<i>Meaning</i>
Error messages		
3 on	(3 beeps/1 s)	No code
4 on	(3 beeps/1 s)	Cutting disc jammed
5 on	(3 beeps/1 s)	Wheel motors jammed
6 on	(3 beeps/1 s)	Cannot detect loop signal
3 flashing	(3 beeps/1 s)	Mower trapped
4 flashing	(3 beeps/1 s)	Outside boundary loop, or loop or incorrectly installed
5 flashing (AM)	(3 beeps/1 s)	Cannot find charging station
6 flashing	(long beep)	Incorrect entry or wrong personal code, wait 2 min before trying again.

Information messages

—	(5 beeps)	Start-up in progress
1 flashing	(2 beeps/10 s)	Charging in progress
2 on (SM)	(1 beep/60 s)	Night mode
2 flashing	(2 beep/10 s)	Mower has run for set number of hours
—	(1 beep/10 s)	Normal operations

<i>Command</i>	<i>Function</i>	<i>Setting range</i>
----------------	-----------------	----------------------

Entry commands

* 1 # x # (SM)	Sound level night signal	(x = 0-4, 0 = off)
* 2 # x #	Sound level working signal	(x = 0-4, 0 = off)
* 3 # x #	Sound level fault signal	(x = 0-4, 0 = off)
* 4 # x #	Sound level start-up	(x = 0-4, 0 = off)
* 5 # x #	Installation mode (seek loop)	(x = 1 = on, 0 = off)
* 6 # x # * code #	Personal code valid for x weeks	(x = 1-26 weeks)
* 7 # x # * code #	Theft alarm on/off	(x = 1-1000 minutes on, 0 = off)
* 8 # x # (SM)	Working time limit	(x = 1-10 h; 10 = unlimited.)
* 9 # * code # (00)	Quick setting	
* 19 # x #	Demo mode	
* 20 #	Display fault signal again (98-99: latest fault or information signal)	
* 21 #	Reset all settings to defaults	
* 31 # (AM)	Go and recharge	
* 32 # (AM)	Force mower to mow (delay recharging for 90 minutes [2.2 Ah consumption])	
* 33 # (AM)	Mow secondary area/fully charged	
* 34 # (AM)	Deactivate "Mowing secondary area"	
* 40 # 1-8	Display personal code	
* 50 # hhmm # (AM)	Set clock (24 h system)	
* 51 # hh # (AM)	Start time 1	
* 52 # hh # (AM)	Stop time 1	
* 53 # hh # (AM00)	Start time 2	
* 54 # hh # (AM00)	Stop time 2	
* 55 # cm #	Drive further over loop wire	(cm 0-39 cm <u>further</u> over loop)
* 65 # x # (AM00)	Charging station exit angle 1	(x 0 45 ^a - 315 ^a)
* 66 # x # (AM00)	Charging station exit angle 2	(x 0 45 ^a - 315 ^a)
* 67 # x # (AM00)	Set symmetrical exit angles	(x = 1 = On, 0 = off)
* 69 # x # (AM00)	Activate automatic battery reconditioning	(x = 1 = On, 0 = off)
* 70 # (00)	Test mode	
* 71 # (AM00)	Battery reconditioning	
* 72 # (AM00)	Battery test	
* 99 #	Exit test mode or battery test	
* xxxx #	Enter personal code	
* current code # new # new #	Change code	

AM=Auto Mower SM=Solar Mower

14. Differences between different year models

Certain differences in year models are only described in the relevant previous chapters. The differences compared to model 2000 are described below.

14.1. Differences on 1999 model mowers

14.1.1. The most important changes in the control software or functions:

- Impaired performance in high temperatures. The mower can then give the alarm “cannot find the charging station”
- Only one timer period per day.
- Synchronisation of the charging stations requires a supplement with conversion kit 535 08 21-01.
- Mowers are not suitable for operations with synchronised areas if the area lies on the same lawn. Boundary wires must be placed so far away from each other that there will be several decimetres of uncut grass between the areas.
- Two mowers cannot share one charging station.
- The exit angle from the charging station cannot be set.
- The battery test function is not built-in.
- Trouble shooting via the keyboard is not possible.
- The charging station’s circuit board has simpler damp protection.
- The entire front wheel suspension has a lighter design with among others 4 mm wheel axles instead of 5 mm.

14.1.3 Run straight over sloping areas

The command sequence * 13870 # 204 # 3 # 206 # 20 #, which makes the mower run straighter when it crosses sloping areas, must be programmed manually.

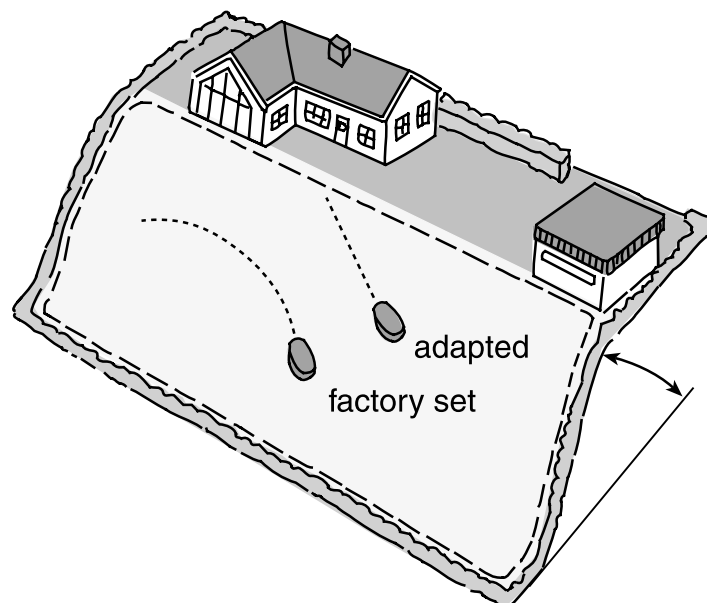

There is a side-effect to this modified setting, however. The mower will have a slight swaying motion when mowing over surfaces that give very little rolling resistance, such as very close-trimmed lawn or a hard surface such as paving. This change is recommended however if the customer has a sloping plot. Otherwise the upper end of lawn may be less well cut, since the mower tends to roll down it. The default setting can be restored by entering the command * 13870 # 204 # 5 # 206 # 70 #, * 21 # or disconnecting the battery.

14.1.4 Working on the mower

No tilt sensor. Special care must therefore be taken when working on a mower that is upside down. Note that if the mower is turned upside down, e.g. during servicing or when cleaning it outside of the boundary wire it believes it is in area A. This phenomenon only applies up to 10 m from the boundary wire. With greater distances the signal is too weak that the mower will not accept it. It is therefore important that the ON/STOP switch is in the STOP position when working under the mower. See figure 16.

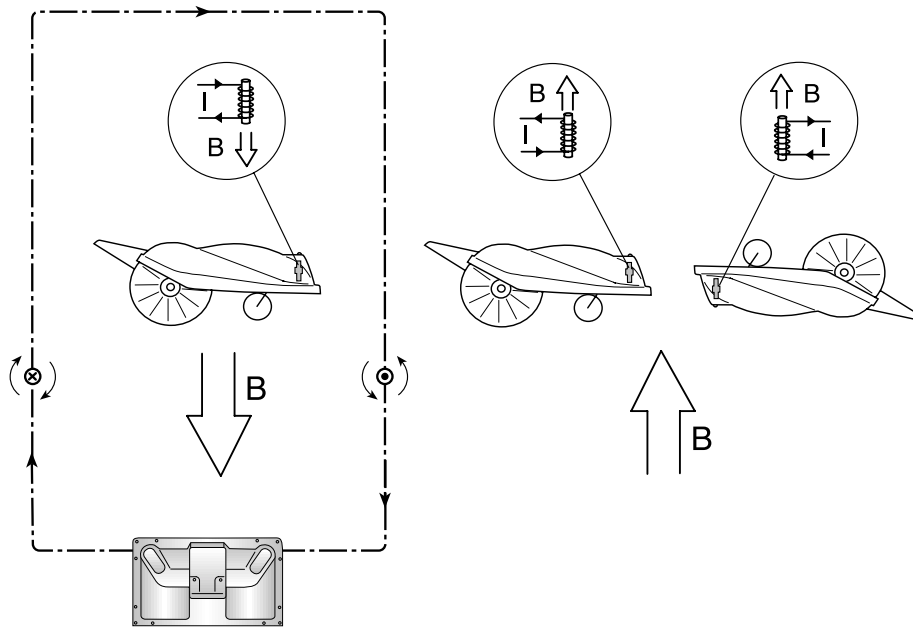

Figure 16. The mower and magnetic field directions

14. 2. Differences on 1998 model mowers

14.2.1. Changes to the control software and functions, besides those mentioned for 1999 models

- Demo mode does not include docking and undocking at 4 minute intervals.
- The functions “mow secondary area”, commands * 33 # and * 34 # are not available
- Default setting for audible error and operating signals is set at volume level 2
- Information message “Starting up” is available
- Information message “Normal mode” is available
- If the theft alarm has been activated you only have one attempt to switch it off using the four digit code’s first digit. Before the alarm starts you have three attempts.

14.2.2. Mechanical differences on 1998 model

- The transformer for the Auto Mower is equipped with a fuse (250 V/2.5 A slow) instead of an automatic cut-out. **NOTE! The mower must not be docked with the charging station the first time with the ON/STOP switch set to ON. If this happens the initial surge of current through the transformer could blow the fuse.**
- Rotating skid plate is not fitted. This means that the cutting disc can become jammed more easily when working on wet grass. There is however an upgrade kit for fitting a rotating scraper to the Solar Mower and Auto Mower. The article number of the kit is 535 08 23-01.
- The Solar Mower’s battery is fitted with a standard socket (for 5.5/2.1 mm plug) for external charging.

14.2.3. Mowing a secondary area with 1998 model

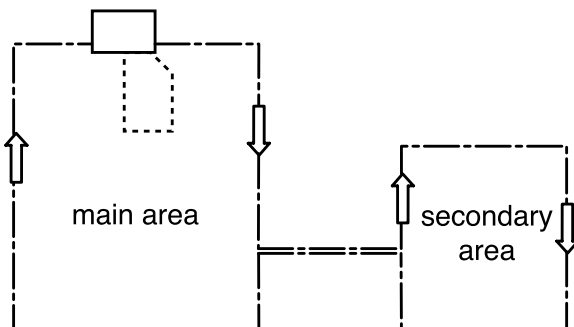

If a single charging station is installed in just one area it will be necessary to do the following: To make sure that the Auto Mower recharges fully you must watch it when it leaves the charging station and then move it or switch it off. When it is placed in the area without a charging station it will mow for 60-90 minutes, depending on the coarseness of the grass, before starting to look for the charging station. In this mode you can force it to run for another 60-90 minutes by entering the command *32#. If it is working hard and the battery is almost drained it may stop before this time has expired because the battery is discharged. It will then give the fault message “cannot find charging station”. If, however, it is placed back in the main area with sufficient charge left in the battery it will go and recharge, then continue mowing the main area as usual.

14.3. Upgrading to model 2000

The following kits are available to upgrade Auto Mower and Solar Mower model –98 to 2000 with regard to the control box and software:

Mower	Auto Mower	Solar Mower
Kit number	535 09 21-01	535 09 23-01
Control box	535 08 01-02	535 08 00-02
Keyboard	535 08 37-01	
LED decals	535 07 51-01, 535 07 65-01	

15. Service aids

The service software Rmtest or Rmtest_lite has been developed to facilitate trouble shooting and measurements on the mowers. A service cable is used to connect to the service socket on the circuit board. By providing direct access to the mower’s electrical system it allows you to measure currents, voltages and the operation of various components. With the program installed on a PC you can carry out automatic or manual tests on the mowers. It is also possible to record values as the mower is working, save them as a file and evaluate them later.

The program also has a function for retrieving a forgotten code. For the 1995 model you use the last four figures of the serial number, and for the others you work from a series of figures that can be read using the keyboard and LEDs. See chapter 4.1 “finding a forgotten code”.

This program also allows you to change a number of the mower’s parameters that control its behaviour and operation. The mower’s microprocessor can be reprogrammed and new control software can be installed without the need of replacing the control box.

The service software is available in two versions, a full version Rmtest and a dealer version Rmtest_lite. The latter lacks the possibility of reading forgotten codes, changing parameters and reprogramming the microprocessor and communication with the battery tester.

The service software Rmtest_lite is available on the CD 535 09 28-01, together with all documentation for the automatic mowers.



2000W23