

# **Operator's manual**

# **P524**



Please read the operator's manual carefully and make sure you understand the instructions before using the machine.

**English**

# CONTENTS

## Contents

### CONTENTS

Contents .....	2
<b>Service journal</b>	
Pre-delivery service .....	3
After the first 25 hours .....	3
<b>INTRODUCTION</b>	
Dear Customer, .....	4
Driving and transport on public roads .....	4
Towing .....	4
Use .....	4
Good service .....	4
<b>KEY TO SYMBOLS</b>	
Symbols .....	5
Explanation of warning levels .....	6
<b>WHAT IS WHAT?</b>	
Location of the controls .....	7
<b>SAFETY INSTRUCTIONS</b>	
Safety instructions .....	8
Driving on slopes .....	9
Children .....	10
Maintenance .....	10
Transport .....	11
<b>PRESENTATION</b>	
Presentation .....	12
Throttle trigger .....	12
Choke control .....	12
Speed limiter .....	12
Counter .....	12
Parking brake .....	12
ROPS (Roll Over Protective Structure) .....	13
Safety belt .....	13
Cutting unit .....	13
Lever for hydraulic lift of attachments .....	13
Cutting height adjustment lever .....	14
Seat .....	14
Fueling .....	15
Lights and power outlet .....	15
Bypass valves .....	15
<b>STARTING ENGINE</b>	
Before starting .....	16
Start the engine .....	16
Starting the engine with a weak battery .....	17
<b>DRIVING</b>	
Driving the Rider .....	18
Braking .....	18
Stop the engine .....	18
<b>Maintenance</b>	
Maintenance schedule .....	19
Cleaning .....	21
Removing of the machine hoods .....	21
Adjusting the parking brake .....	22
Checking the throttle wire .....	22
Checking the choke wire .....	22
Replacement of fuel filter .....	22
Checking the fuel pump's air filter .....	22

Replacing the air filter .....	23
Ignition system .....	23
Cleaning the engine and muffler .....	24
Check the safety system .....	24
Replacing the light bulbs .....	24
Main fuse .....	24
Checking the tyre pressure .....	25
Checking the engine's cooling air intake .....	25
Replacing the cutting belt .....	25
Fitting the cutting head .....	27
Removing the cutting unit .....	27
Service position for the cutting unit .....	27
Checking and adjustment of the cutting unit's ground pressure .....	28
Checking the cutting unit's parallelism .....	28
Adjusting the parallelism of the cutting unit .....	29
Replacing the cutting unit belts .....	29
Checking the blades .....	30
Replacing the blades .....	30
Removing the BioClip plug .....	30
Check the hydraulic system oil level .....	30
Hydraulic oil filter change .....	30
Check the oil level in the transmission .....	31
Checking the engine's oil level. ....	31
Changing the oil filter .....	32
<b>Lubrication</b>	
Lubrication schedule .....	33
General .....	34
Accessories .....	35
Lubricating the cables .....	35
Cutting unit .....	35
Pedal system in the frame tunnel .....	35
Parking brake cable .....	35
Chains in the frame tunnel .....	35
Links and joints in the cutting adjustment .....	36
Driver seat .....	36
Throttle and choke cables, lever bearings .....	36
Lubricate the hydrostatic cable with links .....	36
Steering cylinder .....	36
Joint bearing .....	36
Link brace .....	36
<b>Troubleshooting schedule</b>	
<b>ELECTRICAL AND HYDRAULIC SYSTEMS</b>	
Electrical system .....	38
Hydraulic System .....	39
<b>Storage</b>	
Winter storage .....	40
Guard .....	40
Service .....	40
<b>Technical data</b>	
Dimensions .....	43
EC Declaration of Conformity .....	44

# Service journal

## Pre-delivery service

- 1 Charge the battery for at least 4 hours at max. 3 amp.
- 2 Check and adjust the air pressure in the tyres (100 kPa, 1.0 bar, 14.5 PSI).
- 3 Adjust cutting unit:
  - Adjust lift springs (effective weight of cutting unit should be 12-15kg / 26.5-33 lb).
  - Adjust cutting unit so that rear edge is about 2-4 mm / 1/8" higher than front edge.
  - Adjust cutting unit height setting so that cutting height limit is 5 mm / 3/16" above the frame of the unit at the lowest cutting height.
- 4 Check that the right amount of oil is in the engine.
- 5 Check that there is oil in the transmission's oil tank.
- 6 Connect battery.
- 7 Fill with fuel and start engine.
- 8 Check that machine does not move in neutral.
- 9 Check:
  - Forward drive.
  - Reverse drive.
  - Operation of blades.
  - Seat safety switch.
  - Lif lever safety switch.
  - Safety switch. For the hydrostat pedals.
- 10 Check the oil level in the hydraulic system. Top up if necessary.

## 11 Tell customer about:

The requirement and advantages of servicing the machine according to the service plan

Servicing and the influence of this journal on the second-hand value of the machine.

The transmission warranty is only valid if front and rear wheel rotation speed has been checked in accordance with the service schedule. Adjust if necessary according to the table values specified in the workshop manual. Performed by authorized servicing dealer. The system will be damaged if this adjustment is not carried out.

At temperatures below 0 ° C, the machine must be warmed up for at least 10 minutes for the hydraulic oil and transmission to get hot. Otherwise there is a risk of the transmission breaking down thereby reducing the service life of the transmission.

Servicing and the influence of this journal on the second-hand value of the machine.

Range of applications for BioClip function.

Complete proof of sale etc.

Pre-delivery service carried out. No outstanding problems.  
Certified:

Date:
Mileage:
Signature:
Label:

## After the first 25 hours

- 1 Change the engine oil.
- 2 Changing the gearbox oil (Only AWD-machines)
- 3 Check front and rear wheel rotation speed according to the service schedule. (Only AWD-machines) See the workshop manual.

---

# INTRODUCTION

---

## Dear Customer,

Thank you for choosing a Husqvarna Rider. Husqvarna Riders are built to a unique design with a front-mounted cutting unit and a patented articulated steering. Riders are designed for maximum efficiency even in small or confined areas. The closely grouped controls and pedal-operated hydrostatic transmission also contribute to the performance of this machine.

This operator's manual is a valuable document. By following its instructions (on operation, service, maintenance, etc.) you will significantly extend the life of the machine and even its second-hand value.

When you sell your Rider, make sure you pass on the operator's manual to the new owner.

The last chapter in the operator's manual consists of a Service Journal. Make sure that all service work and repairs are recorded. A well-documented service history reduces the costs of seasonal maintenance and influences the second-hand value of the machine. Bring the operator's manual with the Rider when bringing it to a workshop for service procedures.

## Driving and transport on public roads

Check the relevant road traffic regulations before driving the machine on a public road. If transporting the machine on another vehicle always use approved securing devices and make sure that the machine is securely held.

## Towing

When your machine is equipped with a hydrostatic transmission you should only tow the machine over short distances and at a low speed, otherwise there is a risk of damaging the transmission.

The transmission must be disengaged when towing, see instructions under the heading Bypass valves.

## Use

This ride-on mower is designed to mow grass on open and level ground surfaces. In addition, there is a number of accessories recommended by the manufacturer that broadens the application area. Please contact your dealer for more information about which accessories are available. The machine may only be used with the equipment recommended by the manufacturer. All other types of use are incorrect. Compliance with and strict adherence to the conditions of operation, service and repair as specified by the manufacturer also constitute essential elements of the intended use.

**IMPORTANT!** The transmission warranty is only valid if front and rear wheel rotation speed has been checked in accordance with the service schedule. Adjust if necessary according to the table values specified in the workshop manual. Performed by authorized servicing dealer. The system will be damaged if this adjustment is not carried out. (Only AWD-machines)

This machine should be operated, serviced and repaired only by persons who are familiar with its particular characteristics and who are acquainted with the relevant safety procedures.

Accident prevention regulations, all other generally recognised regulations on safety and occupational medicine, and all road traffic regulations must be observed at all times.

Any arbitrary modifications carried out to this machine may relieve the manufacturer of liability for any resulting damage or injury.

## Good service

Husqvarna products are sold all over the world and ensures that you, the customer, get the best support and service. For example, before this machine was delivered it was inspected and adjusted by your dealer. See the certificate in the Service Journal in this manual.

When you need spare parts or advice on service issues, warranty terms, etc., contact:

This Operator's Manual belongs to machine with serial number:	Engine	Transmission

On the machine's rating plate you will find the following information:

- The machine's type designation.
- The manufacturer's type number.
- The machine's serial number.

State the type designation and serial number when ordering spare parts.

# KEY TO SYMBOLS

## Symbols

These symbols are on the machine and in the instructions. **Other symbols/decals on the machine refer to special certification requirements for certain markets.**

**WARNING!** Careless or incorrect use can result in serious or fatal injury to the operator or others.



Please read the operator's manual carefully and make sure you understand the instructions before using the machine.



This product is in accordance with applicable EC directives.



Fast



Slow



Stop the engine.



Choke.



Fuel



Oil level



Cutting height



Backwards



Forwards



Ignition



Parking brake



Noise emission to the environment according to the European Community's Directive. The machine's emission is specified in the Technical data chapter and on the label.



Clutch in



Clutch out



Warning: rotating parts. Keep hands and feet clear.



Rotary blades Keep hands and feet away from under the hood when the engine is running



Never drive across a slope



Never use the machine if persons, especially children, or animals, are in the vicinity



Never carry passengers on the machine or equipment



Drive very slowly if no cutting unit is fitted



Brake

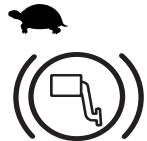

Switch off the engine and take off the ignition cable before repairs or maintenance



Check the engine's oil level

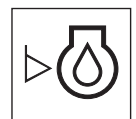

Check transmission oil level

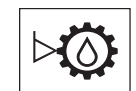

---

# KEY TO SYMBOLS

---

## Explanation of warning levels

The warnings are graded in three levels.

### WARNING!



**WARNING!** Used if there is a risk of serious injury or death for the operator or damage to the surroundings if the instructions in the manual are not followed.

### IMPORTANT!

**IMPORTANT!** Used if there is a risk of injury to the operator or damage to the surroundings if the instructions in the manual are not followed.

### CAUTION!

**CAUTION!** Used if there is a risk of damage to materials or the machine if the instructions in the manual are not followed.

# WHAT IS WHAT?

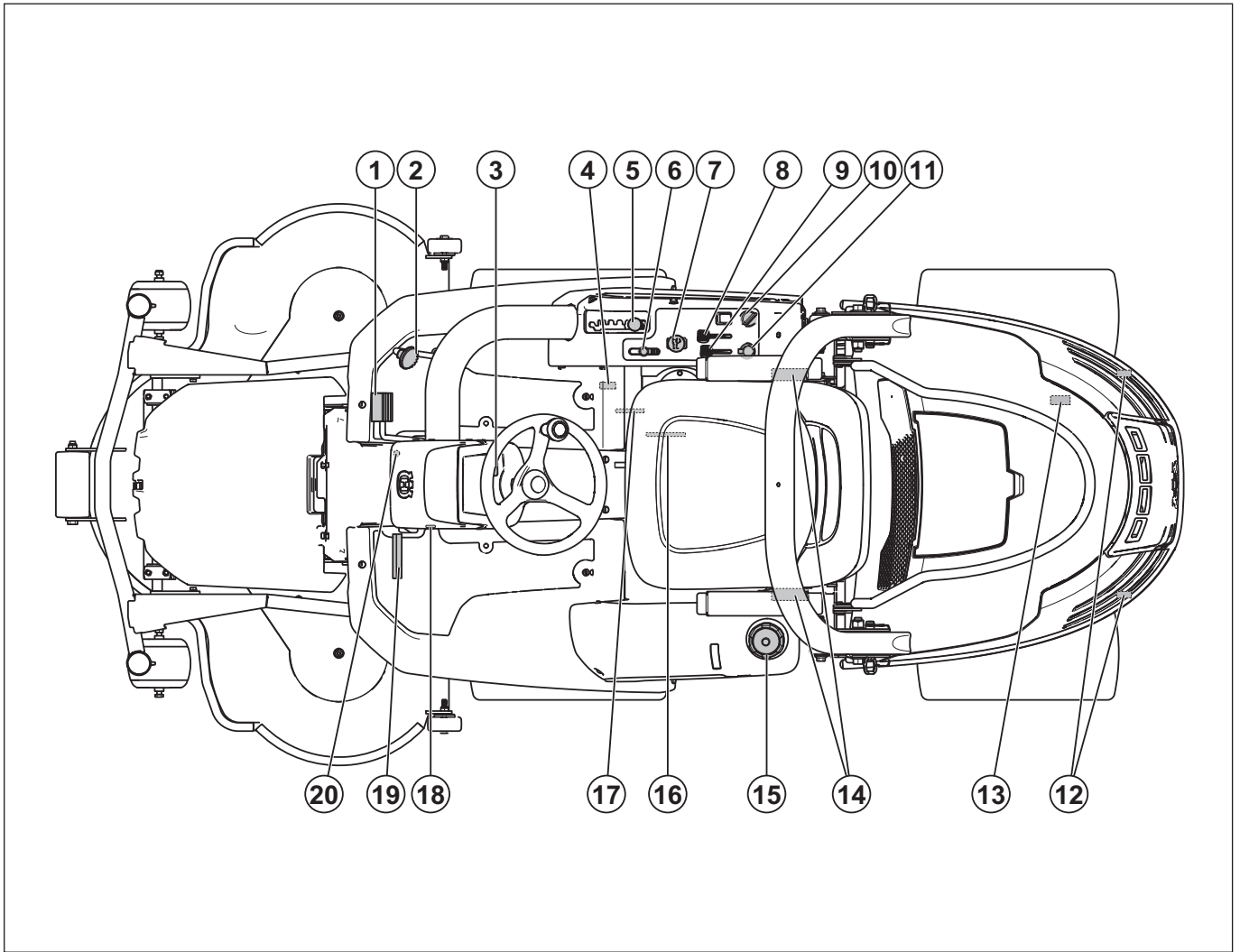

## Location of the controls

- |   |                                    |
|---|------------------------------------|
| 1 Speed limiter pedal forwards            | 11 Power outlet                    |
| 2 Speed limiter pedal reverse             | 12 Cover lock                      |
| 3 Switch for the lights                   | 13 Bypass valve rear axle          |
| 4 Bypass valve front axle                 | 14 Safety belt                     |
| 5 Cutting height adjustment lever         | 15 Fuel cap                        |
| 6 Lever for hydraulic lift of attachments | 16 Seat adjustment                 |
| 7 PTO button.                             | 17 Product and serial number plate |
| 8 Throttle trigger                        | 18 Counter                         |
| 9 Choke control                           | 19 Parking brake                   |
| 10 Ignition lock                          | 20 Lock button for parking brake   |

# SAFETY INSTRUCTIONS

## Safety instructions

These instructions are for your safety. Read them carefully.

### Insure your Rider

- Check the insurance coverage for your new Rider.
- Contact your insurance company.
- You should have fully comprehensive insurance including: third party, fire, damage, theft and liability

### General use

- Read all the instructions in this operator's manual and on the machine before you start it. Ensure you understand them and then observe them.



**WARNING!** This machine produces an electromagnetic field during operation. This field may under some circumstances interfere with active or passive medical implants. To reduce the risk of serious or fatal injury, we recommend persons with medical implants to consult their physician and the medical implant manufacturer before operating this machine.

- Learn how to use the machine and its controls safely and learn to how to stop quickly. Also learn to recognize the safety decals.
- Only allow the machine to be used by adults who are familiar with its use.
- Make sure nobody else is in the vicinity of the machine when you start the engine, engage the drive or drive off.
- Clear the area of objects such as stones, toys, wires, etc. that may become caught in the blades and be thrown out.



- Look out for the ejector and do not direct it towards anyone.
- Stop the engine and prevent it from starting before you clean the cutting unit.

- Remember that the driver is responsible for dangers or accidents.
- Never carry passengers. The machine is only intended to be used by one person.



- Always look downwards and backwards before and while reversing. Keep watch for both large and small obstacles.
- Slow before cornering.
- Switch off the blades when you are not mowing.
- Take care when rounding a fixed object, so that the blades do not hit it. Never run the machine over foreign objects.



**WARNING!** This machine can sever hands and feet as well as throw objects. Failure to observe the safety instructions can result in serious injuries.



**WARNING!** The inside of the muffler contain chemicals that may be carcinogenic. Avoid contact with these elements in the event of a damaged muffler.



**WARNING!** The engine emits carbon monoxide, which is a colourless, poisonous gas. Do not use the machine in enclosed spaces.

- Only use the machine in daylight or in other well-lit conditions. Keep the machine at a safe distance from holes or other irregularities in the ground. Pay attention to other possible risks.
- Never use the machine if you are tired, if you have consumed alcohol, if you are taking other drugs or medication that can affect your vision, judgement or coordination.
- Never use the machine in bad weather, for instance in fog, in rain, damp or in wet locations, strong winds, intense cold, risk of lightning, etc.
- Keep an eye on the traffic when working close to a road or when crossing it.
- Never leave the machine unsupervised with the engine running. Always stop the blades, apply the parking brake, stop the engine and remove the keys before leaving the machine.



# SAFETY INSTRUCTIONS

- Never allow children or other persons not trained in the use of the machine to use or service it. Local laws may regulate the age of the user.



**WARNING!** You must use approved personal protective equipment whenever you use the machine. Personal protective equipment cannot eliminate the risk of injury but it will reduce the degree of injury if an accident does happen. Ask your dealer for help in choosing the right equipment.

- Use hearing protection to minimise the risk of hearing impairment.



- Never wear loose-fitting clothing, jewellery or similar that can get caught in moving parts.
- Never use the machine when barefoot. Always wear protective shoes or protective boots, preferably with steel toes.



- Make sure that you have first aid equipment close at hand when using the machine.



## Driving on slopes

Driving on slopes is one of the operations where the risk of the driver losing control of the machine or of it overturning is the greatest; this can result in serious injury or death. All slopes demand extra care. If you cannot reverse up a slope or if you feel unsure, do not mow it.

### IMPORTANT!

Do not drive down slopes with the cutting deck raised.

## This is what you do

- Remove obstacles such as stones, branches, etc.
- Mow upwards and downwards, not sideways.

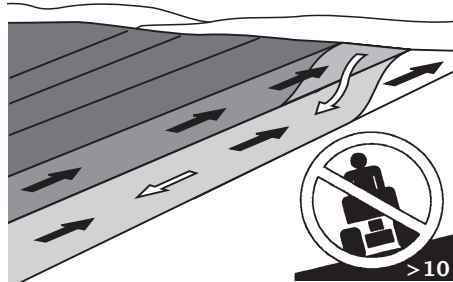

- Do not use the machine on ground that slopes more than 10°.
- Take extra care if any attachments are fitted that can change the stability of the machine.
- Avoid starting or stopping on a slope. If the tyres start to slip, stop the blades and drive slowly down the slope.
- Always drive smoothly and slowly on slopes.
- Do not make any sudden changes in speed or direction.
- Avoid unnecessary turns on slopes, if necessary, turn slowly and gradually downwards if possible. Drive slowly. Do not turn the wheel sharply.
- Watch out for and avoid driving over furrows, holes and bumps. It is easier for the machine to overturn on uneven ground. Tall grass can hide obstacles.

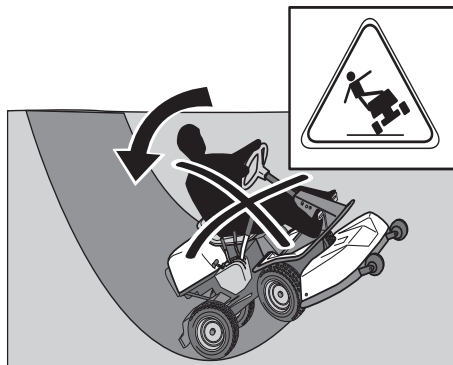

- Do not mow too close to edges, ditches or banks. The machine can suddenly overturn if one wheel comes over the edge of a steep slope or a ditch, or if an edge gives way.
- Do not mow wet grass. It is slippery, and tyres can lose their grip so that the machine skids.
- Do not try to stabilize the machine by putting your foot on the ground.
- When cleaning the chassis, the machine may never be driven near verges or ditches.
- When mowing, keep away from bushes and other objects.

# SAFETY INSTRUCTIONS

- Follow the manufacturer's recommendations regarding wheel weights or counterbalance weights to increase machine stability.

## IMPORTANT!

Wheel weights fitted on the rear wheels are recommended when driving on slopes for safer steering and improved manoeuvrability. Consult your dealer concerning the use of wheel weights if you are unsure. Wheel weights can not be used on AWD-machines. Use counterweights.

## Children

- Serious accidents may occur if you fail to be on your guard for children in the vicinity of the machine. Children are often attracted to the machine and mowing. Never assume that children will remain where you last saw them.
- Keep children away from the area to be mowed and under close supervision by another adult.
- Keep an eye out and shut off the machine if children enter the work area.
- Before and during reversing procedures, look behind you and down for small children.
- Never allow children to ride along. They can fall off and seriously injure themselves or be in the way for safe maneuvering of the machine.
- Never allow children to operate the machine.

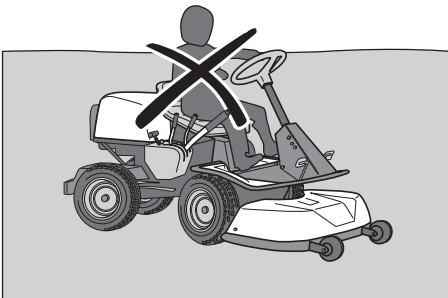

- Be particularly careful near corners, bushes, trees or other objects that block your view.

## Maintenance

- Stop the engine. Prevent the engine from starting by removing the ignition key before making any adjustments or performing maintenance.
- Never fill the fuel tank indoors.



- Fuel and fuel vapour are poisonous and highly flammable. Be especially careful when handling petrol and engine oil, as carelessness can result in personal injury or fire.
- Only store fuel in containers approved for the purpose.
- Never remove the fuel cap and fill the fuel tank when the engine is running.
- Allow the engine to cool before refuelling. Do not smoke. Do not fill with fuel in the vicinity of sparks or naked flames.
- Handle oil, oil filters, fuel and the battery carefully, of environmental considerations. Follow the local recycling requirements.
- Electrical shocks can cause injuries. Do not touch cables when the engine is running. Do not test the ignition system with your fingers.



**WARNING! The engine and the exhaust system become very hot during operation. Risk of burn injuries if touched. When mowing, keep away from bushes and other materials in order to avoid a heating effect.**

- If leaks arise in the fuel system, the engine must not be started until the problem has been resolved.
- Store the machine and fuel in such a way that there is no risk that leaking fuel or fumes can cause any damage.
- Check the fuel level before each use and leave space for the fuel to expand, because the heat from the engine and the sun may otherwise cause the fuel to expand and overflow.
- Avoid overfilling. If you spill petrol on the machine, wipe up the spill and wait until it has evaporated before starting the engine. If you spill on your clothing, change your clothing.
- Allow the machine to cool before performing any actions in the engine compartment.
- Take care with battery maintenance. Explosive gases form in the battery. Never perform maintenance on the battery while smoking or in the vicinity of open flames or sparks. This can cause the battery to explode and cause serious injuries.

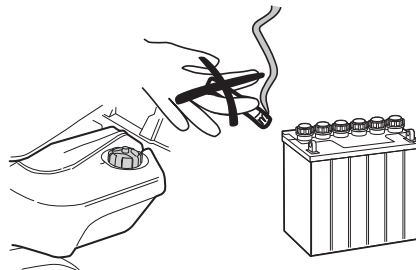

- Make sure all nuts and bolts are tightened correctly and that the equipment is in good condition.
- Do not modify safety equipment. Check regularly to be sure it works properly. The machine must not be driven if protective plates, protective covers, safety switches or other protective devices are not fitted or are defective.
- Observe the risk of injury caused by moving or hot parts if the engine is started with the engine cover open or protective cowlings removed.

# SAFETY INSTRUCTIONS

- Do not change the setting of governors. If you run too fast, you risk damaging the machine components. See chapter on Technical data for highest permitted engine speed.
- Never use the machine indoors or in spaces lacking proper ventilation. Exhaust fumes contain carbon monoxide, an odourless, poisonous and highly dangerous gas.

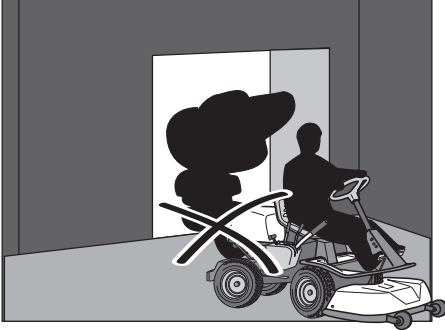

- Stop and inspect the equipment if you run over or into anything. If necessary, make repairs before starting.
- Never make adjustments with the engine running.
- The machine is tested and approved only with the equipment originally provided or recommended by the manufacturer.
- The blades are sharp and can cause cuts. Wrap the blades or wear protective gloves when handling them.
- Check regularly that the parking brake works. Adjust and maintain as required.
- Reduce the risk of fire by removing grass, leaves and other debris that may have fastened on the machine. Allow the machine to cool before putting it in storage.

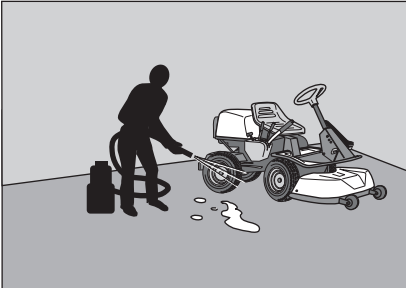

## Transport

### CAUTION!

The parking brake is not sufficient to lock the machine during transport. Ensure you secure the machine firmly to the transporting vehicle.

- The machine is heavy and can cause serious crush injuries. Take extra care when loading it onto or off a vehicle or trailer.
- Use an approved trailer to transport the machine.
- To secure the machine on the trailer, two approved tension belts and four wedge shaped wheel blocks should be used.

Engage the parking brake and tie the tension belts around stable parts on the machine, e.g. frame or rear wagon. Secure the machine by tensioning the belts towards the back and the front of the trailer respectively.

Place the wheel blocks in front of and behind the rear wheels.

- Check and observe local road traffic regulations before transporting or driving the machine on roads.

# PRESENTATION

## Presentation

Congratulations on your choice of an excellent quality product that will give you great pleasure for many years. This operator's manual describes P524. The machine is equipped with a four-stroke V-Twin engine from Kawasaki.

The machine is equipped with power steering and hydraulic lifts.

The machine is equipped with four wheel drive. The power transmission from the engine is handled by a hydrostatic transmission, which allows variable variation of the speed by using the pedals. One pedal for driving forward and one for reverse.

## Throttle trigger

The throttle control regulates the engine speed, and thereby also the rotation speed of the blades.

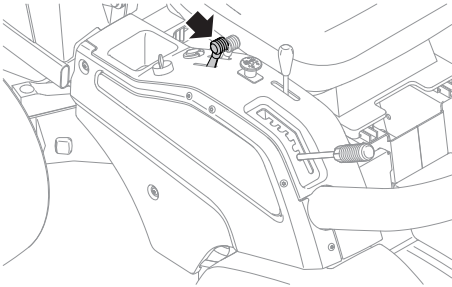

To increase or reduce the engine speed the control is moved backwards or forwards.

Avoid idling the engine for long periods, as there is a risk of carbon build-up on the spark plugs.

## Choke control

The choke lever is used for cold starting and to give the engine a richer fuel mixture.

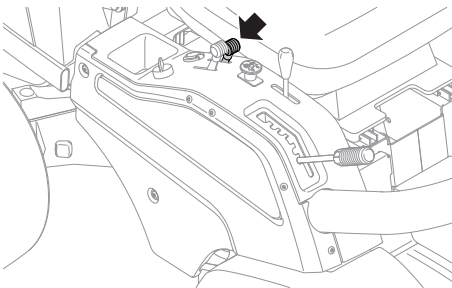

For cold starting the lever is moved backwards to its end position.

**IMPORTANT!** At temperatures below 0 ° C, the machine must be warmed up for at least 10 minutes for the hydraulic oil and transmission to get hot. Otherwise there is a risk of the transmission breaking down thereby reducing the service life of the transmission.

## Speed limiter

The speed of the machine is steplessly regulated with two pedals. Pedal (1) is used to drive forwards, and pedal (2) to drive backwards.

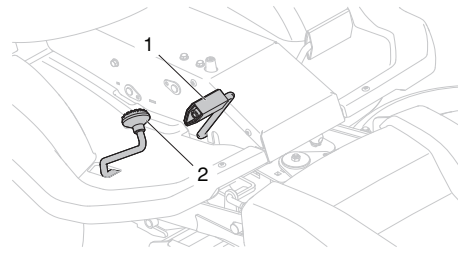

**WARNING!** Make sure that branches do not obstruct the pedals when mowing under bushes. Otherwise there is a risk you may lose control.

## Counter

The chronometer shows how many hours the engine has been running.

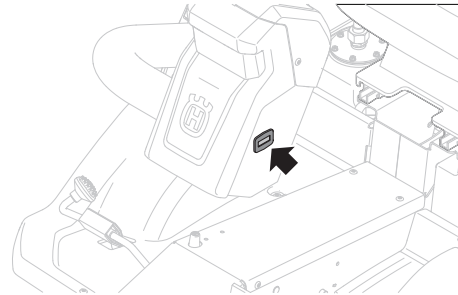

Any time when the engine is not running but the ignition is switched on is not registered. The last digit shows tenths of an hour (6 minutes).

## Parking brake

The parking brake is applied as follows:

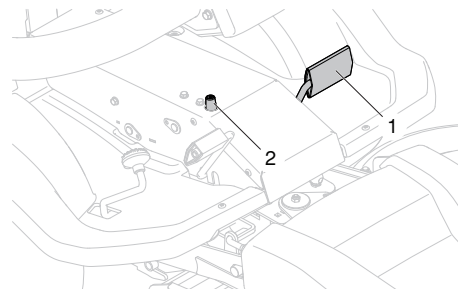

- 1 Press down the parking brake pedal (1).
- 2 Fully depress the lock button (2).
- 3 Release the parking brake pedal while keeping the button pressed in.

# PRESENTATION

## ROPS (Roll Over Protective Structure)

ROPS is a protective frame that reduces the risk of injury in the event of overturning. Use ROPS and a safety belt when driving on slopes.

The frame can be folded down.

- Remove the two pins that hold the frame and fold it backwards.

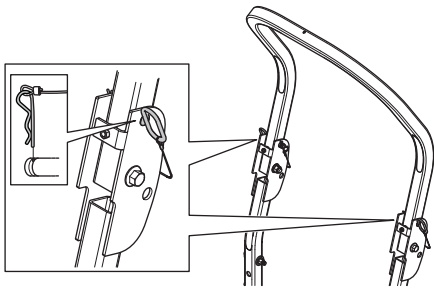

**WARNING!** If the frame is folded down the safety belt should NOT be used.

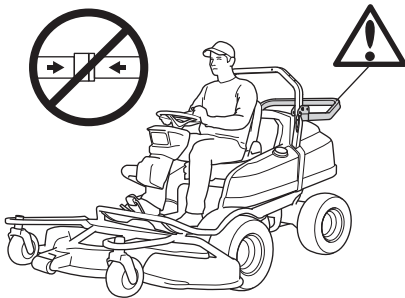

**WARNING!** If the frame is folded up, the safety belt must be used.

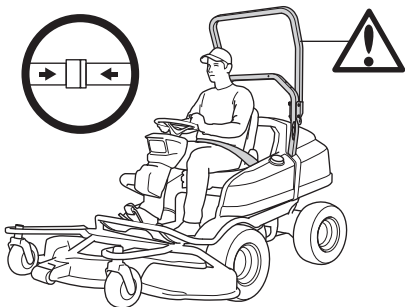

## ROPS check

- Check that the ROPS is securely attached and not damaged.

## Safety belt

The seat belt protects the driver from injury in case of crashes or overturning.

The belt may only be used when the bar (ROPS) has been raised.

## Seat belt check

Check regularly that the seat belt is intact and secured correctly.

## Cutting unit

P524 can be equipped with three different cutting units.

Combi 103, Combi 112 and Combi 122.

The Combi-unit, equipped with a BioClip-plug, finely chops the cuttings to fertiliser. Without the BioClip-plug the unit works in the same way as a rear ejection unit. The rear ejector ejects the clippings behind the unit without finely chopping them.

## Lever for hydraulic lift of attachments

The lifting lever is used to put the cutting unit in either the transport or mowing position when hydraulic pressure is available.

The lever has four different positions.

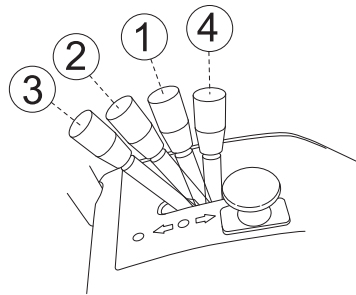

- Position 1 is the neutral position.
- Position 2 lowers the cutting unit with spring return to the neutral position
- Position 3 is floating where the lever stops. The unit is lowered to the automatically floating position, which means that the cutting unit follows the contours of the ground.
- Position 4 raises the cutting unit with spring return to neutral position.

When cutting the lever should be set directly to the floating position (3).

## Lifting the Cutting Unit (Transport Position)

Turn off the cutting unit using the PTO button.

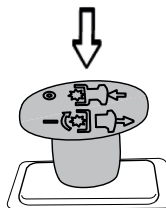

# PRESENTATION

Pull the lever backwards to engage the transport position.

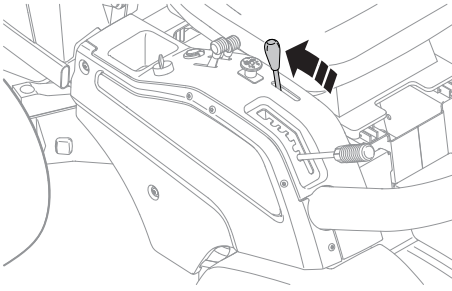

The unit is then raised.

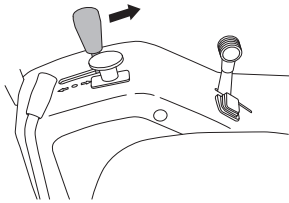

The cutting unit can be raised slightly with the blades rotating. This is to facilitate the mowing of extremely tall grass or uneven surfaces.

## Lowering the Unit (Mowing Position)

Move the hydraulic lifting lever forwards to engage the cutting position. This lowers the cutting unit.

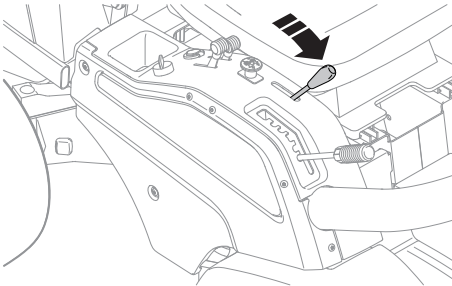

When cutting the lever should be set directly to the floating position (3).

## Controls for operating the cutting unit blades (PTO button)

The cutting unit can be started only when the driver is sitting in the seat.

- Pull out the lever to engage the drive of the blades.

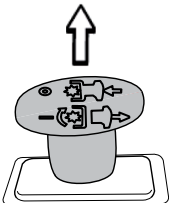

- Push in the lever to disengage the blades.

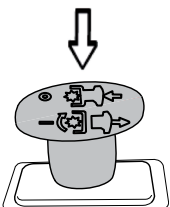

When the safety circuit has stopped the drive to the cutting unit, the control must be pushed and pulled out again to start the blades.

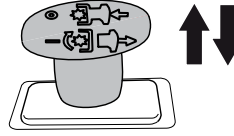

The safety circuit is triggered and the cutting unit is stopped in the following cases:

- When the driver leaves the seat with the blades engaged. There is a short delay to prevent stopping if the driver bounces on the seat.

## Cutting height adjustment lever

The cutting height can be adjusted to 6 different positions with the cutting height lever.

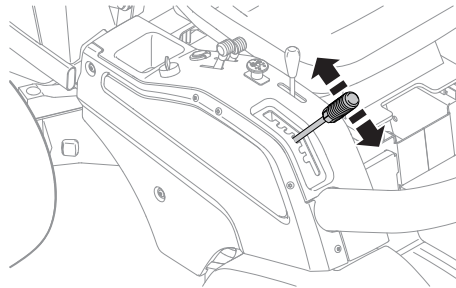

## Seat

The seat has a jointed attachment on the front edge and can be tipped forward.



**WARNING! Do not adjust seat settings while driving. Risk of unsafe manoeuvring.**

The seat can also be adjusted lengthways.

- To adjust move the lever under the front edge of the seat to the left, so that the seat can be moved forward or backwards to the required position.

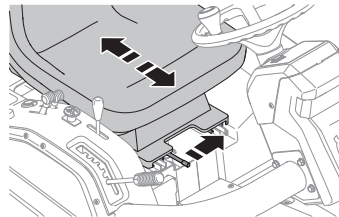

- The seat springing can be adjusted by moving the rubber stops in their mountings on the underside of the seat. Place both stops in the front, middle or rear.

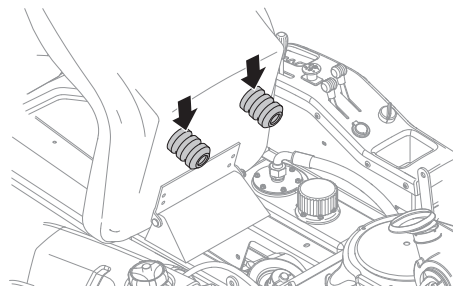

# PRESENTATION

## Fueling

The engine runs on unleaded petrol with a minimum octane rating of 95 (not mixed with oil). We recommend the use of biodegradable alkylate petrol. (max. methanol 5%, max. ethanol 10%, max. MTBE 15%)

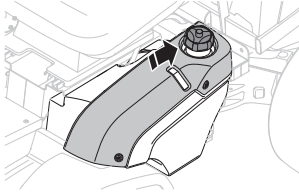

**WARNING! Petrol is highly inflammable. Exercise care and refuel outdoors (see safety instructions).**

If you have spilled fuel on yourself or your clothes, change your clothes. Wash any part of your body that has come in contact with fuel. Use soap and water.

Wipe up any spillage. Materials contaminated by fuel must be moved to a safe location.

**IMPORTANT!**

Do not use the fuel tank as a support area.

## Lights and power outlet

### Lights

The lights are switched on and off using the power switch on the control panel.

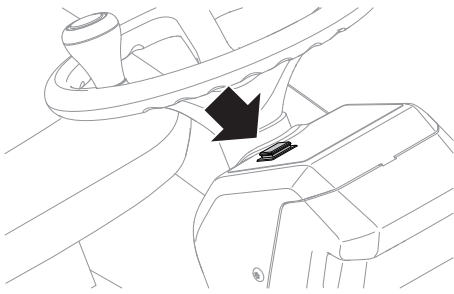

### Power outlet

The power outlet is switched on and off using power switch on the control panel.

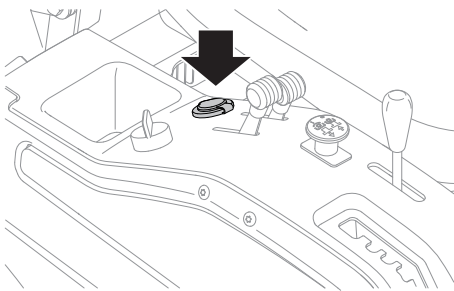

A seat heater or mobile phone charger are examples of articles that can be connected to the power socket.

The voltage is 12 V.

The power outlet is fuse protected by its own fuse. The fuse for the power outlet is placed in the electrical connection box, behind the side plate on the control panel.

## Bypass valves

Hydraulic pressure must be released in order for the ride-on mower to be moved when the engine is shutoff.

The hydraulic pressure is opened and closed with a bypass valve.

If you try to drive the machine without hydraulic pressure, it will not move. The drive on the axle is disengaged if one valve is open.

The P524 has two valves, one valve for the front axle and one for the rear axle.

**IMPORTANT! Always drive the machine with both valves closed.**

### Bypass valve rear axle

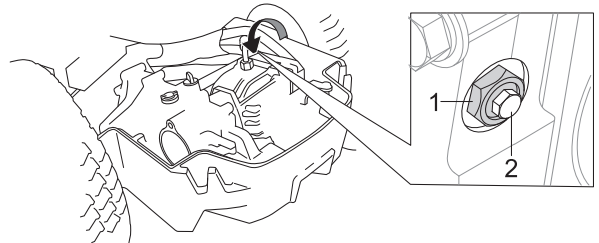

- The hydraulic pressure is released by opening the locking nut (1) 1/4-1/2 turn anti-clockwise, then the bypass valve (2) 2 turns.
- The hydraulic pressure is switched on by closing the valve. Close the valve nut (2) fully before tightening the locking nut (1).

### Bypass valve front axle

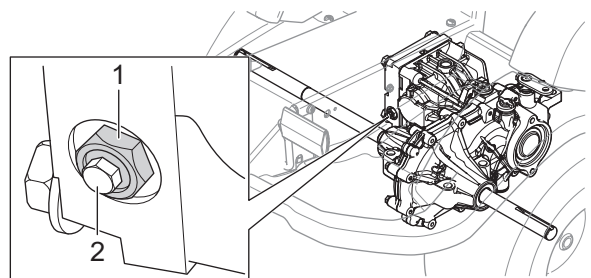

- The hydraulic pressure is released by opening the locking nut (1) 1/4-1/2 turn anti-clockwise, then the bypass valve (2) 2 turns.
- The hydraulic pressure is switched on by closing the valve. Close the valve nut (2) fully before tightening the locking nut (1).

# STARTING ENGINE

## Before starting

- Read the safety instructions and information concerning the placement of controls and functions before starting.
- Perform daily maintenance before starting as set out in the Maintenance schedule.

### IMPORTANT!

The air intake grille in the engine cover must not be blocked by, for example, clothing, leaves, grass or dirt. Impaired cooling of the engine. Risk of major engine damage.

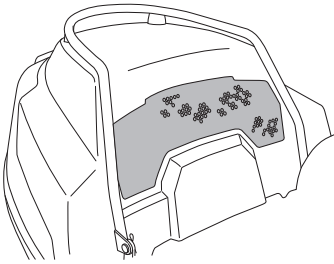

- Localise and mark stones and other fixed objects to avoid collision.
- Start with a high cutting height and reduce down until the required mowing results are obtained.
- The mowing result will be best with the highest permitted engine speed, see technical data, (the blades rotate rapidly) and low speed (the Mower moves slowly). If the grass is not too high and thick, the driving speed can be increased without noticeably depreciating the mowing result.
- The best lawns are achieved if the grass is cut often. Mowing becomes more uniform and the grass cuttings become more evenly distributed over the surface. The total time consumption is not greater since it is possible to select a higher driving speed without inferior mowing results.
- Avoid mowing a wet lawn. The mowing results are inferior since the wheels sink down into the soft lawn.
- Hose down the cutting unit with water underneath each time it is used, avoid using a high pressure washer. The cutting unit should then be put in the service position.
- When the BioClip function is used, it is very important that the mowing interval is not too long.

## Start the engine

- 1 Ensure that the bypass valves are closed.
- 2 Apply the parking brake.

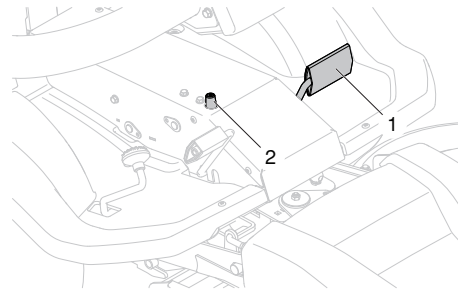

- 3 Push the PTO switch down (blades off).

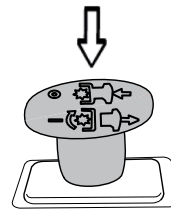

- 4 The engine will not start unless the parking brake is on and the PTO switch is pressed

- 5 Move the throttle control to the middle position.

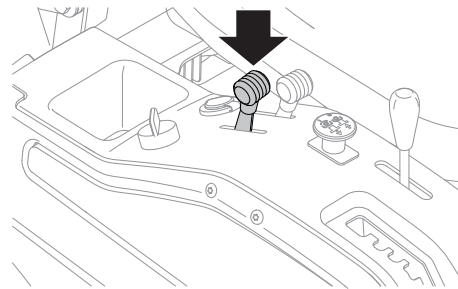

- 6 If the engine is cold move the choke lever backwards to its end position.

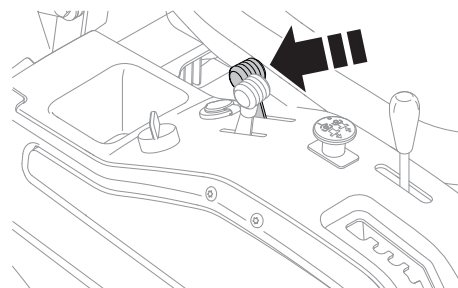

- 7 Turn the ignition key to the start position.

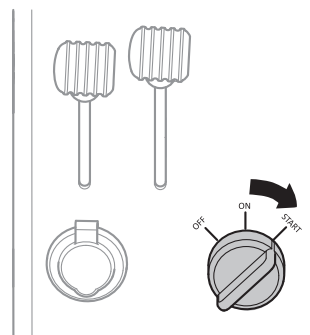



# STARTING ENGINE

- 8 When the engine starts release the ignition key immediately back to neutral position.

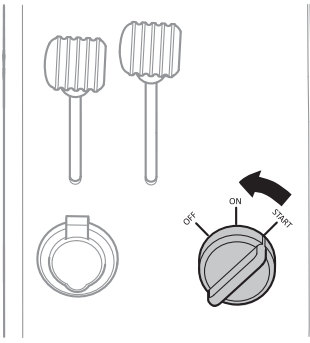

## IMPORTANT!

Do not run the starter for more than about 15 seconds at a time. If the engine does not start, wait about 15 seconds before trying again.

- 9 Push the choke lever gradually forward when the engine has started.

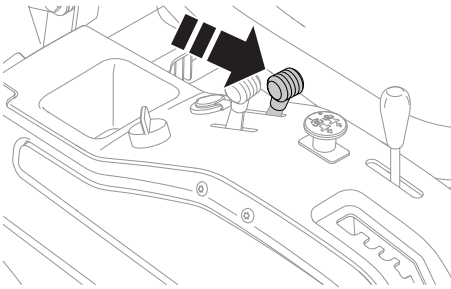

Let the engine run at moderate speed or half throttle for 3-5 minutes before subjecting it to heavy load.

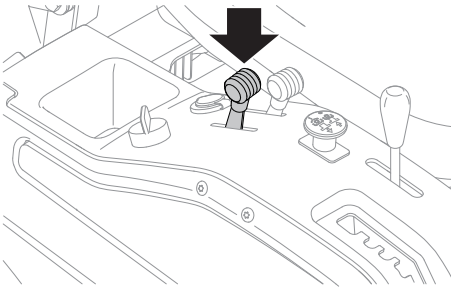

- 10 Set the required engine speed with the throttle control.



**WARNING! Never run the engine indoors, in enclosed or poorly ventilated areas. The exhaust fumes contain toxic carbon monoxide.**

## Starting and driving when cold

If the engine fails to start due to the cold, repeat ignition and attempt to re-start. Start gas or ether must not be used.

**IMPORTANT!** At temperatures below 0 ° C, the machine must be warmed up for at least 10 minutes for the hydraulic oil and transmission to get hot. Otherwise there is a risk of the transmission breaking down thereby reducing the service life of the transmission.

## Starting the engine with a weak battery



**WARNING! Lead-acid batteries produce explosive gases. Avoid sparks, open flames and smoking close to batteries. Always wear protective glasses in the vicinity of batteries.**

If the battery is too weak to start the engine, it should be recharged.

When jump leads are used for emergency starting, follow the procedure below:

**IMPORTANT!** Your Rider is equipped with a 12-volt system with negative earth. The other vehicle must also have a 12-volt system with negative earth. Do not use your Rider battery to start other vehicles.

## Connecting the jump leads

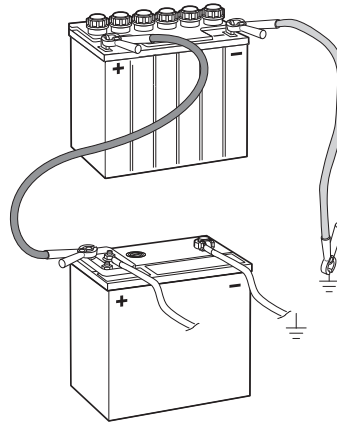

**WARNING! Never connect the negative terminal of the fully-charged battery to, or in the vicinity of, the negative terminal of the discharged battery. Hydrogen gas may be present with risk of explosion.**

- Connect each end of the red cable to the POSITIVE pole (+) on each battery, exercise care not to short circuit any of the ends against the chassis.
- Connect one end of the black cable to the NEGATIVE pole (-) on the fully charged battery.
- Connect the other end of the black cable to a good CHASSIS EARTH, away from the fuel tank and the battery.

## Remove the cables in the reverse order

- The BLACK cable is removed from the chassis and then the fully charged battery.
- Finally the RED cable from both batteries.

**IMPORTANT!** Never use a boost charger/start booster.

So called boost chargers/start boosters must never be used. These will often increase the voltage (instead of the current) to generate the power needed to start the engine. This increase in voltage will damage the electrical system.

# DRIVING

## Driving the Rider

- 1 Release the parking brake by first pressing down the parking brake pedal and then releasing it.

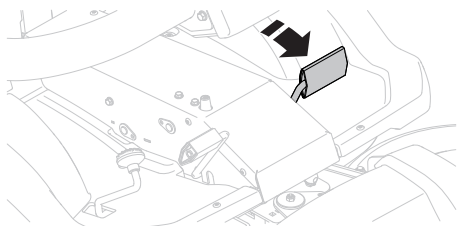

- 2 Carefully press down one of the pedals until the required speed is obtained. Pedal (1) is used to drive forwards, and pedal (2) to drive backwards.

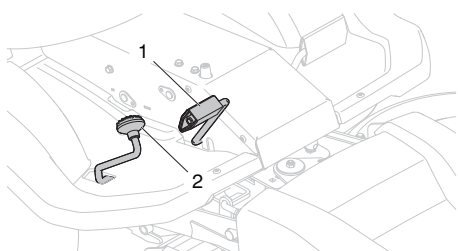

- 3 Lower the cutting unit by directly moving the lever forward to the float position where the lever stays put.

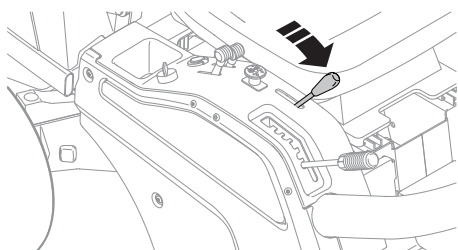

- 4 Select the required cutting height (1-6) with the cutting height lever.

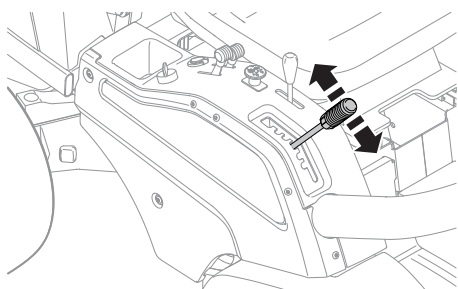

- 5 Start the cutting unit if necessary by pulling up the switch for the cutting unit.

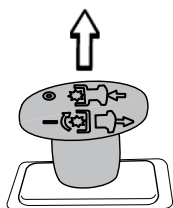

In order to obtain an even cutting height, it is important that the air pressure is the same in both front wheels. See the "Technical data" section.

**CAUTION!** The life span of the drive belts is increased significantly if the engine runs at a low speed when the blades are engaged. Therefore apply full throttle first when the cutting unit has been moved to the mowing position.

## Braking

Release the drive pedals. The machine slows and is stopped by the drive system. Do not use the parking brake as the drive brake.

Quicker braking is possible if you press down the drive pedal for the opposite direction.

## Stop the engine

Always park the machine on a level surface with the engine OFF. Preferably allow the engine to idle for a minute to obtain normal working temperature before stopping it if it has been working hard.

- 1 Turn off the cutting unit using the PTO button.

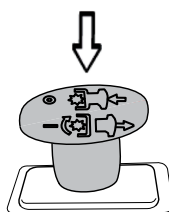

- 2 Lift the cutting unit with the hydraulic lifting lever.

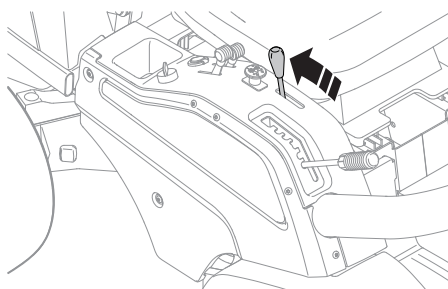

- 3 Move the throttle control to the MIN. position. Turn the ignition key to the "STOP".

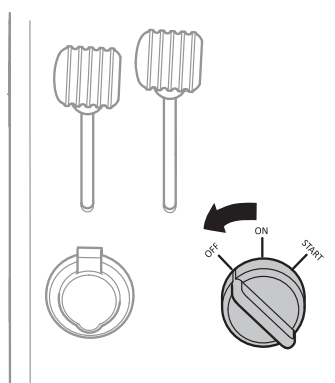

- 4 When the machine is at a standstill, hold down the parking brake (1) and depress the lock button (2).

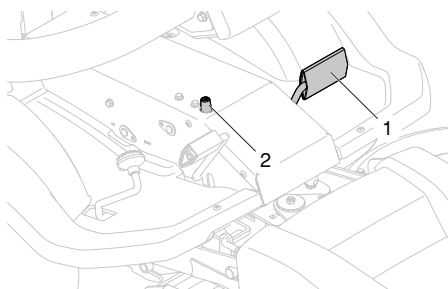

# Maintenance

## Maintenance schedule

The following is a list of the maintenance which should be conducted on the machine. For those points not described in this manual, visit an authorised service workshop.

Maintenance	Daily maintenance	After the first 25 hours	Weekly maintenance <sup>1)</sup>	At least once a year	Maintenance interval in hours			
					40	100	200	400
Cleaning	X							
Clean the air filter.					X	X	X	
Clean thoroughly around transmission			X					
Check the engine's oil level	X							
Check the engine's cooling air intake	X							
Check the fuel pump air filter	X							
Check the safety system	X							
Check nuts and screws	O							
Check for fuel and oil leakage.	O							
Clean around the silencer	O							
Start engine and blades, listen for noise	O							
Clean transmission air intake	X				X			
Lubricate according to lubrication schedule, see under heading "LUBRICATION"		X			X	X		
Change engine oil <sup>1)</sup>		X			X	X	X	
Check the cutting deck	X							
Check and adjust the air pressure in the tyres (100 kPa, 1.0 bar, 14.5 PSI).					X	X	X	
Lubricate belt tensioner (nipple)			X		X			
Lubricate the driver's seat			X					
Lubricate all wires			X					
Lubricate bearing surfaces on cutting unit			X					
Clean inside frame tunnel			X					
Lubricate the pedal system in the frame tunnel			X					

# Maintenance

Lubricate the hydrostatic cable with links			X					
Check the parking brake	X							
Lubricate the parking brake wire			X					
Lubricate throttle control			X					
Lubricate choke control			X					
Lubricate the chain in the frame tunnel			X					
Check the V-belts					O			
Checking the transmission oil level			X					
Checking and adjusting the choke wire						X		
Tighten the nuts and screws							O	
Checking and adjusting of throttle wire						O		
Replace the fuel filter.		X				X	X	
Replace the spark plug.						X	X	
Replace the engine oil filter					X			
Check/adjust front and rear wheel rotation speed according to the service schedule <sup>4)</sup>					O	O	O	O

<sup>1)</sup>If the machine is used daily it should be lubricated twice a week. <sup>2)</sup> Conducted by authorised service workshop.

X = Described in this operator's manual

O = Not described in this operator's manual

**IMPORTANT!** When the machine is in operation the hoses are under high pressure. Do not try to connect or disconnect the hoses when the hydraulic system is operational. This can result in serious personal injuries.



**WARNING! No service procedures must be conducted on the engine or cutting unit unless:**

**The engine is switched off.**

**The parking brake is applied.**

**The ignition key is removed.**

# Maintenance

## Cleaning

Clean the machine directly after use. It is much easier to wash off grass cuttings before they dry.



Oily dirt can be removed using a cold degreasing agent. Spray on a thin layer.

Rinse at normal water pressure.

Do not direct the jet towards electrical components or bearings.

Do not rinse hot surfaces such as the engine and exhaust system.

It is recommended that you start the engine and run the mower for a short period after cleaning, so that any remaining water is blown off.

Lubricate the machine if necessary after cleaning. Carry out extra lubrication when the bearings have been exposed to a degreaser or a water jet.

### IMPORTANT!

Avoid using a high pressure washer or a steam cleaner.

There is a major risk of water penetrating into bearings and electrical connections. Corrosion attack can result, which will lead to running problems. Cleaning additives generally aggravate the damage.

## Removing of the machine hoods

### Engine cover

- Pull the seat forward to its foremost position.
- Fold up the seat.
- Pull out the 2 cotter pins behind the seat and remove the 2 clevis pins, one on each side.
- Pull the snap catches on the engine cover backwards. The snap catches are located on the inside of the engine frame.

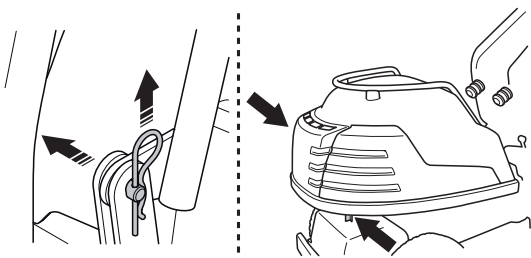

- Lift off the engine cover upwards.

### Front cover

- Release the clip on the front hood and lift off the fender.

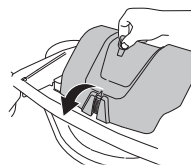

- The front cover is secured to the unit frame with two hooks.

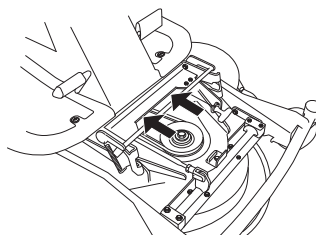

### Right-hand fender

- Remove the accelerator knob (1), screws (2 and 3), and remove the cover.

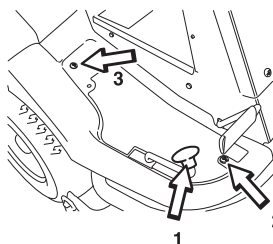

### Left-hand fender

- Remove the screws holding the wing cover (2) and lift off the cover.

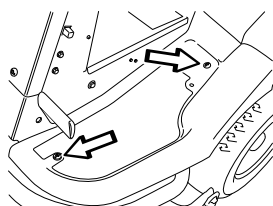

### Side cover

- Loosen the screws holding the side cover and remove it.

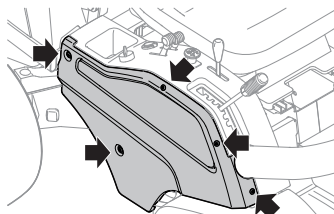

### Rear cover

- Remove the screws and lift off the fender.

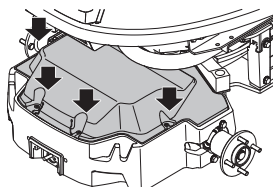

# Maintenance

## Adjusting the parking brake



**WARNING! A poorly adjusted parking brake can result in reduced braking ability.**

Make sure the parking brake is properly adjusted by placing the machine on a slope.

Apply and lock the parking brake. When the machine does not stand still, the parking brake should be adjusted according to the following.

- 1 Position the machine on flat ground.
- 2 Make sure the parking brake is released.
- 3 Remove the left-hand wing cover.
- 4 Loosen the locking nuts.
- 5 Adjust the play between the casing and the adjustment screw to 1 mm (0.040") when one pulls the casing. This gives a play on the pedal of approximately 40 mm.

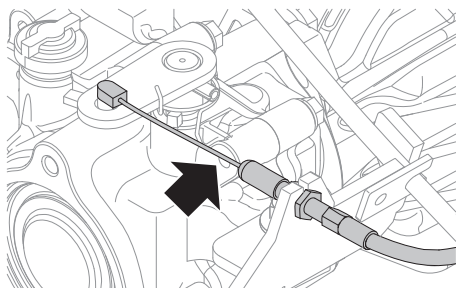

- 6 Tighten the nuts carefully to prevent damaging the adjuster screw.
- 7 The brake should be checked again after adjustment
- 8 Assemble the left-hand wing cover.

## Checking the throttle wire

Check that the engine responds to the throttle control and that the correct engine speed is achieved at full throttle.

If doubts arise, contact your service representative.

## Checking the choke wire

If the engine is producing black smoke or is difficult to start then the choke wire (upper wire) may be incorrectly adjusted.

If doubts arise, contact your service representative.

## Replacement of fuel filter

Replace the fuel filter every 100 running hours (once per season) or more frequently if it is clogged.

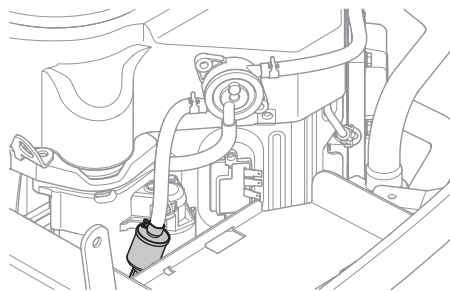

Replace the filter as follows:

- 1 Open the engine cover.
- 2 Move the hose clips away from the filter. Use a pair of flat pliers.
- 3 Pull off the filter from the hose ends.
- 4 Press the new filter into the ends of the hoses. If necessary apply liquid detergent to the ends of the filter to facilitate connection.
- 5 Push the hose clips back on the filter and tighten.

## Checking the fuel pump's air filter

Check regularly that the fuel pump's air filter is free from dirt.

The filter can when necessary be cleaned with a brush.

- Remove the screws and open the pump, no hoses need be removed.

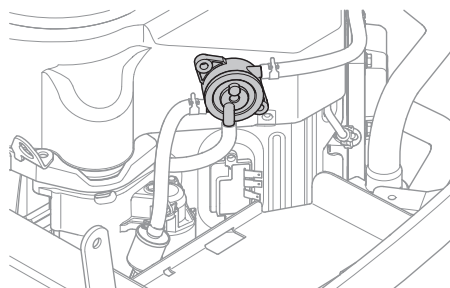

- Replace the pump on the console.

# Maintenance

## Replacing the air filter



**WARNING!** The exhaust system is hot. Let it cool before starting to replace the air filter.

If the engine seems to lack power or does not run smoothly this may be because the air filter is clogged. It is therefore important to replace the air filter at regular intervals (see Maintenance schedule for correct service interval).

Replace the air filter as follows:

- 1 Open the engine cover.
- 2 Loosen the two fasteners holding the filter cover and remove it.

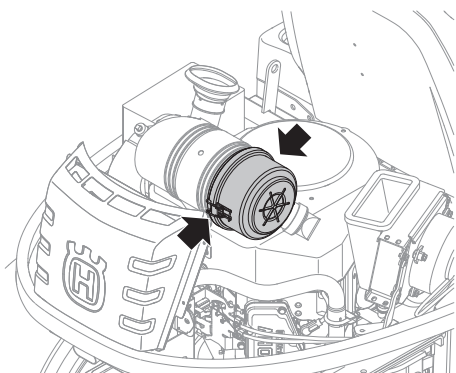

**IMPORTANT!** Never run the engine without the air filter fitted.

The filters must not be oiled. They must be fitted dry.

- 3 Remove the filter cartridge from the filter housing.

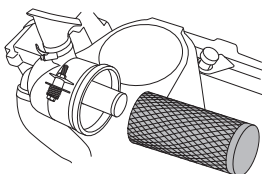

- 4 Clean the filter by knocking the filter carefully against a hard surface and blowing with compressed air from inside. Never brush the dirt away. Replace the air filter if it is very dirty.

P524 have an additional filter located behind the filter cartridge. Clean the filter by knocking it with care against a hard surface. Do not use compressed air for this filter.

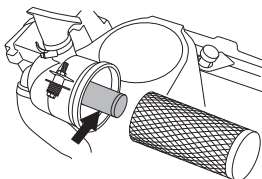

- 5 Replace the filter cartridge. Make sure the filter cartridge is correctly fitted over the air intake in the filter housing.

- 6 Replace the air filter cover, ensure that the particle collector is facing downwards.

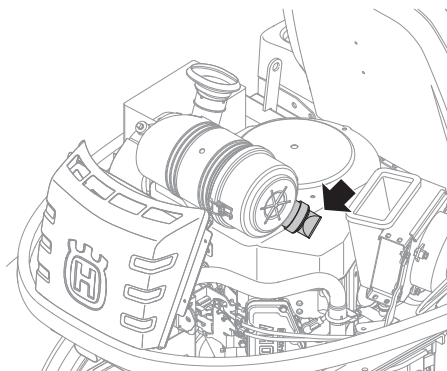

## Ignition system

The engine is equipped with an electronic ignition system. Only the spark plug requires maintenance.

For recommended spark plug, see Technical data.

**CAUTION!** Fitting the wrong spark plug type can damage the engine.

## Replacing the spark plug

- 1 Remove the ignition cable shoe and clean around the spark plug.
- 2 Remove the spark plug with a 3/4" (19 mm) spark plug socket wrench.
- 3 Check the spark plug. Replace the spark plug if the electrodes are burned or if the insulation is cracked or damaged. Clean the spark plug with a steel brush if it is to be reused.
- 4 Reinsert the spark plug, turning by hand to avoid damaging the threads.
- 5 After the spark plug is seated, tighten it using a spark plug wrench so that the washer is compressed. A used spark plug should be turned 1/8 of a turn from the seated position. A new spark plug should be turned a 1/4 turn from the seated position.
- 6 Replace the ignition cable shoe.

**CAUTION!** Inadequately tightened spark plugs can cause overheating and damage the engine. Tightening the spark plug too much can damage the threads in the cylinder head.

# Maintenance

## Cleaning the engine and muffler

Keep the engine and muffler free from grass cuttings and dirt. Grass cuttings steeped in petrol or oil on the engine can increase the fire risk and impair cooling.

Allow the engine to cool before cleaning. If the dirt is mixed with oil, remove it using a degreasing agent otherwise just water and a brush.

Grass cuttings around the muffler dry quickly and constitute a fire risk. Brush or wash them off when the muffler is cold.

## Check the safety system

The machine is equipped with a safety system that prevents starting or driving under the following conditions.

The engine must only be possible to start when the following conditions are met:

- Drive - blades deactivated PTO button not activated.
- The parking brake is applied.

The engine must stop under any of the following conditions:

- The cutting deck is lowered and the driver rises from the seat.
- The cutting deck is in its raised position, the parking brake is not applied and the driver rises from the seat.

Check daily to ensure that the safety system works by attempting to start the engine when one of the conditions above is not met. Change the conditions and try again.

## Replacing the light bulbs

For information about the bulb type, see Technical Data.

- 1 Unscrew the four screws holding the cover on the power servo housing.

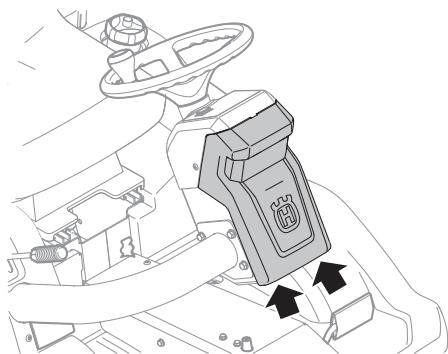

- 2 Unscrew the two screws holding the lamp insert.

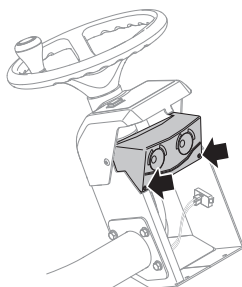

- 3 Lift out the lamp insert.

- 4 Disconnect the cables from the bulbs.

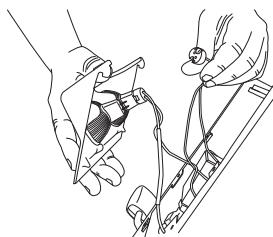

- 5 Lift out the bulbs from the insert.

- 6 Insert the new bulbs. Make sure you use your thumb to support the front.

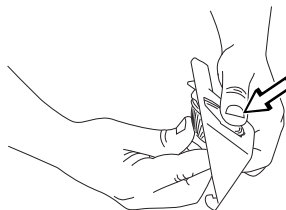

- 7 Refit the cables, lamp insert and the cover on the power servo housing.

## Main fuse

The main fuse is placed in a detachable holder under the battery. Type: Flat pin, 20 A.

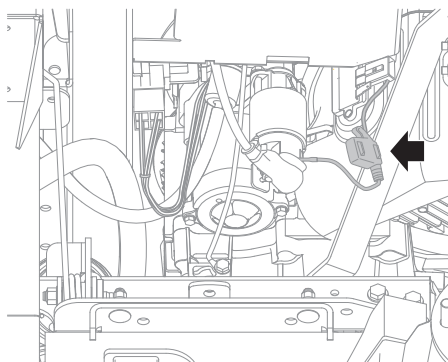

The fuse for the power outlet is placed under the control panel. Type: Flat pin, 5 A.

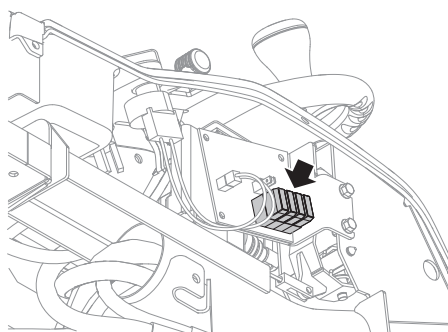

Do not use any other type of fuse when replacing.

A blown fuse is indicated by a burnt connector. Pull the fuse from the holder when replacing.

The fuse is there to protect the electrical system. If it blows again shortly after replacement, it is due to a short circuit, which must be fixed before the machine can be put into operation again.



# Maintenance

## Checking the tyre pressure

The tyre pressure should be 1,0 bar / 100 kPa / 14,5 PSI for all wheels

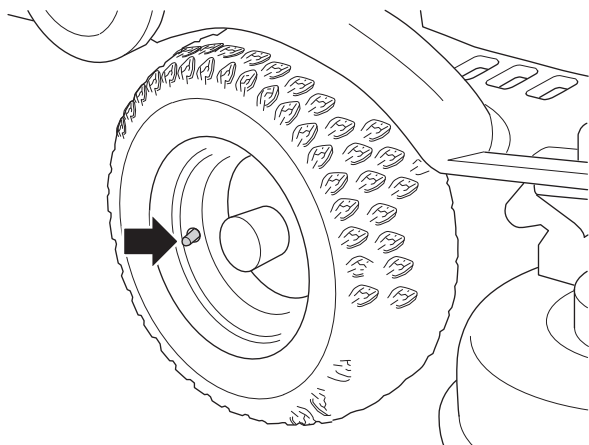

### IMPORTANT!

Different tyre pressures on the front tyres will result in the blades cutting the grass at different heights.

## Checking the engine's cooling air intake



**WARNING!** The cooling air intake rotates when the engine is running. Mind your fingers.

Clean the air intake grille in the engine cover behind the driver's seat.

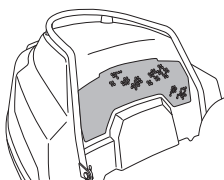

- Open the engine cover.
- Check that the cooling intake is free from leaves, grass and dirt.

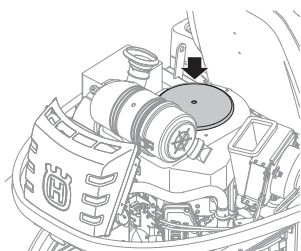

- Check the air duct, located on the inside of the engine cover, ensure it is clean and does not rub against the cooling air intake.

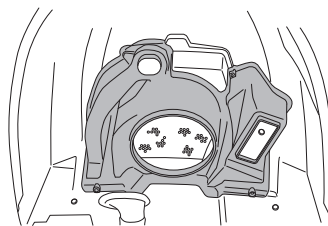

A blocked cooling intake will interfere with the cooling of the engine, which can damage the engine.

## Replacing the cutting belt

### Dismantling

The entire cutting unit belt is removed according to the following when a snow blade is to be attached to the machine.

- 1 Lower the cutting unit.
- 2 Remove the front cover.
- 3 Loosen the automatic belt tensioner stay.

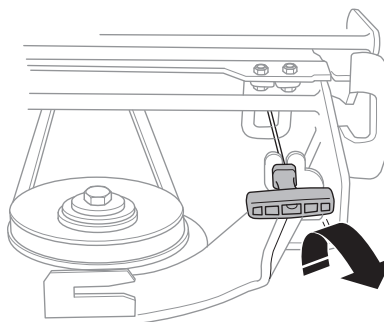

- 4 Remove the left-hand wing cover.
- 5 Pull the spring stay from the lifting chain.

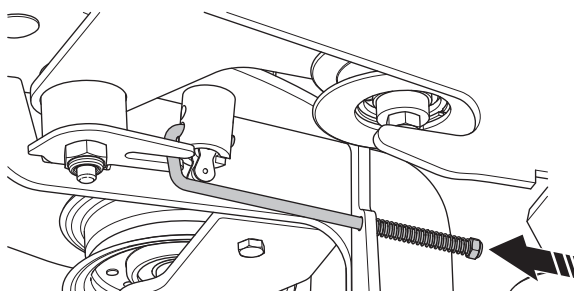

- 6 Unscrew the belt shield.

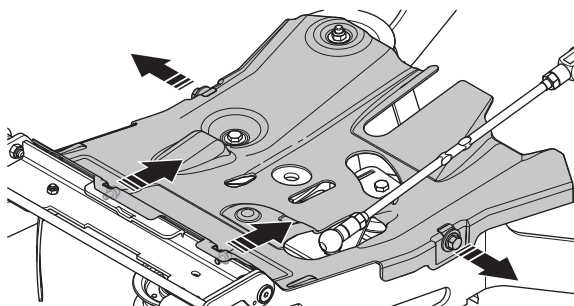

# Maintenance

- 7 Prise the belt off the pulley, lift the belt tensioner and prise the belt off the belt tensioner.

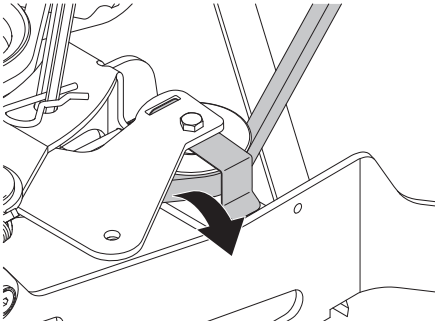

- 8 Release the belt from the pulley on the tool frame.

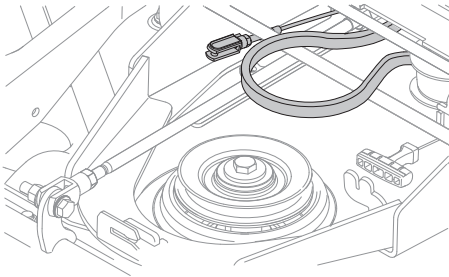

- 9 Remove the belt guard under the engine pulley.

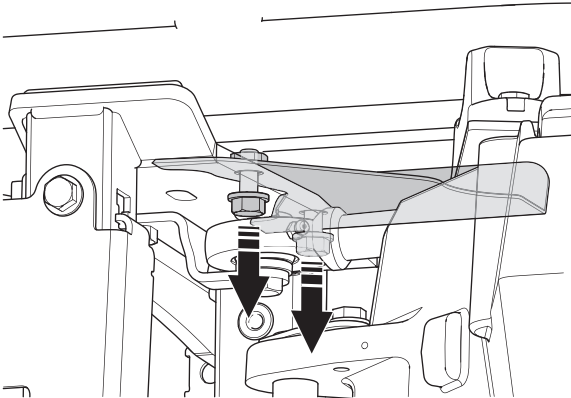

- 10 Remove the belt guard over the rear transmission.

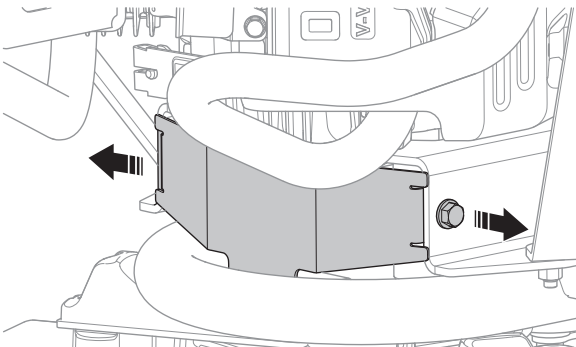

- 11 Lift the belt off the engine pulley.

- 12 Remove the belt guard on the right side of the machine.

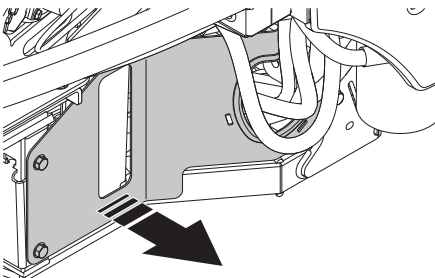

- 13 Pull the front part of the belt out through the right side of the machine's articulation.

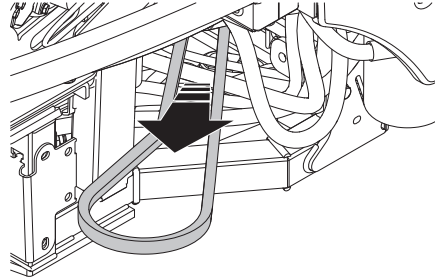

- 14 Unhook the belt from the hook on the center belt pulley.

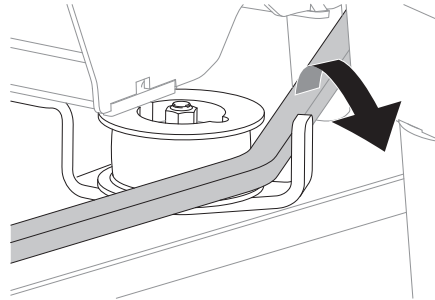

- 15 Pull out the belt.

Simply reverse the procedure to fit the new belt.

Fit a new cutting unit belt according to the belt position diagram.

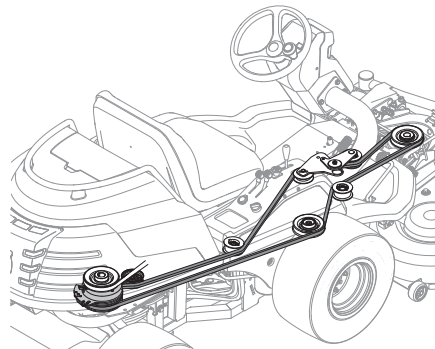

Make sure the cutting unit belt sits correctly in the adjuster pulley.

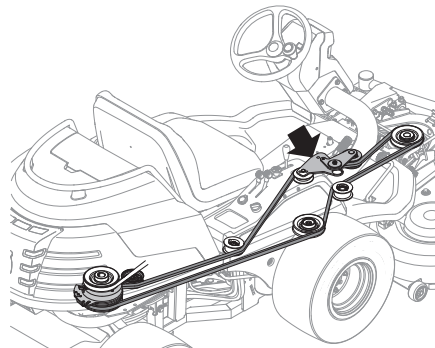

# Maintenance

## Fitting the cutting head



**WARNING! Wear protective glasses when fitting the cutting unit. The spring which tensions up the belt may break and cause personal injury.**

- 1 Place the machine on a flat surface and apply the parking brake. Check that the lever for setting the cutting height is in the S position.
- 2 Push the equipment frame down and place the catch against the frame.

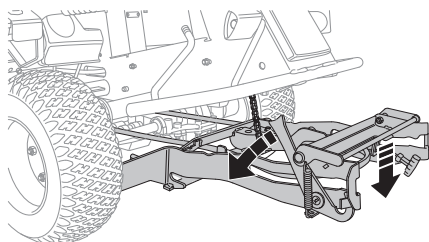

- 3 Push the deck in and put the front guide plugs in the grooves on the equipment frame, one on each side.
- 4 Push the unit in so that the interior plugs touch the bottom of the equipment frame's grooves.
- 5 Place the cutting unit belt around the cutting unit drive wheel and hook on the height adjustment cable.
- 6 Secure the collet spring.
- 7 Fit the front cover.

## Removing the cutting unit

- 1 Place the machine on a flat surface and apply the parking brake.
- 2 Carry out points 1-6 to put the cutting unit in the service position, see Service position for the cutting unit.
- 3 Open the unit catch.

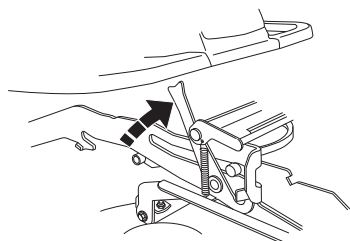

- 4 Pull out the cutting unit.

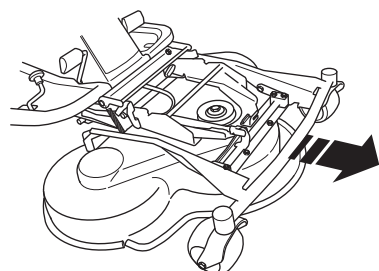

**WARNING! Observe caution to avoid trapping your hand.**

## Service position for the cutting unit

The cutting head can be placed in the service position to provide easy access for cleaning, repairs and servicing. In the service position the cutting unit is raised and locked in the vertical position.

### Placing in the service position

- 1 Position the machine on flat ground.
- 2 Apply the parking brake.
- 3 Set the cutting height control in the lowest position and lift up the cutting unit.

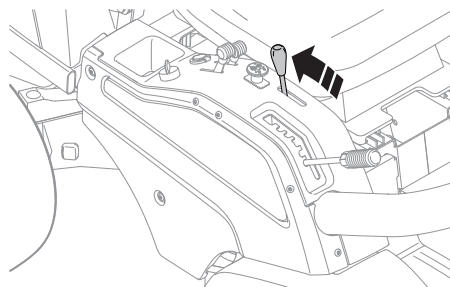

- 4 Release the clip on the front hood and lift off the fender.

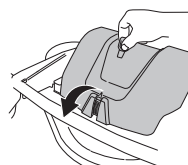

- 5 Disengage the spring for the drive belt tensioning wheel.

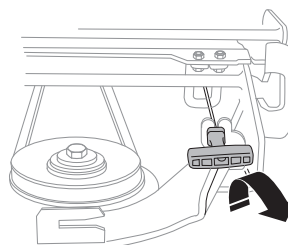

- 6 Loosen on the cutting height stay and place in the holder.

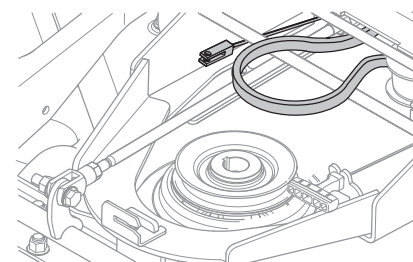

- 7 Remove the drive belt and place it in the belt holder.
- 8 Grip the front edge of the unit and pull forwards until it stops.

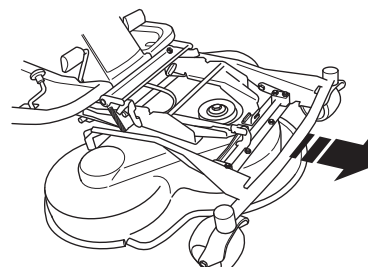

# Maintenance

- 9 Lift the unit until it stops and a clicking sound is heard. The unit locks automatically in the vertical position.

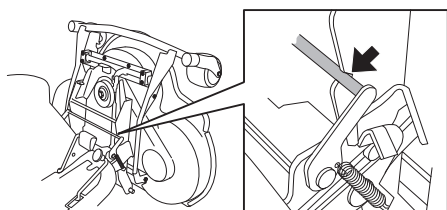

## Restoring from service position

- 1 Grip the front edge of the unit and loosen the lock, fold down and slide in the unit.
- 2 Replace the cutting height stay and the belt.
- 3 Tension the belt with the belt adjuster.

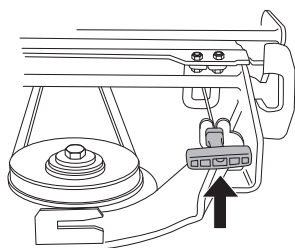

- 4 Fit the front cover.

## Checking and adjustment of the cutting unit's ground pressure

To achieve the best cutting results the cutting unit should follow the underlying surface without pressing too hard against it. Pressure is adjusted using a screw and spring on each side of the Rider.

The adjustment must be made in the stated order.

Starting position:

- 1 Check the tyre pressures. The tyre pressure should be 0,8 bar / 80 kPa / 11,6 PSI for all wheels
- 2 Place the machine on a flat surface.
- 3 Put the lifting lever in the mowing position.
- 4 Place a set of bathroom scales under the cutting unit's frame (front edge) so that it rests on the scales. If necessary a block can be placed between the frame and scales so that the support wheels do not bear any weight.

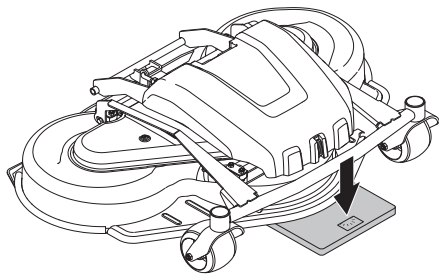

- 5 Adjust the cutting unit's ground pressure by screwing the adjuster screws, which are located behind the front wheels on both sides, in or out. The ground pressure should be between 12 and 15 kg and the springs evenly tensioned.

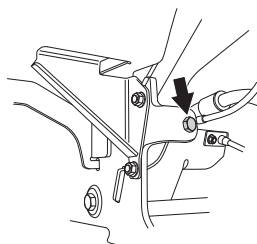

## Checking the cutting unit's parallelism

Check the cutting unit's parallelism as follows:

- 1 Check the tyre pressures.
- 2 Place the machine on a flat surface.
- 3 Put the lifting lever in the mowing position.
- 4 Measure the cutting deck at the front and the rear. The rear dimension should always be at least 4 mm higher than the front.

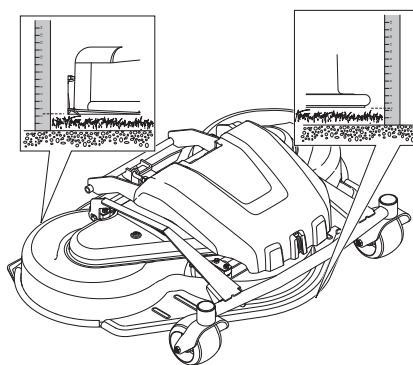

# Maintenance

## Adjusting the parallelism of the cutting unit

- 1 Remove the front hood.
- 2 Undo the nuts on the lift strut.

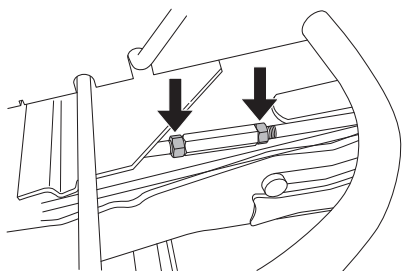

- 3 Screw out (extend) the stay to raise the rear edge of the cover. Screw in (shorten) the stay to lower the rear edge of the cover.

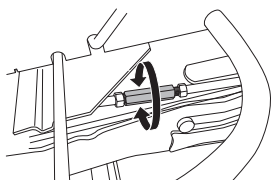

- 4 Tighten the nuts after adjustment.
- 5 On completion of the adjustment the unit's parallelism should be re-checked.
- 6 Fit the front cover.
- 7 On completion of the adjustment the unit's parallelism should be re-checked.

## Replacing the cutting unit belts



**WARNING! Protect your hands with gloves. There is a risk of crush injuries when working with the belt.**

On these cutting units with collision-proof blades, the blades are driven by one V-belt. Do as follows to change the V-belt:

- 1 Remove the cutting unit.
- 2 Open the lock for the track rod bolt.

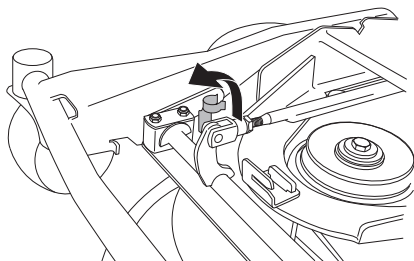

- 3 Unscrew the bolt holding the unit frame bracket.

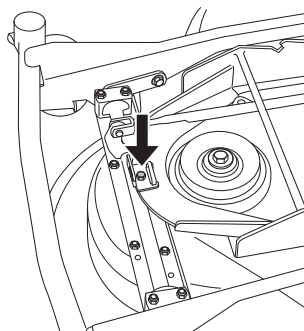

- 4 Remove the lock and pass the unit frame out.
- 5 Remove the two bolts on the unit frame.

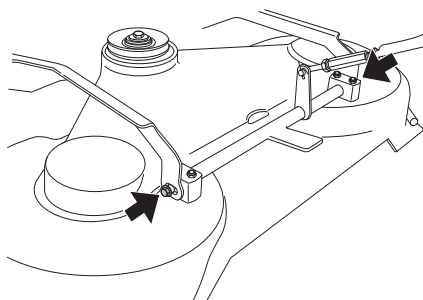

- 6 Remove the screws on the cutting cover. Lift the unit frame and remove the cutting unit cover.



- 7 Loosen the spring that tensions the V-belt and pry off the belt.

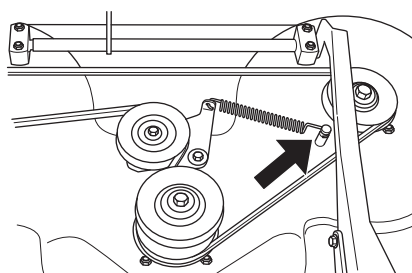

Assemble the parts in the reverse order.

# Maintenance

## Checking the blades

To achieve the best mowing results it is important that the blades are undamaged and well-sharpened.

Check that the blades' attachment screws are tight.

**IMPORTANT!** One or more unbalanced blades, caused by damage or poor balancing after sharpening, can cause vibrations in the machine.

The blades should be balanced after sharpening.

Damaged blades should be replaced when hitting obstacles that result in a breakdown.

## Replacing the blades

- Put the unit in the service position, see Service position for the cutting unit.
- Lock the blade with a wooden block. Loosen the blade bolt and remove the blade bolt, the washers and the blade.

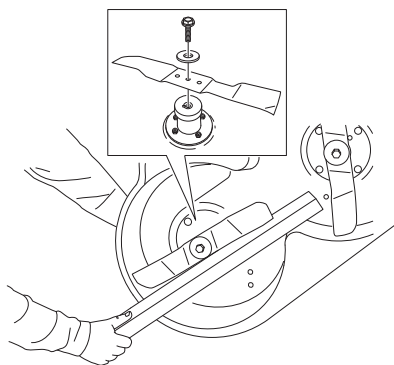

Assemble the parts in the reverse order.

- The blade must be mounted with the angled ends pointing up towards the cover.

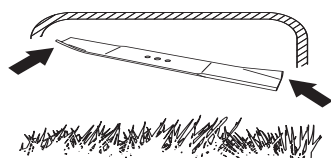

- Tightening torque **45-50 Nm** (4.5-5 kpm/32-36 lbft).



**WARNING!** Wear gloves to protect your hands when working with the blades.

**IMPORTANT!** Always exercise care and use your common sense. Avoid all situations which you consider to be beyond your capability. If you still feel uncertain about operating procedures after reading these instructions, you should consult an expert before continuing. Contact a servicing dealer.

Always use genuine parts. For more information, see the "Technical data" section.

## Removing the BioClip plug

To change a Combi unit from BioClip function to cutting unit with rear ejection, remove the BioClip plug located under the unit with three screws.

- 1 Put the unit in the service position, see Placing in the service position.
- 2 Remove the three screws holding the BioClip plug, and remove the plug.

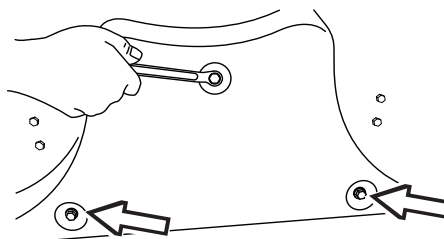

- 3 Tip: Fit three full-thread screws M8x15 mm in the screw holes to protect the threads.
- 4 Replace the unit in normal position.

Fit the BioClip plug in the reverse order.

## Check the hydraulic system oil level

The oil and filter should be changed by an authorised service representative, as described in the Workshop Manual. Work on the system entails particular demands on cleanliness and the system must be vented before the machine is used.

- Fold up the seat.
- Remove the filler cap. The level should be 40-60 mm from the strainer top.

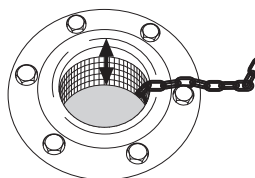

- Refill as required with fully synthetic 10W/50 API SM oil or better

## Hydraulic oil filter change

- Turn the old oil filter anti-clockwise to remove. If necessary, use a filter remover.

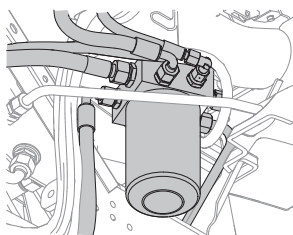

- Lightly lubricate the rubber seal on the new oil filter using new oil.
- Tighten the filter by hand until you feel it make contact, then tighten a further 3/4 turn. Remove the transmission cover and fill the transmission's oil tank, about 0.3 l oil. Be observant when running the engine as described below and fill so that the tank is not emptied.

# Maintenance

- Run the engine warm, manipulate the servo steering, and then check that there are no leaks around the oil filter seal.
- Check the oil level in the transmission, top up if necessary. The oil filter holds 0.3 litres of oil.

## Check the oil level in the transmission

- Use the oil dipstick to check that there is oil in the transmission.

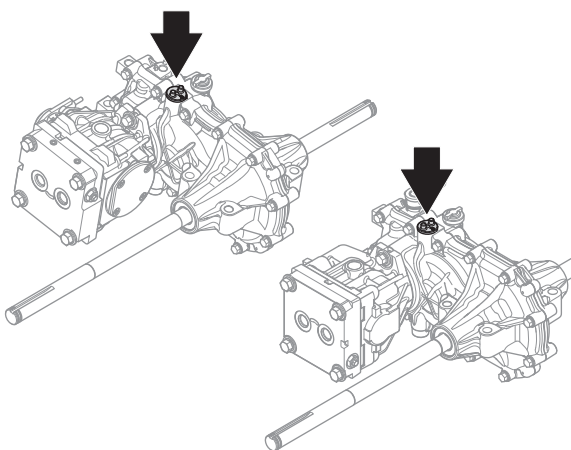

- The oil level should be between the markings on the dipstick.



- Refill as required with fully synthetic 10W/50 API SM oil or better

## Checking the engine's oil level.

Check the oil level in the engine when the Rider stands horizontal with the engine switched off. Do not check the oil with the engine running.

- Open the engine cover.
- Loosen the dipstick, pull it up and wipe it off.

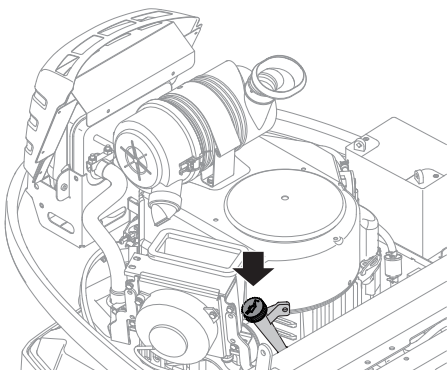

- Now insert the dipstick again, **without tightening it**.
- Pull the dipstick out again and read the oil level.

The oil level should be between the markings on the dipstick. If the level is approaching the ADD mark, top up the oil to the FULL mark on the dipstick.

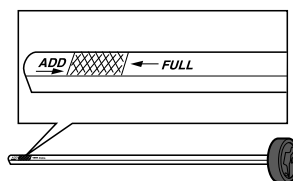

The oil is topped up through the hole the dipstick sits in.

- Tighten the dipstick correctly before starting the engine.
- Start and run the engine at idling speed for approx. 30 seconds.
- Turn off the motor.
- Wait 30 seconds and check the oil level.
- If necessary fill so that the oil comes up to the FULL mark on the dipstick.

The following oil classes are recommended:

- API class SH or better

Choose an oil with viscosity according to the temperature ranges in the figure:

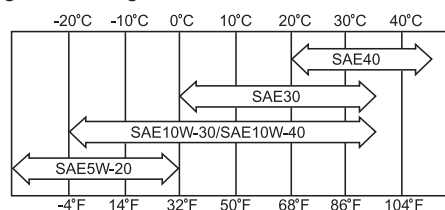

Do not mix different types of oil.

Caution when using oils such as 5W-20, 10W-30 and 10W-40 the engine's oil consumption increases. If these oils must be used, check the oil level frequently.

# Maintenance

## Replacing the engine oil

- Open the engine cover.

The engine oil should be changed the first time after 25 hours running time. It should then be changed after every 100 hours of running time.

When operating with a heavy load or at high ambient temperatures, replace every 50 hours.



**WARNING! Engine oil can be very hot if it is drained directly after stopping the engine. Allow the engine to cool somewhat first.**

- 1 Place a container underneath the engine oil drain plug.

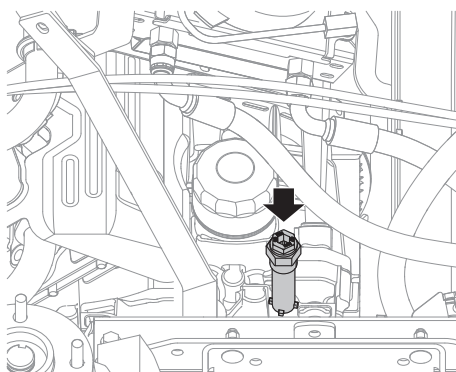

- 2 Remove the dipstick. Remove the drain plug from the engine.
- 3 Let the oil run out into the container.
- 4 Fit the drain plug and tighten it.
- 5 If necessary fill so that the oil comes up to the FULL mark on the dipstick. The oil is topped up through the hole the dipstick sits in.
- 6 Run the engine warm, then check that there is no leakage from the oil plug.
- 7 Check the engine oil level and top up if necessary.

### IMPORTANT INFORMATION

Used engine oil, antifreeze etc. is a health hazard and must not be disposed of on the ground or in nature; it should always be disposed of at a workshop or appropriate disposal location.

Avoid skin contact; wash with soap and water in case of spills.

## Changing the oil filter



**WARNING! Engine oil can be very hot if it is drained directly after stopping the engine. Allow the engine to cool somewhat first.**

- Open the engine cover.

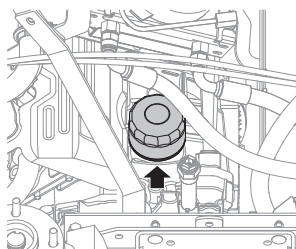

- Turn the old oil filter anti-clockwise to remove. If necessary, use a filter remover.
- Lightly lubricate the rubber seal on the new oil filter using new oil.
- Fit the oil filter by turning clockwise. Turn by hand until the rubber seal is seated. Now tighten a further half turn.
- Start the engine and let it idle for about 3 minutes. Now stop it and check for signs of leakage.
- Check the engine oil level and top up if necessary.

### IMPORTANT!

Used engine oil and transmission oil is hazardous to health and must not be disposed of in the ground or out of doors.

Replaced filters must be handed in to the workshop or other allotted place for disposal.

Avoid skin contact; wash with soap and water in case of spills.



# Lubrication

## Lubrication schedule

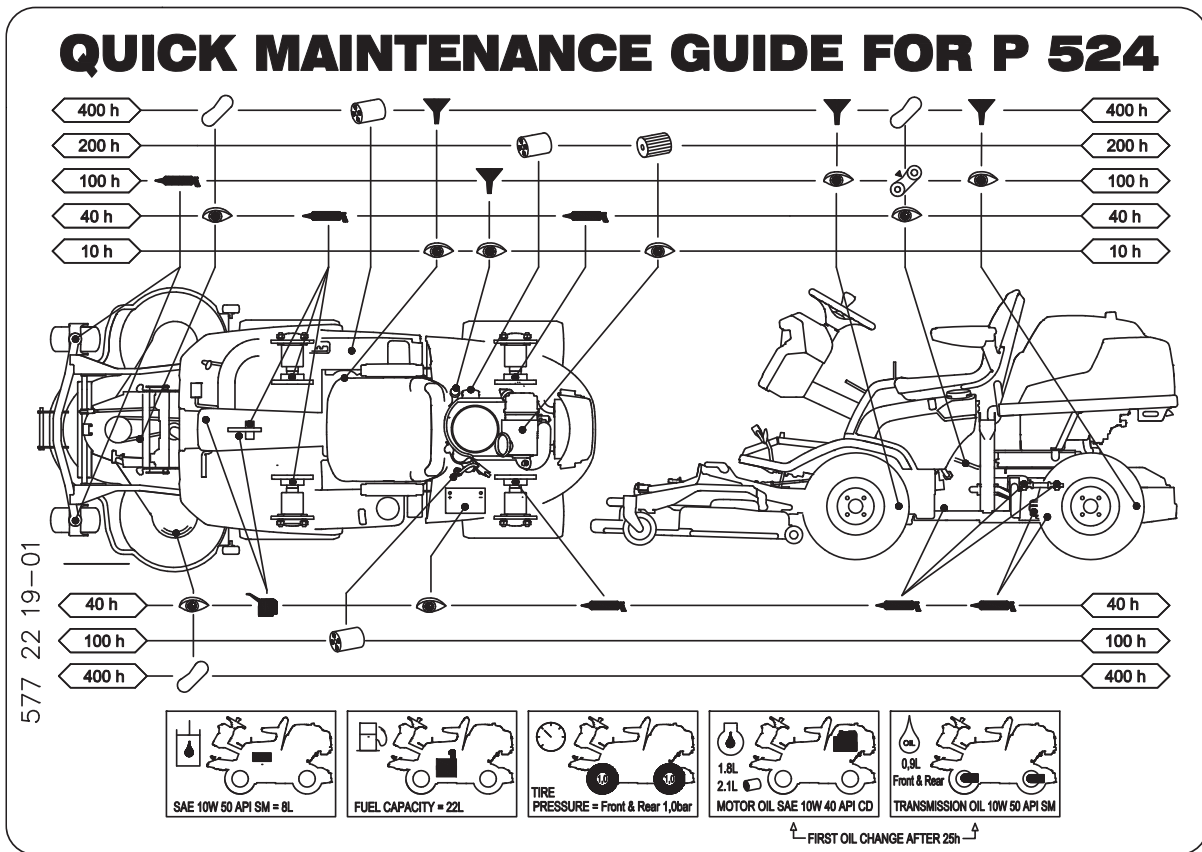

### Legend for the lubrication schedule

Filter replacement



Oil change



Level check



Grease nipple



Oil can



Check belts, condition and belt tension



Belt replacement



# Lubrication

## All lubrication points

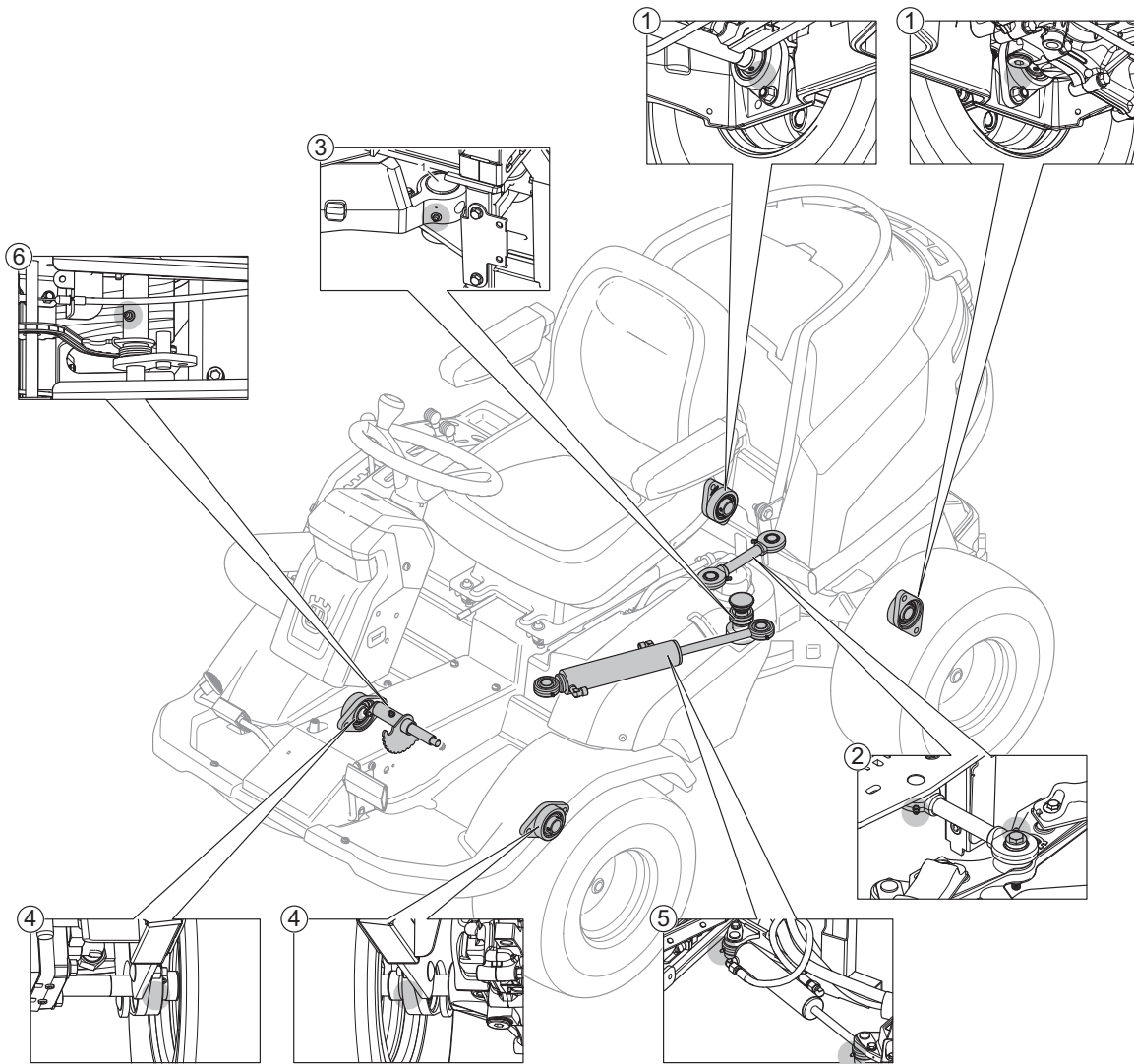

1	Bearing unit - rear axle
2	Link brace
3	Articulated Bearing
4	Bearing unit - front axle
5	Steering cylinder
6	Axle for lifting chain

## General

Remove the ignition key to prevent unintentional movements during lubrication.

When lubricating with an oilcan, it ought to be filled with engine oil.

When lubricating with grease, unless otherwise stated, grease 503 98 96-01 or another chassis or ball bearing grease offering good corrosion protection shall be used.

If the machine is used daily it should be lubricated twice a week.

Wipe away excess grease after lubrication.

It is important to avoid getting lubricant on the belts or the drive surfaces on the belt pulleys. Should this happen, attempt to clean them with spirits. If the belt continues to slip after cleaning with spirits, it must be replaced.

Petrol or other petroleum products must not be used to clean belts.

# Lubrication

## Accessories

Lubrication or other maintenance of optional equipment or accessories is not described in this manual. This equipment too, naturally, requires maintenance. See the manuals for the respective accessories for instructions.

## Lubricating the cables

Grease both ends of the cables and move the controls to end stop positions when lubricating.

Re-attach the rubber covers on the cables after lubrication.

Cables with sheaths will jam if they are not lubricated regularly. A jammed cable may cause malfunction, such as the parking braking being applied. If a cable binds, remove the cable and hang it vertically. Lubricate it with thin engine oil until the oil begins to escape from the bottom.

A tip: Fill a small plastic bag with oil and tape it so that it seals against the casing and allow the cable to hang vertically from the bag overnight. If you do not succeed in lubricating the cable, it must be replaced.

## Cutting unit

Remove the front cover.

Lubricate with oil.

- Joints and bearings

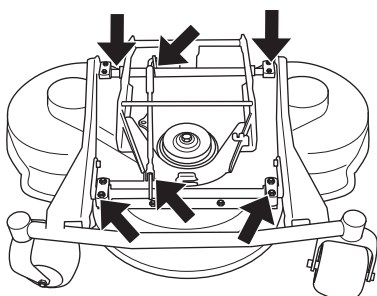

## Pedal system in the frame tunnel

Lubricate the pedal system in the frame tunnel.

- Remove the frame plate by loosening the screws.

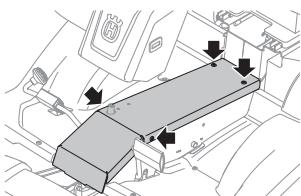

- Work the pedals and lubricate the moving parts with oil. Lubricate the cables for the brake and drive pedals with oil.

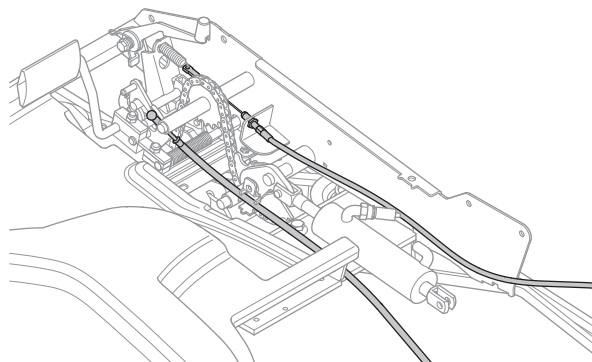

## Parking brake cable

- Remove the frame plate by loosening the screws.

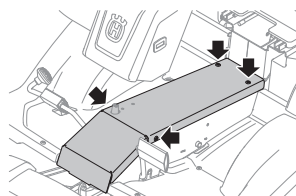

- Remove the left-hand wing cover.
- Lubricate both ends of the cable.

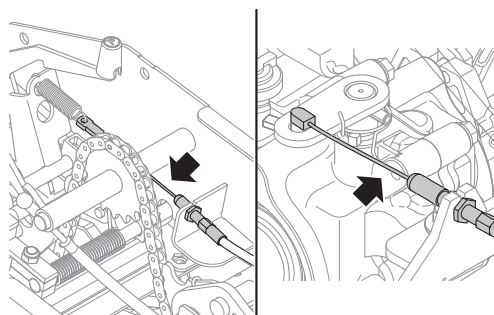

- Remove the cable's rubber casing when lubricating.
- Lubricate the cable with oil, press the brake pedal a few times and lubricate again.
- Refit the frame plate and wing cover.

## Chains in the frame tunnel

- Remove the frame plate by loosening the screws.
- Lubricate the chain in the frame tunnel with oil or chain lubricant spray.

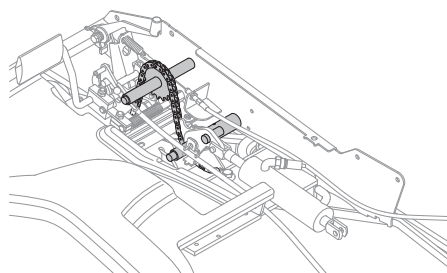

# Lubrication

## Links and joints in the cutting adjustment

- Lubricate the links and the joints for the cutting height adjustment stay behind the right front wheel.

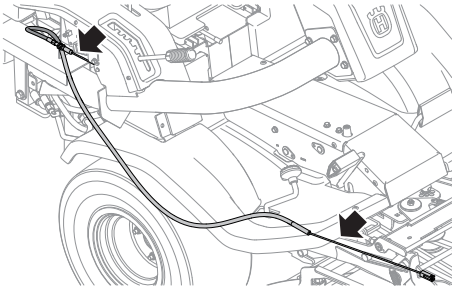

## Driver seat

- Fold up the seat.
- Lubricate the lengthways adjustment runners with oilcan.

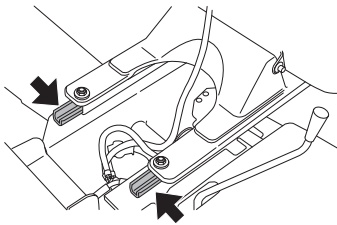

## Throttle and choke cables, lever bearings

- Remove the right side cover on the rear body.
- Lubricate the cables' free ends with the oilcan, even those by the engine.
- Move the controls to the end points and lubricate again.

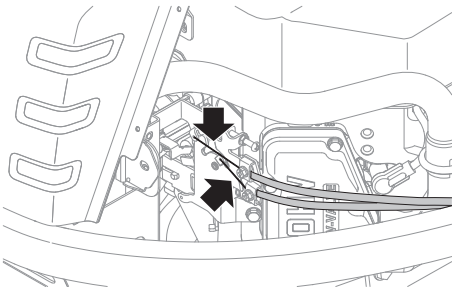

- Lubricate the joints, catches, and bearings for the cutting unit's control levers with oil.

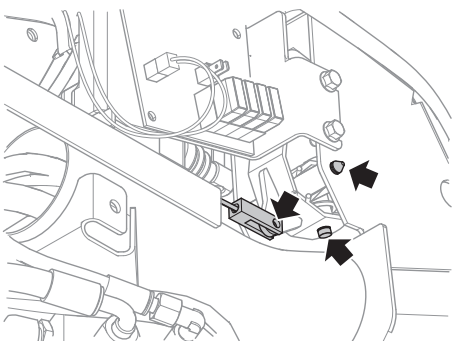

- Refit the cover.

## Lubricate the hydrostatic cable with links

- Lubricate the joints and bearings on the left side with oil.
- Remove the rubber casing and lubricate the hydrostatic transmission cable with oil.

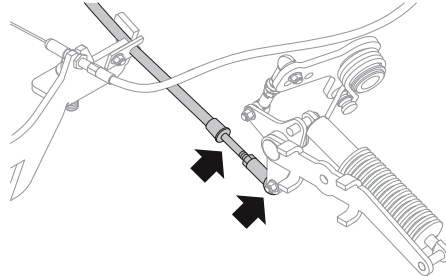

- Press the pedal a few times, lubricate again and refit the rubber casing.

## Steering cylinder

The steering cylinder has two grease nipples, one on each end.

- Lubricate with a grease gun until the grease is forced out.

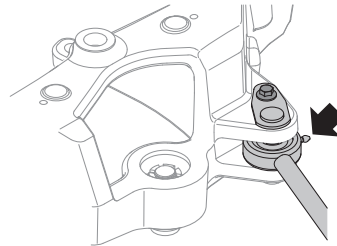

## Joint bearing

- Grease the waist section of joint bearing. Lubricate with a grease gun until the grease is forced out.

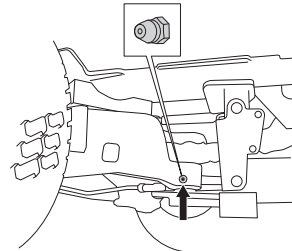

## Link brace

- 2 grease nipples, one on each side. Lubricate with a grease gun until the grease is forced out.

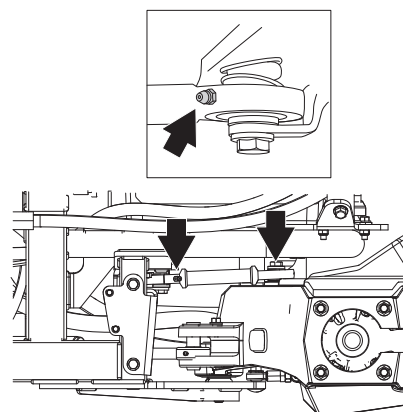

# Troubleshooting schedule

Problem	Cause
<b>Engine does not start</b>	There is no fuel in the fuel tank
	Spark plug defective
	Faulty spark plug connections or interchanged cables
	Dirt in the carburettor or fuel line
	Fuel tank vent blocked
<b>Starter motor does not turn over the engine</b>	Battery flat
	Poor contact affecting the battery terminal cable connections, ignition lock, or starter
	Power take off (PTO) activated
	Main fuse blown.
	Ignition lock faulty
	Faulty starter motor
	The parking brake is not on
<b>Engine does not run smoothly</b>	Faulty spark plug.
	Carburettor incorrectly set
	Air filter clogged
	Fuel tank vent blocked
	Ignition key defective
	Dirt in the carburettor or fuel line
	Choking or incorrectly adjusted throttle cable
<b>Engine seems to have no power</b>	Air filter clogged
	Faulty spark plug.
	Dirt in the carburettor or fuel line
	Incorrect carburettor adjustment.
	Choking or incorrectly adjusted throttle cable
<b>Engine overheats</b>	Engine overloaded
	Air intake or cooling flanges blocked
	Fan damaged
	Too little or no oil in engine
	Ignition defective
	Faulty spark plug.
<b>Battery does not charge</b>	The battery missing or damaged
	Poor contact on the battery terminal cable connectors
	Main fuse blown.
	Power consumption too high, max 20 A
<b>Machine vibrates</b>	Blades are loose
	Engine is loose
	One or more blades unbalanced, caused by damage or poor balancing after sharpening
<b>Uneven mowing</b>	Blades blunt
	Cutting unit skew
	Long or wet grass
	Grass blockage under hood
	Different tyre pressures on right and left front wheel
	Over-speeding
	Engine speed too low
	Drive belt slipping

---

# ELECTRICAL AND HYDRAULIC SYSTEMS

---

## Electrical system

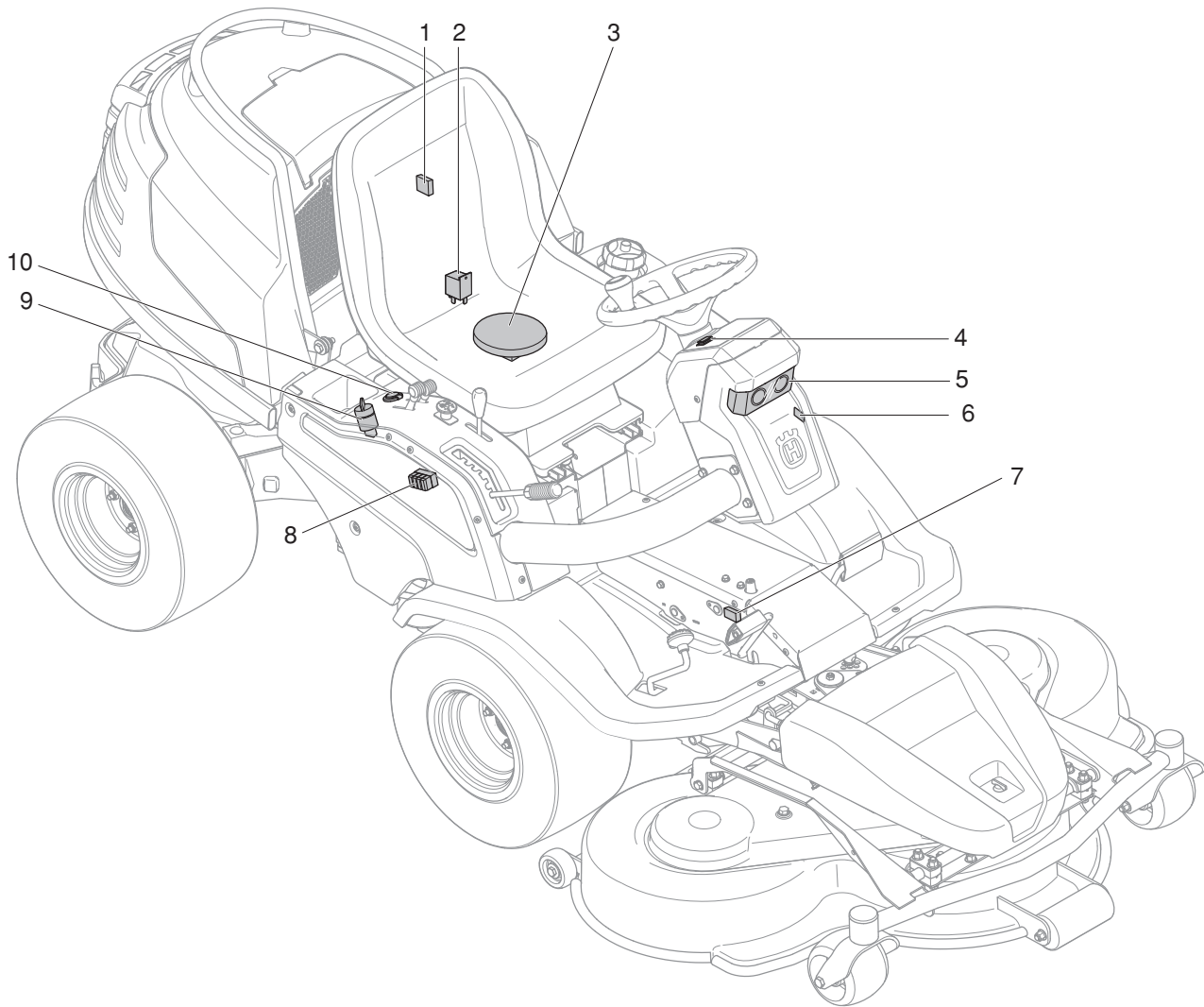

Numbers correspond to:

- 1 Main fuse 20 A
- 2 Start relay
- 3 Microswitch, seat
- 4 Switch for the lights
- 5 Lights
- 6 Counter
- 7 Microswitch, hydrostatic transmission
- 8 Fuse holder
- 9 Ignition lock
- 10 Power outlet

## Hydraulic System

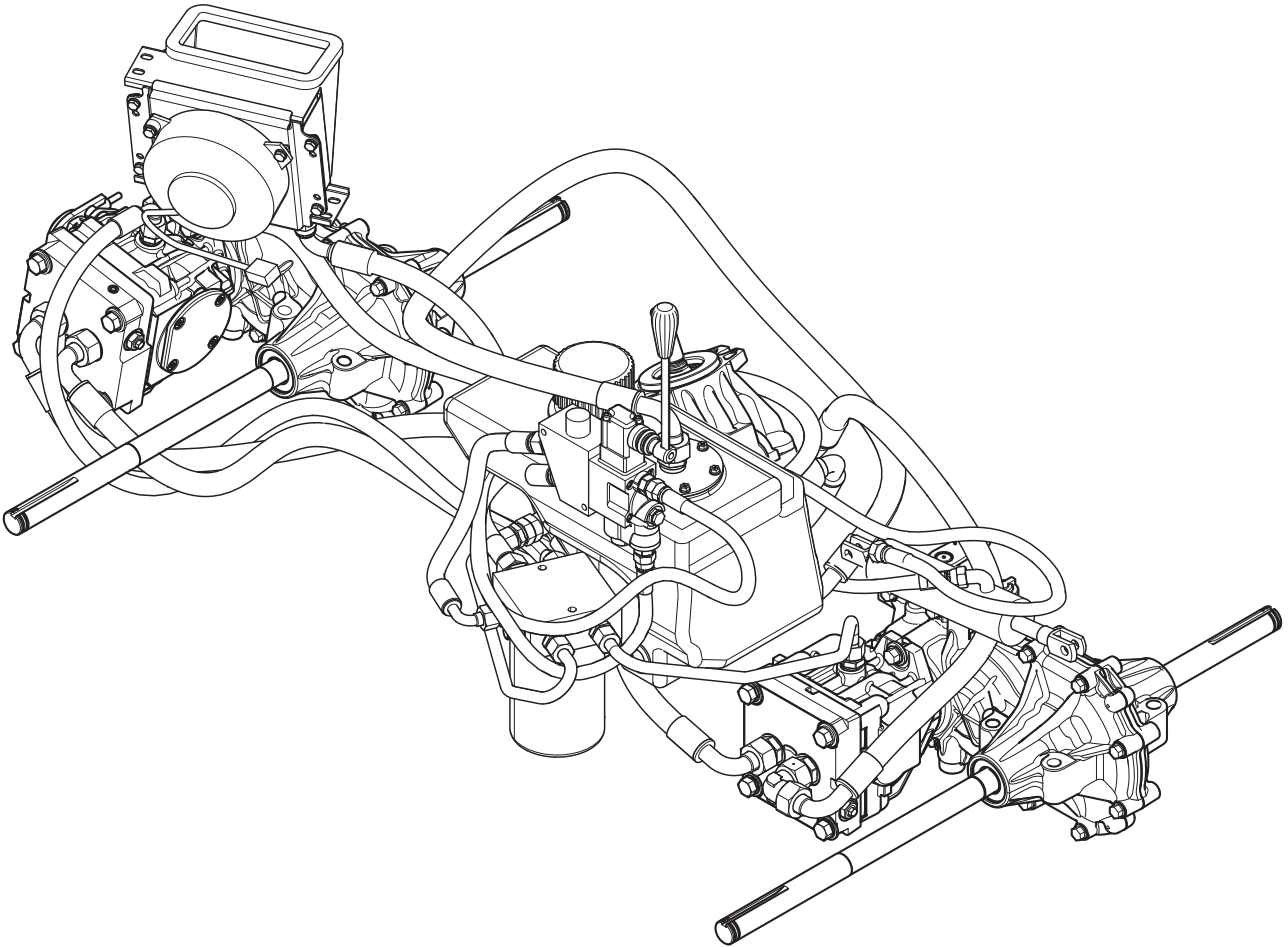

Keep the hydraulic system clean. Bear in mind that:

- Thoroughly clean before the top-up cap is opened or any connector loosened.
- Use clean containers when topping up the oil.
- Only use pure oil that has been stored in a sealed container.
- Do not reuse drained oil.
- Change the oil and filter according to the intervals specified in Maintenance Schedule.

In order for a hydraulic system to function without problem, it must be free from foreign objects. When used, the system produces particles, which can cause both wear and abnormal function. In order to remove these particles, the system contains filters. The filters are sized so as to capture the produced particles, but if contaminants are introduced from outside the system, the filters can quickly become clogged and fail to function as intended.

If there are contaminants in the system, further contamination will be produced in a self-propagating cycle. The result will be operating disruptions and much work to clean the system.

---

# Storage

---

## Winter storage

At the end of the season, or if the machine is going to stand idle for more than 30 days, it should immediately be made ready for storage. Fuel which is left to stand for long periods (30 days or more) can leave sticky deposits and interfere with the engine function.

Fuel stabiliser is an acceptable alternative to avoid tacky deposits during storage. If alkylate petrol (Aspen) is used stabiliser is not necessary since this fuel is stable. However, one should avoid changing from standard to alkylate petrol since sensitive rubber parts can harden.

Add stabiliser to the fuel in the tank or the storage container. Always use the mixing ratios indicated by the manufacturer. Run the engine for at least 10 minutes after adding the stabiliser. Do not empty the fuel tank and carburettor if stabiliser has been added.



**WARNING! Never store a machine with fuel in the tank indoors or in poorly ventilated spaces where fuel vapour can come in contact with open flames, sparks, or a pilot light such as in a boiler, hot water tank, clothes drier, etc. Exercise caution when handling fuel. It is highly inflammable, and careless use can cause serious injury and damage to property. Drain off the fuel in an approved container outdoors and well clear of naked flames. Never use petrol for cleaning purposes. Use degreasing agents and hot water instead.**

To prepare the machine for storage follow these instructions:

- 1 Carefully clean the machine, especially under the cutting unit. Touch-up paint damage to avoid rust.
- 2 Inspect the machine for worn or damaged parts and tighten loose screws and nuts.
- 3 Change the engine oil, and take care of the waste oil.
- 4 Empty the fuel tank. Start the engine and run it until the carburettor is emptied of fuel.
- 5 Remove the plugs and pour about a tablespoon of engine oil into each cylinder. Pull round the engine to distribute the oil and screw the plugs back on.
- 6 Grease all grease nipples, joints and axles.
- 7 Remove the battery. Clean it, charge it, and store it in a cool place.
- 8 Store the machine in a clean and dry place and cover it over for extra protection.

## Guard

There is a cover to protect your machine during storage or transport. Contact your dealer for a demonstration

## Service

Low season is the most suitable time to perform a service or overhaul of the machine in order to ensure high function safety during high season.

When ordering spare parts state your machine's purchase year, model, type, and serial number.

Always use genuine parts.

An annual check-up by an authorised servicing dealer is a good way to ensure that your ride-on mower performs at its best the following season.



# Technical data

<b>P524</b>	
<b>Dimensions</b>	
Unladen weight excluding cutting unit, kg/lb	412/908
Tyre dimensions	18 x 8,5 x 8
Air pressure, rear - front, kPa / bar / PSI	100/1,0/14,5
<b>Engine</b>	
Brand	Kawasaki, V-Twin
Model	FX691V-KME09023
Nominal engine output, kW (see note 1)	13,9
Displacement, cm <sup>3</sup> /cu.in	726/43,3
Fuel, minimum octane grade lead-free	95 (max. methanol 5%, max. ethanol 10%, max. MTBE 15%)
Tank volume, litres/USqt	22/23
Oil, API class CD or better	SAE 10W/40
Oil volume incl. filter	2,1/2,2
Oil volume excl. filter, litres/USqt	1,8/1,9
Max.motor speed, r/min	3000 ± 75
Starting	Electric starter
<b>Electrical system</b>	
Type	12 V, negative earthed
Battery	12 V, 24 Ah
Spark plug	NGK BPR4ES
Electrode gap, mm/inch	0,75/0,030
Main fuse, A	20
Bulbs, halogen	2x12V 20W
<b>Hydraulic System</b>	
Max. working pressure, bar / psi	120 / 1740
Hydraulic tank capacity, l/USqt	8/8,5
Hydraulic system capacity, l/USqt	13/13,7
<b>Transmission</b>	
Brand	Kanzaki KTM 23
Oil, class API SM, ACEA A3/B4	SAE 10W/50 Synthetic
Oil capacity gearbox front, l/USgal	0,9
Oil capacity gearbox rear, l/USgal	0,9
<b>Cutting unit</b>	
Model	Combi 103
	Combi 112
	Combi 122

Note 1: The power rating of the engine indicated is the average net output (at specified rpm) of a typical production engine for the engine model measured to SAE standard J1349/ISO1585. Mass production engines may differ from this value. Actual power output for the engine installed on the final machine will depend on the operating speed, environmental conditions and other values.

# Technical data

<b>Technical data concerning the cutting unit</b>			
<b>Cutting unit</b>	<b>Combi 103</b>	<b>Combi 112</b>	<b>Combi 122</b>
Cutting width, mm/inch	1030/41	1120 / 44.1	1220 / 48
Cutting heights, 7 positions, mm/inch	25-80/0.98-3.15	25-80/0.98-3.15	25-80/0.98-3.15
Blade length, mm/inch	383/15.1	420 / 16,5	454 / 17.9
Width, mm	1120 / 44.1	1220 / 48	1330 / 52,4
Weight, kg/lb	49/108	56 / 123.5	64 / 141
<b>Blade</b>			
Article number	5041904-10	5041878-10	5354294-10

<b>Technical specifications for sound and vibration levels</b>			
	<b>Combi 103</b>	<b>Combi 112</b>	<b>Combi 122</b>
<b>Noise emissions (see note 2)</b>			
Sound power level, measured dB(A)	99	99	102
Sound power level, guaranteed dB(A)	100	100	104
<b>Sound levels (see note 3)</b>			
Sound pressure level at the operators ear, dB(A)	86	85	89
<b>Vibration levels (see note 4)</b>			
Vibration level on the steering wheel, m/s <sup>2</sup>	1,7	1,7	1,7
Vibration level in the seat, m/s <sup>2</sup>	0,7	0,7	0,7

Note 2: Noise emissions in the environment measured as sound power ( $L_{WA}$ ) in conformity with EC directive 2000/14/EC.

Note 3: Noise pressure level according to ISO 5395. Reported data for noise pressure level has a typical statistical dispersion (standard deviation) of 1.2 dB(A).

Note 4: Vibration level according to ISO 5395. Reported data for vibration level has a typical statistical dispersion (standard deviation) of 0.2 m/s<sup>2</sup> (steering wheel) and 0.8 m/s<sup>2</sup> (seat).

**IMPORTANT!** When the service life of this product has been served and it is no longer used it should be returned to the dealer or to an applicable station for recycling.

**IMPORTANT!** We reserve the right to change specifications and designs without prior notice so as to implement improvements.

Note that no legal claims are valid on the basis of information in this manual.

Use only genuine parts for repairs. The warranty is not valid if non genuine parts are used.

# Technical data

## Dimensions

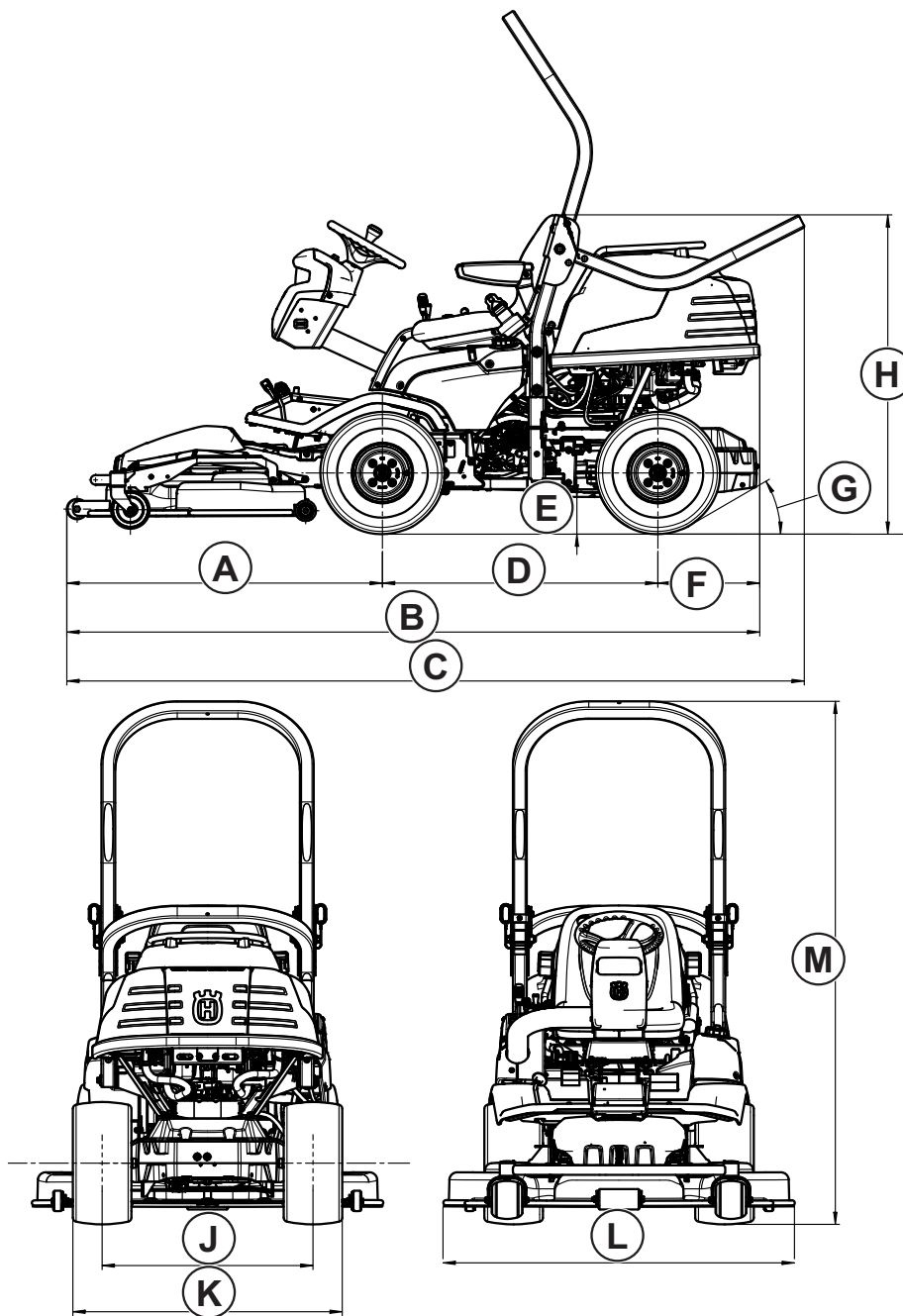

<b>A</b>	1145 mm	<b>G</b>	30°
<b>B</b>	2514 mm	<b>H</b>	1174 mm
<b>C</b>	2675 mm	<b>J</b>	765 mm
<b>D</b>	999 mm	<b>K</b>	977 mm
<b>E</b>	137 mm	<b>L</b>	1275 mm
<b>F</b>	370 mm	<b>M</b>	1924 mm

Dimensions including cutting deck are measured with cutting deck Combi 122 attached.

---

# Technical data

---

## EC Declaration of Conformity (Applies to Europe only)

Husqvarna AB, SE-561 82 Huskvarna, Sweden, tel: +46-36-146500, declares that the Husqvarna P524 ride-on mower, from 2011 serial numbers and onwards (the year is clearly stated on the rating plate followed by the serial number), complies with the requirements of THE COUNCIL'S DIRECTIVE:

of May 17, 2006 "relating to machinery" **2006/42/EC**.

of February 26, 2014 "relating to electromagnetic compatibility" **2014/30/EU**.

of May 8, 2000 "relating to the noise emissions in the environment" **2000/14/EC**.

Information regarding noise emissions and the mowing width, see Technical data

The following harmonised standards have been applied: **EN ISO 12100-2, ISO 5395**

Notified body: **0404, SMP Svensk Maskinprovning AB**, Box 7035, SE-750 07 Uppsala, has issued reports regarding the assessment of conformity according to annex VI of the COUNCIL'S DIRECTIVE of May 8, 2000 "relating to the noise emissions in the environment" 2000/14/EC.

The certificates have the numbers: **01/901/141, 01/901/142**

Huskvarna 19 September 2014



Claes Losdal, Development Manager/Garden Products

(Authorized representative for Husqvarna AB and responsible for technical documentation.)







**Original instructions**



**1153985-26**

**2017-10-12**