

Workshop manual
Rider 100-series

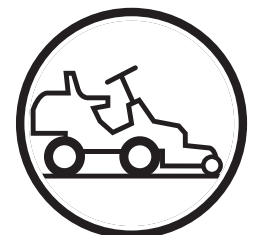

English

Workshop Manual

Rider 100-series

Contents

Safety Instructions	3	Wheels	16
General directions	3	Administration.....	16
Special directions	3	Design and Function	17
Special Tools	4	General.....	17
Technical Data 111 B5/111 B	5	Serial number	18
Dimensions.....	5	Engine	19
Engine	5	Steering.....	20
Electrical system	5	Drive	21
Noise emission and cutting width	5	Cutting unit	21
Noise levels	5	Repair Instructions	22
Vibration levels	5	Dismount the Engine	22
Transmission	6	Fuel tank.....	25
Cutting unit	6	Changing engine oil.....	26
Tightening torques.....	6	Checking and adjusting the steering cables... 26	
Play	6	Replacing steering cables	27
Technical Data 112 C5/112 C	7	Removing/fitting steering shaft.....	28
Dimensions.....	7	Removing/fitting cable pulley.....	29
Engine	7	Checking and adjusting brake cable	30
Electrical system	7	Checking and adjusting gear control	31
Noise emission and cutting width	7	Checking and adjusting clutch.....	31
Noise levels	7	Checking and adjusting accelerator	32
Vibration levels	7	Replacing articulated steering bearings	32
Transmission	8	Removing the pivoting rear axle.....	36
Cutting unit	8	Replacing pendulum shaft bushings	37
Tightening torques.....	8	Replacing bearings in articulation unit belt pulleys...37	
Play	8	Assembling pivoting rear axle	38
Technical Data 115 C5/120 C	9	Replacing hydrostatic cable	39
Dimensions.....	9	Replacing brake cable.....	42
Engine	9	Replacing belt 4, as far as cutting unit	43
Electrical system	9	Replacing belt 3, cutting unit drive	44
Noise emission and cutting width	9	Removing the cutting unit.....	46
Noise levels	9	Service position for cutting unit	47
Vibration levels	9	Assembling cutting unit	47
Transmission	9	Removal of blades and blade housing	48
Cutting unit	10	Grinding and balancing blades.....	49
Tightening torques.....	10	Electrical System	50
Play	10	Wiring diagram	50
Delivery and Dealer Service	11	Electrical system components.....	51
After the first 8 hours	11	Microswitch, seat.....	51
Dealer service	11	Microswitch, cutting unit	51
Service schedule	12	Microswitch, pedal carrier.....	51
Delivery Measures	13	Microswitch, pedal carrier.....	51
To our dealers.....	13	Ignition and starter switch.....	52
Packaging and unpacking	13	Main fuse.....	52
Parts packed with the Rider	13		
Battery	14		
Steering wheel.....	15		
Checking engine oil level.....	15		

Safety Instructions

General directions

This workshop manual is written for personnel with a general knowledge of repairing and servicing Rides.

The workshop where the Rider is to be repaired must be equipped with safety devices in accordance with local bylaws.

No one may repair the Rider without first reading and understanding the content of this workshop manual.

This machine has been tested and approved only together with the equipment supplied or recommended by the manufacturer.

This Workshop Manual contains the following warning boxes in relevant places.

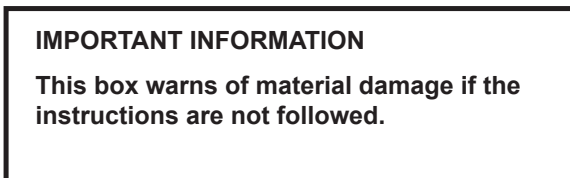
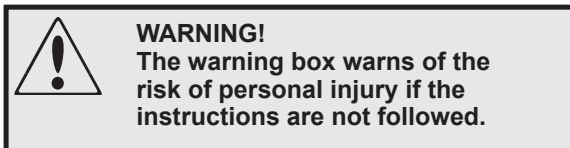

Special directions

The fuel used in the Rider has the following hazardous properties:

- The fluid and its vapor are toxic.
- Can cause eye and skin irritation.
- Can cause respiratory problems.
- Highly flammable.

When using compressed air, do not direct the air jet toward your body. Air can penetrate into the blood circulation, which means mortal danger.

Use eye protection when working on tensioned springs.

Use ear protection during testing.

During testing, do not touch the muffler before it has cooled down. Risk of burns. This is especially true if the Rider is equipped with a catalytic converter. The lining on and in the catalytic converter element is toxic for consumption. Use protective gloves when working on the catalytic converter/muffler.

The blades are sharp and can give cut injuries. Use protective gloves when handling the blades.

Use eye protection when working on the cutting unit. The belt tensioning spring can break, fly off and could cause personal injury.

Use eye protection while you are working with the battery. Take care when handling battery acid. Acid on skin can cause serious burns. In the event of spillage on the skin, wash immediately with water. Acid in eyes can result in blindness, seek medical aid.

Be careful when servicing the battery. Explosive gases are formed in the battery. Never carry out service on the battery while smoking or in the vicinity of naked flames or sparks. The battery can then explode and cause serious injury.

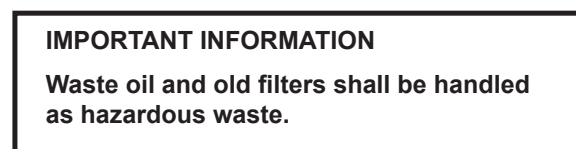

Special Tools

The following special tools are used when working on the Rider.
Special tools for engine and transmission can be found in the respective workshop manual.

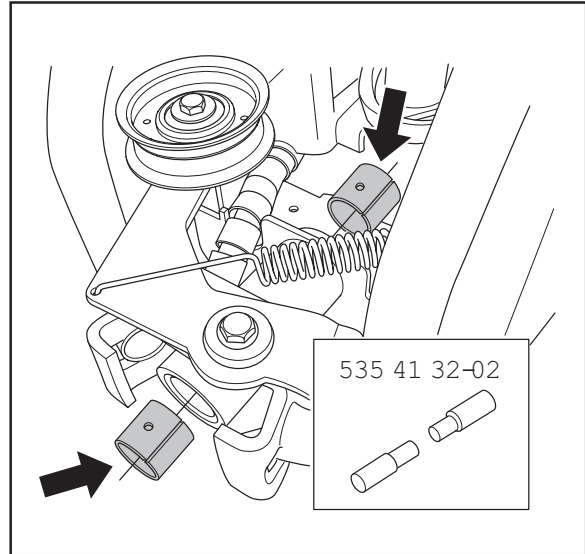
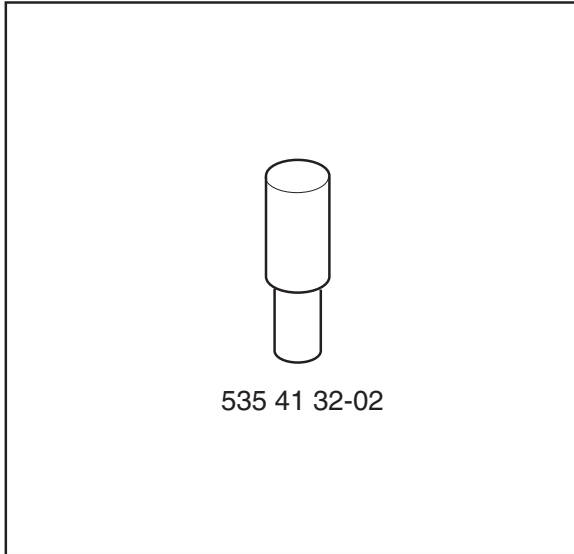

535 41 32-02 Mandrel for assembling the bushings on the swing axle.

Technical Data

	Rider 111B5	Rider 111B
Dimensions		
Length without cutting unit, mm/ft	1734/5.69	1734/5.69
Length with cutting unit, mm/ft	2100/6.89	2100/6.89
Width without cutting unit, mm/ft	785/2.56	785/2.56
Width with cutting unit, mm/ft	883/2.90	883/2.90
Height, mm/ft	1084/3.56	1084/3.56
Service weight with cutting unit, kg/lb	165/364	165/364
Wheelbase, mm/ft	800/2.62	800/2.62
Tire dimension	155/50-8	155/50-8
Air pressure rear - front, kPa (bar/PSI)	60 (0.6/8.5)	60 (0.6/8.5)
Max. permitted slope	10°	10°
Engine		
Make/Model	Briggs & Stratton/2158	Briggs & Stratton/2158
Rated output, kW (see note 1)	6.8	6.8
Stroke, cm ³ /cu.in	344/21	344/21
Max. engine speed, rpm	3000 ± 100	3000 ± 100
Fuel, minimum octane rating unleaded	85	85
Volume, fuel tank, liters	2.65	2.65
Oil, grade SJ-CF	SAE 5W/30 or SAE 10W/30	SAE 5W/30 or SAE 10W/30
Oil tank capacity, liters/USqt	1.4/1.5	1.4/1.5
Start	Electric starter	Electric starter
Electrical System		
Type	12V, negative ground	12V, negative ground
Battery	12V, 20 Ah	12V, 20 Ah
Spark plug	Champion QC12YC	Champion QC12YC
Electrode gap, mm/inch	0.75/0.030	0.75/0.030
Main Fuse	Flat pin, 15 A.	Flat pin, 15 A.
Noise emissions and cutting width (see note 2)		
Noise power level, measured dB(A)	98	98
Noise power level, guaranteed dB(A)	99	99
Cutting width, cm/inch	85/33.5	85/33.5
Noise levels (see note 3)		
Noise pressure level at user's ear, dB(A)	86	86
Vibration levels (see note 4)		
Vibration level in steering wheel, m/s ²	2.4	2.4
Vibration level in seat, m/s ²	0.7	0.7

Transmission	Rider 111B5	Rider 111B
Make	Peerless MST 205	Hydrogear T2
Oil, grade SF-CC	SAE 80W/90	SAE 20W/50
Number of forward gears	5	-
Number of reverse gears	1	-
Forward speed, km/h	0-7	0-7
Reverse speed, km/h	0-3	0-5

Cutting unit

Type	BioClip unit	BioClip unit
Cutting heights, 5 positions, mm/inch	25-70 / 1-2 3/4	25-70 / 1-2 3/4
Blade length, mm/inch	430/17	430/17

Note. 1: The power rating of the engine is the average net output (at the specified rpm) of a typical production engine of the model, measured to SAE standard J1349/ISO1585. Mass production engines may differ from this value. Actual power output for the engine installed in the final machine will depend on the operating speed, environmental conditions and other variables.

Note. 2: Emission of noise to the surroundings measured as sound power (LWA) in accordance with the EU directive 2000/14/EC.

Note. 3: Sound pressure level according to EN 836. Reported data for the noise pressure level has a typical dispersion (standard deviation) of 1.2 dB(A).

Note. 4: Vibration level according to EN 836. Reported data for the vibration level has a typical dispersion (standard deviation) of 0.2 m/s² (steering wheel) and 0.8 m/s² (seat).

Tightening torques

Steering cable pulley	57-61 ft/lb (20-30 Nm)	14-21 lbft
Blade belt pulley	57-61 ft/lb (45-50 Nm)	32-36 lbft
Blade	57-61 ft/lb (45-50 Nm)	32-36 lbft
Belt tensioner	57-61 ft/lb (15-25 Nm)	10-18 lbft
Engine mounting screws	57-61 ft/lb (20-25 Nm)	14-18 lbft
Gearbox mounting screws	57-61 ft/lb (20-25 Nm)	14-18 lbft
Engine belt pulley	52 ft/lb (70 Nm)	50 lbft

Play

Clutch wire R111 B5:	8 -10 mm	(5/16" - 3/8")
Brake lever to stop R111 B:	0 - 1 mm	(0 - 0.040")
Brake lever R111 B:	7 - 9 mm	(1/4" - 3/8")
Brake wire R111 B/B5:	22¼" / 1 mm	(0.040")
Hydrostat pedal wire R111 B:	0 mm	

Technical Data	Rider 112C5	Rider 112C
Dimensions		
Length without cutting unit, mm/ft	1781/5.84	1781/5.84
Length with cutting unit, mm/ft	2100/6.89	2100/6.89
Width without cutting unit, mm/ft	797/2.61	793/2.60
Width with cutting unit, mm/ft	883/2.90	883/2.90
Height, mm/ft	1084/3.56	1084/3.56
Service weight with cutting unit, kg/lb	191/421	191/421
Wheelbase, mm/ft	800/2.62	800/2.62
Tire dimension	155/50-8	155/50-8
Air pressure rear - front, kPa (bar/PSI)	60 (0.6/8.5)	60 (0.6/8.5)
Max. permitted slope	10°	10°
Engine		
Make/Model	Briggs & Stratton/3115	Briggs & Stratton/3115
Rated output, kW (see note 1)	6.4	6.4
Stroke, cm ³ /cu.in	344/21	344/21
Max. engine speed, rpm	3000 ± 100	3000 ± 100
Fuel, minimum octane rating unleaded	85	85
Volume, fuel tank, liters	4	4
Oil, grade SJ-CF	SAE 10W/30	SAE 10W/30
Oil tank capacity, liters/USqt	1.4/1.5	1.4/1.5
Start	Electric starter	Electric starter
Electrical system		
Type	12V, negative ground	12V, negative ground
Battery	12V, 20 Ah	12V, 20 Ah
Spark plug	Champion XC92YC	Champion XC92YC
Electrode gap, mm/inch	0.75/0.030	0.75/0.030
Main Fuse	Flat pin, 15 A.	Flat pin, 15 A.
Noise emissions and cutting width (see note 2)		
Noise power level, measured dB(A)	99	99
Noise power level, guaranteed dB(A)	100	100
Cutting width, cm/inch	85/33.5	85/33.5
Noise levels (see note 3)		
Noise pressure level at user's ear, dB(A)	85	85
Vibration levels (see note 4)		
Vibration level in steering wheel, m/s ²	1.6	1.6
Vibration level in seat, m/s ²	0.7	0.7

Transmission	Rider 112C5	Rider 112C
Make	Peerless MST 205	Tuff Torq T36P
Oil, grade SF-CC	SAE 80W/90	SAE 20W/50
Number of forward gears	5	-
Number of reverse gears	1	-
Forward speed, km/h	0-8	0-8
Reverse speed, km/h	0-3	0-8
Cutting unit		
Type	Combi unit	Combi unit
Cutting heights, 5 positions, mm/inch	25-70 / 1-2 3/4	25-70 / 1-2 3/4
Blade length, mm/inch	430/17	430/17

Note. 1: The power rating of the engine is the average net output (at the specified rpm) of a typical production engine of the model, measured to SAE standard J1349/ISO1585. Mass production engines may differ from this value. The actual power of the engine mounted in the final product depends on operating speed, surroundings and other factors.

Note. 2: Emission of noise to the surroundings measured as sound power (LWA) in accordance with the EU directive 2000/14/EC.

Note. 3: Sound pressure level according to EN 836. Reported data for the noise pressure level has a typical dispersion (standard deviation) of 1.2 dB(A).

Note. 4: Vibration level according to EN 836. Reported data for the vibration level has a typical dispersion (standard deviation) of 0.2 m/s² (steering wheel) and 0.8 m/s² (seat).

Tightening torques

Steering cable pulley	57-61 ft/lb (28-32 Nm)	21-24 lbft
Blade belt pulley	57-61 ft/lb (45-50 Nm)	32-36 lbft
Blade	57-61 ft/lb (45-50 Nm)	32-36 lbf
Belt tensioner	57-61 ft/lb (15-25 Nm)	10-18 lbft
Engine mounting screws	57-61 ft/lb (20-25 Nm)	14-18 lbft (M8 8.8 = 24Nm)
Gearbox mounting screws	57-61 ft/lb (20-25 Nm)	14-18 lbft (M8 8.8 = 24Nm)
Engine belt pulley	52 ft/lb (70 Nm)	50 lbft

Play

Clutch wire R112C5:	4 - 6 mm	(0.16" - 0.23")
Brake lever to stop R112 C:	0 - 1 mm	(0 - 0.040")
Brake lever R112 C:	7 - 9 mm	(1/4" - 3/8")
Brake cable R112 C:	1 mm	(0.040")
Hydrostat pedal wire R112 C:	0 mm	

Technical Data**Rider 115C****Rider 120C****Dimensions**

Length with cutting unit, mm/ft	2290/7.52	2290/7.52
Width with cutting unit, mm/ft	990/3.25	1260/4.13
Height, mm/ft	1080/3.56	1080/3.56
Service weight with cutting unit, kg/lb	219/482.5	221/487.2
Wheelbase, mm/ft	845/2.77	845/2.77
Tire dimension	165/60-8	165/60-8
Air pressure rear - front, kPa (bar/PSI)	60 (0.6/8.7)	60 (0.6/8.7)
Max. permitted slope	10°	10°

Engine

Make/Model	Briggs & Stratton/4145	Briggs & Stratton/4195
Rated output, kW (see note 1)	9.5	11
Stroke, cm ³ /cu.in	500/30.5	500/30.5
Max. engine speed, rpm	3000 ± 100	2900 ± 100
Fuel, minimum octane rating unleaded	85	85
Volume, fuel tank, liters	7	7
Oil, grade SJ-CF	SAE 10W/30	SAE 10W/30
Oil tank capacity, liters/USqt	1.4/1.5	1.4/1.5
Start	Electric starter	Electric starter

Electrical system

Type	12V, negative ground	12V, negative ground
Battery	12V, 21 Ah	12V, 21 Ah
Spark plug	Champion XC92YC	Champion XC92YC
Electrode gap, mm/inch	0.75/0.030	0.75/0.030
Main Fuse	Flat pin, 15 A.	Flat pin, 15 A.

Noise emissions and cutting width

(see note 2)

Noise power level, measured dB(A)	98	98
Noise power level, guaranteed dB(A)	99	98
Cutting width, cm/inch	95/37.4	95/37.4

Noise levels

(see note 3)

Noise pressure level at user's ear, dB(A)	85	84
---	----	----

Vibration levels

(see note 4)

Vibration level in steering wheel, m/s ²	1.6	1.6
Vibration level in seat, m/s ²	0.2	0.2

Transmission**Rider 115C****Rider 120C**

Make	Tuff Torq T36P	Tuff Torq T36P
Oil, grade SF-CC	SAE 20W/50	SAE 20W/50
Forward speed, km/h	0-10	0-10
Reverse speed, km/h	0-8	0-8

Cutting unit

Type	Combi unit	Combi unit
Cutting heights, 5 positions, mm/inch	25-75/1-3	25-75/1-3
Blade length, mm/inch	430/17	430/17

Note. 1: The power rating of the engine is the average net output (at the specified rpm) of a typical production engine of the model, measured to SAE standard J1349/ISO1585. Mass production engines may differ from this value. Actual power output for the engine installed in the final machine will depend on the operating speed, environmental conditions and other variables.

Note. 2: Emission of noise to the surroundings measured as sound power (LWA) in accordance with the EU directive 2000/14/EC.

Note. 3: Sound pressure level according to EN 836. Reported data for the noise pressure level has a typical dispersion (standard deviation) of 1.2 dB(A).

Note. 4: Vibration level according to EN 836. Reported data for the vibration level has a typical dispersion (standard deviation) of 0.2 m/s² (steering wheel) and 0.8 m/s² (seat).

Tightening torques

Steering cable pulley	57-61 ft/lb (28-32 Nm)	21-24 lbft
Blade belt pulley	57-61 ft/lb (45-50 Nm)	32-36 lbft
Blade	57-61 ft/lb (45-50 Nm)	32-36 lbft
Belt tensioner	57-61 ft/lb (15-25 Nm)	10-18 lbft
Engine mounting screws	57-61 ft/lb (20-25 Nm)	14-18 lbft (M8 8.8 = 24Nm)
Gearbox mounting screws	57-61 ft/lb (20-25 Nm)	14-18 lbft (M8 8.8 = 24Nm)
Engine belt pulley	52 ft/lb (70 Nm)	50 lbft

Play

Brake lever to stop R115 C/R120 C	0 - 1 mm	(0 - 0.040")
Brake lever R115 C/R120 C:	7 - 9 mm	(1/4" - 3/8")
Brake cable R115 C/R120 C:	1 mm	(0.040")
Hydrostat pedal wire R115 C/R120 C:	0 mm	

Dealer Service

8-hour service

1. Change the engine oil.

25-hour service

1. Change engine oil on top valve engine at high load and temperature.
2. Clean/Replace the air filter's precleaner (shorter intervals for dusty operating conditions.)
3. Change the air filter cartridge (25 hrs, 100 hrs if precleaner fitted. Shorter interval in dusty operating conditions.
3. Check the tire pressures.
4. Check the cutting unit (visual inspection).
5. Lubricate the belt adjuster.
6. Lubricate joints and shafts.
7. Adjust the brake.
8. Check the V-belts.
9. Clean the engine cooling air intake.
10. Check/clean the hydrostatic transmission's cooling fins.

50-hour service

1. Perform the 25-hour service as detailed above.
2. Change engine oil.
3. Check the transmission oil level.
4. Check/adjust the parking brake.
5. Check/adjust the throttle cable.
6. Clean the engine and transmission cooling fins.
7. Check/adjust the cutting unit settings.
8. Check the muffler and its spark arrester.

100-hour service

1. Perform the 25-hour service as detailed above.
2. Perform the 50-hour service as detailed above.
3. Replace the air filter's prefilter and paper filter.
4. Change fuel filter in the line.
5. Clean/change spark plug.

300-hour service

1. Inspect the machine. Reach agreement with the customer about which additional work should be carried out.
2. Perform the 25-hour service as detailed above.
3. Perform the 50-hour service as detailed above.
4. Perform the 100-hour service as detailed above.
5. Check the engine valve clearance.

At least once every season

1. Change engine oil (25/50 hours).
2. Replace the pre-filter in the air filter.
3. Replace the filter cartridge in the air filter.
4. Check/adjust the cutting unit settings.
5. Adjust the parking brake.
6. Inspect the flame proofing/spark arrester.
7. Clean/change spark plug.
8. Change fuel filter in the line.
9. Clean the engine and transmission cooling fins.
10. Check the engine valve clearance.
11. Check the fuel hose. Replace if necessary (this is done by an authorized servicing dealer)
12. Carry out the 300-hour service at an authorized servicing dealer.

Service Schedule

The following is a list of maintenance procedures that must be performed on the Rider. For those points not described in this workshop manual, refer to the operator's manual.

	Page	Daily maintenance before starting	25	50	100
Check the engine oil level	11	l			
Check the engine cooling air intake	-	t			
Check the fuel pump's air filter	-	t			
Check the steering wires	19	l			
Check the brakes	23	l			
Check the battery	10	l			
Check the safety system	-	t			
Check nuts and bolts	-	m			
Check for any fuel or oil leakage	-	m			
Clean around the muffler and the engine	-	m			
Change engine oil ¹⁾	19		l ¹⁾	l ¹⁾	
Clean the air filter and the prefilter ²⁾	-		m		
Check the cutting unit (visual inspection)	-		m		
Check the air pressure in the tires	12		l		
Lubricate the belt adjuster ³⁾	-		t		
Lubricate joints and shafts ³⁾	-		t		
Adjust the brakes	23		l		
Check the V-belts	-		m		
Check the transmission's cooling fins	-		m		
Clean the engine's cooling air intake	-		t		
Checking and adjusting the throttle cable	-			m	
Clean the engine and transmission cooling fins ^{2,4)}	-			m	
Check the muffler and its spark arrester	-			m	
Check and adjust the settings of the cutting unit	-			m	
Replace the air filter's prefilter and paper filter ²⁾	-				t
Change the fuel filter	-				t
Change spark plug	-				t

¹⁾First change after 8 hours. Change every 25 hours when under heavy loads and high temperature, otherwise ever 50 hours. ²⁾In dusty conditions, cleaning and replacement are required more often. ³⁾The Rider should be lubricated twice a week when used on a daily basis. ⁴⁾Performed by an authorized servicing dealer.

l = Described in this workshop manual.

m = Not described in this workshop manual.

t = Described in the operator's manual



WARNING!

Service procedures must not be conducted on the engine or cutting unit unless:

- The engine has been stopped.
- The ignition key has been removed.
- The ignition cable has been removed from the spark plug.
- The parking brake is engaged.
- The cutting unit has been disengaged.

Delivery Measures

To our dealers

A well-performed delivery service is the first step to a functioning aftermarket. It is in everybody's interest to have a functioning aftermarket:

- The customer is satisfied with their Rider. He/ she knows where to turn to get help if problems should arise.
- You will have a regular customer who will recommend you and your business to other potential customers.
- In this way, we can build our brand together and take a common responsibility for our products and customers.

Be thorough with your paperwork.

Complete the warranty and delivery documentation, etc., and make sure the customer is given the correct operator's manual for the machine.

Set up a customer database so that in the future you can see which machine the customer has, including all serial numbers. The database will be handy when ordering spare parts and in future marketing.

In conjunction with delivery, you should also provide the customer with the information required to handle and maintain the machine in a safe manner. Especially remember to inform the customer of:

- Safety regulations.
- Operating instruments. Putting in the neutral position (start lock function).
- Checking oil levels. Topping up oil and the type of oil required.
- First oil change after run-in period.
- The need for and advantages of following the service schedule and regularly leaving the Rider for service.
- What fuel to use.
- Mowing tips for a good result. Application for the Combi.
- What accessories are available for the type of Rider in question.
- Warranty conditions.
- Your business and who the customer should turn to if problems arise.

Packaging and unpacking

On delivery from the factory, the Rider is normally packed in special packing. This comprises a bottom board of wood with a top of sturdy cardboard, kept together with plastic film.

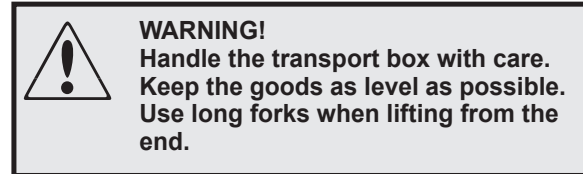

The bottom board has pallet feet and the goods can be handled with a normal forklift from the side. Two men should help the truck driver in order to keep the goods as level as possible. Lift and drive the truck with care.

Tear off the plastic film and lift off the pieces of cardboard.

The Rider then stands on the base with the brakes on and is secured with wooden blocks.

Check for any transport damage on the Rider once the packing is open. Report any damage to the carrier according to normal routines.

Do not return the packing.

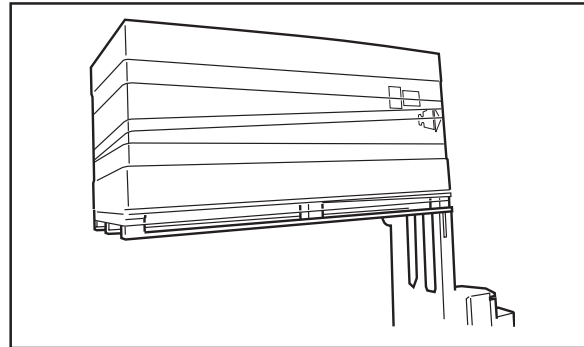

Lift from the end, see figure. Long pallet forks will be needed.

Parts packed with the Rider

The following components are contained in the transport box:

Quantity	Component
1 pc	Steering wheel with steering rod
1 pc	Pin steering wheel rod
1 pc	Operators manual
1 pc	Operating and Maintenance Instructions, Briggs & Stratton
1 pc	Seat with attachment details

Battery



WARNING!
Measures after contact with acid

- External:** Rinse with plenty of water.
Internal: Drink plenty of water or milk. Seek medical attention as quickly as possible.
Eyes: Rinse with plenty of water. Seek medical attention as quickly as possible.

The battery generates explosive gases. Sparks, flames and cigarettes must not occur in the close vicinity of the battery.

Starting the engine with a weak battery

If the battery is too weak to start the engine, it should be recharged. Charge the battery with max 3 Amps for 4 hours.

When the battery is fully charged, connect the red cable to the positive terminal (+terminal) of the battery and the black cable to the negative terminal (-terminal). Ensure that the red (+) cable is routed behind the black (-) cable.

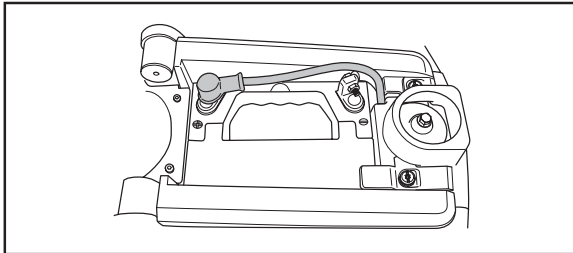

If jump leads are used for emergency starting, follow the procedure below:

Connecting the jump leads

IMPORTANT INFORMATION

Your Rider is equipped with a 12-volt system with negative ground. The other vehicle must also have a 12-volt system with negative ground. Do not use your Rider battery to start other vehicles.

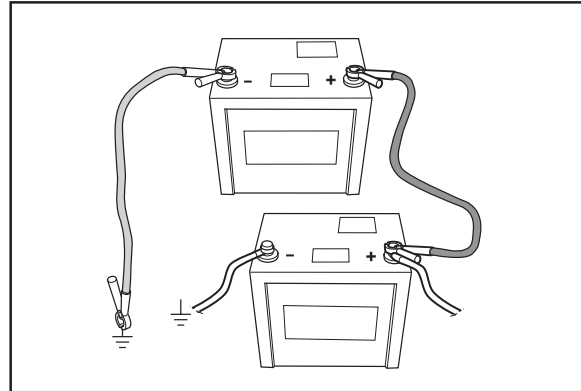

- Connect each end of the red cable to the POSITIVE pole (+) on each battery, exercise care not to short circuit any of the ends against the chassis.
- Connect one end of the black cable to the NEGATIVE pole (-) on the fully charged battery.
- Connect the other end of the black cable to a good CHASSIS EARTH, away from the fuel tank and the battery.

To remove cables, reverse order

- Remove BLACK cable first from chassis and then from the fully charged battery.
- Finally the RED cable from both batteries.

Steering Wheel

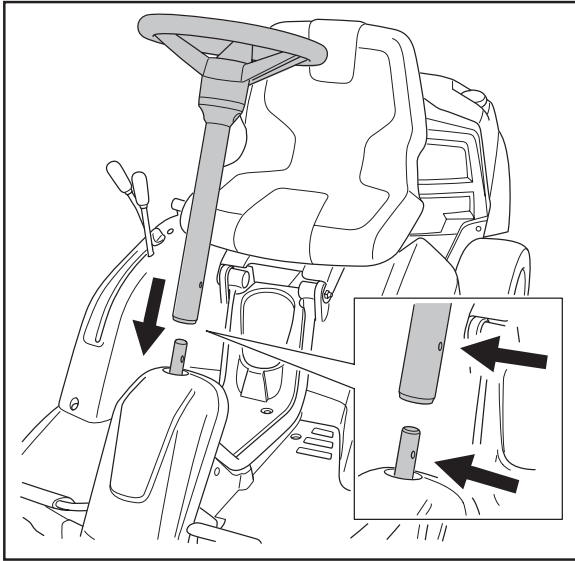

- 1 Fit the steering wheel with steering column tube onto the steering column. Ensure the holes are aligned.

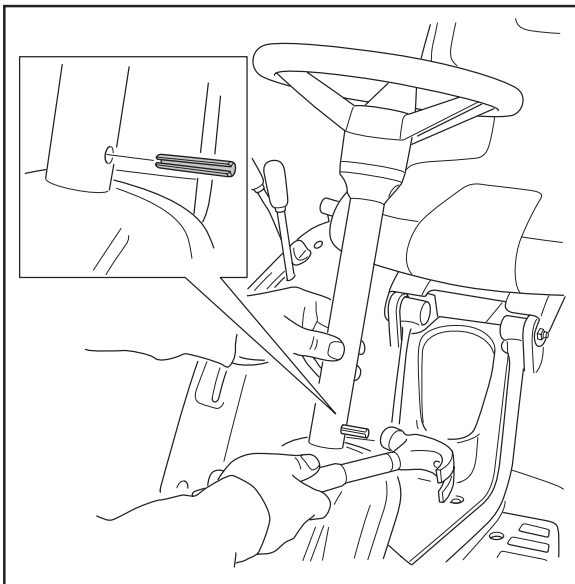

- 2 Fix the steering wheel by punching the pin in with a hammer.

Checking the engine's oil level.

Check the engine oil level when the Rider is standing on a flat surface with the engine turned off.

Raise the engine cover.

Loosen the dipstick, pull it up and wipe it off.

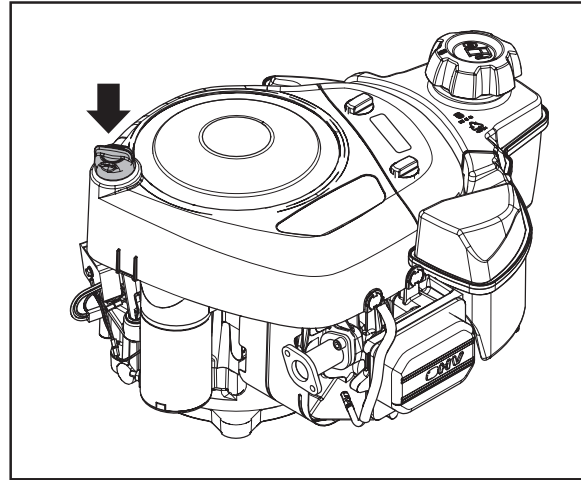

The dipstick should be **completely screwed down**.

Pull up the dipstick and check the engine oil.

The oil level should be between the markings on the dipstick. If the level is approaching the ADD mark, top up the oil to the FULL mark on the dipstick.

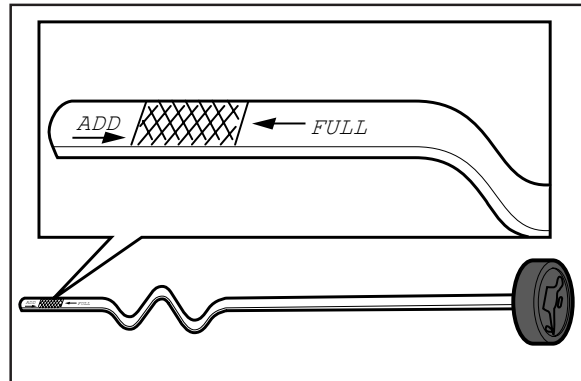

Fill oil into the same hole as the dipstick.

Fill slowly with oil. Tighten the dipstick properly before starting the engine. Start and run the engine at idling speed for around 30 seconds. Turn off the engine. Wait 30 seconds and then check the oil level. If necessary fill so that the oil comes up to the FULL mark on the dipstick.

First and foremost use synthetic engine oil class SJ-CF 5W/30 or 10W/30 for all temperature ranges. Mineral oil SAE30, class SF-CC can be used at temperatures > +5 °C (40 °F)

Do not mix different oil types.

Wheels

The tire pressure should be 60 kPa (0.6 bar / 8.5 PSI) on all wheels.

IMPORTANT INFORMATION

Different pressures in the front wheels will make the blades cut the grass at different heights.

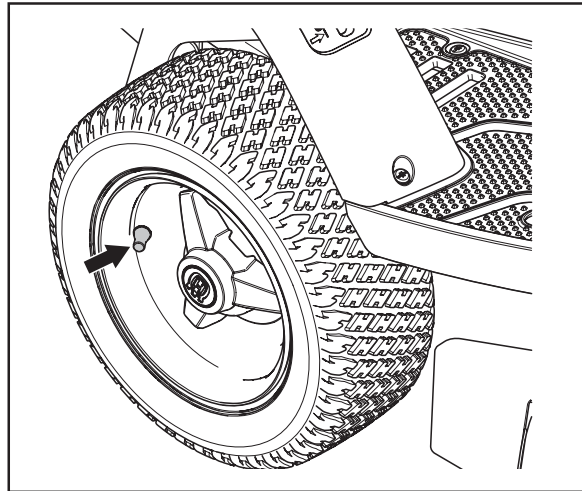

Administration

Complete the sales certificate, customer register, etc.

Do not forget to enter the serial number into the operator's manual and certify the delivery service in the service book.

PDI CHECKLIST



Completion of the Pre-Delivery Inspection is mandatory for the dealer to ensure the product is ready to be used when given to the end customer.

1	Visually inspect the product and its packaging for transportation damage and missing components.	<input type="checkbox"/>
TECHNICAL INSPECTION		
2	Check, charge and connect the battery. Measure battery voltage (should be above 12.7V before delivery).	<input type="checkbox"/>
3	Check and fill the steering wheel seal. Look for wear occasionally and check and adjust the tire pressure.	<input type="checkbox"/>
4	Install the cutting deck, adjust lift springs, adjust the cutting deck and the unit's height setting.	<input type="checkbox"/>
5	Check the oil level in the engine and if necessary fill up with recommended Husqvarna oil (SAE 10W/40 to be able to start and last).	<input type="checkbox"/>
6	Check the oil level in the transmission(s) and fill up with recommended Husqvarna oil (SAE 10W/40 for HD models and SAE 10W/40 for 2 HD models) if necessary.	<input type="checkbox"/>
7	Check the fuel system and fuel tank(s).	<input type="checkbox"/>
8	Fill with enough fresh fuel to be able to start and to test the engine on different RPM speeds. Always recommend Husqvarna fuel for best performance.	<input type="checkbox"/>
9	Check the lights and other electrical components.	<input type="checkbox"/>
10	Check for any leaks from the hydraulic and fuel system.	<input type="checkbox"/>
SAFETY INSPECTION		
11	Verify that the machine does not move in neutral and check forward and reverse drive on different speeds. Check the brake function.	<input type="checkbox"/>
12	Check the blade engagement and safety switches on rear, lift and drive/sharck pedal.	<input type="checkbox"/>
SERVICE & DELIVERY		
13	Inform the customer of the correct starting/stopping procedure, other safety features and necessary personal protective equipment.	<input type="checkbox"/>
14	Inform the end customer about recommended maintenance and remind the customer to book a time for recommended first service. (See maintenance plan in operator's manual).	<input type="checkbox"/>
15	Register the product in the Husqvarna Product Registration System.	<input type="checkbox"/>
Important to inform customer:		
16	Hand over the operator's manual to the end customer and instruct the customer to read it before use.	<input type="checkbox"/>
17	The transmission guarantee is only valid if the synchronization of the front and rear axles has been checked and adjusted in compliance with the service checklist. The system will be damaged if synchronization is not carried out.	<input type="checkbox"/>
18	Inform about the engine and other accessories.	<input type="checkbox"/>

NOTE! In the event of shipping products containing fuel tank batteries, the dealer is responsible to assure shipment of the product in accordance with applicable rules and regulations.

MODEL: _____ PNC: _____ SERIAL NUMBER: _____

DEALER NAME: _____ DATE: _____

Customer: _____

CUSTOMER SIGNATURE: _____ DATE: _____

The PDI document itself is not a proof of purchase. Make sure to keep the printed receipt (proof of purchase) together with the PDI document. In case of future defects please contact the dealer from which the product was bought.

Husqvarna © 2018. All rights reserved. Husqvarna is a registered trademark of Husqvarna AB. Husqvarna RIDERS is a registered trademark of Husqvarna AB.

Design and Function

General

Husqvarna Riders are a series of large capacity riders.

This manual applies to the smallest machines. All Riders have articulated steering for easy mowing around trees and other obstacles. They all also have front-mounted cutting units for controlled mowing and the best possible cutting results.

Husqvarna Riders are also equipped with accessories such as lawn rake and snow blade, making them flexible tools for all-year-round use.

Riders 111B5 and 112C5 are delivered with manual transmission, other Rider models are delivered only with hydrostatic transmission.

The Rider 100 series is equipped with a cutting unit with two blades, Combi.

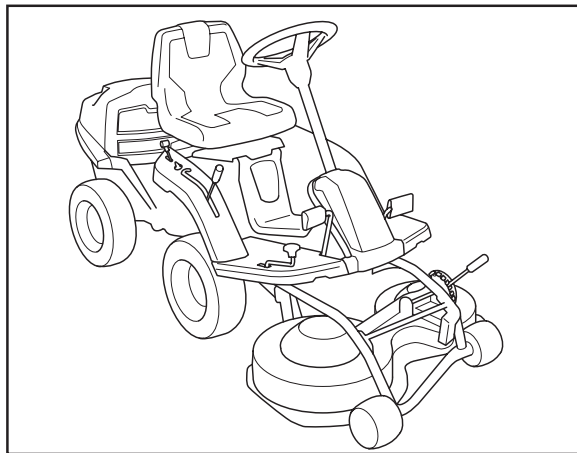

Serial number

The machine's serial number can be found on the printed plate (1) attached to the right below the engine cover. Stated on the plate, from the left, are:

- The machine's type designation (Model).
- The manufacturer's type number (PNC).
- The machine's serial number (Serial Number)

Please provide the type designation and serial number when ordering spare parts.

The engine's serial number is given on a bar code decal (2). It is placed on the top of the engine.

The text gives:

- Engine model
- Serial number
- Date of manufacture

Please provide the engine model and serial number when ordering spare parts.

The transmission's serial number is found on the bar code decal located on the front of the housing for the left-hand drive shaft.

Keep the information on the decal close at hand when ordering spare parts.

R112, R115, R120

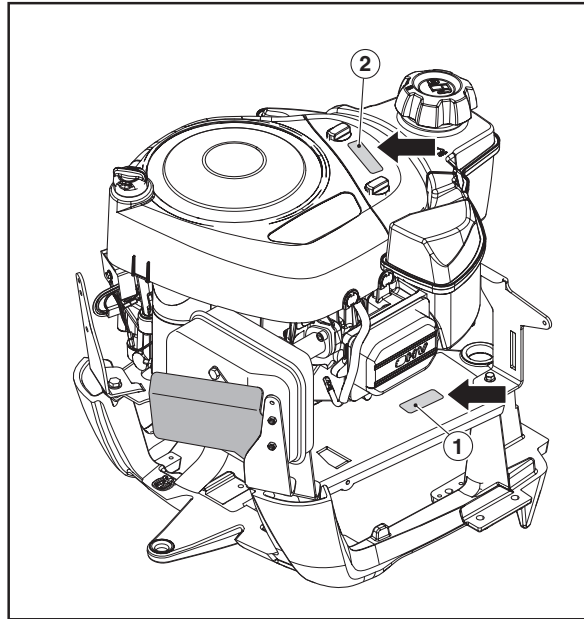

R111

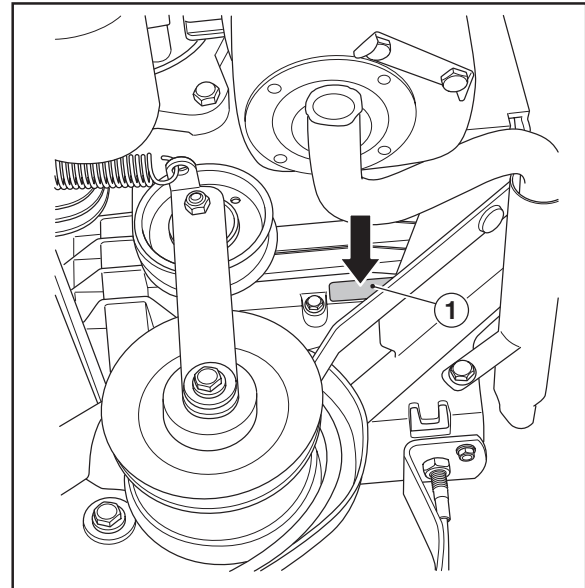

Engine

The Husqvarna Rider 100 series has a one-cylinder, air cooled engine from Briggs & Stratton. For information concerning the motors fitted to respective Rider models, see the Specification chapter.

Major engine repairs are not described in the workshop manual. Detailed information on adjustment and reparation of the engine is available in Briggs & Stratton's own manual. The manual can be ordered from an authorized servicing dealer.

See Technical Data for the engine model number.

It is important that only original spare parts are used to repair the engine. If other parts are used, the guarantee is invalidated.

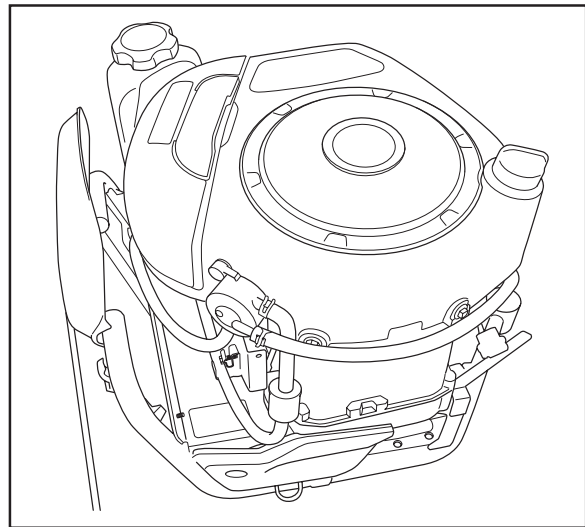

Steering

All Riders in the Rider range have articulated steering. The force from the steering wheel is transferred to the rear carriage via cables and a chain. This makes the Rider easy and precise to steer. A Rider mows easily around all the obstacles on the lawn.

The turning radius is very small thanks to the articulated steering.

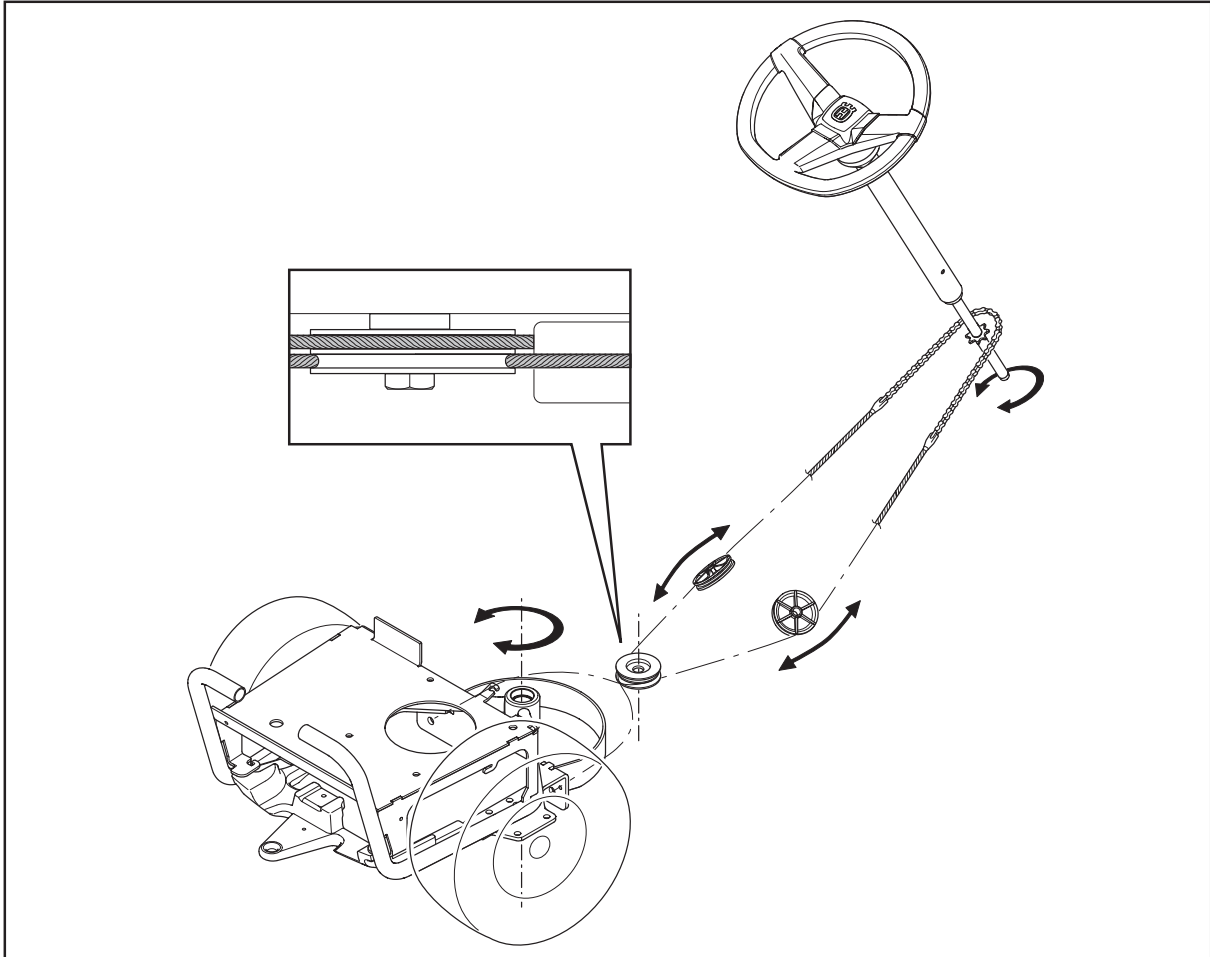

Outline sketch of the operation of the articulated steering.

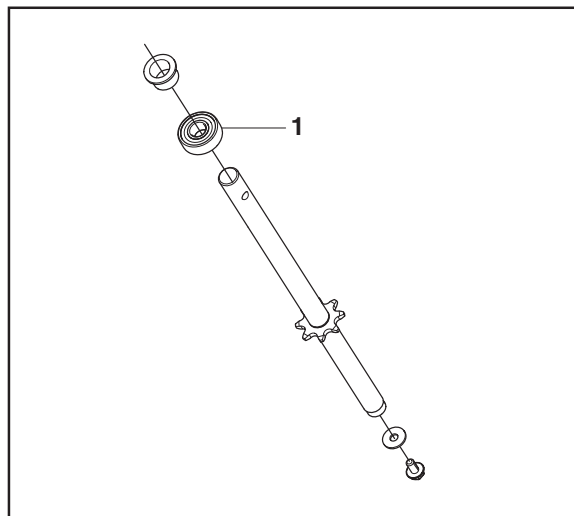

Rider machines have steering column mounted in ball bearings (1).

Drive

Rider 111B5 and 112 C5 has a manual gearbox with 5 forward gears, a neutral position and 1 backward gear. This gearbox is a so-called “inline” type, which means that changes can be made directly from neutral to fifth without stopping at each intermediate gear.

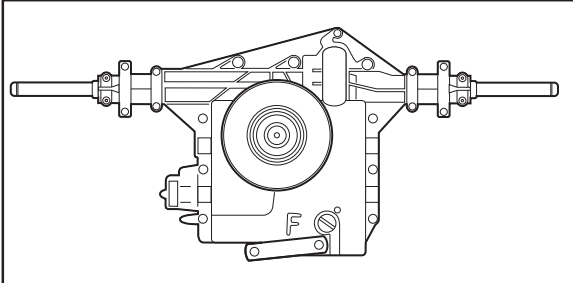

Manual gearbox to Rider 111B5.

The Rider 111 B, 112 C, 115 C and 120 C are equipped with hydrostatic transmission that provides the driver with full driving control. The speed is controlled variably using the pedals forward or reverse.

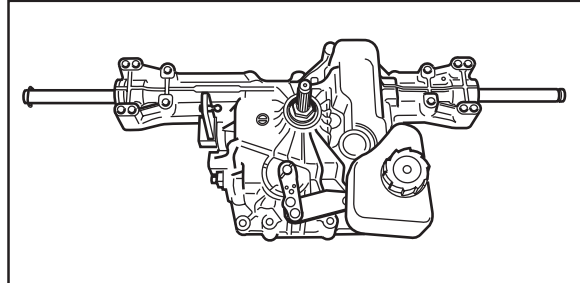

Hydrostatic transmission to Rider 111 B.

Cutting unit

The whole Rider range is equipped with front-mounted cutting unit to mow efficiently even in confined spaces.

The Rider 100 series has a cutting width of 850 mm (34") or 950 mm (38"), Combi.

The Combi-unit, equipped with a BioClip-plug, finely chops the cuttings to fertilizer. Without the BioClip-plug the unit works in the same way as a rear ejection unit.

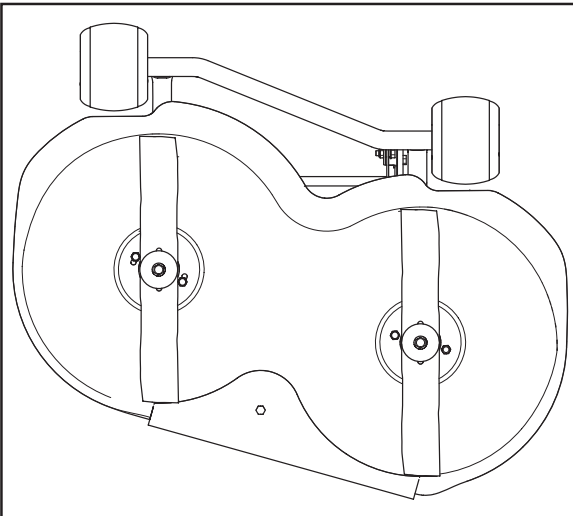

BioClip/Combi.

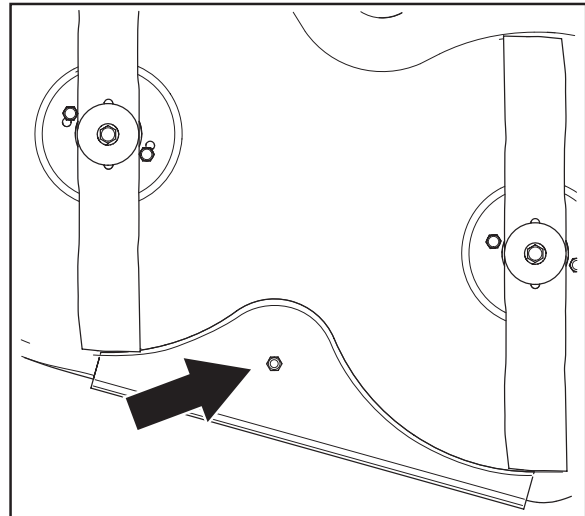

Removing the BioClip plug

Repair Instructions

Dismount the engine

The figures show a Rider 112C.

- 1 First disconnect the negative terminal on the battery and then the positive terminal.



IMPORTANT INFORMATION!

Hold the bolts so that the poles are not put under strain.

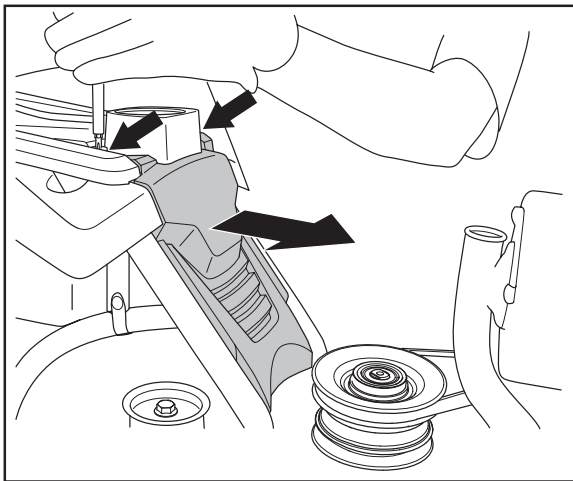

- 2 Remove the rear cover of the front carriage.

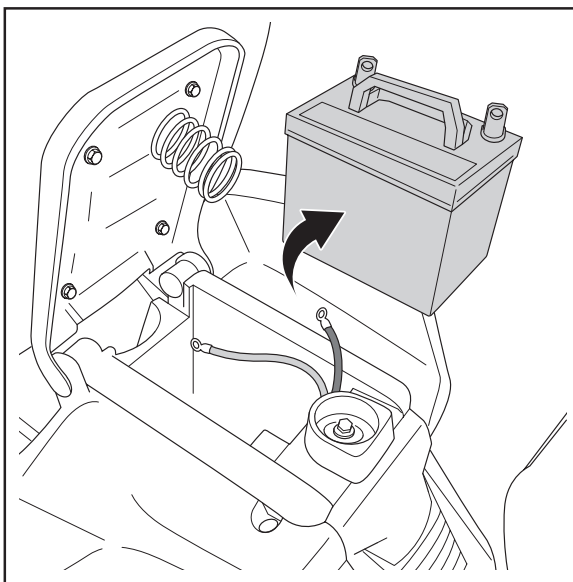

- 3 Lift out the battery.

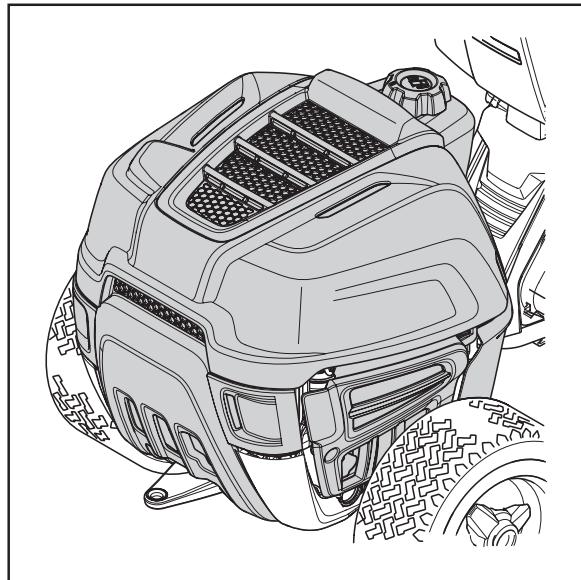

- 4 Remove the covers on the back of the machine, the side covers and the cover over the fuel tank.

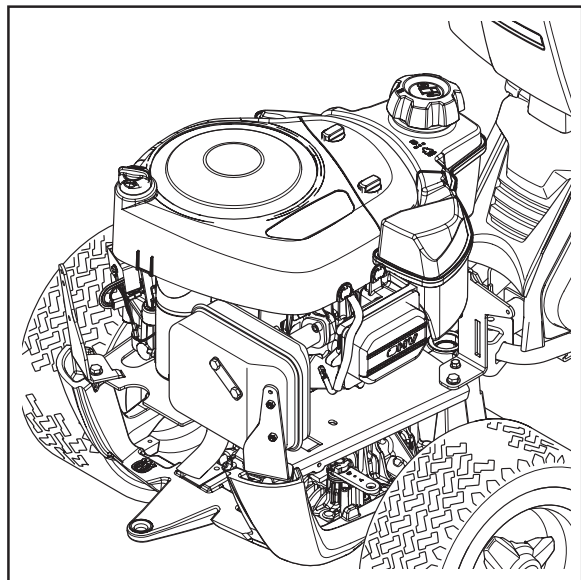

- 5 Place a suitable vessel underneath the fuel tank to collect the gasoline in.

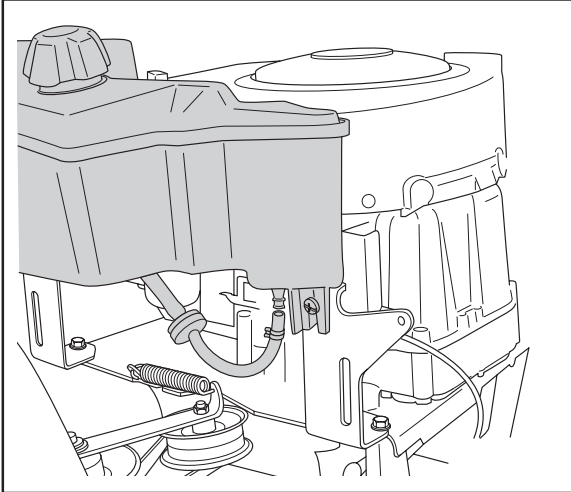

- 6 Remove the clamp and hose from the fuel tank and drain the fuel into the vessel. There are two fuel hoses on Rider 120C and 120S.

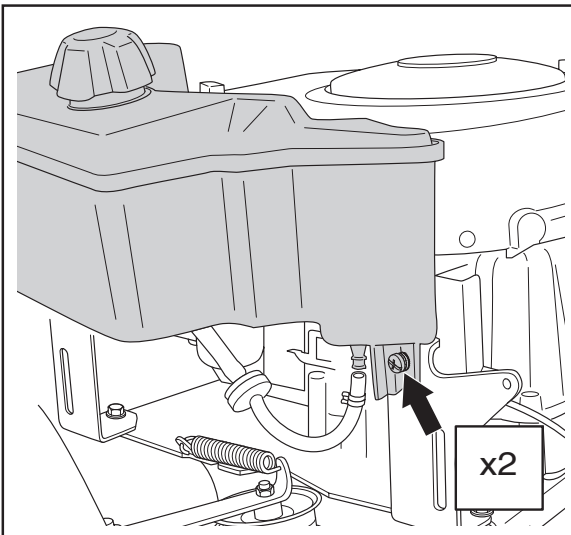

- 7 Unscrew the two screws and washers holding the fuel tank.

Save the washers for refitting the fuel tank!

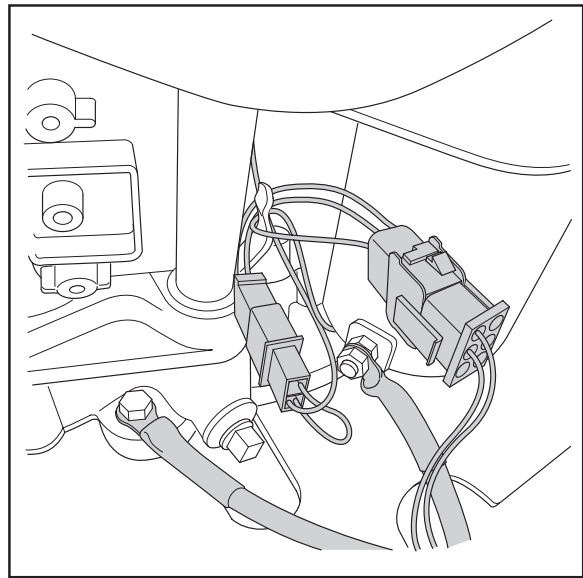

- 8 Disconnect the engine pin connector, the ground cable and the starter motor cable.

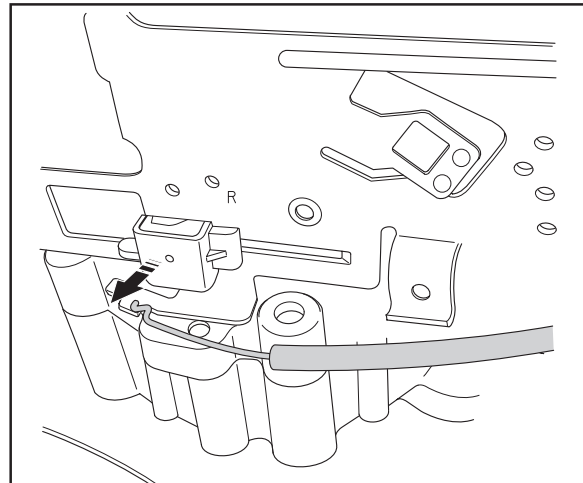

- 9 Disconnect the throttle cable.

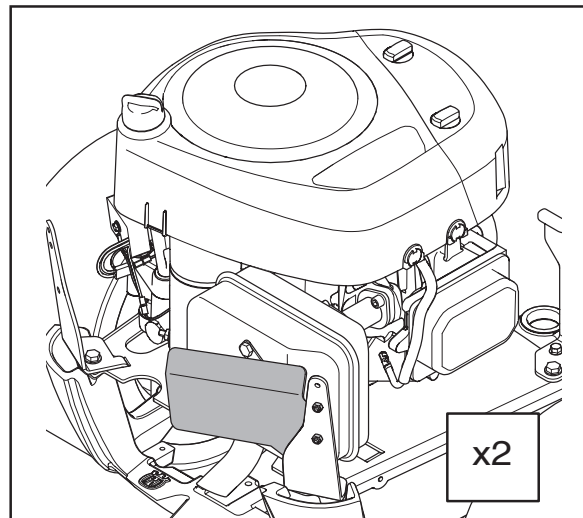

- 10 Unscrew the heat shield for the muffler.

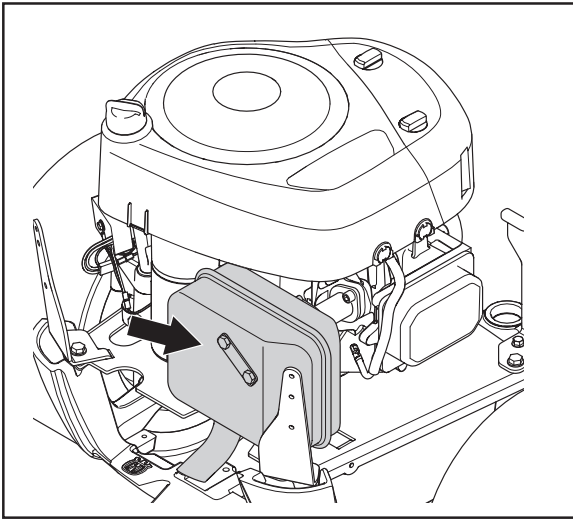

11 Unscrew the muffler.

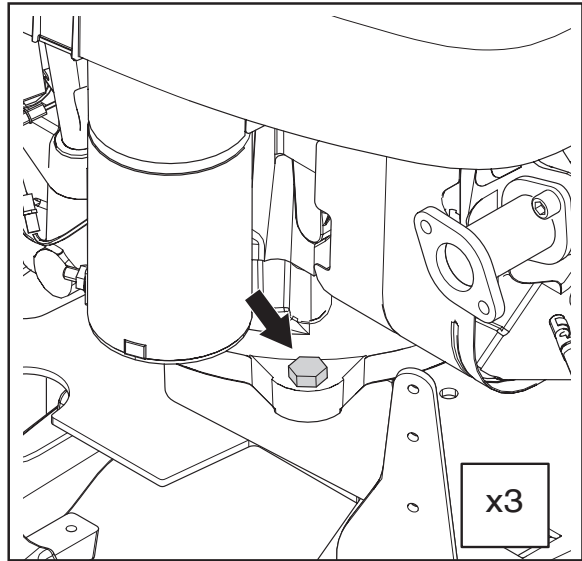

14 Unscrew the remaining 3 screws from the engine block.

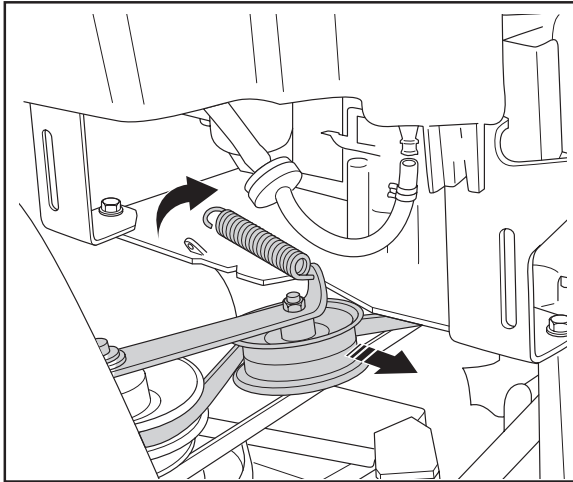

12 Unhook the spring on the drive belt pulley in the articulated unit and turn the belt tensioner to one side.

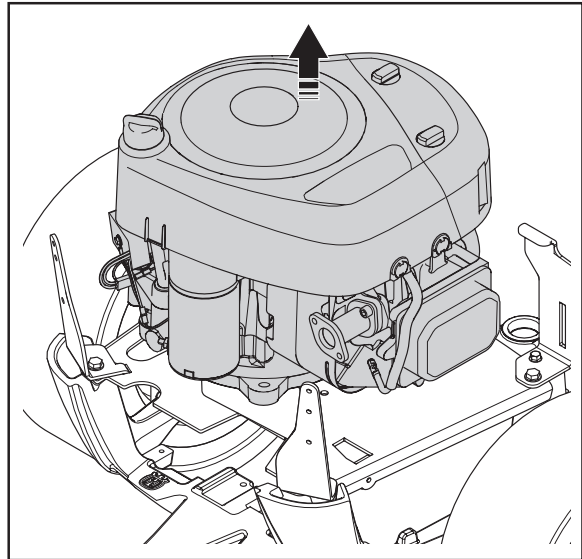

15 Lift off the engine.

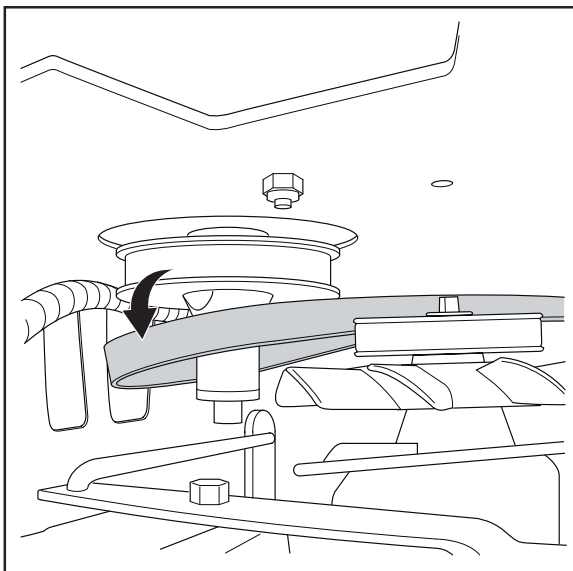

13 Loosen the drive belt from the pulley under the engine plate.

Assemble in reversed order.

Fuel tank

Removal



WARNING!
Gasoline is highly flammable and environmentally hazardous. Take great care to prevent fires and avoid spills.

- 1 Place a suitable vessel underneath the fuel filter to collect the gasoline in.

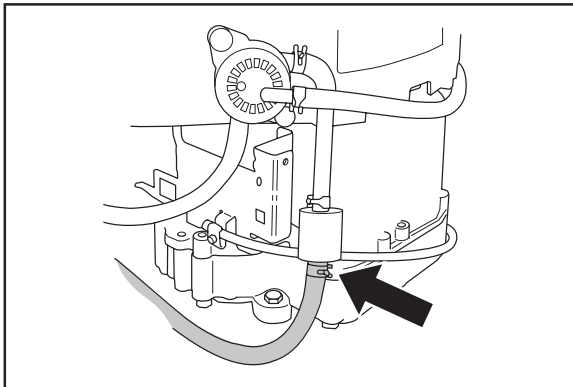

- 2 Empty the fuel tank by removing the hose and the hose clamp from the lower connection of the fuel filter. There are two fuel hoses on Rider 120C and 120S.

If draining the tank is not desired, the hose can be compressed with a locking welding pliers. Make sure to keep the end of the hose above the level in the tank from now on.

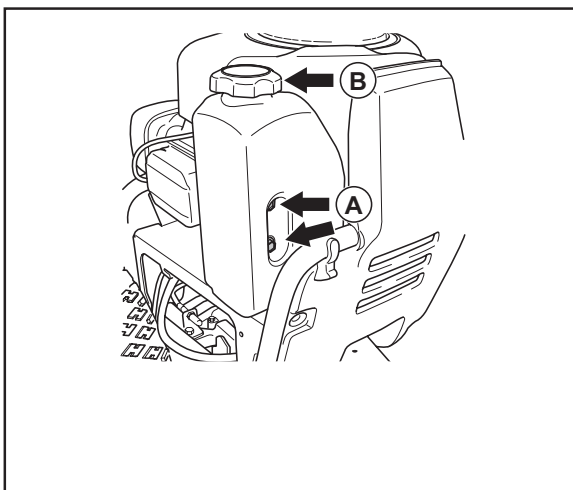

Rider 111/111B5

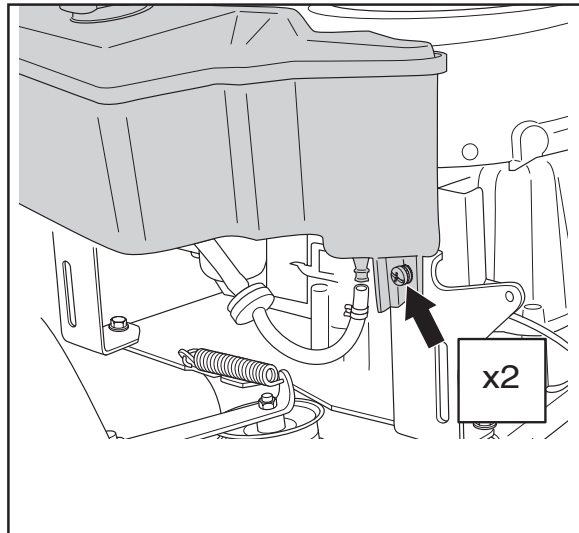

Rider 112/112C5, 115C/120C

- 3 Remove the two screws (1) holding the tank. Lower the tank and pull out the hose through the machine frame.

Assembly

- 1 It is easier to work if you empty the tank before assembly. Install the tank and secure it with the screws (1).
- 2 Put the hose in place and connect it to the fuel filter with a hose clip. Make sure the hose does not chafe.
- 3 Loosen the tank cap (2) and fill the tank with gasoline. Check for leakage.

Changing engine oil

For information about oil change intervals; see the "Service Schedule".



WARNING!
Engine oil can be very hot if it is drained directly after stopping the engine. Allow the engine to cool down first.

IMPORTANT INFORMATION

Used engine oil is a health hazard and must not be disposed of on the ground or into the environment; it should always be disposed of at an appropriate disposal site.

Avoid skin contact; wash with soap and water in case of spills.

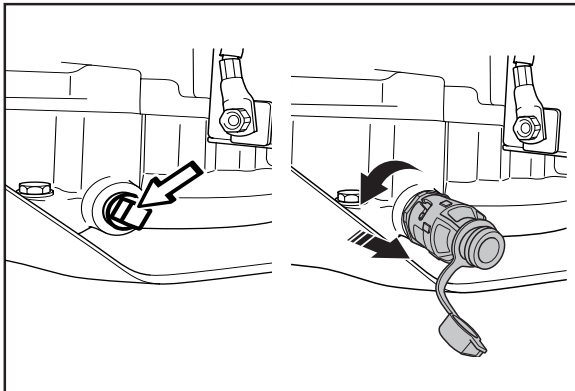

Oil drain plug

Tip! When draining the engine oil, fold a piece of cardboard and use it to guide the oil into the drainage container.

Place a container under the engine's oil drain plug.

Remove the dipstick and drainage plug. If equipped with a oil drain plug that can be opened by hand: Turn counterclockwise and pull out to open.

Let the oil run out into the container.

Fit the drain plug and tighten it.

Fill with oil up to the "FULL" mark on the dipstick. Oil is topped up through the same opening as the dipstick. See "Delivery measures\Checking the engine oil level" for the filling procedure. Use engine oil according to "Specifications".

Run the engine warm, then check that there is no leakage from the oil plug.

Checking and adjusting the steering cables

The steering is controlled with cables. These can stretch after a time, which means the steering settings can change.

Steering can be checked and adjusted in the following way:

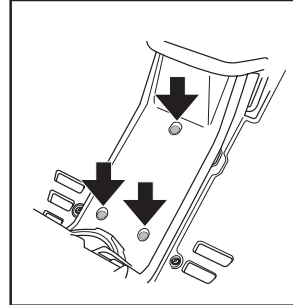

- 1 Remove the frame cover by loosening the screws. 3 pcs screws:

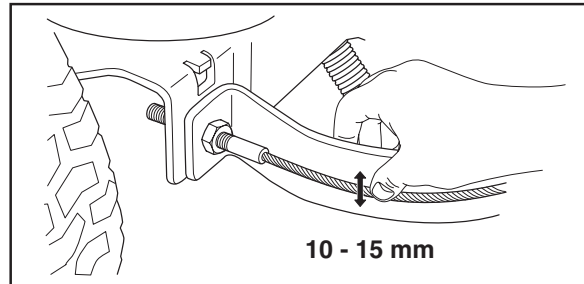

- 2 Check the tension of the steering cables. A correctly tensioned cable should be possible to move with your fingers 10-15 mm along the steering collar.

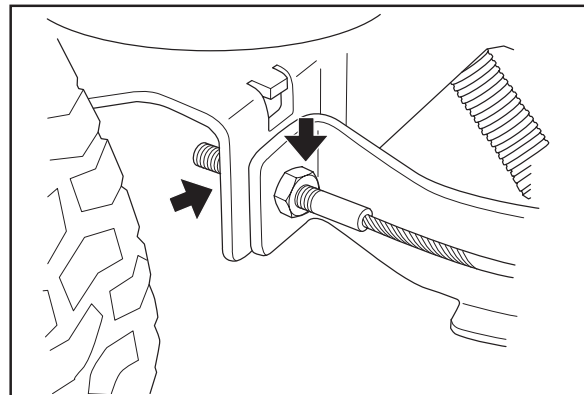

- 3 If necessary, the wires can be adjusted by tightening the adjuster nuts on each side of the steering collar. Do not overtension the cables. Hold the cable, for example using an adjustable wrench, so that it does not twist.

If you only tension one side the steering wheel's center position may change.

Check the wire tension as set out in point 2 after you have made the adjustment.

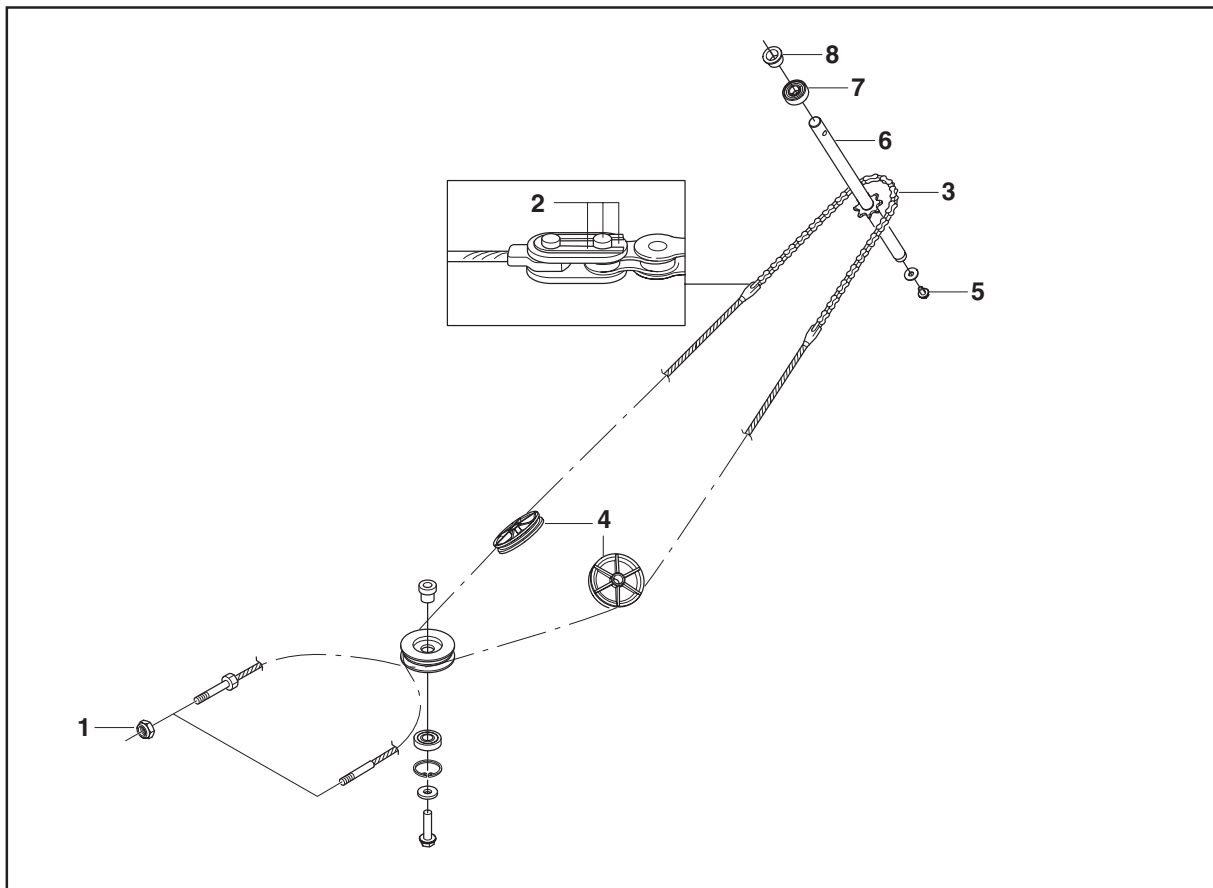

Replacing the Steering Cables

- 1 Loosen the rear fastening of the steering cables (1).

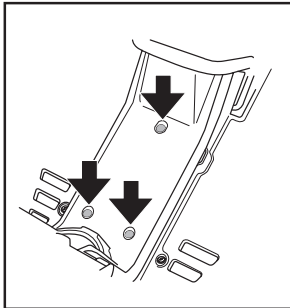

- 2 Remove the frame cover by loosening the screws. 3 pcs screws:
- 3 Remember the cable routing. Loosen the front attachment (2) of the steering cables at the steering chain (3), loosen the steering cable wheels (4) and pull the steering cables out through the frame.

Note. If the old cables are whole, the new ones can be attached to them as they are drawn out through the frame. The new cables will then automatically follow the correct route.

- 4 Ensure that the steering wheel is in the center position when the rear wheels are centered. Reset the chain on the steering column's sprocket or adjust the rear fixture (1) for the steering cables as needed.

Hold the cables with e.g. an adjustable wrench so they do not twist.

Check the cable tension when new cables are fitted (see "Checking and adjusting the steering cables").

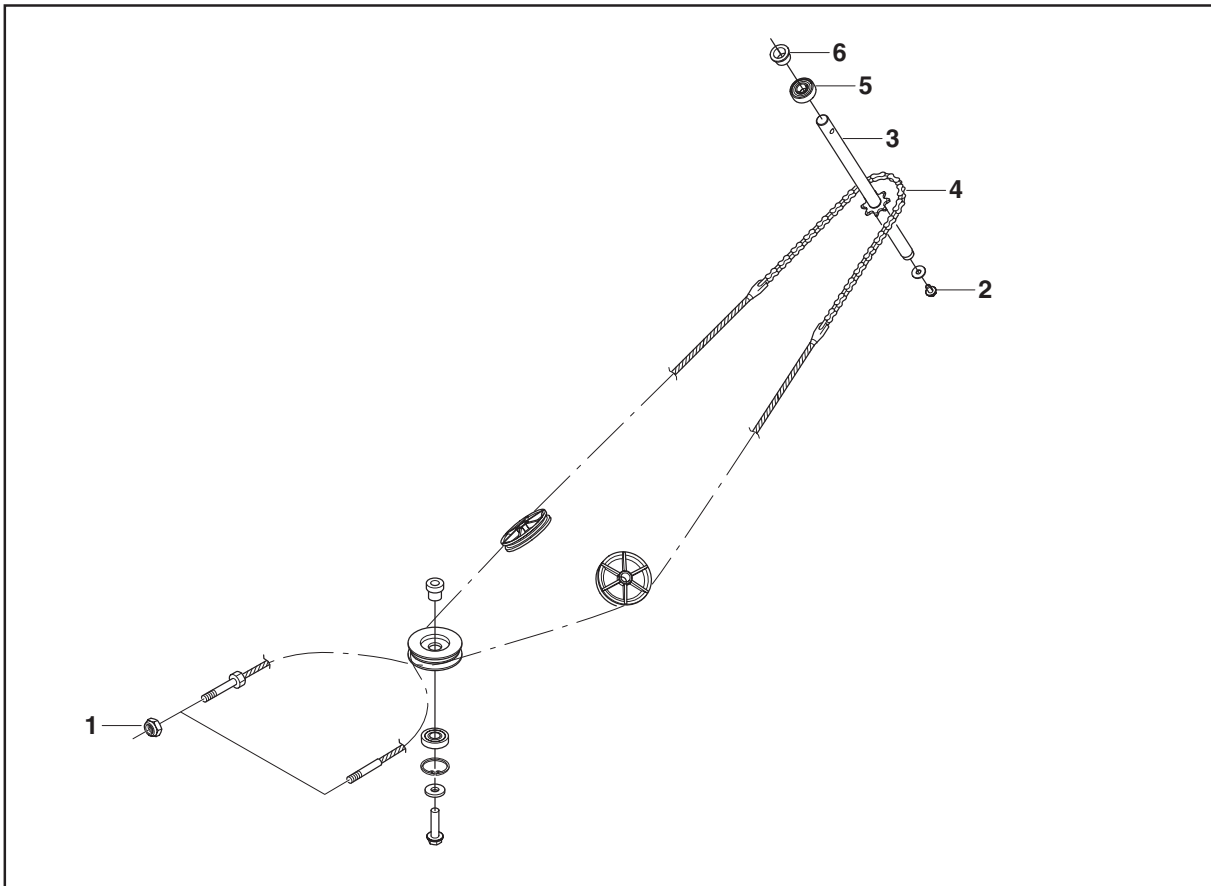

Removing/Fitting the Steering Shaft

- 1 Loosen the rear fastening of the steering cables (1).

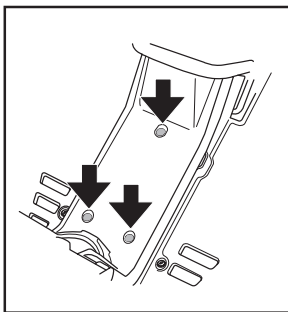

- 2 Remove the frame cover by loosening the screws. 3 pcs screws:
- 3 Remove the steering wheel and steering wheel rod by punching the pin out with a mandrel, lift the steering wheel and steering wheel rod upwards.

- 4 Unscrew the screw (2) in the lower edge of the steering wheel rod.
- 5 Pull the steering wheel shaft (3) upwards and move the lower part of the shaft backwards to pull off the steering chain (4).
- 6 Move the upper bearing (5) upwards until it moves freely from the steering wheel shaft (3). If the bearing needs replacement, the bushing (6) must be tapped out of the bearing.
- 7 Remove the steering wheel shaft (3) in a downwards movement.
- 8 To assemble the steering shaft, follow the instructions in the reverse order.

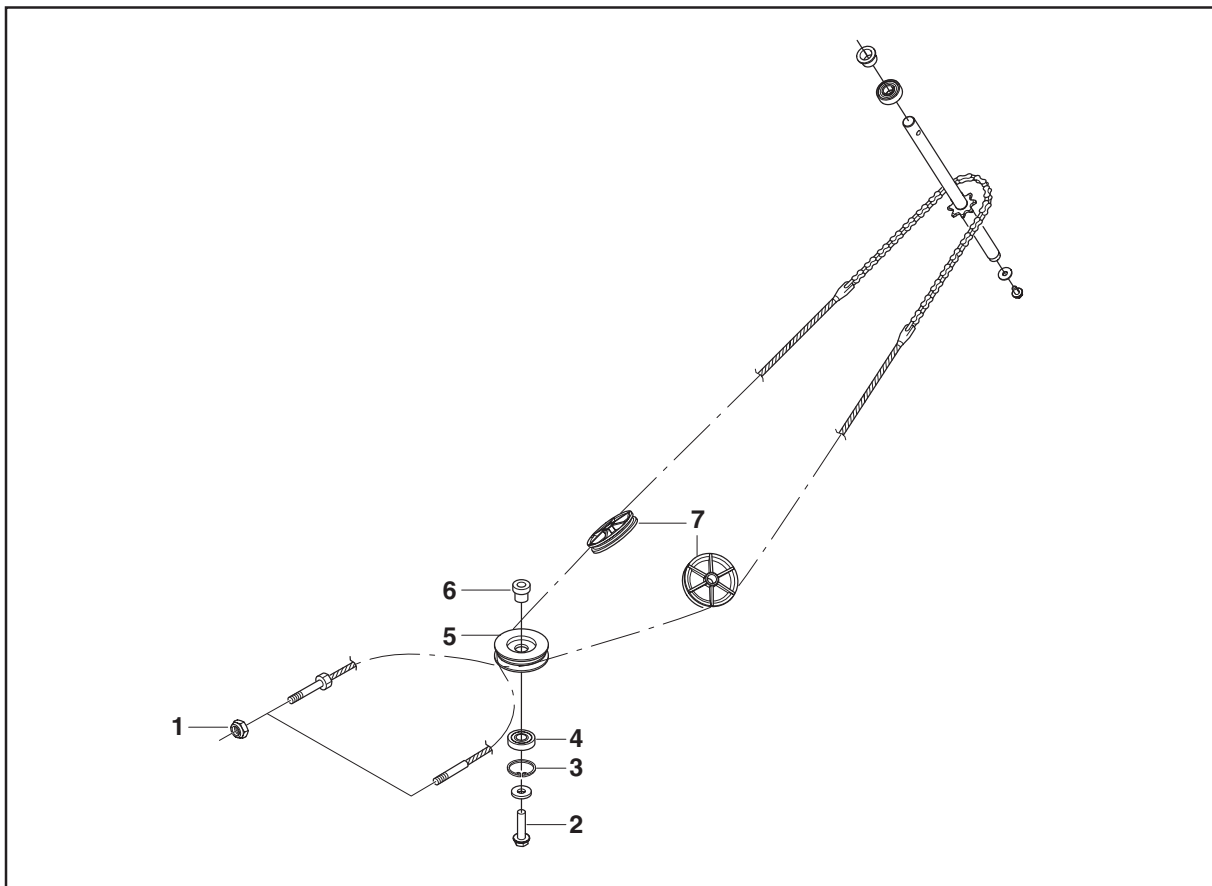

Removing/assembling the cable pulley

- 1 Loosen the rear fastening of the steering cables (1).
- 2 Remove the screw (2) and the cable pulley (5).
- 3 Remove the bearing circlip (3) and tap out the bearing (4).
- 4 Assemble the cable pulley in reverse order.

Bushing (6) is placed between the frame and the cable pulley.

Ensure that the cables are properly placed in the steering cable pulleys (7).

Ensure that the steering wheel is in the center position when the rear wheels are centered. Re-set the chain on the steering column's sprocket or adjust the rear fixture (1) for the steering cables as needed.

Hold the cables with e.g. an adjustable wrench so they do not twist.

After assembly, the cable tensioning must be checked (see "Checking and Adjusting the Steering Cables").

Checking and adjusting the brake cable

Rider 111B

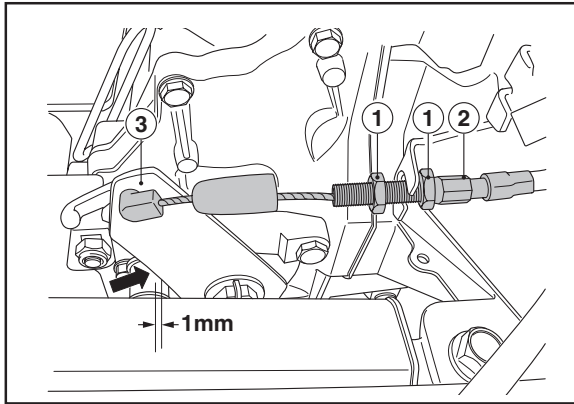

Ensure that the brake is properly adjusted by measuring the gap between the brake lever (3) and the sleeve behind it.

The gap should be 0.040"/1 mm when the brake is not applied.

- 1 Loosen the lock nuts (1).
- 2 Tension the cable with the adjustment screw (2) so that the gap between the brake lever and the sleeve is 0.040" / 1 mm.
- 3 Tighten the lock nuts (1) after adjustment. When the brake cable is adjusted, you should make sure that the brake lever does not have too much play. If the free movement of the lever exceeds 3/8" / 9 mm, this should be adjusted by tightening the nut on the brake lever.



WARNING!
A poorly adjusted brake can result in reduced braking ability.

Rider 111 B5/112 C5

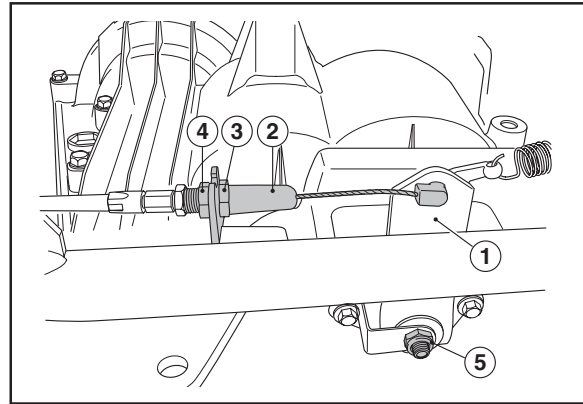

The brake is properly adjusted when the brake lever (1) is completely vertical. If it is not, adjust the brake wire by pulling the rubber sleeve (2) aside, loosening the lock nut (3), adjusting the nut (4) so that the lever is vertical, then tightening the lock nut (3) again.

If the brake does not apply despite the adjustment described above, the brake disc can be adjusted with the screw (5) at the lower part of the brake lever.

Rider 112 C/115 C/120 C

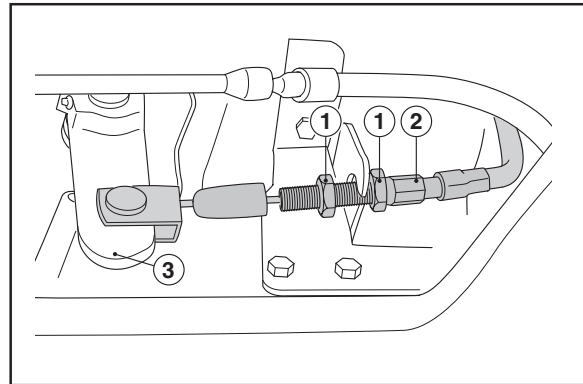

The brake is correctly adjusted when there is no play in the cable.

- 1 Loosen the lock nuts (1).
- 2 Stretch the cable with the adjustment screw (2)
- 3 Tighten the lock nuts (1) after adjustment. When the brake cable is adjusted, make sure there is no play.



WARNING!
A poorly adjusted brake can result in reduced braking ability.

Checking and adjusting the gear control

Rider 111 B5/112 C5

Check the gear control adjustment by putting the gear lever in the "N" position. If the machine moves easily, the lever is properly adjusted.

Otherwise the controls should be adjusted as follows:

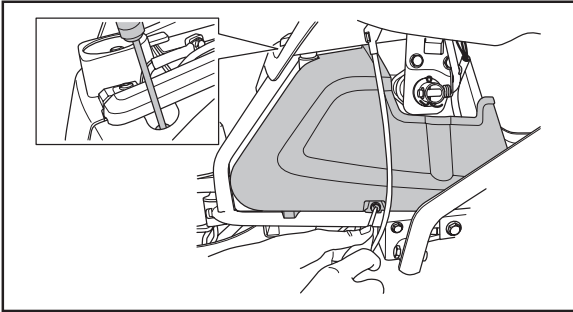

- 1 The cutting unit should be lowered. Remove the cover on the right hand side of the front carriage.

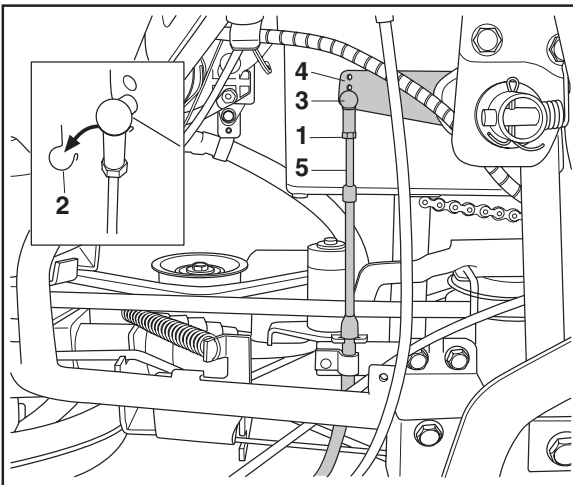

- 2 Loosen the lock nut (1) on the ball joint.
- 3 Remove the locking spring (2) so that the ball socket (3) can be removed from the ball on the lever (4).
- 4 Adjust the socket (3) position on the draw bar (5) until the socket can easily be placed on the ball.
- 5 Lock the adjustment with the locking nut (1) and refit the locking spring (2).

Checking and adjusting the clutch

Rider 111 B5

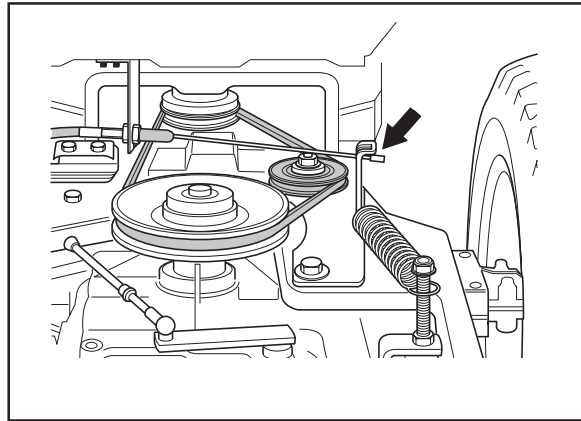

Rider 112/ /112 C5/ 115 C/ 120 C

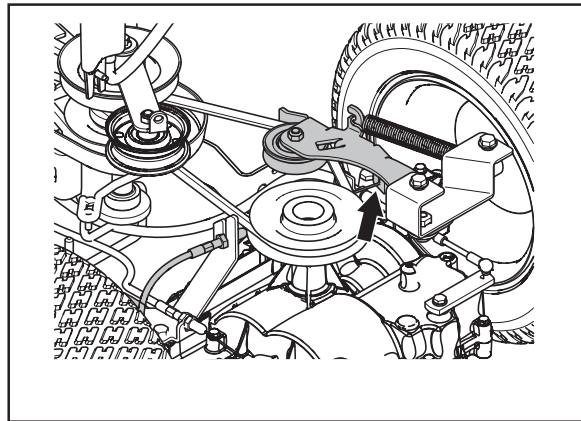

- 1 The clutch is properly adjusted when the idler's outward motion is stopped by the belt and not by the cable.

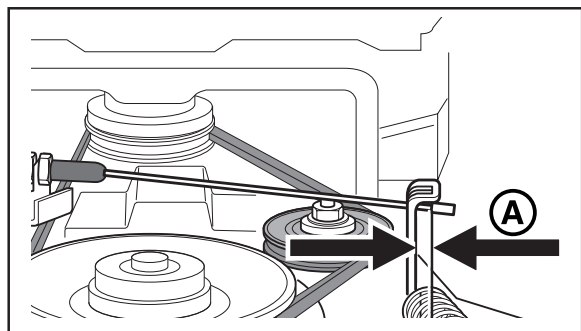

- 2 There should be about 8–10 mm/5/16"-3/8" of play (A) between the cable nipple and the lever.

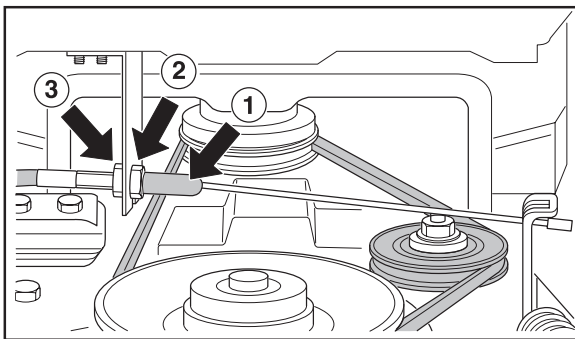

3 Adjust the clutch cable as follows:

- Pull out the rubber sleeve (1). Loosen the nut (2) and adjust the wire using the adjuster screw (3).
- Tighten the lock nut (2) after adjustment.

Checking and adjusting the accelerator

Rider 111 B/ 112 C/115 C/120 C

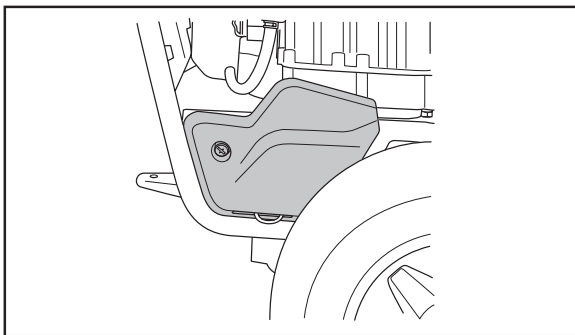

- 1 Remove the cover on the right side of the rear carriage.

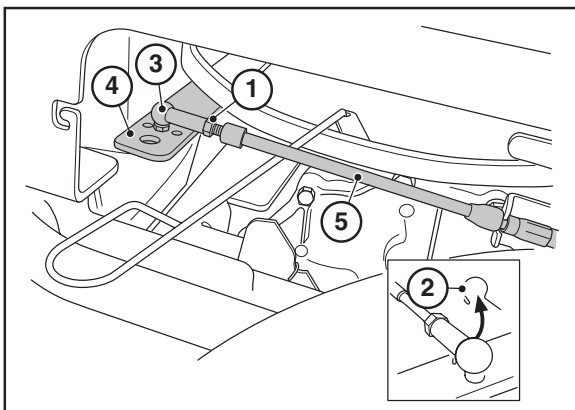

- 2 Loosen the lock nut (1) on the ball joint.
- 3 Remove the locking spring (2) so that the ball socket (3) can be removed from the ball on the lever arm (4).
- 4 Press the forward accelerator pedal down completely and move the lever arm (4) forwards as far as possible.
- 5 Adjust the socket (3) position on the connecting rod (5) so that it fits exactly over the ball on the

lever arm. Fit the socket on the ball.

- 6 Lock the adjustment with the lock nut (1) and put the locking spring (2) in place.

Changing articulated steering bearing

Rider 111 B5

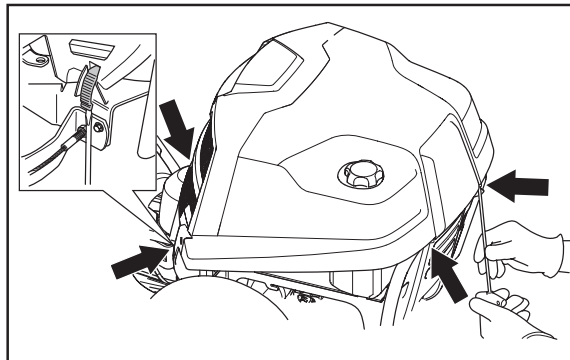

Rider 112/ /112 C5/ 115 C/ 120 C

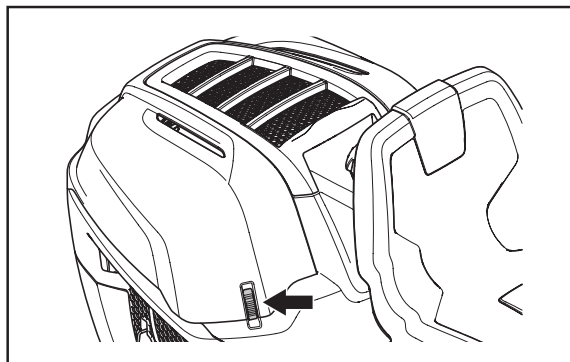

- 1 Remove the engine cover by loosening two snap-in locks at the front and two hinges at the back edge of the engine cover (Only 111B, 111B5).

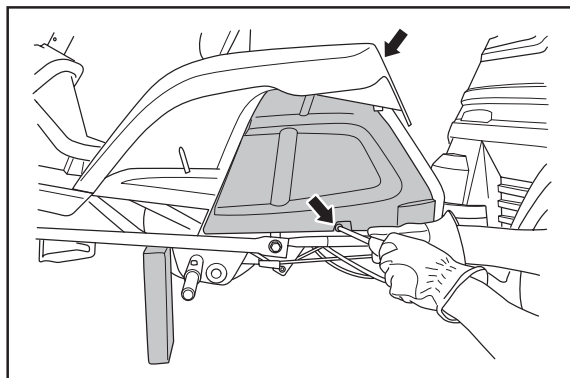

- 2 Remove the side cover on the left hand side of the front carriage. One screw at the side and one at the top, under the seat.

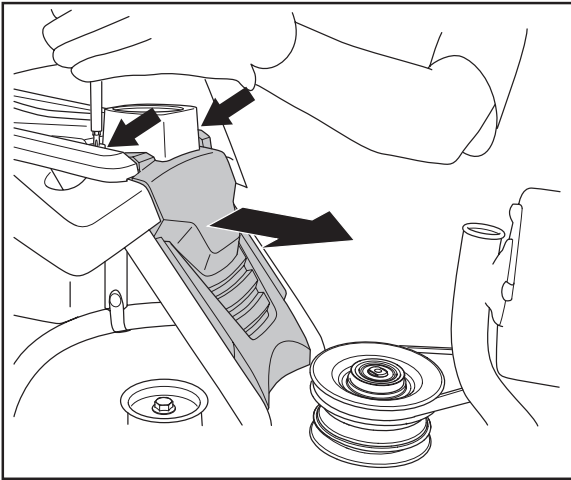

3 Remove the rear cover of the front carriage.

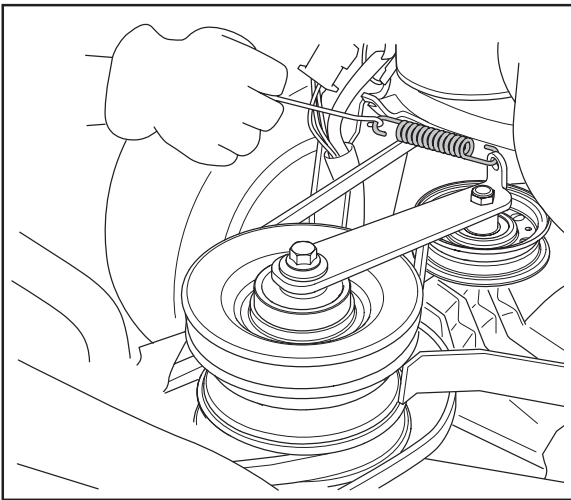

4 Loosen the spring for belt 1 (engine belt) using a spring hook.

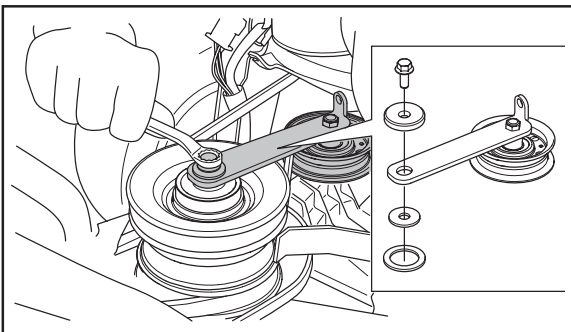

5 Remove the belt tensioner.

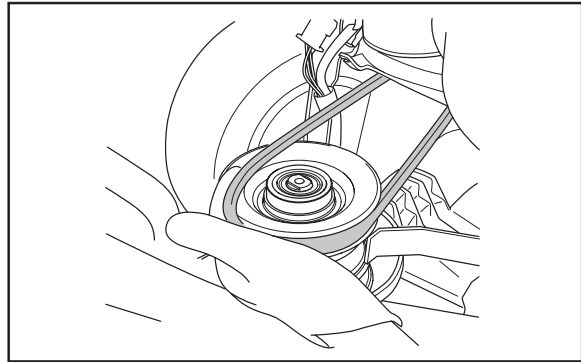

6 Pull belt 1 off the belt pulley.

Rider 111 B5/112 C5:

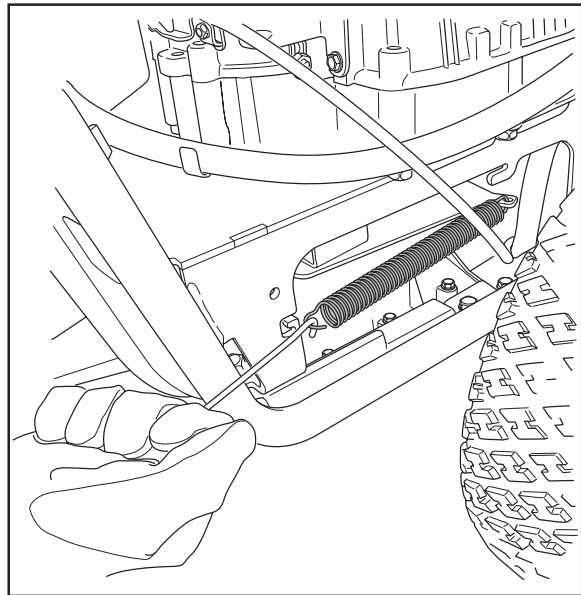

7 Loosen the spring that is tensioning belt 2 (transmission belt) using a spring hook.

Rider 111 B/112 C/115 C/120 C:

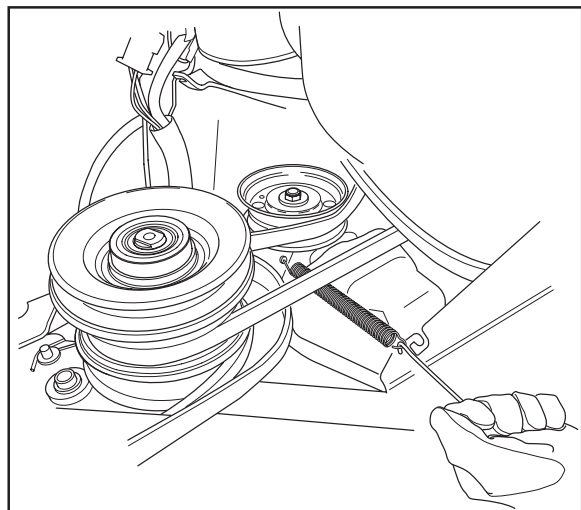

7 Loosen the spring that is tensioning belt 2 (transmission belt) using a spring hook.

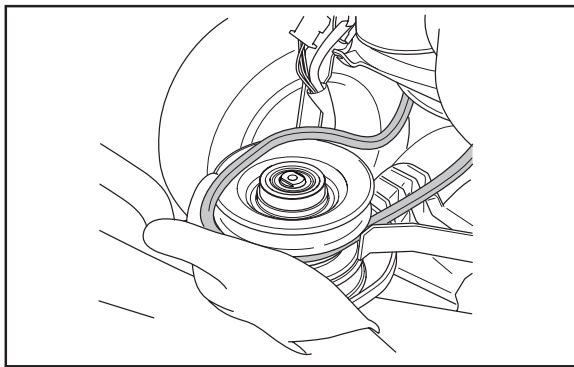
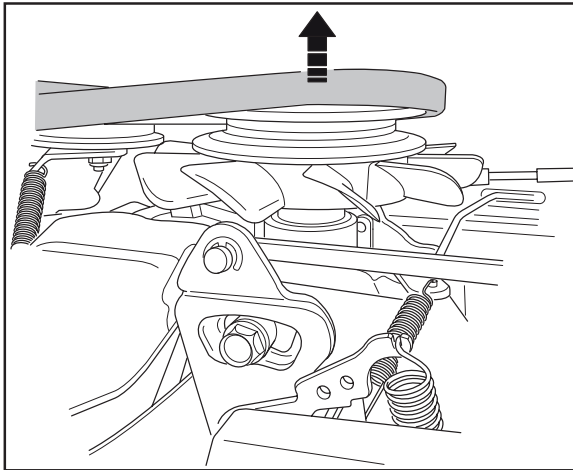

8 Pull off belt 2 from the transmission, first from the rear belt pulley and then from the front.

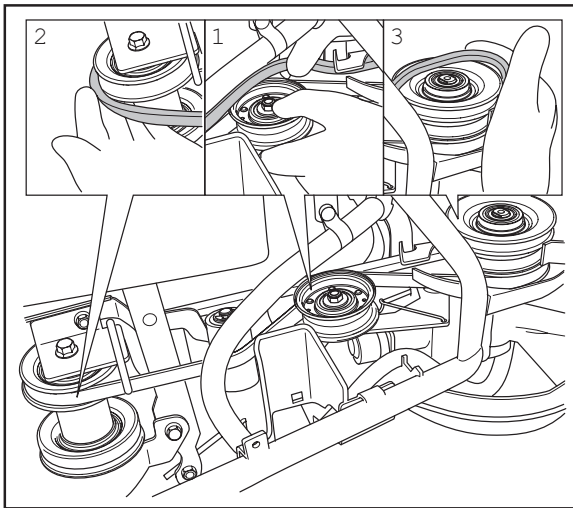

9 Loosen belt 3 (cutting unit drive) from the tension roller. Then pull it off from the center belt pulley, then from the belt pulley of the articulated steering.

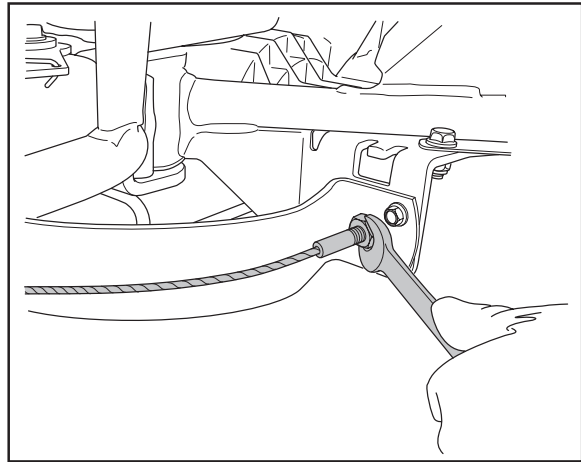

10 Remove the rear attachments of both steering cables.

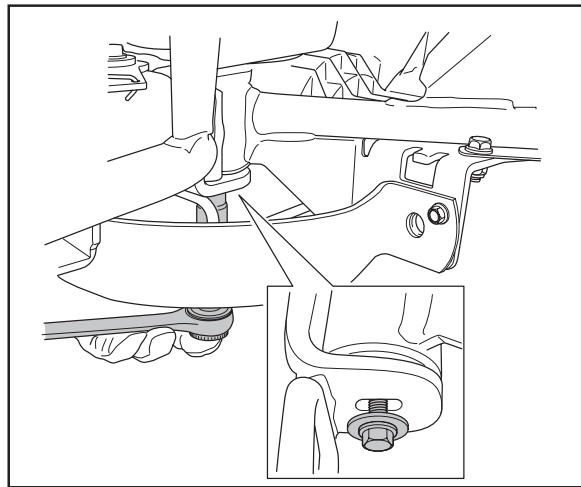

11 Loosen the articulated shaft's screw from below.

Rider 111 B5/112 C5

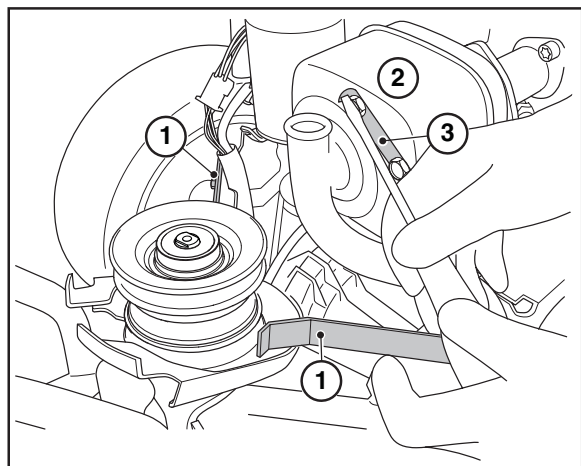

12 On Rider 111 B5 and 112 C5 a belt guide (1) must be removed. On 111 B5 the muffler (2) must also be removed.

Fold the plate (3) out of the way.

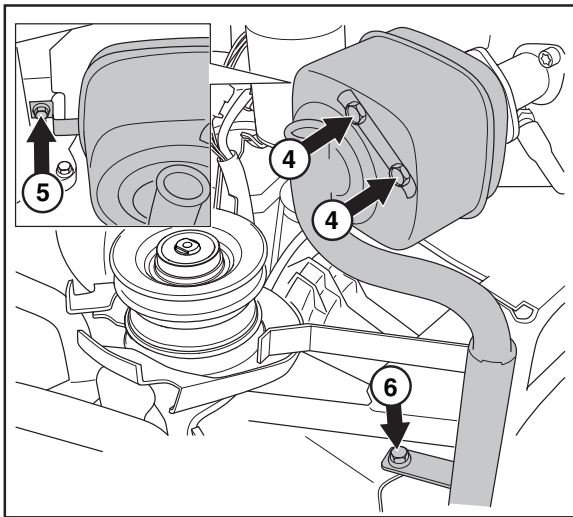

13 Loosen the two screws (4) using a half-inch wrench. Loosen the screw (5) behind the muffler and the screw (6) holding the exhaust pipe. The belt guide can now be removed.

IMPORTANT INFORMATION

When assembling, the gasket between the muffler and the exhaust pipe must be replaced.

Rider 111 B5

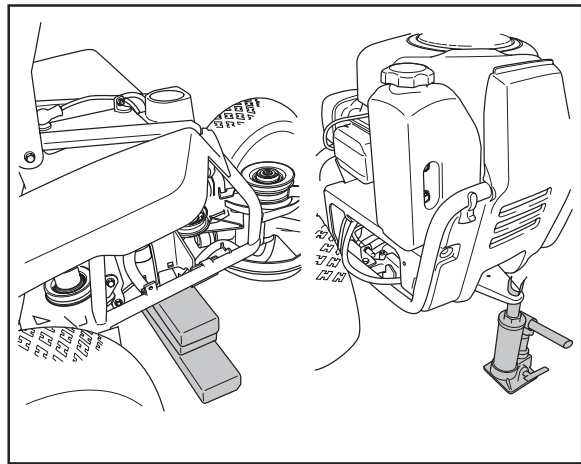
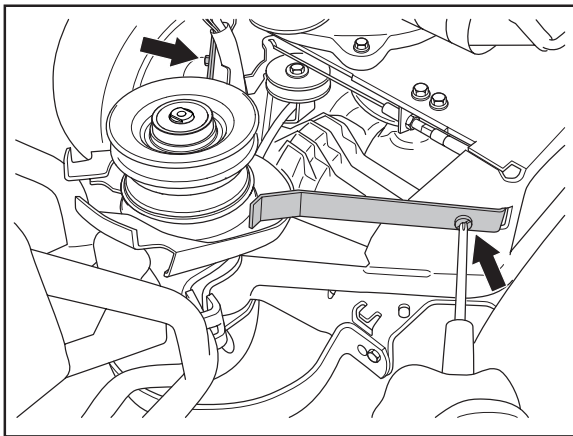

14 Jack up the front carriage in front of the cable pulley without squeezing any cables. Jack up the rear carriage in the rear edge.

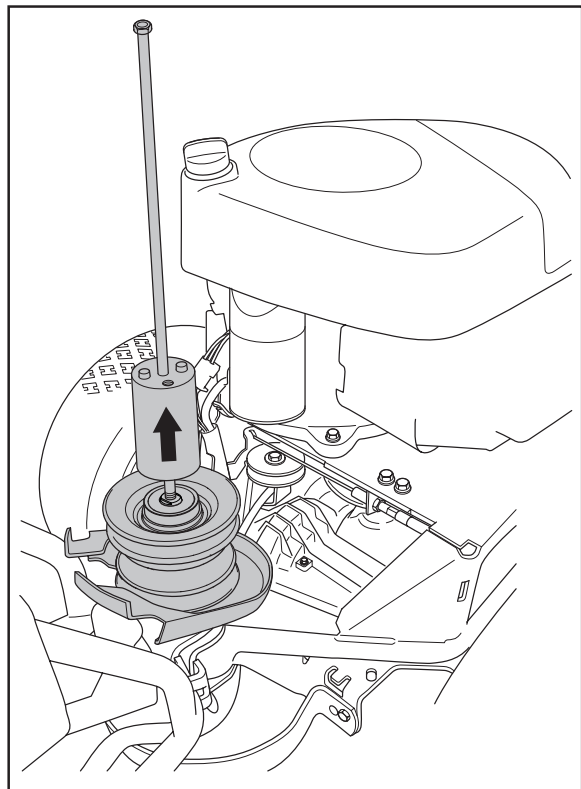

15 Use a slide hammer size M8 to loosen the articulated shaft and the belt pulleys.

16 Separate the front and rear carriages.

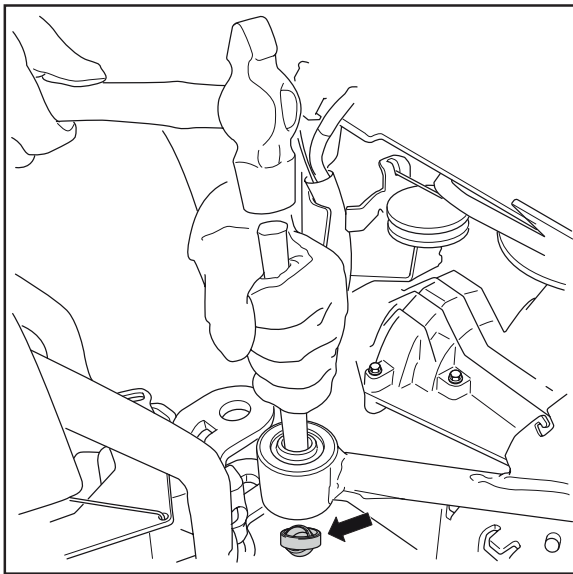

17 Tap out the bearings and the sleeve with a mandrel. The lower bearing is tapped out from above. The upper bearing is tapped out from below.

18 Press new bearings in by using a bearing assembly kit.

19 Assemble the articulated steering in the reverse order as set out for removal. If the pendulum shaft needs replacement, refer to "Removing the Pendulum Shaft".

After assembly, the cable tensioning must be checked (see "Checking and Adjusting the Steering Cables"). Check that the controls and cables are properly adjusted.

Removing the pivoting rear axle

- 1 Follow step 1 to 15 in "Replacing the Articulated Steering Bearings".
- 2 Remove the front wheels to obtain better access.
- 3 Remove all the cables laid out between the front and the rear carriage, in their rear attachments. Make a note of how the cables are laid out.

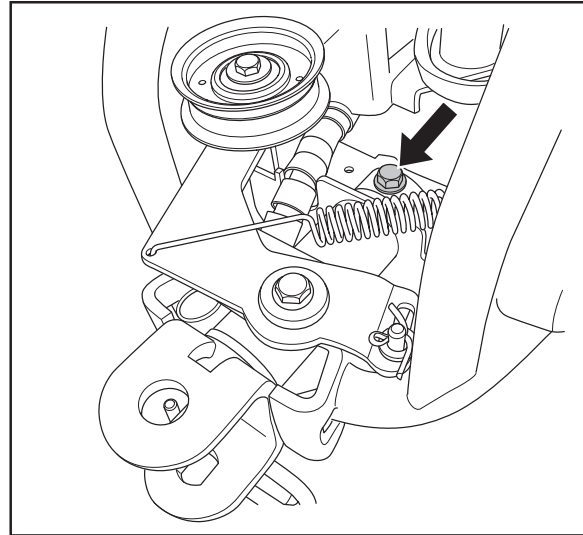

- 4 Remove the screw holding the pendulum shaft package.

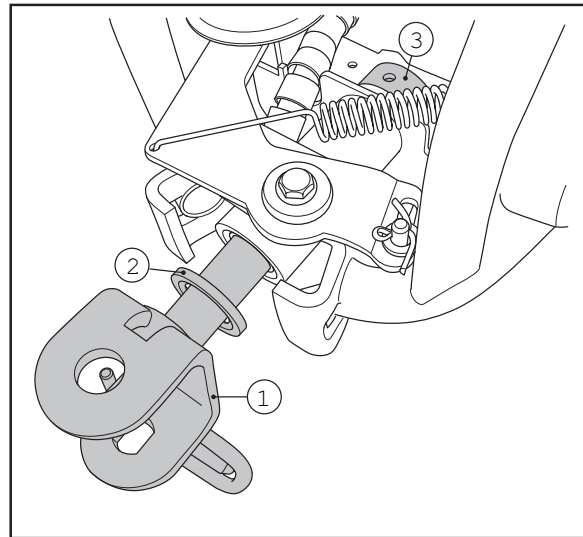

- 5 Pull the pendulum shaft (1) with the washer (2) out. The ring (3) will come off.

Replacing the pendulum shaft bushings

Once the swing axle has been removed, the bushings in the rear frame must be changed.

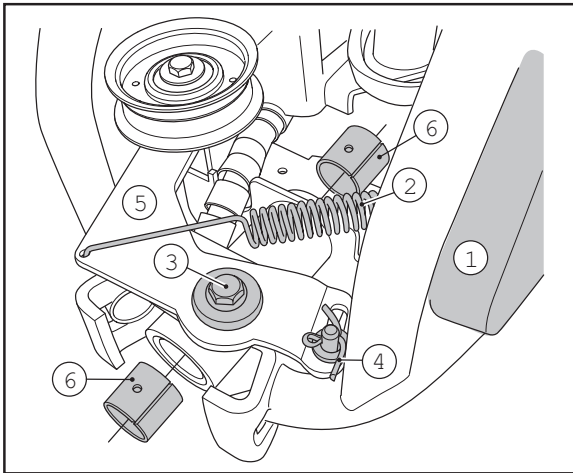

Remove the cover (1) on the right hand side. Loosen the spring (2) with a spring hook. Loosen the screw (3) and the cotter pin (4), then remove the belt tensioner (5). Remove the bushings (6), one from each direction.

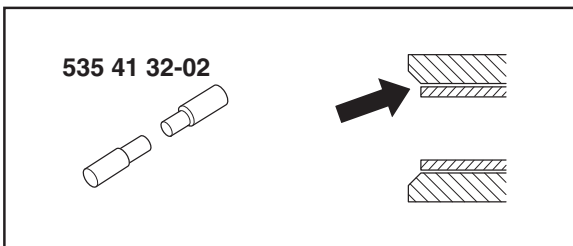

The bushings must be initially lubricated with a lithium-based grease. New bushings are fitted with the mandrel, refer to "Special tools".

It is important that the outer bushing's outer edge is on the same level as the beveled edge of the hole. When the bushings are positioned, the belt tensioner is fitted with the spring again.

Replacing the bearings in the articulation unit belt pulleys

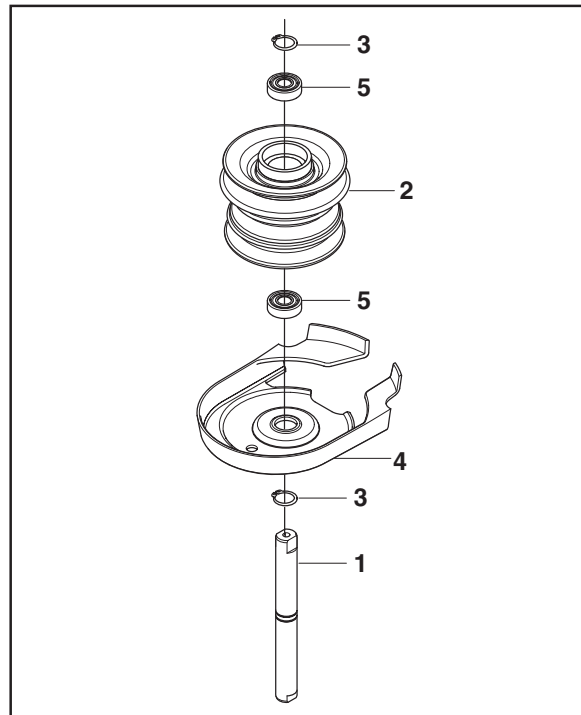

- 1 Remove the articulated shaft with belt pulleys, refer to "Replacing the Articulated Steering Bearings", step 1 to 14.
- 2 Remove the lock rings (3) holding the belt pulleys (2) and the plastic cover (4) in the upper and lower sections.
- 3 Press the shaft (1) out from the belt pulleys (2).
- 4 Tap out the bearings (5) in the upper and lower sections.
- 5 Press new bearings in using a bearing assembly kit. Assemble in the reverse order.

Assembling the pivoting rear axle

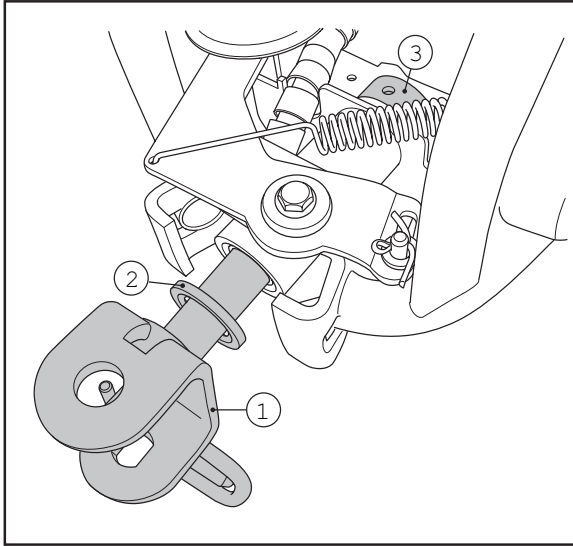

- 1 Slide the washer (2) on the pendulum shaft with the beveled edge against the fork (1) of the pendulum shaft.
- 2 Grease the shaft and assemble it in the front frame.
- 3 Slide the ring (3) on from behind and fasten the screw.

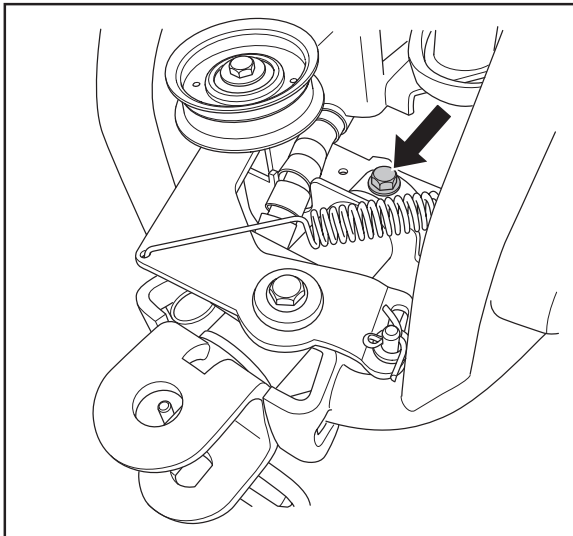

- 4 Roll the rear carriage forward and fit it into the fork of the pendulum shaft.

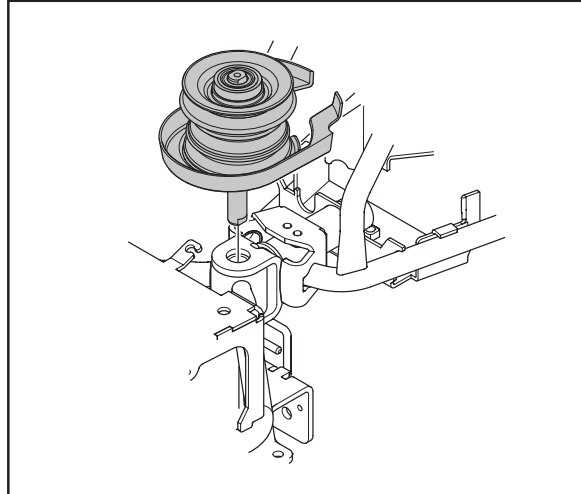

- 5 Fit the articulated shaft with the short key grip and plastic cover face down. Ensure the double D shaft is inserted into the double D hole on the fork.
- 6 Fasten the cables in their respective positions between the front and the rear carriage.
- 7 Fit the wheels.
- 8 Assemble according to "Replacing the Articulated Steering Bearings", reverse order.

Make sure that the cables and controls are properly adjusted (see Checking and Adjusting the respective cables).

Replacing the hydrostatic cable

Rider 111 B/112 C/115 C/120 C

Removing the hydrostatic cable

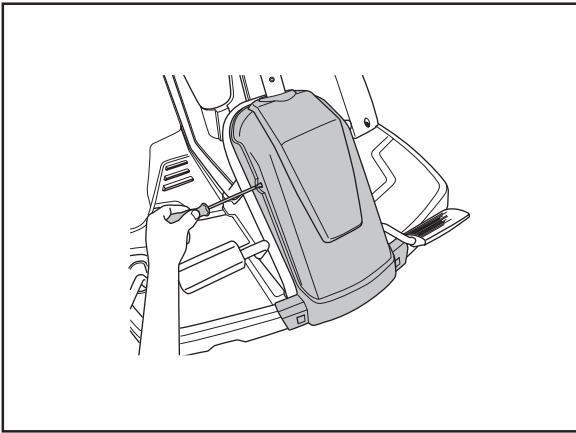
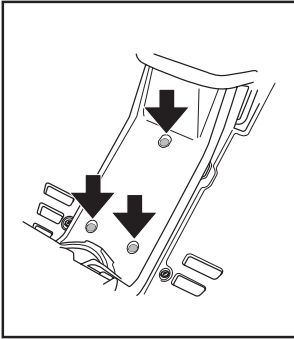

1 Remove the frame cover and the front cover.

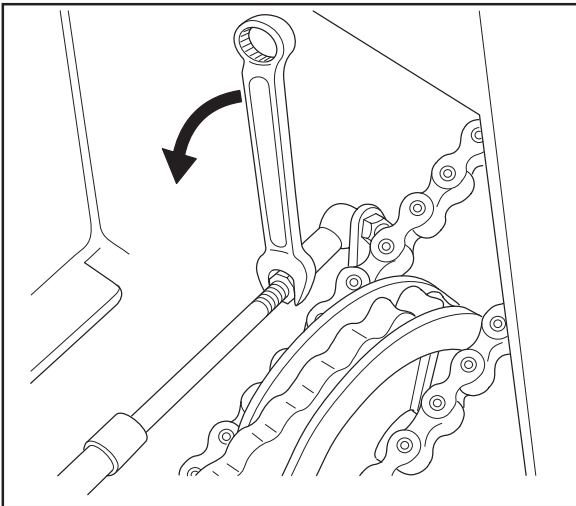

2 Loosen the hydrostatic transmission cable locking nut 1/4 turn.

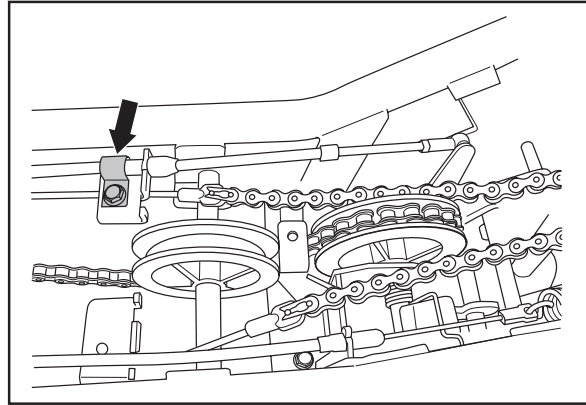

3 Remove the front hydrostatic cable clamp that is fastened inside the center console.

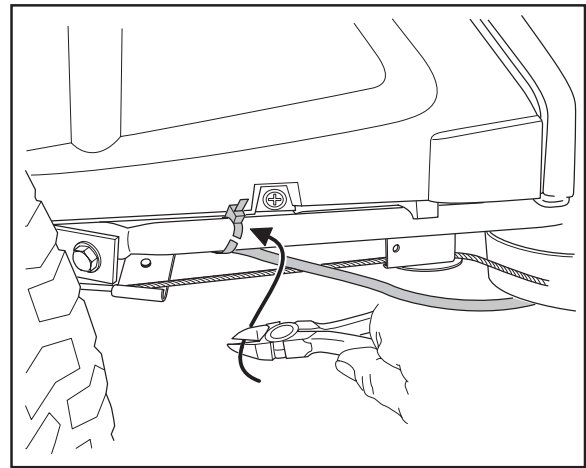

4 Cut off the plastic tie around the cable at the frame situated in front of the left front wheel.

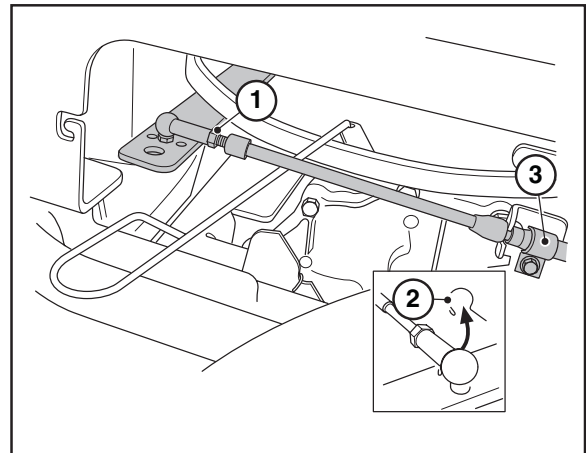

5 Loosen the M5 nut (1) and remove the locking spring (2) by the hydrostatic transmission's rear link joint. Loosen the clamp (3) holding the cable cover.

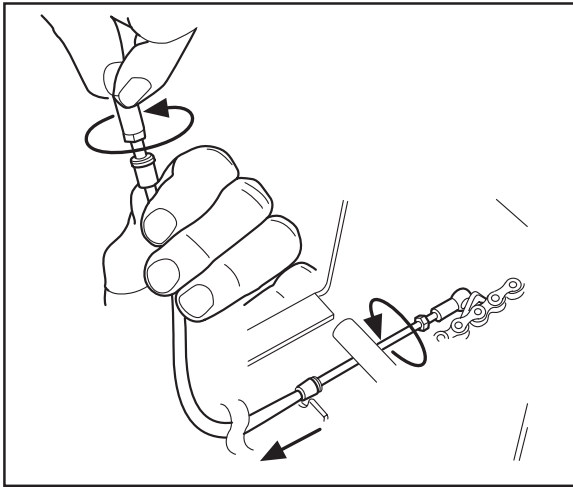

- 6 Lift the link joint off and remove the hydrostatic cable. Loosen the rear link joint from the cable. Turn the cable so that it comes loose from the front link joint.

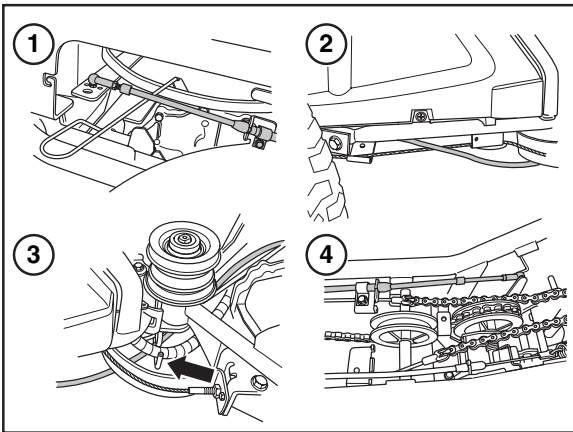

- 7 Remove the whole hydrostatic cable. Make a note of how the cable is laid out, so that the new cable can be correctly positioned.

Fitting the hydrostatic cable

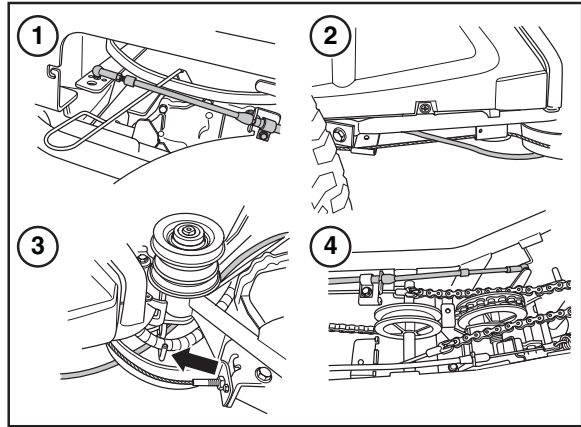

- 1 Feed the new cable through the Rider so it runs the same route as the old one.

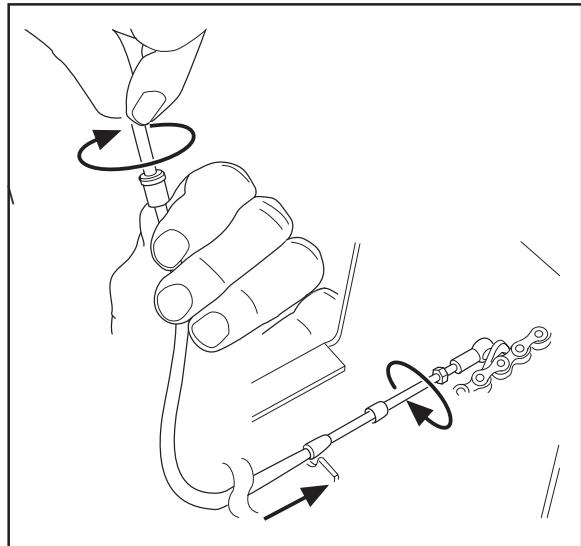

- 2 Screw the new hydrostatic cable in as far as possible on the front link joint and tension the locking nut.

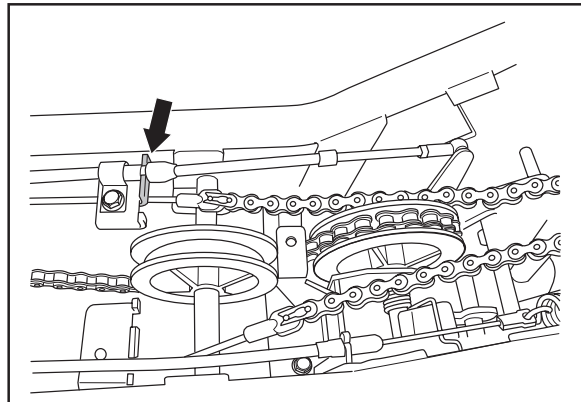

- 3 Press the cable sheath into the front attachment in the center console.

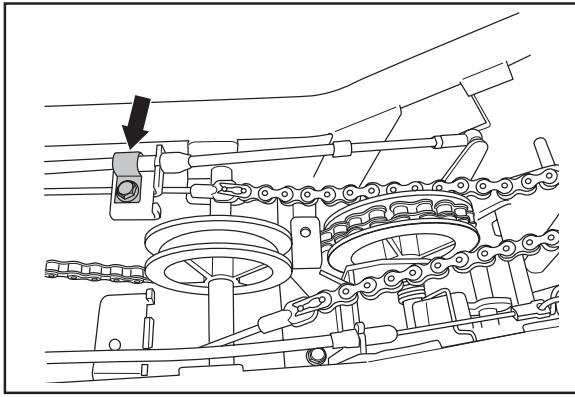

4 Tighten the hydrostatic transmission cable clamp.

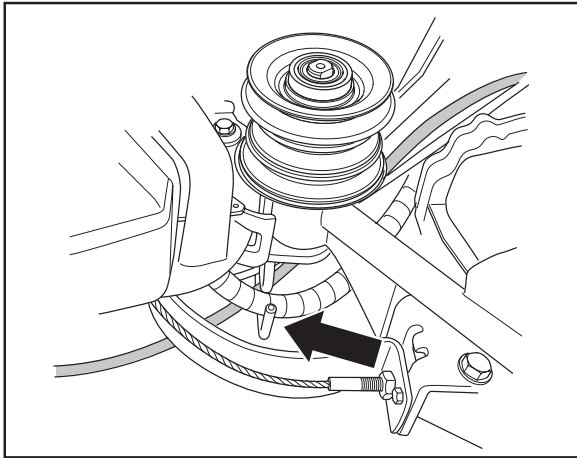

5 Place the hydrostatic cable at the lowest position in the fork below the pendulum shaft.

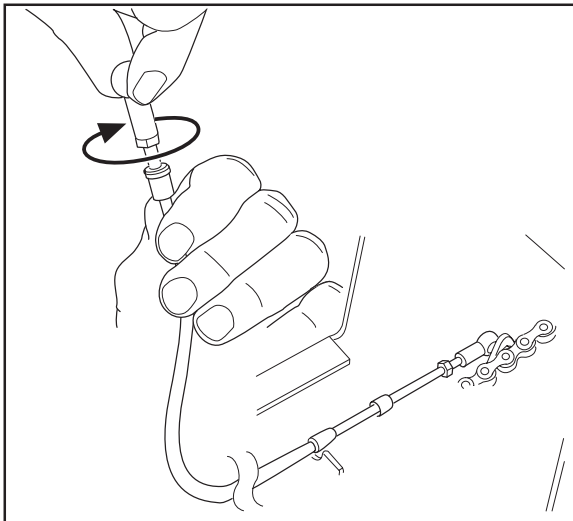

6 Attach the link joint to the lower part of the hydrostatic transmission cable.

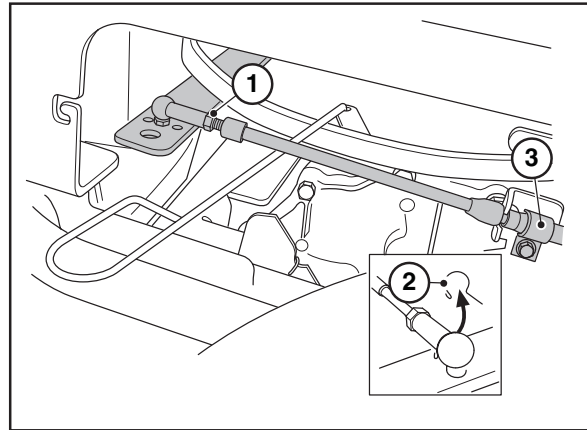

7 Place the hydrostatic transmission cable in place and screw the casing on with the rear bracket (3).

8 Adjust the hydrostatic transmission cable as shown, see Checking and Adjusting the Accelerator.

Connect the rear link joint and fit the locking spring (2).

Tighten the rear link joint locking nut (1).

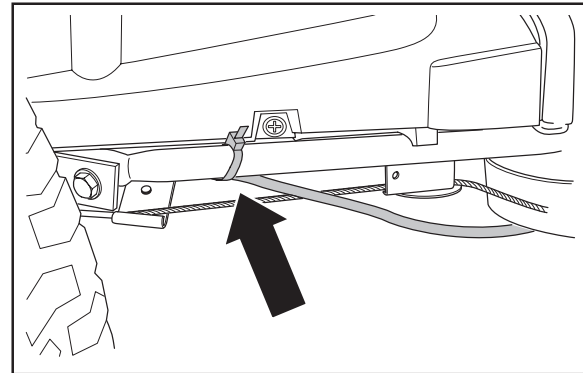

9 Secure the hydrostatic cable with plastic ties in the frame behind the left front wheel.

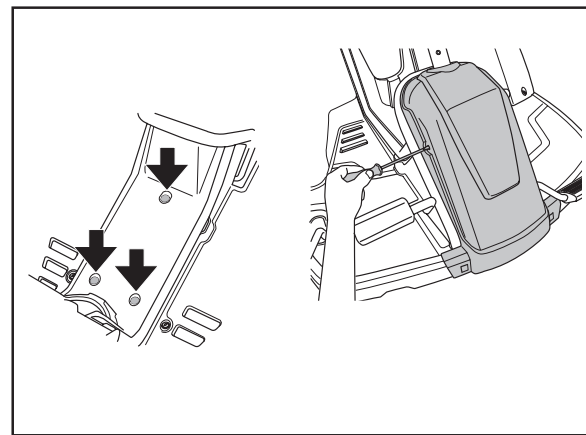

10 Fasten the frame cover and the front cover.

Replacing brake cable

Removing the brake cable

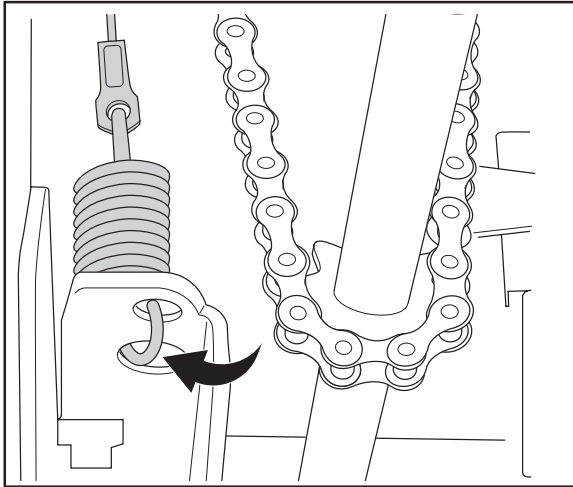

- 1 Unhook the spring in the front part of the brake cable.

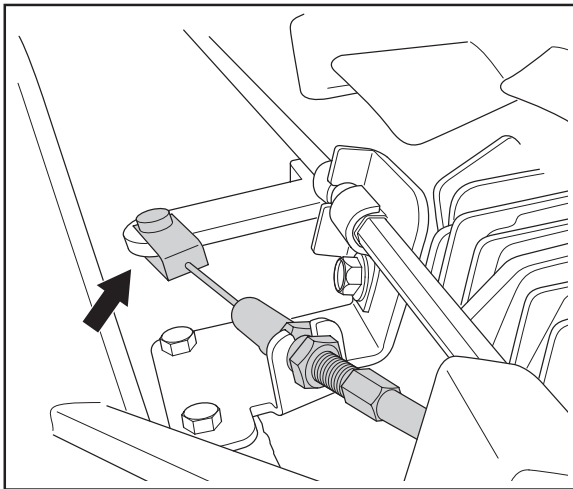

- 2 Loosen the rear part and remove the brake cable from the Rider.

Fitting the brake cable

- 1 Pull through the new brake cable on the Rider.

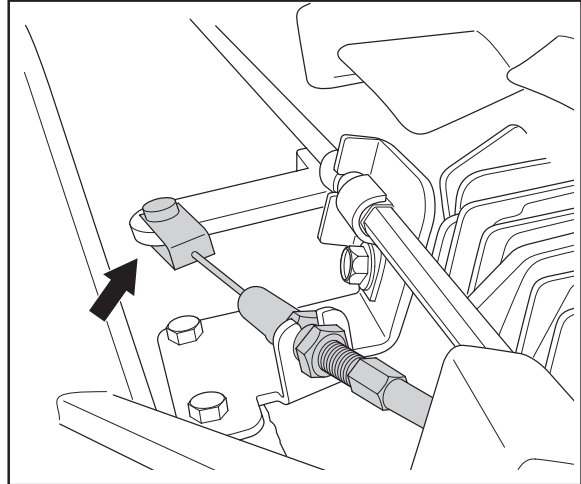

- 2 Fit the rear of the cable.

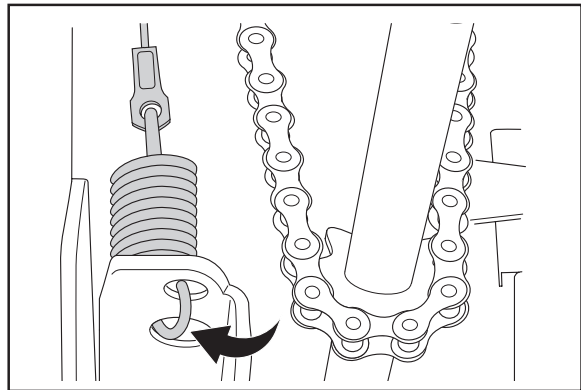

- 3 Fit the front part of the cable by hooking on the spring.

Replacing belt 4, as far as the cutting unit

Starting position for removing belts:

- No unit is attached to the machine.
- The front part of the belt is loose.
- The lifting lever is lowered.

- 1 Jack up the front carriage and remove the left front wheel.

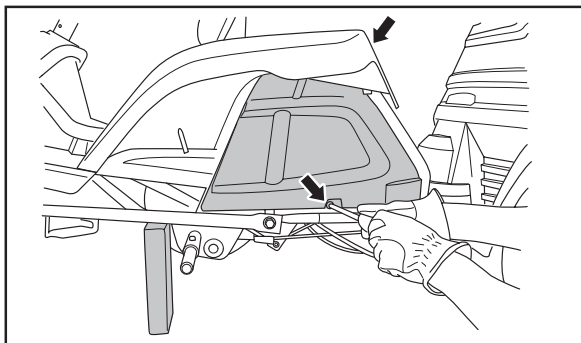

- 2 Remove the side cover. One screw at the side and one at the top, under the seat.

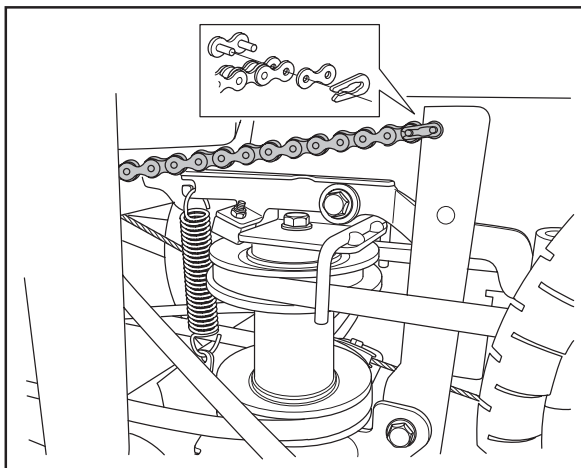

- 3 Remove the lifting chain from the lever arm of the cutting unit.

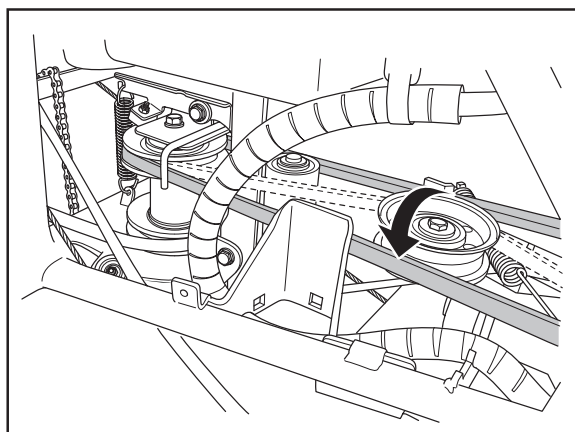

- 4 Lift off belt 3 (cutting unit drive) from the belt tensioner.

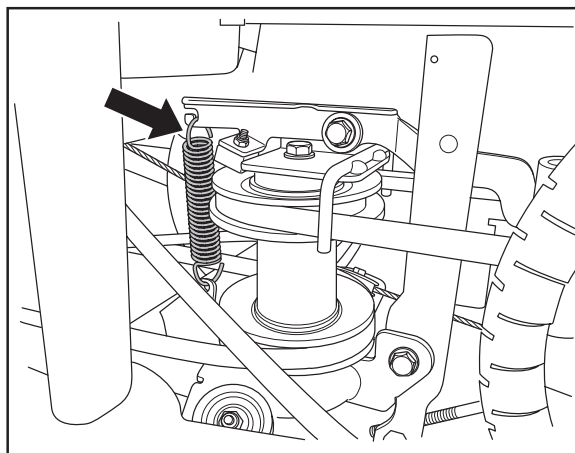

- 5 If mouted, unscrew the blade brake package. Unhook the spring using a spring hook. Note that it should be placed with the loop to the right during the assembly, to prevent the lifting chain from getting stuck.

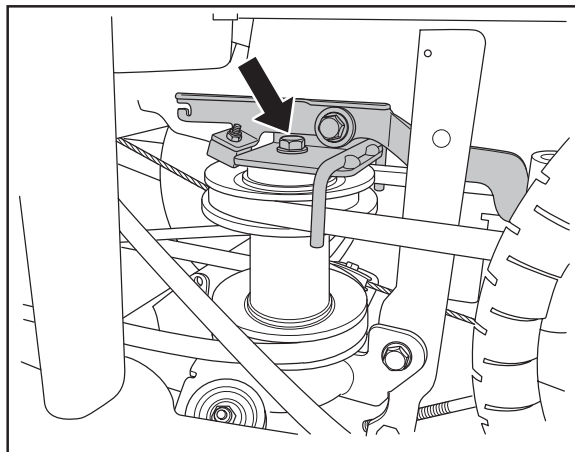

- 6 Unscrew the brake.

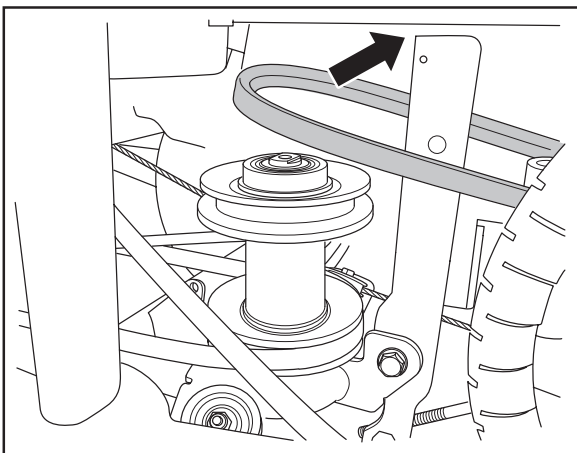

7 Pull belt 3 off the unit belt pulley.

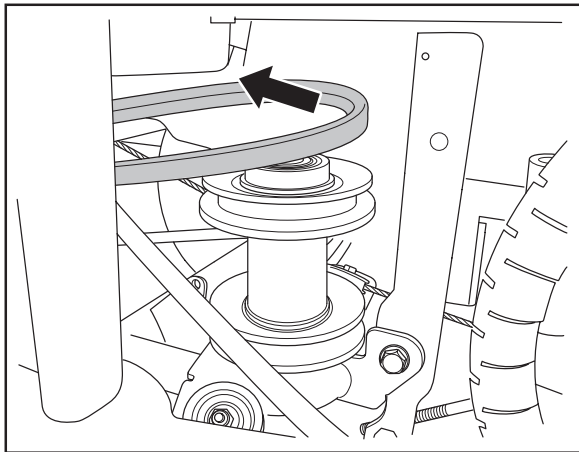

8 Lift off belt 4 over the unit belt pulley and forwards.

Fit the belt in the reverse order.

Replacing belt 3, cutting unit drive

Follow the instructions for "Replacing belt 4, as far as the cutting unit" up until step 7. Then proceed according to the following instructions:

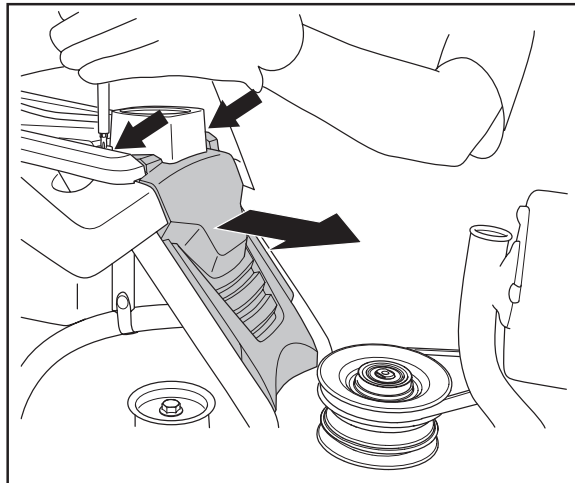

1 Remove the rear cover of the front frame.

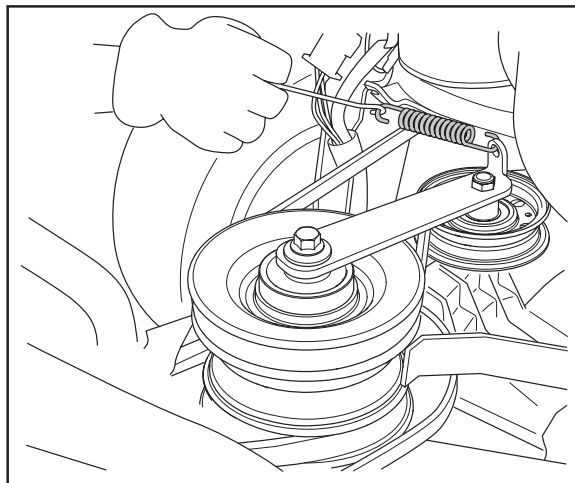

2 Remove the spring for the belt tensioner for belt 1 (engine belt).

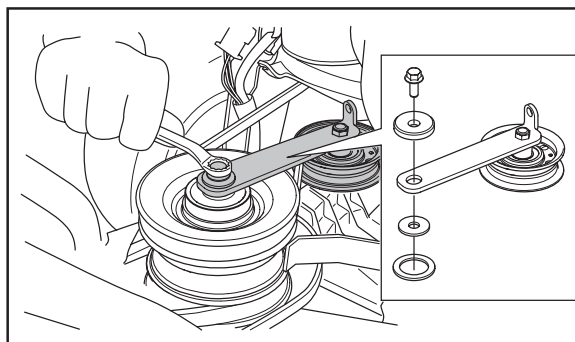

3 Remove the belt tensioner for belt 1.

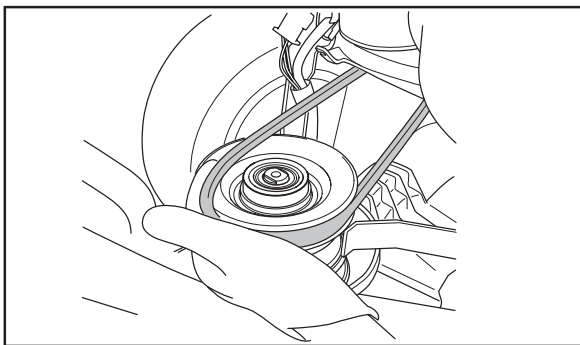

4 Lift off belt 1.

5 Remove the spring for the belt tensioner for belt 2 (transmission belt).

Rider 111 B5:

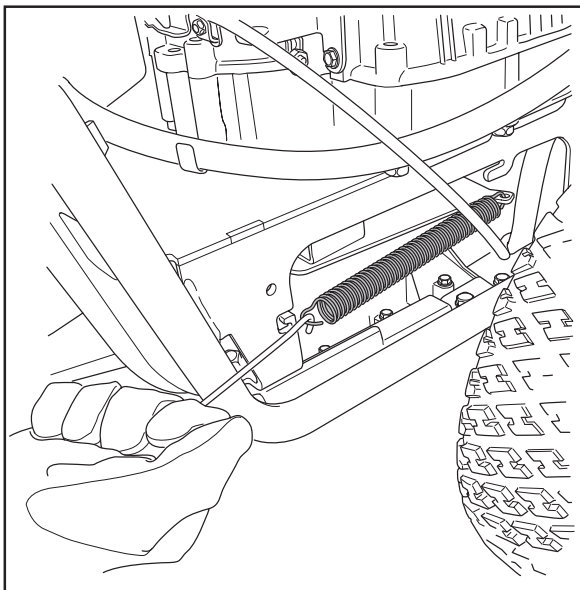

Rider 111 B/112 /115 C/120 C:

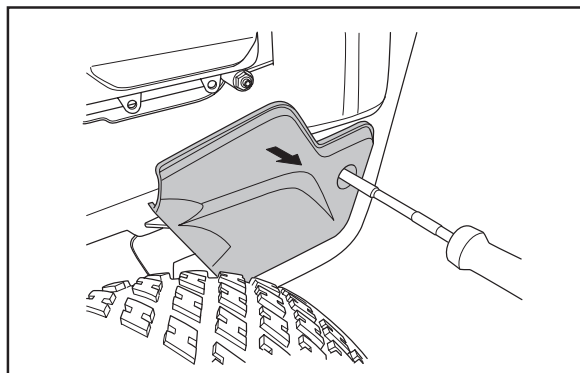
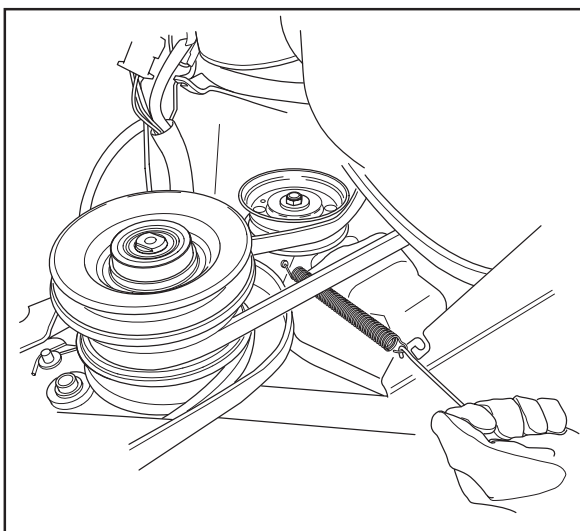

6 Remove the cover on the left hand side of the rear carriage.

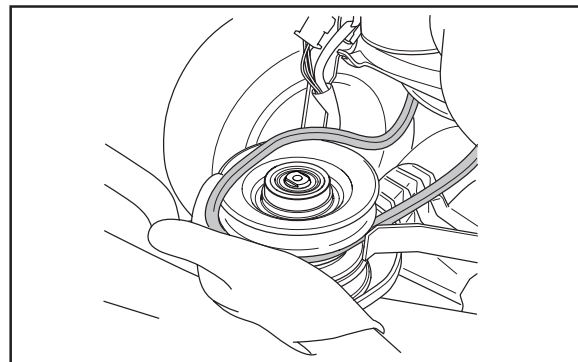
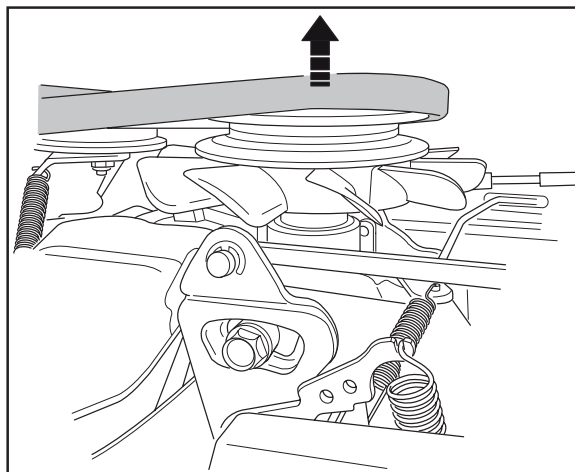

7 Pull off belt 2 from the transmission, first from the rear belt pulley and then from the front.

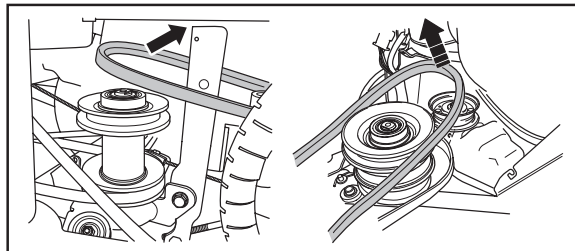

8 Pull off belt 3 at the front, lift it over the lever arm of the cutting unit, then lift it off at the rear.
Fit the belt in the reverse order.

Removing the cutting unit

The cutting unit can be removed in order to facilitate cleaning and servicing.

To remove the cutting unit proceed as follows:

- 1 Put the machine in a level position.

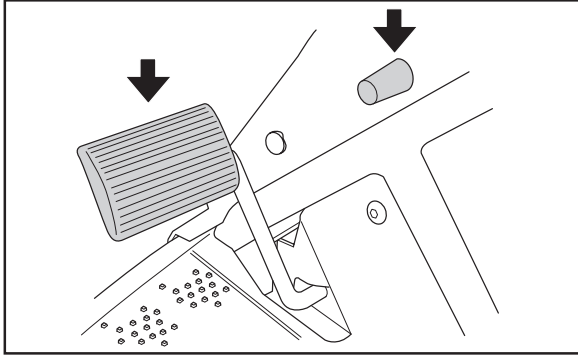

- 2 Apply and secure the parking brake.

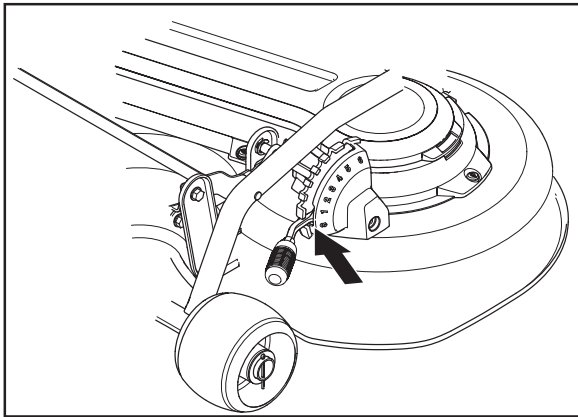

- 3 Check that the lever for setting the cutting height is in the S position.

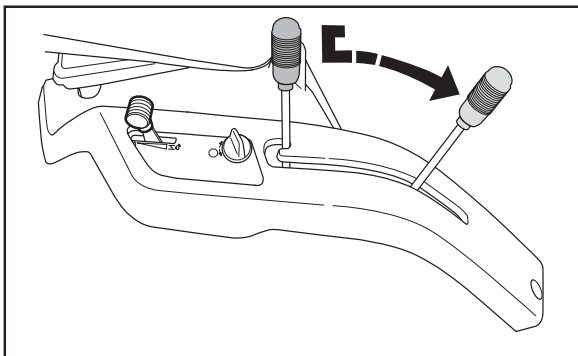

- 4 Move the lifting lever to cutting position.

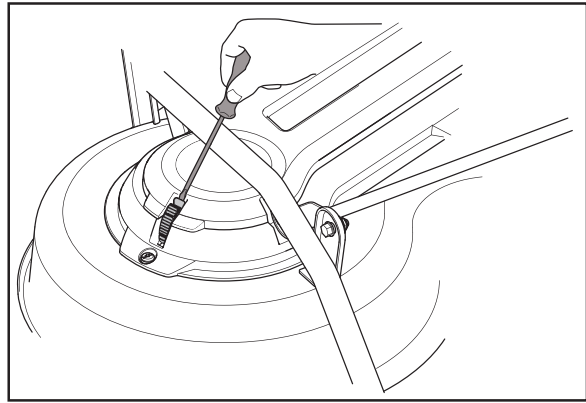

- 5 Loosen the snap-in lock and lift off front cover.

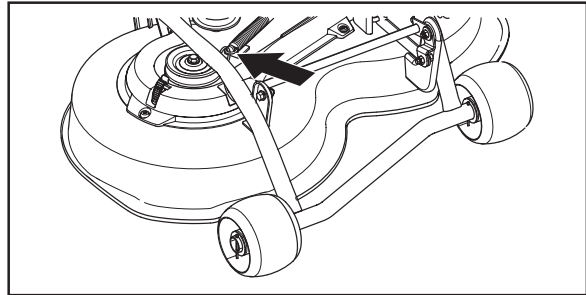

- 6 Unhook the spring.
- 7 Lift off the drive belt.

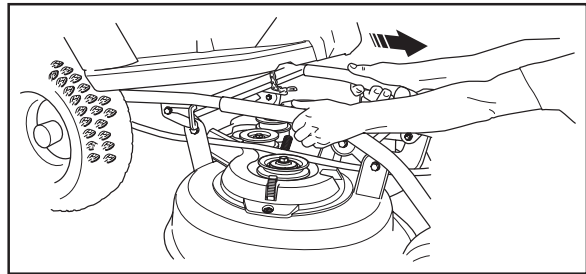

- 8 Grab the upper pipe construction of the unit and pull it out until it stops.
- 9 Make sure the equipment lock is in upright position.
- 10 Loosen the stay from the cutting deck by removing the pin.
- 11 Grab the upper pipe construction of the unit and pull it out.

Service position for cutting unit

Follow the instructions for "Removing the cutting unit" above. Lift off the unit and lean it against the machine or a wall.

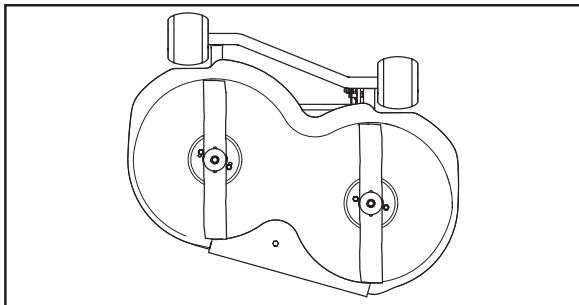

Attaching the cutting unit

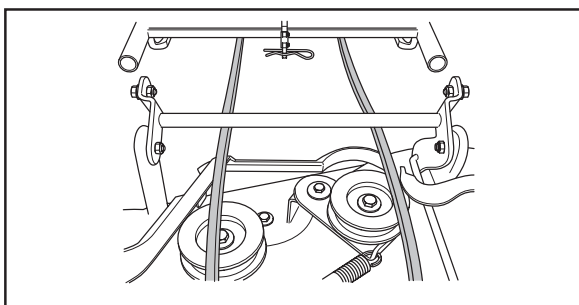

1 Place the belt under the stay of the cutting unit.

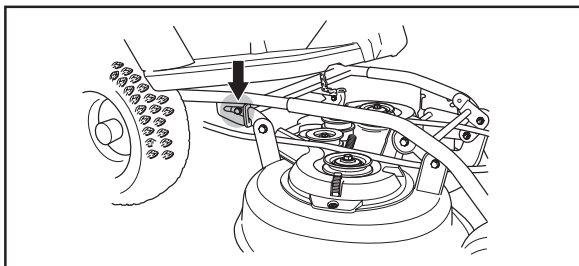

2 Fit the cutting unit's pipe together with the unit frame's pipe. Push the cutting unit in and make sure the guide bolts fit into the grooves on the unit frame, one on each side.

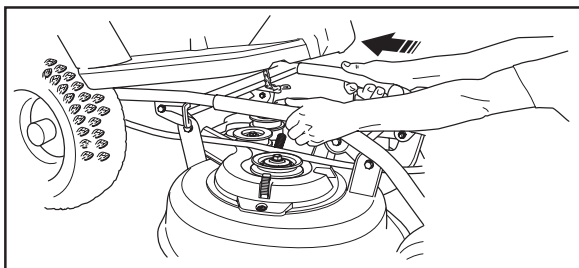

3 Grab the pipes and push the unit in.

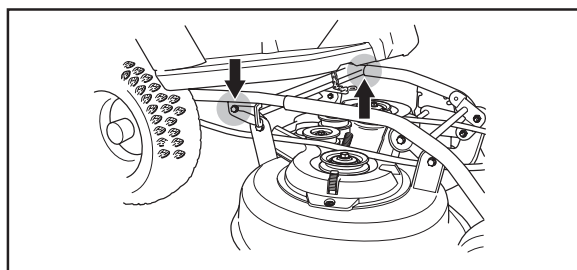

4 Push the unit until you feel the pipes touch bottom.

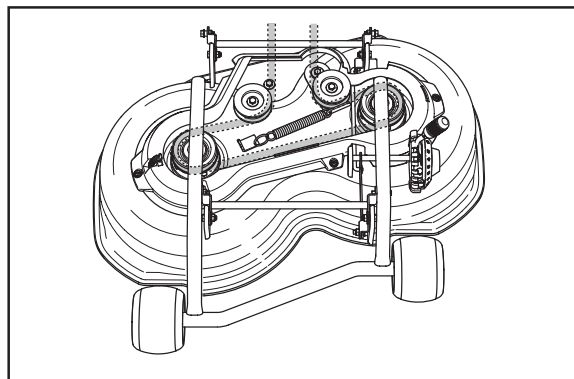

5 Fit the belt according to the picture.

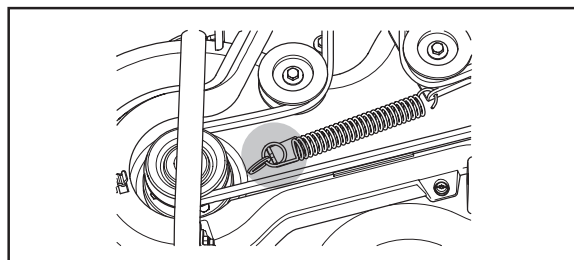

6 Tighten the belt with the belt tensioner.

7 Fit the front cover.

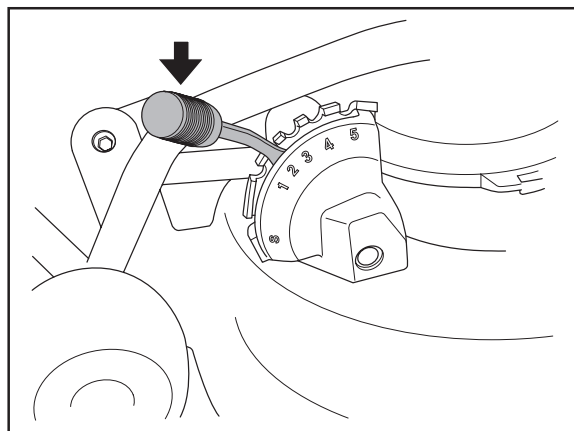

8 Move the cutting unit height control from the S position to any of the other positions.

Removal of blades and blade housing



WARNING!
Use gloves and protective goggles when working on the cutting unit.

The cutting unit should be removed from the machine, see "Removing the cutting unit".

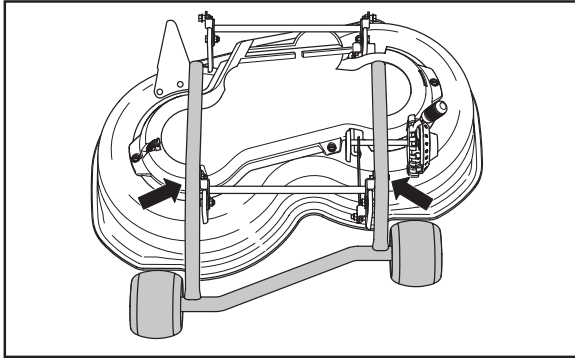

1 Remove the front equipment frame.

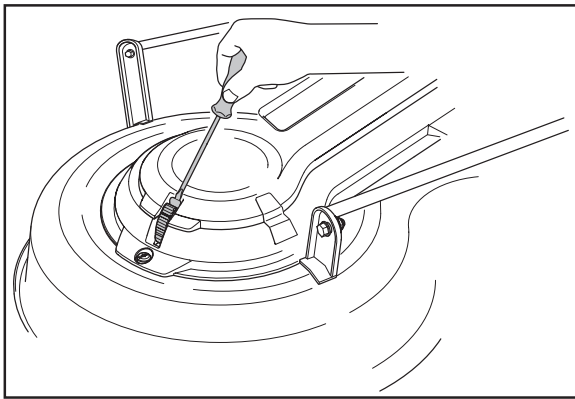

2 Remove the upper cover of the cutting unit by opening the snap-in lock.

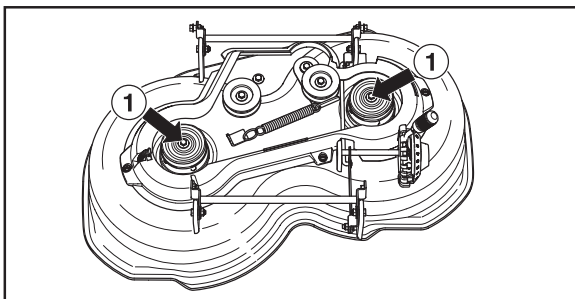

3 Remove the screw holding the deck belt pulley (1).

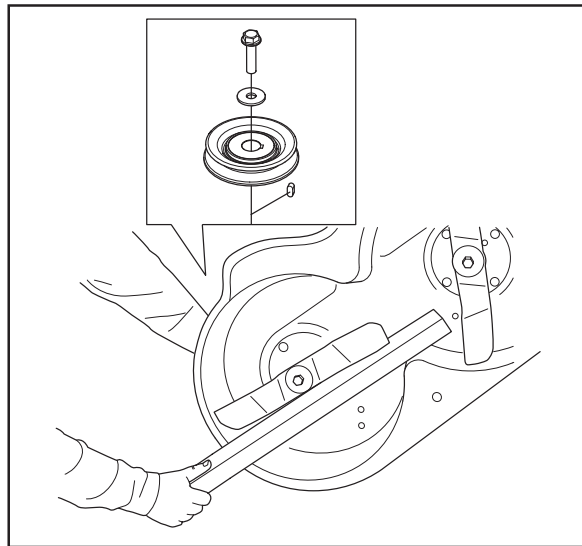

4 Secure the blade with a wooden block or hold the belt pulley with an oil filter puller for example. Do not misplace the key that is between the belt pulley and the shaft. Remove the deck belt pulley. You might need a wrench to do so.

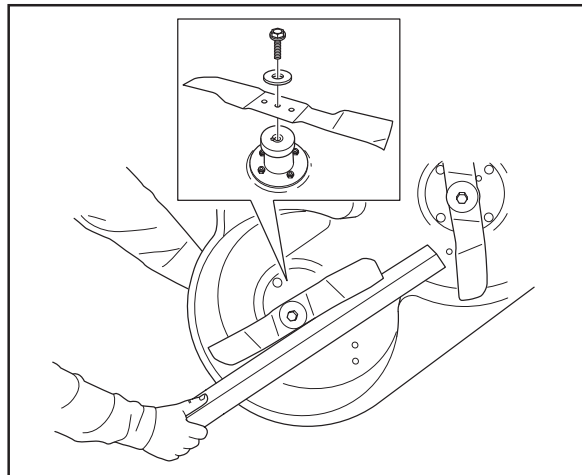

5 Lock the blade with a wooden block. Loosen the blade bolt and remove the blade bolt, washer and blade.

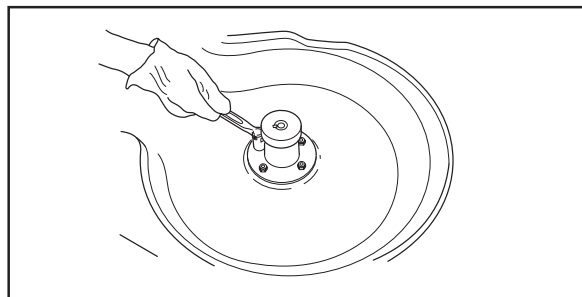

6 Loosen the four screws that hold the blade bearing and remove the entire bearing assembly from the cutting unit.

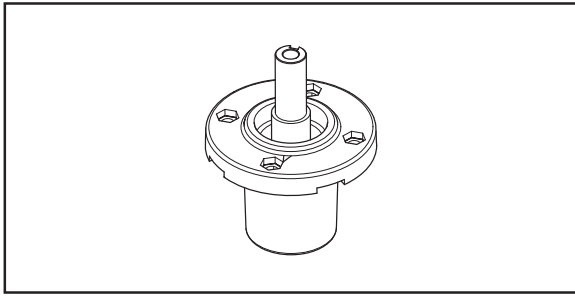

- 7 The whole bearing package is available as a complete kit with shaft housing, shaft and bearings.
 Assembly is done in reverse order to dismantling.
 The blade bolt tightening torque is 45-50 Nm (32-36 lb ft).

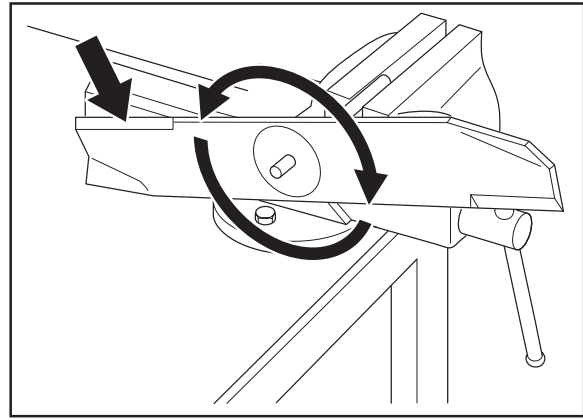

- 3 Balance the blades as follows:
- Put e.g. a drift horizontally in a vice as illustrated.
 - Insert the end of the drift into the center hole of the blade and check that the blade is in equilibrium. The illustration shows a blade that requires adjustment, it must be grinded more to attain the right balance (at the arrow).
 - Assembly is done in reverse order to removal.

Grinding and Balancing Blades

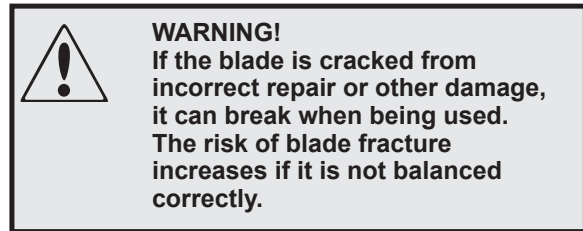
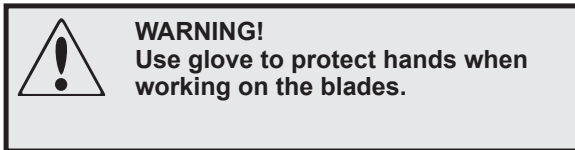

- 1 Remove the blades as described in the previous section.

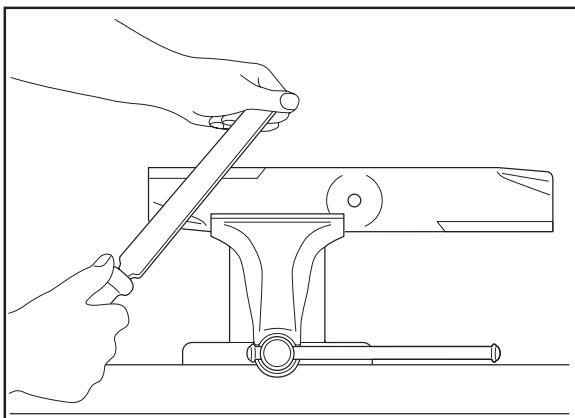

- 2 Fasten the blades in a vice and sharpen with a file.

Electrical System

Wiring diagram

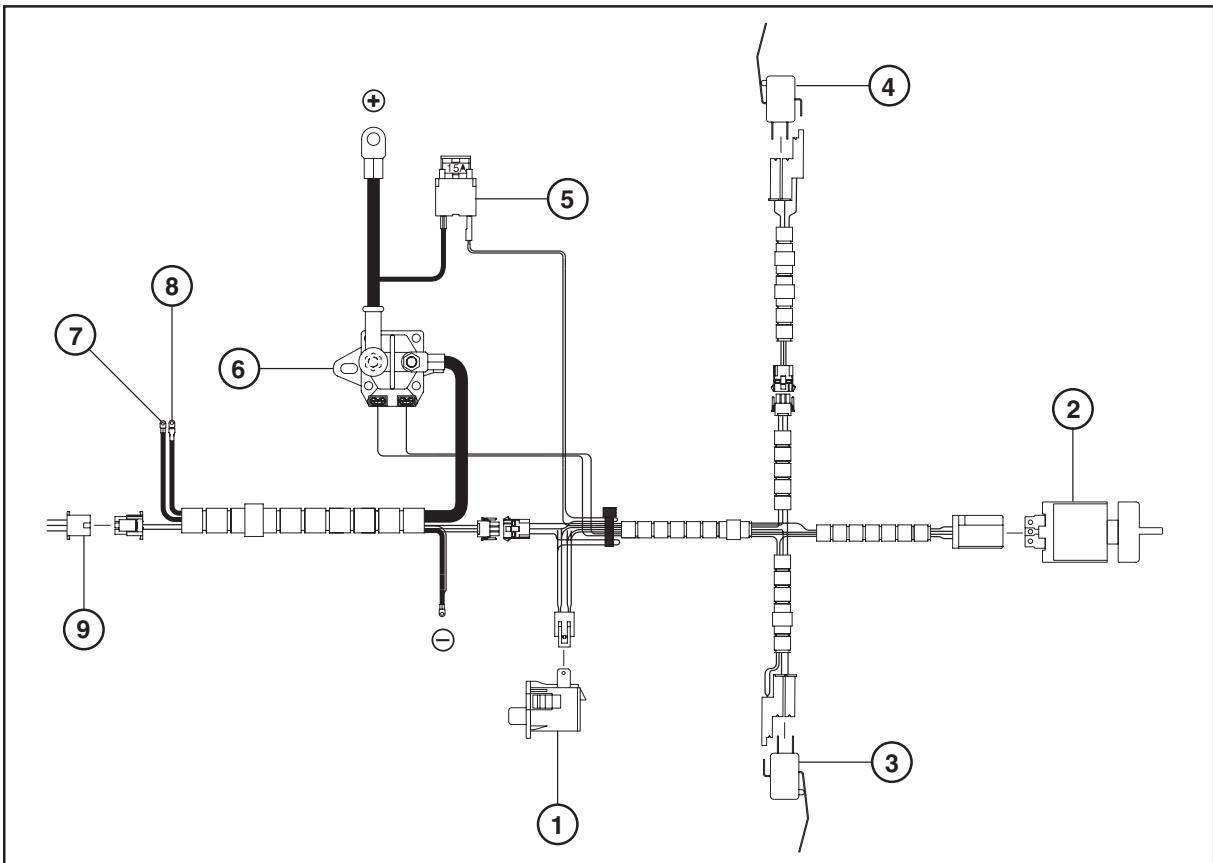
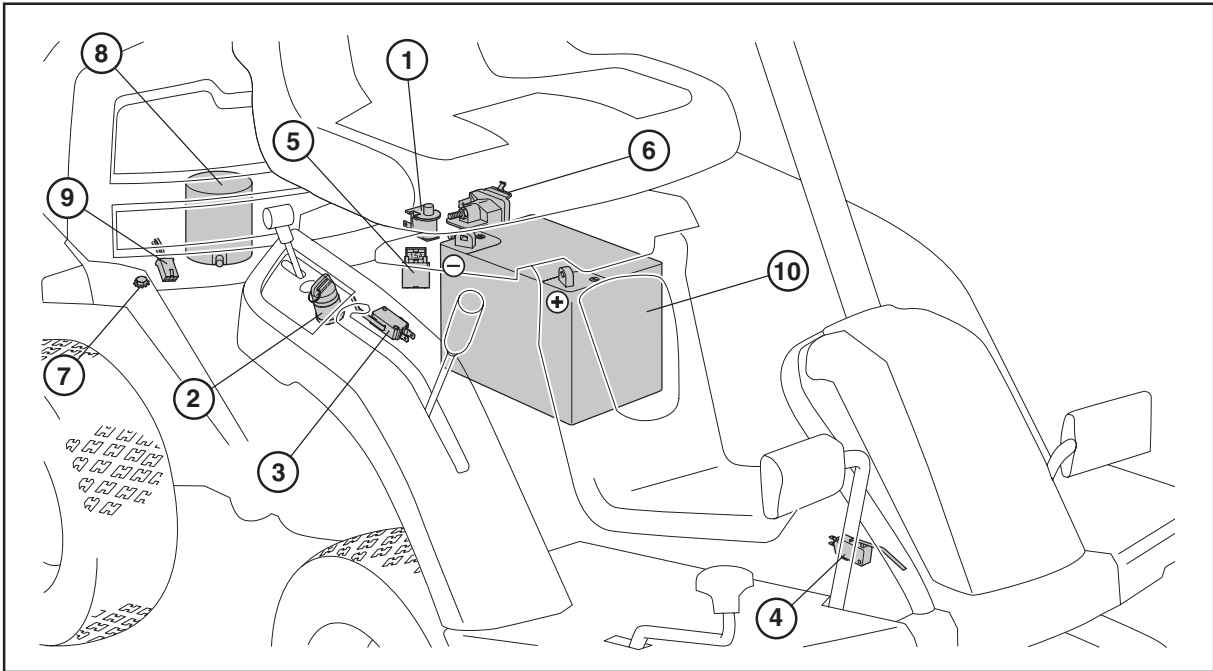

- | | |
|-------------------------------|-------------------------------|
| 1. Microswitch, seat | 6. Starter relay |
| 2. Ignition switch | 7. Grounding point engine |
| 3. Microswitch, lifting lever | 8. Starter motor |
| 4. Microswitch, pedal | 9. Solenoid valve carburettor |
| 5. Fuse, 15A | 10. Battery |

Electrical system components

The electrical system consists of four cables, three microswitches, one ignition switch and one fuse. If the Rider does not start (the start engine does not rotate when the key switch is turned to the starting position), one of the electrical system components might be damaged. A description of how to replace these components is found below.

Microswitch seat

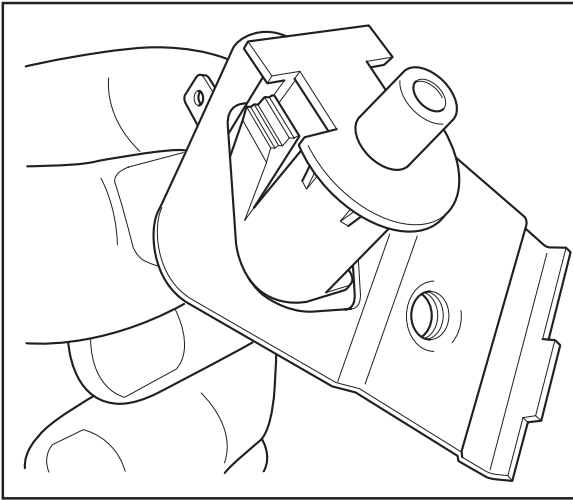

- 1 Fold the seat upwards and remove the spring disc with spring and spacer tube.
- 2 Unplug the cable connections from the microswitch.
- 3 Press in the fasteners and remove the microswitch from the holder.

Assembly is in reverse order.

Microswitch cutting unit

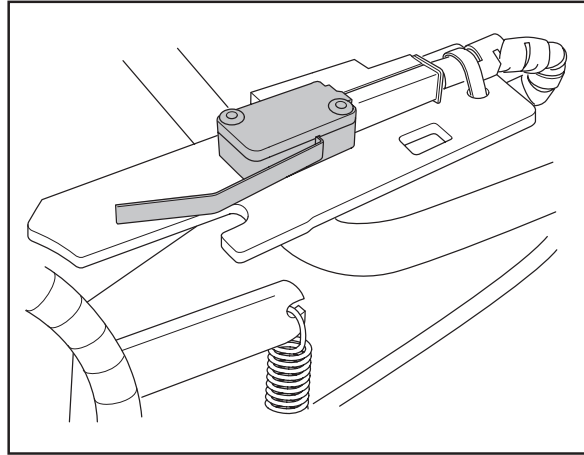

- 1 Loosen the right wing cover.
- 2 Unplug the connector from the microswitch.
- 3 Remove the microswitch.
- 4 Assembly is in reverse order.

Microswitch pedal carrier

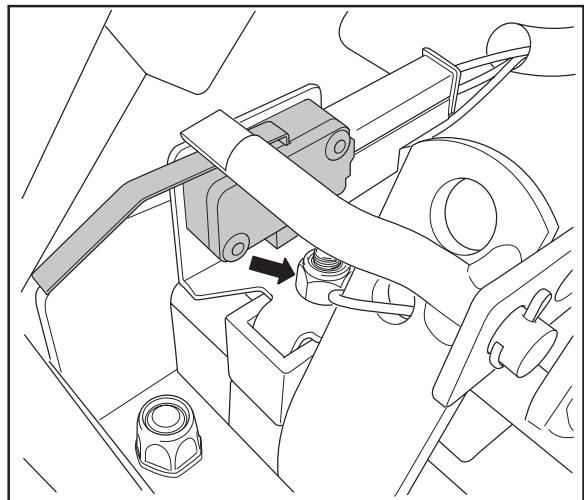

- 1 Remove the front cover.
- 2 Check that the microswitch is activated when the brake pedal is pressed all the way down. Otherwise, replace the microswitch. The switch is held by the screw at the arrow.
- 3 Refit the front cover.

Ignition and starter switch

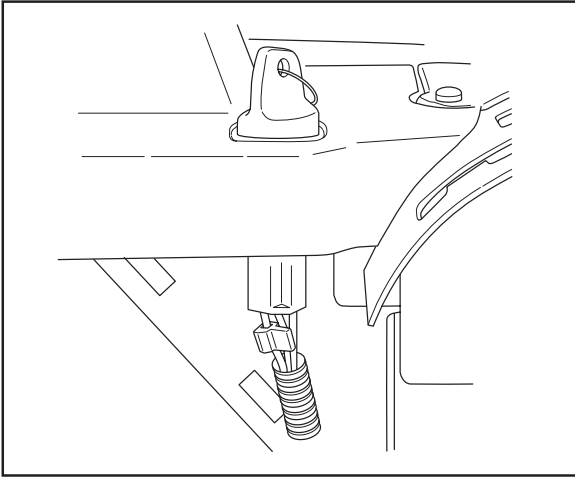

- 1 Unplug the connector from the ignition switch by pulling straight down.
- 2 Remove the ignition key and the rubber seal.
- 3 Remove the nut and the ignition switch.
- 4 Assemble in reverse order. Make sure the connector goes into the right position (click lock).

Main fuse

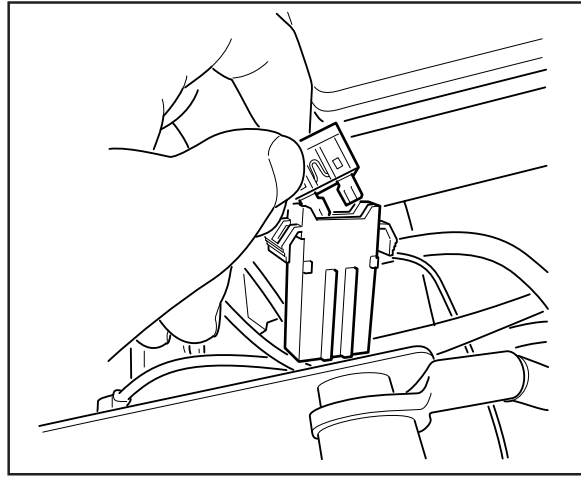

The main fuse is placed in a detachable holder behind the battery under the protective cover.

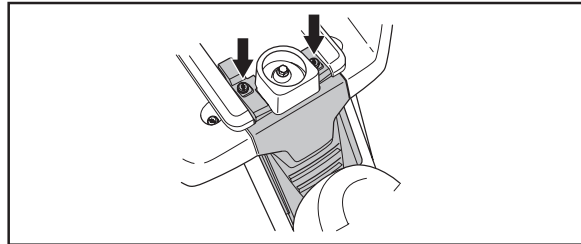

Type: Flat pin, 15 A.

Do not use any other fuse when changing.

A blown fuse is indicated by a burnt link. Pull the fuse from the holder when replacing it.

The fuse is intended to protect the electrical system. If it blows again shortly after replacement, it is due to a short circuit, which must be fixed before the machine can be put into operation again.



www.husqvarna.com

115 73 80-26

2018W44