

Minipave

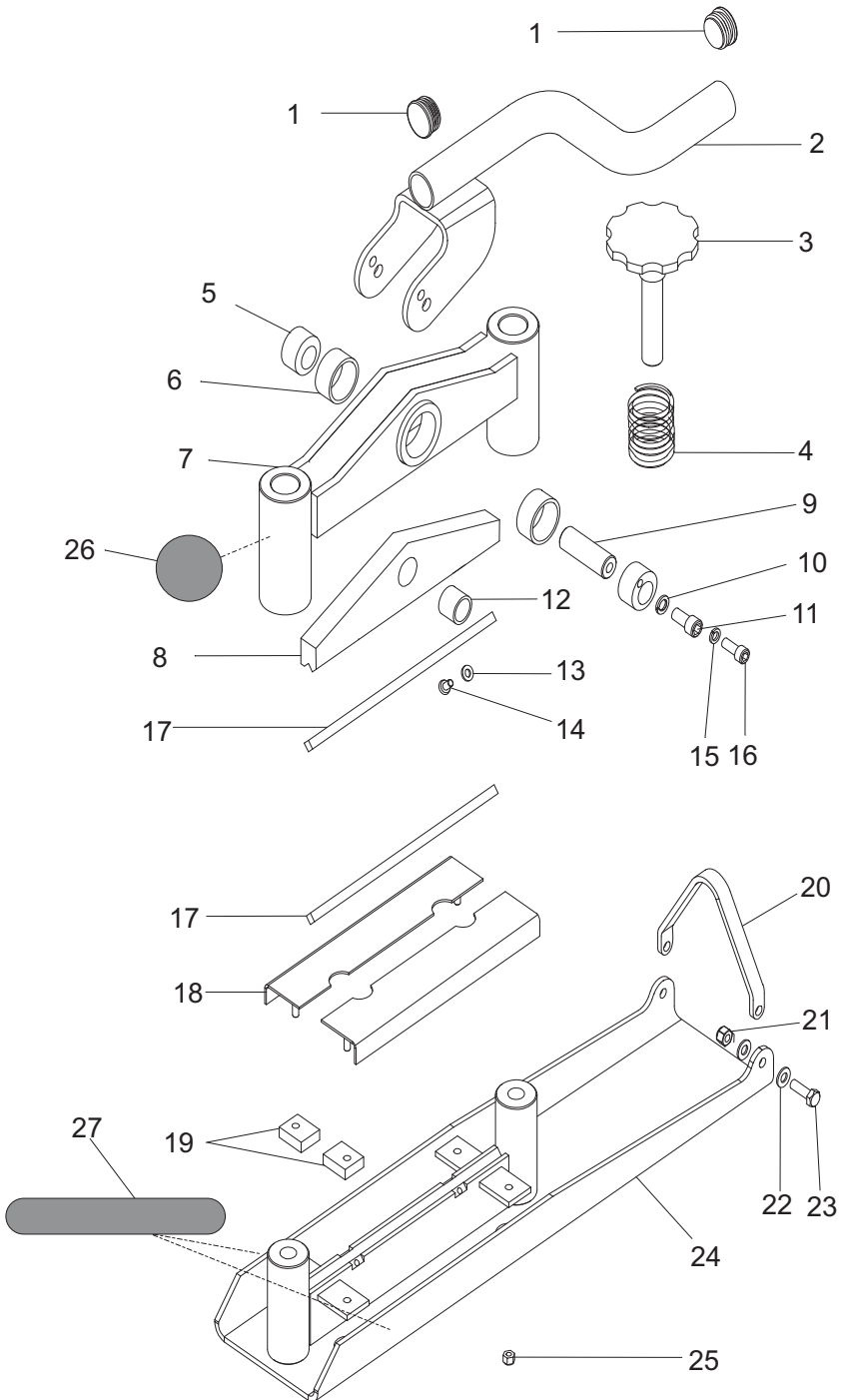

Minipave

Item Number	Part Number	Description	Qty
1	21.0.317	Plastic Insert	2
2	155.0.034	Handle Assembly	1
3	155.0.017	Adjusting Screw Assembly	2
4	155.0.031	Spring	2
5	155.0.023	Cam Actuator	2
6	155.0.028	Bush - Cam Actuator Pivot	2
7	155.0.032	Frame Assembly	1
8	155.0.033	Top Beam Assembly	1
9	155.0.027	Pin - Cam Pivot	1
10	05.1.006	Spring Washer - M10	2
11	07.0.067	Screw - M10 x 20	2
12	155.0.030	Bush - Cam Pivot Pin	1
13	05.0.002	Washer - M6 form A	8
14	02.5.013	Screw - M6 x 12 "pozi-pan"	8
15	05.1.005	Spring Washer - M8	2
16	07.0.009	Screw - M8 x 20	2
17	155.0.025	Blade - Block splitter, 4 way	2
18	155.0.020	Stone Rail Assembly	2
19	155.0.029	Pad - Stone Rail Support, Rubber	4
20	155.0.026	Strap - Handle Retainer	1
21	01.0.104	Nut - M8 hex Nyloc	2
22	05.0.006	Washer - M8 form A	4
23	02.0.025	Setscrew - M8 x 25	2
24	155.0.001	Base Assembly	1
25	01.0.103	Nut - M6 Nyloc	4
26	800/00300	Decal - Belle Logo	1
27	155.0.000	Decal - Minipave	2