

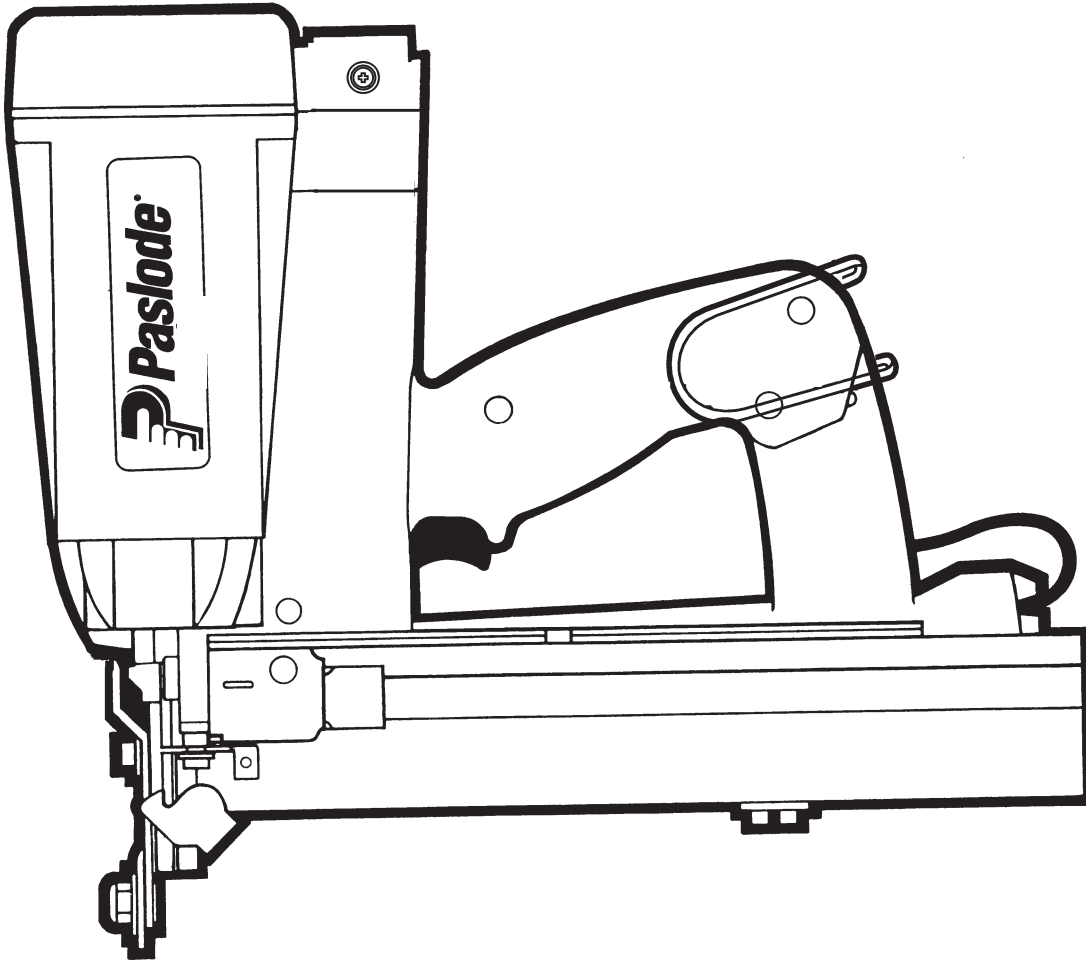

MODEL IM200/50 S16  
CORDLESS STAPLER



**IMPORTANT!**

**DO NOT DESTROY**

Always refer to operators manual #403627 for detailed information on this tool. It is the customer's responsibility to have all operators and service personnel read and understand this information.

**TOOL SCHEMATIC AND PARTS**

# PARTS LEGEND IM200/50 S16 SOLID STATE, 90078

1	900356	1	Grill	58	091532	1	Negator
2	900455	1	Filter	59	091534	1	Drum, Negator
3	901065	4	Shoulder Screw, 10-24 x 1-1/4	60	402743	1	Pin, Negator Drum
4	008388	4	Flat Washer #10	61	402668	1	Retaining Washer
5	900410	1	Cap Assembly	62	402796	1	Follower
6	404427	3	Screw, Taptite, 8-32 x 5/8	63	403104	1	Air Dam
7	006562	3	Washer #8	64	403100	1	Combustion Chamber Assembly
8	900271	1	Circuit Board Assembly	65	403099	1	Retaining Ring, Piston
9	900526	1	Motor & Connector	66	403098	1	Piston Ring
10	403842	1	Spark Plug Boot	*67	404665	1	Piston Driver Blade Assembly
11	401341	1	Spark Plug Assembly	68	403094	1	Bumper
12	401356	1	Sleeve, Motor	69	403084	1	Sleeve/ Midcheck Ring Assembly
13	900470	1	Motor Mount Assembly	70	403089	1	Seal Washer
14	401355	1	Retaining Ring	71	403090	2	Wave Washer
15	403146	1	Stem Adapter (Yellow)	72	403092	2	Retaining Ring, Midcheck
16	900004	1	Cylinder Head	73	403091	1	Muffler
*17	404700	2	O-Ring	74	404339	1	Spring, Chamber Return
18	403167	1	Fan Blade Assembly	75	403106	1	Cage
19	900011	1	Battery Contact Assembly	76	403713	3	E-Ring, Retaining
20	900968	2	Shoulder Screw, 10-32 x 9/16	77	404316	1	Flange, Sleeve
22	404432	1	Bushing, Actuator	78	900411	1	Housing Assembly
23	900357	1	Actuator	▲80	004174	2	S. H. C. S. 10-24 x 7/8
24	404433	1	Pin, Actuator	81	900534	2	S. H. C. S. 10-32 x 5/8
25	900136	1	Actuator Assembly	82	092037	1	Locknut, 10-32
27	900179	1	Handle Right Side	83	402736	1	Washer, Flat #10 Black
28	403156	1	Lanyard	84	404319	1	Lower Work Contacting Element
29	403155	1	Battery Cap	85	900056	1	No-Mar Tip (Optional)
30	900138	1	Handle, Left Side	86	004238	1	Lockwasher #10
32	900453	3	Thrd. Frm.Screw, 8-16 x 7/8	87	402629	1	Washer, Hardened #10
33	900289	1	Belt Hook	88	900535	1	Upper Work Contacting Element
34	901221	1	Screw, 8-32 x 9/16	89	404365	1	Front Guide
35	403082	1	Washer	▲90	900537	2	S. H. C. S. 10-24 x .813
36	403166	1	Bushing	91	900550	1	Back Plate
37	401450	2	Pad, Fuel Cell	92	403822	1	Pivot Pin
38	402201	2	Screw, Phillips Head, 2-56 x 5/8	93	900001	1	Spring, Latch
39	404490	1	Trigger Switch Assembly	94	404317	1	Latch, Front Guide
40	401395	1	Spring	95	092176	1	Roll Pin, 5/32 Dia. x 1-3/8
41	900358	1	Trigger	96	404315	1	Flange, Nose
42	403127	1	Retention Cap	97	900583	1	Removable Spark Plug Wire
43	001641	1	Nut, 8-32	98	900280	1	Spark Assembly
44	900562	1	S. H. C. S. 10-24 x 1-1/8"	99	900509	1	Nameplate
45	900552	2	Cover Plate	100	404385	1	Light Pipe
▲46	004224	5	Screw	**101	900496	1	Warning Label
47	900549	1	Rail Bracket	103	900651	2	Label, Logo
48	404698	2	Roll Pin Assembly	**104	900517	1	International Warning Label
49	900551	1	Pivoting Rail Cover Assembly	106	900232	1	Cable Clamp
50	900548	1	Rail & Cover Assembly	107	404601	1	Head Switch Assembly
51	900532	1	Lower Siding W. C.E.	108	900166	1	Spring, Combusion Chamber
▲52	402797	1	Retaining Bushing	109	900164	1	Ring, Head Switch Activating
53	402798	1	Latch, Follower Button	110	900182	2	Washer, Trigger
54	402799	1	Spring, Follower Latch	111	900142	1	Label, Battery
55	402740	1	Roll Pin, 3/32 x 7/16	112	900236	1	Clip Handle
56	091568	1	Screw, Pan Head, 6-32 x 1/4	114	900300	1	Retaining Ring
57	070545	1	Lockwasher #6	115	900468	1	Washer

\* Denotes normal wear items.

\*\* Make sure warning labels are properly affixed, replace if necessary. Labels available at no charge through the Service Department.

▲ Apply Loctite 242 (Blue).

→ Denotes new change.

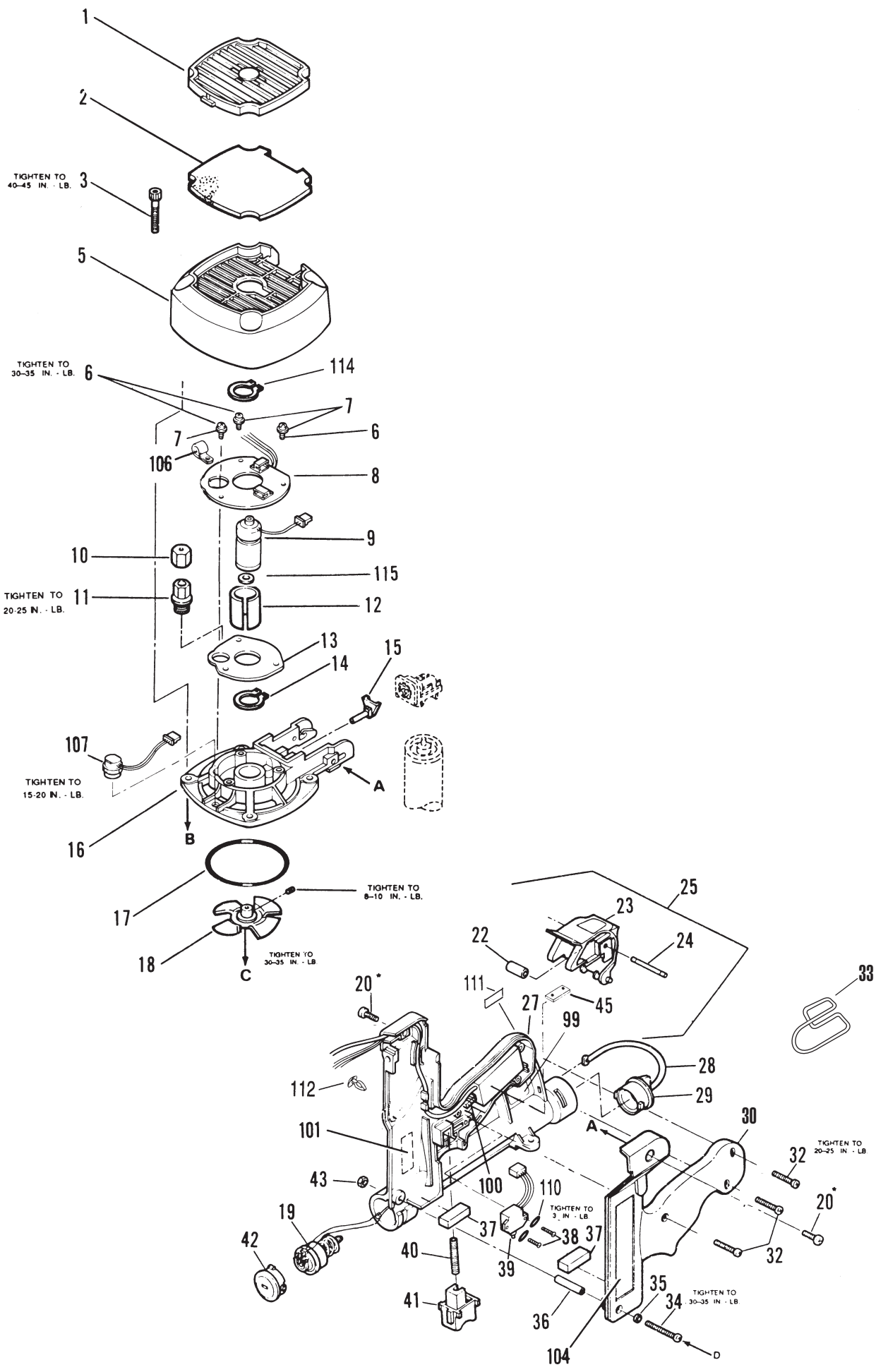

**IM200/50 S16  
SOLID STATE  
900078**

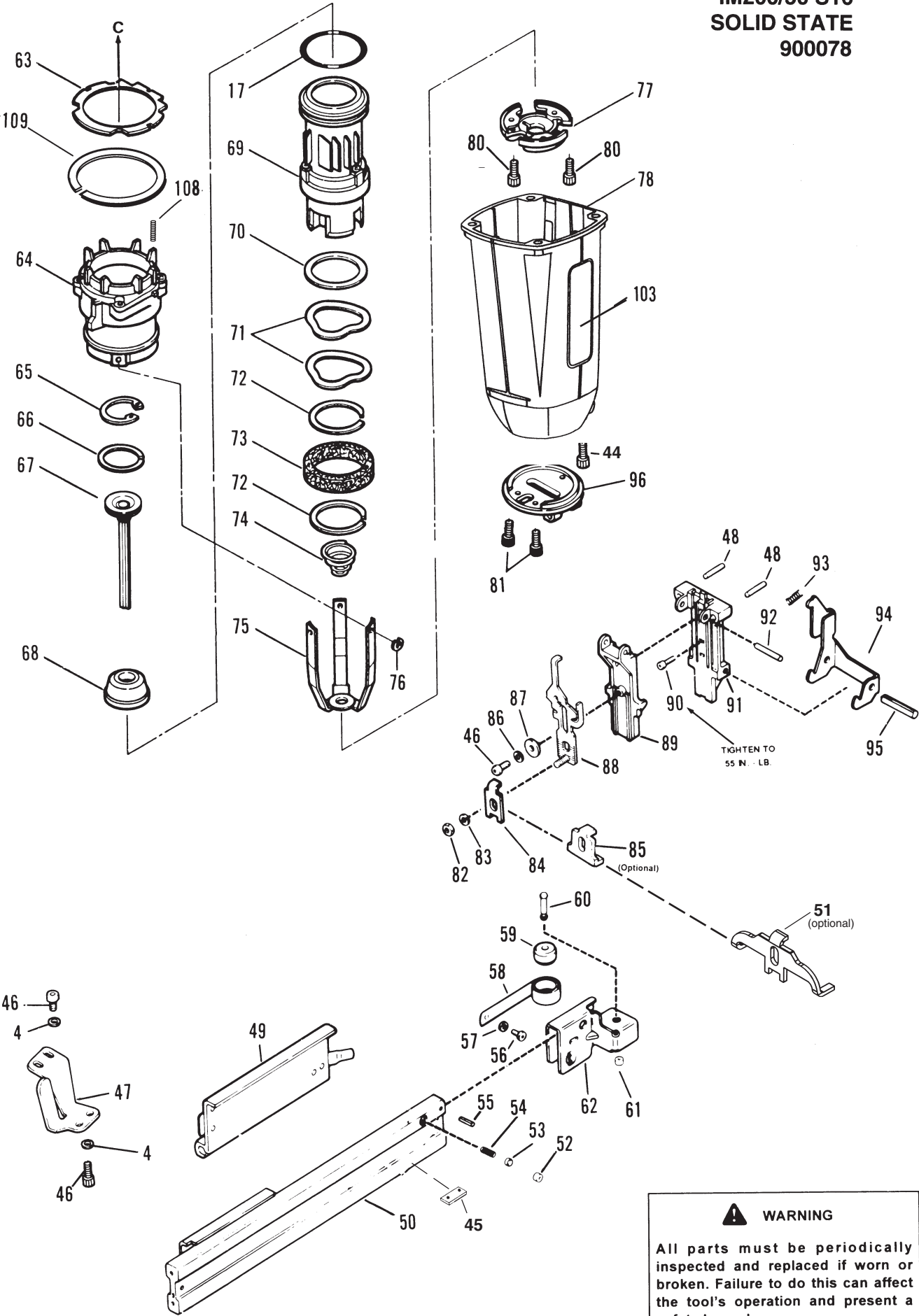

**⚠ WARNING**

All parts must be periodically inspected and replaced if worn or broken. Failure to do this can affect the tool's operation and present a safety hazard.

# ACCESSORIES

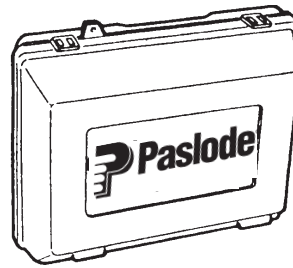

## Impulse Stapler Case

Part No. 403164

---

## Service Tool Kit

A 19 piece tool kit containing all the necessary tools to repair any Paslode Cordless Tool

Part No. 401498

---

## Battery Cell



Part No. 402500

---

## Impulse Oil



Part No. 401482

---

## Torx Key

For tightening fan blade to motor



Part No. 900183

---

## Battery Charger Kit

(Replacement Charger Base Only Part No. 900476)  
(Replacement Transformer Only Part No. 900477)

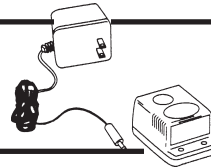

Part No. 900200

---

## Clear Safety Glasses

Part No. 402510

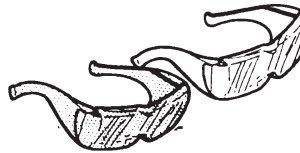

## Tinted Safety Glasses

Part No. 402512

---

## Degreaser Cleaner

Ideal cleaner for all Paslode tools

Part No. 219086

---



An Illinois Tool Works Company  
888 Forest Edge Drive  
Vernon Hills, Illinois 60061

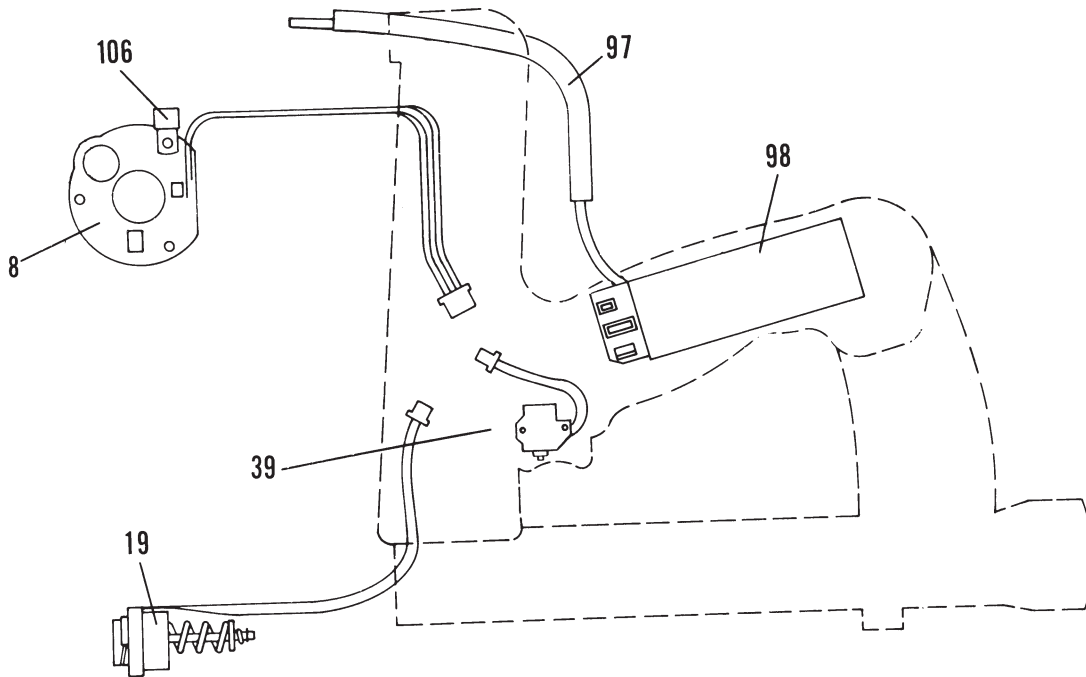

## SAFETY INSTRUCTIONS

	<b>WARNING</b>
	<p>Always wear EYE and EAR safety gear when working with or in the vicinity of the Paslode Cordless Stapler.</p>

	<b>WARNING</b>
	<p>The Paslode Cordless Stapler should be operated only when it is in contact with the work surface. When fastening thin materials such as plywood, be sure to position the tool so that the fastener is driven into the underlying piece.</p>

1. WEAR EYE AND EAR PROTECTION.
2. ALWAYS ASSUME THE TOOL IS "LOADED".
3. OPERATE THE TOOL ONLY ON THE WORK SURFACE.
4. NEVER REMOVE OR DISABLE THE WORK CONTACTING ELEMENT.

This device helps reduce the possibility of accidental fastener discharge by preventing the tool from operating until it is completely against the work surface.

NEVER operate the tool if the work contacting element is not working properly.

5. ALWAYS POINT THE TOOL AWAY FROM YOURSELF AND OTHERS WHEN CLEARING JAMS OR REMOVING FASTENERS.
 

Pull the follower slightly back and push the release lever. Tip the tool nose up slightly and fasteners should slide out of the rear of the magazine. If fasteners are jammed, refer to the appropriate service section of the operating manual.
6. NEVER ATTEMPT TO OPERATE THE PASLODE CORDLESS STAPLER IF PARTS ARE LOOSE, DAMAGED OR MISSING.