

**PASLODE CORDLESS  
FRAMING NAILER**

**TOOL SCHEMATIC AND PARTS**

**IMPORTANT!  
DO NOT DESTROY**

Always refer to operating manual #403608 for detailed information on this tool. It is the customer's responsibility to have all operators and service personnel read and understand this information.

# PARTS LEGEND Paslode CORDLESS FRAMING NAILER, 900420

1	900320	1	Grill	51	404827	2	Pin
*2	900315	1	Filter	*52	404419	1	Bumper
3	900469	1	Fan Motor Assembly (Includes PC board, washer and flat retaining ring)	53	404411	3	Spring
4	900300	1	Retaining Ring (flat)	*54	404482	1	O-Ring
5	006562	3	Lockwasher #8	55	404719	1	Sleeve Assembly
6	900470	1	Motor Mount	56	404464	2	Rubber Stop
7	401355	1	Retaining Ring (curved)	57	404424	1	Reed Valve
8	900348	4	Socket Head Capscrew 10-24 x 1-1/2	58	404422	1	Muffler
9	008388	4	Flat Washer	59	404423	1	Muffler Cover
*10	401356	1	Motor Sleeve	60	404468	4	Lock Washer
11	900286	1	Spark Plug Assembly, includes O-Ring	61	404722	4	Screw, Thread Forming 8-32 x 7/16
12	404428	2	Push Rod	62	403816	2	Socket Head Capscrew 10 - 24 x 1-1/8
13	404453	1	Bracket, Cylinder Head	63	404445	2	Bushing, Shear Lock
14	404432	1	Bushing, Actuator	64	404417	1	Wear Plate, Nose
15	404444	1	Actuator	65	404410	1	Upper Probe
16	404433	1	Actuator Pin	66	404413	1	Lower Probe
17	401340	1	Stem Adapter	67	009037	2	Socket Head Capscrew 10 - 32 x 1/2
18	900471	1	Cylinder Head Machined	68	401380	1	Tie Bar
*19	403992	1	O-Ring	69	900425	1	Clamp, Cable
20	403167	1	Fan Blade Assembly	70	404704	1	Housing Assembly
21	900474	1	Spark Unit Assembly	71	900289	1	Belt Hook
22	900475	1	Molded Circuit Assembly	72	404390	2	Label
23	900478	1	Spark Plug Contact Assembly	73	404418	1	Retainer Ring, Sleeve
24	900231	1	Clip, ESU Wire	▲ 74	004618	3	Socket Head Capscrew 10-24 x 5/8
■ 25	403987	2	Screw, thread-forming 6-32 x 1/4	75	403985	1	Follower
26	900461	1	Handle Assembly Kit - Right & Left	76	900520	1	Follower Bushing Spring Assembly
27	404448	1	Roller Lever Assembly	77	900529	1	Retaining Ring
28	404447	1	Flat Washer	78	403986	1	Spring Pin
29	404702	3	Screw, Thread Forming 6 x 3/8	79	403984	1	Follower Guide
30	404436	1	Nail Channel	80	900297	1	Follower Button
31	404441	1	Cover Plate Magazine	81	404457	1	Spring
32	404477	2	Screw 10 - 32 x 1/2	82	404922	2	Pad, Battery Contact
33	900465	1	Cap (with bushings)	83	401450	4	Fuel Cell Pad
34	404412	1	Wear Plate, Chamber Lock	■ 84	405141	2	Screw Torx 8 - 32 x 7/16
35	900453	4	Screw Plastite 8-16 x 7/8	85	900334	1	Cage Stop
** 36	900508	1	Warning Label	86	404426	1	Exhaust Baffle
37	404442	1	Channel Magazine	87	404425	1	Reed Plate
■ 38	013625	4	Socket Head Capscrew 8 - 32 x 1/2	■ 88	900969	4	Torx Screw 8-32 x 5/8
39	404414	4	Flat Washer #8	89	900481	1	O-Ring
40	404451	1	Lockout Bar, Follower	**90	900497	1	Warning Label
➔ 41	900971	1	Shear Block Assembly	91	900372	1	Combustion Chamber Ring
44	404435	1	Trigger	92	404407	1	Combustion Chamber
45	900269	1	Chamber Lock Bar	93	405140	2	Torx Screw 8-32 x 3/8
46	404927	1	Spring, Trigger	94	004238	5	Lock Washer #10
47	401328	1	Retainer ring	➔ 95	900981	1	Nameplate
48	401461	2	Piston Ring	96	900427	1	Light Pipe
49	404485	1	Piston Assembly	97	900468	1	Washer, Motor Shaft
50	900521	1	Combustion Chamber Assembly	98	900349	4	Bushing, Cap

- \* Denotes normal wear items
- \*\* Make sure Warning Labels (#900497,900508) are properly affixed. Replace if necessary. Label is available at no charge through the Service Department.
- ▲ Apply Loctite 242 (Blue) Part No. 093500.
- Apply Loctite RC-620 (Green) Part No. 401491
- ➔ Denotes new change.

## SAFETY INSTRUCTIONS

### WEAR EYE AND HEARING PROTECTION

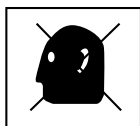

Always wear hearing protection and eye protection devices, including side shields when operating or working in the vicinity of a tool.

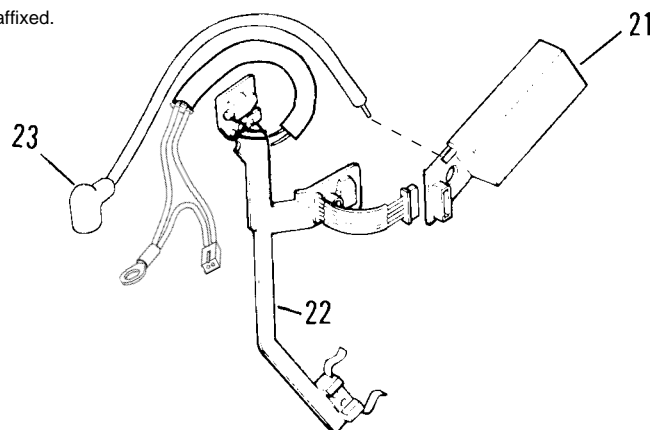
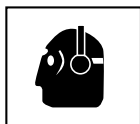

### ⚠ WARNING

All parts must be periodically inspected and replaced if worn or broken. Failure to do this can affect the tool's operation and present a safety hazard.

# CORDLESS FRAMING NAILER, 900420

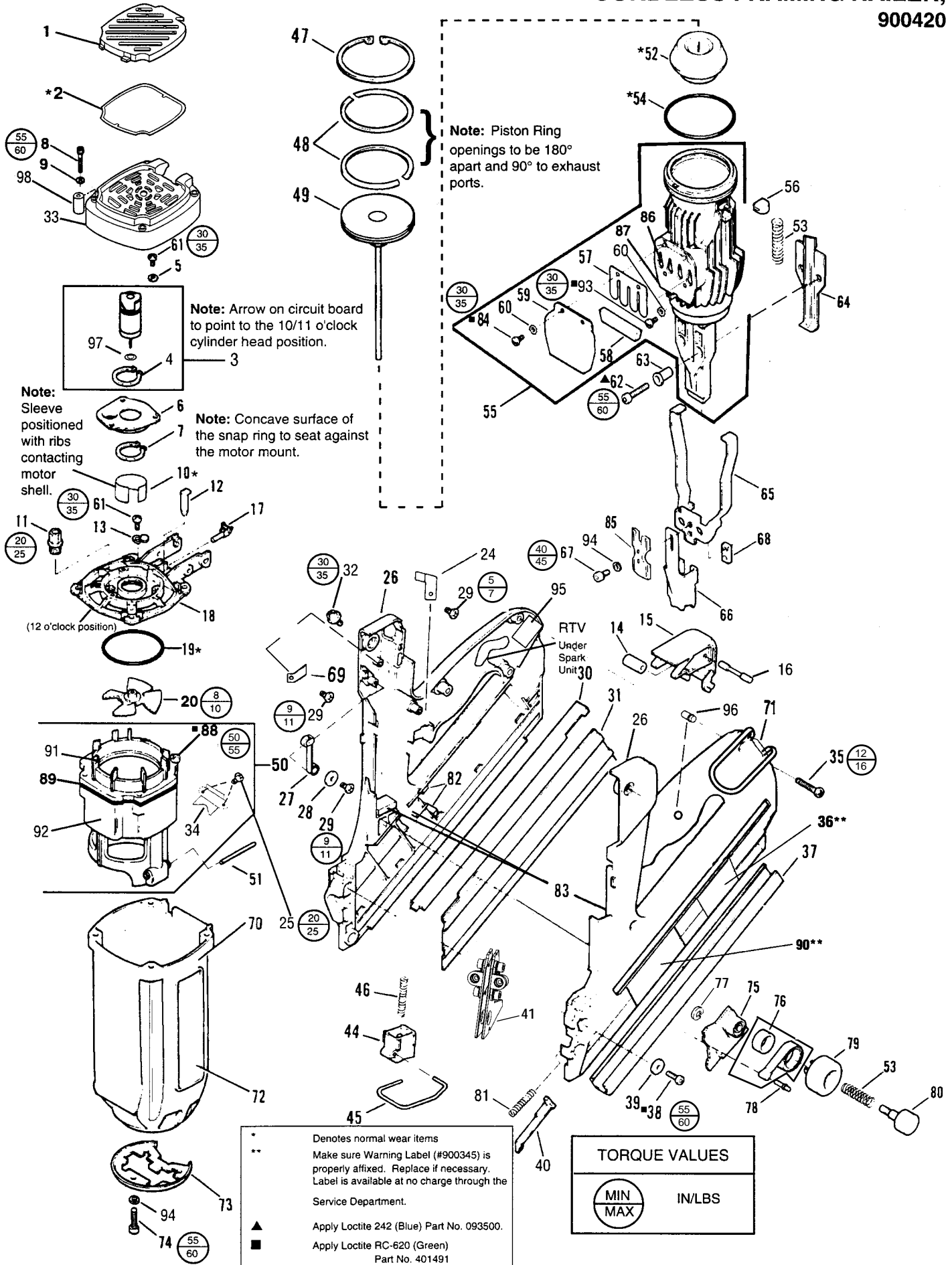

# ACCESSORIES

---

## Car Adapter

Enables you to re-charge your battery with your vehicle's electrical system.

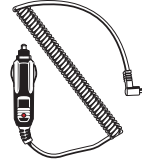

Part No. 900507

---

## Battery Cell



Part No. 404717

---

## Impulse Oil



Part No. 401482

---

## 5/32" Hex Key

For adjusting work contacting element.



Part No. 401331

---

## No-Mar Work Contacting Element

Rubber tipped WCE to eliminate marring work surface.  
(Replacement rubber tip, Part No. 403369)

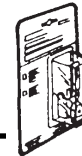

Part No. 404705

---

## Paslode Cordless Nailer Case

Part No. 404710

---

## Clear Safety Glasses

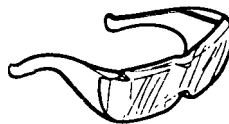

Part No. 402510

---

## Tinted Safety Glasses



Part No. 402512

---

## Degreaser Cleaner

Ideal cleaner for all Paslode® tools.

Part No. 219086

---

## Battery Charger Kit

(Replacement Charger Base Only Part No. 900476)

(Replacement Transformer Only Part No. 900477- US/CANADA)

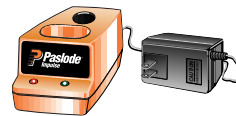

Part No. 900200

(Replacement Transformer Only Part No. 900505 Continental Europe)

(Replacement Transformer Only Part No. 900506 U.K.)

(Replacement Transformer Only Part No. 900504 Australia)



An Illinois Tool Works Company  
888 Forest Edge Drive  
Vernon Hills, Illinois 60061