

STIHL MS 171, 181, 211

2012-10

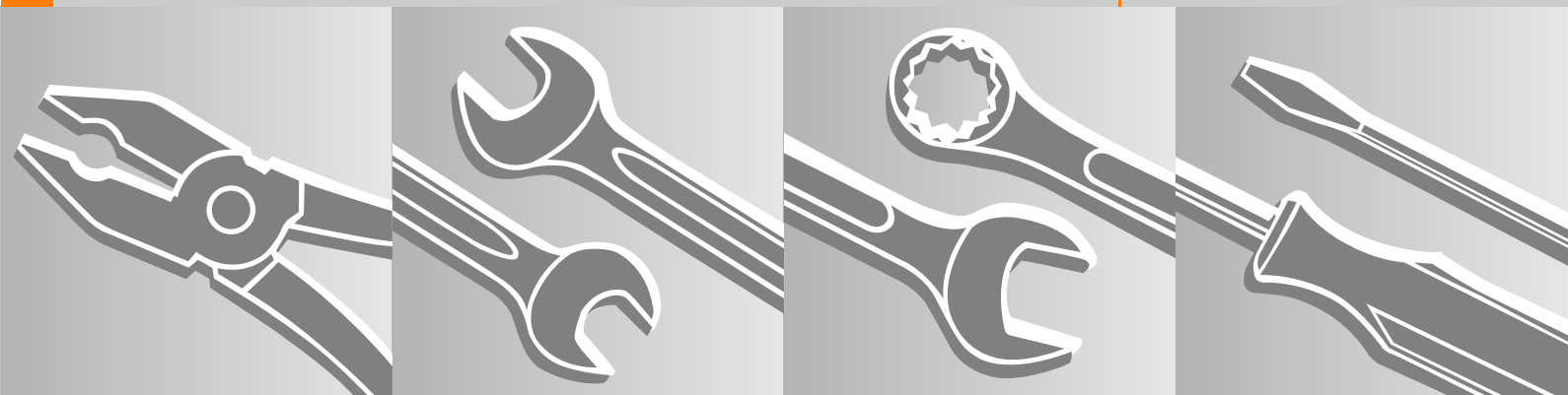

Contents

1.	Introduction	3	8.	Engine	28	11.	Servicing the AV System	60
2.	Safety Precautions	4	8.1	Muffler / Spark Arresting Screen	28	11.1	AV Spring on Oil Tank	60
3.	Specifications	5	8.2	Leakage Test	29	11.2	AV Spring on Fuel Tank	60
3.1	Engine	5	8.2.1	Preparations	29	11.3	AV Spring on Cylinder	61
3.2	Fuel System	5	8.2.2	Vacuum Test	30	11.4	Handle Frame	62
3.3	Ignition System	5	8.2.3	Pressure Test	30			
3.4	Chain Lubrication	5	8.3	Oil Seals	31	12.	Master Control Lever	64
3.5	Tightening Torques	6	8.4	Removing and Installing the Shroud	32	12.1	Switch Shaft	64
4.	Troubleshooting	8	8.5	Removing and Installing the Engine	33	12.1.1	Removing and Installing	64
4.1	Clutch	8	8.6	Crankshaft	34	12.2	Throttle Trigger / Interlock Lever	66
4.2	Chain Drive, Chain Brake, Chain Tensioner	9	8.7	Ball Bearings/ Crankshaft	36			
4.3	Chain Lubrication	10	8.8	Piston	37	13.	Chain Lubrication	68
4.4	Rewind Starter	11	8.8.1	Piston Rings	39	13.1	Pickup Body	68
4.5	Ignition System	12	9.	Ignition System	40	13.2	Oil Suction Hose	68
4.6	Carburetor	14	9.1	Ignition Module	40	13.3	Removing and Installing the Oil Pump	69
4.7	Engine	17	9.1.1	Removing and Installing	40	13.4	Valve	70
5.	Cutting Attachment	18	9.2	Ignition Timing	42	13.5	Oil Tank Cap	71
5.1	Chain Catcher	18	9.3	Testing the Ignition Module	42			
6.	Clutch	19	9.4	Spark Plug Boot	43			
6.1	Clutch Drum	21	9.5	Flywheel	44			
7.	Chain Brake	22	9.6	Short Circuit Wire	45			
7.1	Checking Operation	22	9.6.1	Testing	45			
7.2	Removing and Installing the Brake Band	22	9.6.2	Removing and Installing	45			
7.3	Brake Lever	24	9.6.3	Ground Wire	47			
7.4	Flat Spring	26	9.6.4	Contact Spring	47			
7.5	Pins	26	9.7	Ignition System Troubleshooting	49			
7.6	Chain Tensioner	27	10.	Rewind Starter	52			
7.7	Bar Mounting Studs	27	10.1	General	52			
			10.2	Removing and Installing	52			
			10.3	Pawl	53			
			10.4	ErgoStart	53			
			10.5	Rope Rotor	55			
			10.6	Starter Rope / Grip	55			
			10.7	Tensioning the Rewind Spring	57			
			10.8	Replacing the Rewind Spring	58			

RA_533_00_01_04

Contents

14.	Fuel System	72
14.1	Air Filter	72
14.2	Baffle / Filter Base	72
14.3	Removing and Installing the Carburetor	73
14.3.1	Leakage Test	74
14.4	Servicing the Carburetor	74
14.4.1	Metering Diaphragm	74
14.4.2	Inlet Needle	76
14.4.3	Fixed Jet	76
14.4.4	Valve Jet	77
14.4.5	Pump Diaphragm	77
14.4.6	Air Valve	79
14.4.7	Choke Shaft / Choke Shutter	80
14.4.8	Throttle Shaft / Throttle Shutter	82
14.4.9	Adjusting Screws	85
14.5	Adjusting the Carburetor	86
14.5.1	Basic Setting	86
14.5.2	Standard Setting	87
14.6	Choke and Throttle Rods	87
14.7	Removing and Installing the Intake Manifold	89
14.7.1	Removing and Installing the Carburetor Carrier	90
14.8	Tank Vent	92
14.8.1	Testing	92
14.8.2	Removing and Installing	93
14.8.3	Manual Fuel Pump	93
14.9	Fuel Intake	94
14.9.1	Pickup Body	94
14.9.2	Fuel Intake Hoses	95
14.9.3	Fuel Hoses, Tank Vent / Manual Fuel Pump	96
14.9.4	Fuel Tank Cap	97
15.	Special Servicing Tools	98
16.	Servicing Aids	100

1. Introduction

This service manual contains detailed descriptions of all the typical repair and servicing procedures for this power tool.

You should make use of the illustrated parts lists while carrying out repair work. They show the installed positions of the individual components and assemblies.

Refer to the latest edition of the relevant parts list to check the part numbers of any replacement parts.

A fault on the machine may have several causes. To help locate the fault, consult the chapter on "Troubleshooting" and the "STIHL Service Training System" for all assemblies.

Refer to the "Technical Information" bulletins for engineering changes which have been introduced since publication of this service manual. Technical information bulletins also supplement the parts list until an updated edition is issued.

The special tools mentioned in the descriptions are listed in chapter "Special Servicing Tools" of this manual. Use the part numbers to identify the tools in the "STIHL Special Tools" manual which lists all the special servicing tools currently available from STIHL.

Symbols are included in the text and pictures for greater clarity. The meanings are as follows:

In the descriptions:

- = Action to be taken as shown in the illustration (above the text)
- = Action to be taken that is not shown in the illustration (above the text)

In the illustrations:

- ➔ Pointer
- ➔ Direction of movement
- 📖 4.2 = Reference to another chapter, i.e. chapter 4.2 in this example

Service manuals and technical information bulletins are intended exclusively for the use of properly equipped repair shops. They must not be passed to third parties.

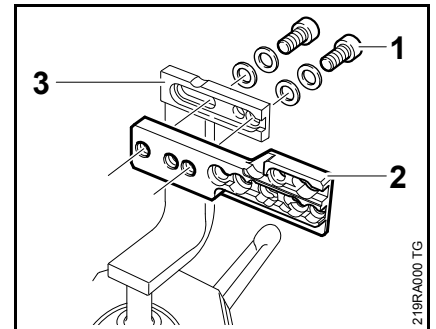

Servicing and repairs are made considerably easier if the machine is mounted to assembly stand (3) 5910 890 3100. To do this, secure the mounting plate (2) 5910 850 1650 to the assembly stand with two screws (1).

The screws must not project since they, depending on the machine, may damage housings when the machine is clamped in position.

The above operation is not necessary with the new assembly stand 5910 890 3101 since the mounting plate is already fitted.

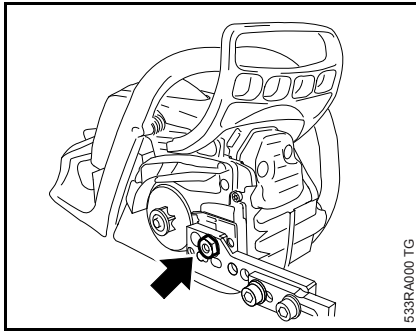

After disengaging the chain brake and removing the chain sprocket cover, bar and chain, the powerhead's bar stud is pushed through the outer hole in the mounting plate and secured with the nut (arrow).

The machine is held in position on the mounting plate by the two screw heads on the engine housing.

Always use original STIHL replacement parts. They can be identified by the STIHL part number, the **STIHL** logo and the STIHL parts symbol . This symbol may appear alone on small parts.

Storing and disposing of oils and fuels

Collect fuel or lubricating oil in a clean container and dispose of it properly in accordance with local environmental regulations.

2. Safety Precautions

If the engine is started up in the course of repairs or maintenance work, observe all local and country-specific safety regulations as well as the safety precautions and warnings in the instruction manual.

Gasoline is an extremely flammable fuel and can be explosive in certain conditions.

Always wear suitable protective gloves for operations in which components are heated for assembly or disassembly.

Improper handling may result in burns or other serious injuries.

Do not bring any fire, flame, spark or other source of heat near the fuel. All work with fuel must be performed outdoors only. Spilled fuel must be wiped away immediately.

Always perform leakage test after working on the fuel system and the engine.

3. Specifications

3.1 Engine

	MS 171	MS 181, MS 181 C	MS 211, MS 211 C
Displacement:	30.1 cm ³	31.8 cm ³	35.2 cm ³
Bore:	37 mm	38 mm	40 mm
Stroke:	28 mm	28 mm	28 mm
Engine power to ISO 7293:	1.3 kW (1.8 PS) at 9,500 rpm	1.5 kW (2.0 PS) at 9,500 rpm	1.7 kW (2.3 PS) at 9,500 rpm
Max. permissible engine speed with bar and chain:	13,500 rpm	13,500 rpm	13,500 rpm
Idle speed:	2,800 rpm	2,800 rpm	2,800 rpm
Clutch:	Centrifugal clutch without linings		
Clutch engages at:	5,100 rpm	5,100 rpm	5,100 rpm
Crankcase leakage test at gauge pressure:	0.5 bar		
under vacuum:	0.5 bar		
<hr/>			
3.2 Fuel System	Carburetor leakage test at gauge pressure:		0.8 bar
	Operation of tank vent at gauge pressure:		0.5 bar
	Fuel:	as specified in instruction manual	
<hr/>			
3.3 Ignition System	Air gap between ignition module and fanwheel:		0.15...0.35 mm
	Spark plug (suppressed):		NGK CMR 6H
	Electrode gap:		0.5 mm
<hr/>			
3.4 Chain Lubrication	Fully automatic, speed-controlled oil pump with reciprocating piston		
	Oil delivery rate:		7.0 cm ³ /min at 10,000 rpm

3.5 Tightening Torques

DG and P (Plastoform) screws are used in polymer and light metal components. These screws form a permanent thread when they are installed for the first time. They can be removed and installed as often as necessary without impairing the strength of the screwed assembly, providing the specified tightening torque is observed.

For this reason it is **essential to use a torque wrench**.

Fastener	Thread size	For component	Torque	Remarks
			Nm	
Screw	P 4x12	Cover plate, chain sprocket cover	2.5	
Screw	B 3.9x13	Cover plate (special accessory)	1.0	
Screw	D 4x15	Chain tensioner cover/engine housing	2.5	
Collar screw	D 8x18	Collar screw, engine housing/guide bar, rear	16.0	1)
Collar screw	D 8x18	Collar screw engine housing/guide bar, front	16.0	1)
Screw	P 4x16	Cover, chain brake/engine housing (repair solution)	2.0	
Screw	D 5x16	Cover, chain brake/engine housing (repair solution)	2.0	
Countersunk screw	M 6x14	Replacement chain catcher (repair solution)	4.0	
Screw	P 5x20	Filter base/engine housing	4.0	
Screw	P 5x20	Filter base/engine housing/carburetor carrier	4.0	
Screw	D 5x16	Spiked bumper/engine housing	3.5	
Screw	D 4x12	Manifold/cylinder	4.0	
Screw	P 5x20	AV bearing plug, front bottom/engine housing	4.0	
Screw	P 5x20	AV bearing plug, rear bottom/handle frame	4.0	
Screw	P 5x20	AV bearing plug, rear bottom/engine housing	4.0	
Screw	D 5x18	AV bearing plug/cylinder	8.0	
Screw	P 5x25	Fan housing/hand guard/engine housing	4.0	
Screw	P 5x20	Fan housing/engine housing	4.0	
	M 12x1 L	Clutch/crankshaft	50.0	
Screw	D 5.3x41	Crankcase/engine pan/cylinder	11.0	
Collar nut	M 5	Baffle/filter base/collar screw, carburetor	3.5	
Screw	D 5x18	Muffler/cylinder	8.0	
Nut	M 8x1	Flywheel/crankshaft	28.0	2)
	M 10x1	Spark plug	12.0	
Screw	D 4x18	Ignition module/cylinder	4.0	

Remarks:

- 1) Loctite 243 medium strength
 - 2) Degrease crankshaft/flywheel faces and mount oil-free
-

Use the following procedure when refitting a DG or P screw in an existing thread:

Place the screw in the hole and rotate it counterclockwise until it drops down slightly.
Tighten the screw clockwise to the specified torque.

This procedure ensures that the screw engages properly in the existing thread and does not form a new thread and weaken the assembly.

Power screwdriver setting for polymer: DG and P screws max. 500 rpm
Do not use a impact wrench for releasing or tightening screws.

Do not mix up screws with and without binding head

4. Troubleshooting

4.1 Clutch

Condition	Cause	Remedy
Saw chain stops under load at full throttle	Clutch shoes badly worn	Install new clutch
	Clutch drum badly worn	Install new clutch drum
Saw chain rotates at idle speed	Engine idle speed too high	Readjust with idle speed screw (LA) (counterclockwise)
	Clutch springs stretched or fatigued	Replace the clutch springs or install new clutch
	Clutch spring hooks broken	Replace the clutch springs
	Clutch shoe bores worn	Replace clutch shoes or install new clutch
Loud noises	Clutch springs stretched or fatigued	Replace all clutch springs
	Needle cage damaged	Fit new needle cage
	Clutch shoe retainer broken	Fit new retainer
	Clutch shoes and carrier worn	Install new clutch

4.2 Chain Drive, Chain Brake, Chain Tensioner

Condition	Cause	Remedy
Chain sprocket wears rapidly	Chain not properly tensioned	Tension chain as specified
	Wrong chain pitch	Fit chain of correct pitch
	Insufficient chain lubrication	Check chain lubrication
	Chain sprocket worn	Fit new chain sprocket
Saw chain stops under load at full throttle	Clutch shoes badly worn	Install new clutch
	Clutch drum badly worn	Install new clutch drum
	Brake band blocked	Check freedom of movement and operation of brake band
Saw chain does not stop immediately when brake is activated	Brake spring stretched or broken	Fit new brake spring
	Brake band stretched or worn	Fit new brake band
	Clutch drum worn	Fit new clutch drum

4.3 Chain Lubrication

In the event of trouble with the chain lubrication system, check and rectify other sources of faults before disassembling the oil pump.

Condition	Cause	Remedy
Chain receives no oil	Oil tank empty	Fill up with oil, check oil pump
	Oil inlet hole in guide bar is blocked	Clean oil inlet hole
	Intake hose or pickup body clogged or intake hose ruptured	Fit new intake hose and pickup body
	Valve in oil tank blocked	Clean or replace valve
	Teeth on worm worn	Install new worm
	Oil pump damaged or worn	Install new oil pump
	Oil intake hose not properly fitted or damaged	Fit oil intake hose properly or install new hose
Machine losing chain oil	Oil pump body (engine housing) damaged	Check engine housing and oil pump and replace if necessary
	Oil pump damaged or worn	Install new oil pump
	Oil intake hose connector damaged	Install new oil intake hose
	Oil intake hose not properly fitted or damaged	Fit oil intake hose properly or install new hose
Oil pump delivers insufficient oil	Oil pump worn	Install new oil pump
	Oil intake hose not properly fitted or damaged	Fit oil intake hose properly or install new hose
	Unsuitable chain lubricant has been used	Drain unsuitable chain lubricant from oil tank and fill up with recommended chain lubricant

4.4 Rewind Starter

Condition	Cause	Remedy
Starter rope broken	Rope pulled out too vigorously as far as stop or over edge, i.e. not vertically	Fit new starter rope
	Normal wear	Fit new starter rope
Starter rope does not rewind	Very dirty or corroded	Clean or replace rewind spring
	Insufficient spring tension	Check rewind spring and increase tension
	Rewind spring worn	Fit new rewind spring
Starter rope cannot be pulled out far enough	Spring overtensioned	Check rewind spring and reduce tension
Starter rope can be pulled out almost without resistance (crankshaft does not turn)	Guide peg on pawl or pawl itself is worn	Fit new pawl
	Spring clip on pawl fatigued	Fit new spring clip
Versions with ErgoStart	Spring worn or fatigued	Fit new ErgoStart spring housing
	Carriers or pawls on flywheel faulty	Install new ErgoStart carriers or pawls
Starter rope is difficult to pull and rewinds very slowly	Starter mechanism is very dirty	Thoroughly clean complete starter mechanism
	Lubricating oil on rewind spring becomes viscous at very low outside temperatures (spring windings stick together)	Coat rewind spring with a little standard solvent-based degreasant (containing no chlorinated or halogenated hydrocarbons), then pull rope carefully several times until normal action is restored

4.5 Ignition System

Exercise extreme caution while carrying out maintenance and repair work on the ignition system. The high voltages which occur can cause serious or fatal accidents!.

Condition	Cause	Remedy
Engine runs roughly, misfires, temporary loss of power	Spark plug boot is loose	Press boot firmly onto spark plug and fit new spring if necessary
	Spark plug sooted, smeared with oil	Clean the spark plug or replace if necessary
	Fuel/oil mixture – too much oil	Use correct mixture of fuel and oil
	Incorrect air gap between ignition module and flywheel	Set air gap correctly
	Flywheel cracked or has other damage or pole shoes have turned blue	Install new flywheel
	Ignition timing wrong, flywheel out of adjustment, key in flywheel has sheared off	Install new flywheel
	Weak magnetization in flywheel – pole shoes have turned blue	Install new flywheel
	Irregular spark	Check operation of switch shaft/contact springs and ignition module. Faulty insulation or break in ignition lead or short circuit wire. Check ignition lead/ignition module and replace ignition module if necessary. Check operation of spark plug, clean spark plug and replace if necessary.

A problem with the carburetor or the engine can also be the reason for erratic running behavior.

Condition	Cause	Remedy
No spark	Spark plug faulty	Install new spark plug
	Faulty insulation or short in short circuit wire	Check short circuit wire for short circuit to ground
	Break in ignition lead or insulation damaged	Check ignition lead, replace ignition module if necessary
	Ignition module faulty	Install new ignition module

4.6 Carburetor

Condition	Cause	Remedy
Carburetor floods; engine stalls	Inlet needle not sealing. Foreign matter between valve seat and cone or cone worn	Remove and clean or replace the inlet needle, clean the carburetor, replace inlet needle if necessary
	Inlet control lever sticking on spindle	Clean inlet control lever, replace if necessary
	Helical spring not located on nipple of inlet control lever	Remove the inlet control lever and refit it correctly
	Perforated disc on diaphragm is deformed and presses constantly against the inlet control lever	Fit a new metering diaphragm
Poor acceleration	Setting of low speed screw too lean	Check basic carburetor setting, correct if necessary
	High speed screw too rich	Check basic carburetor setting, correct if necessary
	Inlet needle sticking to valve seat	Remove inlet needle, clean and refit
	Diaphragm gasket leaking	Fit new diaphragm gasket
	Metering diaphragm damaged or shrunk	Fit new metering diaphragm
	Manifold damaged	Install new manifold

Condition	Cause	Remedy
Engine will not idle, idle speed too high	Throttle shutter opened too wide by idle speed screw (LA)	Reset idle speed screw (LA) correctly
	Oil seals/engine leaking	Seal or replace oil seals/engine
	Air valve contaminated – does not close	Clean air valve, replace if necessary
	Air valve stiff	Check air valve, replace if necessary
	Throttle rod stiff – throttle shutter does not close	Replace throttle rod and lever
Engine stalls at idle speed	Idle jet bores or ports blocked	Clean the carburetor
	Idle jet too rich or too lean	Set low speed screw (L) correctly
	Setting of idle speed (LA) incorrect – throttle shutter completely closed	Set idle speed screw (LA) correctly

Condition	Cause	Remedy
Engine speed drops quickly under load – low power	Air filter dirty	Clean the air filter
	Throttle shutter not opened fully	Check throttle rod
	Tank vent faulty	Replace tank vent
	Fuel pickup body dirty	Install new pickup body
	Fuel strainer dirty	Clean fuel strainer in carburetor, replace if necessary
	Leak in fuel line between tank and fuel pump	Install new fuel line
	Setting of high speed screw (H) too rich	Check basic carburetor setting, correct if necessary
	Main jet bores or ports blocked	Clean the carburetor
Pump diaphragm damaged or fatigued	Fit new pump diaphragm	
Engine running extremely rich, no power and very low maximum speed	Air valve does not open	Check lever on air valve and replace if necessary
Engine running too rich, low power and low maximum speed	Air valve does not open fully in full throttle position	Check lever on air valve and replace if necessary
Erratic idle – too lean	Air valve does not close properly	Check lever on air valve and replace if necessary

4.7 Engine

Always check and, if necessary, repair the following parts before looking for faults on the engine:

- Air filter
- Fuel system
- Carburetor
- Ignition system

Condition	Cause	Remedy
Engine does not start easily, stalls at idle speed, but operates normally at full throttle	Oil seals in engine damaged	Replace the oil seals
	Engine leaking or damaged (cracks)	Seal or replace the engine
Engine does not deliver full power or runs erratically	Piston rings worn or broken	Fit new piston rings
	Muffler / spark arresting screen carbonized	Clean the muffler (inlet and exhaust), replace spark arresting screen, replace muffler if necessary
	Air filter element dirty	Replace air filter element
	Fuel hose severely kinked or damaged	Fit new hose or position it free from kinks
	Tank vent faulty	Check tank vent and replace if necessary
	Air valve does not open	Check air valve and replace if necessary
Engine overheating	Insufficient cylinder cooling. Air inlets in fan housing blocked or cooling fins on cylinder very dirty	Thoroughly clean all cooling air openings and the cylinder fins

5. Cutting Attachment

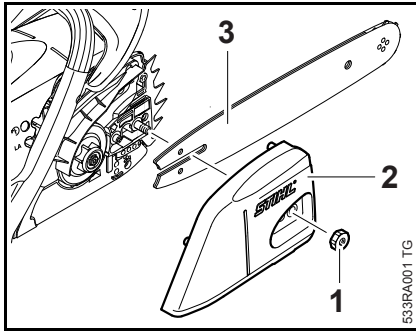

Wear gloves to protect your hands from injury.

- Unscrew the hex nut (1).
- Remove the chain sprocket cover (2).
- Remove the bar (3) and chain.
- Install in the reverse sequence.

Machines with quick chain tensioner

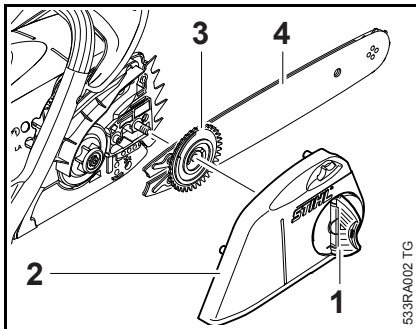

Wear gloves to protect your hands from injury.

- Open up the wing nut (1) and unscrew it counterclockwise.
- Remove the chain sprocket cover (2) and tensioning gear (3) with guide bar (4).
- Install in the reverse sequence.

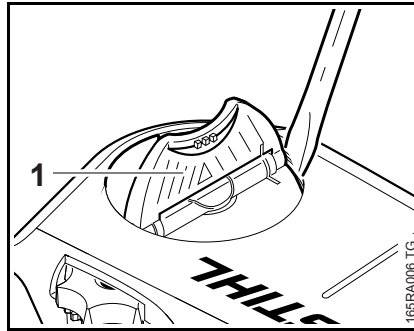

- Apply screwdriver to side (1) of wing nut and pry it out of its seat.
- Check the wing nut and replace if necessary.

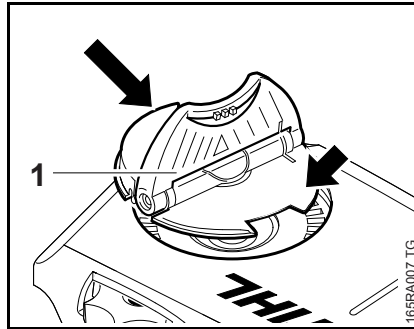

- Open up the wing nut.
- Push the wing nut (1), thin side first (arrow), into the opening and press it home until it snaps into position.

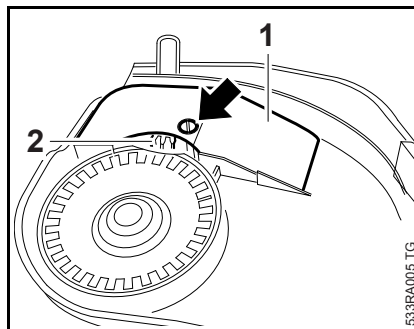

- Remove the screw (arrow).
- Remove the cover plate (1) and adjusting wheel (2).

When installing the adjusting wheel, check that its teeth face the cover plate.

- Reassemble in the reverse sequence.

5.1 Chain Catcher

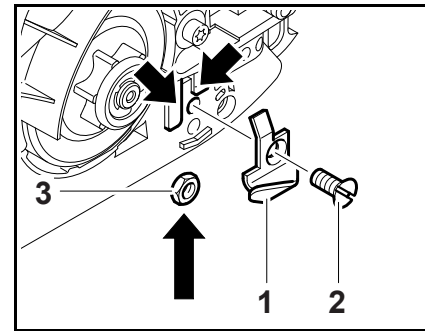

A replacement chain catcher can be fitted if the integral chain catcher on the chain sprocket cover is worn.

- Remove the chain sprocket cover, bar and chain, [15](#)
- File down the damaged chain catcher on the chain sprocket cover.





- Position the replacement chain catcher (1) in the guides (arrows).
- Push the countersunk screw (2) through the bore in the engine housing and fit the locknut (3) at the other side.
- Tighten down the countersunk screw firmly – the locknut butts against the engine housing and need not be held.
- Reassemble all other parts in the reverse sequence.
- Tightening torques, [15](#) 3.5

6. Clutch

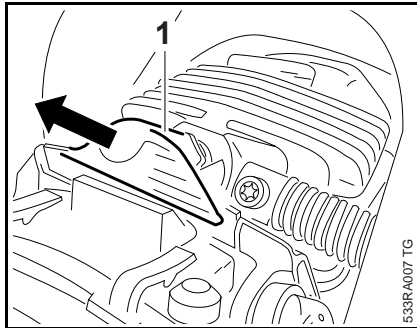
- Troubleshooting,  4.1
- Remove the chain sprocket cover, bar and chain,  5
- Remove the clutch drum,  6.1



- Remove the shroud,  8.4
- The spring may be preloaded on machines with ErgoStart. It is therefore necessary to remove the fan housing,  10.1 and  10.2

- Pull off the spark plug boot (1).

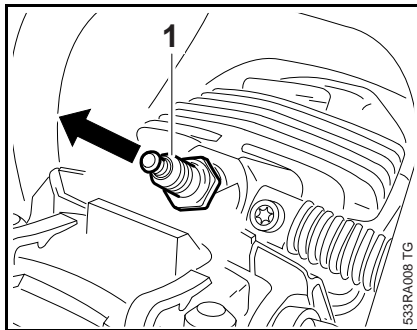

- Unscrew the spark plug (1).

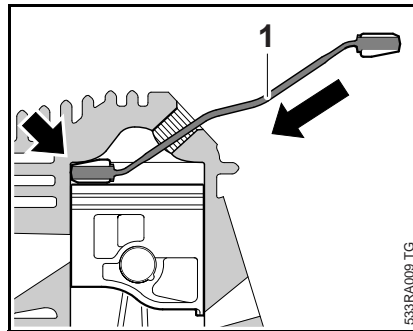

- Push the locking strip (1) 0000 893 5904 into the spark plug hole until it butts against the cylinder wall (arrow) as shown.

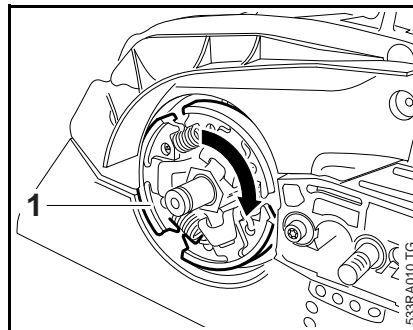

- Unscrew the clutch (1).

Note that the clutch has a left-hand thread.

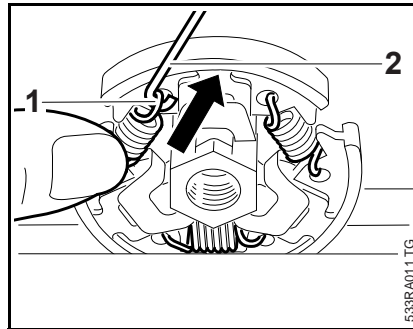

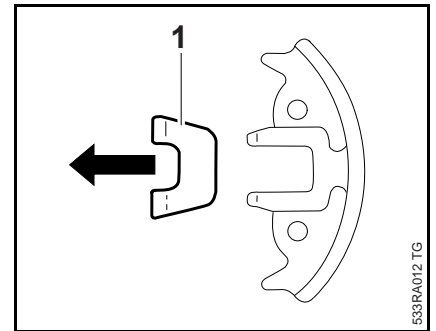

Disassembling

- Clamp the clutch in a vise.
- Use hook (2) 5910 890 2800 to remove the clutch springs (1).

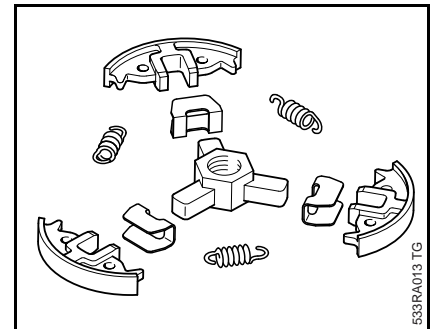

- Pull the clutch shoes off the carrier.
- Pull the retainers (1) off the clutch shoes.



- Clean all parts,  16
- Replace any damaged parts.

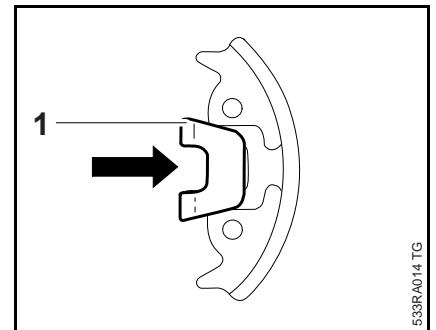

- Slip the retainers (1) onto the clutch shoes.

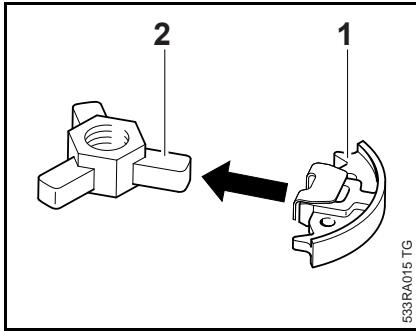

- Fit the clutch shoes (1) over the arms (2).

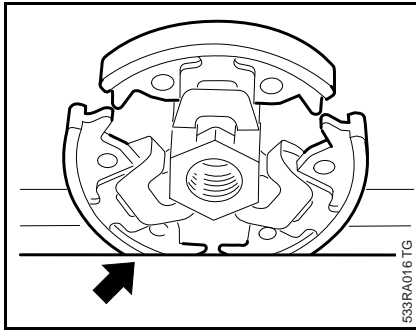

- Clamp the clutch in a vise (arrow).

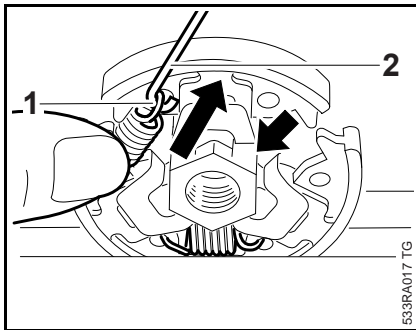

Attach the springs to the side with the raised hexagon (arrow).

- Attach one end of each spring (1) to the clutch shoes.
- Use the hook (2) 5910 890 2800 to attach the other ends of the springs and press them firmly into the clutch shoes – do not overstretch the springs.

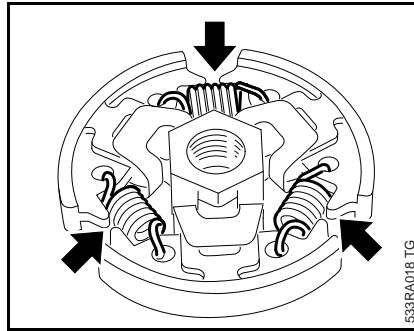

- Check the clutch – all springs (arrows) must be properly attached.

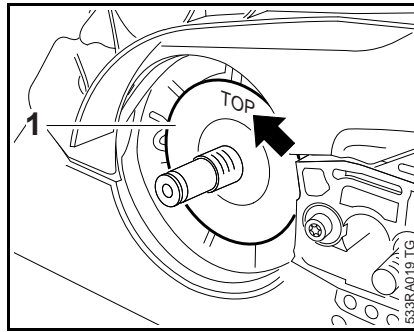

- Cover washer (1) must be in position.

It is correctly fitted when “TOP” (arrow) faces outwards.

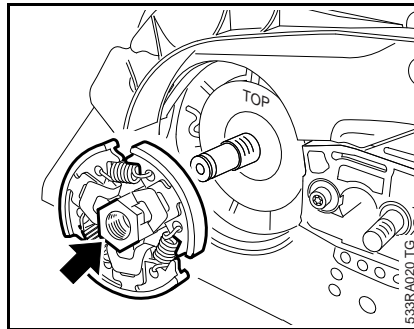

- Position the clutch on the crankshaft stub so that the raised hexagon (arrow) faces outwards.

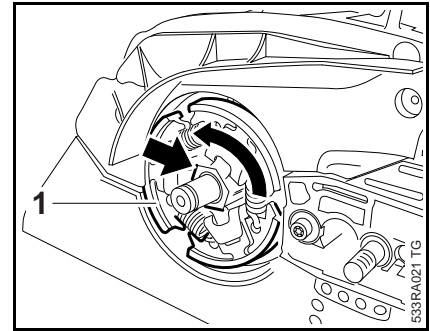

- Use the hexagon (arrow) to screw the clutch (1) onto the crankshaft stub. Check the position of the locking strip and then tighten down the clutch firmly – left-hand thread.

- Tightening torques, 3.5
- Remove the locking strip from the cylinder.
- Reassemble all other parts in the reverse sequence.

6.1 Clutch Drum

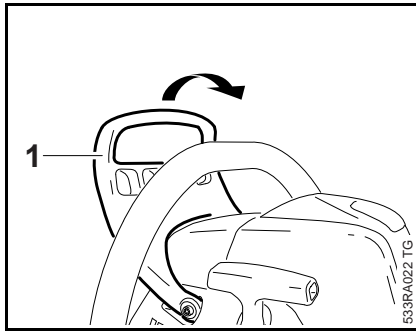

- On machines with ErgoStart, relieve spring tension, 10.4
- Remove the chain sprocket cover, bar and chain, 5
- Pull the hand guard (1) towards the front handle.

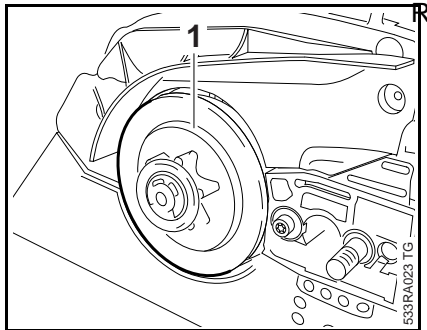

Remove and install the clutch drum (1), see instruction manual.

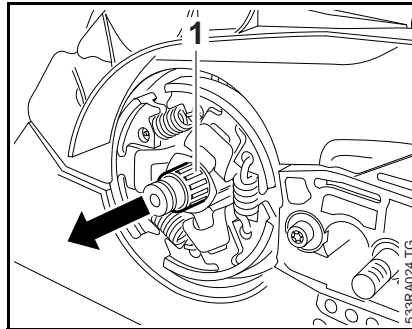

- Pull off the needle cage (1).
- Clean the needle cage and crankshaft stub, 16
- Lubricate the needle cage and crankshaft stub, 16

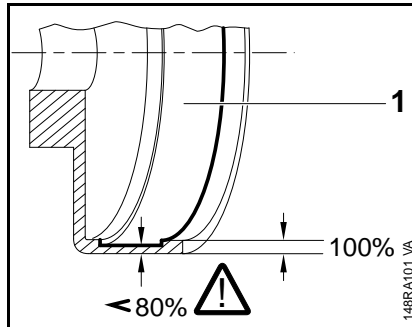

- Inspect the clutch drum (1) for signs of wear.

If there are signs of serious wear on the inside diameter of the clutch drum (1), check the remaining wall thickness. If it is less than about 80% of the original thickness, install a new clutch drum.

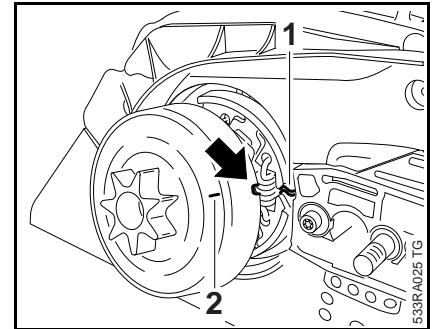

The notch (arrow) in the clutch drum must engage the worm's spring (1).

Use the mark (2) for alignment.

- Apply thin coating of oil to the outside of the clutch drum and the brake band.
- Reassemble all other parts in the reverse sequence.

7. Chain Brake

7.1 Checking Operation

The chain brake is one of the most important safety devices on the chainsaw. Its efficiency is measured in terms of the chain braking time, i.e. the time that elapses between activating the brake and the saw chain coming to a complete standstill.

Contamination (with chain oil, chips, fine particles of abrasion, etc.) and smoothing of the friction surfaces of the brake band and clutch drum impair the coefficient of friction. This, in turn, reduces the frictional forces and thus prolongs the braking time. A fatigued or stretched brake spring has the same negative effect.

- Start the engine
- With the chain brake activated (locked), open the throttle wide for a brief period (max. 3 seconds) – the chain must not rotate.
- With the chain brake released, open the throttle wide and activate the brake manually – the chain must come to an abrupt stop.

The braking time is in order if deceleration of the saw chain is imperceptible to the eye.

If the chain brake does not operate properly, refer to troubleshooting, [4.2](#).

7.2 Removing and Installing the Brake Band

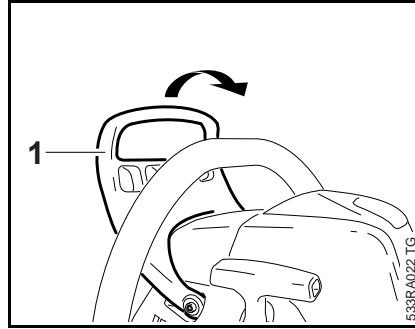

- Troubleshooting, [4.2](#)
- Remove the chain sprocket cover, bar and chain, [5](#)
- Disengage the chain brake by pulling the hand guard (1) towards the front handle – the brake band is loose.
- Remove the clutch drum, [6.1](#)
- Push the hand guard (1) towards the guide bar – the brake band is tensioned.

To reduce the risk of injury, do not activate the chain brake while the chain brake cover is open.

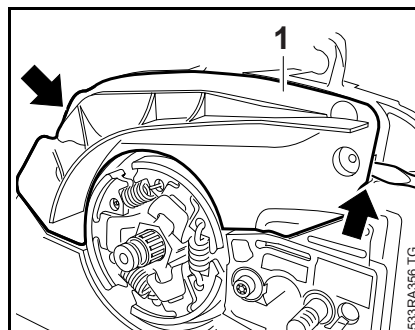

- Use a screwdriver to ease the cover (1) away at the points shown (arrows).
- Remove and inspect the cover (1), service or replace if necessary.

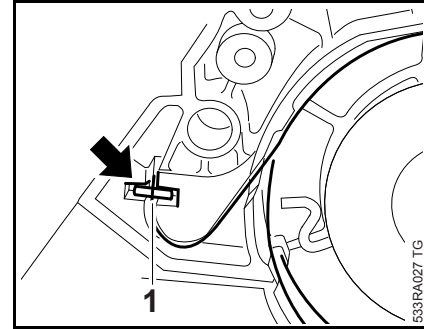

- Pry the brake band (1) out of its seat (arrow).

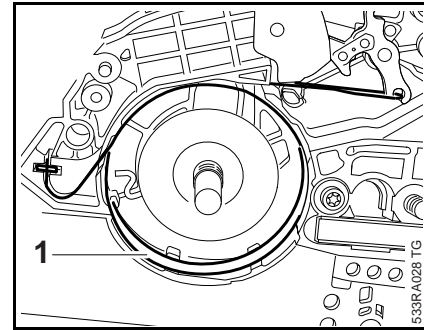

- Swing the brake band (1) outwards.

Do not over-stretch the brake band.

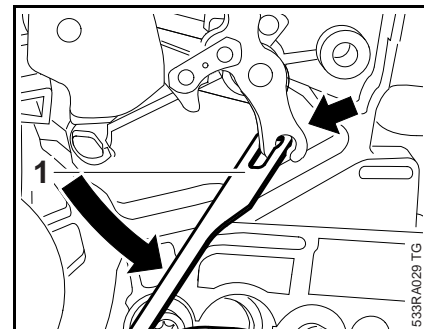

- Turn the brake band (1) slightly to one side and disconnect it from the brake lever (arrow).

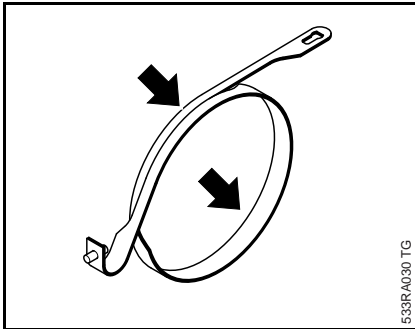

533RA030 TG

Install a new brake band if there are noticeable signs of wear (large areas on inside diameter and/or parts of outside diameter) and its remaining thickness is less than 0.6 mm.

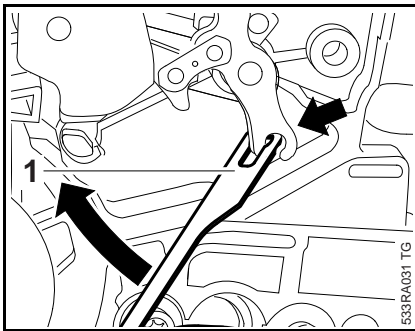

533RA031 TG

● Attach the brake band (1) to the brake lever (arrow) from the side and then turn it in the direction of its seat.

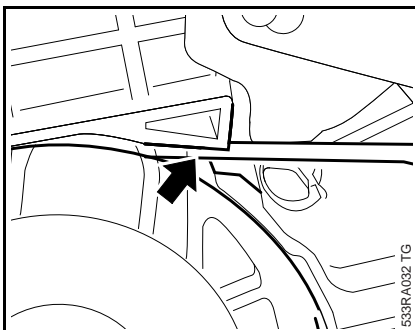

533RA032 TG

● Swing the brake band into the guide (arrow) first.

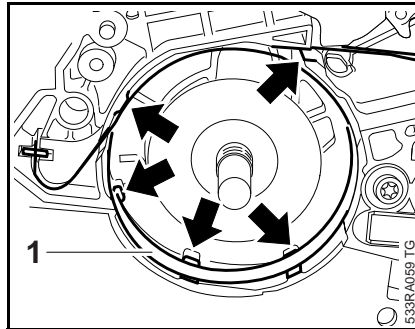

533RA069 TG

● Push the brake band (1) into the guides (arrows).

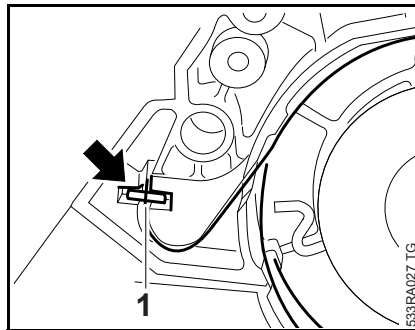

533RA027 TG

● Push the brake band (1) into its seat (arrow) as far as stop.

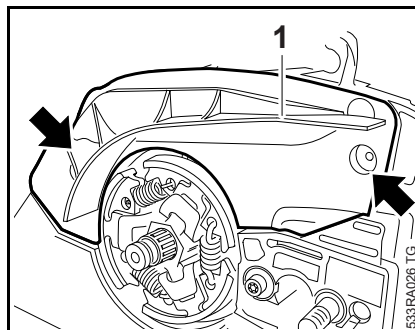

533RA026 TG

– Engage pegs on cover (1) in the holes (arrows) and push it fully home.

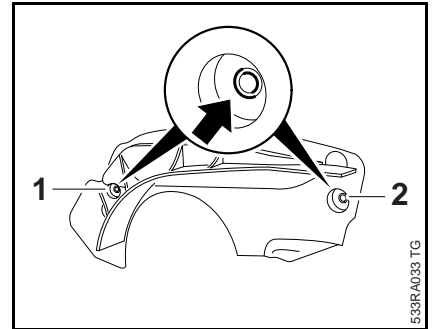

533RA033 TG

If the pegs have broken off, the cover can be serviced.

– Drill out the recesses exactly in the center (arrow):
a (1) = Ø 4.5 mm
b (2) = Ø 5.5 mm

– If a peg is stuck in the engine housing, remove it by pushing it inwards.

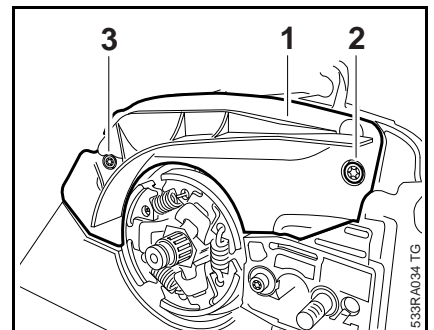

533RA034 TG

– Place the cover (1) in position.

– Fit D 5x16 screw (2) and P 4x16 screw (3) and tighten down firmly.

– Tightening torques, 3.5

– Install the clutch drum, 6.1

– Reassemble all other parts in the reverse sequence.

– Check operation.

7.3 Brake Lever

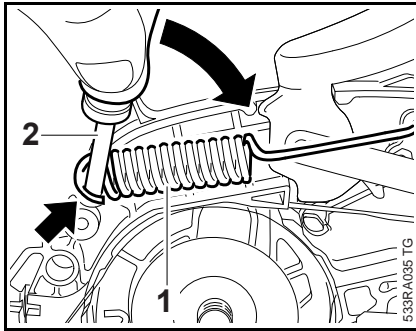

- Troubleshooting, 4.2
- Remove the brake band, 7.2
- Push the hand guard away from the front hand to relax the brake spring.
- Use the assembly tool (2) 1117 890 0900 to disconnect the brake spring (1) from the anchor pin (arrow) – the spring may pop out during this operation.
- Disconnect the brake spring from the brake lever.

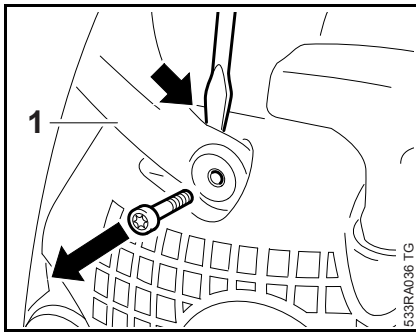

- Take out the screw.
- Pry the hand guard (1) off the fan housing (arrow).
- To ease assembly, remove the rewind starter, 10.2

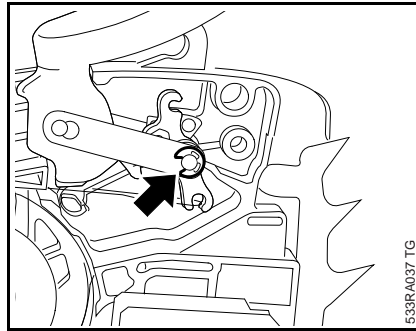

- Remove the E-clip (arrow).

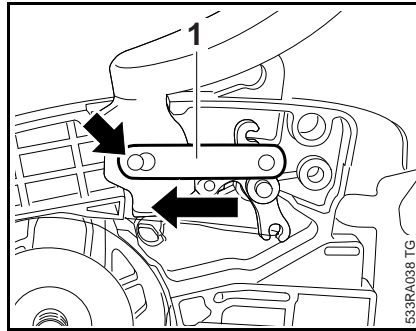

- Lift and turn the strap (1) a little, then push it to the left as far as the hole (arrow) and remove it.

- Remove the spacer sleeve from the brake lever.

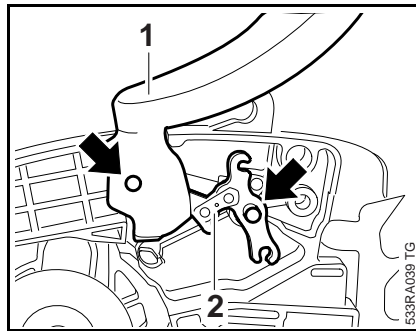

- Pull the hand guard (1) and brake lever (2) off the pivot pins (arrows) together.

- Remove the hand guard and brake lever.

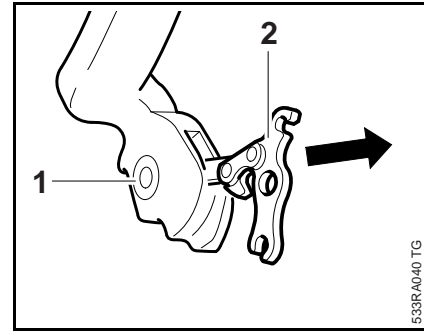

- Pull the brake lever (2) out of the hand guard (1).

- Inspect the brake lever and hand guard and replace if necessary.

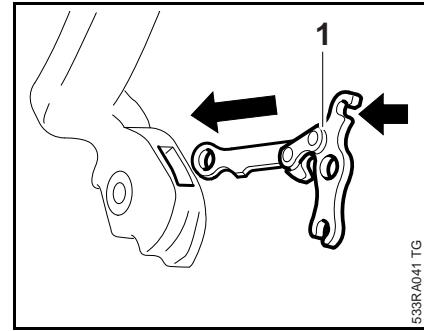

- Inspect the pivot pins and replace if necessary, 7.5

- Inspect the flat spring and replace if necessary., 7.4

- Clean all disassembled parts, 16

- Position the brake lever so that the hook (arrow) for the brake spring is at the top.

- Push the brake lever (1) into the hand guard recess and line up the holes.

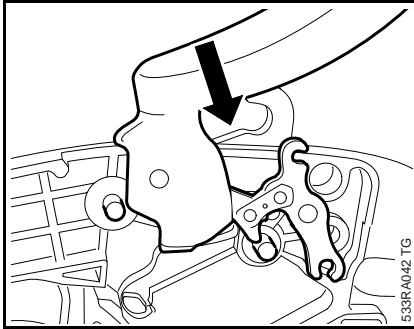

- Lubricate the pivot pins, 16
- Push the hand guard and brake lever over the machine until they butt against the pivot pins.

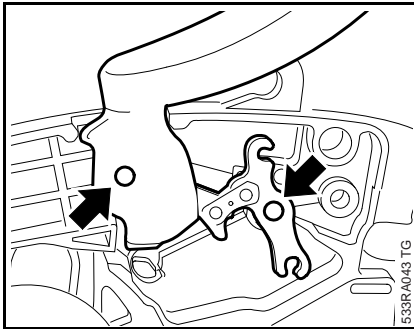

- Lift the bearing boss of the hand guard and the brake lever a little and position them on the pivot pins (arrows).

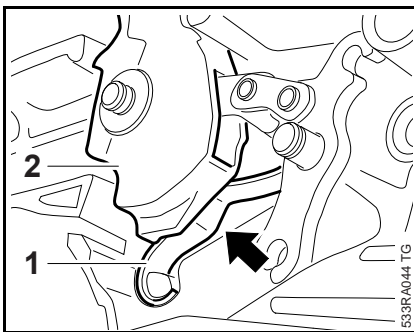

- Ease the cam (arrow) of the hand guard (2) past the flat spring (1).
- Push the hand guard and brake lever onto the pivot pins, moving the hand guard to and fro at the same time.

- Locate the hand guard at the starter side and fit the screw.

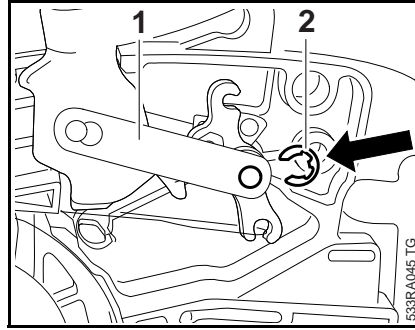

- Push on the spacer sleeve.
- Fit the strap (1).
- Fit the E-clip (2).

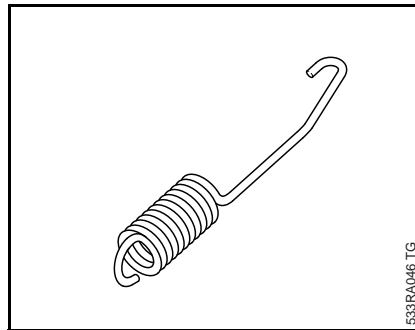

- The turns of brake spring must be tightly against one another in the relaxed condition. If this is not the case, replace the brake spring.

If the groove in the brake spring anchor pin is worn, install a new pin, 7.5

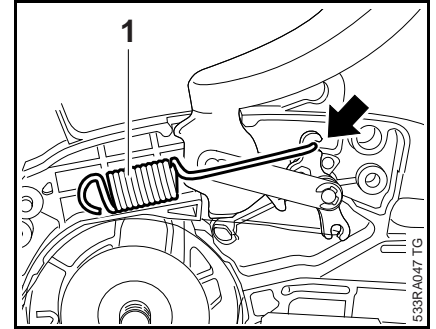

- Attach brake spring (1) to the brake lever (arrow).

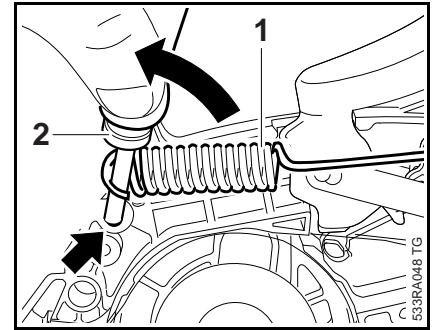

- Use assembly tool (2) 1117 890 0900 to attach the brake spring (1) to the anchor pin (arrow).

- Reassemble all other parts in the reverse sequence.
- Tightening torques, 3.5
- Lubricate the brake lever, 16

7.4 Flat Spring

The flat spring and hand guard cam hold the hand guard in position.

- Remove the brake lever, 7.3

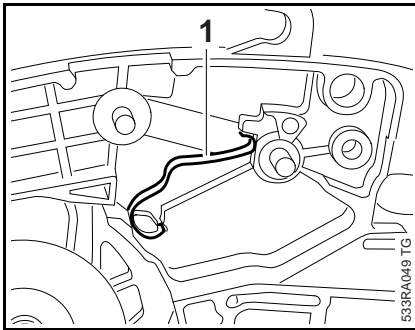

- Pull out the flat spring (1), check it and replace if necessary.

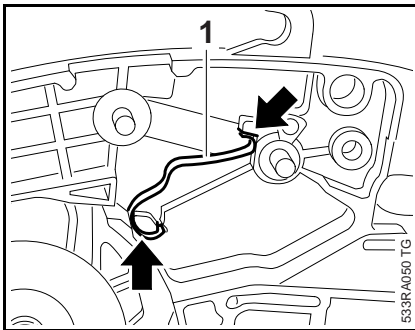

- Push the flat spring (1) into the guides (arrows).
- Lubricate the flat spring, 16
- Reassemble all other parts in the reverse sequence.
- Tightening torques, 3.5

7.5 Pins

The anchor pins secure the springs. Worn pins must be replaced.

All parts have been removed from the pins in the following illustrations for greater clarity.

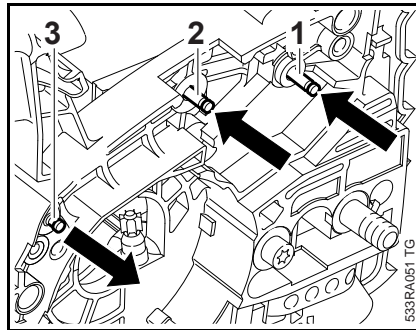

- Remove the engine, 8.5
- Use a suitable punch to drive out the pins (1+2) in the direction of the engine – use suitable support.
- Use a suitable punch to drive out the pin (3) in the direction of the clutch – use suitable support.

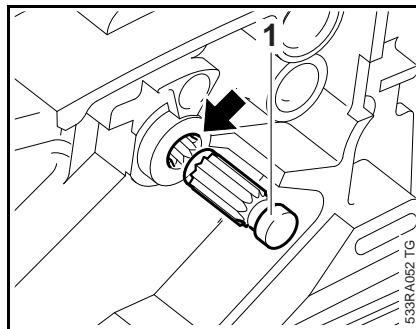

- Before installing the new pin (1), coat its knurled shank with Loctite, 16
- Position the new pin (1) in the bore (arrow) so that the knurling on the pin meshes with the existing knurling in the bore. Turn pin back and forth as necessary.

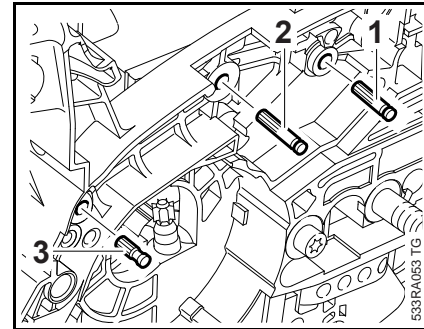

- Drive home pins (1+2+3) to specified lengths.

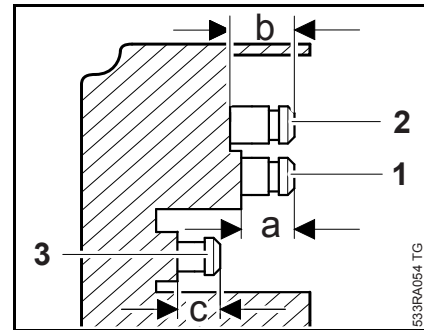

View from air filter side.

- Carefully tap home the pins squarely to obtain the following dimensions:
Pin (1) a = 8.9 mm
Pin (2) b = 12.1 mm
Pin (3) c = 4.0 mm
- Reassemble all other parts in the reverse sequence.
- Tightening torques, 3.5
- Lubricate the brake lever and flat spring, 16

7.6 Chain Tensioner

For machines with quick chain tensioner see [16](#) 5

- Remove the chain sprocket cover, bar and chain, [16](#) 5
- Troubleshooting, [16](#) 4.2

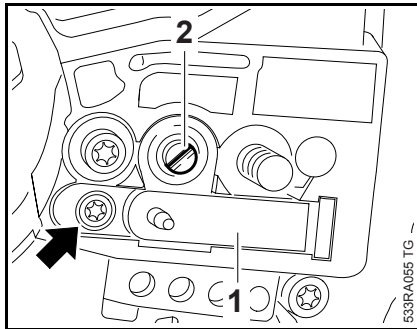

- Turn the spur gear (2) clockwise until the tensioner slide (1) butts against the right-hand end and the screw (arrow) is visible.

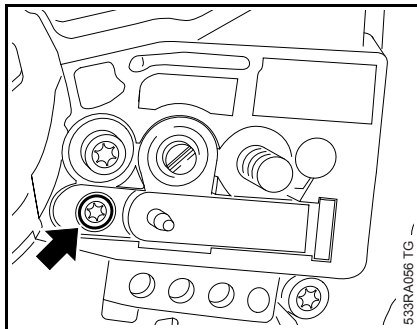

- Remove the screw (arrow).

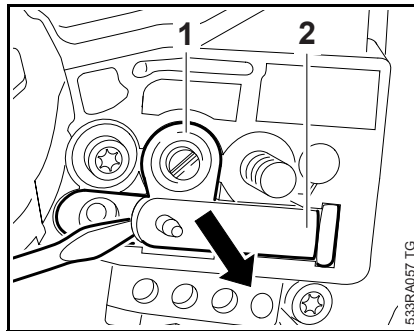

- Remove the spur gear (1) and tensioner slide (2).

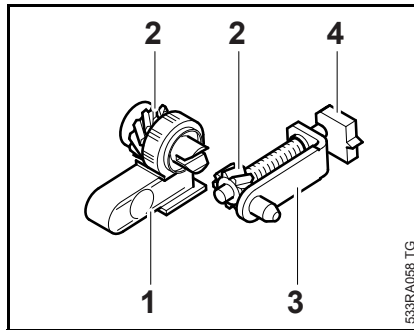

- Inspect the cover (1), spur gear assembly (2), tensioner slide (3) and thrust pad (4) and replace if necessary.

- Clean all disassembled parts, [16](#)
- Lubricate the chain tensioner with STIHL multipurpose grease, [16](#)
- Install in the reverse sequence.

7.7 Bar Mounting Studs

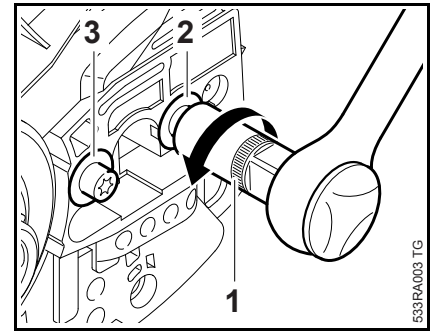

- Remove the chain sprocket cover, bar and chain, [16](#) 5

- Push stud puller 5910 893 0501 (1) over the collar stud (2) as far as it will go. Unscrew the stud.

- Unscrew collar stud (3).

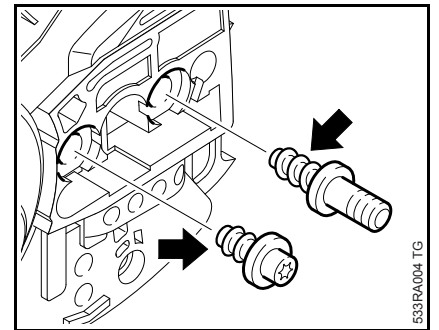

- Before installing, coat threads (arrows) of collar studs with Loctite, [16](#)

- Fit the collar studs and tighten them down firmly.
- Tightening torques, [16](#) 3.5
- Reassemble all other parts in the reverse sequence.

8. Engine

8.1 Muffler / Spark Arresting Screen

Always check and, if necessary, repair the fuel system, carburetor, air filter and ignition system before looking for faults on the engine.

– Troubleshooting,  4

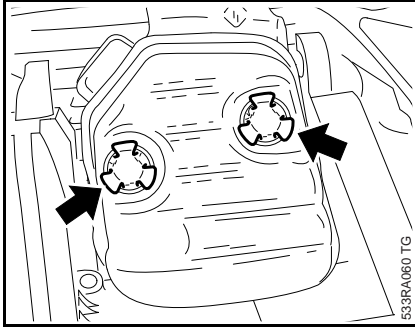

- Pry the plugs out of the muffer by means of the tabs (arrows).

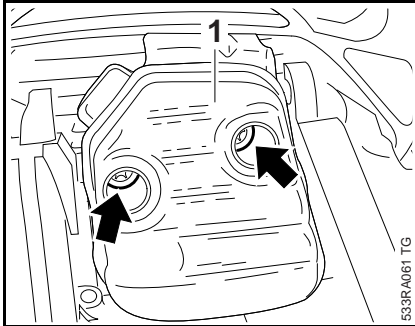

- Take out the screws (arrows).

– Remove the muffer (1), check and replace if necessary.

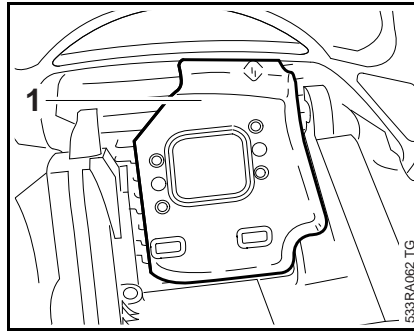

- Remove the heat shield (1).

Spark arresting screen

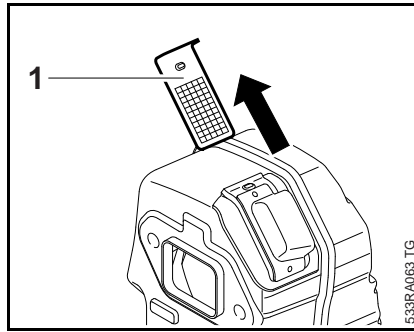

- Use suitable pliers to pull out the spark arresting screen (1) (if fitted).

– Clean the spark arresting screen (1) and replace if necessary.

– Install in the reverse sequence.

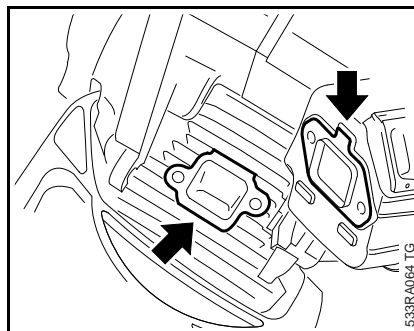

- Inspect and clean the sealing faces (arrows),  16

– Position machine vertically.

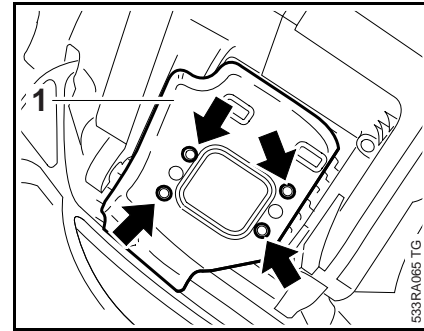

- Place the heat shield (1) in position and use the recesses (arrows) to line it up on the sealing face of the exhaust port.

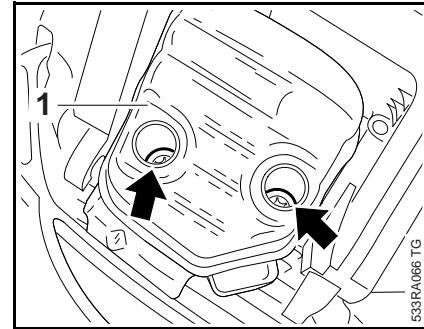

– Care place the muffer (1) in position.

- Fit the screws (arrows) and check correct position of heat shield again.

– Tighten down the screws (arrows) firmly.

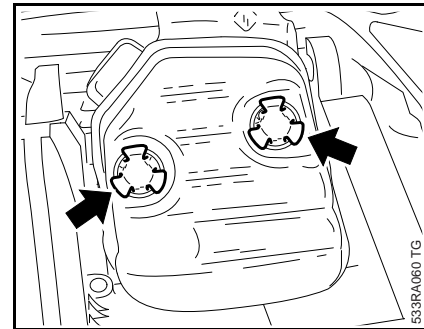

- Push home the plugs (arrows).

– Tightening torques,  3.5

8.2 Leakage Test

Defective oil seals and gaskets or cracks in castings are the usual causes of leaks. Such faults allow supplementary air to enter the engine and upset the fuel-air mixture.

This makes adjustment of the prescribed idle speed difficult, if not impossible.



Moreover, the transition from idle speed to part or full throttle is not smooth.

Always perform the vacuum test first.

The engine can be checked thoroughly for leaks with the pump 0000 850 1300.

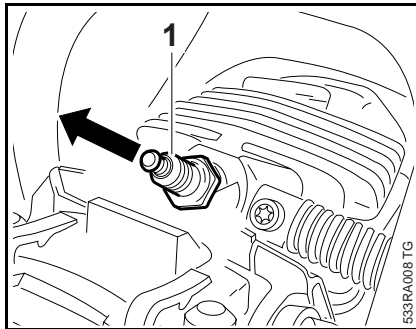
8.2.1 Preparations



- Remove the shroud,  8.4
- Unscrew the spark plug (1).
- Set the piston to top dead center. This can be checked through the inlet port.
- Fit spark plug (1) and tighten it down firmly.
- Tightening torques,  3.5

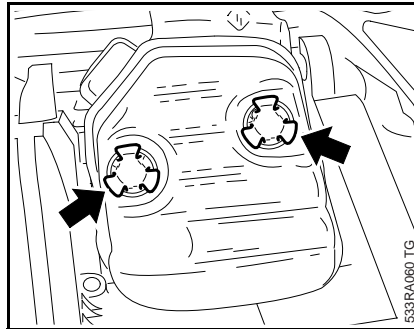

- Pry the plugs (arrows) out of the muffler.
- Take out the screws.
- Remove the muffler.

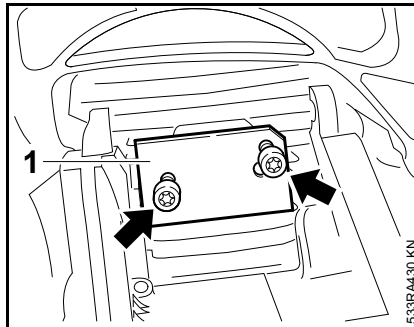

- Fit the flange (1) 1123 855 4200.
- Insert the screws (arrows).

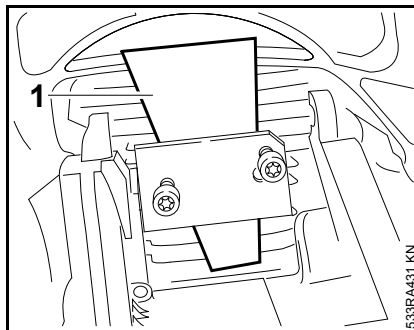

- Fit the sealing plate (1) 0000 855 8106 between the cylinder exhaust port and flange and tighten down the screws moderately.

The sealing plate must completely fill the space between the two screws.

- Remove the carburetor,  14.3

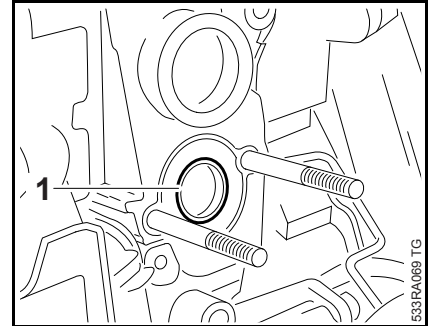

- Check that the sleeve (1) is in place.

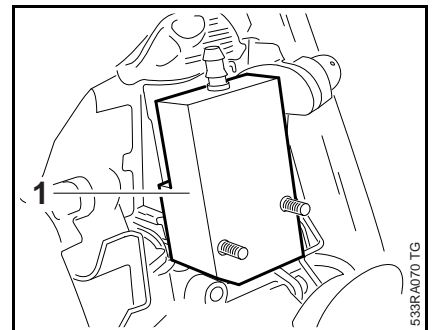

- Fit the test flange 1139 893 2500 (1).

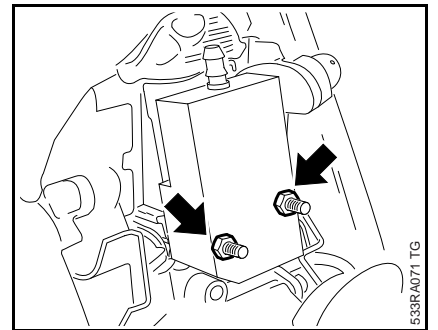

- Fit the nuts (arrows) and tighten them down firmly.

8.2.2 Vacuum Test

Oil seals tend to fail when subjected to a vacuum, i.e. the sealing lip lifts away from the crankshaft during the piston's induction stroke because there is no internal counterpressure.

A test can be carried out with pump 0000 850 1300 to detect this kind of fault.

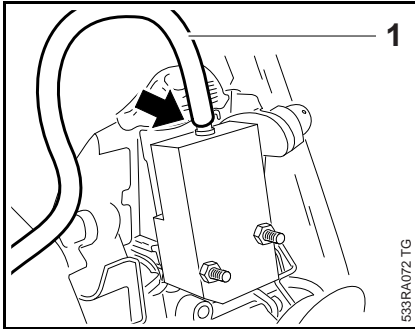

- Connect suction hose (1) of pump 0000 850 1300 to nipple (arrow).

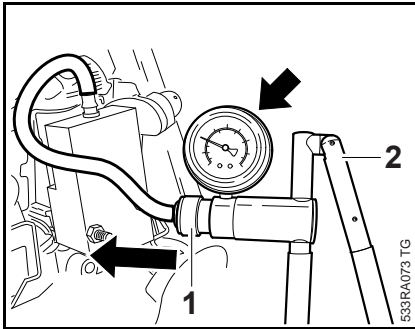

- Push ring (1) to the left.
- Operate the lever (2) until the pressure gauge (arrow) indicates a vacuum of 0.5 bar.

If the vacuum reading remains constant, or rises to no more than 0.3 bar within 20 seconds, it can be assumed that the oil seals are in good condition. However, if the pressure continues to rise (reduced vacuum in the engine), the oil seals must be replaced, [8.3](#)

- After finishing the test, push the ring to the right to vent the pump.
- Continue with pressure test, [8.2.3](#)

8.2.3 Pressure Test

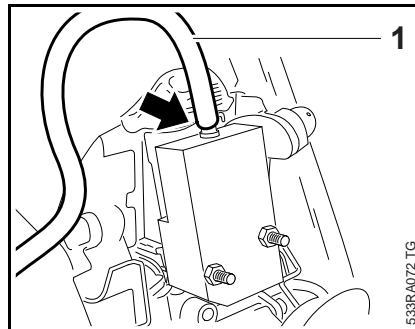

Carry out the same preparations as for the vacuum test, [8.2.2](#)

- Always carry out the vacuum test before the pressure test, [8.2.2](#)
- Connect pressure hose (1) of pump 0000 850 1300 to nipple (arrow).

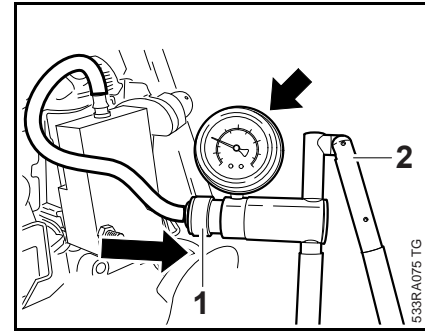

- Push the ring (1) to the right.
- Operate the lever (2) until the pressure gauge (arrow) indicates a pressure of 0.5 bar. If this pressure remains constant for at least 20 seconds, the engine is airtight.

- If the pressure drops, the leak must be located and the faulty part replaced.

To find the leak, coat the suspect area with oil and pressurize the engine. Bubbles will appear if a leak exists.

- After finishing the test, push the ring to the left to vent the pump – disconnect the hose.
- Remove the test flange.
- Install the carburetor, [14.3](#)
- Loosen the muffler and remove the sealing plate.
- Tighten down the muffler firmly.
- Reassemble all other parts in the reverse sequence.
- Tightening torques, [3.5](#)

8.3 Oil Seals

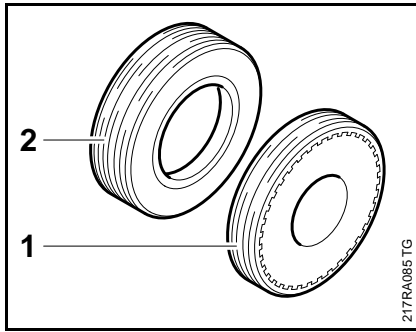

Use oil seal (1) 9638 003 1581 if the engine is not opened.
Install oil seal (2) 9639 003 1585 if the engine has been opened up.

It is not necessary to disassemble the complete engine to replace the oil seals.

Ignition side

- Remove the fan housing, 10.1 and 10.2
- Remove the flywheel, 9.5

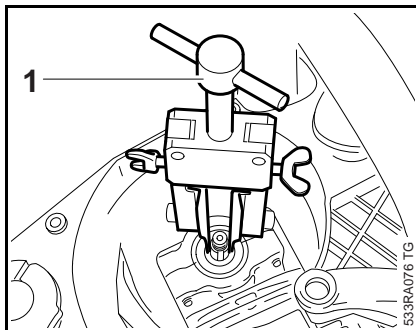

- Free off the oil seal in its seat by tapping it with a suitable tube or a punch.
- Apply puller (1) 5910 890 4400 with No. 3.1 jaws 0000 893 3706.

- Clamp the puller arms.
- Pull out the oil seal.

Take care not to damage the crankshaft stub.

- Cleaning the sealing face, 16
- Lubricate sealing lips of new oil seal with grease, 16

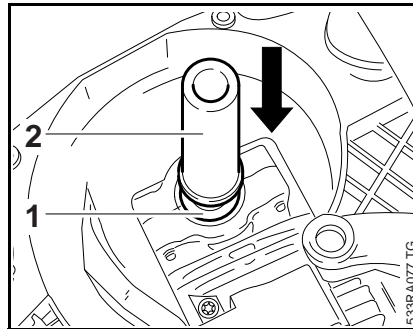

- Apply thin coating of sealant, 16, to the outside diameter of the oil seal.
- Slip the oil seal, closed side facing the engine, over the crankshaft stub.
- Use press sleeve (2) 1123 893 2400 to install the oil seal (1).

The seating face must be flat and free from burrs.

- Wait about one minute, then rotate the crankshaft several times.
- Degrease the crankshaft taper, 16
- Reassemble all other parts in the reverse sequence.

Clutch side

- Remove the chain sprocket cover, bar and chain, 5
- Remove the clutch, 6
- Remove the oil pump, 13.3

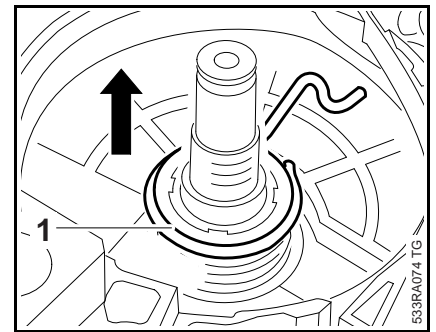

- Remove and inspect the worm (1), and replace if necessary.

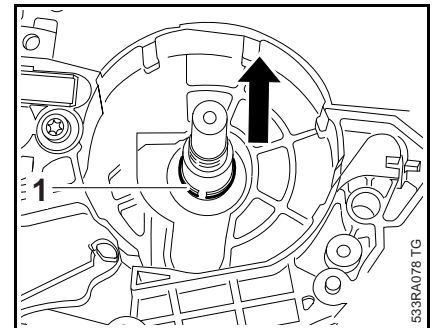

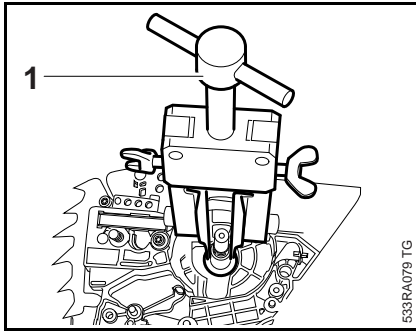

- Remove the retaining ring (1).



- Free off the oil seal in its seat by tapping it with a suitable tube or a punch.
- Apply puller (1) 5910 890 4400 with No. 3.1 jaws 0000 893 3706.
- Clamp the puller arms.
- Pull out the oil seal.

Take care not to damage the crankshaft stub.

- Cleaning the sealing face,  16
- Lubricate sealing lips of new oil seal with grease,  16

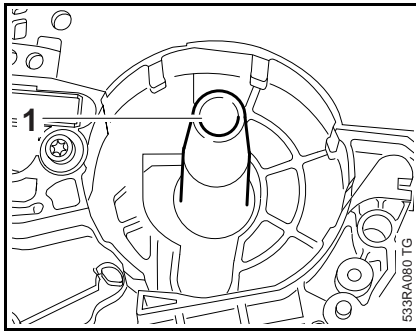

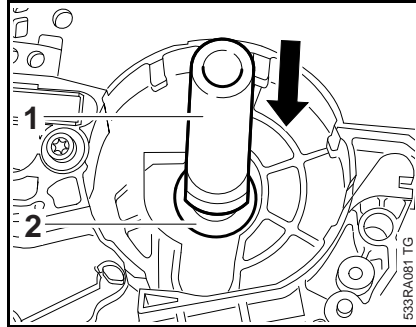

- Fit the installing sleeve (1) 1118 893 4602.
- Apply thin coating of sealant,  16, to the outside diameter of the oil seal.

- Slip the oil seal, closed side facing the engine, over the installing sleeve.
- Remove the installing sleeve (1).

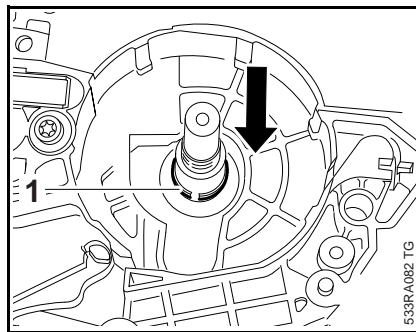

- Use press sleeve (1) 1123 893 2400 to install the oil seal (2).



- Wait about one minute, then rotate the crankshaft several times.
- Fit the retaining ring (1).
- Install the oil pump,  13.3
- Lubricate the worm with grease,  16

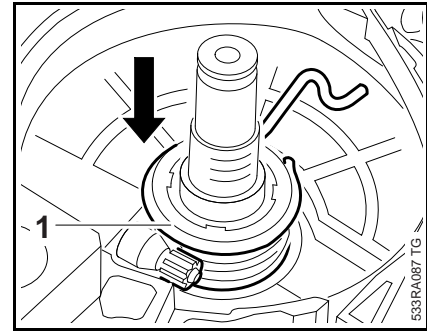

- Push the worm (1) onto the crankshaft stub as far as stop – it must engage the oil pump pinion.
- Reassemble all other parts in the reverse sequence.

8.4 Removing and Installing the Shroud

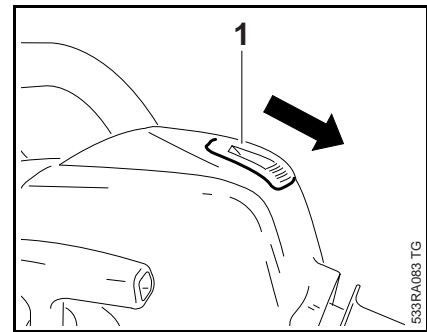

- Push slide lock (1) in direction of rear handle.

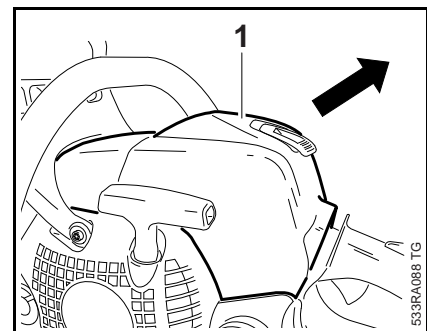

- Lift the shroud (1) a little and pull it off in the direction of the rear handle.

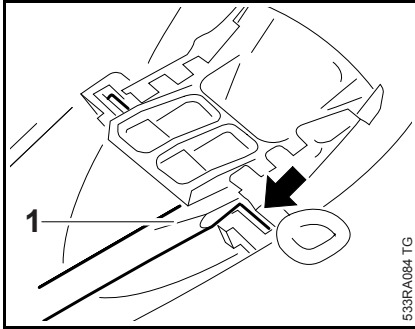

- Apply screwdriver above the spindle (arrow) and push it into the slide (1).

- Remove the slide (1).
- Inspect the slide and spindle and replace if necessary.

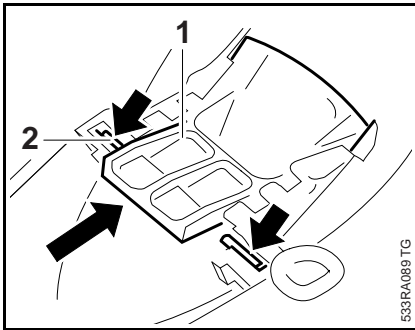

- Push the slide (1) into the guides (arrows) until it snaps into position in the spindle (2).

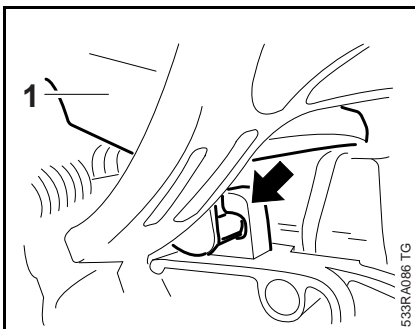

- Push the bearing lugs of shroud (1) into the guides (arrows) until they snap into position.

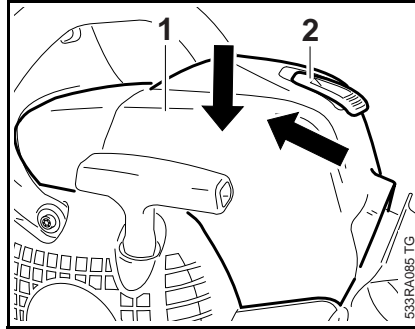

- Push the shroud (1) down as far as stop and secure in position with the slide lock (2).

8.5 Removing and Installing the Engine

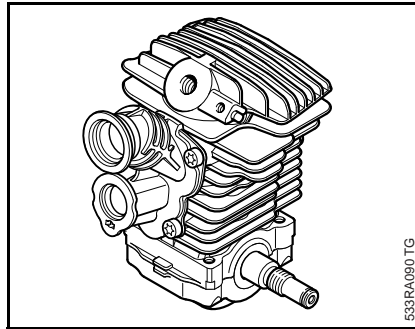

The complete engine has to be removed before removing either the piston or cylinder.

- Remove the shroud, [8.4](#)
- Remove the chain sprocket cover, bar and chain, [5](#)
- Remove the muffler, [8.1](#)
- Remove the clutch, [6](#)
- Remove the ignition module, [9.1](#)
- Remove the wiring harness, [9.6.2](#)
- Remove the flywheel, [9.5](#)
- Remove the handle frame, [11.4](#)
- Remove the throttle rod, [14.6](#)
- If necessary, also remove the carburetor carrier, [14.7.1](#)

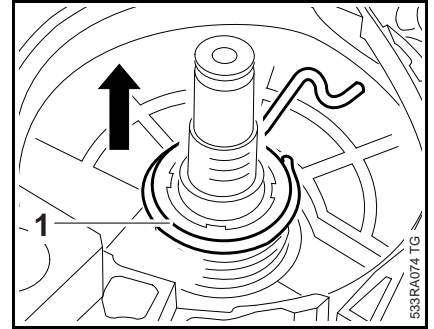

- Remove the worm (1).

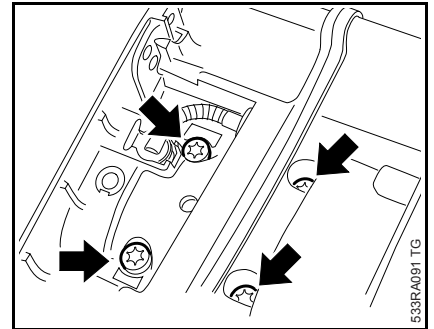

- Remove the cylinder mounting screws (arrows) from the underside of the engine housing – engine pan is also loose.

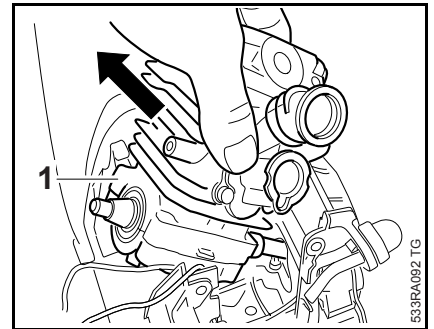

- Take the engine (1) out of the engine housing.

After loosening the engine pan, always clean the sealing faces and apply fresh sealant, [16](#)

The carburetor carrier can be also be removed after the engine has been removed.

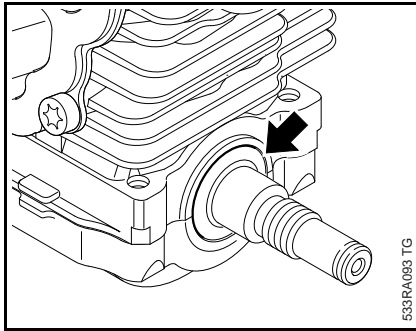

533RA083 TG

- Clean the sealing faces on the cylinder, engine pan and oil seals, remove gasket residue if necessary, [16](#)
- Apply fresh sealant to sealing faces, [16](#)
- Install new oil seals, [8.6](#)
- Make sure the oil seals are properly seated
 - they must be installed flush (arrow).

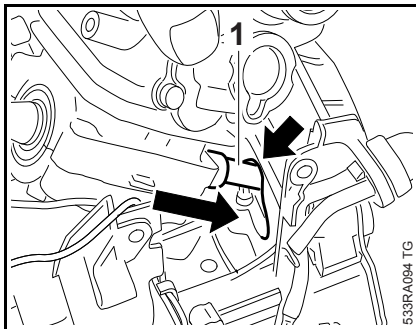

533RA084 TG

- Pass the clutch end of the crankshaft (1) through the opening (arrow) in the engine housing.
- Carefully place the engine in the engine housing
 - support engine pan from below with one hand.

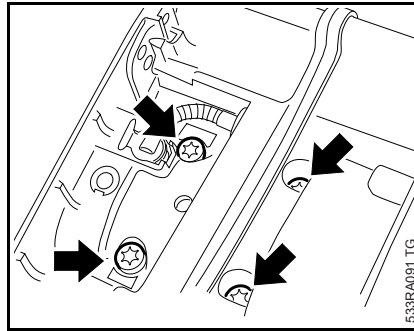

533RA091 TG

- Position the engine in the engine housing and hold it there
 - the holes in the engine housing, engine pan and cylinder must line up.
- Fit and tighten down the cylinder mounting screws (arrows).
- Install the worm, [8.3](#)
- Reassemble all other parts in the reverse sequence.
- Tightening torques, [3.5](#)
- Carry out leakage test, [8.2](#)

8.6 Crankshaft

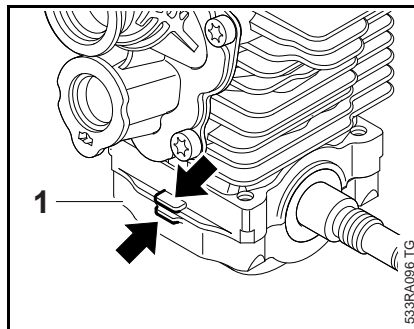

533RA086 TG

- Remove the engine, [8.5](#)
- Pry the engine pan (1) away from the engine at the lugs (arrows).
- Remove the engine pan.

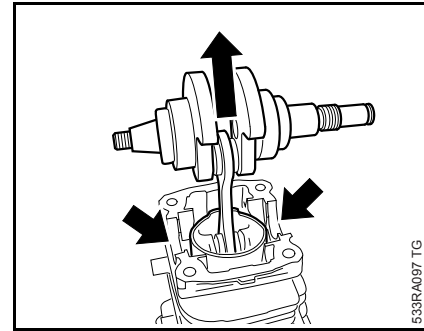

533RA087 TG

- Lift the crankshaft out of the bearing seats (arrows).
- Carefully pull the crankshaft and piston out of the cylinder.
- Inspect the crankshaft and ball bearings and replace if necessary, [8.7](#)
- Inspect piston and piston rings and replace if necessary, [8.8](#), [8.8.1](#)

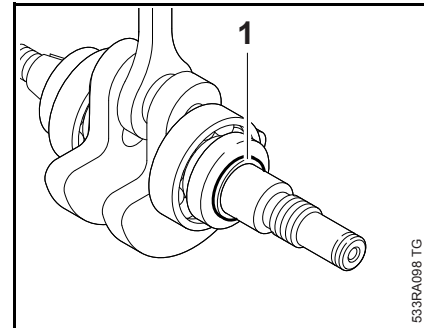

533RA088 TG

- Remove the retaining ring (1).

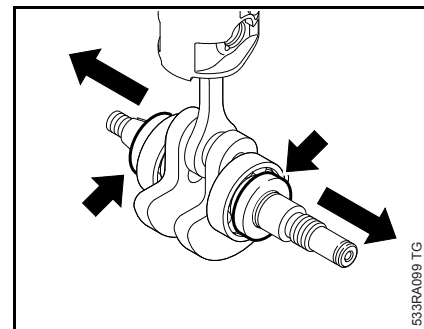

533RA089 TG

- Pull the oil seals (arrows) off the crankshaft stub.

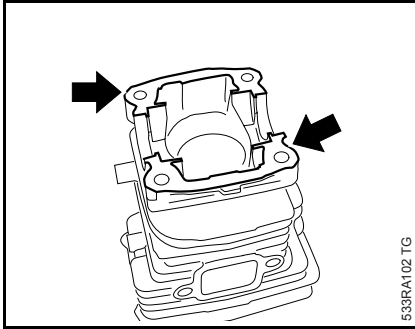

533RA102 TG

- Inspect the cylinder and clean the sealing faces (arrows), remove gasket residue if necessary, 16

The sealing faces must be clean and show no signs of damage. Parts with damaged sealing faces must be replaced.

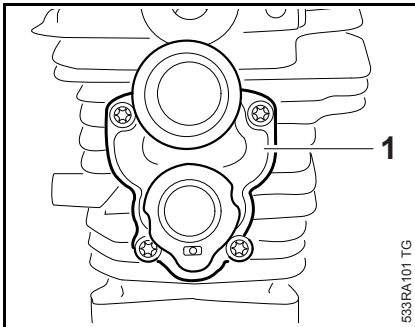

533RA101 TG

- Check the intake manifold (1) and replace if necessary, 14.7

If a new cylinder is installed, transfer the intake manifold (if it is still serviceable) from the old cylinder.

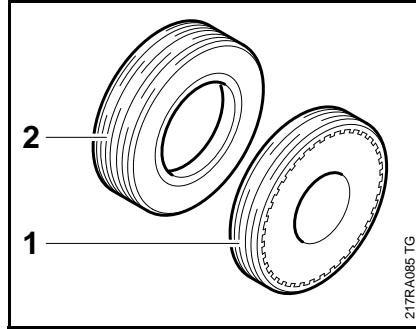

217RA085 TG

- Use oil seal (1) 9638 003 1581 if the engine is not opened. Install oil seal (2) 9639 003 1585 if the engine has been opened up.

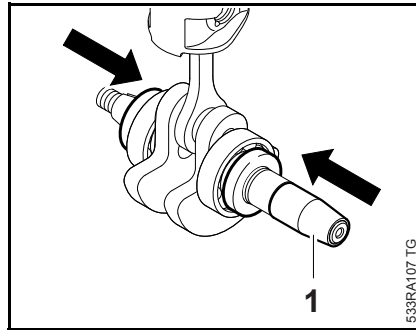

533RA107 TG

- Push the installing sleeve (1) 1118 893 4602 onto the crankshaft.
- Push the new oil seals, open side facing the crankshaft, onto the crankshaft stubs.

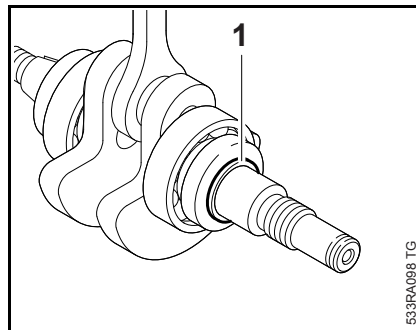

533RA098 TG

- Fit the retaining ring (1).

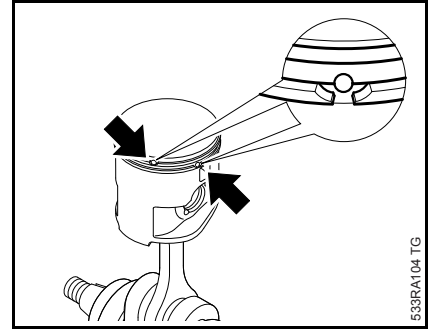

533RA104 TG

- Lubricate the piston, piston rings and cylinder wall with oil.
- Position the piston rings so that the radii at the ring gap meet at the fixing pin in the piston groove (arrows) – there is otherwise a risk of ring breakage.

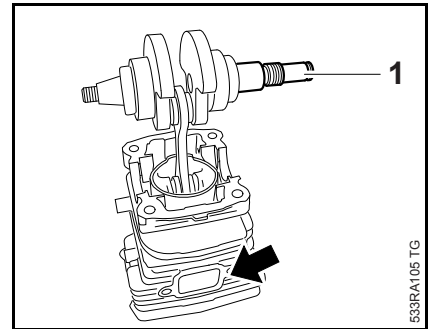

533RA105 TG

- Align the piston and crankshaft before installing in the cylinder.

Viewed from the exhaust port, the long crankshaft stub (1) must be on the right.

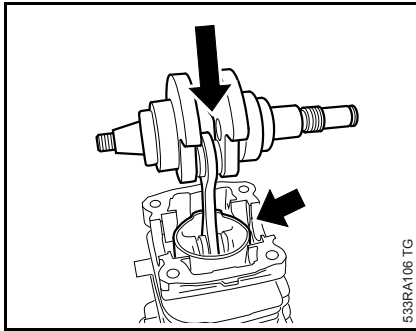

The pistons rings are compressed by the inner taper of the cylinder.

- Carefully push the piston with crankshaft into the cylinder (arrow).

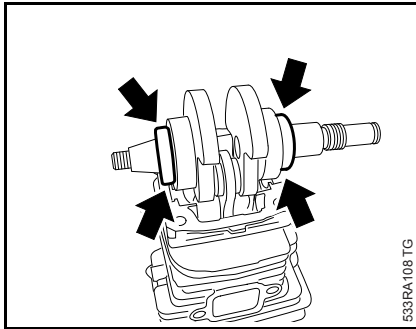

- Apply thin coating of sealant to the outside diameter (arrows) of the oil seals, 16

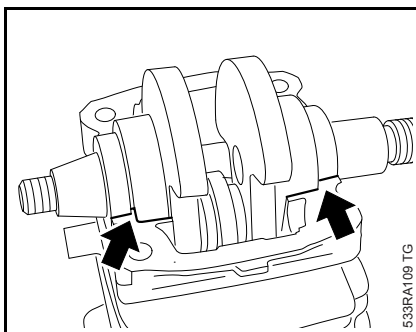

- Position the crankshaft with bearings and oil seals in the bearing seats in the cylinder, making sure the oil seals are properly seated (arrows) in the housing.

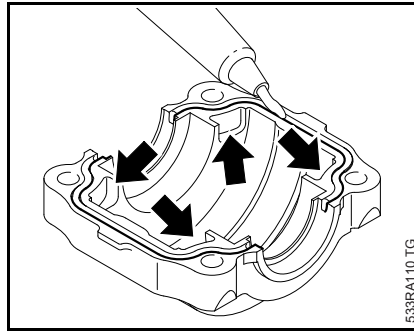

- Inspect and clean the mating face on the engine pan, remove gasket residue if necessary, 16

The mating faces must be perfectly clean and not be damaged in any way. Replace parts with damaged mating faces.

- Apply sealant along the groove, 16

Sealant must not get into the recesses (arrows) – the transfer ports must not be obstructed.

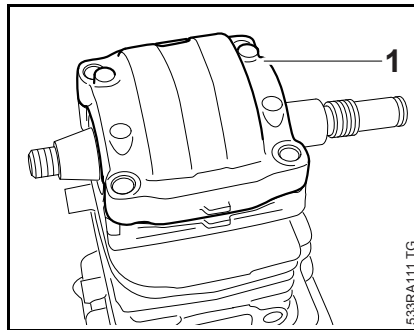

- Place the engine pan (1) on the cylinder.

Apply slight pressure to the engine pan so that the sealant is evenly distributed .

Take care not to damage the crankshaft stubs.

- Clean the crankshaft stub, 16
- Install the engine, 8.5
- Reassemble all other parts in the reverse sequence.

8.7 Ball Bearings/Crankshaft

- Remove the engine, 8.5
- Remove the crankshaft and oil seals, 8.6
- Remove the piston, 8.8

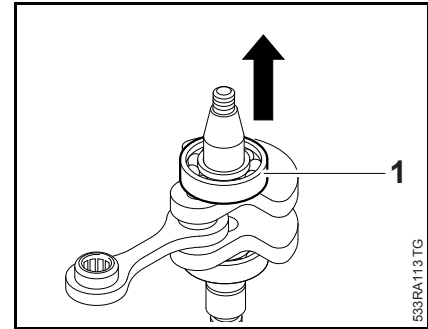

- Pull the ball bearing (1) off the ignition end of the crankshaft.

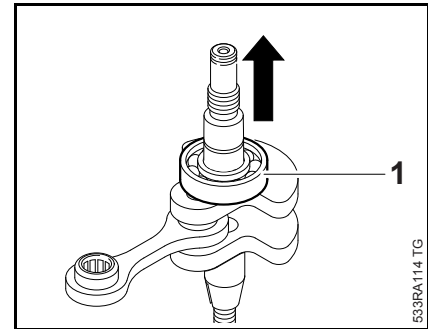

- Pull the ball bearing (1) off the clutch end of the crankshaft.

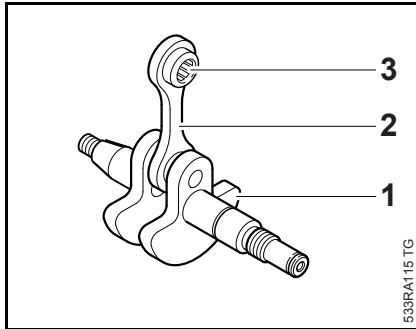

- The crankshaft (1), connecting rod (2) and needle bearing (3) are an inseparable unit. This means the crankshaft must always be replaced as a complete unit.

When fitting a replacement crankshaft, always install new ball bearings and oil seals.

- Clean the crankshaft before installing, [16](#)

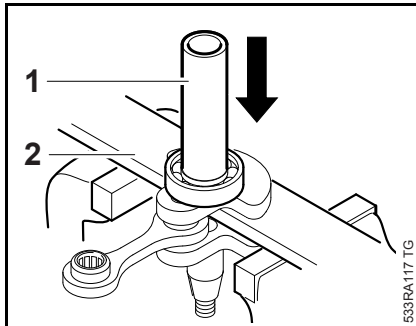

Use a firm support (2) to protect the crankshaft.

- Apply a suitable sleeve (1) to the inner race to press home the ball bearing at the clutch side as far as stop.

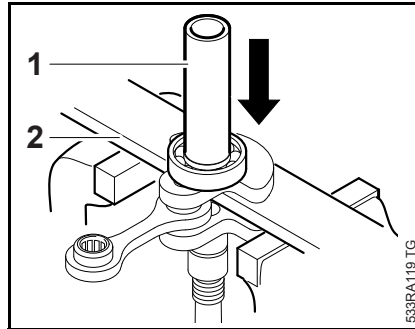

Use a firm support (2) to protect the crankshaft.

- Apply a suitable sleeve (1) to the inner race to press home the ball bearing at the ignition side as far as stop.

- Lubricate the needle bearing with oil.
- Install the piston, [8.8](#)
- Install the crankshaft and oil seals, [8.6](#)
- Install the engine, [8.5](#)

8.8 Piston

- Remove the engine, [8.5](#)
- Remove the crankshaft, [8.6](#)

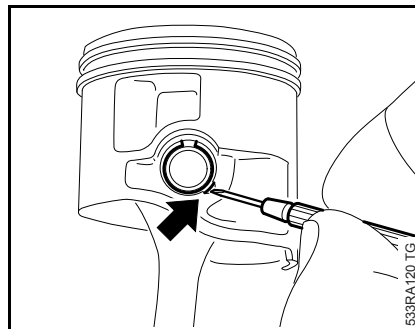

- Use a suitable tool to ease the hookless snap rings out of the grooves in the piston bosses (arrow).

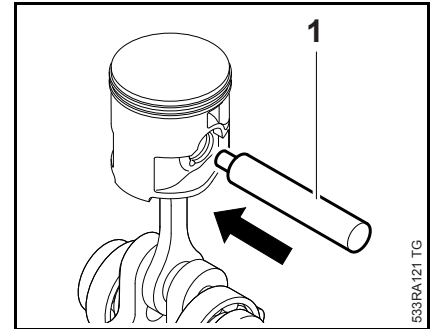

- Position the small diameter of assembly drift (1) 1110 893 4700 against the piston pin.

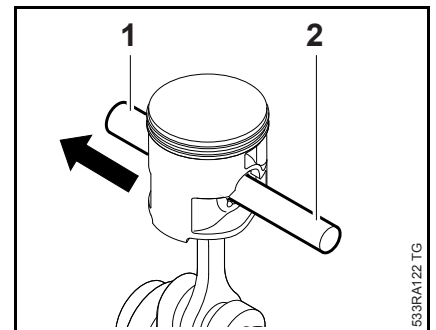

- Use the assembly drift (2) 1110 893 4700 to push the piston pin (1) out of the piston.

If the piston pin is stuck, release it by tapping the end of the drift with a hammer. Hold the piston steady during this process to ensure that no jolts are transmitted to the connecting rod..

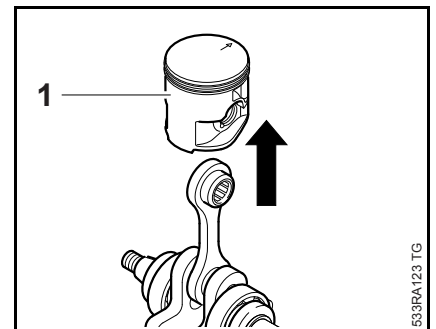

- Remove the piston (1) from the connecting rod.
- Inspect the piston rings and replace if necessary, [8.8.1](#)

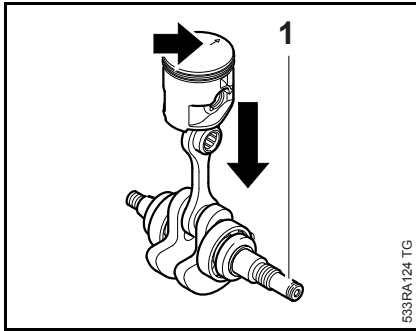

- Lubricate needle cage with oil.
- Line up the piston as shown in the illustration so that the mark (arrow) points to the rear and the long crankshaft stub (1) is on the right.
- Position the piston on the connecting rod.

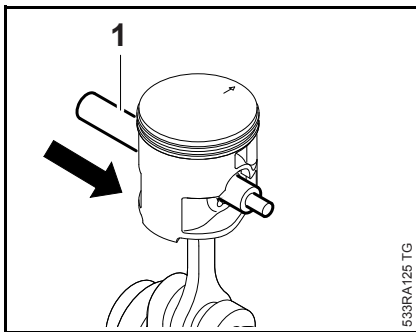

- Push the assembly drift (1) 1110 893 4700, small diameter first, through the piston and small end (needle cage) and line up the piston.

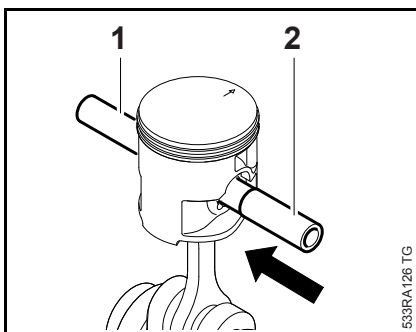

- Fit the piston pin (2) on the assembly drift (1) and slide it into the piston.

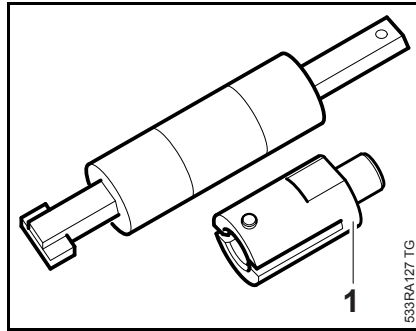

- Remove the sleeve (1) from the installing tool 5910 890 2210.

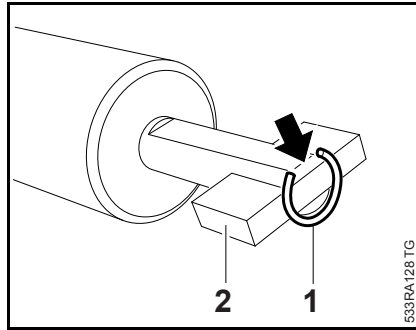

- Attach the snap ring (1) to the magnet (2) so that the snap ring gap is on the flat side of the tool's shank (arrow).

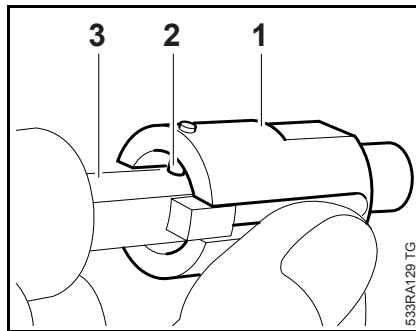

- Push the large slotted diameter of the sleeve (1) 5910 893 1707 over the magnet and snap ring.

The inner pin (2) must point towards the flat face (3) of tool's shank.

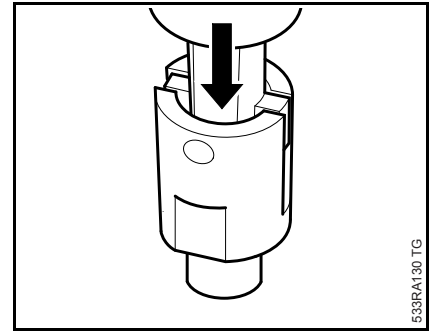

- Press the installing tool downwards into the sleeve until the magnet butts against the end of the guide slot.

Use a suitable base (wooden board).

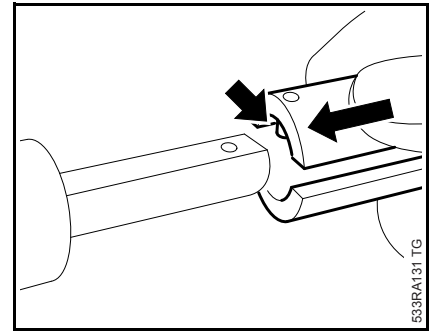

- Remove the sleeve and slip it onto the other end of the shank.

Inner pin (arrow) must point toward flat face.

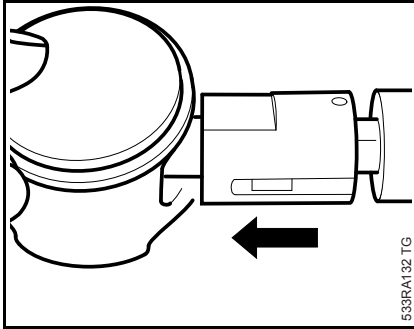

- Install the snap rings at both sides.
- Apply the installing tool 5910 890 2210 with the sleeve's taper against the piston boss, hold the piston steady, center the tool shank exactly and press home until the snap ring slips into the groove.

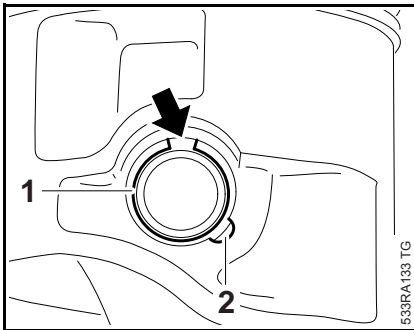

Fit the snap ring (1) so that its gap (arrow) points up. It must not be near the recess (2).

- Check position and security of both snap rings.

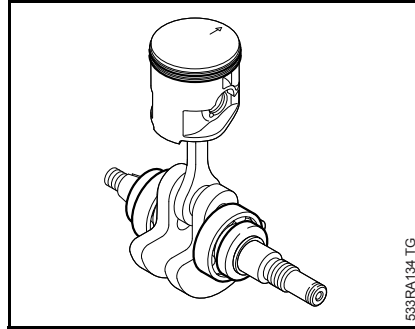

- Check the piston rings and replace if necessary., 8.8.1
- Check the oil seals and ball bearings and replace if necessary., 8.7
- Install the crankshaft, 8.6
- Install the engine, 8.5

8.8.1 Piston Rings

- Remove the piston, 8.8
- Remove the piston rings from the piston – the MS 171 has only one piston ring.

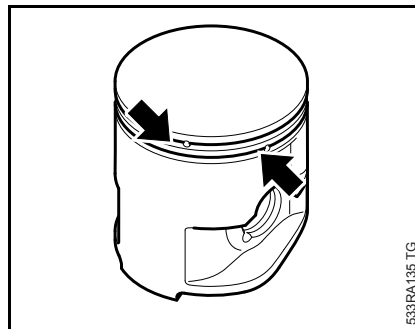

- Use a piece of old piston ring to scrape the grooves clean.

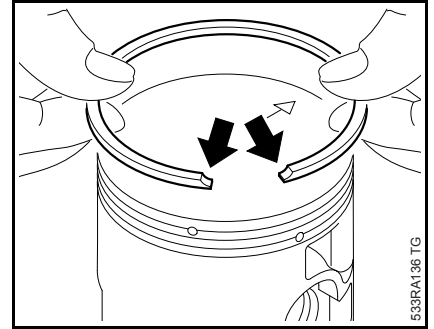

- Install the new piston rings in the grooves so that the radii face upward (arrows).

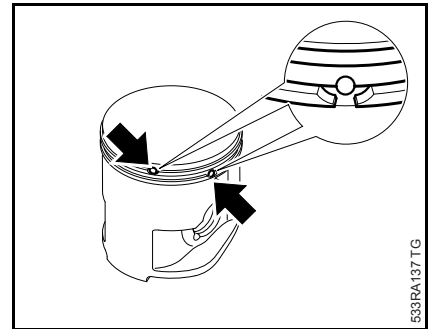



- Position the piston rings so that the radii at the ring gap meet at the fixing pin in the piston groove (arrows).
- Check correct installed position of the piston rings (arrows).
- Install the piston, 8.8

9. Ignition System

Exercise extreme caution when troubleshooting and carrying out maintenance or repair work on the ignition system. The high voltages which occur can cause serious or even fatal accidents.

Troubleshooting on the ignition system should always begin at the spark plug,  4.5

- Remove the fan housing,  10.1 and  10.2

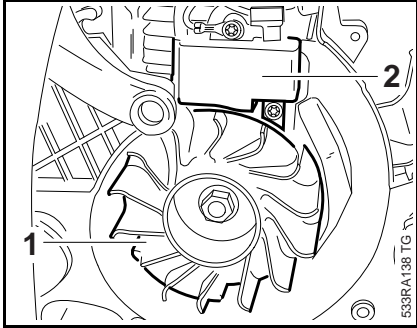

The electronic (breakerless) ignition system basically consists of an ignition module (2) and flywheel (1).

9.1 Ignition Module

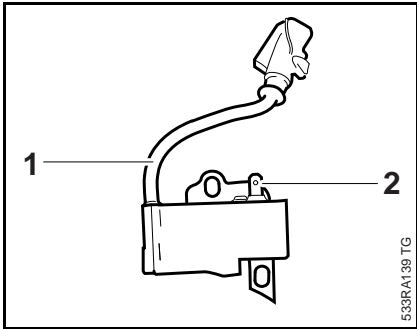

The ignition module accommodates all the components required to control ignition timing. There are two electrical connections on the coil body:



- the high voltage output with ignition lead (1)
- the connector tag (2) for the short circuit wire

Testing in the workshop is limited to a spark test. A new ignition module must be installed,  9.1, if no ignition spark is obtained (after checking that wiring and stop switch are in good condition).

Ignition timing is fixed and cannot be adjusted during repair work.

Since there is no mechanical wear in these systems, ignition timing cannot get out of adjustment.

9.1.1 Removing and Installing

- Remove the shroud,  8.4
- Remove the fan housing,  10.1 and  10.2

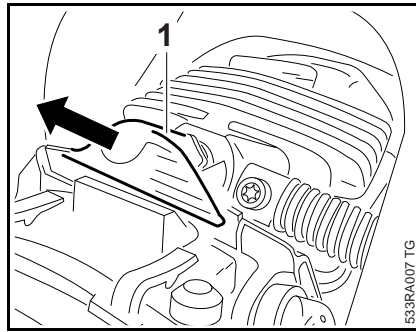

- Pull off the spark plug boot (1).

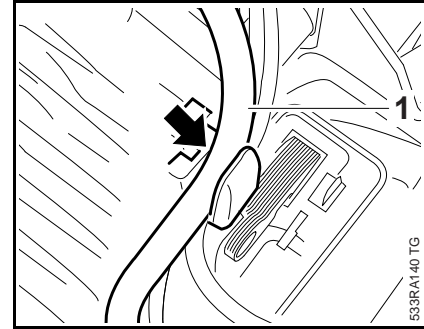

- Pull the ignition lead (1) out of the retainer (arrow).

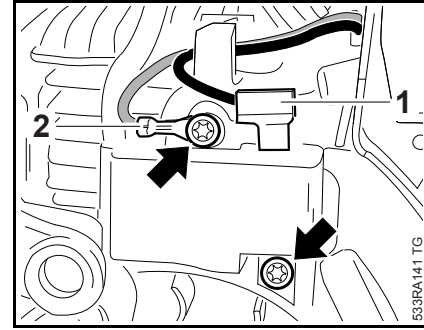

- Pull off the short circuit wire (1).
- Take out the screws (arrows).
- Remove the ground wire (2).

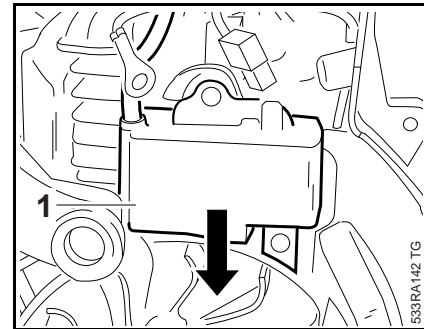

- Remove the ignition module (1).

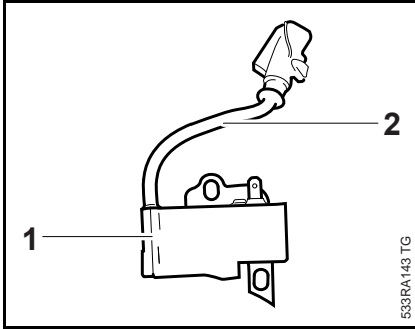

The ignition module (1) and ignition lead (2) are an assembly.

- Check the ignition module (1) and ignition lead and replace the ignition module if necessary.

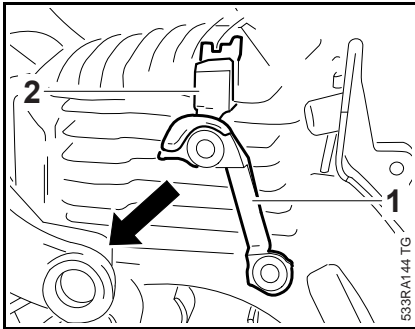

- Remove the insulator (1) and pull off the retainer (2).
- Check the retainer and insulator and replace if necessary.
- Check the spark plug boot and replace if necessary, [9.4](#)
- Troubleshooting, [4.5](#)

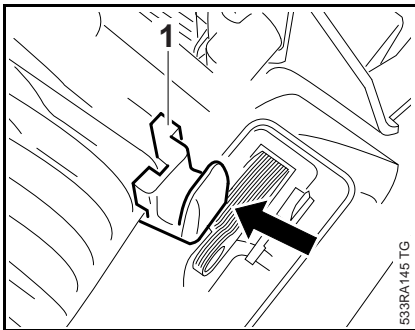

- Fit the retainer (1).

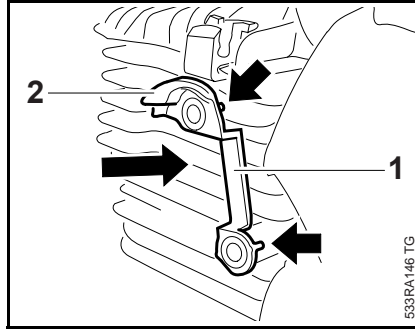

– Fit the insulator (1) so that the stop (2) is against the upper hole.

- Secure the insulator (1) with the lugs (arrows) on the bosses.

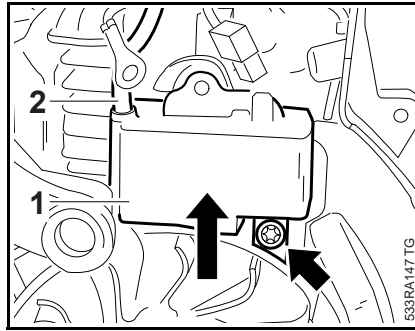

- Position the ignition module (1) so that the ignition lead (2) is on the left and insert the screw (arrow) with washer – do not tighten down yet.

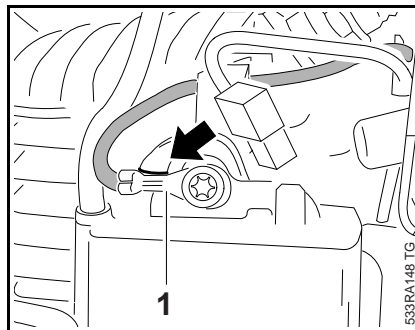

- Fit the wire terminal (1) so that it is against the stop (arrow) and insert the screw – do not tighten down yet.

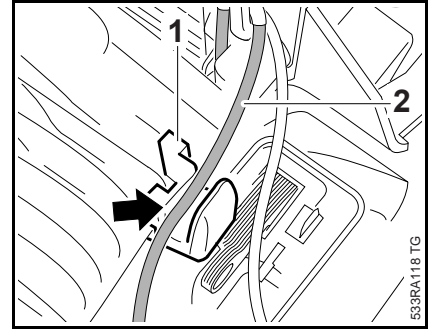

- Fit the ground wire (2) in the retainer (1) – ground wire must face the cylinder (arrow).

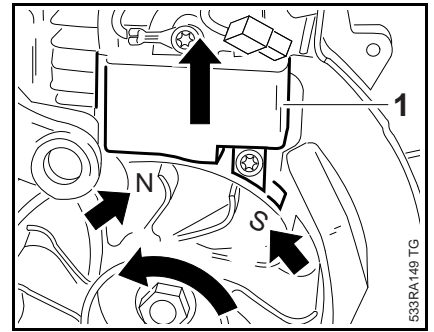

- Push the ignition module (1) back – the flywheel must turn freely.
- Rotate the flywheel until the magnet poles (arrows) are next to the ignition module.

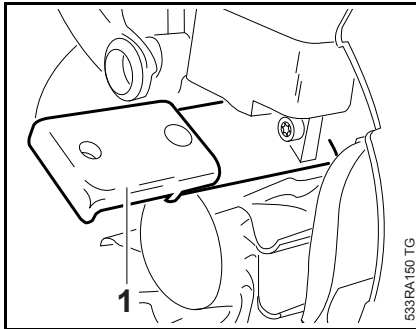

- Slide the setting gauge (1) 4118 890 6400 between the arms of the ignition module and the flywheel magnet.
- Press the ignition module against the setting gauge.
- Hold the ground wire terminal and tighten down the screws firmly.
- Tightening torques, 3.5
- Remove the setting gauge.
- Check operation
 - rotate the flywheel and make sure it does not touch the ignition module.

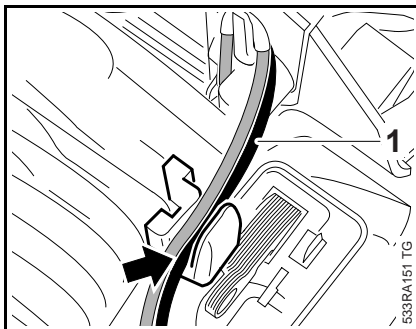

- Fit the short circuit wire (1) in the retainer (arrow) and reconnect it.

Short circuit and ground wires must be next to one another in the retainer – ground wire must face the cylinder.

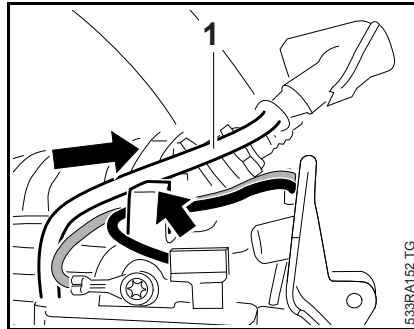

- Push the ignition lead (1) into the retainer (arrow) and pull it a little in the direction of the air filter.
- Fit the boot on the spark plug.
- Reassemble all other parts in the reverse sequence.

9.2 Ignition Timing

Ignition timing is fixed and cannot be adjusted during repair work.

Since there is no mechanical wear in these systems, ignition timing cannot get out of adjustment..

9.3 Testing the Ignition Module

To test the ignition module, use either the ZAT 4 ignition system tester 5910 850 4503 or the ZAT 3 ignition system tester 5910 850 4520.

The ignition test refers only to a spark test, not to ignition timing.

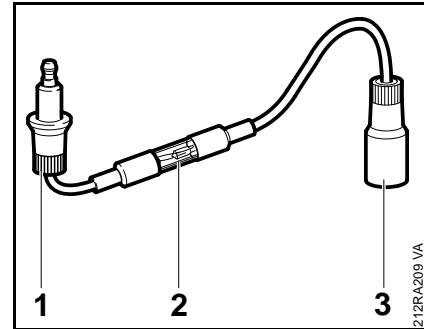

Using the ZAT 4 ignition tester 5910 850 4503

- Before starting the test, install a new spark plug in the cylinder and tighten it down firmly.
- Tightening torques, 3.5

- Connect spark plug boot to the input terminal (1). Push the tester's output terminal (3) onto the spark plug

High voltage – risk of electric shock.

- Crank the engine quickly with the rewind starter and check spark in the tester's window (2).

The engine may start and accelerate during the test.

If a spark is visible, the ignition system is in order.

If no spark is visible in the window (2), check the ignition system with the aid of the troubleshooting chart, 9.7

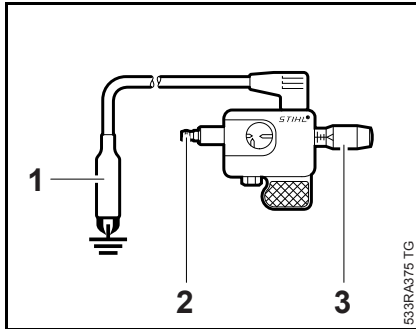

Using ZAT 3 ignition tester 5910 850 4520

- Before starting the test, install a new spark plug in the cylinder and tighten it down firmly
- Tightening torques, [1](#) 3.5
- Connect spark plug boot to the terminal (2).
- Attach ground terminal (1) to the spark plug.
- Use adjusting knob (3) to set spark gap to about 2 mm.

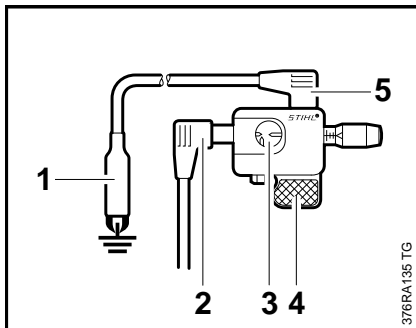

While using the ZAT 3, hold it only by the handle (4) or position it in a safe place. Keep fingers or other parts of your body at least 1 cm away from the spark window (3), high voltage connection (2), ground connection (5) and the ground terminal (1).

High voltage – risk of electric shock.

- Crank the engine quickly with the rewind starter and check spark in the tester's window (3).

The engine may start and accelerate during the test.

If a spark is visible, the ignition system is in order.

If no spark is visible in the window (3), check the ignition system with the aid of the troubleshooting chart, [1](#) 9.7

9.4 Spark Plug Boot

The ignition module and ignition lead are an assembly. If the ignition lead is damaged, install a new ignition module.

- Remove the shroud, [1](#) 8.4
- Pull the boot off the spark plug.

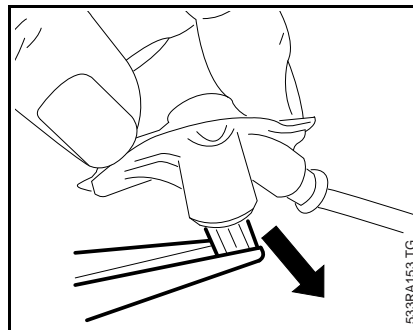

- Use suitable pliers to pull the leg spring out of the spark plug boot.
- Unhook the leg spring from the ignition lead.
- Pull the boot off the ignition lead.

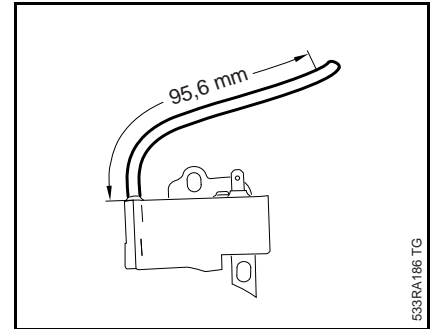

- Use a pointed tool to pierce the center of the ignition lead's insulation, 95.6 mm from the end of the lead.

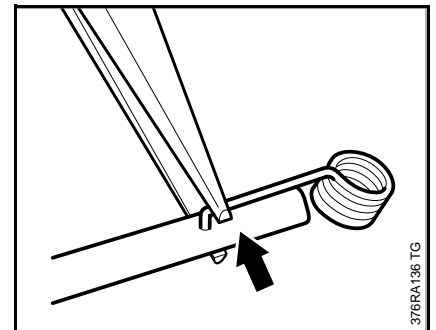

- Pinch the hook of the leg spring into the center of the lead (arrow).

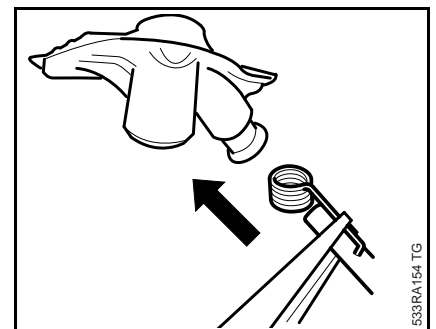

- Coat inside of spark plug boot with STIHL Press Fluid, [1](#) 16
- Hold the ignition lead and leg spring together and push them into the spark plug boot.

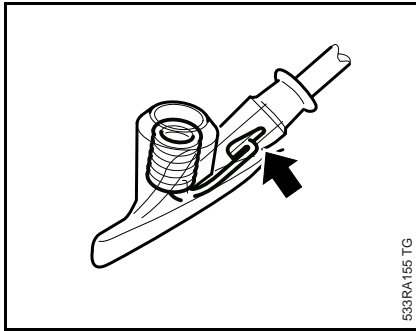

533RA156 TG

- Make sure the leg spring (arrow) locates properly inside the spark plug boot.

Do not use either graphite grease or silicone insulating paste.

- Reassemble all other parts in the reverse sequence.

9.5 Flywheel

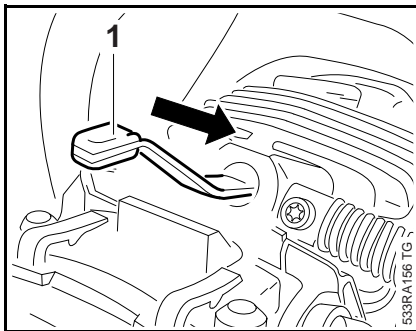

533RA156 TG

- Remove the shroud, 8.4
- Block the piston with the locking strip (1), 6

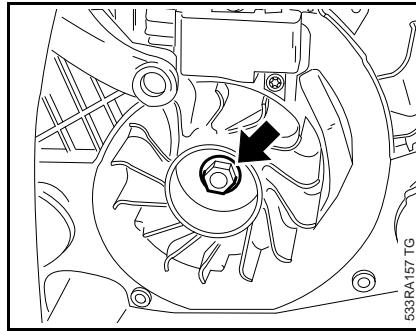

533RA157 TG

- Unscrew the flywheel nut (arrow).

If the flywheel is stuck, use the puller.

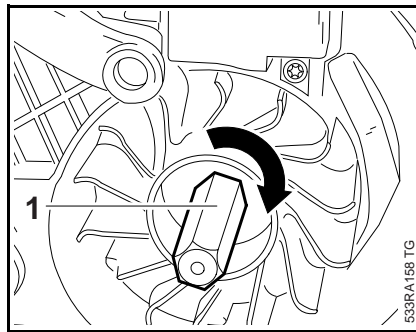

533RA158 TG

- Screw on the puller (1) 1116 893 0800 clockwise as far as stop and then turn it back a quarter turn.
- Tap the end of the puller a few times to release the flywheel.

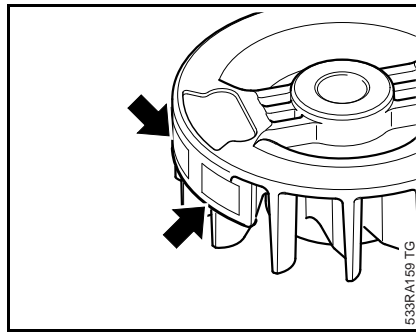

533RA159 TG

- Unscrew the puller and remove the flywheel.

Inspect flywheel (1) and magnet poles (2) for cracks or other damage. If it is damaged or has turned blue, install a new flywheel.

The flywheel bore and crankshaft stub must be free from grease, 16.

- On machines with ErgoStart, check the pawls and replace if necessary, 10.4

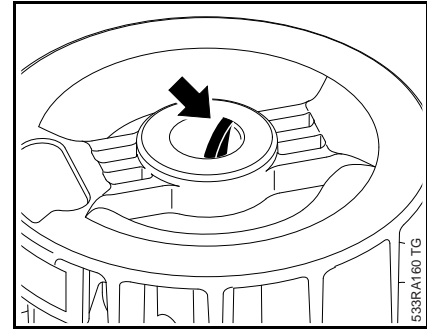

533RA160 TG

- Make sure the key (arrow) engages the slot in the crankshaft stub.
- Check air gap between ignition module and flywheel and adjust if necessary, 9.1.1
- Reassemble all other parts in the reverse sequence.
- Tightening torques, 3.5

9.6 Short Circuit Wire

9.6.1 Testing

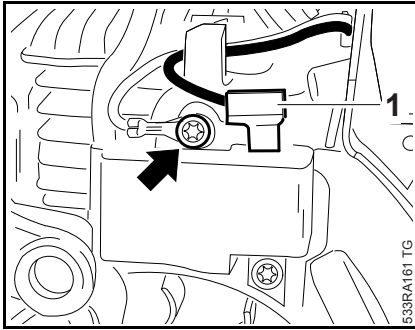

If the spark plug, ignition lead and spark plug boot are in order, check the short circuit wire.

- Remove the shroud, [8.4](#)
- Remove the fan housing, [10.1](#) and [10.2](#)
- Disconnect short circuit wire (1).
- Connect the ohmmeter to ground (arrow) and the short circuit (1).
- Set the Master Control lever to “0”.

The resistance measured must be about 0 Ω. If it is much higher, the reason is a break and the wire has to be replaced, [9.6.2](#)

- Set the Master Control lever “I”.

The resistance measured must be infinitely high. If not, fit a new short circuit wire, [9.6.2](#)

If no fault can be found, check the ignition system with the aid of the troubleshooting chart, [9.7](#)

- Check ground wire for continuity.
- Install in the reverse sequence.

9.6.2 Removing and Installing

The short circuit and ground wires are combined in a wiring harness. If damaged, the complete wiring harness must be replaced.

When cleaning the machine, take care not to disconnect wires.

- Remove the shroud, [8.4](#)
- Remove the fan housing, [10.1](#) and [10.2](#)
- Remove the carburetor, [14.3](#)

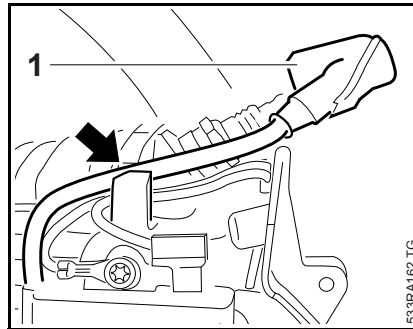

- Pull off the spark plug boot (1).
- Pull the ignition lead out of the retainer (arrow).

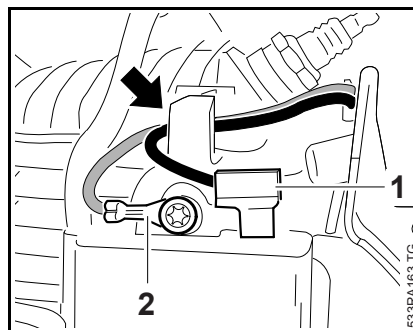

- Take out the screw and remove the ground wire (2).

- Disconnect short circuit wire (1).
- Pull the short circuit and ground wires out of the retainer (arrow).

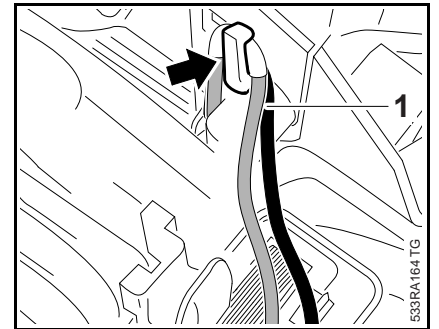

- Remove the wiring harness (1) from the guide (arrow) – do not move the cable tie.
- Remove the carburetor carrier, [14.7.1](#)

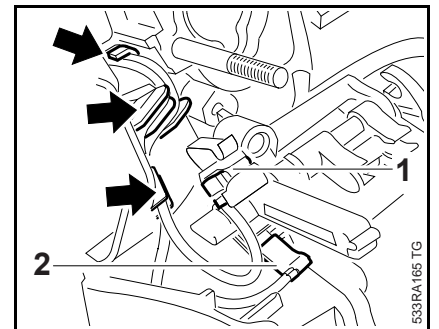

- Pull the short circuit and ground wires out of the guides (arrows).
- Disconnect connectors of short circuit wire (1) and ground wire (2).
- Remove the wiring harness.

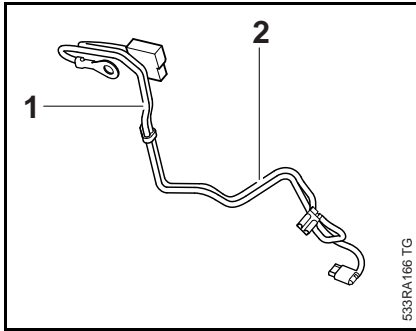

- Check the short circuit wire (1) and ground wire (2) and replace wiring harness if necessary.

A faulty ground wire can impair or prevent operation of the short circuit wire. For this reason also check the ground wire for contact and continuity.

Installing

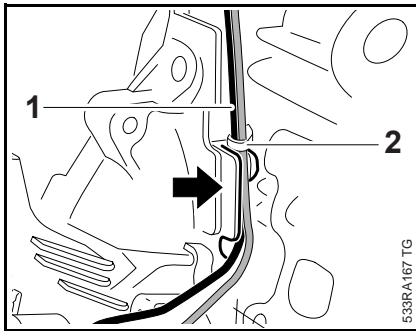

The following steps are shown without the manifold for greater clarity.

- Push the wiring harness, short circuit wire (1) first, into the guide (arrow).

The cable tie (2) must rest on the guide and point in the direction of the cylinder – do not move the cable tie on the wiring harness.

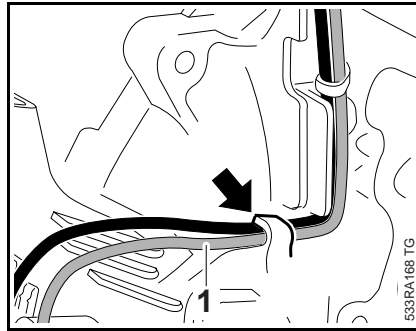

- Fit the wiring harness (1) along the housing and push it, ground wire first, completely into the guide (arrow).

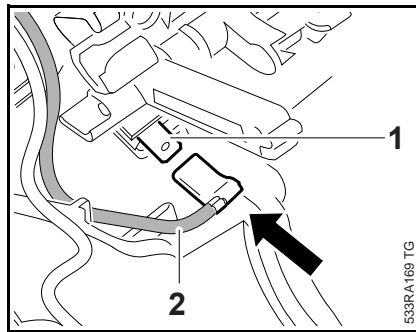

- Push ground wire connector with protective tube (2) onto the contact spring (1).

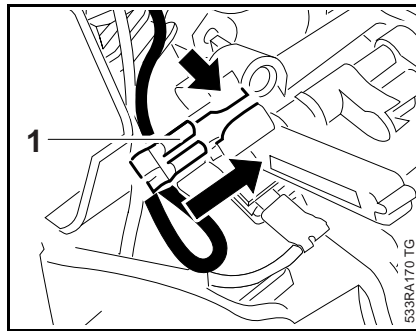

- Push short circuit wire connector (1) into receptacle on switch shaft (arrow) as far as stop.

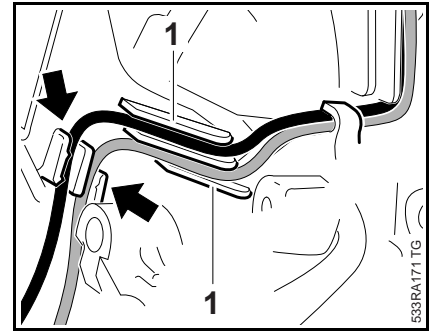

- Press the wires into the guides (1) first, then into the guides (arrows).

The wires must be against the housing and must not cross each other.

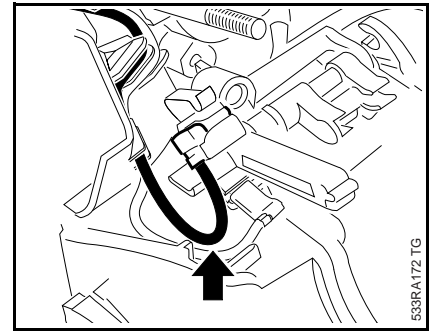

The short circuit wire must be looped (arrow) so that it can move with the switch shaft.

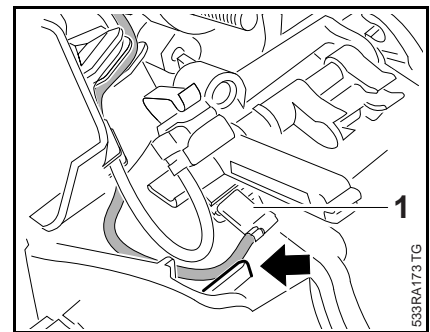

- Position the ground wire (1) against the protective rib (arrow) – to avoid unintentional disconnection.

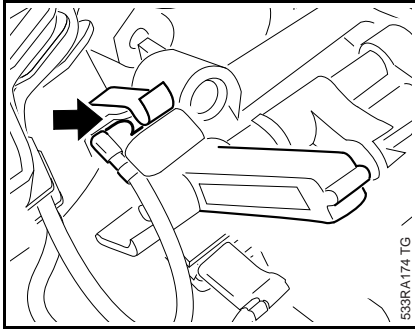

- Check operation
 - the short circuit wire's connector must touch the contact spring (arrow) in position "0".
- Install the carburetor carrier, [14.7.1](#)

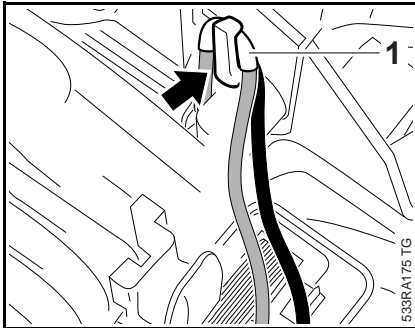

- Attach the wires, short circuit wire first, to the guide (arrow)
 - the protective tube (1) must engage the guide.
- Fit the ground and short circuit wires in the retainer and connect them up, [9.1.1](#)
- Install the ignition lead, [9.1](#)
- Check air gap on ignition module and adjust if necessary, [9.1.1](#)
- Reassemble all other parts in the reverse sequence.
- Tightening torques, [3.5](#)

9.6.3 Ground Wire

A faulty ground wire can impair or prevent operation of the short circuit wire. Always check ground wire for contact and continuity.

The short circuit and ground wires are combined in a wiring harness. If damaged, the complete wiring harness must be replaced.

- Check for contact and continuity and replace wiring harness if necessary, [9.6.1](#)
- Remove and install wiring harness, [9.6.2](#)

9.6.4 Contact Spring

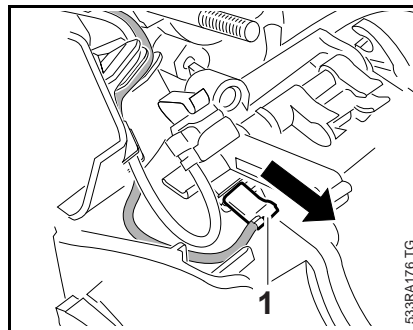

- Remove the switch shaft, [12.1](#)
- Disconnect the ground wire (1).

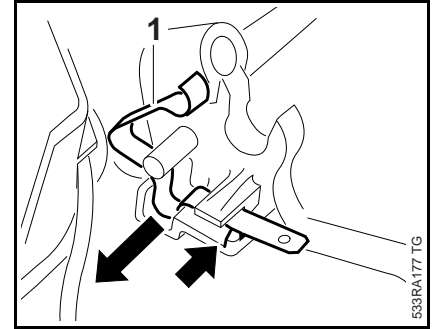

- Ease the contact spring (1) over the lug (arrow) and pull it out.
- Check contact spring and replace if necessary.

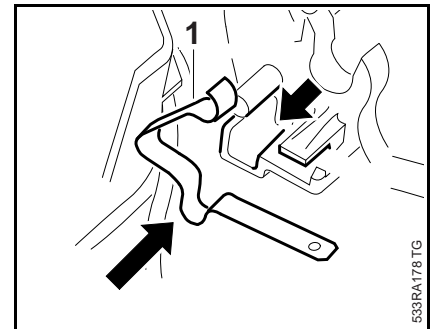

- Push the contact spring (1) into the guide so that it lines up with the recess (arrows).

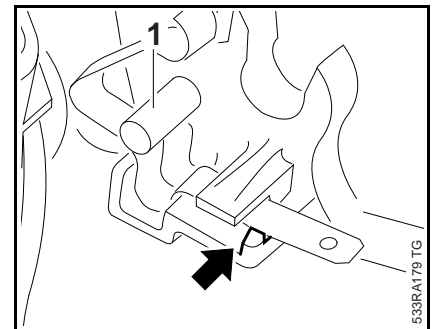

- Push the contact spring (1) into its seat until the lug (arrow) snaps into position.

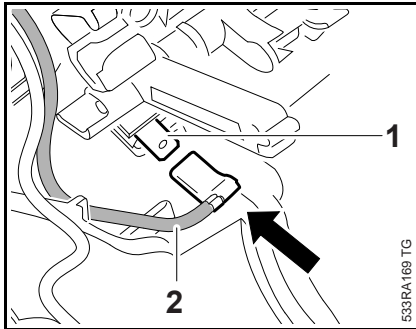

- Install the switch shaft, 12.1
- Push ground wire connector with protective tube (2) onto the contact spring (1).

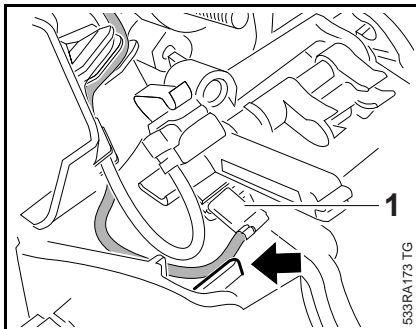

- Position the ground wire (1) against the protective rib (arrow)
 - to avoid unintentional disconnection

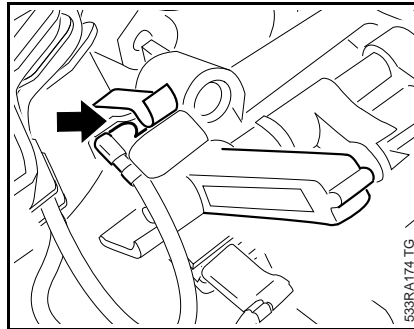

- Check operation
 - the short circuit wire's connector must touch the contact spring (arrow) in position "0".
 - The ground and short circuit wires must be laid close to the housing and properly seated in the guides, 9.6.2
 - Reassemble all other parts in the reverse sequence.
 - Tightening torques, 3.5

9.7 Ignition System Troubleshooting

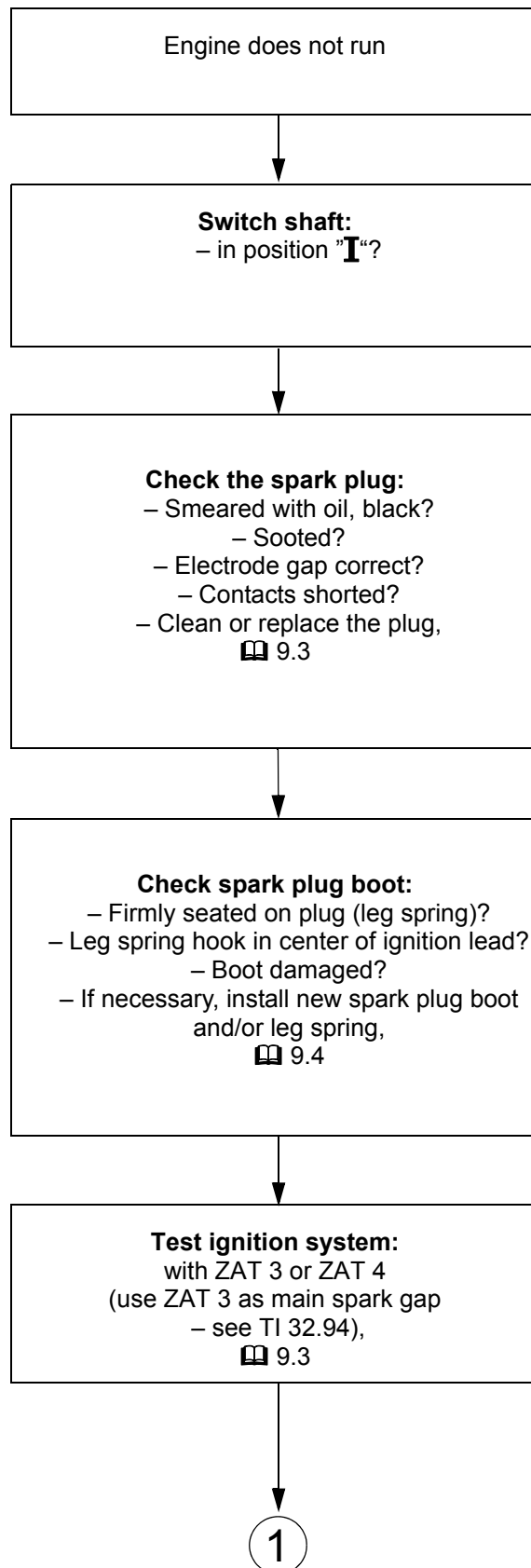

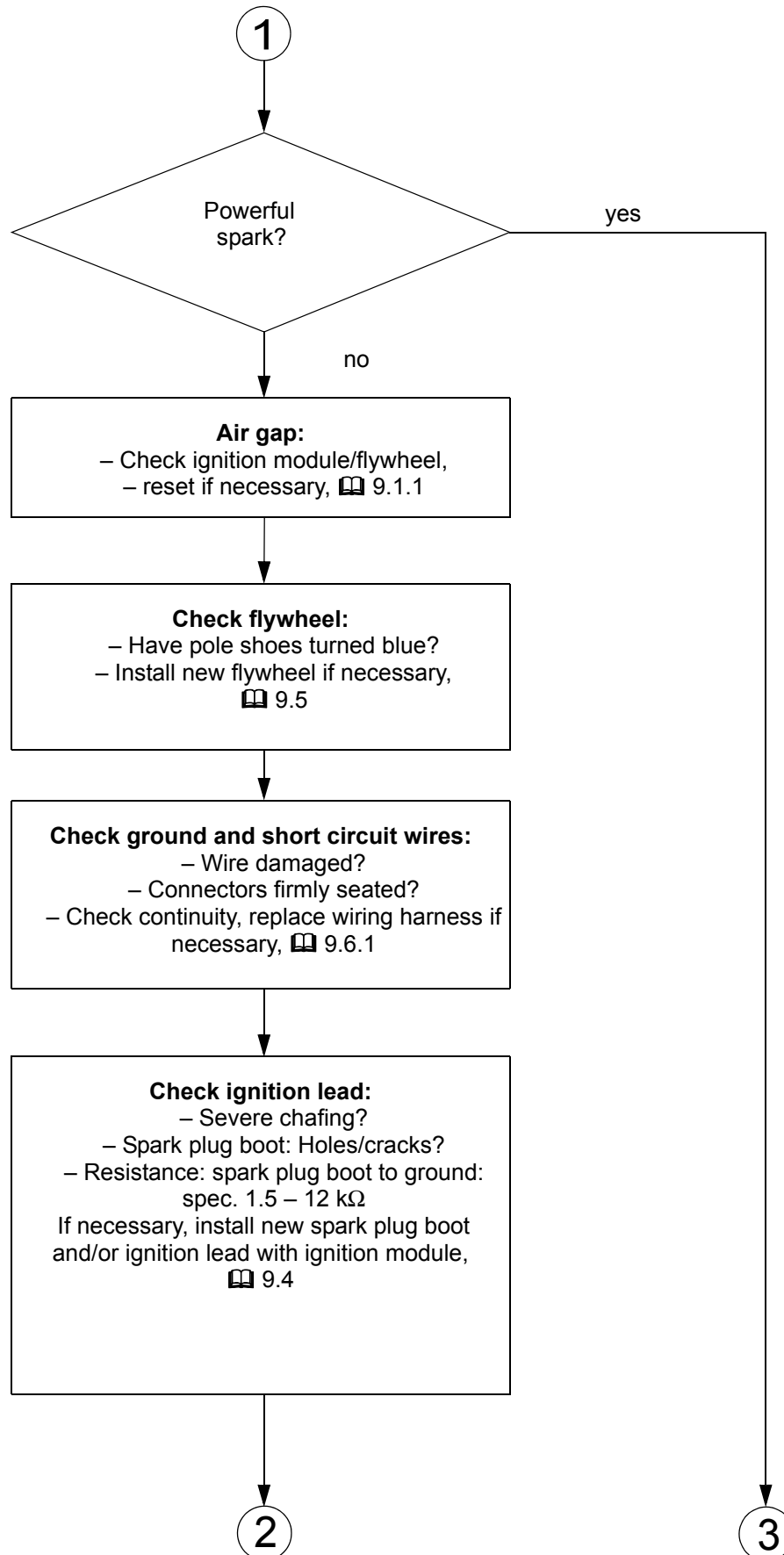

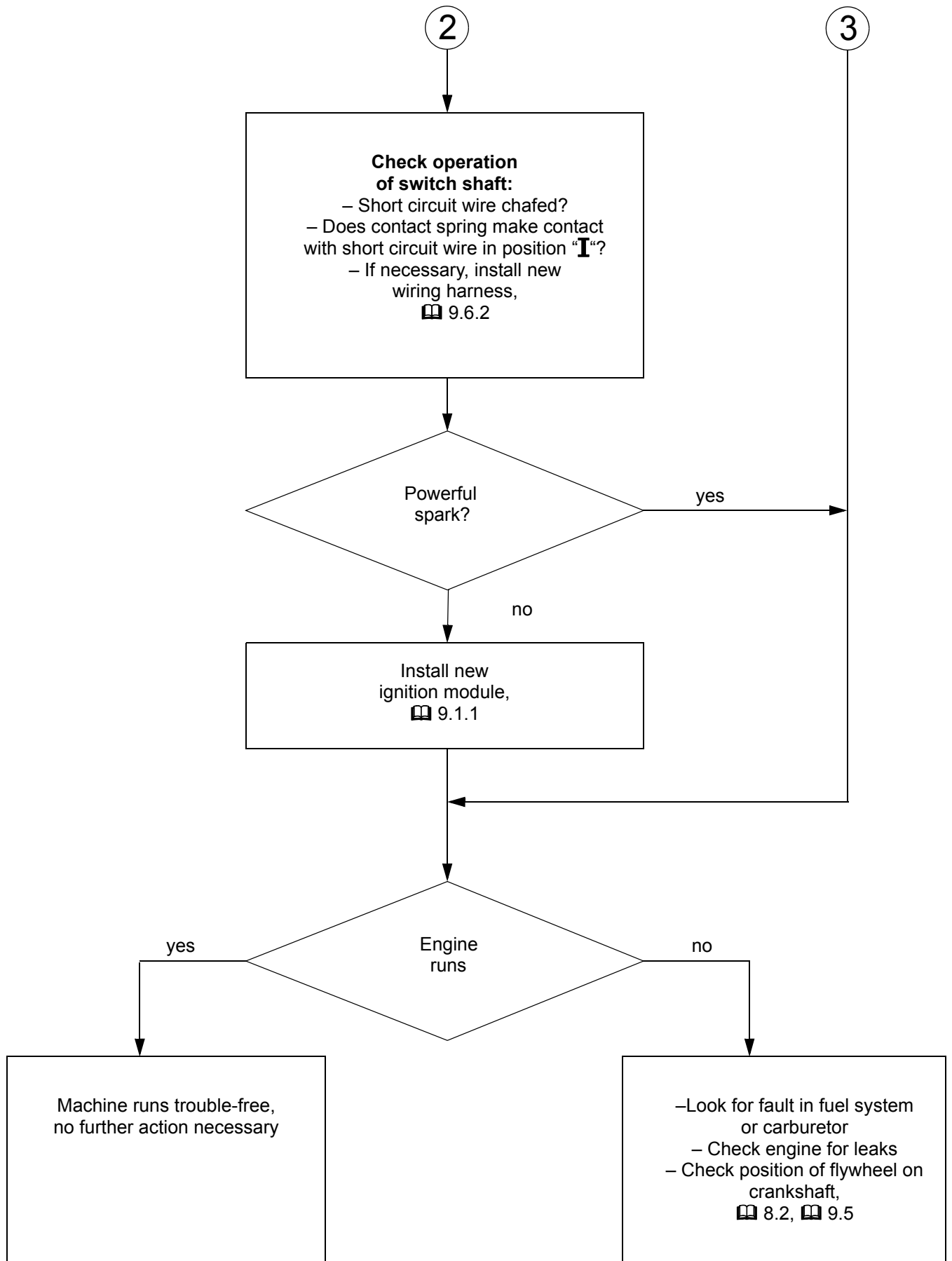

10. Rewind Starter

10.1 General

If the action of the starter rope becomes very stiff and the rope rewinds very slowly or not completely, it can be assumed that the starter mechanism is in order but plugged with dirt. At very low outside temperatures the lubricating oil on the rewind spring may thicken and cause the spring windings to stick together. This has a detrimental effect on the function of the starter mechanism.

In such a case it is sufficient to apply a few drops of a standard solvent-based degreasant (containing no chlorinated or halogenated hydrocarbons) to the rewind spring.

Carefully pull out the starter rope several times and allow it to rewind until its normal smooth action is restored.

Before installing, lubricate the rewind spring and starter post with STIHL special lubricant.

If clogged with dirt or pitch, the entire starter mechanism, including the rewind spring, must be removed and disassembled. Take particular care when removing the spring.

– Clean all components,  16

Machines with ErgoStart

– Relieve tension of spring,  10.4

10.2 Removing and Installing

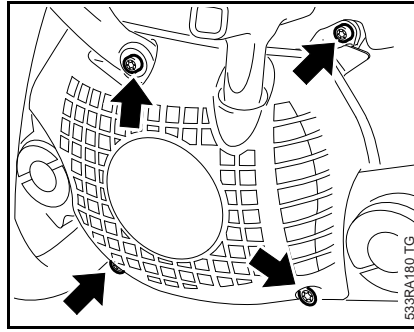

– Remove the shroud,  8.4

- Turn the starter grip sideways and take out the screws (arrows).

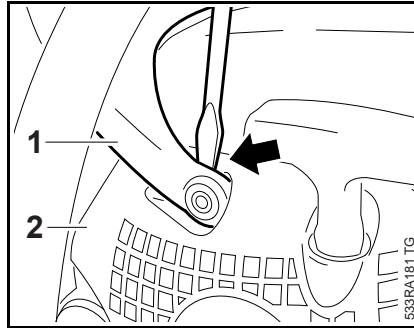

– Use a screwdriver to pry the hand guard (1) off the boss (arrow) and remove the fan housing (2).

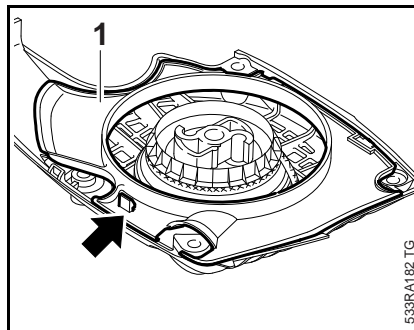

- Push the locking tab (arrow) to one side and take out the segment (1).

– Check the fan housing and segment and replace if necessary.

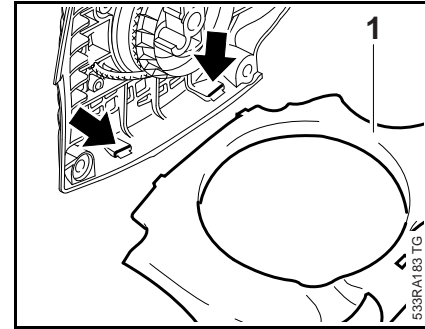

- Fit the segment (1) in the slots (arrows) in the fan housing, then push it into the locking tab until it snaps into position.

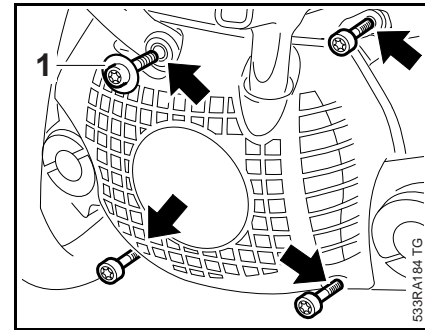

- Fit and tighten down the screws (arrows) firmly – the hand guard is secured with the screw (1) and washer.

– Tightening torques,  3.5

10.3 Pawl

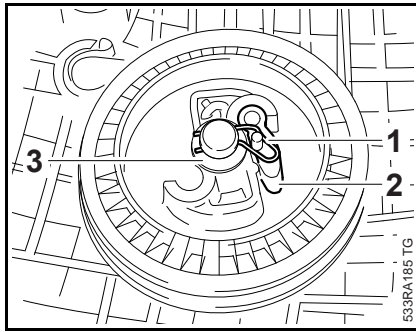

- Remove the fan housing, 10.1 and 10.2
- Grip the straight end of the spring clip (1) and ease it off the starter post – the rewind spring may pop out during this operation.
- Remove and inspect the pawl (2), clean or replace if necessary.
- Lubricate seat of new pawl with grease, 16
- Fit the new pawl and lubricate its peg with resin-free oil, 16

Check that washer (3) is in place.

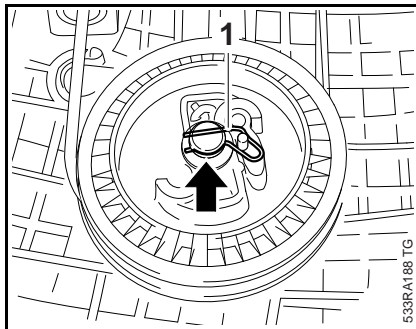

- Position the spring clip (1) so that its loop engages the peg on the pawl and its curved part (arrow) is in the starter post's groove.

- Push the straight part of the spring clip over the starter post until it snaps into the groove.

- Reassemble all other parts in the reverse sequence.

Machines with ErgoStart

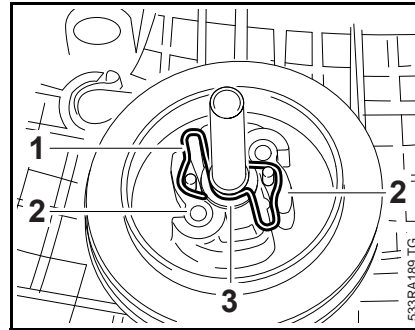

- Remove the ErgoStart, 10.4
- Grip the straight part of the spring clip (1), ease it out of the groove and pull the spring clip off the starter post – the rewind spring may pop out during this operation.
- Remove and inspect the pawls (2), clean or replace if necessary.
- Lubricate seat of new pawls with grease, 16
- Fit the new pawls and lubricate their pegs with resin-free oil, 16

Check that washer (3) is in place.

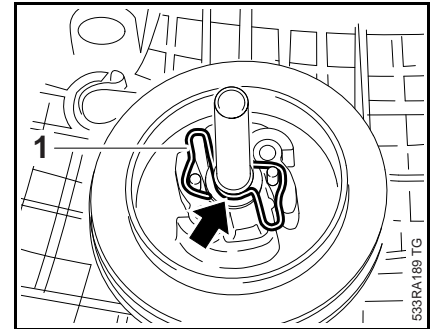

- Position the spring clip (1) so that its loops engage the pegs on the pawls and its curved part (arrow) is in the starter post's groove.
- Push the straight part of the spring clip over the starter post until it snaps into the groove.
- Reassemble all other parts in the reverse sequence.

10.4 ErgoStart

The spring may still be under tension. Always relieve tension of spring as follows before installing:

- Pull out the starter rope until the engine turns – tension is now relieved.
- Remove the fan housing and, if necessary, the segment, 10.1 and 10.2

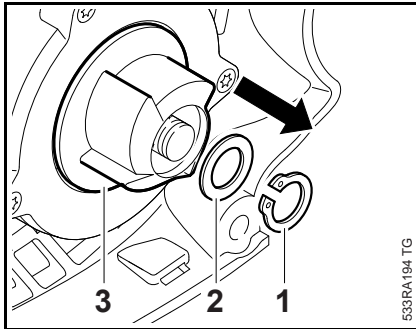

- Remove the circlip (1)
– do not overstretch.
- Remove the washer (2).
- Pull off the carrier (3).

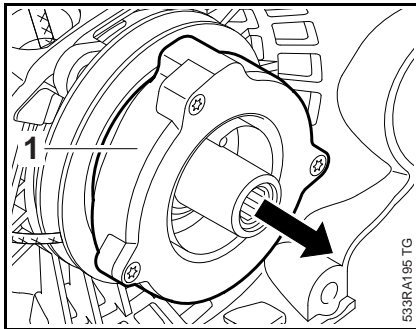

- Pull off the spring housing (1).
- Remove the washer.

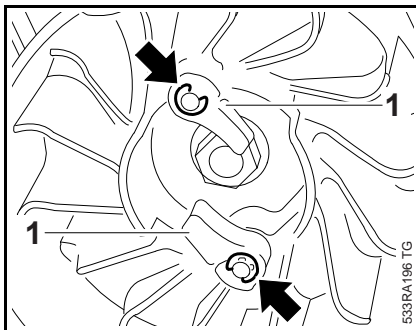

- Remove the E-clips (arrows).
- Pull off the pawls (1) and remove the torsion springs.
- Clean the pawls (1),  16

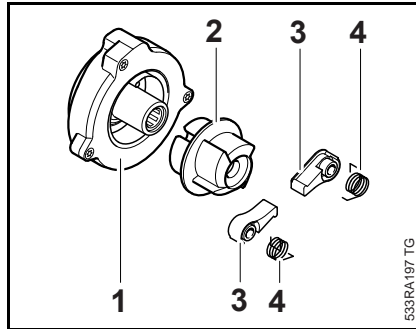

- Inspect the spring housing (1), carrier (2), pawls (3) and torsion springs (4) and replace if necessary.

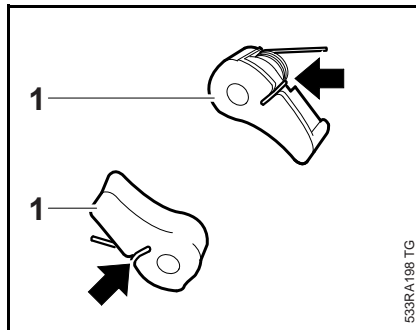

- Fit torsion springs in the pawls (1)
– note installed position (arrows).

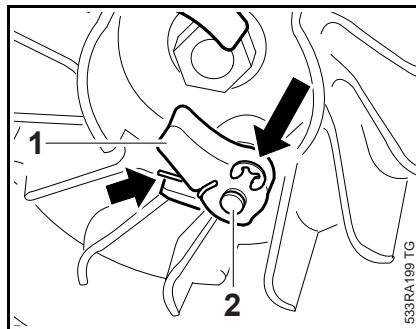

- Push the pawls (1) onto the pivot pins (2) on the flywheel and locate the ends of the torsion springs against the ribs (arrow).
- Install the E-clips.

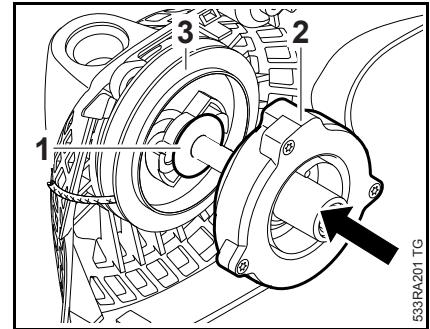

- Fit the washer (1).
- Push the spring housing (2) over the starter post and onto the pawls in the rope rotor (3) – the pawls must engage the spring housing.

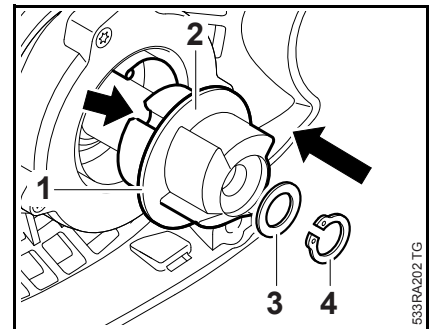

- Push the carrier (1) into the spring housing so that the recess (arrow) engages the spring loop (2).
- Fit the washer (3).
- Install the circlip (4)
– do not overstretch.
- Reassemble all other parts in the reverse sequence.

10.5 Rope Rotor

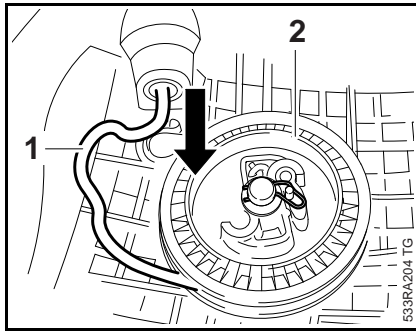

Relieving tension of rewind spring

- Remove the fan housing and, if necessary, the segment, [10.1](#) and [10.2](#)

Machines with ErgoStart

- Remove the ErgoStart, [10.4](#)

All machines

- Pull out the starter rope (1) about 5 cm and hold the rope rotor (2) steady.
- While still holding the rope rotor steady, take three full turns off the rope rotor.
- Pull out the rope with the starter grip and slowly release the rope rotor.
- Remove the starter rope or remaining rope from the rotor, [10.6](#)

The system will not be under tension if either the starter rope or rewind spring is broken.

- Remove the spring clip and pawl(s), [10.3](#)

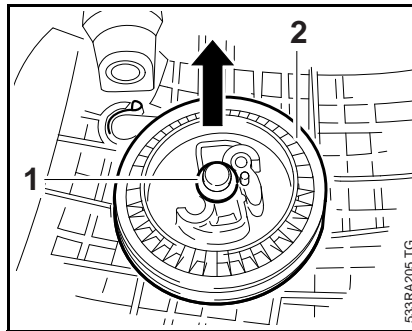

- Remove the washer (1).

Rewind spring must be relaxed.

- Carefully remove the rope rotor (2) – the rewind spring may pop out and uncoil.
- Check the rope rotor and replace if necessary.
- Coat bore in rope rotor with STIHL special lubricant, [16](#)

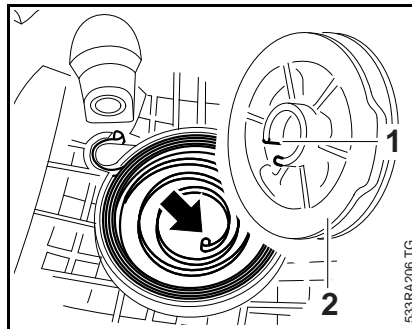

- Lubricate starter post with oil, [16](#)

- Fit the rope rotor (2) on the starter post so that the inner spring loop (arrow) engages the recess (1).
- Fit the washer.
- Install the pawl(s) and spring clip, [10.3](#)

- Install the starter rope, [10.6](#)
- Tension the rewind spring, [10.7](#)
- Lubricate the peg(s) on the pawl(s) with grease, [16](#)

10.6 Starter Rope / Grip

- Remove the fan housing and, if necessary, the segment, [10.1](#) and [10.2](#)

Machines with ErgoStart

- Remove the ErgoStart, [10.4](#)

All machines

- Relieve tension of rewind spring, [10.5](#)

The system will not be under tension if either the starter rope or rewind spring is broken.

- Remove remaining rope from the rope rotor and starter grip.

Do not shorten the starter rope.

- Remove the rope rotor, [10.5](#)

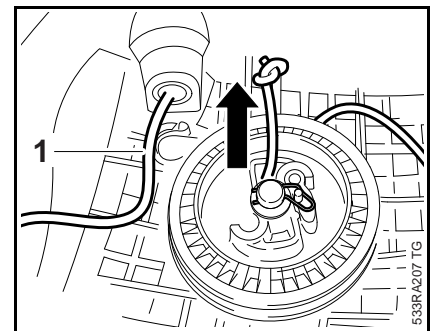

- Push the end of the starter rope (1) out a little and undo the knot.
- Pull the starter rope out of the rope rotor and fan housing.

Standard Starter Grip

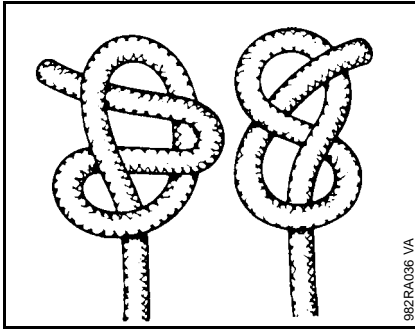

982RA036 VA

- Pull the old rope out of the starter grip.
- Tie one of the special knots shown in the end of the new rope.

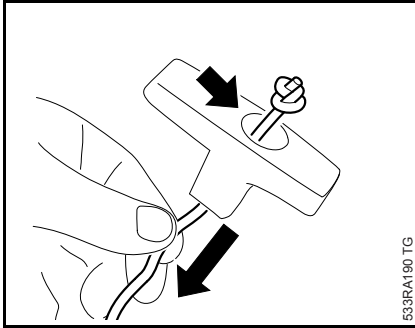

533RA190 TG

- Thread the starter rope through the top of the starter grip.
- Pull the starter rope through the grip until the knot is seated in the recess (arrow).

Elastostart Starter Grip

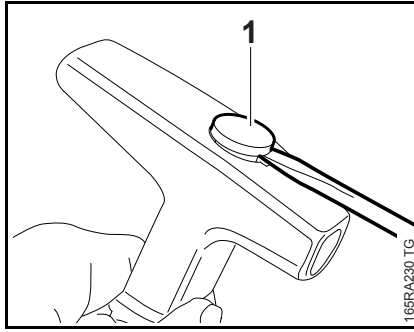

169RA230 TG

- Use a suitable tool to pry the cap (1) out of the starter grip.

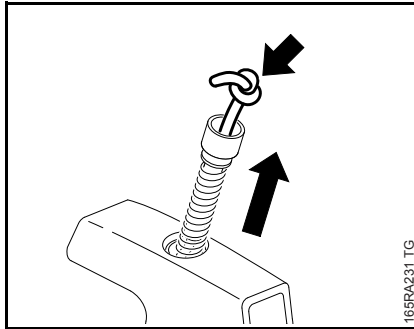

169RA231 TG

- Pull the sleeve, washers, spring and rope (arrow) out of the grip.
- Pull any remaining rope out of the sleeve. Inspect the individual parts and replace if necessary.

Do not shorten the starter rope.

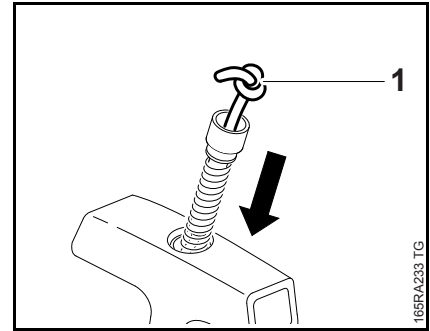

169RA233 TG

- Thread the new starter rope through the sleeve.
- Tie a simple overhand knot in the end of the rope.
- Fit the washers and spring.
- Pull the starter rope with sleeve, spring and washers into the starter grip (1).

Make sure the washers and spring remain on the sleeve while the rope is being pulled into the grip.

- Position cap so that its lug engages the slot in the starter grip.
- Press the cap into the starter grip.

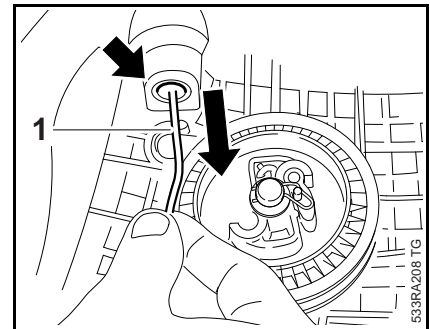

533RA208 TG

- Thread the starter rope (1) through the guide bushing (arrow).

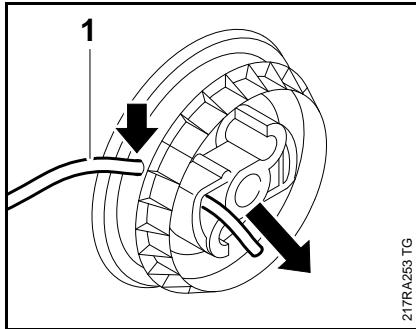

- Thread the starter rope (1) through the side of the rope rotor (arrow).

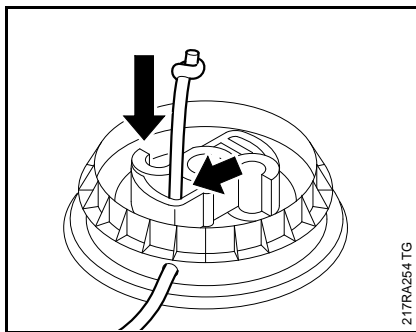

- Secure the rope with a simple overhand knot.
- Pull rope back until knot locates in recess (arrow) in rope rotor.
- Install the rope rotor and tension the rewind spring, 10.5, 10.7
- Install the fan housing and, if necessary, the segment, 10.1 and 10.2

10.7 Tensioning the Rewind Spring

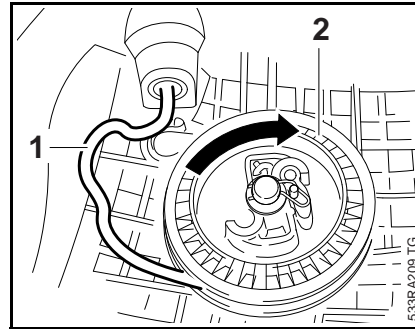

- Remove the fan housing and, if necessary, the segment, 10.1 and 10.2
- Pull out a short length of starter rope (1).
- Use the starter rope (1) to rotate the rope rotor (2) six turns clockwise.

Pawl(s) and spring clip must be installed.

Rotating the rope and rope rotor causes the rope to become twisted. The rewind spring is now tensioned.

Hold the rope rotor steady since it will otherwise spin back and may damage the rewind spring.

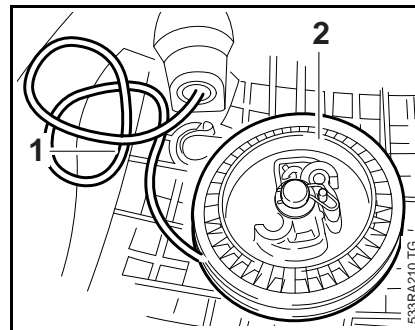

- Hold the rope rotor (2) steady.
- Pull out the twisted rope (1) with the starter grip and straighten it out.

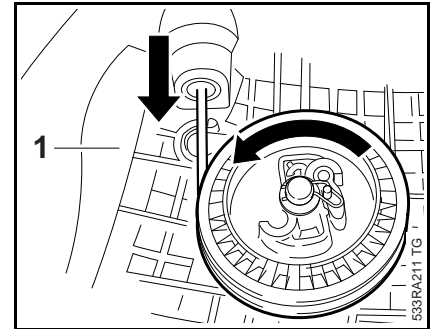

- Hold the starter grip (1) firmly to keep the rope tensioned.
- Let go of the rope rotor and slowly release the starter rope so that it can rewind properly.

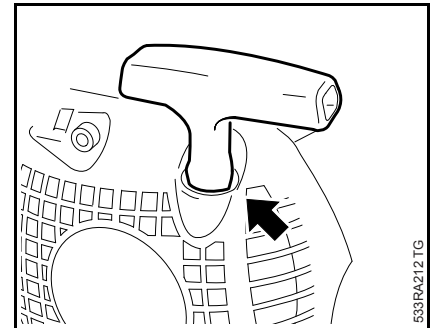

The rewind spring is correctly tensioned when the starter grip sits firmly in the rope guide bushing (arrow) without drooping to one side. If this is not the case, tension the spring by one additional turn.

When the starter rope is fully extended, it must still be possible to rotate the rope rotor at least another half turn before maximum spring tension is reached. If this is not the case, reduce spring tension since there is otherwise a risk of breakage.

To reduce spring tension: Pull the rope out, hold the rope rotor steady and take off one turn of the rope.





- Install the fan housing and, if necessary, the segment, 10.1 and 10.2

10.8 Replacing the Rewind Spring

- Troubleshooting,  4.4

The replacement spring comes ready for installation in a spring housing.

Wear a face shield and work gloves.

- Remove the fan housing and, if necessary, the segment,  10.1 and  10.2
- Relieve tension of rewind spring if necessary and remove the rope rotor,  10.5
- Remove any remaining pieces of old spring.
- Lubricate the spring with a few drops of STIHL special lubricant before installing,  16

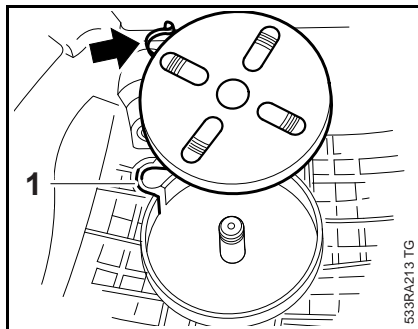

- Place the replacement spring with housing in position – the spring's anchor loop (arrow) must locate over the lug (1).

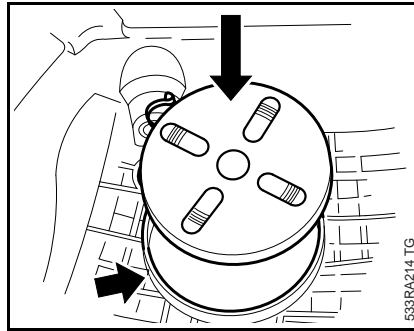

- Push the rewind spring with housing as far as stop into its seat (arrow) in the fan housing.

The rewind spring may pop out during this process.

- Remove the spring housing.

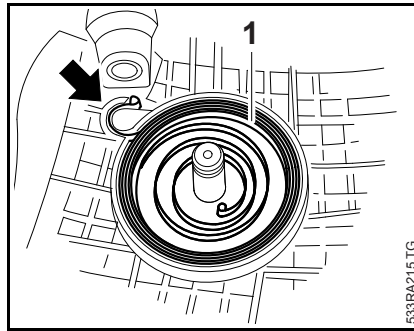

Check that the new rewind spring (1) is properly seated and the anchor loop is engaged on the lug (arrow).

If the rewind spring has popped out, refit it in the fan housing as follows:

- Arrange the spring in its original position.

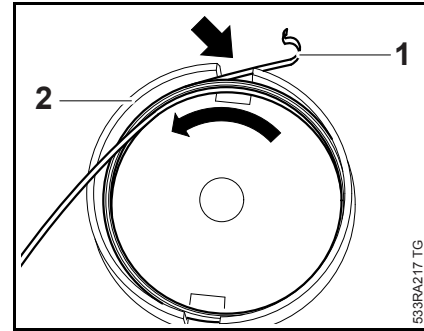

- Place anchor loop (1) in the opening (arrow) in the installing tool (2) 1116 893 4800.

Make sure the anchor loop does not project too far. It cannot be pushed back after it is fitted in the installing tool – but it can be pulled out.

- Fit the rewind spring counterclockwise in the tool.

- Secure the spring so that it cannot pop out.

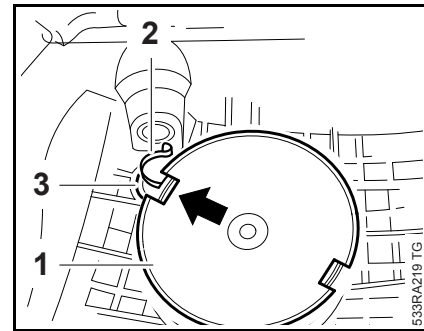

- Push the installing tool (1) with spring onto the starter post.

Line up the installing tool so that the anchor loop (2) is above the lug (3) and the opening in the installing tool is in the position shown (arrow).

- Use a suitable tool to engage the anchor loop (2) on the lug (3) – pull out the loop a little if necessary.

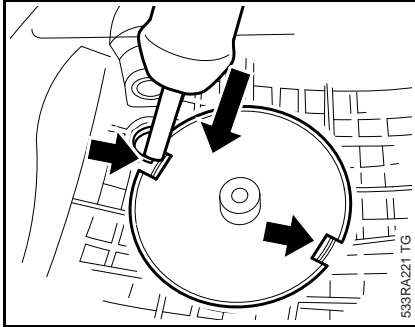

- Apply tool to openings (arrow) to push the spring into its seat in the fan housing.

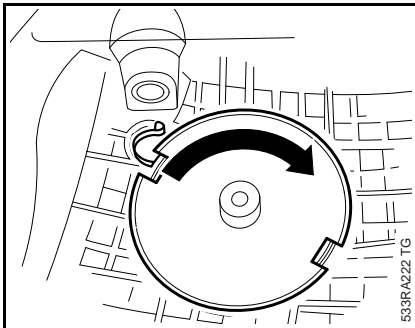

- Press the installing tool against the spring and rotate it slightly clockwise until the spring is properly seated.

- Remove the installing tool.

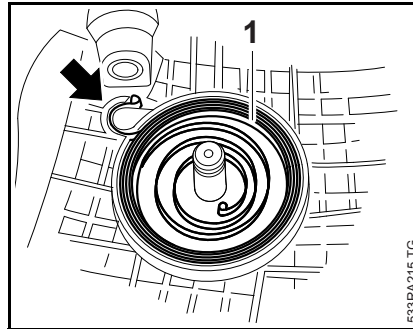

Check that the rewind spring (1) is properly seated and the anchor loop is engaged on the lug (arrow).

Machines with ErgoStart

The same procedures are used here as for the standard version. The differences are the anchor loop and the installed position of the spring.

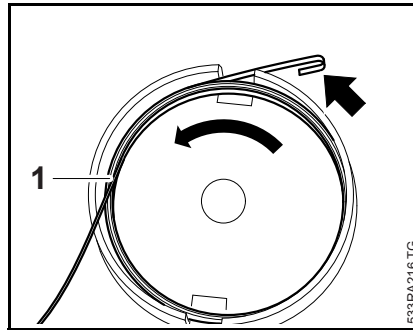

The open side of the anchor loop (arrow) must face inwards. Then fit the rewind spring (1) counter-clockwise.

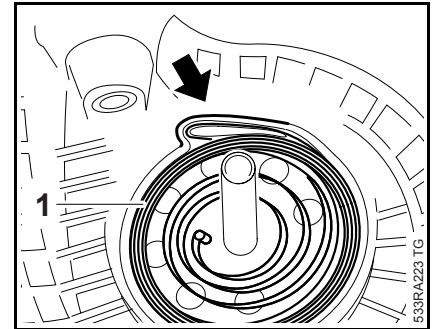

Check that the rewind spring (1) is properly seated and the anchor loop is engaged on the lug (arrow).

- Secure the spring so that it cannot pop out.
- Install the rope rotor, [10.5](#)
- Install the pawl(s), [10.3](#)
- Lubricate peg(s) on pawl(s) with grease, [16](#)
- Tension the rewind spring, [10.7](#)
- Reassemble all other parts in the reverse sequence.
- Tightening torques, [3.5](#)

11. Servicing the AV System

Vibration-damping springs are used for the connection between the handle frame and engine housing.

Damaged springs must always be replaced.

11.1 AV Spring on Oil Tank

The anti-vibration spring is located in the area of the oil tank and secured to the underside of the machine.

- Remove the chain sprocket cover, bar and chain,  5

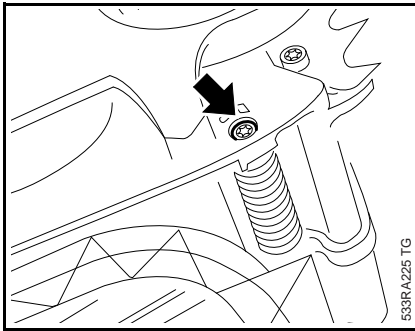

- Remove the screw (arrow).

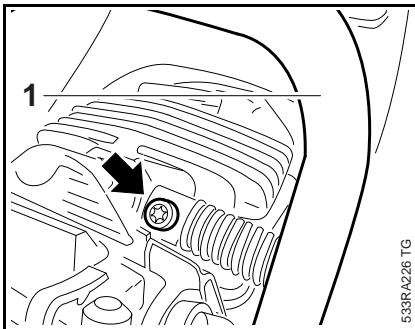

- Remove the shroud,  8.4
- Remove the screw (arrow).
- Lower the handle frame (1) a little.

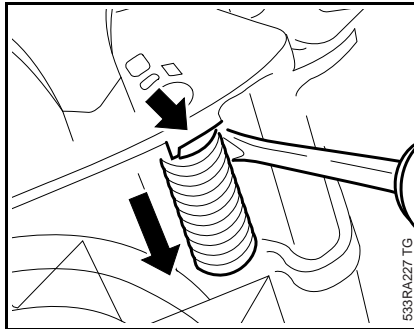

- Pry the anti-vibration spring out of its seat (arrow).
- Unscrew the anti-vibration spring from the handle frame.

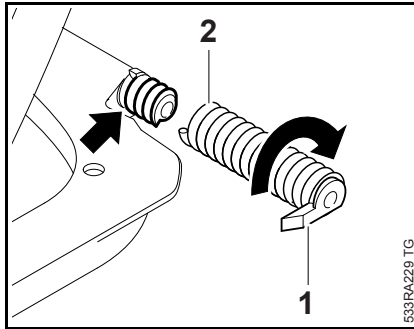

- Unscrew the bearing plug (1).
- Inspect the anti-vibration spring and plug and replace if necessary.
- Screw home the bearing plug (1) as far as stop.
- Screw the anti-vibration spring (2) into the handle frame (arrow) as far as stop.

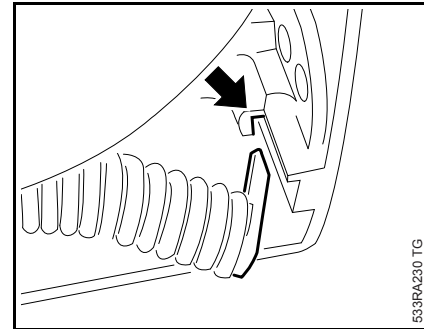

- Lift the handle frame a little and engage the tab (arrow) of the anti-vibration spring in the (arrow) in its seat.
- Fit screw in anti-vibration spring and tighten it down firmly.
- Position the anti-vibration spring on the cylinder, insert the screw and tighten it down firmly.
- Reassemble all other parts in the reverse sequence.
- Tightening torques,  3.5

11.2 AV Spring on Fuel Tank

The anti-vibration spring is located in the area of the fuel tank and secured to the underside of the machine.

- Remove the chain sprocket cover, bar and chain,  5

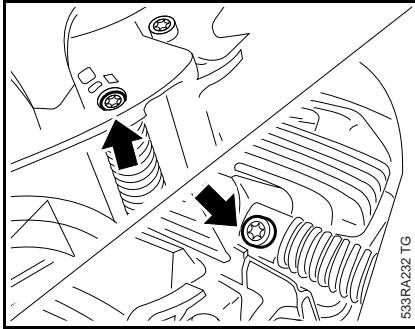

The handle frame can be loosened to simplify the following operations.

- Remove the shroud, 8.4
- Remove the screws (arrows) from the anti-vibration springs on the oil tank and cylinder.

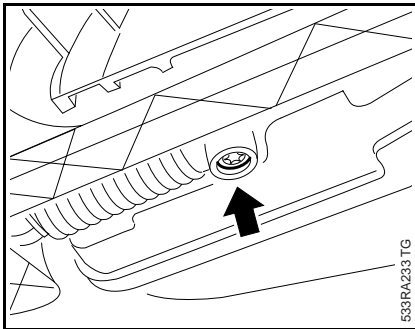

- Remove the screw (arrow).

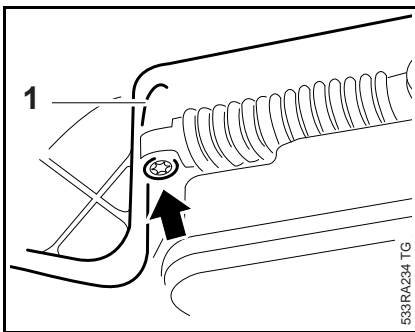

- Lower the handle frame (1) a little.
- Remove the screw (arrow).
- Take out the anti-vibration spring.

- Unscrew both bearing plugs from the anti-vibration spring.
- Inspect individual components and replace if necessary.
- Screw home the bearing plugs as far as stop.

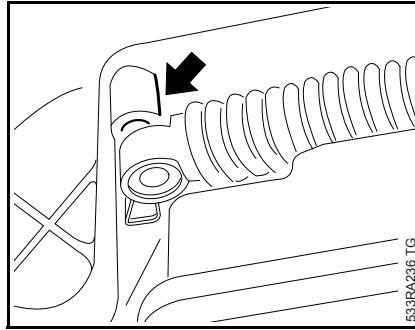

- Position anti-vibration spring in its seat (arrow) in the handle frames.
- Insert screw and tighten it down firmly.

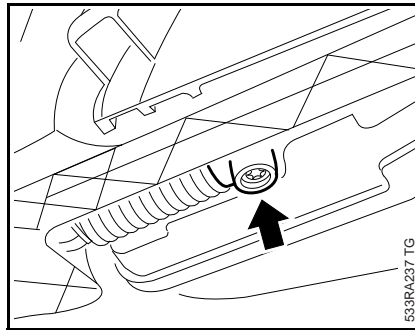

- Lift the handle frame a little and handle frame push the anti-vibration spring over the mount (arrow).
- Insert screw and tighten it down firmly.
- Reassemble all other parts in the reverse sequence.
- Tightening torques, 3.5

11.3 AV Spring on Cylinder

The anti-vibration spring is located between the handle frame and cylinder.

- Remove the chain sprocket cover, bar and chain, 5
- Remove the shroud, 8.4

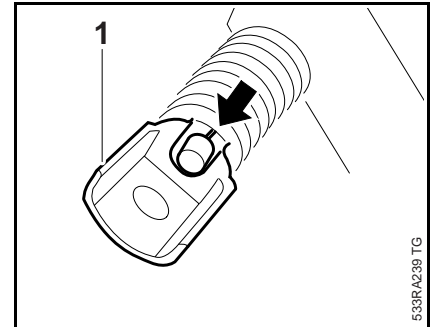

- Remove the screw from the cylinder.
- Disconnect the retainer (arrow) and unscrew the bearing plug (1).
- Unscrew the spring from the handle frame and pull out the retainer.

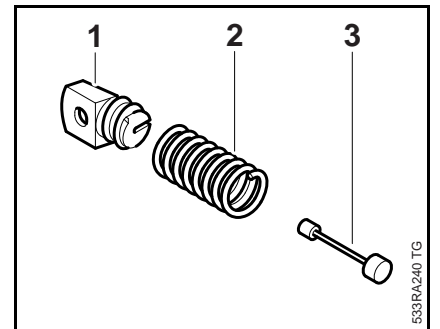

- Inspect the bearing plug (1), spring (2) and retainer (3) and replace if necessary.

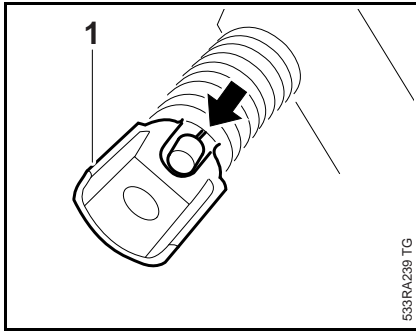

533RA239 TG

- Screw the spring onto peg on the handle frame as far as stop.
- Insert and attach the retainer (arrow) to the bearing plug (1).
- Screw bearing plug (1) into spring as far as stop.
- Install the handle frame, 11.4
- Reassemble all other parts in the reverse sequence.
- Tightening torques, 3.5

11.4 Handle Frame

- Remove the chain sprocket cover, bar and chain, 5
- Remove the shroud, 8.4
- Remove the filter base, 14.2
- Disconnect the throttle rod, 14.6

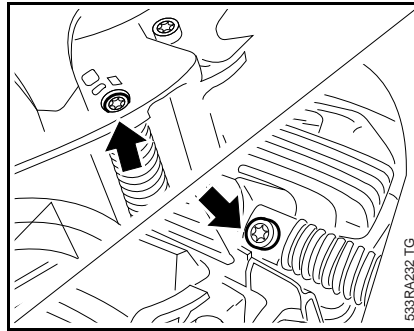

533RA232 TG

- Remove screws (arrows) from anti-vibration springs on oil tank and cylinder.

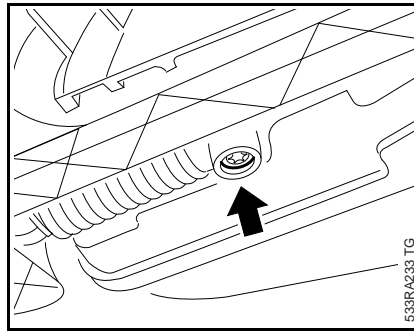

533RA233 TG

- Remove the screw (arrow).

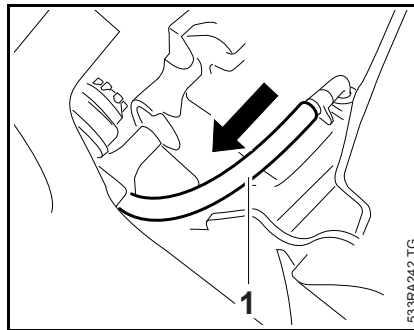

533RA242 TG

- Pry the anti-vibration springs out of their mounts.
- Pull tank vent hose (1) off the nipple.
- Hold the rear handle, turn the handle frame to the right and take it out.

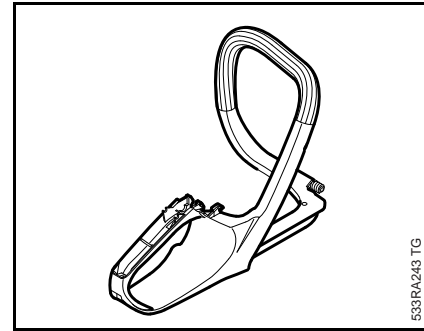

533RA243 TG

- Inspect the handle frame and replace if necessary.

If replacement is necessary, the anti-vibration springs, tank vent, handle molding and the Master Control lever have to be transferred to the new handle frame.

Always replace damaged parts.

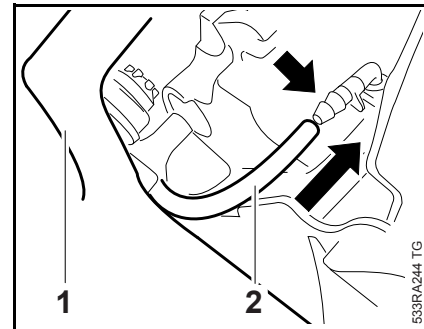

533RA244 TG

- Position the handle frame (1) on the engine housing.
- Push the tank vent hose (2) on to the nipple (arrow).

Do not use a tool for this job since it may damage the hose.

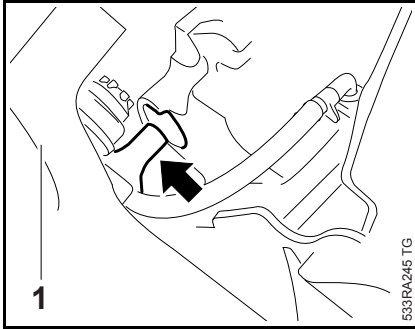

- Position the handle frame (1) so that the lug (arrow) lines up with the seat.
- Fit the anti-vibration springs on the cylinder and engine housing.

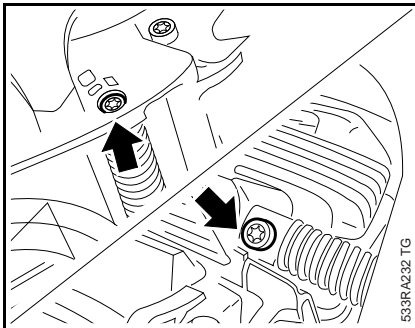

- Insert and firmly tighten down the screws (arrows) of the anti-vibration springs on the oil tank and cylinder.

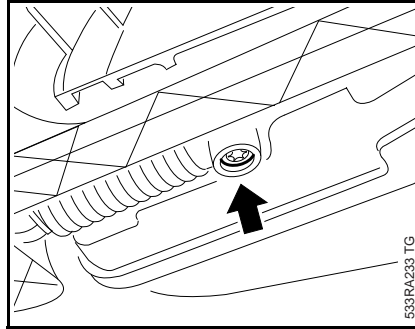

- Fit screw (arrow) and tighten it down firmly.
- Check that handle frame is properly seated.
- Reassemble all other parts in the reverse sequence.
- Tightening torques,  3.5

12. Master Control Lever

12.1 Switch Shaft

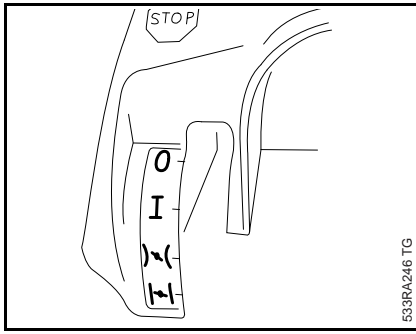

The following positions can be selected with the switch shaft:

- **0** = engine off
– ignition is switched off
- **I** = normal run position
– engine runs or may start in this position

To move the switch shaft from **I** to **|** or **|**, depress the interlock lever and throttle trigger at the same time.

- **|** = warm start
– warm engine is started in this position

The switch shaft returns to the run position when the throttle trigger is operated.

- **|** = cold start
– cold engine is started in this position

12.1.1 Removing and Installing

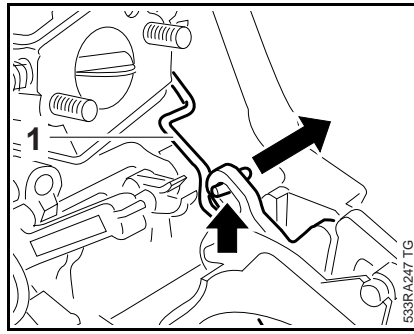

- Remove the filter base, 14.2
- Remove the handle molding, 12.2
- Disconnect the throttle rod (1) from the throttle trigger (arrow).
- Remove the carburetor, 14.3

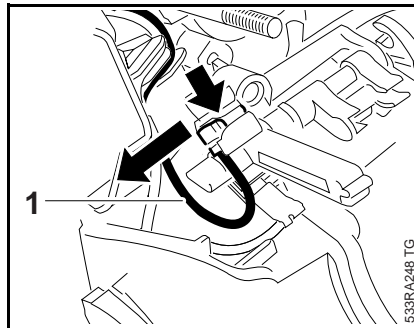

- Remove the connector (arrow) of short circuit wire (1).

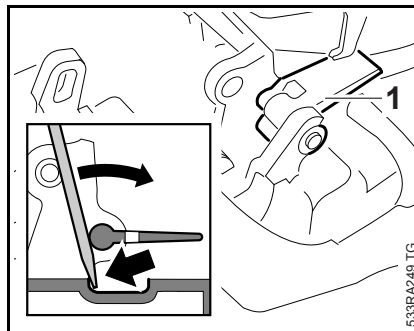

- Apply screwdriver to edge (arrow) and pry the lever (1) out of its seat.

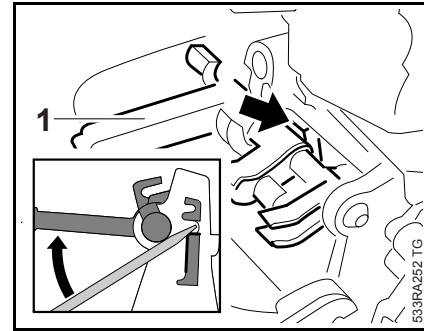

- Position a screwdriver on the ledge (arrow) below the switch shaft and pry the switch shaft (1) out of its mount.

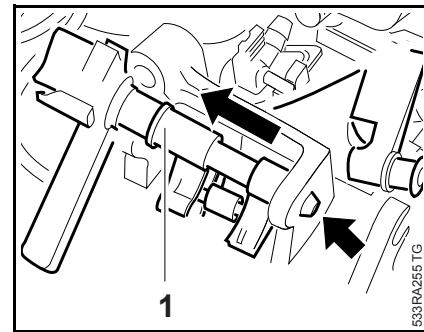

- Lift the switch shaft (1) a little and pull it out of the right-hand mount (arrow).

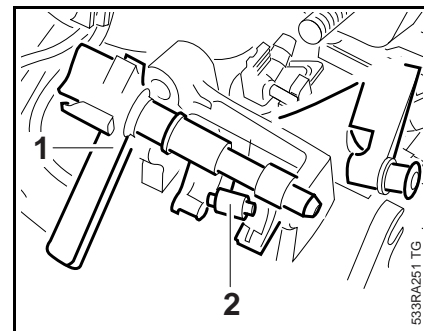

- Turn the switch shaft (1) a little and disconnect it from the lever (2).

- Remove the switch shaft and lever.

- Inspect the switch shaft and lever and replace if necessary.

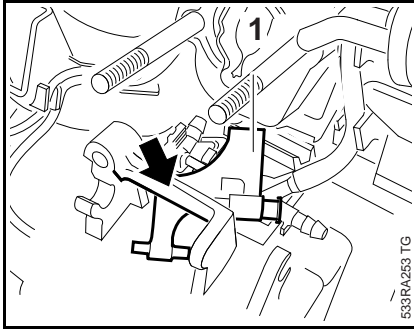

- Pass the lever (1) under the crossmember (arrow) and position it at an angle.

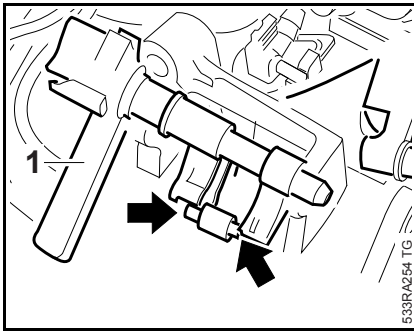

- Place the switch shaft (1) in position and engage it in the lever's pivot pins (arrows).

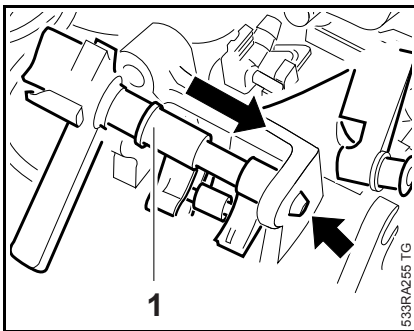

- Line up the switch shaft (1) and push it into the right-hand mount (arrow).
- Position the switch shaft and lever against the mounts.

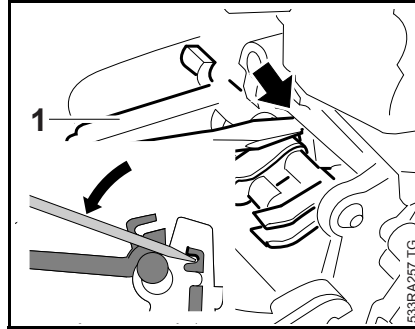

- Apply screwdriver to ledge (arrow) above the switch shaft (1).
- Ease the switch shaft (1) into the guide until it snaps into position.

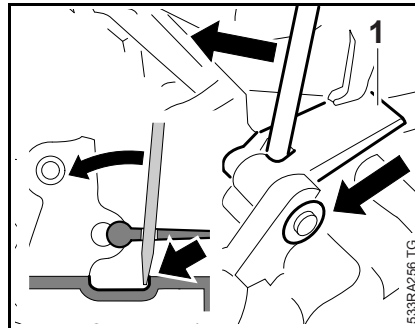

- Insert screwdriver through opening in the lever (1) and apply it to the edge (arrow).
- Push the lever (1) into the mounts until it snaps into position.

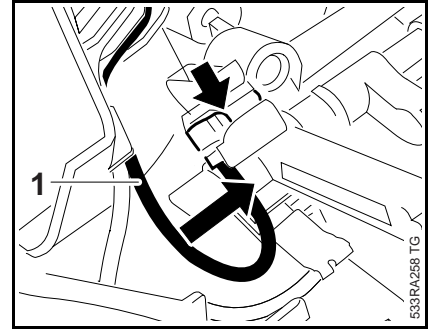

- Push connector of short circuit wire (1) into the receptacle on the switch shaft (arrow) as far as stop.

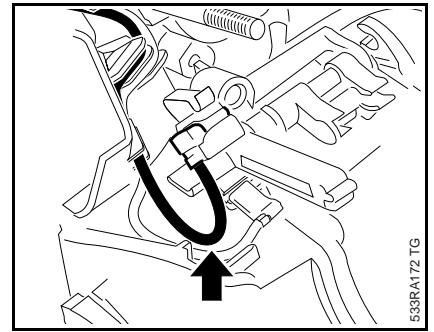

The short circuit wire must be looped (arrow) so that it can move with the switch shaft.

The wires must be laid close to the housing and properly seated in the guides.

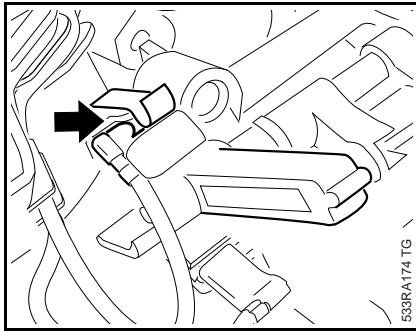

- Check operation
 - short circuit wire connector must touch the contact spring (arrow) in position “0”.
- Install the carburetor, 14.3
- Install the throttle rod, 14.6
- Install the handle molding, 12.2
- Reassemble all other parts in the reverse sequence.
- Tightening torques, 3.5

12.2 Throttle Trigger / Interlock Lever

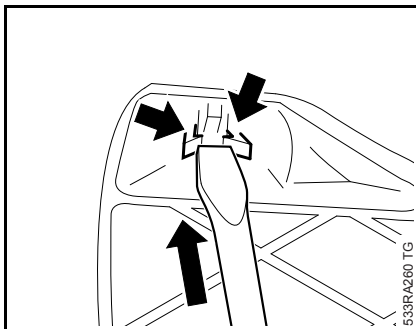

- Remove the filter base, 14.2
- Use a screwdriver to ease the lugs (arrows) apart and push them through the handle frame from below.

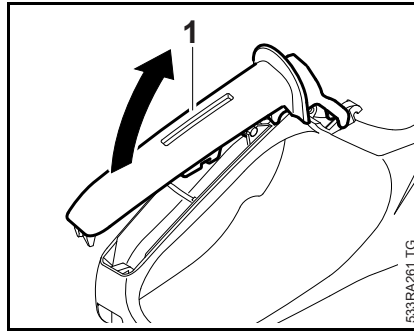

- Remove the handle molding (1).

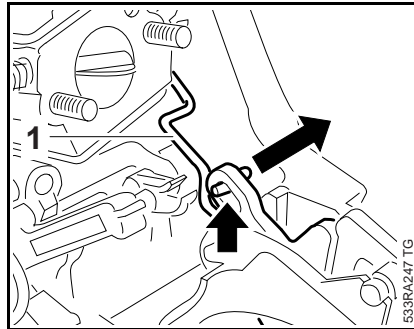

- Disconnect the throttle rod (1) from the throttle trigger (arrow).

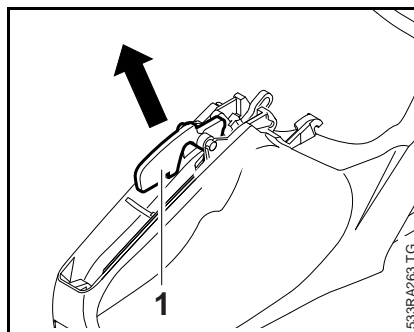

- Pry the interlock lever (1) out of its mounts and lift it away.

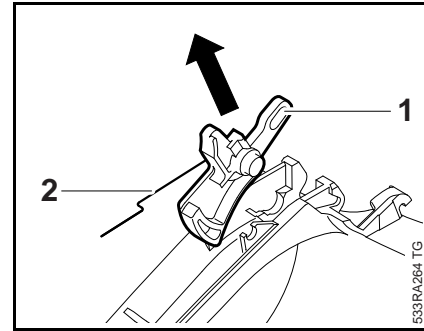

- Remove the throttle trigger (1) with torsion spring (2).
- Inspect the interlock lever, throttle trigger and torsion spring and replace if necessary.

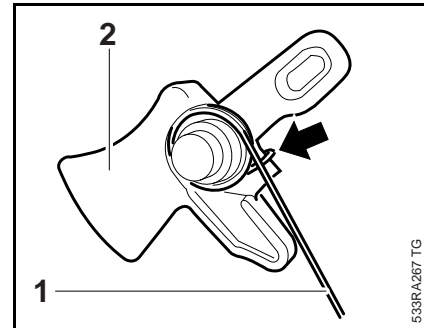

- Attach the torsion spring (1) to the throttle trigger (2)
 - note installed position (arrow).

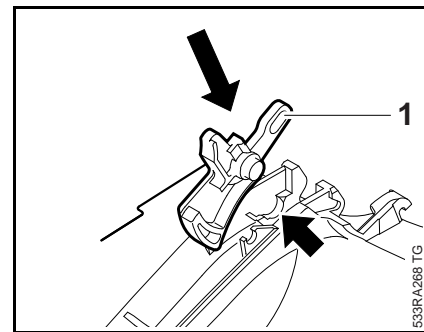

- Place throttle trigger (1) in mounts (arrow) in rear handle.

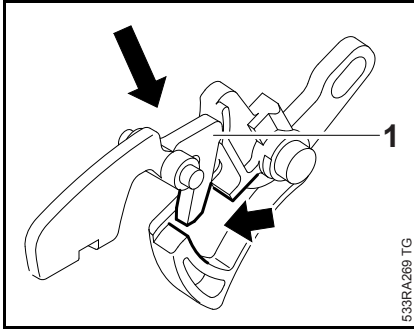

- When installing the interlock levers, make sure the stop (1) engages the guide (arrow).

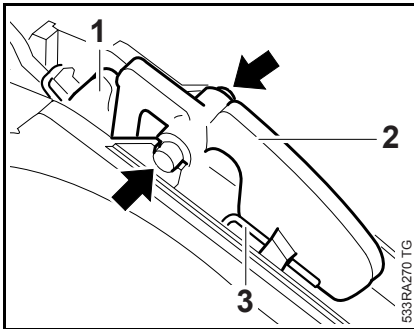

- Set throttle trigger to the full throttle position and hold it there.
- Attach interlock lever (2) to torsion spring (3) and push it into the guides (arrows) until it snaps into position.
- Depress the interlock lever until its stop (1) engages
 - this is the position required for mounting the handle molding.

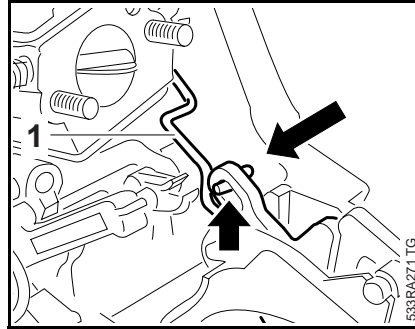

- Attach the throttle rod (1) to the throttle trigger (arrow).

Make sure the throttle rod is properly located in the mounts, 14.6

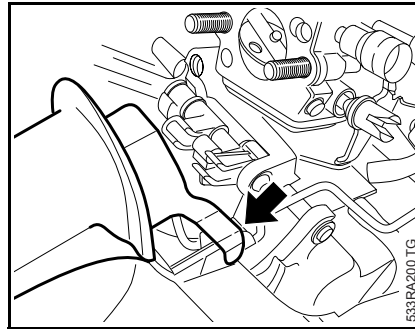

- Fit forked end (arrow) of handle molding (1) over the throttle rod mount.

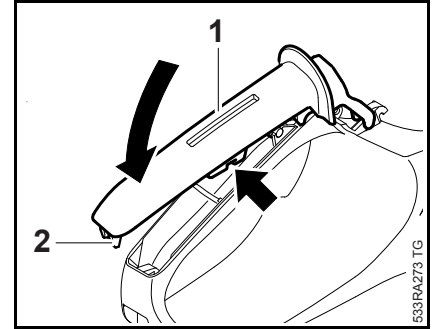



- Fit the handle molding (1) over the interlock lever (arrow), making sure the throttle rod remains attached to the throttle trigger – the handle molding secures the throttle rod in position.
- Push lugs (2) of handle molding (1) into opening until they snap into position.
- Check operation.
- Reassemble all other parts in the reverse sequence.
- Tightening torques, 3.5

13. Chain Lubrication

13.1 Pickup Body

Impurities gradually clog the fine pores of the filter with minute particles of dirt. This prevents the oil pump from supplying sufficient oil to the bar and chain. In the event of problems with the oil supply system, first check the oil tank and the pickup body. Clean the oil tank if necessary.

- Troubleshooting,  4.3
- Open the oil tank cap and drain the oil tank. Collect chain oil and dispose of it properly,  1.

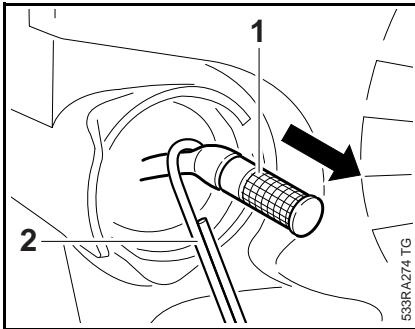



- Use hook (2) 5910 893 8800 to pull the pickup body (1) out of the oil tank.

Do not overstretch the suction hose.

- Pull off the pickup body (1), inspect it and replace if necessary.
- Install in the reverse sequence.

13.2 Oil Suction Hose

The oil suction hose is located on the underside of the machine and must be replaced if damaged.

- Open the oil tank cap and drain the oil tank. Collect chain oil and dispose of it properly,  1.
- Remove the handle frame,  11.4

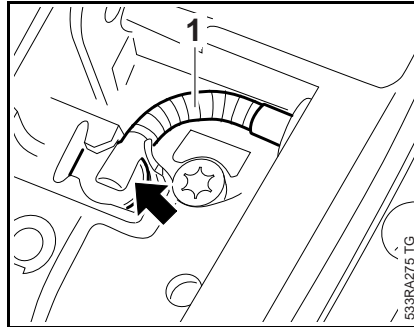

- Disconnect the oil suction hose (1) from the oil pump (arrow).

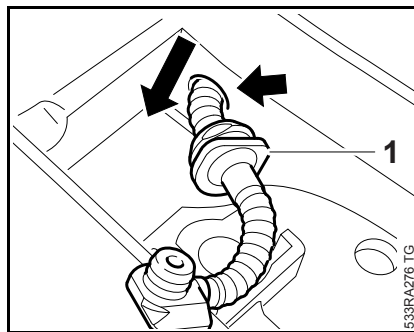

- Pry the oil suction hose (1) off the oil tank connector (arrow).
- Pull out the oil suction hose with pickup body, inspect it and replace if necessary.

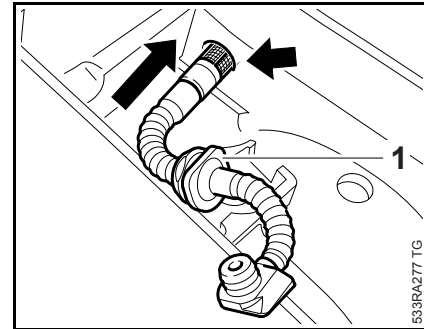

- Push the oil suction hose (1), pickup body first, through the housing bore (arrow).

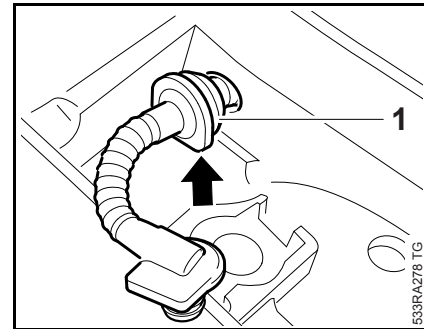

- Line up the oil suction hose (1)
 - the tab (arrow) must be against the guide.
- Press home the oil suction hose until the groove locates properly in the engine housing.

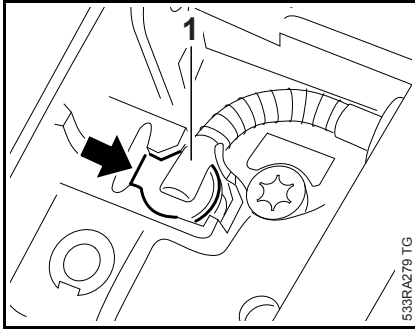

– Coat profile on oil suction connector with oil, 16

- Press home the oil suction hose (1) until the tab is completely flush with the guide (arrow) in the engine housing
 - oil suction hose is now secure.

– Check position of pickup body. If necessary, use hook 5910 893 8800 to position it properly.

The flange of the oil suction hose must locate flush against the engine housing.

– Reassemble all other parts in the reverse sequence.

– Tightening torques, 3.5

13.3 Removing and Installing the Oil Pump

The oil pump is press-fitted in the underside of the engine housing. A malfunction may be caused by the worm or the pump itself.

The worm is removed and installed at the clutch side, 8.3

– Remove the handle frame, 11.4

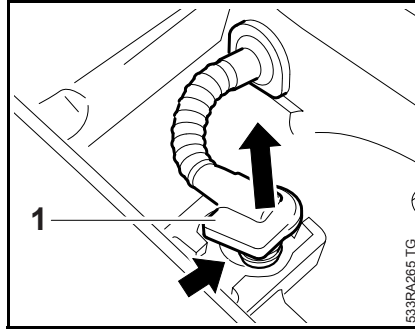

- Pry the oil suction hose (1) out of the oil pump (arrow).

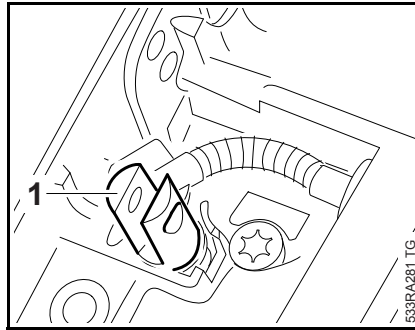

- Screw the puller (1) 1130 into the oil pump as far as stop.

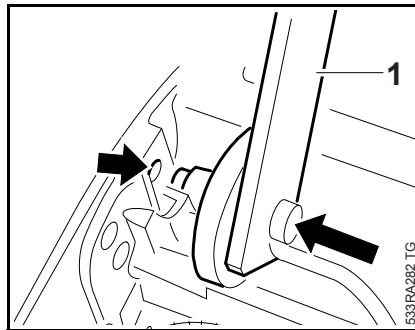

- Place the installing tool (1) 1123 890 2202 in position and push the pin into the bore (arrow).

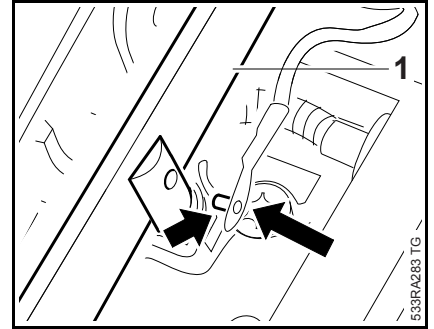

- Place the lever of the installing tool (1) in the puller and secure it with the pin (arrow).

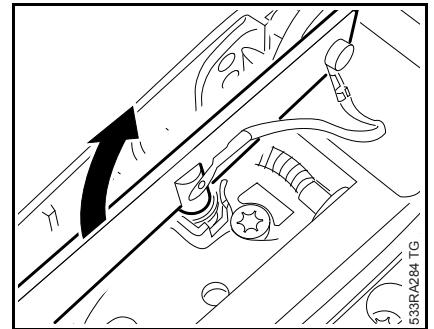

- Swing the lever upwards to pull the oil pump out of the engine housing.

– Unscrew the oil pump from the puller. Inspect it and replace if necessary.

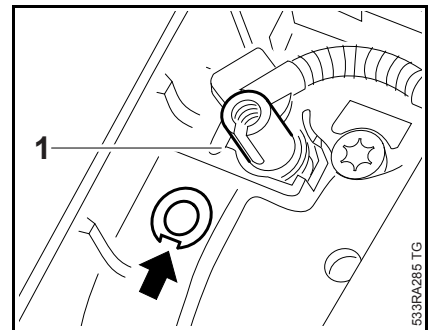

- Line up the oil pump (1) as shown by the symbol (arrow) – the countersunk bore must line up with the cross bore in the oil pump's seat.

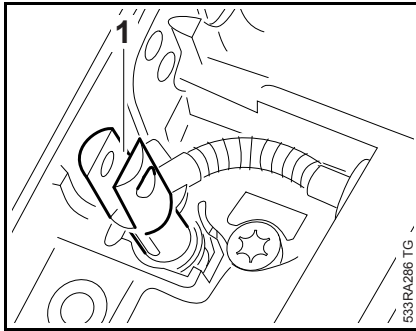

- Push the oil pump part way into the bore.
- Push smooth pin of installer (1) 1130 into the oil pump.

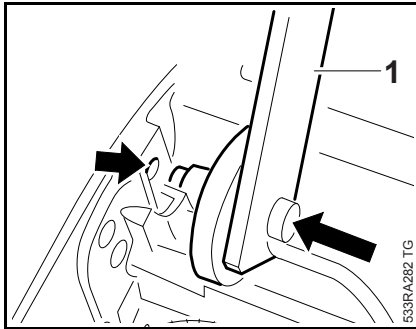

- Place the installing tool (1) 1123 890 2202 in position and push the pin into the bore (arrow).

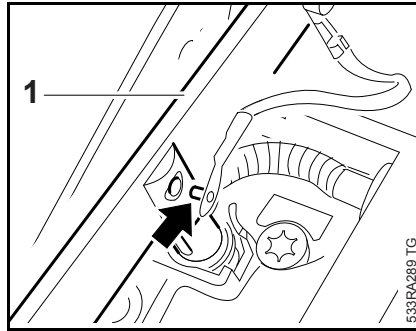

- Place the lever (1) of the installing tool in the installer and secure it with the pin (arrow).
- Use the lever (1) to press the oil pump into the bore as far as stop.
- Remove the installing tool and installer.

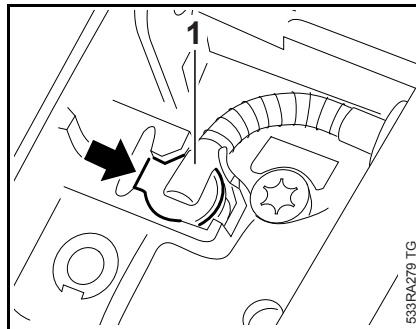

- Coat profile on oil suction hose connector with oil, [16](#)
- Push home the oil suction hose (1) until the tab is completely flush with the guide (arrow) in the engine housing, [13.2](#)
- If necessary, inspect the worm and replace it if necessary, [8.3](#)
- Install the handle frame, [11.4](#)
- Reassemble all other parts in the reverse sequence.
- Tightening torques, [3.5](#)

13.4 Valve

A valve is installed in the tank wall to keep internal tank pressure equal to atmospheric pressure. The valve must be replaced if it is very dirt or damaged.

- Remove the chain sprocket cover, bar and chain, [5](#)
- Open the oil tank cap and drain the oil tank. Collect chain oil and dispose of it properly, [1](#)

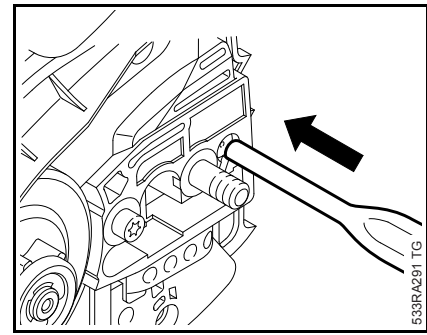

- Use a 6 mm drift to carefully drive the valve out of its seat in the housing and into the oil tank.

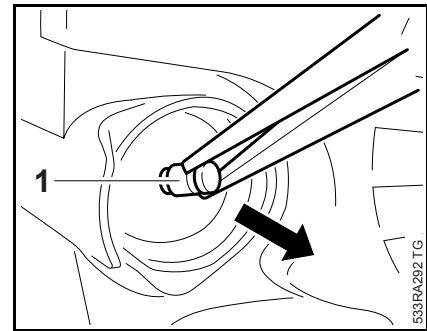

- Remove the old valve (1) from the oil tank.

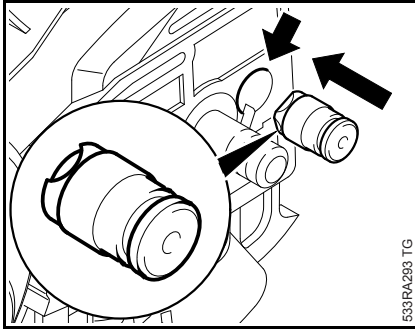

Check correct installed position.

- Insert the valve in the housing bore (arrow).

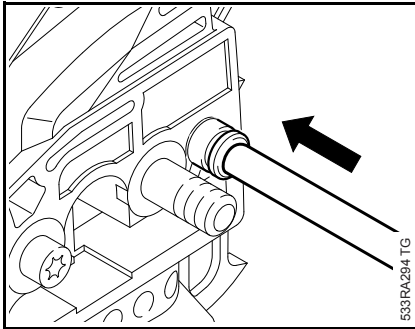

- Use a 6 mm drift to carefully drive in the new valve from outside – note installed depth.

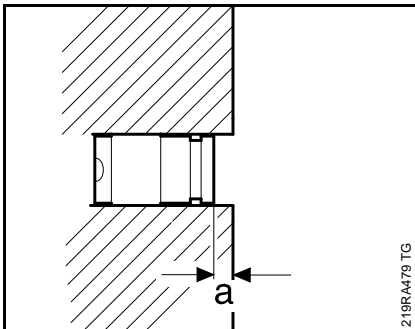

- Installed depth of valve:
a = about 2.5 mm
- Reassemble all other parts in the reverse sequence.

13.5 Oil Tank Cap

See instruction manual.

- Open the tank cap.

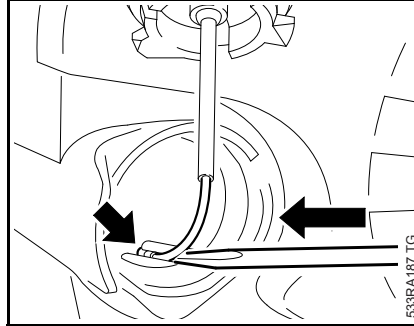

- Disconnect the nipple inside the tank (arrow).
- Inspect the tank cap and replace sealing ring or the cap.
- Install in the reverse sequence.
- Carry out leakage test.

14. Fuel System

When fitting or removing hoses in the fuel system:

Do not use pliers or any other sharp-edged tools since they may damage hoses.



Remove and install hoses by hand.

Use STIHL Press Fluid when fitting hoses,  16

14.1 Air Filter

Dirty air filters reduce engine power, increase fuel consumption and emissions and make starting more difficult.

The air filter should be checked when there is a noticeable loss of engine power.

- see also Troubleshooting,  4.6 or  4.7

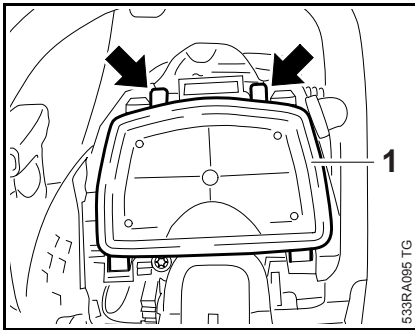

- Remove the shroud,  8.4
- Lift retaining tabs (arrows) a little and remove the air filter (1).
- Check the air filter and clean or replace if necessary
 - see instruction manual.
- Install in the reverse sequence.

14.2 Baffle / Filter Base

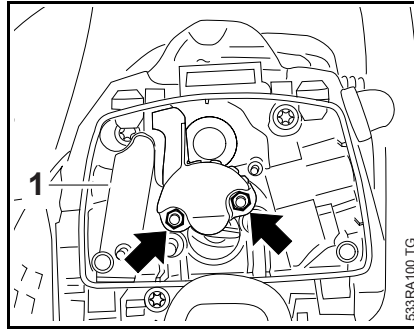

- Remove the air filter,  14.1
- Use screwdriver 5910 890 2420 to unscrew the nuts (arrows).
- Remove and inspect the baffle (1) and replace if necessary.

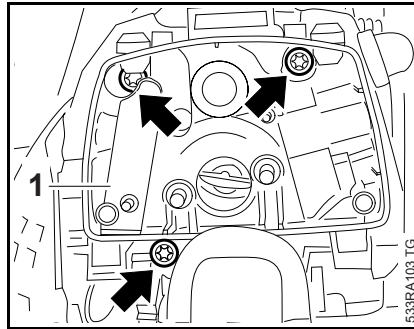

- Take out the screws (arrows).
- Remove and inspect the filter base (1) and replace if necessary.

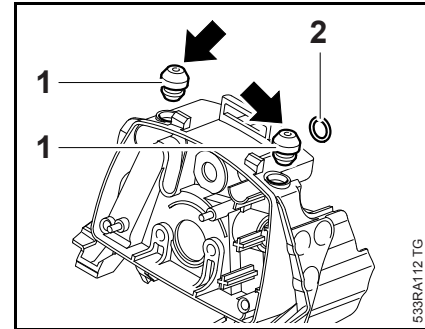

- Inspect the stop buffers (1) and replace if necessary – note correct position (arrows) when installing.
- Inspect the O-ring (2) and replace if necessary.
- Coat O-ring (2) with STIHL Press Fluid before installing,  16

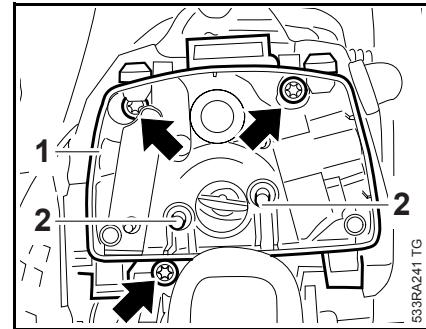

- Push the filter base (1) onto the studs (2).
- Fit the screws (arrows) and tighten them down firmly.

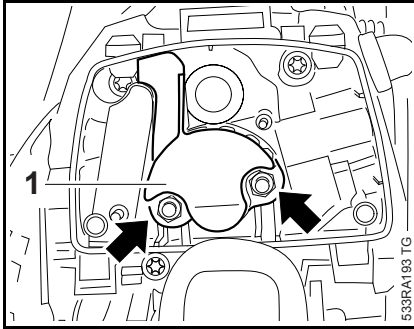

- Push the baffle (1) onto the studs and position it in the filter base.
- Fit the nuts (arrows) and tighten them down firmly.
- Reassemble all other parts in the reverse sequence.

Tightening torques, 3.5

14.3 Removing and Installing the Carburetor

- Remove the filter base, 14.2
 - Open the tap cap and drain the fuel tank. Collect fuel in a clean container.
- Remove the carburetor only when the tap can is open.
- Remove the handle molding if necessary, 12.2
 - Disconnect the choke rod, 14.6
 - Set Master Control lever to "0"

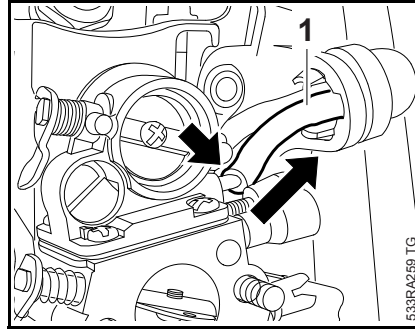

Machines with manual fuel pump

- Pull the fuel hose (1) off the stub (arrow).

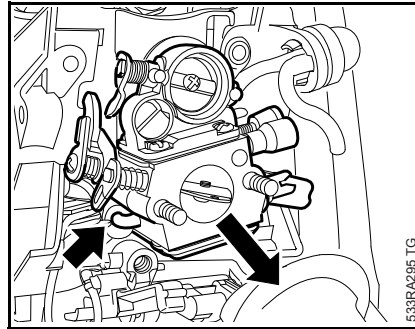

- Pull off the carburetor, and pull stub (arrow) out of fuel hose at the same time.
- Check the carburetor and repair or replace if necessary.

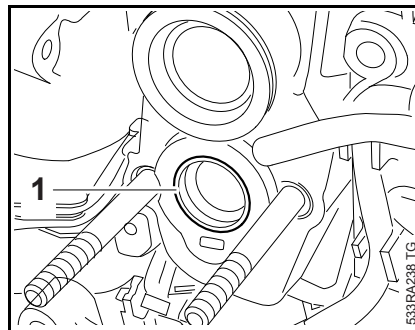

Sleeve (1) must be in place.

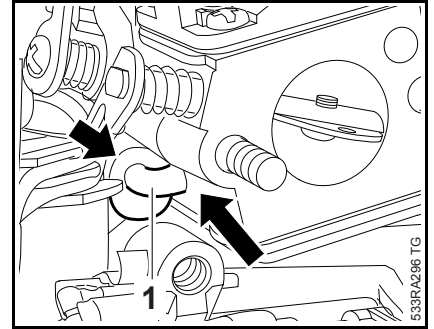

- Push the carburetor into position.
- When pushing the carburetor into position, check that the stub (1) is properly seated in the fuel hose (arrow).

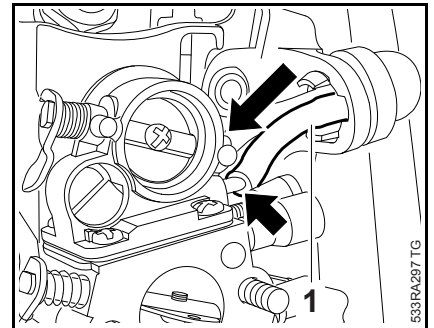

Machines with manual fuel pump

- Push the fuel hose (1) onto the stub (arrow).
- Attach the choke rod, 14.6
- Reassemble all other parts in the reverse sequence.
- Tightening torques, 3.5

14.3.1 Leakage Test

In the case of problems with the carburetor or fuel supply system, also check and clean or replace the tank vent,  14.8

The carburetor can be tested for leaks with the pump 0000 850 1300.

- Remove the carburetor,  14.3

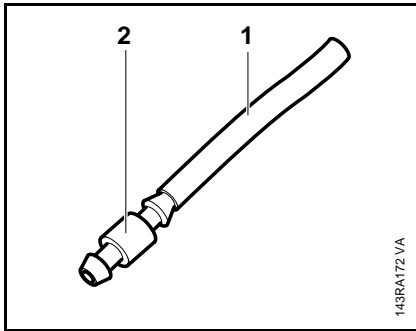

- Push the fuel line (1) 1110 141 8600 onto the nipple (2) 0000 855 9200.

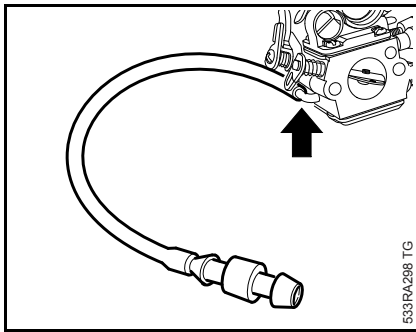

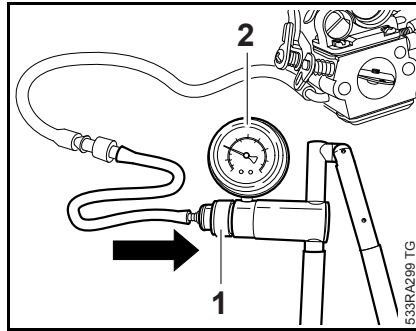

- Push the fuel line with nipple onto the carburetor's fuel stub (arrow).



- Push the pressure hose of pump 0000 850 1300 onto the nipple.

- Push the ring (1) to the right and pump air into the carburetor until the pressure gauge (2) indicates a pressure of about 0.8 bar (80 kPa).

If this pressure remains constant, the carburetor is airtight. However, if it drops, there are three possible causes:

1. The inlet needle is not sealing (foreign matter in valve seat or sealing cone of inlet needle is damaged or inlet control lever sticking), Remove to clean,  14.4.2
2. Metering diaphragm or gasket damaged, replace if necessary,  14.4.1
3. Pump diaphragm or gasket damaged, replace if necessary,  14.4.5

- After completing the test, push the ring (1) to the left to vent the system and then pull the fuel line off the carburetor.

- Install the carburetor,  14.3



- Reassemble all other parts in the reverse sequence.

- Tightening torques,  3.5

14.4 Servicing the Carburetor

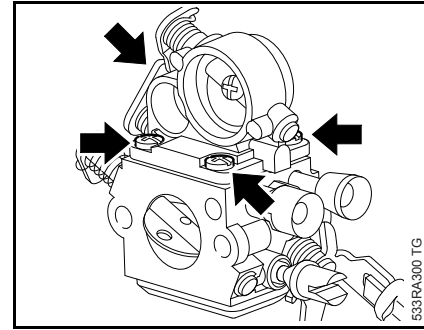
14.4.1 Metering Diaphragm



- Troubleshooting,  4.6
- Remove the carburetor,  14.3

- Take out the screws (arrows).

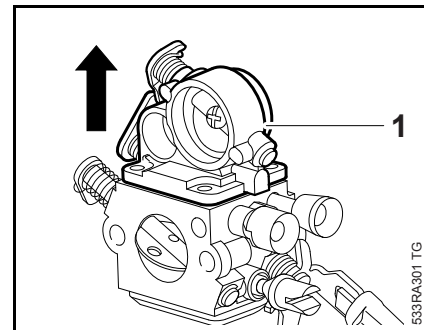

- Remove the end cover (1).

If the gasket and diaphragm are stuck to the carburetor, remove them very carefully..

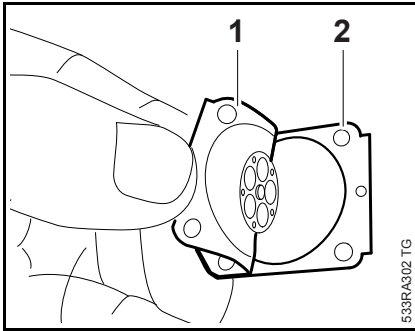

- Carefully separate the metering diaphragm (1) and gasket (2).

The diaphragm material is subjected to continuous alternating stresses and eventually shows signs of fatigue, i.e. the diaphragm distorts and swells and has to be replaced.

- Check the metering diaphragm for signs of damage and wear. Install a new gasket.

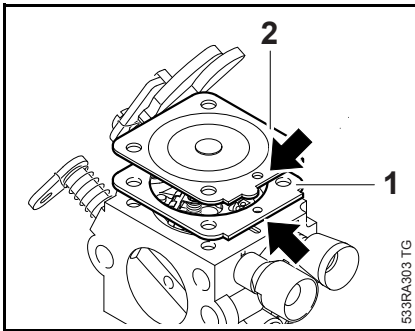

- Note installed positions of metering diaphragm (2) and gasket (1).
- Position the gasket (1) and metering diaphragm (2) so that the tabs (arrows) with holes point towards the adjusting screws.

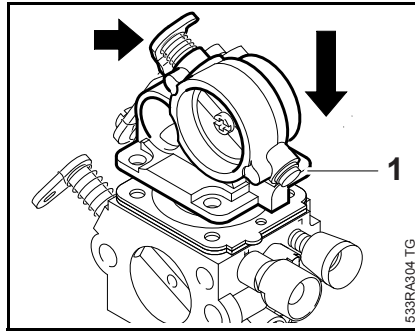

- Position the end cover (1) so that the lever (arrow) is opposite the adjusting screws.

- Fit the end cover (1) carefully – the holes must be in alignment.

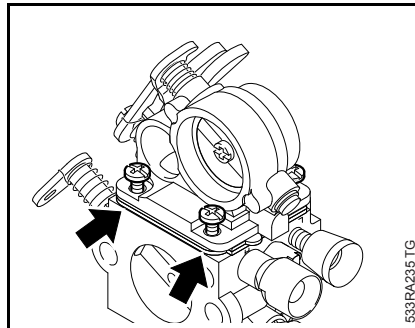

- Insert the screws but do not tighten yet.

- Check position of diaphragm and gasket.

The edge of the end cover must be in line with the edge of the carburetor body (arrows).

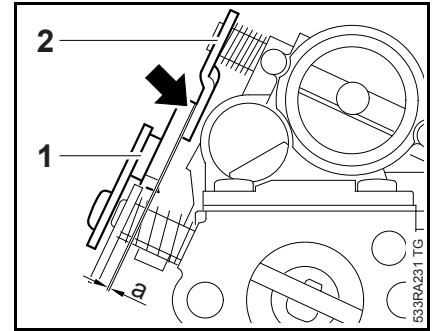

- The sides of the levers (1+2) must not touch each other (arrow).

Clearance "a" = about 0.3 mm

- Tighten down the screws in a crosswise pattern.

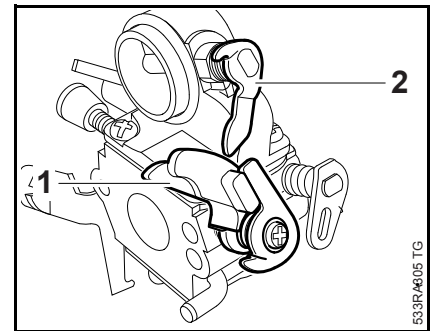

- Check operation: Throttle shaft lever (1) must engage the air valve's lever (2) – the clearance between the levers must remain constant.

- Reassemble all other parts in the reverse sequence.

- Tightening torques, 3.5

14.4.2 Inlet Needle

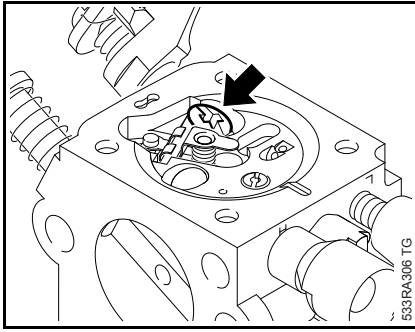

- Remove the metering diaphragm, [14.4.1](#)
- Take out the screw (arrow).

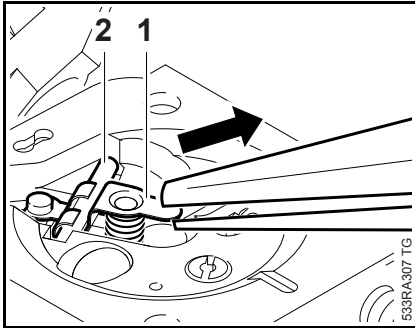

- Pull the inlet control lever (1) with spindle (2) out of the inlet needle's groove.

The small spring under the inlet control lever may pop out during disassembly.

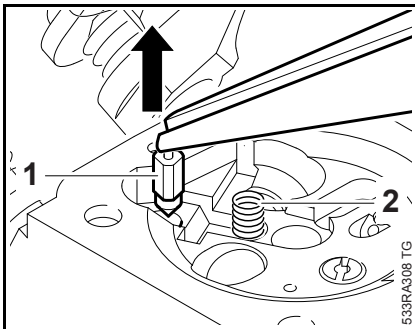

- Remove the inlet needle (1).

- Remove the spring (2). Inspect and replace if necessary.

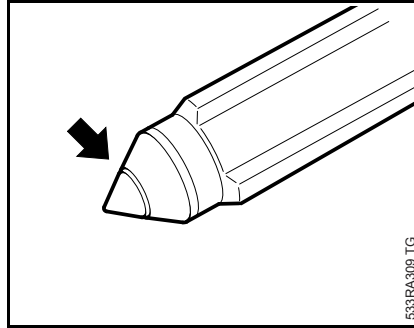

- If there is an annular indentation (arrow) on the sealing cone of the inlet needle, fit a new inlet needle.

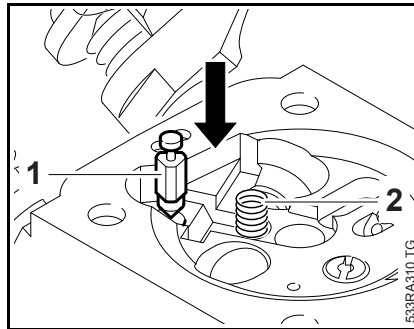

- Fit the inlet needle (1).
- Fit the spring (2) in the bore.

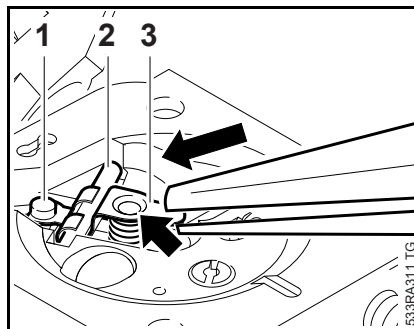

- Position the inlet control lever (3) with spindle (2) on the spring's seat (arrow) first, then slide the inlet control lever's clevis into the groove in the inlet needle (1).

Make sure the spring locates on the control lever's nipple.

- Press the inlet control lever down and secure it with the screw.
- Check that inlet control lever moves freely.
- Install the metering diaphragm, [14.4.1](#)
- Reassemble all other parts in the reverse sequence.

14.4.3 Fixed Jet

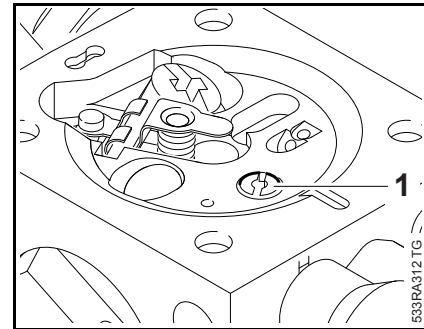

- Remove the metering diaphragm, [14.4.1](#)
- Use a suitable screwdriver to unscrew the fixed jet (1).
- Check the fixed jet and replace it if necessary.
- Install in the reverse sequence.

14.4.4 Valve Jet

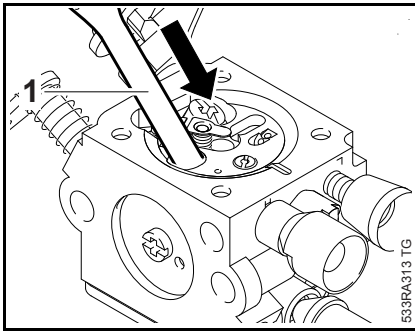

- Remove the metering diaphragm, 14.4.1
- Use a 5 mm drift (1) to drive out the valve jet in the direction of the choke tube.

Take care to position the drift exactly to ensure that valve jet and carburetor bore are not damaged.

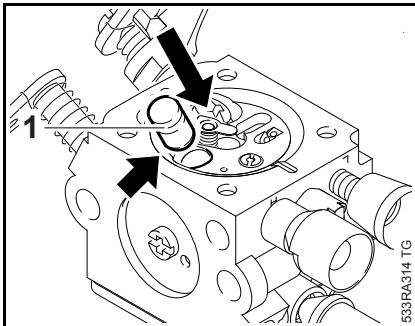

- Check the valve jet (1). If necessary, clean the carburetor bore and valve jet or install a new valve jet, 16
- Position the valve jet (1) so that the centering taper (arrow) points towards the carburetor bore.

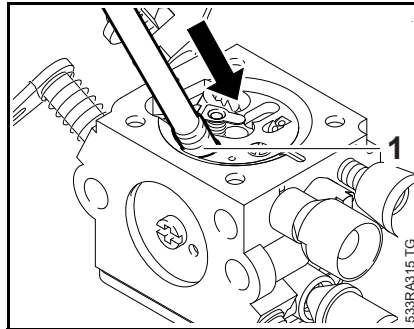

Take care to position the drift exactly to ensure that valve jet and carburetor bore are not damaged.

- Fit the valve jet (1) in the carburetor bore and press it home until it is flush with the edge of the carburetor bore.
- Reassemble all other parts in the reverse sequence.

14.4.5 Pump Diaphragm

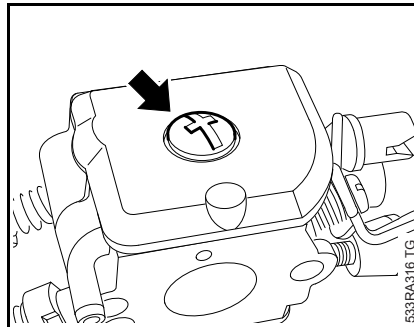

- Remove the carburetor, 14.3
- Remove the screw (arrow).

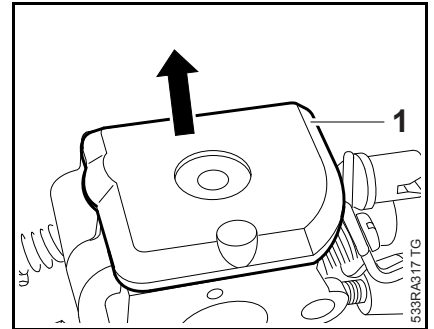

- Carefully remove the end cover (1).

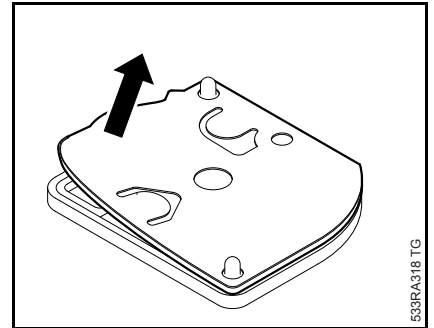

- Carefully remove the gasket with pump diaphragm from the end cover.

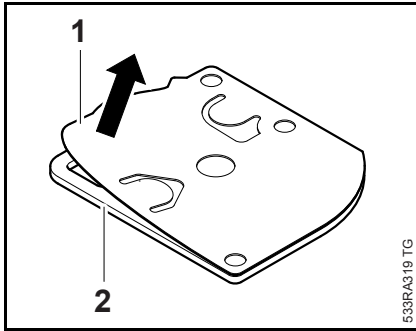

- Carefully separate the pump diaphragm (1) and gasket (2).

The diaphragm material is subjected to continuous alternating stresses and eventually shows signs of fatigue, i.e. the diaphragm distorts and swells and has to be replaced.

- Check the pump diaphragm for signs of damage and wear. Install a new gasket.
- Check fuel strainer for contamination and damage. Clean or replace if necessary,  16

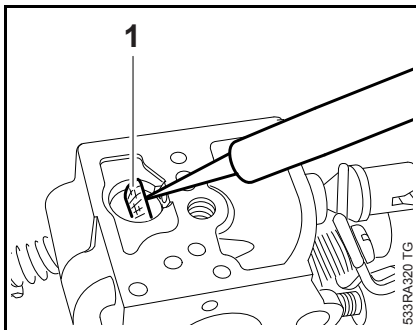

- Use a needle to remove the fuel strainer (1) from the carburetor body.

- Install in the reverse sequence.

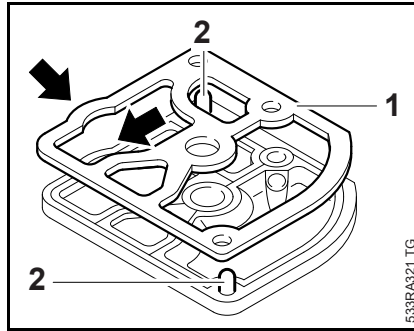

- Fit the gasket (1) so that it matches the contour of the end cover (arrows) and is held in position by the pegs (2).

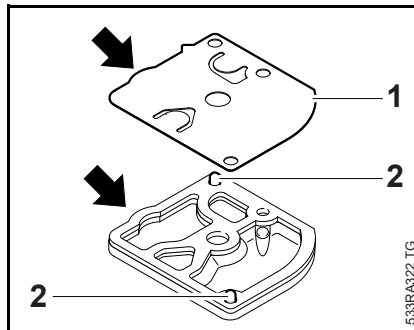

- Coat the diaphragm (1) with fuel and fit it so that it matches the contour of the gasket (arrows) and is held in position by the pegs (2).

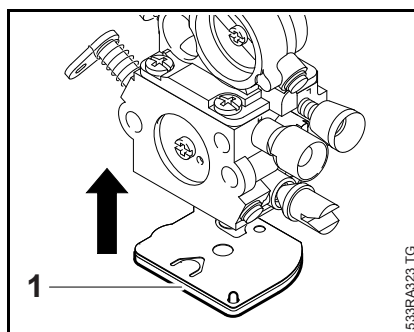

- Line up the end cover (1) so that the shoulder (arrow) points towards the throttle shutter.

- Place the end cover (1) against the carburetor body from below so that the gasket and pump diaphragm remain in position on the end cover.

- Align the end cover (1) so that its pegs engage the holes in the carburetor body.

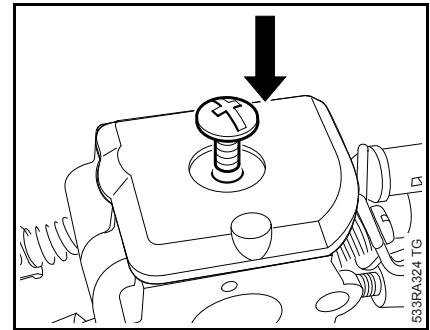



- Check that diaphragm and gasket are properly seated.

- Insert screw and tighten it down firmly.

- Reassemble all other parts in the reverse sequence.



14.4.6 Air Valve

Air valve shaft stiff or air valve cannot be closed or opened properly:

- Remove the carburetor,  14.3
- Carburetor troubleshooting,  4.6

Checking position of throttle shutter (position of throttle trigger)/air valve

The correct position of the air valve can be checked visually as follows:

- Throttle shutter in idle position
 - air valve completely closed.
- Throttle shutter between idle position and full throttle – air valve between closed and wide open¹⁾
- Throttle shutter in full throttle position – air valve wide open¹⁾
- Throttle shutter during cold start in  position
 - air valve completely closed
- Throttle shutter during warm start in  position – air valve open about 10°

1) It must be possible to move the air valve in both directions and it must always return to its starting position

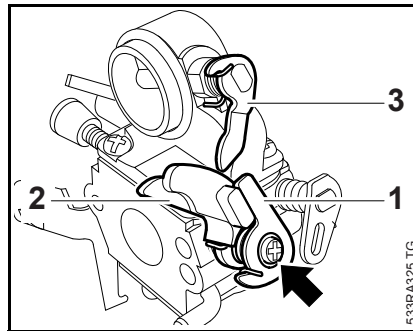

Lever (1) must butt against lever (2) and engage lever (3).

Screw (arrow) must be tightened down firmly.

The edge of the end cover must be in line with the edge of the carburetor body.

The side of the levers (2+3) must not touch each other. Clearance "a" = about 0.3 mm,  14.4.1

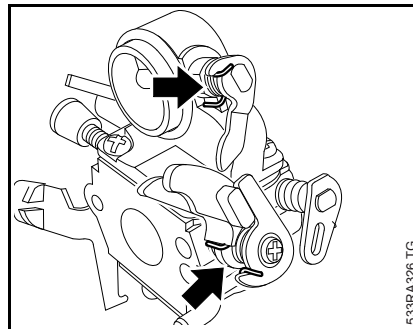

The torsion springs (arrows) be preloaded when attached to the levers.

Removing and Installing

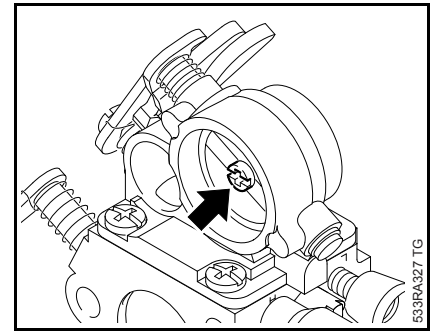

- Remove the screw (arrow).

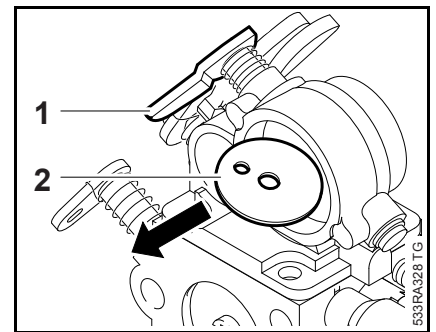

- Turn the air valve shaft (1) and pull out the air valve (2).

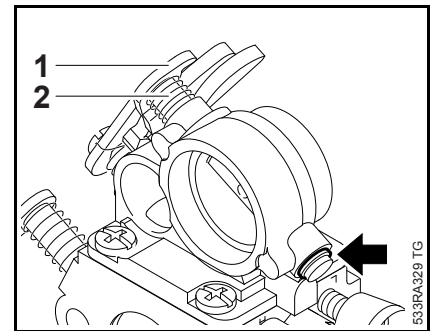

- Remove the E-clip (arrow).
- Pull out the air valve shaft (1) and disconnect and relax the torsion spring (2) at the same time.
- Clean the air valve shaft and guides,  16

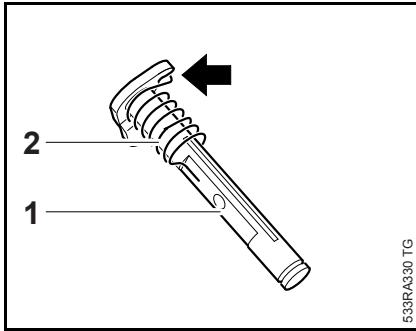

- Check the air valve shaft (1) and torsion spring (2) and replace if necessary.
- Note installed position (arrow) of torsion spring.

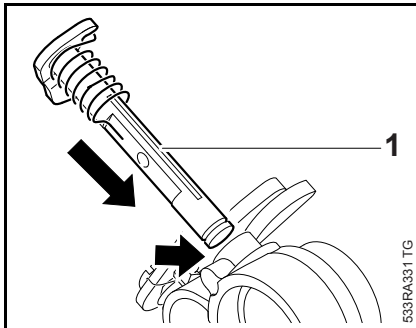

- Push the air valve shaft (1) into the valve body (arrow).
- Apply thin coating of oil to air valve shaft and guides, [16](#)

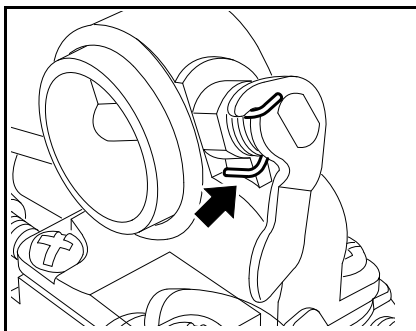

- Position leg of torsion spring against web (arrow) on valve body.

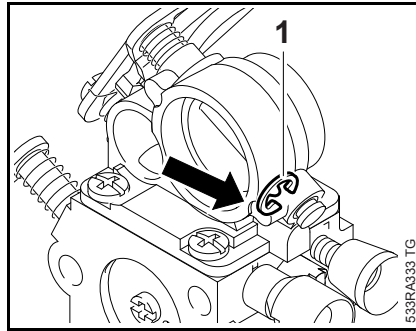

- Fit the E-clip (1).

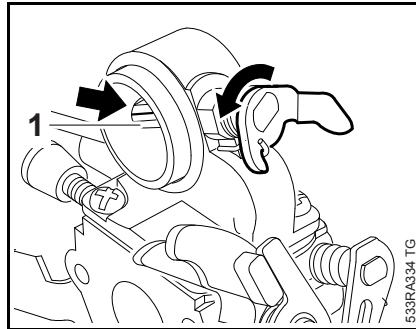

- Turn the air valve shaft (1) counterclockwise until its flat side (arrow) points upwards – air valve shaft is now preloaded.

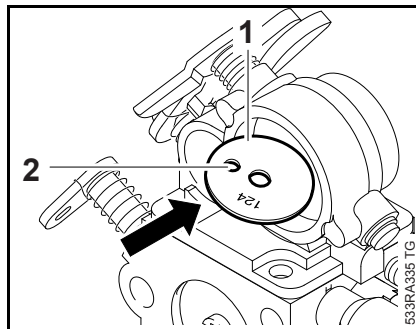

- Hold the air valve shaft in the preloaded position.
- Slide the air valve (1), with the hole (2) on the left and the marking visible, into the slot in the shaft.

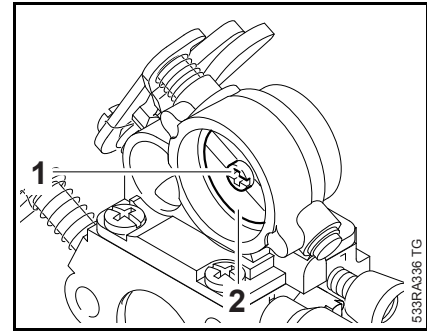

- Coat the screw with thread-locking adhesive, [16](#)
- Insert new screw (1) and tighten moderately.
- Close the air valve (2) and center it in the valve body's bore.
- Tighten down the screw firmly.
- Check valve's freedom of movement.
- Reassemble all other parts in the reverse sequence.

14.4.7 Choke Shaft / Choke Shutter

Choke shaft stiff or choke shutter cannot be closed or opened properly:

- Remove the carburetor, [14.3](#)
- Carburetor troubleshooting, [4.6](#)

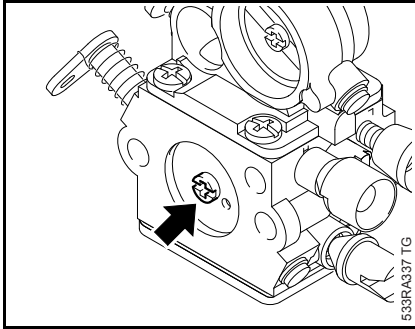

- Turn the choke shaft until the choke shutter is closed.
- Remove the screw (arrow).

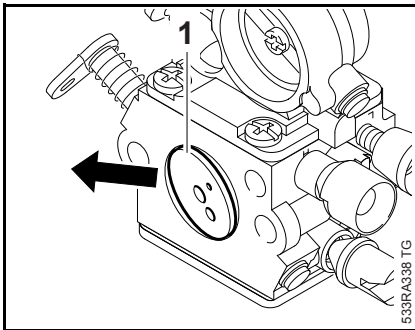

- Turn the choke shaft a little and take out the shutter (1).

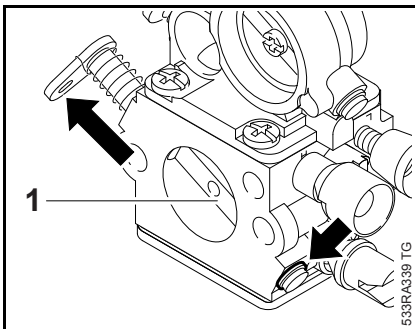

- Remove the E-clip (arrow).
- Pull out the choke shaft (1) in the direction of the lever. Disconnect and relax the torsion spring at the same time.

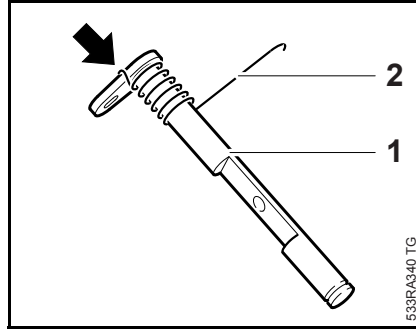

- Check the choke shaft (1) and torsion spring (2) and replace if necessary.
- Note installed position (arrow) of torsion spring (2).
- Clean the choke shaft and guides,  16
- Install in the reverse sequence.

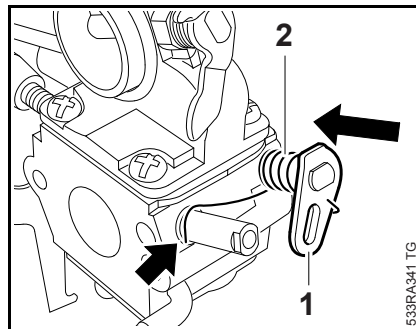

- The throttle shaft is shown without the lever for reasons of clarity.
- Push the choke shaft (1) into the carburetor.
 - Position the torsion spring (2) on the throttle shaft (arrow).

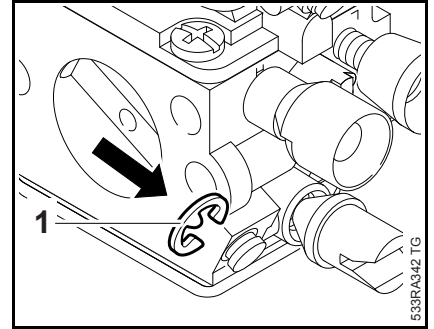

- Fit the E-clip (arrow) and let go of the choke shaft.

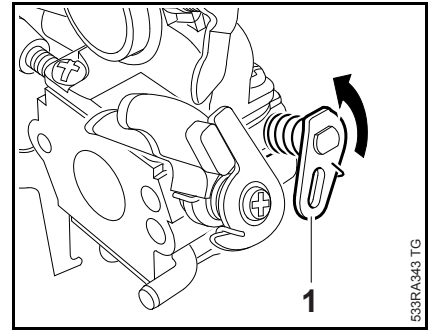

- Turn the choke shaft (1) counter-clockwise until its flat side faces forwards – choke shaft is now preloaded.

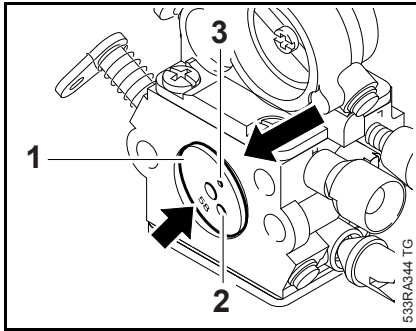

– Hold the choke shaft in the preloaded position.

- Position the choke shutter (1) in the carburetor bore so that the large hole (2) is on the right and the small hole (3) is at the top – the marking (arrow) must be visible below the choke shaft.

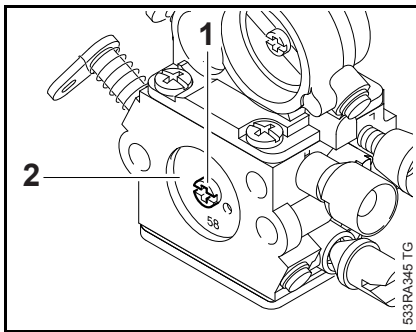

– Coat screw with threadlocking adhesive, 16

- Fit new screw (1) and tighten it moderately.
- Close the choke shutter (2) and center it in the carburetor body's bore.
- Tighten down the screw firmly.
- Check freedom of movement.
- Reassemble all other parts in the reverse sequence.

14.4.8 Throttle Shaft / Throttle Shutter

Throttle shaft is stiff or throttle shutter cannot be closed or opened properly:

- Remove the carburetor, 14.3
- Carburetor troubleshooting, 4.6

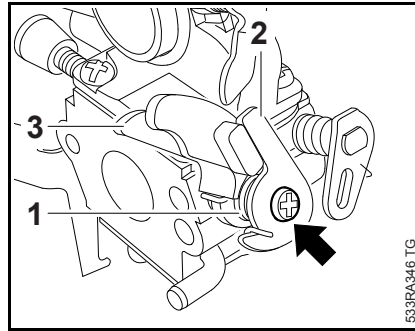

- Remove the screw (arrow).

- Relieve tension of torsion spring (1) and remove the lever (2).
- Pull off the torsion spring (1) and lever (3).

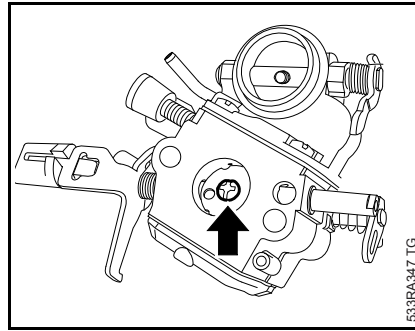

- Remove the screw (arrow).

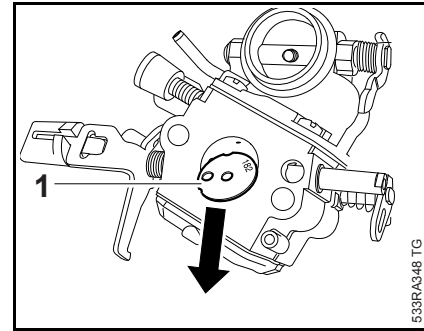

- Turn the throttle shaft a little and pull out the throttle shutter (1).

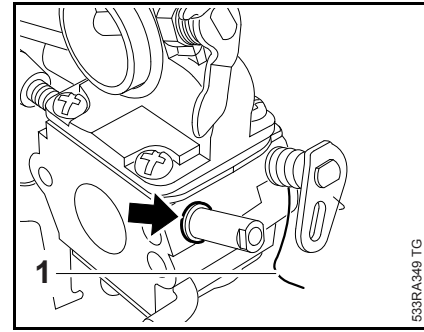

- Remove the torsion spring (1).
- Remove the E-clip (arrow).

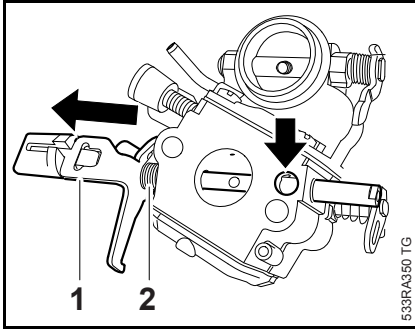

- Pull out the throttle shaft (1) in the direction of the adjusting screws. Disconnect and relax the torsion spring (2) at the same time.
- Plug the bore (arrow) to prevent the pump piston popping out.
- Clean the throttle shaft and guides, 16

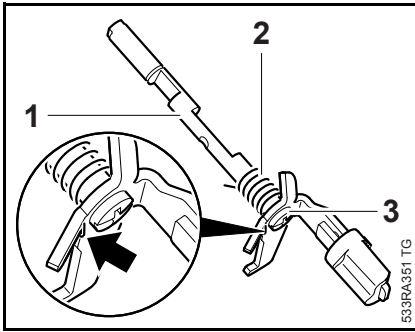

- Check the throttle shaft (1) and torsion spring (2) and replace if necessary.
- Note installed position (arrow) of torsion spring.

The screw (3) must not be loosened – it guarantees the factory-set position of the lever.

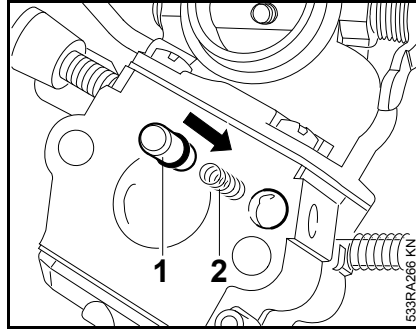

- Remove the pump piston (1) and spring (2), check the parts and replace pump piston kit if necessary.
- First fit the spring (2) and then the pump piston (1) in the bore (arrow).

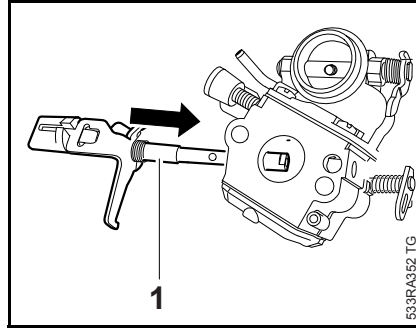

- Push the throttle shaft (1) with torsion spring into the carburetor body from the side with the adjusting screws.

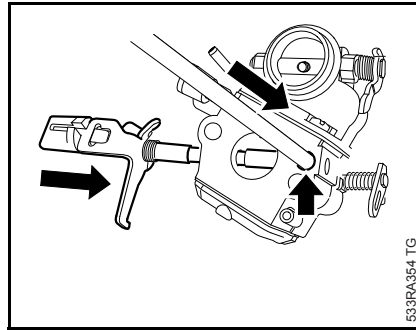

- Use a suitable tool to press the accelerator pump piston into the bore (arrow) and then push the throttle shaft all the way through.

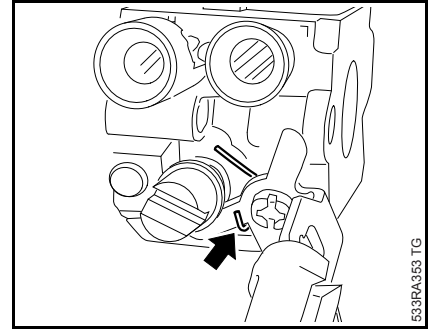

- Position torsion spring on carburetor body's shoulder (arrow).

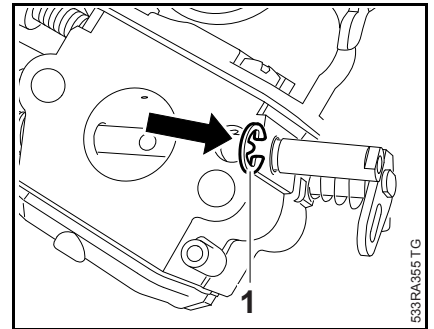

- Fit the E-clip (1).

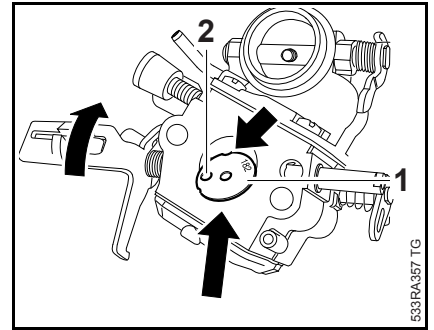

- Turn the throttle shaft (1) counter-clockwise until its flat side is visible.
- Hold the throttle shaft in the preloaded position.
- Place the throttle shutter (1), notch (arrow) first and the hole (2) on the left, on the flat side of the shaft – the marking must be visible.

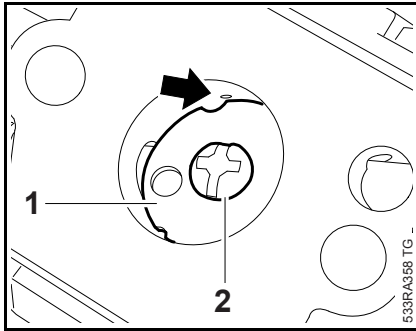

– Coat screw with threadlocking adhesive, 16

- Fit new screw (2) and tighten it moderately.
- Close the throttle shutter (1) and center it in the carburetor body's bore.

The notch (arrow) in the throttle shutter must line up with the small hole in the carburetor body.

- Tighten down the screw firmly.
- Check freedom of movement.

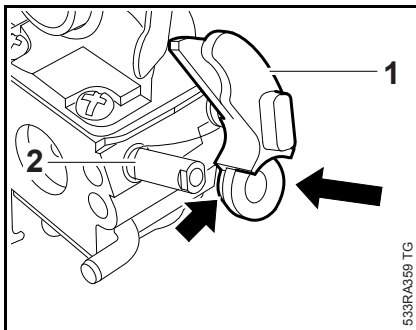

- Lift the leg (2) of the torsion spring.
- Push the lever (1), shoulder (arrow) first, onto the throttle shaft.

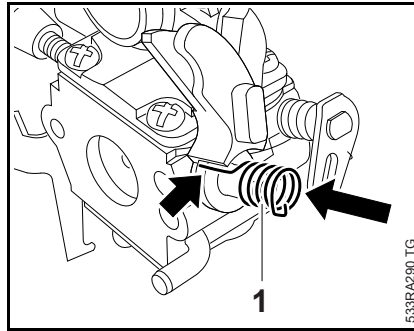

- Fit the torsion spring (1) so that its leg locates on the lever (arrow).

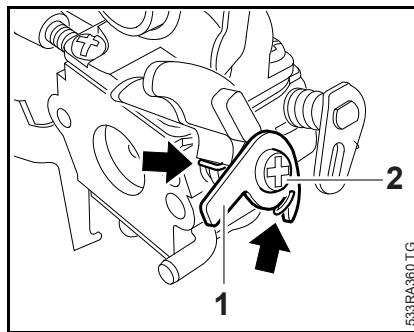

- Attach the torsion spring to the lever (arrow).
- Fit the lever (1) and tighten the screw (2) slightly – it must still be possible to turn the lever.

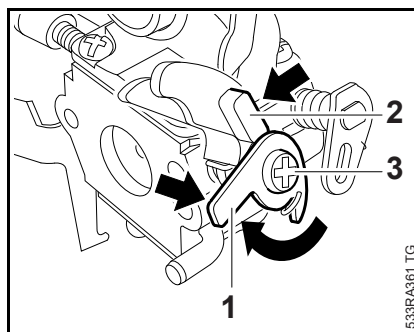

- Turn the lever (1) clockwise until its arm can be fitted against the stop (arrows) and the lever (1) engages the two flats on the throttle shaft.

- Hold lever (2) steady during this process.

- Tighten the screw (3) a little further – it must be possible to lift lever (2) far enough for lever (1) to be moved past it.

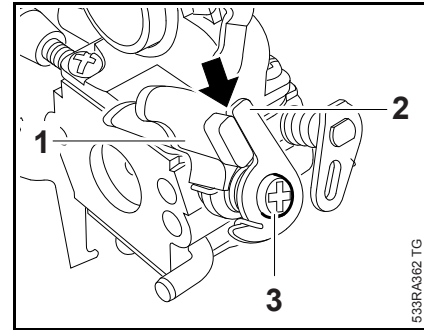

- Hold lever (1) and lever (2) together on the stop (arrow).
- Tighten down the screw (3) firmly.

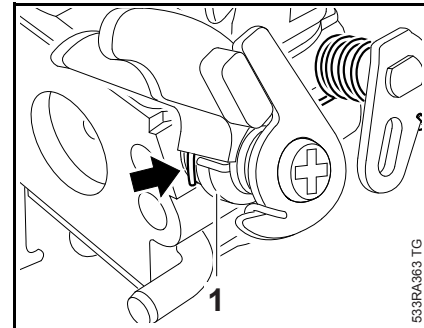

- The torsion spring on the choke shaft must locate on the shoulder (arrow) of lever (1).

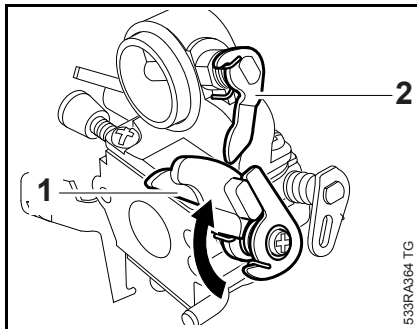

- Check operation:
Lever (1) must engage the air valve's lever (2) when the throttle shaft is turned.

The edge of the end cover must line up with the edge of the carburetor body.

The sides of the levers (1+2) must not touch each other.
Clearance "a" = about 0.3 mm,
📖 14.4.1

- Reassemble all other parts in the reverse sequence.

14.4.9 Adjusting Screws

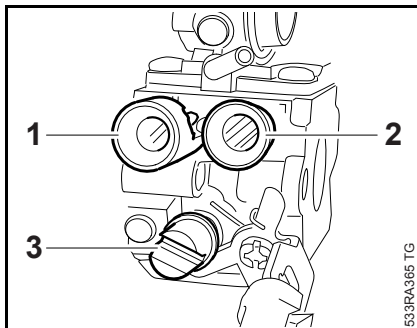

There are three adjusting screws on the carburetor:

- H** = high speed screw (1)
- L** = low speed screw (2)
- LA** = idle speed screw (3)

If the carburetor cannot be adjusted properly, the problem may be the adjusting screws.

The high speed screw **H** has a limiter cap, which has to be removed before the screw is removed.

Always install a new limiter cap.

- Remove the carburetor, 📖 14.3
- See also carburetor troubleshooting, 📖 4.6

Low speed screw

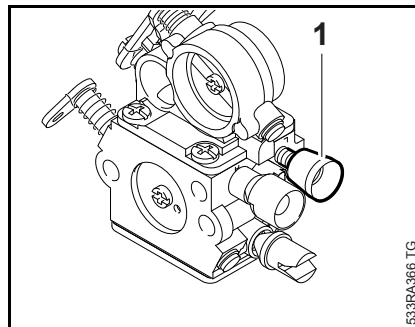

- Take out the low speed screw (1).

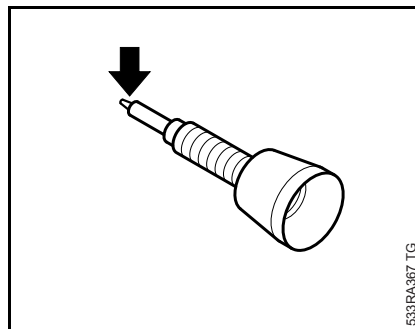

- Inspect the tip (arrow) for damage or wear and replace the screw if necessary.
- Screw down the low speed screw **L** as far as stop.
- Continue with high speed screw

High speed screw

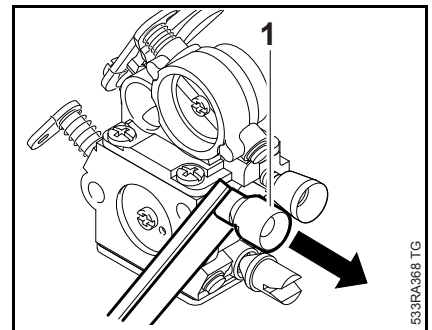

- Use tool 5910 890 4501 to pry the limiter cap (1) off the high speed screw.

Do not refit a limiter cap. Always install a new one.

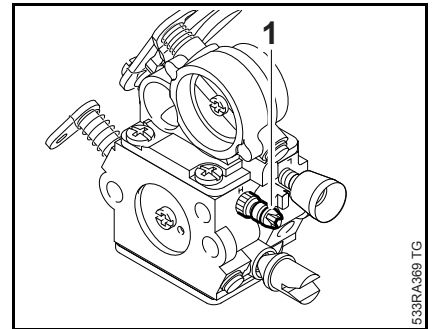

- Take out the high speed screw (1).

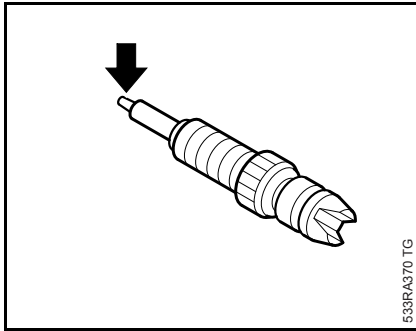

533RA370 TG

- Inspect the tip (arrow) for damage or wear and replace the screw if necessary.
- Screw home high speed screw **H** as far as stop.
- Carry out basic setting, 14.5.1

14.5 Adjusting the Carburetor

14.5.1 Basic Setting

The basic setting is necessary only if the high speed screw **H** or low speed screw **L** has to be replaced or after cleaning and adjusting the carburetor from scratch.

- Remove the limiter cap from the high speed screw, 14.4.9

It is necessary to carry out the basic setting after removing the limiter cap.

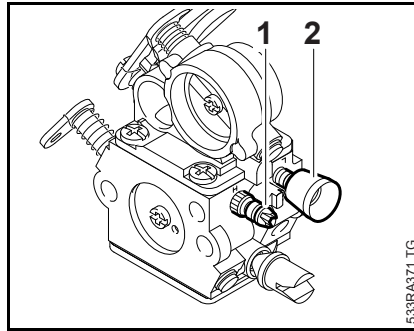

533RA371 TG

- Screw down the high speed screw **H** (1) clockwise onto its seat.
- With the high speed screw **H** (1) against its seat, unscrew it **one full turn** counterclockwise – this is the basic setting.
- Screw down the low speed screw **L** (2) clockwise onto its seat.
- With the low speed screw **L** (2) against its seat, unscrew it **one full turn** counterclockwise – this is the basic setting.

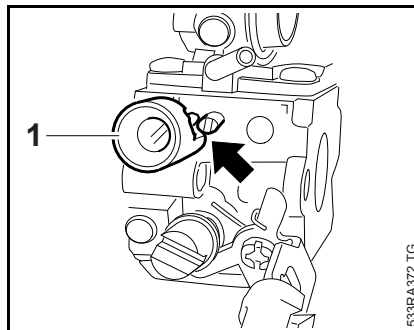

533RA372 TG

Always install a new limiter cap. First position it so that its lug is below the stop (arrow) and then press it onto the high speed screw.

- Press the limiter cap (1) onto the high speed screw **H**.

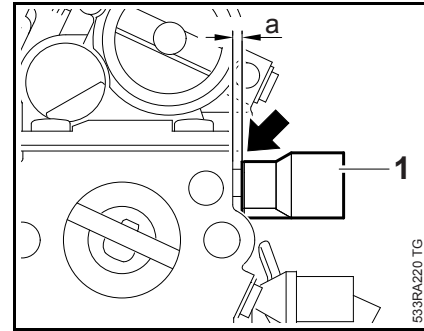

533RA220 TG

- Do not push on the limiter cap (1) as far as stop against the carburetor body (2) because it will be damaged. Maintain a minimum clearance of “a” = 1 mm (arrow).

The high speed screw **H** now has a limited range. The standard setting is obtained by turning the high speed screw **H** counterclockwise until it engages in position.

14.5.2 Standard Setting

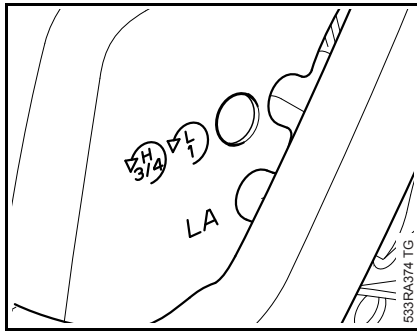

The limiter caps must not be removed for the standard setting.

Always perform the following steps before carrying out any adjustments:

- Troubleshooting, 4.6
- Check chain tension and adjust if necessary.
- Inspect the spark arresting screen (if fitted) and clean or replace if necessary.
- Check the air filter and clean or replace if necessary, 14.1

Standard Setting

- Shut down the engine
- Turn the high speed screw **H** slowly counterclockwise as far as stop, but not more than a **3/4 turn**
- Turn the low speed screw **L** slowly clockwise as far as stop, then turn it back **1 full turn**

Adjusting engine idle speed

- Carry out standard setting.
- Allow engine to warm up
- Turn the idle speed screw **LA** clockwise as far as stop or until the chain begins to run, then turn it back **3 full turns**

Erratic idling behavior, poor acceleration

(although standard setting is correct)

Idle setting too lean.

- Allow engine to warm up.
- Turn low speed screw **L** counterclockwise until the engine runs and accelerates smoothly.

It is usually necessary to change the setting of the idle speed screw (**LA**) after every correction to the low speed screw (**L**).

Adjustment for operation at high altitude

A minor correction may be necessary if engine power is not satisfactory when operating at high altitude.

- Check standard setting.
- Allow engine to warm up.
- Turn the high speed screw **H** clockwise (leaner) – no further than stop.

Turn the adjusting screws only very slightly. Even minor adjustments can noticeably affect engine running behavior.

If the setting is made too lean there is a risk of engine damage as a result of lack of lubrication and overheating.

If the adjustments produce no improvement, see the troubleshooting charts for the ignition system, carburetor and engine.

14.6 Choke and Throttle Rods

Choke Rod

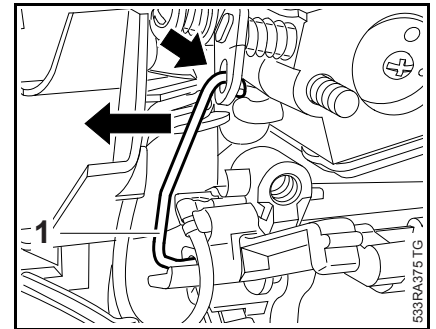

- Remove the filter base, 14.2
- Pull the carburetor out slightly and turn the choke shaft until the slot (arrow) and the choke rod's hook (1) are in line.
- Disconnect the choke rod from the lever.

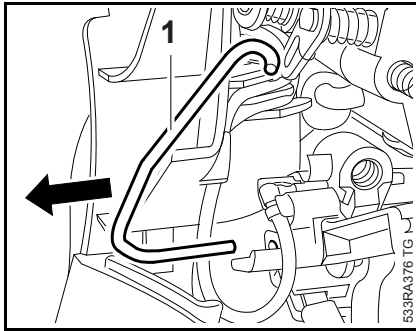

- Pull the choke rod (1) out of the switch shaft.
- Check the choke rod and replace if necessary.

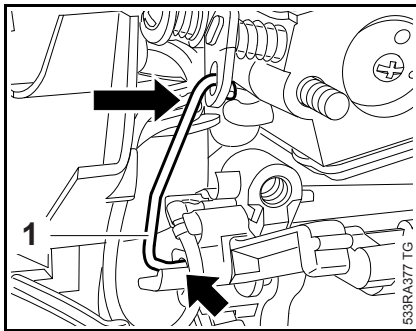

- Push the choke rod (1) into the switch shaft (arrow).
- Attach the choke rod to the lever on the choke shaft.
- Check operation.
- Reassemble all other parts in the reverse sequence.

Throttle rod

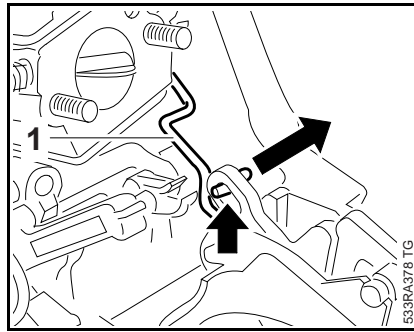

- Remove the filter base, 14.2
- Remove the handle molding, 12.2
- Disconnect the throttle rod (1) from the throttle trigger (arrow).

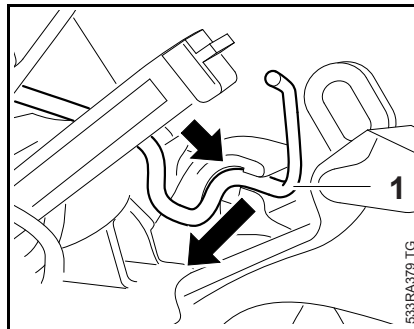

- Pull the throttle rod (1) out of its mount (arrow).
- Remove the throttle rod. Check it and replace if necessary.

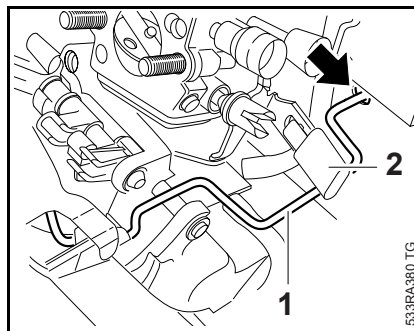

- Pass the throttle rod (1) under the throttle trigger (2) and push it into the hole (arrow).

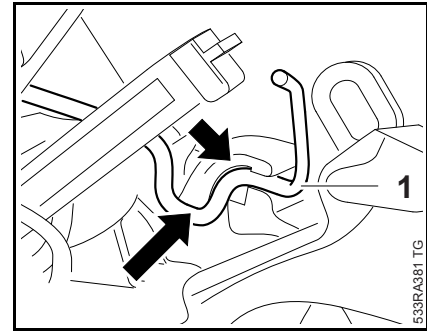

- Push the throttle rod (1) into the mount until its snaps into position.

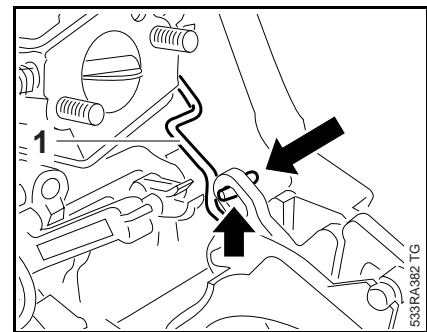

- Pull the throttle trigger upwards and attach the throttle rod (1) (arrow).

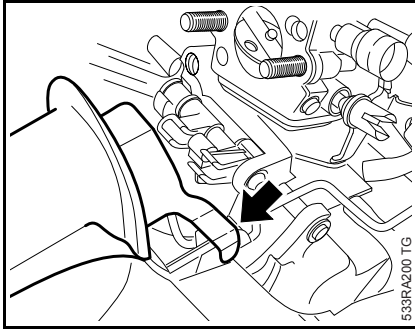

The throttle rod (arrow) is secured in position when the handle molding is installed.

- Install the handle molding, [12.2](#)
- Check operation.
- Reassemble all other parts in the reverse sequence.
- Tightening torques, [3.5](#)

14.7 Removing and Installing the Intake Manifold

A damaged intake manifold can result in engine running problems.

- Troubleshooting, [4.6](#) or [4.7](#)
- Remove the shroud, [8.4](#)
- Remove the carburetor, [14.3](#)
- Remove the carburetor carrier, [14.7.1](#)

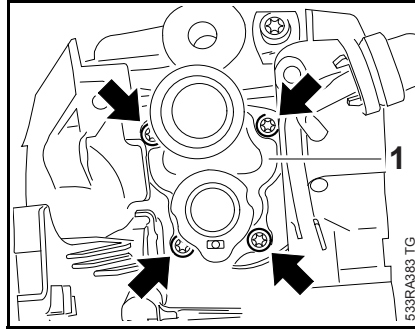

- Take out the screws (arrows).

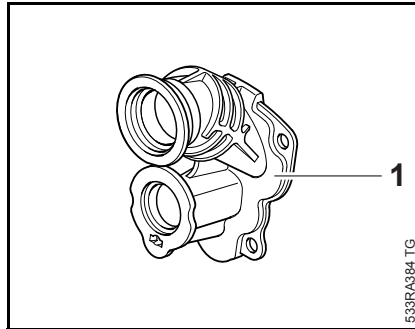

- Remove the intake manifold (1).
- Inspect the intake manifold (1) and replace if necessary – even very minor damage can cause engine running problems, [4.6](#)

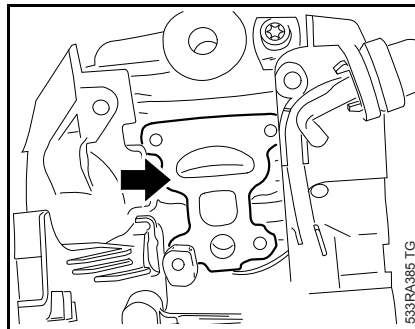

- Inspect and clean the sealing face (arrow) on the cylinder, [16](#)

The sealing face must be perfectly clean and not be damaged in any way. Components with damaged sealing faces must be replaced.

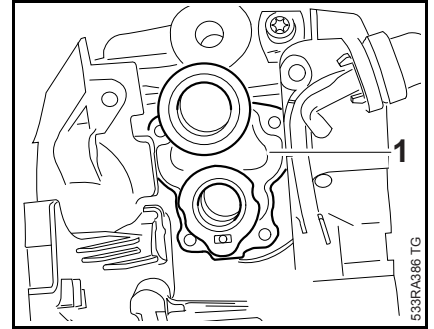

- Place the manifold (1) against the cylinder.

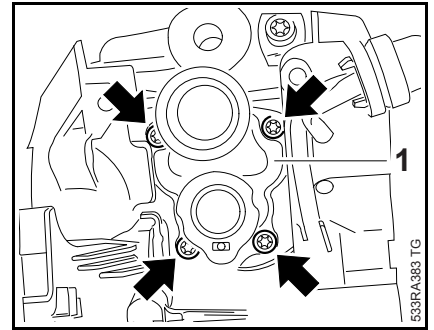

- Fit the screws (arrows) and tighten them down firmly.
- Install the carburetor carrier, [14.7.1](#)
- Reassemble all other parts in the reverse sequence.
- Tightening torques, [3.5](#)

14.7.1 Removing and Installing the Carburetor Carrier

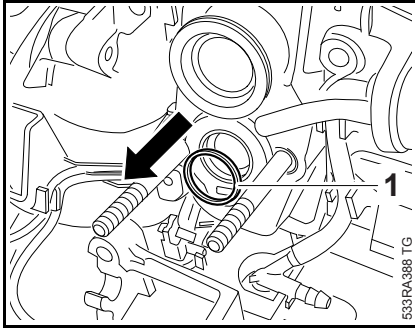

- Remove the carburetor, 14.3
- Remove the throttle rod, 14.6
- Pull off the spark plug boot and unscrew the spark plug.
- Take out the sleeve (1).

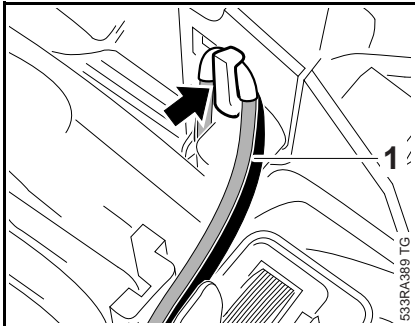

- Unhook the wiring harness (1) at the guide (arrow).

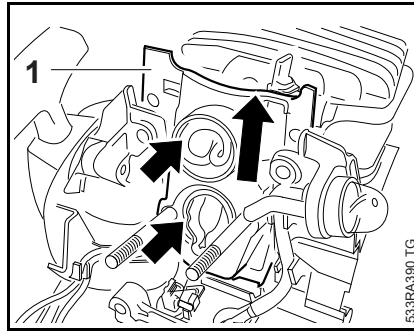

- Disconnect the fuel hose from the carburetor carrier.
- Pull the carburetor carrier (1) upwards while pushing the manifold flanges (arrows) back and out of the bores in the direction of the cylinder with one hand.
- Remove and inspect the carburetor carrier (1) and replace it if necessary.

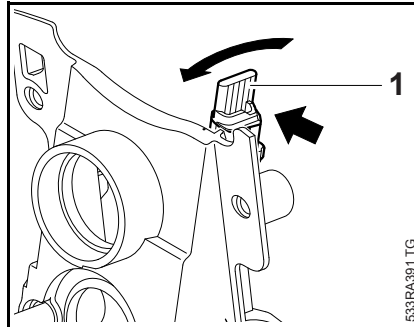

- Open the shutter (1), if fitted, and push it out of its seat (arrow).
- Check the shutter and replace it if necessary.
- Install in the reverse sequence.

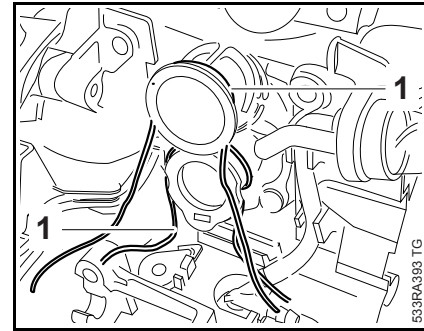

- Coat the flanges of the intake manifold with STIHL Press Fluid, 16
- To pull the manifold flanges through the bores in the carburetor carrier, wind pieces of string (1) (each about 20 cm long) around the flanges and secure them with a simple overhand knot.

Do not use pliers, pointed or sharp-edged tools.

The manifold flanges can also be fitted by hand. Observe the following points in addition to the normal assembly procedures:

- Install the carburetor carrier and position the manifold flanges against the bores.
- Pull the manifold flanges into position with one hand until they completely fill the bores.

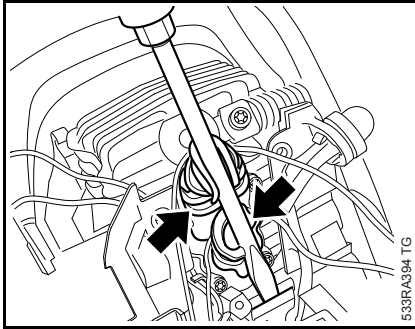

- Use a blunt screwdriver to push both manifold flanges (arrows) in the direction of the cylinder.

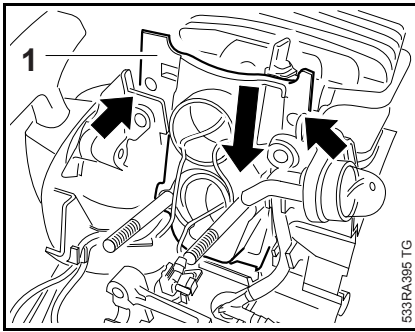

- Push the carburetor carrier (1) into the guides (arrows) in the engine housing as far as stop.

When installing, make sure the wiring harness is not pinched and the manifold is not damaged.

- Pass the ends of the strings through the bores (arrows) and position the manifold flanges against the bores in the carburetor carrier (1).

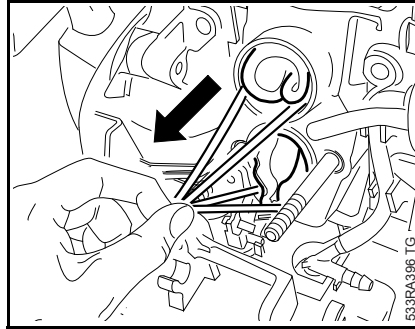

- Pull the ends of the strings with the manifold flanges (arrows) through the bores.

The manifold flanges are thus pulled through the carburetor carrier and into position without being damaged.

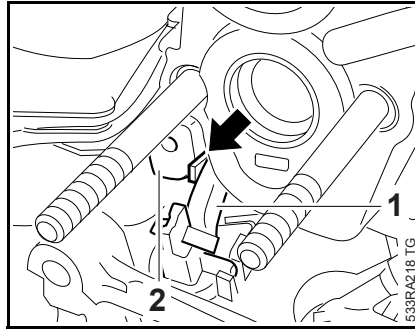

- Position the fuel hose (1) in the guide (arrow) on the carburetor carrier and route the hose connector (2) over the rib – fuel hose is attached.

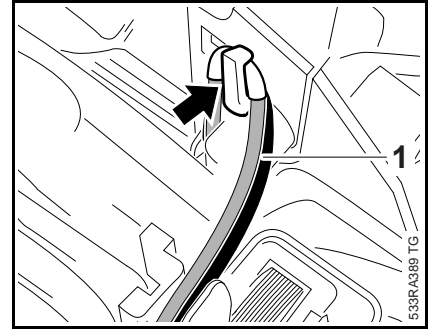

- Fit the wiring harness (1) in the guide (arrow).

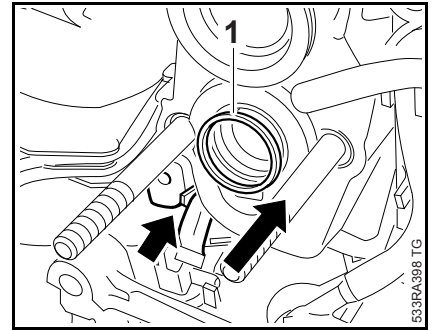

- Fit the sleeve (1).



The fuel hose (arrow) must be attached to the carburetor carrier.

- Make sure the wiring is properly seated in its guides.
- Reassemble all other parts in the reverse sequence.
- Tightening torques, 3.5

14.8 Tank Vent

14.8.1 Testing

If problems occur on the carburetor or the fuel supply system, also check and clean the tank vent and replace it if necessary. Check function by performing pressure and vacuum tests on the tank via the fuel hose.

- Open the tank cap and drain the fuel tank. Dispose of fuel properly,  1.
- Close the tank cap.
- Remove the carburetor,  14.3
- Pull off the fuel hose and elbow connector,  14.9.2

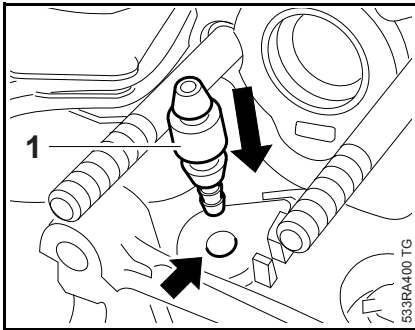

- Push the nipple (1) 0000 855 9200 into the fuel hose (arrow).

Machines with Manual Fuel Pump

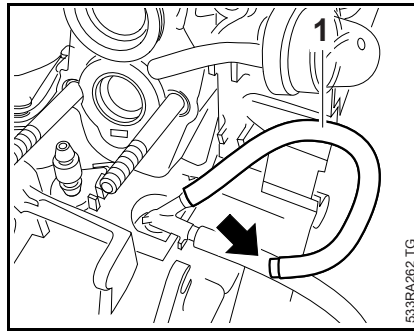

- Remove the manual fuel pump,  14.8.3
- Pull the fuel hose (1) out of the guides.
- Disconnect the fuel hose from the fuel pump (1).
- Seal the fuel hose (1) with a plug (arrow).

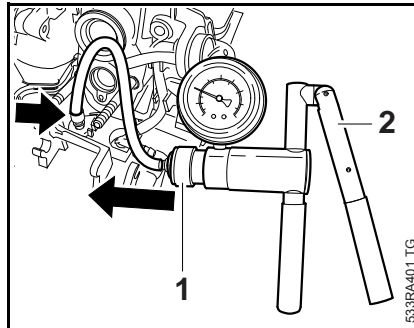

Vacuum test

- Push the ring (1) to the left and connect the pump (2) 0000 850 1300 to the nipple (arrow)
 - subject the fuel tank to a vacuum.

Equalization of pressure takes place via the tank vent. There must be no build-up of vacuum in the tank.

- Clean the area around the tank vent.

- If necessary, replace the tank vent or the tank,  14.8

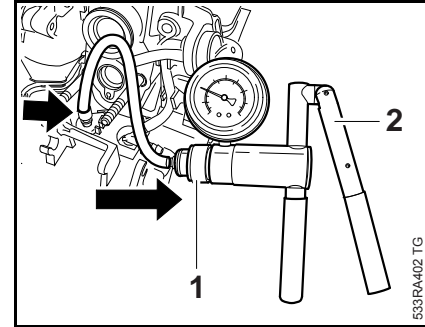

Pressure test

- Push the ring (1) to the right and connect the pump (2) 0000 850 1300 to the nipple (arrow) – pressurize the fuel tank.
- Operate the pump until the pressure gauge indicates a pressure of 0.5 bar. If this pressure remains constant for at least 20 seconds, the tank, including the tank vent, is airtight. If it drops, the leak must be found and the defective part replaced.
- Reassemble in the reverse sequence.

14.8.2 Removing and Installing

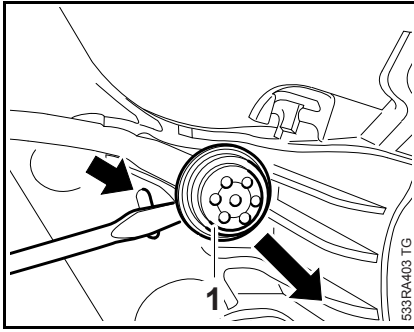

- Remove the handle frame, [11.4](#)
- Pry out the tank vent (1) as shown (arrow).

Always install a new tank vent.

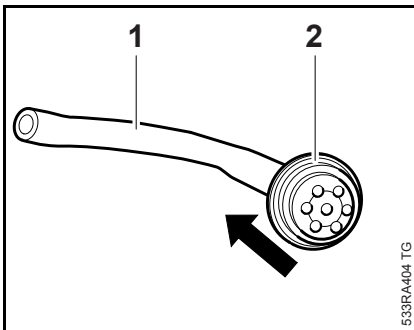

- Disconnect the fuel hose (1), check and replace if necessary.
- Push the new tank vent (2) into the fuel hose (1) as far as stop.

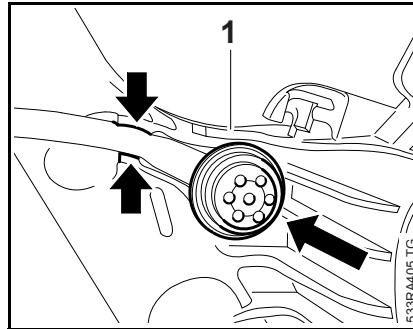

- Coat seat of tank vent with STIHL Press Fluid, [16](#)
- Press the tank vent into its seat (arrows) in the handle frame (1) by hand.
- Install the handle frame, [11.4](#)

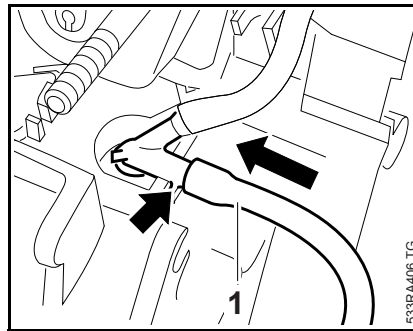

- Push the fuel hose (1) onto the stub (arrow).
- Reassemble all other parts in the reverse sequence.
- Tightening torques, [3.5](#)

14.8.3 Manual Fuel Pump

Not installed in all machine versions. A faulty manual fuel pump must be replaced.

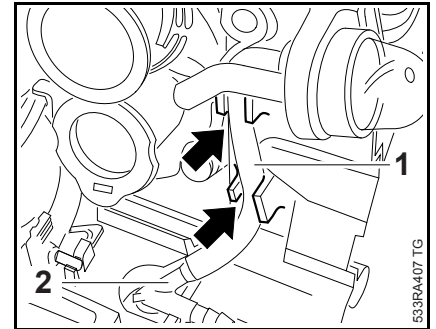

- Remove the filter base, [14.2](#)
- Remove the carburetor, [14.3](#)
- Pull the fuel hose (1) out of the guides (arrows).
- Check the fuel hose (1), pull it off the connector (2) and replace if necessary.
- Install in the reverse sequence.

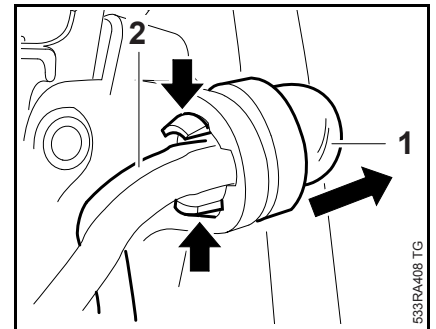

- Press the retaining tabs (arrows) together and pull out the fuel pump (1).
- Pull the fuel pump (1) off the fuel hose (2).

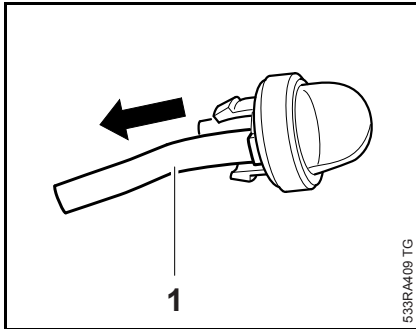

- Pull off the fuel hose (1).
- Inspect the fuel hoses and replace if necessary.

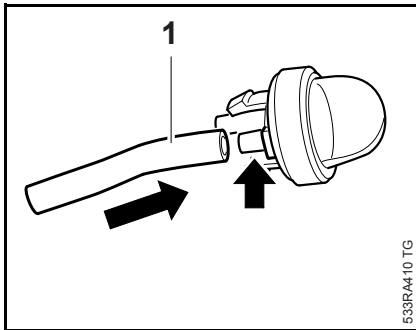

- Push the fuel hose (1) onto the short stub (arrow) of the new fuel pump.

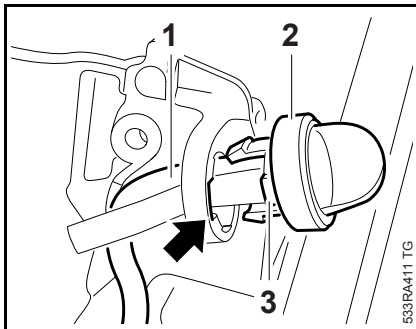

- Push the fuel pump into the fuel hose (1).
- Line up the lug (3) with the recess (arrow) and push the fuel pump (2) into the bore until the retaining tabs engage.

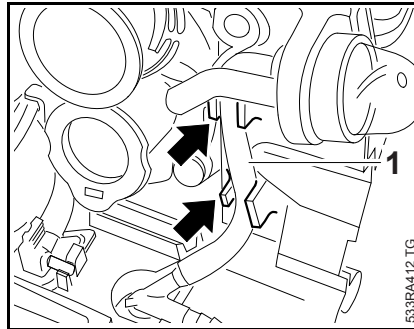

- Push the fuel hose (1) into its guides (arrows).
- Check operation.
- Reassemble all other parts in the reverse sequence.
- Tightening torques, 3.5

14.9 Fuel Intake

14.9.1 Pickup Body

Any impurities mixed with the fuel are retained by the pickup body (filter). The fine pores of the filter eventually become clogged with minute particles of dirt. This restricts the passage of fuel and results in fuel starvation.

In the event of trouble with the fuel supply system, always check the fuel tank and the pickup body first.

- Troubleshooting, 4.6 or 4.7

Do not use pliers, pointed or sharp-edged tools.

Clean the fuel tank if necessary.

- Open the tank cap and drain the tank.
- Pour a small amount of clean gasoline into the tank. Close the tank and shake the saw vigorously
- Open the tank again and drain it

Dispose of fuel properly in accordance with environmental requirements.

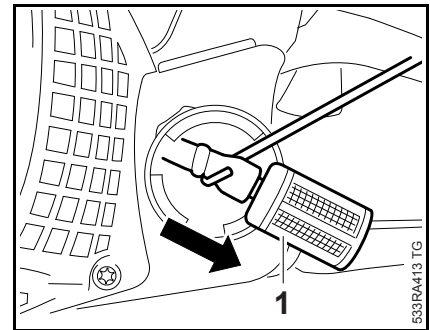

- Open the tank cap.
- Use hook 5910 893 8800 to remove the pickup body from the fuel tank.

Do not overstretch the fuel hose.

- Pull the pickup body (1) off the fuel hose, check it and clean or replace if necessary.
- Install in the reverse sequence.

14.9.2 Fuel Intake Hoses

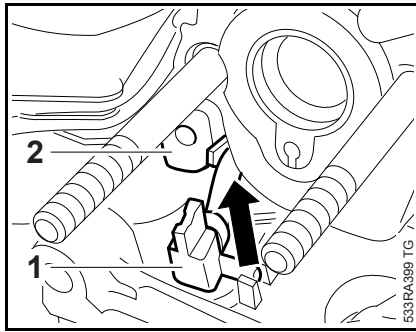

- Remove the carburetor, 14.3
- Remove the pickup body, 14.9.1
- Disconnect the fuel hose from the carburetor carrier (arrow).
- Pull off the elbow connector (1) with fuel hose (2).

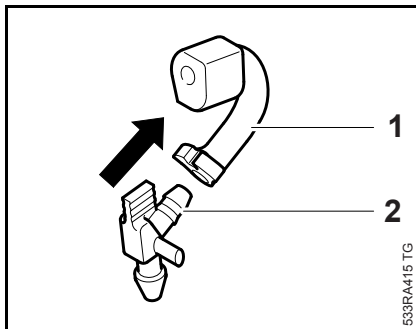

- Pull the fuel hose (1) off the elbow connector (2).

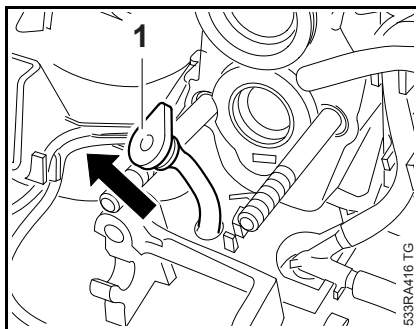

- Pull the fuel hose (1) out of the fuel tank.

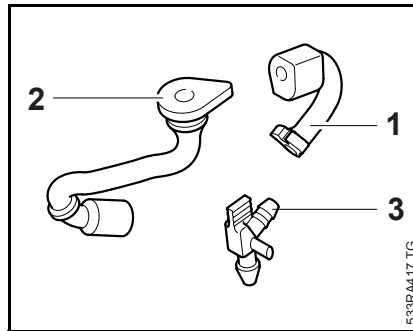

- Inspect fuel hoses (1+2) and elbow connector (3) and replace if necessary.

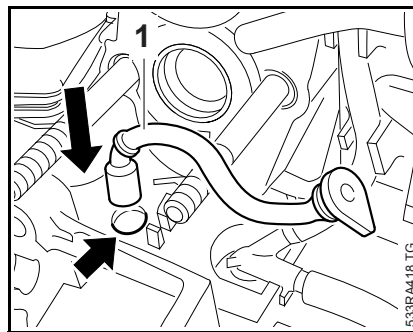

- Push the fuel hose (1) through the hole (arrow) in the fuel tank.

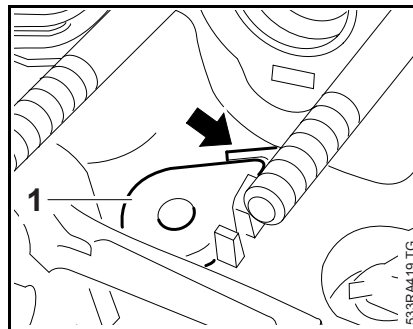

- Line up the fuel hose (1) and press it into the housing bore until its flange is positioned as shown (arrow) and is flush with the housing.
- Coat with STIHL Press Fluid, 16

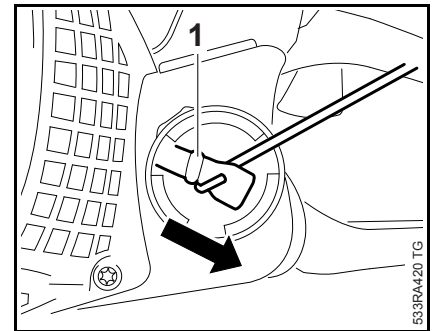

- Use the hook 5910 893 8800 to pull the fuel intake hose (1) out of the fuel tank.

Do not overstretch the fuel hose.

- Install the pickup body, 14.9.1
- Close the tank cap.

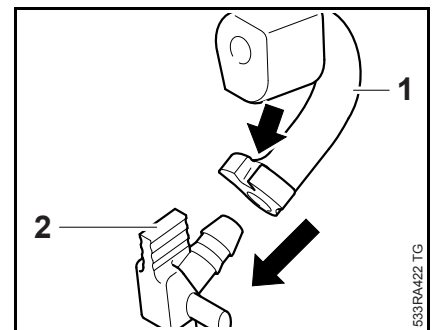

- Push the fuel hose (1) onto the elbow connector as far as stop, making sure the slot (arrow) engages the lug (2).

Ensure there is no gap between the connector and fuel hose.

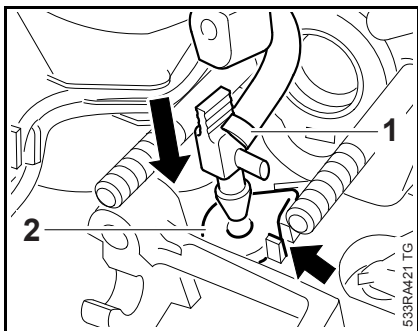

- Push the elbow connector (1) with fuel hose into fuel hose (2), making sure the lug engages the recess (arrow).

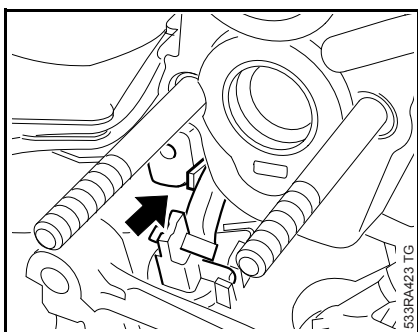

The fuel hose (arrow) must be located in the recess between the carburetor carrier and engine housing.

- Reassemble all other parts in the reverse sequence.

Tightening torques, 3.5

14.9.3 Fuel Hoses, Tank Vent / Manual Fuel Pump

The fuel hoses for the manual fuel pump are described in the chapter on “manual fuel pump”, 14.8.3

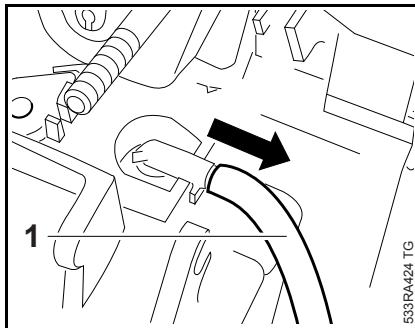

- Remove the carburetor, 14.3
- Remove the switch shaft, 12.1
- Pull off the fuel hose (1).

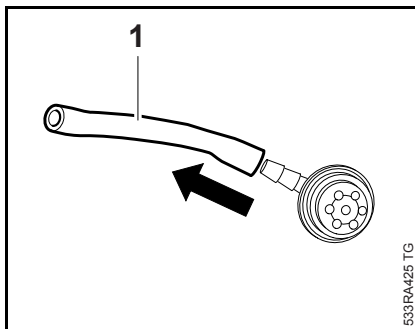

- Remove the tank vent, 14.8.2
- Pull off and inspect the fuel hose (1) and replace if necessary.
- Install in the reverse sequence.

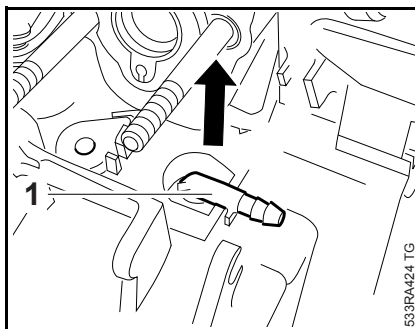

- Pull out the connector (1).

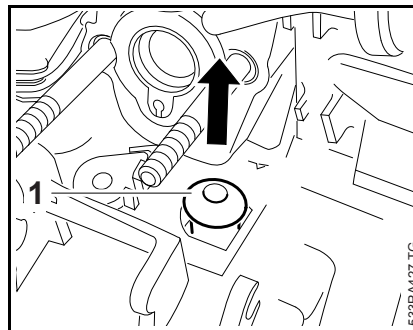

- Pry out the grommet (1).

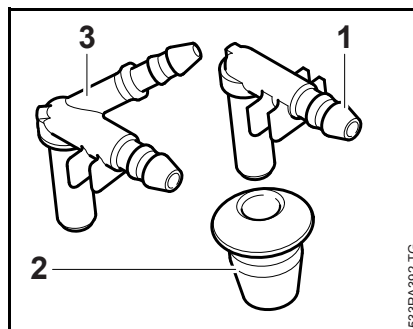

- Inspect the connector (1) and grommet (2) and replace if necessary.
- Connector (3) is installed in machines with a manual fuel pump.

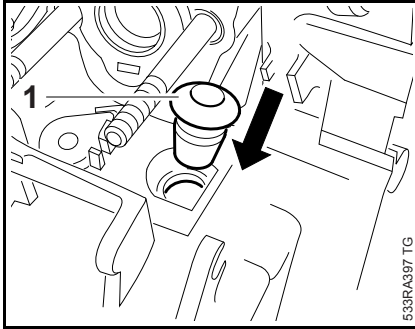

- Coat the grommet with STIHL Press Fluid, 16
- Press the grommet (1) into the bore (arrow) until it is properly seated.

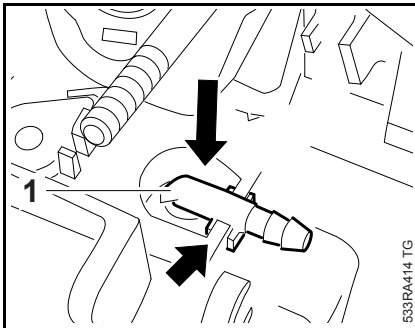

- Push the connector (1) into the grommet and locate it on the web (arrow).

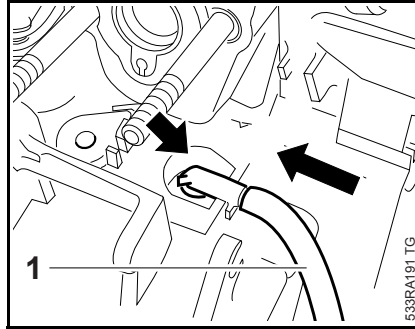

- Push the fuel hose (1) onto the connector (arrow).
- Install the manual fuel pump (if standard), 14.8.3
- Reassemble all other parts in the reverse sequence.
- Tightening torques, 3.5

14.9.4 Fuel Tank Cap

See instruction manual.

- Open the tank cap.

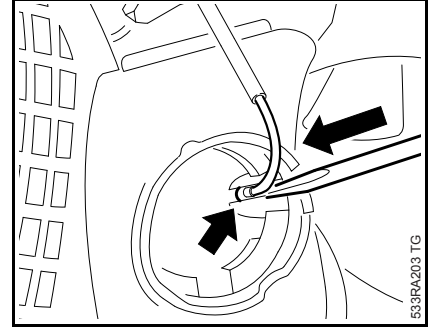

- Disconnect the nipple inside the tank (arrow).
- Check the tank cap and replace sealing ring or tank cap.
- Install in the reverse sequence.
- Carry out leakage test.

15. Special Servicing Tools

New Special Tools

No.	Part Name	Part No.	Application	Rem.
1	Test flange	1139 893 2500	Leakage test	
2	Locking strip	0000 893 5904	Blocking the crankshaft	
3	Sleeve	5910 893 1707	For installing tool 10	
4	Installing tool - Puller 1130 - Installer 1130	1123 890 2202	Installing oil pump Removing oil pump Installing oil pump	
5	Combination wrench	0000 890 3400	Various operations on the machine	

Existing Special Tools

No.	Part Name	Part No.	Application	Rem.
1	Assembly stand	5910 890 3101	Holding saw for repairs (includes mount 5910 850 1650)	
2	Mount for assembly stand	5910 850 1650	Clamping saw to assembly stand (only for assembly stand 5910 890 3100)	
3	Carburetor and engine tester	0000 850 1300	Testing engine and carburetor for leaks	
4	Sealing plate	0000 855 8106	Sealing the exhaust port	
5	Flange - Hose for leakage test - Nipple	1123 855 4200 1110 141 8600 0000 855 9200	Sealing the exhaust port Testing carburetor for leaks Testing carburetor for leaks	
6	Puller	5910 890 4500	Removing limiter caps	
7	Screwdriver - Setting disk	5910 890 2304 5910 893 6600	Adjusting carburetor with limiter cap Add-on for screwdriver (adjusting carburetor)	
8	Screwdriver	5910 890 2305	Adjusting carburetor	
9	Socket DIN 3124-S 19 x12.5L	5910 893 5613	Clutch	
10	Hook	5910 890 2800	Detaching springs on clutch shoes	
11	Socket, 13 mm, long	5910 893 2804	Machines with ErgoStart, removing flywheel nut	
12	Socket DIN 3124, 13 mm	5910 893 5608	Removing flywheel nut	
13	Puller	1116 893 0800	Releasing flywheel	1
14	Setting gauge	1111 890 6400	Adjusting air gap between ignition module and flywheel	
15	Ignition system tester, ZAT 4	5910 850 4503	Testing ignition system	
16	Ignition system tester, ZAT 3	5910 850 4520	Testing ignition system	

No.	Part Name	Part No.	Application	Rem.
17	Puller	5910 890 4400	Removing oil seals	1
	- Jaws (No. 3.1 profile)	0000 893 3706	Removing oil seal(s)	1
	- Jaws (No. 4 profile)	0000 893 3711	Removing oil seal(s)	1
18	Press sleeve	1123 893 2400	Installing oil seal	
19	Installing sleeve	1118 893 4602	Protects oil seal at clutch side	
20	Assembly drift	1110 893 4700	Removing and installing piston pins	
21	Installing tool 10	5910 890 2210	Installing hookless snap rings in piston	
22	Assembly tube	1117 890 0900	Attaching clutch springs	
23	Stud puller M8	5910 893 0501	Removing bar mounting studs	
24	Installing tool	0000 890 2201	Installing rope guide bushing	
25	Installing tool	1116 893 4800	Rewinding rewind spring	
26	Hook	5910 893 8800	Removing pickup body	
27	Torque wrench	5910 890 0302	0.5 to 18 Nm	
28	Torque wrench	5910 890 0312	6 to 80 Nm	
29	Screwdriver bit, T 27 x 125	0812 542 2104	Removing and installing Torx screws with electric or pneumatic screwdrivers; tighten down screws with torque wrench	
30	T-handle screwdriver, T 27 x 150	5910 890 2400	IS-P screws (4 mm)	
31	Crimping tool	5910 890 8210	Attaching connectors to electrical wires	
32	Pliers DIN 5254-A 19	0811 611 8380	Removing and installing external circlips	

Remarks:

1) Use for releasing only.

16. Servicing Aids

No.	Part Name	Part No.	Application
1	Lubricating grease (225 g tube)	0781 120 1111	Oil seals, sliding and bearing points
2	STIHL special lubricant	0781 417 1315	Bearing bore in rope rotor, rewind spring in fan housing
3	STIHL Press Fluid OH 723	0781 957 9000	Rubber elements, fuel hoses, etc.
4	STIHL multipurpose grease	0781 120 1109	High voltage output on ignition module
5	Dirko HT red sealant	0783 830 2000	Engine pan, oil seals (outside)
5	Medium-strength threadlocking adhesive (Loctite 242)	0786 111 2101	
6	High-strength threadlocking adhesive (Loctite 270)	0786 111 2109	
7	High-strength threadlocking adhesive (Loctite 648)	0786 111 2117	
8	Standard commercial solvent-based degreasant containing no chlorinated or halogenated hydrocarbons		Cleaning sealing faces and carburetor, crankshaft stubs and flywheel taper

englisch / english

0455 533 0123. VA0.K12.