

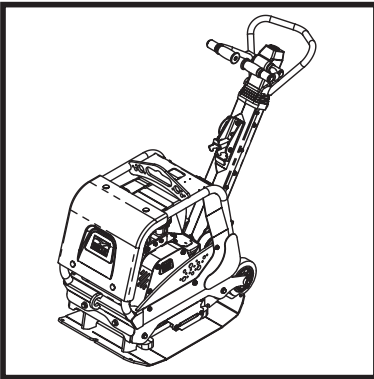

BELLE RPX 35

870/10024/2
06/19



- Spare Parts Book
- Pièces Détachées
- Libro Despiece
- Onderdelen Boekje
- Reservedele Skrift
- Ersatzteilhandbuch
- Bruksanvisning
- Bruksanvisning
- Varaosaluettelo
- Запасные Части Книга

150

(GB) Operators Manual	6
(US) Operators Manual	19
(F) Manuel De L'Opérateur	32
(E) Manual del Operador	45
(NL) Handleiding	58
(DK) Betjeningsvejledning	71
(D) Bedienungshandbuch	84
(S) Bruksanvisning	97
(NO) Betjene Håndbok	110
(SF) Käyttöohje	123
(RUS) Руководство для оператора	136

EC DECLARATION OF CONFORMITY / DECLARATION CE DE CONFORMITE / DECLARACIÓN DE CONFORMIDAD CE / DECLARAÇÃO CE DE CONFORMIDADE / EG-VERKLARING VAN OVERENSTEMMING / EF OVERENSSTEMMELSESERKLÆRING



We, **Belle Group Sheen UK, Sheen, Nr. Buxton, Derbyshire, SK17 0EU, GB**, hereby certify that if the product described within this certificate is bought from an authorised Belle Group dealer within the EEC, it conforms to the following EEC directives: 2006/42/CE (This directive replaces directive 98/37/EC), Electromagnetic Compatibility Directive 2004/108/CE (as amended by 89/336/EEC, 92/31/EEC & 93/68 EEC). The Waste Electrical and Electronic Equipment (WEEE) 2002/96/CE, the low voltage directive 2006/95/CE, BS EN ISO 12100-1:2003 Safety of machinery and associated harmonised standards, where applicable. Noise emissions conform to directives 2000/14/EC Annex VI & 2005/88/EC, for machines under article 12 the notified body is **AVT Reliability, Unit 2 Easter Court, Europa Boulevard, Warrington, Cheshire, WA5 7ZB, GB**.
Noise Technical files are held by Ray Neilson at the Belle group Head Office address which is stated above.



Nous soussignés, **Belle Group Sheen UK, Sheen, Nr. Buxton, Derbyshire, SK17 0EU, GB**, certifions que si le produit décrit dans ce certificat est acheté chez un distributeur autorisé Belle Group au sein de la CEE, il est conforme aux normes CEE ci-après: 2006/42/CE (Cette norme remplace la norme 98/37/CE), Norme compatible pour l'électromagnétisme 2004/108/CE (modifiée par 89/336/EEC, 92/31/EEC & 93/68 EEC). Les déchets électriques, et d'équipement électronique 2002/96/CE, caractéristiques basse tension 2006/95/CE, BS EN ISO 12100-1:2003 Norme de sécurité des machines et des critères associés et configurés, si applicable. Les émissions de bruit sont conformes à la directive 2000/14/CE Annexe VI et 2005/88/EC pour machines, article 12, l'objet mentionné est **AVT Reliability, Unit 2 Easter Court, Europa Boulevard, Warrington, Cheshire, WA5 7ZB, GB**.
Bruit des fichiers techniques sont détenues par Ray Neilson à l'adresse du groupe Belle Siège qui est indiqué ci-dessus.



La Sociedad, **Belle Group Sheen UK, Sheen, Nr. Buxton, Derbyshire, SK 17 0EU, GB**, por el presente documento certifica que si el producto descrito en este certificado es comprado a un distribuidor autorizado de Belle Group en la CEE, este es conforme a las siguientes directivas: 2006/42/CE de la CEE (Esta directiva sustituye a la Directiva 98/37/CE), Directiva 2004/108/CE sobre Compatibilidad Electromagnética (según enmiendas 89/336/EEC, 92/31/EEC & 93/68 EEC). Los residuos eléctricos y electrónicos (RAEE) 2002/96/CE, Directiva sobre Bajo Voltaje 2006/95/CE, BS EN ISO 12100-1:2003 de Seguridad de Maquinaria y Niveles armonizados estándares asociados donde sean aplicables. Emisión de Ruidos conforme a la Directiva 2000/14/CE Anexo VI y 2005/88/EC para máquinas bajo artículo 12 la mencionada unidad está en **AVT Reliability, Unit 2 Easter Court, Europa Boulevard, Warrington, Cheshire, WA5 7ZB, GB**.
Archivos de ruido técnicos están en manos de Ray Neilson en la dirección del grupo Belle Sede de la que se ha dicho.



O signatário, **Belle Group Sheen UK, Sheen, Nr. Buxton, Derbyshire, SK 0EU, GB**, pelo presente, declara que se o produto descrito neste certificado foi adquirido a um distribuidor autorizado do Belle Group em qualquer país da UE, está em conformidade com o estabelecido nas seguintes diretivas comunitárias: 2006/42/CE (Esta directiva substitui a Directiva 98/37/CE), Directiva de Compatibilidade Electromagnética 2004/108/CE (conforme corrigido pelas 89/336/EEC, 92/31/EEC & 93/68 EEC). O Eléctrico de Desperdiço e Equipamento Eléctrico (DEEE) 2002/96/CE, a directiva de baixa voltagem 2006/95/CE, BS EN ISO 12100-1:2003 Segurança da maquinaria e às normas harmonizadas afins se aplicáveis. As emissões de ruído respeitam e estão dentro das diretivas para máquinas 2000/14/CE Anexo VI & 2005/88/EC, artigo 12, sendo o organismo notificado **AVT Reliability, Unit 2 Easter Court, Europa Boulevard, Warrington, Cheshire, WA5 7ZB, GB**.
Arquivos de ruído técnicos são detidos por Ray Neilson no endereço Escritório Belle grupo Cabeça que é dito acima.



Ondergetekende, **Belle Group Sheen UK, Sheen, Nr. Buxton, Derbyshire, SK17 0EU, GB**, verklaren hierbij dat als het product zoals beschreven in dit certificaat is gekocht van een erkende Belle Group dealer binnen de EEG, het voldoet aan de volgende EEG richtlijnen: 2006/42/CE (Deze richtlijn vervangt Richtlijn 98/37/EC), Electromagnetische Compatibiliteit Richtlijn 2004/108/CE (geamendeerd door 89/336/EEC, 92/31/EEC & 93/68 EEC). De afgedankte elektrische en elektronische apparatuur (AEEA) 2002/96/CE, de Laagspannings Richtlijn 2006/95/CE, BS EN ISO 12100-1:2003 Veiligheid van Machines, en hieraan gekoppelde geharmoniseerde Standaarden, waar deze van toepassing is. Geluidshinder te voldoen aan de richtlijnen 2000/14/EG en 2005/88/EG bijlage VI, voor toestel onder stuk 12 naar de notified troep zit **AVT Reliability, Unit 2 Easter Court, Europa Boulevard, Warrington, Cheshire, WA5 7ZB, GB**.
Lawaai Technische dossiers zijn in handen van Ray Neilson op de Belle groep hoofdkantoor adres, dat staat boven.



Vi, **Belle Group Sheen UK, Sheen, Nr. Buxton, Derbyshire, SK17 0EU, GB**, erklærer hermed, at hvis det i dette certifikat beskrevne produkt er købt hos en autoriseret Belle Group forhandler i EU, er det i overensstemmelse med følgende EØF-direktiver: 2006/42/CE (Dette direktiv erstatter direktiv 98/37/EF), 2004/108/EØF (som ændret ved 89/336/EEC, 92/31/EØF & 93/68 EØF), Afald af elektrisk og elektronisk udstyr (WEEE) 2002/96/CE, lavspændingsdirektivet 2006/95/CE, BS EN ISO 12100-1:2003 Maskinsikkerhed og tilhørende harmoniserede standarder, hvor det er relevant. Støjmission i overensstemmelse med direktiverne 2000/14/EF bilag VI og 2005/88/EF, for maskiner under paragraf 12. Det bemyndigede organ er **AVT Reliability, Unit 2 Easter Court, Europa Boulevard, Warrington, Cheshire, WA5 7ZB, Storbritanien**.
Støj Tekniske filer er i besiddelse af Ray Neilson på Belle-gruppen hovedkontoret adresse, som er nævnt ovenfor.

PRODUCT TYPE	TYPE DE PRODUIT.....	TIPO DE PRODUCTO
MODEL	MODELE	MODELO
SERIAL No.....	N° DE SERIE	N° DE SERIE
DATE OF MANUFACTURE.....	DATE DE FABRICATION	FECHA DE FABRICACIÓN.....
SOUND POWER LEVEL MEASURED /	NIVEAU DE PUISSANCE SONORE MESUREE /	NIVEL DE POTENCIA ACÚSTICA MEDIDO /
.....(GUARANTEED)(GARANTIE)(GARANTIZADO)
WEIGHT	POIDS	PESO
TIPO DE PRODUCTO.....	PRODUCTTYPE.....	PRODUKTTYPE.....
MODELO.....	MODEL	MODEL
NO. DE SERIE.....	SERIENUMMER	SERIENR.....
DATA DE FABRIC.....	FABRICAGEDATUM	FREMSTILLINGSDATO
NIVEL DE POTENCIA DE SOM MEDIDO /	GEMETEN GELUIDSSTERKTE NIVEAU /	LYDEFFEKTNIVEAU MÅLT /
.....(GARANTIDO)(EGARANDEERD)(GARANTERET)
PESO.....	GEWICHT	VÆGT.....

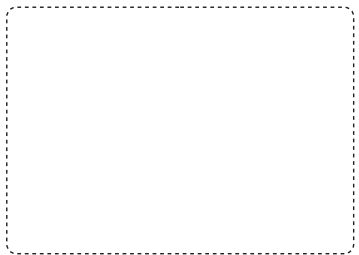

Signed by:
 Signature:
 Medido por:
 Assinado por:
 Getekend door:
 Underskrevet af:

Ray Neilson

Managing Director - On behalf of BELLE GROUP (SHEEN) UK.
Le Directeur Général - Pour le compte de la SOCIETE BELLE GROUP (SHEEN) UK.
Director Gerente - En nombre de BELLE GROUP (SHEEN) UK.
Director-Geral - Em nome de BELLE GROUP (SHEEN) UK.
Algemeen Directeur - Namens BELLE GROUP (SHEEN) UK.
Administrerende direktør - På vegne af BELLE GROUP (SHEEN) UK.

Place of Declaration - Sheen, Nr. Buxton, Derbyshire, SK17 0EU, UK
Lieu de déclaration - Sheen, Nr. Buxton, Derbyshire, SK17 0EU, UK
Declaración hecha en - Sheen, Nr. Buxton, Derbyshire, SK17 0EU, UK
Lugar de Declaração - Sheen, Nr. Buxton, Derbyshire, SK17 0EU, UK
Plaats van de Verklaring - Sheen, Nr. Buxton, Derbyshire, SK17 0EU, UK
Sted i erklæring - Sheen, Nr. Buxton, Derbyshire, SK17 0EU, UK

Date of Declaration - 2017.....
Date de déclaration - 2017.....
Fecha de la declaración - 2017.....
Data da Declaração - 2017.....
Datum van de verklaring - 2017.....
Dato for erklæringer - 2017.....

EGKONFORMITÄTSEKTLÄRNING / DICHIARAZIONE CE DI CONFORMITÀ / EG-VERKLARING VAN OVEREENSTEMMING / EC SAMSVARSERKLÆRING / EY-YHDENMUKAISUUSILMOITUS / DEKLARACJA ZGODNOSCI Z PRZEPISAMI UE

(D) Wir, **Belle Group Sheen UK, Sheen, Nr. Buxton, Derbyshire, SK17 0EU, GB**, bestätige hiermit, dass, wenn das Produkt innerhalb dieser Bescheinigung ist von einem gekauft zugelassen Belle Group-Händler innerhalb der EWG, so entspricht sie den folgenden EG-Richtlinien: 2006/42/CE (Diese Richtlinie ersetzt die Richtlinie 98/37/EG), elektromagnetische Kompatibilität Richtlinie 2004/108/EG (geändert durch 89/336/EEG, 92/31/EWG und 93/68 EWG), Die Elektro- und Elektronik-Altgeräte (WEEE) 2002/96/CE, der Niederspannungs-Richtlinie 2006/95/CE, BS EN ISO 12100-1:2003 Sicherheit von Maschinen und der damit verbundenen harmonisierten Normen, sofern zutreffend. Geräuschemissionen entsprechen der Richtlinie 2000/14/EG Anhang VI und 2005/88/EG, für Maschinen gemäß Artikel 12 der benannten Stelle ist **AVT Reliability, Unit 2 Easter Court, Europa Boulevard, Warrington, Cheshire, WA5 7ZB, GB**.
Lärm Technische Dateien werden von Ray Neilson im Belle Group Head Office Adresse, die oben angegeben statt.

(I) Il Gruppo Belle Sheen UK, Sheen, Nr. Buxton, Derbyshire, SK17 0EU, GB, certifica che, se il prodotto descritto nel presente certificato viene acquistato da un rivenditore autorizzato Belle gruppo all'interno della CEE, e conforme alle seguenti direttive CEE: 2006/42/CE (presente direttiva sostituisce la direttiva 98/37/CE), elettromagnetica compatibilità con la direttiva 2004/108/CE (modificata dalla 89/336/CEE, 92/31/CEE e 93/68 CEE). L'Elettro di Spreco e l'Apparecchiatura Elettronica (WEEE) 2002/96/CE, la direttiva bassa tensione 2006/95/CE, BS EN ISO 12100-1:2003 Sicurezza del macchinario e le relative norme armonizzate, se del caso. Emissioni sonore conformi alla direttiva 2000/14/CE, allegato VI e 2005/88/EG, per le macchine a norma dell'articolo 12, l'organismo notificato **AVT Reliability, Unit 2 Easter Court, Europa Boulevard, Warrington, Cheshire, WA5 7ZB, GB**.
File rumore tecnici sono tenuti da Ray Neilson all'indirizzo dell'Ufficio gruppo Belle Sede che è riportata sopra.

(S) Underteknede, **Belle Group Sheen UK, Sheen, Nr. Buxton, Derbyshire, SK17 0EU, GB**, Storbritannien, intygar härmed att om den produkt som beskrivs i detta intyg är köpt från en auktoriserad Belle-återförsäljare inom EEG, överensstämmer med följande EEG-direktiv: 2006/42/CE (Detta direktiv ersätter direktiv 98/37/EG), Elektromagnetisk kompatibilitet 2004/108/CE (ändrad genom direktiv 89/336/EEG, 92/31/EEG och 93/68 EEC), Avfallat Elektrisk og Elektronisk Utsstyr (WEEE) 2002/96/CE, lågsämningsdirektiv 2006/95/CE, BS EN ISO 12100-1:2003 Maskinsäkerhet och tillhörande harmoniserade standarder, i förekommande fall. Buller följa direktiv 2000/14/EG bilaga VI og 2005/88/EG till maskiner enligt artikel 12 anmälda organet är **AVT Reliability, Unit 2 Easter Court, Europa Boulevard, Warrington, Cheshire, WA5 7ZB, Storbritannien**.
Buller Tekniska filer innehas av Ray Neilson på Belle Group Huvudkontor adress som anges ovan.

(NO) Vi, **Belle Group Sheen UK, Sheen, Nr. Buxton, Derbyshire, SK17 0EU, GB**, herved bekrefter at hvis produktet er beskrevet i dette sertifikatet er kjøpt fra en autoriseret Belle Group forhandler innenfor EØS, følger det med til følgende EEC direktiver: 2006/42/CE (Dette direktivet erstatter direktiv 98/37/EF), Det elektromagnetisk kompatibilitets-direktiv 2004/108/CE (endret ved 89/336/EEC, 92/31/EEC og 93/68 EEC), Avfallat Elektrisk og Elektronisk Utsstyr (WEEE) 2002/96/CE, Lavspenningsdirektiv 2006/95/CE, BS EN ISO 12100-1:2003 Sikkerhet av maskiner og tilhørende harmoniserte standarder, der dette er aktuelt. Lydeffekt samsvar med direktiv 2000/14/EG vedlegg VI og 2005/88/EG, for maskiner i henhold til artikkel 12 i meldte organ er **AVT Reliability, Unit 2 Easter Court, Europa Boulevard, Warrington, Cheshire, WA5 7ZB, GB**.
Støy Tekniske filene holdes av Ray Neilson på Belle gruppen hovedkontor adresse som er angitt ovenfor.

(SF) Me, **Belle Group Sheen UK, Sheen, Nr. Buxton, Derbyshire, SK17 0EU, GB**, todistaa, että jos tuote on kuvattu tämän todistuksen ostetaan valtuutetun Belle jälleenmyyjä ETY:n sisällä, se täyttää seuraavat EY-direktiivihin: 2006/42/EY (tällä direktiivillä korvataan direktiivi 98/37/EY), sähkömagneettinen yhteensopivuutta direktiivin 2004/108/CE (muutettuna 89/336/ETY, 92/31/ETY ja 93/68 ETY), Tuhkaa Sähkö ja Sähköinen Varusteet (WEEE) 2002/96/CE, the matalajännittdirektiivistä 2006/95/CE, SFS-EN ISO 12100-1:2003 Koneeturvallisuus ja niihin liittyvien yhdenmukaistettujen standardien tarvitessa. Melupäästöjä täyttävät direktiivin 2000/14/EY liitteessä VI ja 2005/88/EG, koneiden 12 artiklan mukaisesti ilmoitetun laitoksen on **AVT Reliability, Unit 2 Easter Court, Europa Boulevard, Warrington, Cheshire, WA5 7ZB, GB**.
Noise Tekniset tiedostot hallussa Ray Neilson at Belle pääkonttori osoite, joka on edellä.

(PL) My, **Belle Group Sheen UK, Sheen, Nr. Buxton, Derbyshire, SK17 0EU, Wielka Brytania**, niniejszym poświadczamy, iż produkt opisany w tym świadectwie został zakupiony od autoryzowanej Belle Group w UE i jest zgodny z następującymi dyrektywami UE: 2006/42/EY (Niniejsza dyrektywa zastępuje dyrektywę 98/37/EC), Dyrektywa zgodności elektromagnetycznej 2004/108/CE (z poprawkami wniesionymi przez 89/336/EEC, 92/31/EEC i 93/68 EEC), Utylizacja sprzętu elektrycznego i elektronicznego 2002/96/CE, dyrektywę w sprawie niskich napięć 2006/95/CE, BS EN ISO 12100-1:2003 Bezpieczeństwo maszyn i związane normy harmonizacyjne, tam gdzie to ma zastosowanie. Poziom halasu jest zgodny z Dyrektywą 2000/14/EC Załącznik VI i 2005/88/EG, organizacja zawiadaniama (odnośnie zgodności) to **AVT Reliability, Unit 2 Easter Court, Europa Boulevard, Warrington, Cheshire, WA5 7ZB, Wielka Brytania**.
Hałas techniczne pliki są przechowywane przez Ray Neilsonem na grupy głowy Belle adres Biura zamieszczonego powyżej.

PRODUKTYP.....	TIPO PRODOTTO	PRODUKTYP.....
MODELL	MODELLO	MODELL.....
SERIENNR.....	SERIE N°	SERIE NR.....
HERSTELLUNGSDATU	DATA DI FABBRICAZIONE.....	TILLVERKNINGSDATUM.....
SCHALLLEISTUNGSPEGEL GEMESSEN /	LIVELLO POTENZA SONORA MISURATA /	LJUDSTYRKA UPPMÄTT /
.....(GARANTIERT)(GARANTITA)(GARANTERAD)
GEWICHT.....	PESO	VIKT.....
PRODUKTYP.....	TUOTETYYPI	TYP PRODUKTU.....
MODELL	MALLI	MODEL
SERIE NR.....	VALMISTUSNRO	Nr SERII.....
PRODUKSJONS DATO	VALMISTUSPÄIVÄ	DATAPRODUKCI
ÄLYDKRAFTIVÄ MÅLT /	ÄNENVOIMAKUUDEN TASO MITATTU /	POZIOM MOCY DŹWIĘKU ZMIERZONY /
.....(GARANTERT)(TAATTU)(GWARANTOWANY)
VEKT.....	MASSA	WAGA



Unterzeichnet von:
Firmato da:
Underteknat:
Signatur:
Allekirjoitus:
Podpisal:
Ray Neilson

Generalidirektor - Im auftrag von BELLE GROUP (SHEEN) UK.
Amministratore Delegato - Per conto di BELLE GROUP (SHEEN) UK.
V.D. - På vägnar av BELLE GROUP (SHEEN) UK.
Managing Director - På vegne av SOCIETE BELLE GROUP (SHEEN) UK.
Toimitusjohtaja - BELLE GROUP (SHEEN) UK: n puolesta.
Dyrektor Zarządzający - w imieniu BELLE GROUP (SHEEN) UK

Erklärungsart - Sheen, Nr. Buxton, Derbyshire, SK17 0EU, UK	Erklärungsdatum - 2017.....
Luogo de dichiarazione - Sheen, Nr. Buxton, Derbyshire, SK17 0EU, UK	Data de dichiarazione - 2017.....
Plats av Förklaring - Sheen, Nr. Buxton, Derbyshire, SK17 0EU, UK	Datum av Förklaring - 2017.....
Sted av Erklæring - Sheen, Nr. Buxton, Derbyshire, SK17 0EU, UK	Dato av Erklæring - 2017.....
Julistuksen paikka - Sheen, Nr. Buxton, Derbyshire, SK17 0EU, UK	Juulistuksen päivämäärä - 2017.....
Miejsce deklaracji - Sheen, Nr. Buxton, Derbyshire, SK17 0EU, UK	Data deklaracji - 2017.....

**ES PROHLÁŠENÍ O SHODĚ / DECLARATIE DE CONFORMITATE CE /
EU MEGFELELŐSÉGI NYILATKOZAT / EC UYUM BİLDİRGESİ / EC İZJAVA O USKLAĐENOSTI /
PREHLÁŠENIE O ZHODE**



My, **Belle Group Sheen UK, Sheen, Nr. Buxton, Derbyshire, SK17 0EU, Velké Británie**, tpovrzujeme, že v prípade výrobkov uvedených v tomto osvedčení je kúpou od autorizovaného dealera Belle skupiny v rámci EHS, že spĺňa nasledujúci smerníc EHS: 2006/42/CE (tato smernice nahradzuje smernici 98/37/ES) (Elektromagnetická kompatibilita Smernice 2004/108/CE v znení 89/336/EEC, 92/31/EEC & 93/68 EHS). Odpadných elektrických a elektronických zariadeniach (OEEZ), 2002/96/CE, nízkonapäťové smernice 2006/95/CE, BS EN ISO 12100-1:2003 Bezpečnosť strojích zariadení a súvisiacej harmonizované normy, popípadá. Hlukových emisii v súlade so smernici 2000/14/ES príloha VI a 2005/88/ES, so stroje podľa článku 12 oznámený subjekt **AVT Reliability, Unit 2 Easter Court, Europa Boulevard, Warrington, Cheshire, WA5 7ZB, Velká Británie**.
Hluk Technické soubory jsou drženy Ray Neilson v sídle skupiny Belle Office adresu, která je uvedeno výše.



Noi, **Belle Group Sheen UK, Sheen, Nr. Buxton, Derbyshire, SK17 0EU, GB**, certific prin prezenta că în cazul în care produsul descris în cadrul acestui certificat este cumparat de la un distribuitor autorizat Belle Group în cadrul CEE, este conformă cu următoarele directive CEE: 2006/42/CE (prezenta directivă înlocuiește Directiva 98/37/CE), de compatibilitate electromagnetică a Directivei 2004/108/CE (astfel cum a fost modificată prin 89/336/CEE, 92/31/CEE și 93/68/CEE), Deșeurile electrice și electronice (DEEE) 2002/96/CE, tensiune scundă a Directivei 2006/95/CE, BS EN ISO 12100-1:2003 Securitatea mașinilor și asociate standardele armonizate, altele unde este cazul. A emișilor de zgomot în conformitate cu Directiva 2000/14/CE anexa VI & 2005/88/CE, pentru mașini în temeiul articolului 12 organismul notificat este **AVT Reliability, Unit 2 Easter Court, Europa Boulevard, Warrington, Cheshire, WA5 7ZB, GB**.
Fișierele de zgomot tehnice sunt deținute de către Ray Neilson la adresa șefului de grup Belle Oficial pentru care este menționat mai sus.



Mi, a **Belle Group Sheen UK, Sheen, Nr. Buxton, Derbyshire, SK17 0EU, Egyesült Királyság** ezúton igazolom, hogy ha a termék leírása belüli ezt a bizonyítványt vásárolt engedélyezett Belle Group kereskedő az EGK, az megfelel az alábbi EEC irányelveknek: 2006/42/CE (ez az irányelv felváltja a 98/37/EK irányelv) , elektromágneses kompatibilitási irányelv 2004/108/CE (módosított 89/336/EGK, 92/31/EGK és 93/68 EGK). A hulladéki elektromos és elektronikus berendezések (WEEE) 2002/96/CE, kisfeszültségű irányelv 2006/95/CE, BS EN ISO 12100-1:2003 Gépek biztonságára és a kapcsolódó harmonizált szabványok, adott esetben. Zajkibocsátás megfelel a 2000/14/EK irányelv VI és 2005/88/EK gépéhez a 12. cikk alapján a bejelentett szervezet: **AVT Reliability, Unit 2 Easter Court, Europa Boulevard, Warrington, Cheshire, WA5 7ZB, Egyesült Királyság**.
Zaj mûszaki fájlokak birtokában Ray Neilson, a Belle-csoport központi iroda címet, amely a fent.



Mi, **Belle Group Sheen UK, Sheen, Nr. Buxton, Derbyshire, SK17 0EU, GB**, ovime potvrđujem da ako proizvod opisan unutar ovog certifikata je kupio od Belle Group ovlaštenog distributera unutar EEZ, ona odgovara sljedećim EEC smjernica: 2006/42/CE (Ova direktiva zamjenjuje direktiva 98/37/EC yrine) , Elektromagnetska kompatibilnost Direktiva 2004/108/CE (kako je izmijenjeno 89/336/EEC, 92/31/EEC i 93/68 EEC). Otpad električne i elektroničke opreme (WEEE) 2002/96/CE, niskonaponske direktive 2006/95/CE, BS EN ISO 12100-1:2003 Sigurnost strojeva i pridružene usklađene standarde, gdje je primjenjivo. Emisija buke u skladu s direktivom 2000/14/EC Anexa VI i 2005/88/EC, za strojeve iz članka 12. obavještenji tijeli **AVT Reliability, Unit 2 Easter Court, Europa Boulevard, Warrington, Cheshire, WA5 7ZB, GB**.
Buka Tehnički datoteke drže Ray Neilson na Glavnom Belle grupe Office adresu koja je navedeno gore.



Biz, **Belle Group Sheen UK, Sheen, Nr. Buxton, Derbyshire, SK17 0EU, GB**, Belle Group Eđer ürün bu sertifikayı içinde açıklanan burada da tasdik AET içinde yetkili Belle Grup diler satın oldugundan, aşağıdaki AET direktiflerine uyumludur: 2006/42/CE (Bu yönerge yönergesi 98/37/EC yrine) , Elektromanyetik Uyumluluk Yönetmeliği 2004/108/CE (as 89/336/EEC, 92/31/EEC ve 93/68 AET tarafından) değiştirilmiştir. Atık Elektrikli ve Elektronik Ekipman (WEEE) 2002/96/CE, alçak gerilim direktifi 2006/95/CE, BS EN ISO 12100-1:2003 Makine Güvenliği ve ilgili uyumlaştırmış standartlar, uygulanabilir. Onaylanmış kuruluş, madde 12 altında makineleri için, gürtütlü emisyonları direktifleri 2000/14/EC Ek VI ve 2005/88/EC ile uyumlu **AVT Reliability, Unit 2 Easter Court, Europa Boulevard, Warrington, Cheshire, WA5 7ZB, GB**.
Gürtütlü Teknik dosyaları yukarıda belirtildiği Belle grup Merkez adresinde Ray Neilson tarafından tutulur.



Vi, **Belle Group Sheen UK, Sheen, Nr. Buxton, Derbyshire, SK17 0EU, GB**, potvrđujem, že v prípade výrobkov uvedených v tomto osvedčení je kúpou od autorizovaného dealera Belle skupiny v rámci EHS, že spĺňa nasledujúce smernice EHS: 2006/42/CE (tato smernica nahradza smernicu 98/37/ES) (Elektromagnetická kompatibilita Smernice 2004/108/CE v znení 89/336/EEC, 92/31/EEC & 93/68 EHS). Odpadových elektrických a elektronických zariadeniach (OEEZ), 2002/96/CE, nízkonapäťové smernice 2006/95/CE, BS EN ISO 12100-1:2003 Bezpečnosť strojových zariadení a súvisiace harmonizované normy, prípadne. Hlukových emisii v súlade so smernici 2000/14/ES príloha VI a 2005/88/ES, na stroje podľa článku 12 notifikovaný orgán **AVT Reliability, Unit 2 Easter Court, Europa Boulevard, Warrington, Cheshire, WA5 7ZB, GB**.
Hluk Technické súbory sú držané Ray Neilson v sídle skupiny Belle Office adresu, ktorá je uvedené vyššie.

TYP PRODUKU	TIPUL PRODUSULUI	A TERMÉK TÍPUSA
MODEL	MODEL	MODELL
SERI ČÍSL	SERIA	GYÁRI SZÁM
DATUM VÝROBY	DATA FABRICARII	GYÁRTÁSI IDŐ
NAMÉŘENÁ HL. HLUKU /(GARANTOVANÁ)	NIVEL DE ZGOMOT MASURAT /(GARANTAT)	A MÉRT HANGERŐSZINT /(GARANTÁLT)
HMOTNOST	GREUTATEA	SÚLY
TIP PROIZVODA	ÜRÜN TIPI	TYP PRODUKTU
MODEL	MODEL	MODEL
SERJSKI Br.	SERI NUMARASI	SÉRIOVÉ ČÍSLO
DATUM PROIZVODNJE	ÛRETIM TARIHI	DÁTUM VÝROBY
NIVO SNAGE ZVUKA IZMJEREN /(GARANTIRANO)	SES SEVIYE ÖLÇÜMÜ /(GARANTI EDILEN)	NAMERANÁ HLADINA HLUKU /(GARANTOVANÁ)
TEŽINA	AĞIRLIĞI	HMOTNOST



Podpešal:
Semnat de:
Aláfás:
Potpisao:
Imzalayan:
Podpisal:

Ray Neilson

Generální ředitel – jménem BELLE GROUP (SHEEN) UK
Director General - in numele BELLE GROUP (SHEEN), UK
Ûgvezetõ igazgatõ - A BELLE GROUP (SHEEN) UK nevõben
Izvršni Direktor – U ime BELLE GROUP (SHEEN) UK
Yönetici - BELLE GROUP (SHEEN) UK adına.
Generálny riaditeľ – menom BELLE GROUP (SHEEN) UK

Místo Deklarace - Sheen, Nr. Buxton, Derbyshire, SK17 0EU, UK	Datum Deklarace - 2017
Locul declaratiei - Sheen, Nr. Buxton, Derbyshire, SK17 0EU, UK	Data declaratiei - 2017
Kiállítás Helye - Sheen, Nr. Buxton, Derbyshire, SK17 0EU, UK	Kiállítás Ideje - 2017
Mjesto izjave o usklađenosti - Sheen, Nr. Buxton, Derbyshire, SK17 0EU, UK	Datum izjave o usklađenosti - 2017
Declaration Yeri - Sheen, Nr. Buxton, Derbyshire, SK17 0EU, UK	Declaration Tarihi - 2017
Miesto Deklarácie - Sheen, Nr. Buxton, Derbyshire, SK17 0EU, UK	Dátum Deklarácie - 2017



How To Use This Manual

This manual has been written to help you operate and service the 'RPX' safely. This manual is intended for dealers and operators of the 'RPX'.

Foreword

The '**Machine Description**' section helps you to familiarise yourself with the machine's layout and controls.

The '**Environment**' section gives instructions on how to handle the recycling of discarded apparatus in an environmentally friendly way.

The '**General Safety**' and '**Health and Safety**' sections explain how to use the machine to ensure your safety and the safety of the general public.

The '**Start and Stop Procedure**' helps you with starting and stopping the machine.

The '**Trouble Shooting Guide**' helps you if you have a problem with your machine.

The '**Service & Maintenance**' section is to help you with the general maintenance and servicing of your machine.

The '**Warranty**' Section details the nature of the warranty cover and the claims procedure.

The '**Declaration of conformity**' section shows the standards that the machine has been built to.

Directives with regard to the notations.

Text in this manual to which special attention must be paid are shown in the following way:



CAUTION

The product can be at risk. The machine or yourself can be damaged or injured if procedures are not carried out in the correct way.



WARNING

The life of the operator can be at risk.



WARNING



WARNING

*Before you operate or carry out any maintenance on this machine **YOU MUST READ** and **STUDY** this manual.*

KNOW how to safely use the unit's controls and what you must do for safe maintenance. (NB Be sure that you know how to switch the machine off before you switch on, in case you get into difficulty.)

ALWAYS wear or use the proper safety items required for your personal protection. If you have **ANY QUESTIONS** about the safe use or maintenance of this unit, ASK YOUR SUPERVISOR OR CONTACT: **Altrad Belle (UK): +44 (0)1298 84606**



Contents

How To Use This Manual	6
Warning	6
Machine Description	7
Environment	7
Decals	8 - 9
Technical Data	10
Reasons For Compaction	10
General Safety	11
Health and Safety	11
Pre-Start Checks	12
Start and Stop Procedure	12 - 13
Operating Instructions	14
Service & Maintenance	15 - 16
Trouble Shooting Guide	17
Warranty	18
Declaration of Conformity	2

Altrad Belle reserves the right to change machine specification without prior notice or obligation.

Machine Description



1. Throttle lever.
2. Electric Start (Diesel Electric Start only).
4. Lifting Point.
5. Handle Release Catch.
6. Forward / Reverse Control Handle.
7. Steering Handle.
8. Belt Guard.
9. Foot Rest.
10. Handle Adjustment Bolt.
11. Integrated Wheel Kit.
12. Towing Eye
13. Recoil Start Handle (Petrol only)
14. Emergency Stop (Petrol only)
15. Stop Button (Diesel only)
16. Hourmeter (optional)

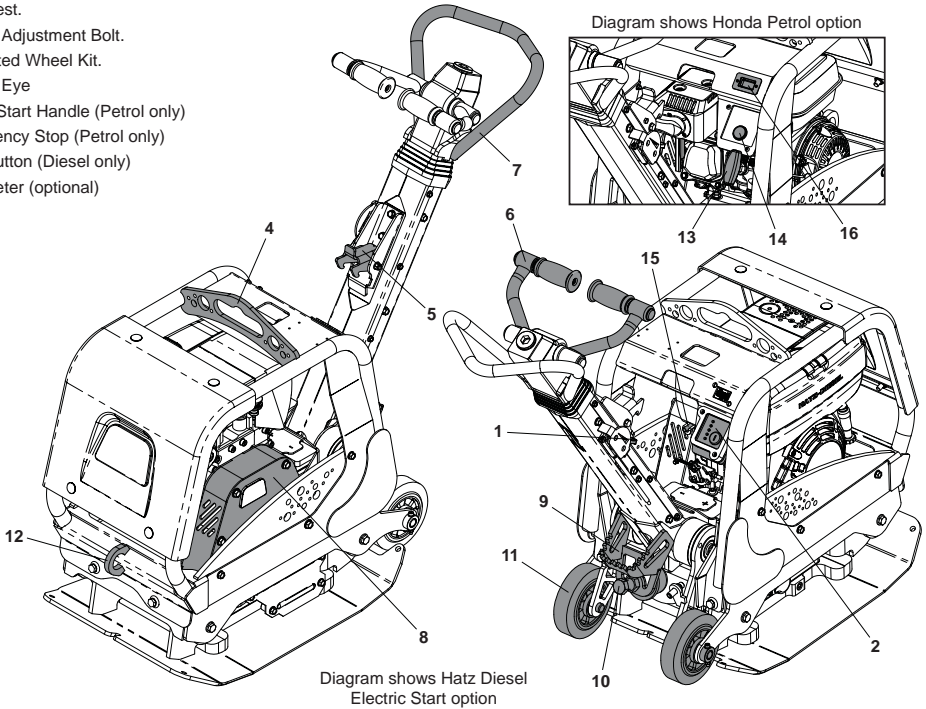

Environment



Safe Disposal.



Instructions for the protection of the environment. The machine contains valuable materials. Take the discarded apparatus and accessories to the relevant recycling facilities.

Component	Material
Handle	Steel
Front Cover	Hdpe
Main Frame	Steel
Baseplate	Steel
Hand Grips	Polyurethane Foam
Engine	Aluminium
Flexible Mounts	Steel And Rubber
Various Parts	Steel And Aluminium

- A. Forward / Reverse & No Lift Decal
- B. Throttle Decal
- C. Lifting Point Decal
- D. Hot Parts Decal
- E. No Lift Decal
- F. Diesel Engine Stop Decal
- G. Safety Decal
- H. Noise Decal
- J. Battery Charge Decal
- K. Warning Decal
- L. Petrol Engine Stop Decal

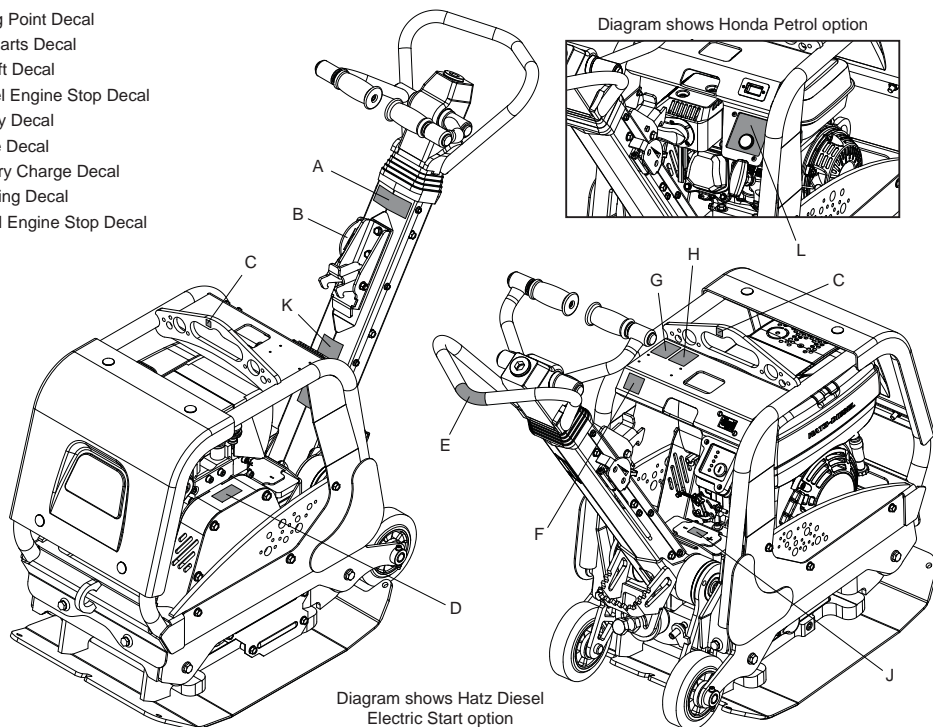

A. Forward / Reverse & No Lift Decal

Indicates how to move the compactor forwards and backwards and highlights that the Forward / Reverse Control Handle and Steering Handle should not be used as Lifting Points.

B. Throttle Decal



**Fast Engine
Speed Position**

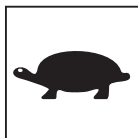

**Slow Engine
Speed Position**

C. Lifting Point Decal

Identifies the correct lifting point on the compactor.

D. Hot Parts Decal

This area may get hot - **DO NOT** touch.

E. No Lift Decal

This area should not be used as a Lifting Point.

F. Diesel Engine Stop Decal

Identifies the position of the Engine Stop Button.

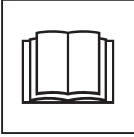
G. Safety Decal

**Please Read
Operators
Manual**



**Wear Protective
Footwear**



**Wear Ear
Protection**



**Wear Eye
Protection**

H. Noise Decal

Identifies the Noise Level of the machine

J. Battery Charge Decal (Diesel Electric Start model only)

Read the Operators Manual for information on charging the Li-Ion battery.

K. Warning Decal

- A. **DO NOT** run the engine whilst the machine is being manouvered on its wheels.
- B. **DO NOT** operate the machine in reverse on an incline.
- C. **DO NOT** operate in reverse up to an enclosed or restrictive space.

L. Petrol Engine Stop Decal

Press and hold the Stop Button for 5 seconds to stop the engine.

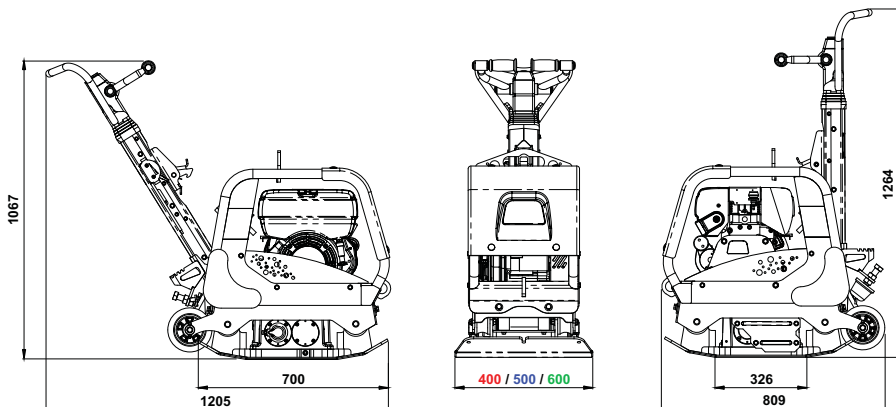

Model	RPX 35/40			RPX 35/50			RPX 35/60		
Engine	Honda GX200	Hatz 1B20	Hatz 1B20 Electric Start	Honda GX200	Hatz 1B20	Hatz 1B20 Electric Start	Honda GX200	Hatz 1B20	Hatz 1B20 Electric Start
Engine Power (Hp / kW)	5.5/4.0	4.2/3.1	4.2/3.1	5.5/4.0	4.2/3.1	4.2/3.1	5.5/4.0	4.2/3.1	4.2/3.1
Engine RPM	3000	3000	3000	3000	3000	3000	3000	3000	3000
Weight (Kg)	176	187	189	1800	191	194	185	196	207
Static Pressure (kg/m ²)	1351	1436	1449	1104	1172	1190	944	1000	1057
Centrifugal Force (kN)	35	35	35	35	35	35	35	35	35
Frequency (Hz)	81	81	81	81	81	81	81	81	81
Max Gradient (°)	20	20	20	20	20	20	20	20	20
Maximum Travel Speed (m/min)	27	27	27	26	26	26	25	25	25
*3-Axis Vibration (m/sec ²)	3.1	2.4	2.4	3.1	2.4	2.4	3.1	2.4	2.4
Noise Level (dB(A))	108	108	108	108	108	108	108	108	108

* Minimum level to EN500 Part 4

Reasons For Compaction

Soil, which has been disturbed or new infill, subbase and blacktop, will have small voids or air pockets which, if not compacted, will lead to one or more problems occurring.

1. As traffic crosses the surface of an uncompacted area, the material is compressed. This leads to subsidence of the top surface as the material fills the voids.
2. A similar situation occurs with static loads on uncompacted ground. The load (e.g. a building) will sink.
3. Materials with voids are more susceptible to water seepage, leading to erosion. Water ingress may also cause the soil to expand during freezing temperatures and contract during dry spells. Expansion and contraction is a major cause of damage to building foundations and normally leads to the structure requiring underpinning.

Compaction increases the density of the material and therefore increases its load bearing capacity. Reduces air voids and therefore reduces the risk of subsidence, expansion and contraction, due to ingress of water.

General Safety



For your own personal protection and for the safety of those around you, please read and ensure you fully understand the following safety information. It is the responsibility of the operator to ensure that he/she fully understands how to operate this equipment safely. If you are unsure about the safe and correct use of the 'RPX', consult your supervisor or Altrad Belle.



CAUTION

Improper maintenance can be hazardous. Read and Understand this section before you perform any maintenance, service or repairs.

- This equipment is heavy and must not be lifted single-handedly, either **GET HELP** or use suitable lifting equipment.
- Cordon off the work area and keep members of the public and unauthorised personnel at a safe distance.
- Personal Protective Equipment (PPE) must be worn by the operator whenever this equipment is being used (see Health & Safety).
- Make sure you know how to safely switch this machine **OFF** before you switch it **ON** in case you get into difficulty.
- Always switch **OFF** the engine before transporting, moving it around the site or servicing it.
- During use the engine becomes very hot, allow the engine to cool before touching it. Never leave the engine running and unattended.
- Never remove or tamper with any guards fitted, they are there for your protection. Always check guards for condition and security, if any are damaged or missing, **DO NOT USE THE COMPACTOR** until the guard has been replaced or repaired.
- **DO NOT** operate the Compactor when you are ill, feeling tired, or when under the influence of alcohol or drugs.



CAUTION

Fuel is flammable. It may cause injury and property damage. Shut down the engine, extinguish all open flames and do not smoke while filling the fuel tank. Always wipe up any spilled fuel.

Fuel Safety.

- Before refuelling, switch off the engine and allow it to cool.
- When refuelling, **DO NOT** smoke or allow naked flames in the area.
- Spilt fuel must be made safe immediately, using sand. If fuel is spilt on your clothes, change them.
- Store fuel in an approved, purpose made container away from heat and ignition sources.

Health & Safety



Vibration

Some vibration from the compaction operation is transmitted through the handle to the operator's hands. The Altrad Belle RPX range has been specifically designed to reduce hand/arm vibration levels. Refer to specifications & technical data for vibration levels and usage times (recommended maximum daily exposure time). **DO NOT** exceed the maximum usage times.

PPE (Personal Protective Equipment)

Suitable PPE must be worn when using this equipment i.e. Safety Goggles, Gloves, Ear Defenders, Dust Mask and Steel Toe capped footwear. Wear clothing suitable for the work you are doing. Tie back long hair and remove any jewellery which may catch in the equipment's moving parts. Always protect skin from contact with concrete.

Dust

The compacting process will occasionally produce dust, which may be hazardous to your health. Always wear a mask that is suited to the type of dust being produced.

Fuel

DO NOT ingest fuel or inhale fuel vapours and avoid contact with your skin. Wash fuel splashes immediately. If you get fuel in your eyes, irrigate with copious amounts of water and seek medical attention as soon as possible.

Exhaust Fumes

DO NOT operate the compactor indoors or in a confined space, make sure the work area is adequately ventilated.



WARNING

The exhaust fumes produced by this equipment are highly toxic and can kill!



Pre-Start Checks

Pre start-up inspection

The following Pre-start-up inspection must be performed before the start of each work session or after every four hours of use, whichever is first. Please refer to the service section for detailed guidance. If any fault is discovered, the compactor must not be used until the fault is rectified.

1. Thoroughly inspect the compactor for signs of damage. Check components are present and secure. Pay special attention to the belt guard.
2. Check the engine oil and hydraulic oil level and top up as necessary.
3. Check the engine fuel level and top up as necessary.
4. Check for fuel, oil and hydraulic leaks.



Start And Stop Procedure

Honda GX200 Petrol Engine

Stopping the Engine

1. To stop the engine, set the throttle control to idle (See Fig. 1), then press and hold the red stop button for 5 seconds until the engine stops (See Fig. 2).
- Turn the fuel **OFF**

Starting the Engine

1. Open the fuel tap by moving the fuel **ON / OFF** lever fully to the right.
2. If starting the engine from cold, set the choke **ON** by moving the choke lever fully to the left. If restarting a warm engine, the choke is usually not required, however, if the engine has cooled to a degree, partial choke may be required.
3. Set the throttle to the idle position by moving the throttle lever fully to the right.
4. Taking a firm hold of the frame with one hand, grasp the recoil starter handle with the other. Pull the recoil starter until engine resistance is felt, then let starter return.
5. Taking care not to pull the starter's rope fully out, pull the starter handle briskly.
6. Repeat until the engine fires.
7. Once the engine fires gradually set the choke lever to the **OFF** position by moving it to the right.
8. If the engine fails to fire after several attempts, follow the Troubleshooting Guide.

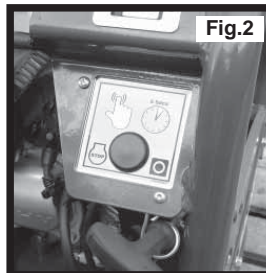
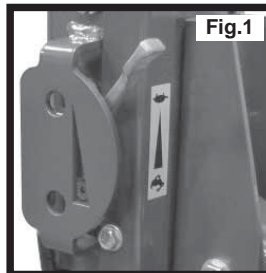

Hatz 1B20 Diesel Engine

Stopping the Engine

1. To stop the engine, set the throttle control to idle (See Fig. 1), then press and hold the red stop button until the engine stops (See Fig. 2).

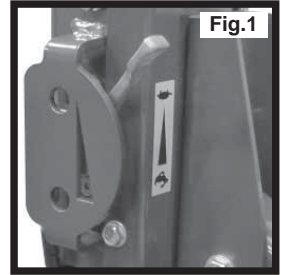

Starting the Engine

1. Turn **ON** the fuel by moving the fuel **ON/OFF** lever fully to the right.
2. Set the engine speed control to start.
3. Taking a firm hold of the control handle with one hand, grasp the recoil starter handle with the other. Pull the handle until engine resistance is felt, then let the starter return.
4. Taking care not to pull the starter's rope fully out, pull the starter handle briskly with both hands.
5. Repeat this procedure until the engine fires.
6. If the engine fails to start after several attempts, Follow the troubleshooting guide.

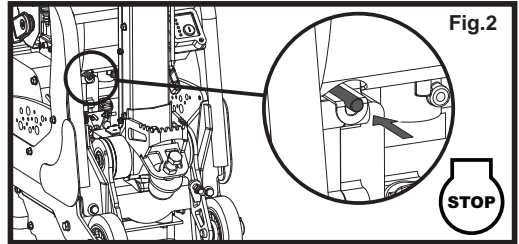

Hatz 1B20 Diesel Engine (Electric Start)

Stopping the Engine

1. To stop the engine, set the throttle control to idle (See Fig. 1), then press and hold the red stop button until the engine stops (See Fig. 2).
2. Turn the key to **position '0'** and remove it. All the indicator lights must go out.
NOTE:- Failure to return the starter key to **position '0'** may result in the battery being totally discharged.

Starting the Engine

1. Insert the key and turn it to **position 'I'** (The battery charge light and oil pressure warning light will light up)
2. Turn start key to **position 'II'**
3. Release the key as soon as the engine runs. The starting key must spring back to **position 'I'** and remain there during engine operation. The battery charge light and oil pressure warning light must go out immediately after starting. Indicator light '1' lights up to show that the engine is running.
4. If anything seems to be incorrect, stop the engine immediately and rectify the fault. (See the Troubleshooting Guide)

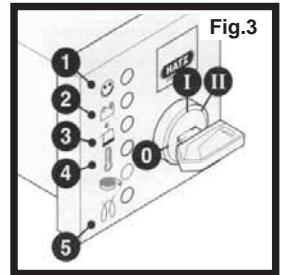

CAUTION

Never operate the electric starter when the engine is running or coasting to a standstill. There is a risk of broken starter pinion or ring gear teeth. Never stop the engine by moving the decompression lever. During breaks in work or at the end of the working period, keep the starting handle and starting key in a safe place, out of reach of unauthorised persons.

5. Always turn the start key back to **position '0'** before re-starting the engine. The repeat lock prevents the starter motor from engaging and possibly being damaged whilst the engine is still running.

- **Take the compactor to where it is required.**
Where it is necessary to use lifting equipment to position the compactor, make sure the lifting equipment has a WLL (Working Load Limit) suitable for the compactors weight (see Technical Data section or the machine serial plate). Attach suitable chains or slings **ONLY** to the lifting point (*Item 4 of the Machine Description*) on the top of the compactor.
- **Moving the compactor using the integrated wheel kit**
 - Use the Fixed Steering Handle (*Item 7*) to tilt the machine backwards onto the integrated wheels (*Item 11*).
 - Manoeuvre only on smooth, flat, firm surfaces. These wheels are not designed for soft, uneven surfaces.
 - To lower the machine off it's wheels - stand on the foot rest (*Item 9*) and allow the machine to lower using your body weight as a counter balance.



CAUTION NEVER leave the engine running whilst the machine is being manoeuvred on its wheels.

- **Having carried out the checks listed in the 'Pre Start' section, you may start the engine.**
The Altrad Belle 'RPX' range of compactors are fitted with a centrifugal clutch, this allows the engine to run at idle without driving the gearbox.

As the engine speed is increased the clutch will engage and will drive the gearbox. For correct operation, the engine speed should be set to maximum.

- **Set the throttle to maximum and use the control handle for direction and to steer or turn the compactor.**
The control handle has been designed so that when it is being used in reverse and the operator lets go for any reason, the handle automatically moves into forward mode. This is a significant safety feature of the machine.
During normal operation you should not have to push the compactor but allow it to travel at its own pace.
The speed of travel will be determined by the condition of the surface being compacted.
Caution must be used when operating the compactor in reverse. Ensure that there are no obstructions or trip hazards when operating in reverse.
If the surface to be compacted is on a slope, great care must be taken when controlling the compactor's direction of travel. If necessary, use a suitable rope attached to the compactor at a low point on the chassis, to allow a helper to take part of the compactor's weight. Work up and down a slope not across.
- **Work the compactor over the surface in an organised pattern until the required compaction has been achieved.**
Where there are a number of different layers to be compacted on top of each other, compact each layer individually.
- To stop the compactor vibrating, set the throttle to idle. To stop the engine refer to the relevant Start / Stop procedure.



CAUTION DO NOT operate the machine in reverse on an incline.
DO NOT operate in reverse up to an enclosed or restrictive space.



CAUTION DO NOT use on boggy, waterlogged ground as the compactor will sink and cause excessive loading to the engine and drive system.

The Altrad Belle 'RPX' range of Reversible Plate Compactors are designed to give many years of trouble free operation. It is, however, important that the simple regular maintenance listed in this section is carried out. It is recommended that an approved Altrad Belle dealer carries out all major maintenance and repairs. Always use genuine Altrad Belle replacement parts, the use of spurious parts may void your warranty.

Before any maintenance is carried out on the machine, switch off the engine. If working on a diesel engine, make sure that the stop switch is in the stop position.

Always set the compactor on level ground to ensure any fluid levels will be correctly read. Only use recommended oils (see chart on following page).

Running In Period

When the compactor is first used from new, the engine oil must be changed after the initial running in period (see engine manufacturer's manual for full detail). The belt tension should be checked after 4 hours use.

Drive Belt

Remove the belt guard then check the belt tension by placing light finger pressure on the top of the belt, as near central between the engine drive and gearbox pulley. The belt should deflect by approx. 10 to 15mm. If the belt tension requires adjustment, loosen the setscrew on the Belt Tensioning device and slide to the right. Once set, retighten the setscrew and check belt tension a second time. Finally, replace the belt guard ensuring it is correctly and securely fitted.

Routine Maintenance		Every 8 Hours	First Month / 50 Hours	150 Hours	250 Hours	500 Hours
Engine Oil	Check Level	✓				
	Change		✓		✓	
Air Filter	Check Condition / Clean		✓			
	Replace when necessary / Every 12 months					
Spark Plug	Change					✓
Drive Belt	Tension		✓		✓	

Oil / Fuel Type & Quantity - Spark Plug Type

	Oil Type	Quantity (Litre)	Fuel Type	Capacity (Litre)	Spark Plug Type	Electrode Gap (mm)
Honda GX200 Petrol	S.A.E. 10W 30	0.6	Unleaded Petrol	3.1	BPR6ES (NGK)	0.7 - 0.8mm
Hatz 1B20 Diesel	S.A.E. 10W 30	0.9	Diesel (BS2869)	Refer to Manual	N/A	N/A

Oil Type & Quantity

Component	Oil Type	Honda GX200 (Litres)	Hatz 1B20 (Litres)
Gearbox	S.A.E. 10W 40	0.72	0.72
Hydraulic Control	Shell Tellus 32	0.2	0.2
	Fuchs Renolin MR520	0.2	0.2

Li-Ion Battery - Charging (Hatz 1B20 Diesel Electric model only)

- Use **ONLY** specific Li-ion battery chargers
- **DO NOT** charge the battery with charging voltage of over 15.0V
- **DO NOT** use any charger with automatic desulphation function
- When possible, remove the battery from the vehicle before charging
- Charging voltage should be 14.0 – 15.0V for both vehicle and battery charger. Lower voltage will result in insufficient charge. Higher voltage will cause damage to the battery
- Respect the standard & maximum charge current indicated on the battery labels
- Avoid draining the battery to less than 8V. If the voltage drops to below 8V, refer to the charger manual
- If the battery becomes hot to the touch, stop charging and allow the battery to cool before resuming
- After charging, wait 1 to 2 hours before checking the voltage. If the voltage is less than 12.8V, additional charging is necessary

**CAUTION**

WHILST RUNNING THIS MACHINE DURING THIS PROCEDURE, IT IS ADVISABLE TO PUT THE MACHINE ONTO A RUBBER MAT OR EQUIVALENT TO ABSORB SOME OF THE VIBRATION.

Bleeding the Hydraulic System

1. Ensure the machine is in a stationary position, and situated on level ground.
2. Remove the filler cap, and fill the control pump head with oil. Stop once you have reached the maximum level indicator, which is within the head.
3. Slowly pump the control handle from the 'Forward Motion' position, to the 'Reverse Motion' position, until the oil level drops.
4. Re-fill the control pump head upto the maximum level. Continue to pump the handle until resistance is felt, and the handle locks in the 'Reverse Motion' position.
5. Again, re-fill the control pump head upto the maximum level.
6. Re-fit the Filler Bung, and test the machine.

Assembly of the Control Pump

1. Carefully clean the housing with compressed air on the inside. Check for scratches on sliding bores for O Rings and there are no sharp edges.
2. Press the Bushing in to Housing.
3. Lubricate the Lip Seal with Hydraulic Oil and slip it on the Rack (open side away from the rack).
4. Lubricate the Rack with Hydraulic Oil and slide it into the Housing until the Lip Seal is in the groove, making sure the teeth are in the right position. When the Lip Seal is in the Groove this represents forward motion.

**CAUTION**

In reverse motion the Control Handles run parallel with the Housing in the direction of the operator.

5. After lubricating the Pinion (without O Rings), insert it into the Housing and Rack. Check the movement of the Rack from Forward to Reverse. (See **CAUTION**).
6. Take the Pinion out and fit the two O Rings, making sure they are not damaged.
7. Lubricate the Pinion and O Rings with hydraulic oil and carefully insert in to the Housing. Make sure the Rack is in the right position and this is easiest when in reverse motion.
8. Fit the Shim and Retaining Ring. It may be necessary to push the Pinion from the opposite side to get them assembled.
9. Place the Housing on the filler side and fit the O Rings to the bottom face. **LOCTITE seal 518** is recommended.
10. Assemble the Hydraulic Connector and Dowty Washer using **LOCTITE 243**.
11. Assemble the Bracket and fix with 4 screws and washers using **LOCTITE 243**.
12. Loosely fit the Plug Screw and Washer **DO NOT TIGHTEN**.

Trouble Shooting Guide



Problem	Cause	Remedy
Engine will not start.	No fuel.	Open fuel tap. Fill fuel tank.
	Engine switched off.	Switch engine on.
	Spark plug fouled.	Clean and reset plug gap.
	Engine cold.	Close choke.
	Engine Flooded.	Honda, open choke, fully open throttle, pull recoil starter until engine fires. Hatz, move speed control to stop, pull recoil starter 5 times then repeat start procedure.
Engine still will not start.	Major Fault.	Contact Agent or Altrad Belle.
Unit will not move.	Engine speed too slow.	Set engine speed control to fast.
	Drive belt tension loose.	Adjust belt tension
	Air filter blocked.	Clean or renew air filter.
	Worn or Damaged Clutch.	Repair or Replace as necessary.
	Drive failure.	Contact Agent or Altrad Belle.
	Gearbox failure.	Contact Agent or Altrad Belle.
Forward speed too slow.	Too much oil in hydraulic head.	Reduce oil level.
	Wrong adjustment of control system	Contact Agent or Altrad Belle.
Reverse speed too slow.	Not enough oil in hydraulic head.	Fill and bleed system.
	Air in control system.	Bleed control system.
	Wrong adjustment of control system	Contact Agent or Altrad Belle.
Loss of Hydraulic Oil.	Connectors leaking.	Reseal connectors.
	Defective hydraulic hose.	Replace hose.
	Piston seal in gearbox defective.	Contact Agent or Altrad Belle.
Machine operates erratically.	Shock mounts damaged.	Replace all four mounts.

Your new Altrad Belle 'RPX' reversible plate compactor is warranted to the original purchaser for a period of one-year (12 months) from the original date of purchase.

The Altrad Belle warranty is against defects in design, materials and workmanship.

The following are not covered under the Altrad Belle warranty:

1. Damage caused by abuse, misuse, dropping or other similar damage caused by or as a result of failure to follow assembly, operation or user maintenance instructions.
2. Alterations, additions or repairs carried out by persons other than Altrad Belle or their recognised agents.
3. Transportation or shipment costs to and from Altrad Belle or their recognised agents, for repair or assessment against a warranty claim, on any machine.
4. Materials and/or labour costs to renew, repair or replace components due to fair wear and tear.

The following components are not covered by warranty.

- Drivebelt/s
- Engine Air Filter
- Engine Spark Plug

Altrad Belle and/or their recognised agents, directors, employees or insurers will not be held liable for consequential or other damages, losses or expenses in connection with or by reason of or the inability to use the machine for any purpose.

Warranty Claims

All warranty claims should firstly be directed to Altrad Belle, either by telephone, by Fax, by Email, or in writing.

For warranty claims:

Tel : +44 (0)1298 84606,

Fax : +44 (0)1298 84073,

Email : Warranty@belle-group.co.uk

or Write to:

Altrad Belle Warranty Department,
Sheen, Nr. Buxton
Derbyshire
SK17 0EU
England

Warranty Registration:

In the bid for ALTRAD Belle to become greener and more eco friendly, we have now introduced online Warranty registration. To access the registration page of our website, please use the following address:-

http://www.bellegroup.com/index.php?p=warranty_registration

Alternatively, please scan the adjacent QR Code (Quick Response Code) using your smartphone to access the registration page.

